

TABLE OF CONTENTS

I. EXECUTIVE SUMMARY 3

II. NOTICES AND COMMUNICATIONS..... 6

III. BACKGROUND 6

 A. Regulatory Framework..... 6

 B. NERC Reliability Standards Development Procedure..... 7

 C. History of the PRC-005 Reliability Standard..... 8

 1. PRC-005-1 8

 2. PRC-005-2 9

 3. PRC-005-3 9

 4. PRC-005-2(i), PRC-005-3(i) 10

 5. PRC-005-2(ii) and PRC-005-3(ii) 10

 6. PRC-005-4 11

 7. PRC-005-5 12

 D. Project 2007-17.4 PRC-005 FERC Order No. 803 Directive (PRC-005-6) 14

IV. JUSTIFICATION FOR APPROVAL 16

 A. Revisions to Address the Inclusion of Supervisory Devices..... 17

 1. Revised Definitions for Use in the Proposed Standard 18

 2. Revisions to Tables..... 19

 3. Use of Abbreviation “PSMP” 20

 B. Dispersed Generation Resources Applicability Revisions (Section 4.2) 21

 C. Proposed Implementation Plan..... 23

 1. Proposed PRC-005-6 Implementation Plan..... 23

 2. Retirement of Previous PRC-005 Standards 26

 D. Alternate Proposal to Approve PRC-005-5..... 27

V. ENFORCEABILITY OF THE PROPOSED RELIABILITY STANDARD 27

VI. CONCLUSION..... 29

- Exhibit A** Proposed Reliability Standard PRC-005-6 and Alternative Proposed Standard PRC-005-5
- Exhibit A-1** Proposed Reliability Standard PRC-005-6 (Clean and Redline [PRC-005-6 to PRC-005-4] & [PRC-005-6 to PRC-005-5])
- Exhibit A-2** Alternative Proposed Reliability Standard PRC-005-5 (Clean and Redline [PRC-005-5 to PRC-005-4])
- Exhibit B** Implementation Plans
- Exhibit B-1a** Implementation Plan PRC-005-6
- Exhibit B-1b** Implementation Plan PRC-005-6 Rationale
- Exhibit B-2** Implementation Plan PRC-005-5 (alternative)
- Exhibit C** Order No. 672 Criteria
- Exhibit D** Draft White Paper, *Proposed Revisions to the Applicability of NERC Reliability Standards to Dispersed Generation Resources*
- Exhibit E** Supplementary Reference and FAQ
- Exhibit F** Consideration of Directives
- Exhibit G** Analysis of Violation Risk Factors and Violation Severity Levels
- Exhibit H** NERC Planning Committee System Analysis and Modeling Subcommittee (“SAMS”) and System Protection and Control Subcommittee (“SPCS”), *Considerations for Maintenance and Testing of Autoreclosing Schemes* (Nov. 2012)
- Exhibit I** Summary of Development and Complete Record of Development
- Exhibit J** Standard Drafting Team Rosters

NERC requests that the Commission approve proposed Reliability Standard PRC-005-6 (**Exhibit A-1**) and find that it is just, reasonable, not unduly discriminatory or preferential, and in the public interest.⁵ NERC also requests approval of the retirement of previous Reliability Standard PRC-005 standard versions as detailed in the implementation plan associated with proposed PRC-005-6 (**Exhibit B-1a**). As discussed below, the proposed PRC-005-6 implementation plan is intended to facilitate an orderly and efficient transition from currently-effective PRC-005-2(i) to proposed PRC-005-6 and represents a significant improvement over the previous implementation approach for these standards. To allow for this orderly transition, NERC has filed, simultaneously with this petition, a Motion to Delay Implementation of the approved, but not yet effective versions of the PRC-005 Reliability Standards in Docket Nos. RM14-8-000 (PRC-005-3), RD15-3-000 (PRC-005-3(i)), and RM15-9-000 (PRC-005-4) until after the Commission issues an order or rule regarding proposed PRC-005-6 and the proposed implementation plan.

As proposed Reliability Standard PRC-005-6 reflects the dispersed generation applicability resources revisions approved by the NERC Board of Trustees in PRC-005-5 and is intended to supersede PRC-005-5, the Commission need not independently approve proposed PRC-005-5. Should the Commission decline to approve proposed PRC-005-6 or its associated implementation plan, however, NERC respectfully requests that the Commission approve PRC-005-5 (**Exhibit A-2**) and its associated implementation plan (**Exhibit B-2**). This approval will ensure that the PRC-005 standard continues to be applied appropriately to dispersed generation

⁵ Unless otherwise designated, capitalized terms shall have the meaning set forth in the *Glossary of Terms Used in NERC Reliability Standards* (“NERC Glossary of Terms”), available at http://www.nerc.com/files/Glossary_of_Terms.pdf.

resources while NERC addresses any of the Commission’s concerns regarding proposed PRC-005-6.

As required by Section 39.5(a)⁶ of the Commission’s regulations, this petition presents the technical basis and purpose of the proposed Reliability Standard, a demonstration that the proposed Reliability Standard meets the criteria identified by the Commission in Order No. 672⁷ (**Exhibit C**), and a summary of the standard development history (**Exhibit I**).

I. EXECUTIVE SUMMARY

The PRC-005 Reliability Standard helps ensure that entities have a program for the maintenance of their applicable Protection Systems, Automatic Reclosing, and Sudden Pressure Relaying so that they are kept in working order. The standard has been revised several times since its initial approval in Order No. 693⁸ to incorporate interpretations, clarify applicability, and respond to Commission directives. Following a restructuring of the standard in PRC-005-2, a number of versions have been developed, including currently-effective PRC-005-2(i), Commission-approved but not yet effective versions PRC-005-3, PRC-005-3(i), and PRC-005-4, and pending versions PRC-005-2(ii) and PRC-005-3(ii).

In this petition, NERC proposes additional modifications that improve upon the most recent Commission-approved version, PRC-005-4, in two respects.⁹ First, proposed Reliability Standard PRC-005-6 revises the standard to include supervisory devices and functions associated

⁶ 18 C.F.R. § 39.5(a) (2012).

⁷ The Commission specified in Order No. 672 certain general factors it would consider when assessing whether a particular Reliability Standard is just and reasonable. *See Rules Concerning Certification of the Electric Reliability Organization; and Procedures for the Establishment, Approval, and Enforcement of Electric Reliability Standards*, Order No. 672, FERC Stats. & Regs. ¶ 31,204, at P 262, 321-37, *order on reh’g*, Order No. 672-A, FERC Stats. & Regs. ¶ 31,212 (2006).

⁸ *Mandatory Reliability Standards for the Bulk-Power System*, Order No. 693, FERC Stats. & Regs. ¶ 31,242 (“Order No. 693”), *order on reh’g*, Order No. 693-A, 120 FERC ¶ 61,053 (2007).

⁹ Reliability Standard PRC-005-4 was approved by the Commission in Docket No. RM15-9-000. *See Protection System, Automatic Reclosing, and Sudden Pressure Relaying Maintenance Reliability Standard*, Order No. 813, 152 FERC ¶ 61,199 (2015) (“Order No. 813”).

with applicable autoreclosing relay schemes. Reliability is improved by extending the protections of a strong Protection System Maintenance Program to these devices consistent with Order No. 803.¹⁰

Second, proposed Reliability Standard PRC-005-6 includes a revision to the PRC-005 standard that was included in prior versions of the standard but, as explained further below, was not carried forward to PRC-005-4 due to the timing of the development of that version. Specifically, proposed Reliability Standard PRC-005-6 includes Commission-approved revisions addressing the applicability of PRC-005 to owners of dispersed generation resources.¹¹ As explained in greater detail below, these revisions reflect the determination of the standard drafting team for Project 2014-01 Standards Applicability for Dispersed Generation Resources that while the components of dispersed power generation, such as individual wind or solar units, often do not pose a significant risk to the reliability of the Bulk-Power System when evaluated individually, reliability could be improved by ensuring the equipment utilized to aggregate these individual units to a common point of interconnection with the Bulk-Power System is operated and maintained as required by the PRC-005 Reliability Standard.¹²

Additionally, as there are now multiple versions of the PRC-005 Reliability Standard pending enforcement or Commission approval, the implementation plan for proposed PRC-005-6

¹⁰ Order No. 803 at P 31.

¹¹ See Letter Order, *N. Am. Elec. Reliability Corp.*, 151 FERC ¶ 61,186 (2015) (approving Reliability Standards PRC-005-2(i), PRC-005-3(i), and certain other Reliability Standards containing revisions to address applicability to owners of dispersed generation resources.). As discussed more fully herein, at the same time the Project 2014-01 Standards Applicability for Dispersed Generation Resources standard drafting team was developing PRC-005-2(i) and PRC-005-3(i) to clarify the applicability of the PRC-005 standard to dispersed generation resources, a separate standard drafting team was developing PRC-005-4 to address the inclusion of Sudden Pressure Relaying. After both sets of revisions were approved by their respective ballot pools and the NERC Board of Trustees, the Project 2014-01 standard drafting team initiated revisions to PRC-005-4 to ensure that the PRC-005 standard would be applied consistently to dispersed generation resources going forward.

¹² As described below, these revisions to PRC-005-4 were approved by the NERC Board of Trustees as PRC-005-5. Proposed Reliability Standard PRC-005-6 incorporates these revisions without further modification.

is designed to assist registered entities and the ERO Enterprise in their transition efforts by simplifying and streamlining the implementation approach for all of the newly-applicable systems introduced in the versions of PRC-005 not yet in effect. As discussed below, the proposed implementation plan retains the reasonable, phased-in implementation approach of past plans, which require registered entities to gradually ensure compliance of a percentage of their devices until they reach 100% compliance. However, NERC proposes to replace the patchwork implementation of requirements for the systems introduced by each successive PRC-005 version with an implementation plan that aligns compliance dates for all newly applicable systems.

Aligning the dates by which registered entities must be compliant for all newly applicable systems necessitates a slight delay from the staggered timeframe contemplated by previous PRC-005 implementation plans. However, the proposed approach advances reliability by: (1) allowing entities sufficient time to develop comprehensive Protection System Maintenance Programs to address all new applicable systems, thereby decreasing the number of opportunities for misidentified and missed devices across successive program revisions and across multiple compliance schedules; (2) promoting the efficient use of entity and ERO Enterprise resources by eliminating the need to create and audit multiple, successive revisions to entity Protection System Maintenance Programs; and (3) providing NERC additional time to provide additional education and outreach to industry regarding the implementation of this important Reliability Standard.

II. NOTICES AND COMMUNICATIONS

Notices and communications with respect to this filing may be addressed to the following:¹³

Charles A. Berardesco*
Senior Vice President and General Counsel
Holly A. Hawkins*
Associate General Counsel
Lauren A. Perotti*
Counsel
North American Electric Reliability Corporation
1325 G Street, N.W., Suite 600
Washington, D.C. 20005
(202) 400-3000
(202) 644-8099– facsimile
charles.berardesco@nerc.net
holly.hawkins@nerc.net
lauren.perotti@nerc.net

Howard Gugel
Director of Standards
North American Electric Reliability Corporation
3353 Peachtree Road, N.E.
Suite 600, North Tower
Atlanta, GA 30326
(404) 446-2560
(404) 446-2595 – facsimile
howard.gugel@nerc.net

III. BACKGROUND

A. Regulatory Framework

By enacting the Energy Policy Act of 2005,¹⁴ Congress entrusted the Commission with the duties of approving and enforcing rules to ensure the reliability of the Bulk-Power System, and with the duties of certifying an ERO that would be charged with developing and enforcing mandatory Reliability Standards, subject to Commission approval. Section 215(b)(1)¹⁵ of the FPA states that all users, owners, and operators of the Bulk-Power System in the United States will be subject to Commission-approved Reliability Standards. Section 215(d)(5)¹⁶ of the FPA authorizes the Commission to order the ERO to submit a new or modified Reliability Standard.

¹³ Persons to be included on the Commission’s service list are identified by an asterisk. NERC respectfully requests a waiver of Rule 203 of the Commission’s regulations, 18 C.F.R. § 385.203 (2012), to allow the inclusion of more than two persons on the service list in this proceeding.

¹⁴ 16 U.S.C. § 824o (2012).

¹⁵ *Id.* § 824o(b)(1).

¹⁶ *Id.* § 824o(d)(5).

Section 39.5(a)¹⁷ of the Commission's regulations requires the ERO to file with the Commission for its approval each Reliability Standard that the ERO proposes should become mandatory and enforceable in the United States, and each modification to a Reliability Standard that the ERO proposes should be made effective.

The Commission is vested with the regulatory responsibility to approve Reliability Standards that protect the reliability of the Bulk-Power System and to ensure that Reliability Standards are just, reasonable, not unduly discriminatory or preferential, and in the public interest. Pursuant to Section 215(d)(2) of the FPA¹⁸ and Section 39.5(c)¹⁹ of the Commission's regulations, the Commission will give due weight to the technical expertise of the ERO with respect to the content of a Reliability Standard.

B. NERC Reliability Standards Development Procedure

The proposed Reliability Standard was developed in an open and fair manner and in accordance with the Commission-approved Reliability Standard development process.²⁰ NERC develops Reliability Standards in accordance with Section 300 (Reliability Standards Development) of its Rules of Procedure and the NERC Standard Processes Manual.²¹

In its order certifying NERC as the Commission's ERO, the Commission found that NERC's proposed rules provide for reasonable notice and opportunity for public comment, due process, openness, and a balance of interests in developing Reliability Standards and thus satisfy

¹⁷ 18 C.F.R. § 39.5(a) (2015).

¹⁸ 16 U.S.C. § 824o(d)(2).

¹⁹ 18 C.F.R. § 39.5(c)(1).

²⁰ *Rules Concerning Certification of the Electric Reliability Organization; and Procedures for the Establishment, Approval, and Enforcement of Electric Reliability Standards*, Order No. 672, FERC Stats. & Regs. ¶ 31,204, *order on reh'g*, Order No. 672-A, FERC Stats. & Regs. ¶ 31,212 (2006).

²¹ The NERC Rules of Procedure are available at <http://www.nerc.com/AboutNERC/Pages/Rules-of-Procedure.aspx>. The NERC Standard Processes Manual is available at http://www.nerc.com/comm/SC/Documents/Appendix_3A_StandardsProcessesManual.pdf.

the criteria for approving Reliability Standards.²² The development process is open to any person or entity with a legitimate interest in the reliability of the Bulk-Power System. NERC considers the comments of all stakeholders, and a vote of stakeholders and the NERC Board of Trustees is required to approve a Reliability Standard before the Reliability Standard is submitted to the Commission for approval.

C. History of the PRC-005 Reliability Standard

The PRC-005 Reliability Standard has been revised several times since its initial approval in Order No. 693²³ to incorporate interpretations, clarify applicability, and respond to Commission directives. NERC provides a brief history of the PRC-005 standard below.

1. PRC-005-1

In Order No. 693, the Commission approved initial versions of four protection system maintenance and load-shedding-related maintenance standards: Reliability Standards PRC-005-1, PRC-008-0, PRC-011-0, and PRC-017-0.²⁴ The Commission approved interpretations PRC-005-1a on September 26, 2011²⁵ and PRC-005-1b on February 3, 2012.²⁶ On September 19, 2013, the Commission approved PRC-005-1.1b, which clarified the standard's applicability to protection systems associated with generator interconnection facilities.²⁷

²² 116 FERC ¶ 61,062 at P 250 (2006).

²³ *Mandatory Reliability Standards for the Bulk-Power System*, Order No. 693, FERC Stats. & Regs. ¶ 31,242 (“Order No. 693”), *order on reh'g*, Order No. 693-A, 120 FERC ¶ 61,053 (2007).

²⁴ Order No. 693 at P 1474, 1492, 1514, and 1546.

²⁵ *North American Electric Reliability Corp.*, 136 FERC ¶ 61,208 (2011).

²⁶ *Interpretation of Protection System Reliability Standard*, Order No. 758, 138 FERC ¶ 61,094 (2012) (“Order No. 758”).

²⁷ *Generator Requirements at the Transmission Interface*, Order No. 785, 144 FERC ¶ 61,221 (2013).

2. PRC-005-2

The Commission approved PRC-005-2 on December 19, 2013.²⁸ PRC-005-2 combined four standards that addressed maintenance and testing of protection and control systems (PRC-005-1b, PRC-008-0, PRC-011-0, and PRC-017-0) into one comprehensive Reliability Standard. Consistent with certain directives from Order No. 693, PRC-005-2 included specific minimum maintenance activities and maximum time intervals for testing Protection System components. PRC-005-2 also established criteria for developing and maintaining a performance-based maintenance program.

The PRC-005-2 implementation plan required entities to develop a PRC-005-2-compliant Protection System Maintenance Program for its applicable Protection Systems by April 1, 2015. However, the PRC-005-2 implementation plan established a phased compliance schedule for allowing entities to transition their maintenance activities for Protection System components to PRC-005-2 over time.

3. PRC-005-3

The Commission approved PRC-005-3 on January 22, 2015 in Order No. 803.²⁹ PRC-005-3 revised PRC-005-2 to require applicable entities to test and maintain certain autoreclosing relays as part of their Protection System Maintenance Programs.³⁰ In Order No. 803, the Commission also directed further revisions to the PRC-005 Reliability Standard which are, in part, the subject of this petition.

²⁸ *Protection System Maintenance Reliability Standard*, Order No. 793, 145 FERC ¶ 61,253 (2013) (“Order No. 793”).

²⁹ Order No. 803 at P 17.

³⁰ In Order No. 758, the Commission directed NERC to “include maintenance and testing of reclosing relays that can affect the reliable operation of the Bulk-Power System” within its PRC-005 standard revision efforts. Order No. 758 at P 27.

NERC carried forward the phased implementation approach of PRC-005-2 in the PRC-005-3 implementation plan, adding new provisions to address the addition of Automatic Reclosing Components. Under this plan, applicable entities continue to calculate their compliance dates for Protection System Components based on the regulatory approval date of PRC-005-2, but calculate their compliance dates for Automatic Reclosing Components based on the regulatory approval date of PRC-005-3.

4. PRC-005-2(i), PRC-005-3(i)

On May 29, 2015, the Commission approved PRC-005-2(i) and PRC-005-3(i), which revised PRC-005-2 and PRC-005-3 to address applicability to dispersed power producing resources.³¹ Under the PRC-005-2(i) implementation plan, PRC-005-2(i) immediately became mandatory and enforceable and is the currently-effective version of the PRC-005 standard. Under its implementation plan, PRC-005-3(i) is to become effective the first day following the effective date of PRC-005-3.

The implementation plans for PRC-005-2(i) and PRC-005-3(i) incorporated by reference the phased implementation plans of PRC-005-2 and PRC-005-3 respectively, which are described above.

5. PRC-005-2(ii) and PRC-005-3(ii)

On February 3, 2015, NERC submitted a petition seeking approval of proposed PRC-005-2(ii) and PRC-005-3(ii). The proposed standards, which were developed as part of a broader effort to develop a clearer, more detailed definition of “Remedial Action Scheme,” replace the

³¹ Letter Order, *N. Am. Elec. Reliability Corp.*, 151 FERC ¶ 61,186 (2015).

term “Special Protection System” with “Remedial Action Scheme” where it appears in PRC-005.³² This petition is pending.

The implementation of these proposed versions is addressed in the proposed Remedial Action Scheme implementation plan. Under this plan, the proposed versions would become effective the first day of the first calendar quarter that is 12 months after regulatory approval, if not already retired by an implementation plan for a successor version.

6. PRC-005-4

The Commission approved PRC-005-4 in Order No. 813 issued September 17, 2015.³³ PRC-005-4 revised PRC-005-3 to require applicable entities to maintain certain sudden pressure relays that can affect the reliable operation of the Bulk-Power System as part of their Protection System Maintenance Programs.³⁴

While PRC-005-4 was in development, a separate standard drafting team was developing revisions to versions 2 and 3 of the standard to address applicability to dispersed power producing resources (PRC-005-2(i) and PRC-005-3(i)). However, due to the timing of the various ballot and comment periods and approvals, PRC-005-4 did not reflect the applicability revisions that were ultimately reflected in PRC-005-2(i) and PRC-005-3(i).³⁵ Both PRC-005-4 and PRC-005-2(i)/-3(i) were adopted by the NERC Board of Trustees on November 13, 2014 and filed with Commission for approval soon after. Development then began on PRC-005-5,

³² *Petition of the North American Electric Reliability Corporation for Approval of Revisions to the Definition of “Remedial Action Scheme” and Proposed Reliability Standards*, Docket No. RM15-13-000 (Feb. 3, 2015).

³³ *See supra* n. 9.

³⁴ PRC-005-4 addressed certain concerns set out by the Commission in Order No. 758 regarding a lack of maintenance requirements for non-electrical sensing relays (such as sudden pressure relays) that could affect the reliable operation of the Bulk-Power System. *See id.* at PP 5 and 22.

³⁵ PRC-005-4 was first posted for comment and ballot from April 17, 2014 – June 3, 2014, and again from July 30, 2014 – September 12, 2014, with the final ballot in October 2014. PRC-005-2(i) and PRC-005-3(i) were first posted for comment and ballot from June 12, 2014 through July 29, 2014, with the final ballot from August 27, 2014 – September 5, 2014.

discussed below, to revise PRC-005-4 to incorporate the dispersed generation resources applicability revisions.

In the PRC-005-4 implementation plan, NERC carried forward the phased implementation approach of previous PRC-005 plans. Pursuant to the PRC-005-4 implementation plan, PRC-005-4 will become effective on January 1, 2016. Entities continue to calculate their compliance dates for Protection System Components and Automatic Reclosing Components based on the regulatory approval dates of PRC-005-2 and PRC-005-3 respectively, while compliance dates for Sudden Pressure Relaying Components are based on the regulatory approval date of PRC-005-4.

7. PRC-005-5

As discussed above, PRC-005-5 was developed to carry forward the dispersed generation resources applicability revisions reflected in PRC-005-2(i) and PRC-005-3(i), but not reflected in PRC-005-4. All three versions were developed through Project 2014-01 Standards Applicability for Dispersed Generation Resources. A brief history of this project and a brief summary of the design and operational characteristics of dispersed generation resources are provided below for reference. For additional information regarding this project and revisions developed to other Reliability Standards as part of this project, please refer to Docket No. RD15-3-000.

a) History of Project 2014-01

Project 2014-01 Standards Applicability for Dispersed Generation Resources was initiated in response to industry request and designed to ensure that the Generator Owners and Generator Operators of dispersed generation resources are appropriately assigned responsibility for performance in NERC Reliability Standard requirements that impact the reliability of the Bulk-Power System, given the unique operating characteristics of these resources. The goal of Project 2014-01 was to review and revise the applicability of all of the Generator Owner- and

Generator Operator-related Reliability Standards and ensure that only those dispersed generation resources that could affect the reliability of the Bulk-Power System are subject to applicable Reliability Standards.

To ensure continuity, Project 2014-01 initiated applicability revisions in three versions of the PRC-005 Reliability Standard. The Commission approved PRC-005-2(i) and PRC-005-3(i), which revised the applicability of PRC-005-2 and PRC-005-3 respectively, in Docket No. RD15-3-000.³⁶ The Project 2014-01 standard drafting team also developed PRC-005-5 to ensure that the PRC-005 standard would continue to be applied appropriately to dispersed generation resources. PRC-005-5 revised the applicability of PRC-005-4, which was developed concurrently with PRC-005-2(i) and PRC-005-3(i) in a separate project. The applicability revisions made in PRC-005-5 were carried through without modification in proposed Reliability Standard PRC-005-6.

b) Design and Operational Characteristics of Dispersed Power Producing Resources

As discussed further in Docket No. RD15-3-000 and the DGR White Paper,³⁷ the Project 2014-01 standard drafting team concluded that the design and operational characteristics of dispersed power producing resources are different than traditional generation. Dispersed power producing resources are typically comprised of many individual generating units and in most cases, the units are similar in design and produced by the same manufacturer. The equipment is often geographically dispersed and the generating capacity of individual generating modules can be as small as a few hundred watts to as large as several megawatts. Dispersed generation resources interconnected to the transmission system typically have a control system that controls

³⁶ See *supra* n. 11 and Section III.C.4.

³⁷ Draft White Paper, *Proposed Revisions to the Applicability of NERC Reliability Standards to Dispersed Generation Resources* (“DGR White Paper”), appended hereto as **Exhibit D**.

voltage and power output of the aggregate facility. The control system is capable of recognizing the capability of each individual unit or inverter included in the facility, to appropriately distribute the volume of generation contribution required of the facility across the available units or inverters and to recognize and account for the variation of uncontrollable factors that affect the individual units, such as wind speed and solar irradiance levels. For efficiency, the facilities are designed to provide the system requirements at the point of interconnection to the transmission system and not at the individual unit level.³⁸

Based on a consideration of the design and operating characteristics of dispersed generation resources, the Project 2014-01 standard drafting team determined that the unavailability or failure of any one individual generating resource may have a negligible impact on the aggregated capability of the facility, and individual resources have limited effect on the reliability of the Bulk-Power System. However, as the aggregated capability of the facility may in some cases contribute to the reliability of the Bulk-Power System, there can be a reliability benefit from ensuring that the equipment utilized to aggregate the individual units to a common point of interconnection with the transmission system is operated and maintained as required by the PRC-005 Reliability Standard.³⁹

D. Project 2007-17.4 PRC-005 FERC Order No. 803 Directive (PRC-005-6)

As noted above, in Order No. 803, the Commission approved Reliability Standard PRC-005-3, which brought certain automatic reclosing devices within the scope of the PRC-005 standard. Automatic reclosing equipment is equipment that provides for automatic reclosing of a switching device as desired after it has opened under abnormal conditions. In the PRC-005-3

³⁸ For this discussion, *see id.* at Section 3.2.

³⁹ *Id.* at Sections 3.2.1, 3.2.3 and 4.10.7.

standard, Automatic Reclosing is defined as having the following two Components: reclosing relay and control circuitry associated with the reclosing relay. In Order No. 803, the Commission directed NERC to develop modifications to the PRC-005-3 Reliability Standard “to include supervisory devices associated with autoreclosing relay schemes to which the Reliability Standard applies.”⁴⁰ Project 2007-17.4 PRC-005 FERC Order No. 803 Directive was initiated in response to this directive.

As explained by the Commission in its Notice of Proposed Rulemaking proposing to approve PRC-005-3, supervisory devices, such as synchronism check or voltage relays, “essentially ‘supervise’ the actions of an autoreclosing scheme. That is, they allow reclosing for desirable conditions or block autoreclosing for undesirable conditions.”⁴¹ The Commission expressed concern that the PRC-005-3 standard did not include supervisory devices that may be critical to the operation of a reclosing scheme.⁴² Therefore, the Commission proposed to direct that NERC develop modifications to PRC-005-3 to address the appropriateness of including supervisory relays under the maintenance and testing provisions of the PRC-005 Reliability Standard.

In its comments on the PRC-005-3 NOPR, NERC acknowledged the issues cited by the Commission and suggested modifying PRC-005-3 to include maintenance of supervision functions for which a failure can result in autoreclosing into a fault and potentially cause

⁴⁰ Order No. 803 at P 31.

⁴¹ *Protection System Maintenance Reliability Standard*, Notice of Proposed Rulemaking, 148 FERC ¶ 61,041 at P 28 (2014) (“PRC-005-3 NOPR”) at 30.

⁴² *Id.* at P 30 (citing Order No. 758 at P 24). In Order No. 758, the Commission stated, “a misoperating or miscoordinated reclosing relay may result in the reclosure of a Bulk-Power System element back onto a fault or that a misoperating or miscoordinated reclosing relay may fail to operate after a fault has been cleared, thus failing to restore the element to service.” Misoperated or miscoordinated relays, the Commission explained, may result in damage to the Bulk-Power System, such as excessive shaft torques and winding stresses and exposure of circuit breakers to systems conditions less than optimal for correct operation.

generating unit or plant instability. NERC stated that it would support the addition of voltage supervision, supervisory inputs associated with selective autoreclosing (where used), and synchronism check supervision in the PRC-005 Reliability Standard.⁴³

In Order No. 803, the Commission adopted its NOPR proposal and directed NERC to “develop modifications to PRC-005-3 to include supervisory devices associated with autoreclosing relay schemes to which the Reliability Standard applies.”⁴⁴ The Commission stated that it found “acceptable” NERC’s proposal to limit the scope of supervisory devices to those providing voltage supervision, supervisory inputs associated with selective autoreclosing, and sync-check relays that are part of a reclosing scheme covered by PRC-005-3.⁴⁵

The revisions developed in response to this Order No 803 directive are discussed in the following section.

IV. JUSTIFICATION FOR APPROVAL

As discussed in **Exhibit C** and below, proposed Reliability Standard PRC-005-6 satisfies the Commission’s criteria in Order No. 672, and is just, reasonable, not unduly discriminatory or preferential, and in the public interest. The purpose of the proposed Reliability Standard is to document and implement programs for the maintenance of all Protection Systems, Automatic Reclosing, and Sudden Pressure Relaying affecting the reliability of the Bulk Electric System (or

⁴³ *Comments of the North American Electric Reliability Corporation in Response to Notice of Proposed Rulemaking*, Dkt. No. RM14-8-000 (Sep. 29, 2014) at 4. In its comments, NERC explained that it reviewed the report of the NERC Planning Committee System Analysis and Modeling Subcommittee (“SAMS”) and System Protection and Control Subcommittee (“SPCS”) titled *Considerations for Maintenance and Testing of Autoreclosing Schemes* (“SAMS/SPCS Report”) and consulted with its internal subject matter experts “on which supervisory devices should be included within NERC’s PRC-005 standard to meet the Commission’s concerns raised in the NOPR and ensure entities properly maintain the devices in order to minimize the risk of failure.” *See id.* at n. 4. The SAMS and SPCS jointly performed a technical study to determine which reclosing relays should be addressed within PRC-005 and provided advice to the PRC-005-3 standard drafting team regarding appropriate maintenance intervals and activities for those relays. This report, which was also included as Exhibit D to NERC’s February 14, 2014 petition for approval of PRC-005-3, is appended hereto as **Exhibit H** for ease of reference.

⁴⁴ Order No. 803 at P 31.

⁴⁵ *Id.*

“BES”) so that they are kept in working order. The proposed Reliability Standard enhances reliability and improves upon prior versions of the standard by: (i) extending the coverage of an entity’s Protection System Maintenance Program to include supervisory devices and functions associated with applicable Automatic Reclosing, consistent with Order No. 803; and (ii) ensuring that owners and operators of dispersed generation resources are appropriately subject to the requirements of the PRC-005 standard, consistent with prior Commission-approved revisions to the PRC-005 standard. Proposed Reliability Standard PRC-005-6 adds detailed information regarding minimum maintenance activities and maximum maintenance intervals for supervisory devices or functions associated with Automatic Reclosing, extending the benefits of a strong maintenance program to those Components.

To assist responsible entities in understanding the addition of supervisory devices and functions to the scope of the standard, the Project 2007-17.4 standard drafting team revised the Supplementary Reference and FAQ document (**Exhibit E**) developed concurrently with proposed PRC-005-6. This revised document will be posted with the proposed PRC-005-6 Reliability Standard following approval.

Provided below is a summary of the proposed revisions, including their technical basis and a discussion of prior proceedings, and a discussion of the proposed implementation plan.

A. Revisions to Address the Inclusion of Supervisory Devices

To address the Commission’s Order No. 803 directive, the definition of Automatic Reclosing in Section 6, Definitions Used in this Standard, has been revised to add supervisory relays or functions, the associated voltage sensing devices, and the associated control circuitry. In addition, tables have been revised, and one new table added, to address maintenance activities

and testing for Automatic Reclosing with supervisory relays. Other than reflecting the addition of this new table, no substantive revisions are proposed to the Reliability Standard Requirements.

1. Revised Definitions for Use in the Proposed Standard

The definition of Automatic Reclosing, which is used only within the PRC-005 Reliability Standard and is not proposed for addition to the *Glossary of Terms Used in NERC Reliability Standards*, is revised as follows to address the Commission’s Order No. 803 directive:

6. Definitions Used in this Standard:

Automatic Reclosing – Includes the following Components^[46]

- Reclosing relay
- Supervisory relay(s) or function(s) – relay(s) or function(s) that perform voltage and/or sync check functions that enable or disable operation of the reclosing relay
- Voltage sensing devices associated with the supervisory relay(s) or function(s)
- Control circuitry associated with the reclosing relay or supervisory relay(s) or function(s)

As there are now four specific elements of Automatic Reclosing instead of the previous two, the standard-only definition of Component Type is revised accordingly. In addition, the standard-only definition of Countable Event has been updated to refer to a newly-added table.

The analysis in the SAMS/SPCS Report identified that the failure mode of concern is associated with premature autoreclosing into a fault, which creates the potential for generating unit or plant instability. This may occur due to a timing failure in the autoreclosing relay or when

⁴⁶ The definition of Component as used in the proposed PRC-005-5 and PRC-005-6 standards remains unchanged from the PRC-005-4 Reliability Standard. Component is defined in the PRC-005 standard as follows: “Any individual discrete piece of equipment included in a Protection System, Automatic Reclosing, or Sudden Pressure Relaying.”

a supervision failure results in autoreclosing into a dead-line with a fault when this closing is not intended. Autoreclosing into a fault when dead-line closing is not intended could result from failure of voltage supervision or, when used, failure of a selective autoreclosing input, such as a protective relay output that blocks autoreclosing following a three-phase fault.⁴⁷ Therefore, to address this concern, NERC proposes to add voltage supervision and where used, supervisory inputs associated with selective reclosing, to the list of Automatic Reclosing Components. This will bring these devices within the scope of the PRC-005 Reliability Standard in response to the Commission's directive.

NERC also proposes to add synchronism check supervision to the list of Automatic Reclosing Components. A synchronizing or synchronism ("sync") check relay is a synchronizing device that produces an output that supervises closure of a circuit breaker between two circuits whose voltages are within prescribed limits of magnitude and within the prescribed phase angle for the prescribed time. It may or may not include voltage or speed control. A sync-check relay permits the paralleling of two circuits that are within prescribed (usually wider) limits of voltage magnitude and phase angle for the prescribed time.⁴⁸ Including such devices within the PRC-005 standard provides a reliability benefit. For example, a sync-check device may prevent reclosing of a line into a fault that could cause damage to generator equipment. Maintenance of these devices helps to ensure that they operate correctly in the autoreclosing scheme.

2. Revisions to Tables

The following PRC-005 Tables are revised to include maintenance activities and intervals for supervisory relays:

⁴⁷ See SAMS/SPCS Report (Exhibit H) at 5-7.

⁴⁸ See Ex. E (Supplementary Reference and FAQ – October 2015) at 8.

- Table 4-1, Maintenance Activities and Intervals for Automatic Reclosing Components Component Type – Reclosing and Supervisory Relay;
- Table 4-2(a), Maintenance Activities and Intervals for Automatic Reclosing Components Component Type – Control Circuitry Associated with Reclosing and Supervisory Relays that are NOT an Integral Part of an RAS; and
- Table 4-2(b), Maintenance Activities and Intervals for Automatic Reclosing Components, Component Type – Control Circuitry Associated with Reclosing and Supervisory Relays that ARE an Integral Part of an RAS.

In addition, proposed PRC-005-6 adds a new Table 4-3, Maintenance Activities and Intervals for Automatic Reclosing Components, Component Type – Voltage Sensing Devices Associated with Supervisory Relays. Table references have been updated throughout the standard to reflect the addition of Table 4-3.

The Project 2007-17.4 standard drafting team determined that it was appropriate to assign the same maintenance intervals for the supervisory relays or functions as their associated automatic reclosing relay. The maintenance activity provisions in these tables for supervisory relays or functions are similar in nature to those for other protective functions already existing in the PRC-005 standard.

In addition, a note is added to each of these tables to provide that where Components of Automatic Reclosing are common to Components listed in another specific PRC-005 table, the Components only need to be tested once during a distinct maintenance interval. This note was added to clarify that entities do not need to perform multiple tests on supervisory relays associated with more than one Component.

3. Use of Abbreviation “PSMP”

For readability, PRC-005-6 abbreviates Protection System Maintenance Program as “PSMP” following its first mention in the standard.

B. Dispersed Generation Resources Applicability Revisions (Section 4.2)

Proposed Reliability Standard PRC-005-6 carries forward certain revisions to Section 4, Applicability that were previously approved by the Commission in PRC-005-2(i) and PRC-005-3(i) and by the NERC Board of Trustees in PRC-005-5. These applicability revisions, which were developed through Project 2014-01 Standards Applicability for Dispersed Generation Resources based on the findings of the DGR White Paper, are intended to clarify and provide for consistent application of the standard requirements to Bulk Electric System generator Facilities included in the Bulk Electric System through Inclusion I4 – Dispersed Power Producing Resources.

To accomplish this purpose, PRC-005-4 was modified as follows. Section 4.2.5 was separated, Section 4.2.6 was added, and PRC-005-4 Section 4.2.6 Automatic Reclosing was renumbered to Section 4.2.7, with its subsections renumbered accordingly.

Sections 4.2.5, 4.2.6, and 4.2.7 of PRC-005-4 are revised as follows:

4. Applicability:

4.2. Facilities:

4.2.5 Protection Systems and Sudden Pressure Relaying for generator Facilities that are part of the BES, except for generators identified through Inclusion I4 of the BES definition, including:^[49]

4.2.5.1 Protection Systems that act to trip the generator either directly or via lockout or auxiliary tripping relays.

⁴⁹ In PRC-005-2(i) and PRC-005-3(i), this section reads, “Protection Systems for the following BES generator Facilities for generators not identified through Inclusion I4 of the BES definition”. Based on the comments received, the Project 2014-01 standard drafting team made minor clarification revisions to this section when drafting PRC-005-5. The changes do not alter the intent or operation this section.

4.2.5.2 Protection Systems and Sudden Pressure Relaying for generator step-up transformers for generators that are part of the BES.

~~**4.2.5.3.** Protection Systems and Sudden Pressure Relaying for transformers connecting aggregated generation, where the aggregated generation is part of the BES (e.g., transformers connecting facilities such as wind farms to the BES).~~

~~**4.2.5.4.**~~ **4.2.5.3** Protection Systems and Sudden Pressure Relaying for station service or excitation transformers connected to the generator bus of generators which are part of the BES, that act to trip the generator either directly or via lockout or tripping auxiliary relays.

4.2.6 Protection Systems and Sudden Pressure Relaying for the following BES generator Facilities for dispersed power producing resources identified through Inclusion I4 of the BES definition:

4.2.6.1 Protection Systems and Sudden Pressure Relaying for Facilities used in aggregating dispersed BES generation from the point where those resources aggregate to greater than 75 MVA to a common point of connection at 100kV or above.

4.2.6 **4.2.7** Automatic Reclosing, including:

As described further in Docket No. RD15-3-000 and the DGR White Paper,⁵⁰ the Project 2014-01 standard drafting team concluded that maintenance activities on each individual generating unit at a dispersed generation Facility would not provide any additional reliability benefits to the Bulk-Power System, but maintenance activities on Facilities where generation aggregates to 75 MVA or more would. The proposed revisions are consistent with the Commission-approved revised Bulk Electric System definition and prior revisions made to the PRC-005 standard as reflected in currently-effective PRC-005-2(i) and approved PRC-005-3(i).

⁵⁰ See *Petition of the North American Electric Reliability Corporation for Approval of Proposed Reliability Standards PRC-004-2.1(i)a, PRC-004-4, PRC-005-2(i), PRC-005-3(i), and VAR-002-4*, Docket No. RD15-3-000 (Feb. 6, 2015) at p. 18-22; see also DGR White Paper at P 4.10.7.

C. Proposed Implementation Plan

1. Proposed PRC-005-6 Implementation Plan

The proposed PRC-005-6 implementation plan improves upon previous PRC-005 implementation plans by aligning the dates by which entities must be compliant for all newly-applicable systems. Specifically, the compliance deadlines for the new systems and Components introduced in PRC-005-3, PRC-005-4, and PRC-005-6 would be measured from the regulatory approval date of PRC-005-6, instead of the regulatory approval date of the PRC-005 standard that first brought them in scope. As entities have already begun work to implement protections for Protection System Components under PRC-005-2 and currently-effective PRC-005-2(i), the proposed PRC-005-6 implementation plan would continue implementation for those devices in accordance with the schedule set forth in the PRC-005-2 implementation plan (which is incorporated by reference in the implementation plan for currently-effective PRC-005-2(i)).

Beginning with PRC-005-2, PRC-005 implementation plans have provided a phased implementation approach. Depending on the type of device and specific requirement, implementation is divided into phases, requiring registered entities to gradually ensure compliance of a percentage of their devices until they reach 100% compliance. In the PRC-005-3 and PRC-005-4 implementation plans, NERC carried forward this phased approach. However, recognizing that entities would need a reasonable period of time to incorporate Automatic Reclosing and Sudden Pressure Relaying into their Protection System Maintenance Programs, these implementation plans also provided a phased approach for compliance based on the date of regulatory approval for the standard version that brought these systems in scope. To demonstrate, in the implementation plan for PRC-005-4, entities would be required to calculate their compliance dates for their Protection System, Automatic Reclosing, and Sudden Pressure

Relaying Components from the regulatory approval dates of PRC-005-2, PRC-005-3, and PRC-005-4, respectively.

NERC now proposes to include additional in-scope Components in proposed Reliability Standard PRC-005-6. If the previous implementation approach was continued for PRC-005-6, registered entities would be required to perform three consecutive updates to their Protection System Maintenance Programs to address applicable systems and Components added by PRC-005-3, PRC-005-4, and proposed PRC-005-6 within a short time frame; depending on dates of Commission approval, this could potentially be as short as 12-18 months. Updating Protection System Maintenance Programs is expected to be a time-consuming task for many entities. This short period of time for review and identification of all assets subject to the various PRC-005 versions could lead to errors, omissions, and misidentification of devices. In addition, this approach would require entities to manage multiple PRC-005 compliance schedules for a number of years, increasing the potential for confusion and missed devices which could in turn lead to a decrease in the reliability of the affected devices.

The Project 2007-17.4 standard drafting team determined that a more streamlined implementation approach was needed to govern implementation of proposed PRC-005-6. As proposed PRC-005-6 reflects all revisions in prior versions of PRC-005 (PRC-005-2(ii),⁵¹ PRC-005-3, PRC-005-3(i), PRC-005-3(ii), PRC-005-4, and PRC-005-5), NERC proposes to transition directly from currently-effective PRC-005-2(i) to proposed PRC-005-6.

To allow entities sufficient time to address all new applicable systems in their Protection System Maintenance Program revisions, including the supervisory devices introduced in

⁵¹ Specifically, proposed Reliability Standard PRC-005-6 – like approved Reliability Standard PRC-005-4 – uses the defined term “Remedial Action Scheme” instead of the defined term “Special Protection System” that was used in previous PRC-005 standard versions.

proposed PRC-005-6, this approach necessitates a slight delay in implementing requirements for applicable systems that were introduced in previous PRC-005 versions.⁵² As a corresponding change, the revised definition of Protection System Maintenance Program (PSMP), which in its most recent form was approved for inclusion in the Glossary in Docket No. RM15-9-000 (PRC-005-4),⁵³ would become effective when PRC-005-6 becomes effective.

This proposed implementation approach would provide several important benefits that would justify any delay necessary for its implementation. First, by aligning compliance dates for all newly-applicable systems, NERC's proposed PRC-005-6 implementation plan would provide for the development of comprehensive Protection System Maintenance Programs informed by the whole of NERC's PRC-005 efforts to date. These comprehensive programs would be less likely to contain errors, omissions, and misidentified devices, thereby promoting reliability. Second, this approach would streamline the PRC-005 compliance date schedules for all new

⁵² In Order No. 803 approving PRC-005-3, the Commission directed NERC "to obtain, maintain, and make available to the Commission upon request, one year following the effective date of the standard and on an annual basis thereafter, data sufficient to analyze the effectiveness of PRC-005-3" Under the proposed implementation plan for PRC-005-6, implementation of requirements for Automatic Reclosing would be governed according to a new, consolidated implementation timeline. Therefore, NERC respectfully requests that, if the Commission approves the proposed PRC-005-6 implementation plan, the Commission also clarify that NERC's Order No. 803 data collection obligations would begin one year following the effective date of PRC-005-6.

⁵³ The approved revised definition of Protection System Maintenance Program revises the currently-effective definition to provide for Automatic Reclosing and Sudden Pressure Relaying Components. The definition is as follows:

An ongoing program by which Protection System, Automatic Reclosing, and Sudden Pressure Relaying Components are kept in working order and proper operation of malfunctioning Components is restored. A maintenance program for a specific Component includes one or more of the following activities:

- Verify — Determine that the Component is functioning correctly.
- Monitor — Observe the routine in-service operation of the Component.
- Test — Apply signals to a Component to observe functional performance or output behavior, or to diagnose problems.
- Inspect — Examine for signs of Component failure, reduced performance or degradation.
- Calibrate — Adjust the operating threshold or measurement accuracy of a measuring element to meet the intended performance requirement.

systems, decreasing the potential for confusion and missed device testing. Third, by eliminating the need to create and audit multiple, successive revisions to entity Protection System Maintenance Programs, this approach would promote the efficient use of both registered entity and ERO Enterprise resources. Lastly, this approach would allow NERC additional time to conduct outreach and provide training to registered entities so that they are well aware and prepared to meet their obligations under this important Reliability Standard, further promoting reliability.

The proposed PRC-005-6 implementation plan represents a reasonable approach that balances the urgency in the need to implement these important protections while recognizing the challenges that multiple, successive program revisions and compliance date schedules may pose to registered entities.

2. Retirement of Previous PRC-005 Standards

As NERC proposes transition directly to PRC-005-6 from currently-effective PRC-005-2(i), NERC proposes to retire all intermediate PRC-005 standard versions. This includes currently-effective PRC-005-2(i), Commission-approved but not yet effective versions PRC-005-3, PRC-005-3(i), and PRC-005-4, pending versions PRC-005-2(ii) and PRC-005-3(ii), and PRC-005-5, which is addressed in this petition. The implementation plan continues to reflect that the retirement of the legacy Reliability Standards PRC-005-1.1b,⁵⁴ PRC-008-0, PRC-011-0, and PRC-017-0 will be based off the regulatory approval date of PRC-005-2.

⁵⁴ PRC-005-1.1b, which was approved on September 19, 2013 and became mandatory and enforceable on November 25, 2013, retired the prior-approved version PRC-005-1b referenced in previous PRC-005 implementation plans. Therefore, the proposed PRC-005-6 implementation refers to PRC-005-1.1b.

D. Alternate Proposal to Approve PRC-005-5

As noted above, PRC-005-5 was adopted by the NERC Board of Trustees to carry forward the dispersed generation resources applicability provisions from currently-effective PRC-005-2(i) and approved PRC-005-3(i) with only minor clarification revisions. These revisions, which are incorporated without further modifications in proposed PRC-005-6, are described in Section IV.B above.

Should the Commission decline to approve proposed PRC-005-6 for reasons specific to that version of the standard, such as the inclusion of supervisory devices or the proposed implementation plan, NERC respectfully requests that the Commission approve PRC-005-5 (**Exhibit A-2**) and the PRC-005-5 implementation plan (**Exhibit B-2**). The PRC-005-5 implementation plan provides that PRC-005-5 shall become effective the later of: (i) the first day following the effective date of PRC-005-4; or (ii) the first day following approval by an applicable governmental authority. Approving PRC-005-5 would ensure that the PRC-005 standard would continue to be applied consistently and appropriately to dispersed generation resources while NERC is addressing any issues specific to PRC-005-6.

V. ENFORCEABILITY OF THE PROPOSED RELIABILITY STANDARD

The proposed Reliability Standards contain Violation Risk Factors (“VRFs”) and Violation Severity Levels (“VSLs”). The VSLs provide guidance on the way that NERC will enforce the Requirements of the proposed Reliability Standard. The VRFs are one of several elements used to determine an appropriate sanction when the associated Requirement is violated. The VRFs assess the impact to reliability of violating a specific Requirement.

The proposed Reliability Standard also includes Measures that support each Requirement by clearly identifying what is required and how the Requirement will be enforced. These

Measures help ensure that the Requirements will be enforced in a clear, consistent, and non-preferential manner and without prejudice to any party.⁵⁵

Proposed PRC-005-6 includes corresponding changes, where necessary, to the VRFs and VSLs to align with the revisions in proposed PRC-005-6. The VRFs and VSLs comport with NERC and Commission guidelines related to their assignment. A detailed review of the VRFs, VSLs, and the analysis of how the VRFs and VSLs were determined using these guidelines is provided in **Exhibit G**.

Because the Requirements contained in proposed Reliability Standard PRC-005-6 track with those contained in the previous versions, the Project 2007-17.4 standard drafting team determined that no revisions were necessary to the VRFs for the proposed Reliability Standard. NERC, therefore, requests that the Commission approve the VRFs as applied to the supervisory devices now included in the proposed Reliability Standard as Automatic Reclosing Components.

The VSLs in PRC-005-6 have been revised accordingly to address the supervisory devices now included in the proposed Reliability Standard as Automatic Reclosing Components in the levels of severity. The changes are consistent with the approach taken for the VSLs in Reliability Standard PRC-005-4. The VSLs provide guidance on the way that NERC will enforce the Requirements of the proposed Reliability Standard for each of the Component Types. The Measures for proposed PRC-005-6 have been similarly revised.

⁵⁵ Order No. 672 at P 327 (“There should be a clear criterion or measure of whether an entity is in compliance with a proposed Reliability Standard. It should contain or be accompanied by an objective measure of compliance so that it can be enforced and so that enforcement can be applied in a consistent and non-preferential manner.”).

VI. CONCLUSION

For the reasons set forth above, NERC respectfully requests that the Commission:

- approve proposed Reliability Standard PRC-005-6 and associated elements included in Exhibit A-1;
- approve the implementation plan included in Exhibit B-1a; and
- approve the retirement of previous versions of the PRC-005 Reliability Standard as set forth in the PRC-005-6 implementation plan.

Respectfully submitted,

/s/ Lauren A. Perotti

Charles A. Berardesco
Senior Vice President and General Counsel
Holly A. Hawkins
Associate General Counsel
Lauren A. Perotti
Counsel
North American Electric Reliability Corporation
1325 G Street, N.W., Suite 600
Washington, D.C. 20005
(202) 400-3000
(202) 644-8099– facsimile
charles.berardesco@nerc.net
holly.hawkins@nerc.net
lauren.perotti@nerc.net

*Counsel for the North American Electric
Reliability Corporation*

November 13, 2015

Exhibit A

Proposed Reliability Standard PRC-005-6 and Alternative Proposed Standard PRC-005-5

Exhibit A-1

**Proposed Reliability Standard PRC-005-6 (Clean and Redline [PRC-005-6 to PRC-005-4]
& [PRC-005-4 to PRC-005-5])**

Clean Version

Reliability Standard PRC-005-6

A. Introduction

1. **Title:** Protection System, Automatic Reclosing, and Sudden Pressure Relaying Maintenance
2. **Number:** PRC-005-6
3. **Purpose:** To document and implement programs for the maintenance of all Protection Systems, Automatic Reclosing, and Sudden Pressure Relaying affecting the reliability of the Bulk Electric System (BES) so that they are kept in working order.
4. **Applicability:**
 - 4.1. **Functional Entities:**
 - 4.1.1 Transmission Owner
 - 4.1.2 Generator Owner
 - 4.1.3 Distribution Provider
 - 4.2. **Facilities:**
 - 4.2.1 Protection Systems and Sudden Pressure Relaying that are installed for the purpose of detecting Faults on BES Elements (lines, buses, transformers, etc.)
 - 4.2.2 Protection Systems used for underfrequency load-shedding systems installed per ERO underfrequency load-shedding requirements.
 - 4.2.3 Protection Systems used for undervoltage load-shedding systems installed to prevent system voltage collapse or voltage instability for BES reliability.
 - 4.2.4 Protection Systems installed as a Remedial Action Scheme (RAS) for BES reliability.
 - 4.2.5 Protection Systems and Sudden Pressure Relaying for generator Facilities that are part of the BES, except for generators identified through Inclusion I4 of the BES definition, including:
 - 4.2.5.1 Protection Systems that act to trip the generator either directly or via lockout or auxiliary tripping relays.
 - 4.2.5.2 Protection Systems and Sudden Pressure Relaying for generator step-up transformers for generators that are part of the BES.
 - 4.2.5.3 Protection Systems and Sudden Pressure Relaying for station service or excitation transformers connected to the generator bus of generators which are part of the BES, that act to trip the generator either directly or via lockout or tripping auxiliary relays.

4.2.6 Protection Systems and Sudden Pressure Relaying for the following BES generator Facilities for dispersed power producing resources identified through Inclusion I4 of the BES definition:

4.2.6.1 Protection Systems and Sudden Pressure Relaying for Facilities used in aggregating dispersed BES generation from the point where those resources aggregate to greater than 75 MVA to a common point of connection at 100kV or above.

4.2.7 Automatic Reclosing¹, including:

4.2.7.1 Automatic Reclosing applied on the terminals of Elements connected to the BES bus located at generating plant substations where the total installed gross generating plant capacity is greater than the gross capacity of the largest BES generating unit within the Balancing Authority Area or, if a member of a Reserve Sharing Group, the largest generating unit within the Reserve Sharing Group.²

4.2.7.2 Automatic Reclosing applied on the terminals of all BES Elements at substations one bus away from generating plants specified in Section 4.2.7.1 when the substation is less than 10 circuit-miles from the generating plant substation.

4.2.7.3 Automatic Reclosing applied as an integral part of an RAS specified in Section 4.2.4.

5. Effective Date: See the Implementation Plan for this standard.

6. Definitions Used in this Standard:

Automatic Reclosing – Includes the following Components:

- Reclosing relay
- Supervisory relay(s) or function(s) – relay(s) or function(s) that perform voltage and/or sync check functions that enable or disable operation of the reclosing relay
- Voltage sensing devices associated with the supervisory relay(s) or function(s)

¹ Automatic Reclosing addressed in Section 4.2.7.1 and 4.2.7.2 may be excluded if the equipment owner can demonstrate that a close-in three-phase fault present for twice the normal clearing time (capturing a minimum trip-close-trip time delay) does not result in a total loss of gross generation in the Interconnection exceeding the gross capacity of the largest relevant BES generating unit where the Automatic Reclosing is applied.

² The largest BES generating unit within the Balancing Authority Area or the largest generating unit within the Reserve Sharing Group, as applicable, is subject to change. As a result of such a change, the Automatic Reclosing Components subject to the standard could change effective on the date of such change.

- Control circuitry associated with the reclosing relay or supervisory relay(s) or function(s)

Sudden Pressure Relaying – A system that trips an interrupting device(s) to isolate the equipment it is monitoring and includes the following Components:

- Fault pressure relay – a mechanical relay or device that detects rapid changes in gas pressure, oil pressure, or oil flow that are indicative of Faults within liquid-filled, wire-wound equipment
- Control circuitry associated with a fault pressure relay

Unresolved Maintenance Issue – A deficiency identified during a maintenance activity that causes the Component to not meet the intended performance, cannot be corrected during the maintenance interval, and requires follow-up corrective action.

Segment – Components of a consistent design standard, or a particular model or type from a single manufacturer that typically share other common elements. Consistent performance is expected across the entire population of a Segment. A Segment must contain at least sixty (60) individual Components.

Component Type –

- Any one of the five specific elements of a Protection System
- Any one of the four specific elements of Automatic Reclosing
- Any one of the two specific elements of Sudden Pressure Relaying

Component – Any individual discrete piece of equipment included in a Protection System, Automatic Reclosing, or Sudden Pressure Relaying.

Countable Event – A failure of a Component requiring repair or replacement, any condition discovered during the maintenance activities in Tables 1-1 through 1-5, Table 3, Tables 4-1 through 4-3, and Table 5, which requires corrective action or a Protection System Misoperation attributed to hardware failure or calibration failure. Misoperations due to product design errors, software errors, relay settings different from specified settings, Protection System Component, Automatic Reclosing, or Sudden Pressure Relaying configuration or application errors are not included in Countable Events.

B. Requirements and Measures

- R1.** Each Transmission Owner, Generator Owner, and Distribution Provider shall establish a Protection System Maintenance Program (PSMP) for its Protection Systems, Automatic Reclosing, and Sudden Pressure Relaying identified in Section 4.2, Facilities. *[Violation Risk Factor: Medium] [Time Horizon: Operations Planning]*

The PSMP shall:

- 1.1.** Identify which maintenance method (time-based, performance-based per PRC-005 Attachment A, or a combination) is used to address each Protection System, Automatic Reclosing, and Sudden Pressure Relaying Component Type. All batteries associated with the station dc supply Component Type of a Protection System shall be included in a time-based program as described in Table 1-4 and Table 3.
 - 1.2.** Include the applicable monitored Component attributes applied to each Protection System, Automatic Reclosing, and Sudden Pressure Relaying Component Type consistent with the maintenance intervals specified in Tables 1-1 through 1-5, Table 2, Table 3, Table 4-1 through 4-3, and Table 5 where monitoring is used to extend the maintenance intervals beyond those specified for unmonitored Protection System, Automatic Reclosing, and Sudden Pressure Relaying Components.
- M1.** Each Transmission Owner, Generator Owner and Distribution Provider shall have a documented PSMP in accordance with Requirement R1.
- For each Protection System, Automatic Reclosing, and Sudden Pressure Relaying Component Type, the documentation shall include the type of maintenance method applied (time-based, performance-based, or a combination of these maintenance methods), and shall include all batteries associated with the station dc supply Component Types in a time-based program as described in Table 1-4 and Table 3. (Part 1.1)
- For Component Types that use monitoring to extend the maintenance intervals, the responsible entity(s) shall have evidence for each Protection System, Automatic Reclosing, and Sudden Pressure Relaying Component Type (such as manufacturer's specifications or engineering drawings) of the appropriate monitored Component attributes as specified in Tables 1-1 through 1-5, Table 2, Table 3, Table 4-1 through 4-3, and Table 5. (Part 1.2)
- R2.** Each Transmission Owner, Generator Owner, and Distribution Provider that uses performance-based maintenance intervals in its PSMP shall follow the procedure established in PRC-005 Attachment A to establish and maintain its performance-based intervals. *[Violation Risk Factor: Medium] [Time Horizon: Operations Planning]*
- M2.** Each Transmission Owner, Generator Owner, and Distribution Provider that uses performance-based maintenance intervals shall have evidence that its current performance-based maintenance program(s) is in accordance with Requirement R2, which may include, but is not limited to, Component lists, dated maintenance records, and dated analysis records and results.
- R3.** Each Transmission Owner, Generator Owner, and Distribution Provider that utilizes time-based maintenance program(s) shall maintain its Protection System, Automatic Reclosing, and Sudden Pressure Relaying Components that are included within the

time-based maintenance program in accordance with the minimum maintenance activities and maximum maintenance intervals prescribed within Tables 1-1 through 1-5, Table 2, Table 3, Table 4-1 through 4-3, and Table 5. *[Violation Risk Factor: High]*
[Time Horizon: Operations Planning]

- M3.** Each Transmission Owner, Generator Owner, and Distribution Provider that utilizes time-based maintenance program(s) shall have evidence that it has maintained its Protection System, Automatic Reclosing, and Sudden Pressure Relaying Components included within its time-based program in accordance with Requirement R3. The evidence may include, but is not limited to, dated maintenance records, dated maintenance summaries, dated check-off lists, dated inspection records, or dated work orders.
- R4.** Each Transmission Owner, Generator Owner, and Distribution Provider that utilizes performance-based maintenance program(s) in accordance with Requirement R2 shall implement and follow its PSMP for its Protection System, Automatic Reclosing, and Sudden Pressure Relaying Components that are included within the performance-based program(s). *[Violation Risk Factor: High]* *[Time Horizon: Operations Planning]*
- M4.** Each Transmission Owner, Generator Owner, and Distribution Provider that utilizes performance-based maintenance intervals in accordance with Requirement R2 shall have evidence that it has implemented the PSMP for the Protection System, Automatic Reclosing, and Sudden Pressure Relaying Components included in its performance-based program in accordance with Requirement R4. The evidence may include, but is not limited to, dated maintenance records, dated maintenance summaries, dated check-off lists, dated inspection records, or dated work orders.
- R5.** Each Transmission Owner, Generator Owner, and Distribution Provider shall demonstrate efforts to correct identified Unresolved Maintenance Issues. *[Violation Risk Factor: Medium]* *[Time Horizon: Operations Planning]*
- M5.** Each Transmission Owner, Generator Owner, and Distribution Provider shall have evidence that it has undertaken efforts to correct identified Unresolved Maintenance Issues in accordance with Requirement R5. The evidence may include, but is not limited to, work orders, replacement Component orders, invoices, project schedules with completed milestones, return material authorizations (RMAs) or purchase orders.

C. Compliance

1. Compliance Monitoring Process

1.1. Compliance Enforcement Authority

As defined in the NERC Rules of Procedure, “Compliance Enforcement Authority” means NERC or the Regional Entity in their respective roles of monitoring and enforcing compliance with the NERC Reliability Standards.

1.2. Evidence Retention

The following evidence retention periods identify the period of time an entity is required to retain specific evidence to demonstrate compliance. For instances where the evidence retention period specified below is shorter than the time since the last audit, the Compliance Enforcement Authority may ask an entity to provide other evidence to show that it was compliant for the full time period since the last audit.

The Transmission Owner, Generator Owner, and Distribution Provider shall each keep data or evidence to show compliance as identified below unless directed by its Compliance Enforcement Authority to retain specific evidence for a longer period of time as part of an investigation.

For Requirement R1, the Transmission Owner, Generator Owner, and Distribution Provider shall each keep its current dated PSMP, as well as any superseded versions since the preceding compliance audit, including the documentation that specifies the type of maintenance program applied for each Protection System, Automatic Reclosing, or Sudden Pressure Relaying Component Type.

For Requirement R2, Requirement R3, and Requirement R4, in cases where the interval of the maintenance activity is longer than the audit cycle, the Transmission Owner, Generator Owner, and Distribution Provider shall each keep documentation of the most recent performance of that maintenance activity for the Protection System, Automatic Reclosing, or Sudden Pressure Relaying Component. In cases where the interval of the maintenance activity is shorter than the audit cycle, documentation of all performances (in accordance with the tables) of that maintenance activity for the Protection System, Automatic Reclosing, or Sudden Pressure Relaying Component since the previous scheduled audit date shall be retained.

For Requirement R5 the Transmission Owner, Generator Owner, and Distribution Provider shall each keep documentation of Unresolved Maintenance Issues identified by the entity since the last audit, including all that were resolved since the last audit.

1.3. Compliance Monitoring and Assessment Processes:

Compliance Audits

Self-Certifications

Spot Checking

Compliance Investigations

Self-Reporting

Complaints

1.4. Additional Compliance Information

None

Table of Compliance Elements

Requirement Number	Lower VSL	Moderate VSL	High VSL	Severe VSL
R1	The entity’s PSMP failed to specify whether one Component Type is being addressed by time-based or performance-based maintenance, or a combination of both (Part 1.1).	The entity’s PSMP failed to specify whether two Component Types are being addressed by time-based or performance-based maintenance, or a combination of both (Part 1.1).	<p>The entity’s PSMP failed to specify whether three Component Types are being addressed by time-based or performance-based maintenance, or a combination of both. (Part 1.1).</p> <p>OR</p> <p>The entity’s PSMP failed to include the applicable monitoring attributes applied to each Component Type consistent with the maintenance intervals specified in Tables 1-1 through 1-5, Table 2, Table 3, Tables 4-1 through 4-3, and Table 5 where monitoring is used to extend the maintenance intervals beyond those specified for unmonitored Components (Part 1.2).</p>	<p>The entity failed to establish a PSMP.</p> <p>OR</p> <p>The entity’s PSMP failed to specify whether four or more Component Types are being addressed by time-based or performance-based maintenance, or a combination of both (Part 1.1).</p> <p>OR</p> <p>The entity’s PSMP failed to include applicable station batteries in a time-based program (Part 1.1).</p>
R2	The entity uses performance-based maintenance intervals in its PSMP but failed to reduce Countable Events to no more than 4% within three years.	NA	The entity uses performance-based maintenance intervals in its PSMP but failed to reduce Countable Events to no more than 4% within four years.	<p>The entity uses performance-based maintenance intervals in its PSMP but:</p> <ol style="list-style-type: none"> 1) Failed to establish the technical justification described within Requirement R2 for the initial use of the performance-based PSMP <p>OR</p> <ol style="list-style-type: none"> 2) Failed to reduce Countable Events to no more than 4% within five years <p>OR</p>

Requirement Number	Lower VSL	Moderate VSL	High VSL	Severe VSL
				3) Maintained a Segment with less than 60 Components OR 4) Failed to: <ul style="list-style-type: none"> • Annually update the list of Components, OR • Annually perform maintenance on the greater of 5% of the Segment population or 3 Components, OR • Annually analyze the program activities and results for each Segment.
R3	For Components included within a time-based maintenance program, the entity failed to maintain 5% or less of the total Components included within a specific Component Type in accordance with the minimum maintenance activities and maximum maintenance intervals prescribed within Tables 1-1 through 1-5, Table 2, Table 3, Tables 4-1 through 4-3, and Table 5.	For Components included within a time-based maintenance program, the entity failed to maintain more than 5% but 10% or less of the total Components included within a specific Component Type in accordance with the minimum maintenance activities and maximum maintenance intervals prescribed within Tables 1-1 through 1-5, Table 2, Table 3, Tables 4-1 through 4-3, and Table 5.	For Components included within a time-based maintenance program, the entity failed to maintain more than 10% but 15% or less of the total Components included within a specific Component Type in accordance with the minimum maintenance activities and maximum maintenance intervals prescribed within Tables 1-1 through 1-5, Table 2, Table 3, Tables 4-1 through 4-3, and Table 5.	For Components included within a time-based maintenance program, the entity failed to maintain more than 15% of the total Components included within a specific Component Type in accordance with the minimum maintenance activities and maximum maintenance intervals prescribed within Tables 1-1 through 1-5, Table 2, Table 3, Tables 4-1 through 4-3, and Table 5.

Requirement Number	Lower VSL	Moderate VSL	High VSL	Severe VSL
R4	For Components included within a performance-based maintenance program, the entity failed to maintain 5% or less of the annual scheduled maintenance for a specific Component Type in accordance with their performance-based PSMP.	For Components included within a performance-based maintenance program, the entity failed to maintain more than 5% but 10% or less of the annual scheduled maintenance for a specific Component Type in accordance with their performance-based PSMP.	For Components included within a performance-based maintenance program, the entity failed to maintain more than 10% but 15% or less of the annual scheduled maintenance for a specific Component Type in accordance with their performance-based PSMP.	For Components included within a performance-based maintenance program, the entity failed to maintain more than 15% of the annual scheduled maintenance for a specific Component Type in accordance with their performance-based PSMP.
R5	The entity failed to undertake efforts to correct 5 or fewer identified Unresolved Maintenance Issues.	The entity failed to undertake efforts to correct greater than 5 but less than or equal to 10 identified Unresolved Maintenance Issues.	The entity failed to undertake efforts to correct greater than 10 but less than or equal to 15 identified Unresolved Maintenance Issues.	The entity failed to undertake efforts to correct greater than 15 identified Unresolved Maintenance Issues.

D. Regional Variances

None.

E. Interpretations

None.

Supplemental Reference Documents

The following documents present a detailed discussion about determination of maintenance intervals and other useful information regarding establishment of a maintenance program.

1. *Supplementary Reference and FAQ - PRC-005-6 Protection System Maintenance*, Protection System Maintenance and Testing Standard Drafting Team (July 2015)
2. *Considerations for Maintenance and Testing of Auto-reclosing Schemes*, NERC System Analysis and Modeling Subcommittee, and NERC System Protection and Control Subcommittee (November 2012)
3. *Sudden Pressure Relays and Other Devices that Respond to Non-Electrical Quantities – SPCS Input for Standard Development in Response to FERC Order No. 758*, NERC System Protection and Control Subcommittee (December 2013)
4. *Sudden Pressure Relays and Other Devices that Respond to Non-Electrical Quantities – Supplemental Information to Support Project 2007-17.3: Protection System Maintenance and Testing* (October 31, 2014)

Version History

Version	Date	Action	Change Tracking
0	February 8, 2005	Adopted by NERC Board of Trustees	New
1	February 7, 2006	Adopted by NERC Board of Trustees	<ol style="list-style-type: none"> 1. Changed incorrect use of certain hyphens (-) to “en dash” (–) and “em dash (—).” 2. Added “periods” to items where appropriate. Changed “Timeframe” to “Time Frame” in item D, 1.2.
1	March 16, 2007	PRC-005-1 Approved by FERC. Docket No. RM06-16-000	

Version	Date	Action	Change Tracking
1a	February 17, 2011	Adopted by NERC Board of Trustees	Added Appendix 1 - Interpretation regarding applicability of standard to protection of radially connected transformers developed in Project 2009-17
1a	September 26, 2011	Approved by FERC. Docket No. RD11-5-000	
1b	November 5, 2009	Adopted by NERC Board of Trustees	Interpretation of R1, R1.1, and R1.2 developed by Project 2009-10
1b	February 3, 2012	FERC Order approving revised definition of “Protection System”	Per footnote 8 of FERC’s order, the definition of “Protection System” supersedes interpretation “b” of PRC-005-1b upon the effective date of the modified definition (i.e., April 1, 2013) <i>See N. Amer. Elec. Reliability Corp., 138 FERC ¶ 61,095 (February 3, 2012).</i>
1b	February 3, 2012	PRC-005-1b Approved by FERC. Docket No. RM10-5-000	
1.1b	May 9, 2012	Adopted by NERC Board of Trustees	Errata change developed by Project 2010-07, clarified inclusion of generator interconnection Facility in Generator Owner’s responsibility
1.1b	September 19, 2013	PRC-005-1.1b Approved by FERC. Docket No. RM12-16-000	
2	November 7, 2012	Adopted by NERC Board of Trustees	Project 2007-17 - Complete revision, absorbing maintenance requirements from PRC-005-1.1b, PRC-008-0, PRC-011-0, PRC-017-0

Version	Date	Action	Change Tracking
2	October 17, 2013	Approved by NERC Standards Committee	Errata Change: The Standards Committee approved an errata change to the implementation plan for PRC-005-2 to add the phrase “or as otherwise made effective pursuant to the laws applicable to such ERO governmental authorities;” to the second sentence under the “Retirement of Existing Standards” section. (no change to standard version number)
2	December 19, 2013	PRC-005-2 Approved by FERC. Docket No. RM13-7-000	
2	March 7, 2014	Adopted by NERC Board of Trustees	Modified R1 VSL in response to FERC directive (no change to standard version number)
2(i)	November 13, 2014	Adopted by NERC Board of Trustees	Applicability section revised by Project 2014-01 to clarify application of Requirements to BES dispersed power producing resources
2(i)	May 29, 2015	PRC-005-2(i) Approved by FERC. Docket No. RD15-3-000	
2(ii)	November 13, 2014	Adopted by NERC Board of Trustees	Replaced references to Special Protection System and SPS with Remedial Action Scheme and RAS
3	November 7, 2013	Adopted by the NERC Board of Trustees	Revised to address the FERC directive in Order No. 758 to include Automatic Reclosing in maintenance programs

Version	Date	Action	Change Tracking
3	February 12, 2014	Approved by NERC Standards Committee	Errata Change: The Standards Committee approved errata changes to correct capitalization of certain defined terms within the definitions of “Unresolved Maintenance Issue” and “Protection System Maintenance Program”. The changes will be reflected in the definitions section of PRC-005-3 for “Unresolved Maintenance Issue” and in the NERC Glossary of Terms for “Protection System Maintenance Program”. (no change to standard version number)
3	March 7, 2014	Adopted by NERC Board of Trustees	Modified R1 VSL in response to FERC directive (no change to standard version number)
3	January 22, 2015	PRC-005-3 Approved by FERC. Docket No. RM14-8-000	
3(i)	November 13, 2014	Adopted by NERC Board of Trustees	Applicability section revised by Project 2014-01 to clarify application of Requirements to BES dispersed power producing resources
3(i)	May 29, 2015	PRC-005-3(i) Approved by FERC. Docket No. RD15-3-000	
3(ii)	November 13, 2014	Adopted by NERC Board of Trustees	Replaced references to Special Protection System and SPS with Remedial Action Scheme and RAS
4	November 13, 2014	Adopted by NERC Board of Trustees	Added Sudden Pressure Relaying in response to FERC Order No. 758
4	Sept 17, 2015	PRC-005-4 Approved by FERC. Docket No. RM15-9-000	

Version	Date	Action	Change Tracking
5	May 7, 2015	Adopted by NERC Board of Trustees	Applicability section revised by Project 2014-01 to clarify application of Requirements to BES dispersed power producing resources.
6	November 5, 2015	Adopted by NERC Board of Trustees	Revised to add supervisory relays, the voltage sensing devices, and the associated control circuitry to Automatic Reclosing in accordance with the directives in FERC Order 803.

Table 1-1 Component Type - Protective Relay Excluding distributed UFLS and distributed UVLS (see Table 3)		
Component Attributes	Maximum Maintenance Interval ³	Maintenance Activities
Any unmonitored protective relay not having all the monitoring attributes of a category below.	6 Calendar Years	For all unmonitored relays: <ul style="list-style-type: none"> • Verify that settings are as specified For non-microprocessor relays: <ul style="list-style-type: none"> • Test and, if necessary calibrate For microprocessor relays: <ul style="list-style-type: none"> • Verify operation of the relay inputs and outputs that are essential to proper functioning of the Protection System. • Verify acceptable measurement of power system input values.
Monitored microprocessor protective relay with the following: <ul style="list-style-type: none"> • Internal self-diagnosis and alarming (see Table 2). • Voltage and/or current waveform sampling three or more times per power cycle, and conversion of samples to numeric values for measurement calculations by microprocessor electronics. • Alarming for power supply failure (see Table 2). 	12 Calendar Years	Verify: <ul style="list-style-type: none"> • Settings are as specified. • Operation of the relay inputs and outputs that are essential to proper functioning of the Protection System. • Acceptable measurement of power system input values.

³ For the tables in this standard, a calendar year starts on the first day of a new year (January 1) after a maintenance activity has been completed. For the tables in this standard, a calendar month starts on the first day of the first month after a maintenance activity has been completed.

Table 1-1 Component Type - Protective Relay Excluding distributed UFLS and distributed UVLS (see Table 3)		
Component Attributes	Maximum Maintenance Interval ³	Maintenance Activities
Monitored microprocessor protective relay with preceding row attributes and the following: <ul style="list-style-type: none"> • Ac measurements are continuously verified by comparison to an independent ac measurement source, with alarming for excessive error (See Table 2). • Some or all binary or status inputs and control outputs are monitored by a process that continuously demonstrates ability to perform as designed, with alarming for failure (See Table 2). • Alarming for change of settings (See Table 2). 	12 Calendar Years	Verify only the unmonitored relay inputs and outputs that are essential to proper functioning of the Protection System.

Table 1-2 Component Type - Communications Systems Excluding distributed UFLS and distributed UVLS (see Table 3)		
Component Attributes	Maximum Maintenance Interval	Maintenance Activities
Any unmonitored communications system necessary for correct operation of protective functions, and not having all the monitoring attributes of a category below.	4 Calendar Months	Verify that the communications system is functional.
	6 Calendar Years	Verify that the communications system meets performance criteria pertinent to the communications technology applied (e.g. signal level, reflected power, or data error rate). Verify operation of communications system inputs and outputs that are essential to proper functioning of the Protection System.
Any communications system with continuous monitoring or periodic automated testing for the presence of the channel function, and alarming for loss of function (See Table 2).	12 Calendar Years	Verify that the communications system meets performance criteria pertinent to the communications technology applied (e.g. signal level, reflected power, or data error rate). Verify operation of communications system inputs and outputs that are essential to proper functioning of the Protection System.
Any communications system with all of the following: <ul style="list-style-type: none"> • Continuous monitoring or periodic automated testing for the performance of the channel using criteria pertinent to the communications technology applied (e.g. signal level, reflected power, or data error rate, and alarming for excessive performance degradation). (See Table 2) • Some or all binary or status inputs and control outputs are monitored by a process that continuously demonstrates ability to perform as designed, with alarming for failure (See Table 2). 	12 Calendar Years	Verify only the unmonitored communications system inputs and outputs that are essential to proper functioning of the Protection System

Table 1-3 Component Type - Voltage and Current Sensing Devices Providing Inputs to Protective Relays Excluding distributed UFLS and distributed UVLS (see Table 3)		
Component Attributes	Maximum Maintenance Interval	Maintenance Activities
Any voltage and current sensing devices not having monitoring attributes of the category below.	12 Calendar Years	Verify that current and voltage signal values are provided to the protective relays.
Voltage and Current Sensing devices connected to microprocessor relays with ac measurements that are continuously verified by comparison of sensing input value, as measured by the microprocessor relay, to an independent ac measurement source, with alarming for unacceptable error or failure (see Table 2).	No periodic maintenance specified	None.

Table 1-4(a) Component Type – Protection System Station dc Supply Using Vented Lead-Acid (VLA) Batteries Excluding distributed UFLS and distributed UVLS (see Table 3)		
Protection System Station dc supply used only for non-BES interrupting devices for RAS, non-distributed UFLS systems, or non-distributed UVLS systems is excluded (see Table 1-4(e)).		
Component Attributes	Maximum Maintenance Interval	Maintenance Activities
Protection System Station dc supply using Vented Lead-Acid (VLA) batteries not having monitoring attributes of Table 1-4(f).	4 Calendar Months	Verify: <ul style="list-style-type: none"> • Station dc supply voltage Inspect: <ul style="list-style-type: none"> • Electrolyte level • For unintentional grounds
	18 Calendar Months	Verify: <ul style="list-style-type: none"> • Float voltage of battery charger • Battery continuity • Battery terminal connection resistance • Battery intercell or unit-to-unit connection resistance Inspect: <ul style="list-style-type: none"> • Cell condition of all individual battery cells where cells are visible – or measure battery cell/unit internal ohmic values where the cells are not visible • Physical condition of battery rack

Table 1-4(a) Component Type – Protection System Station dc Supply Using Vented Lead-Acid (VLA) Batteries Excluding distributed UFLS and distributed UVLS (see Table 3)		
Protection System Station dc supply used only for non-BES interrupting devices for RAS, non-distributed UFLS systems, or non-distributed UVLS systems is excluded (see Table 1-4(e)).		
Component Attributes	Maximum Maintenance Interval	Maintenance Activities
	18 Calendar Months -or- 6 Calendar Years	Verify that the station battery can perform as manufactured by evaluating cell/unit measurements indicative of battery performance (e.g. internal ohmic values or float current) against the station battery baseline. -or- Verify that the station battery can perform as manufactured by conducting a performance or modified performance capacity test of the entire battery bank.

Table 1-4(b) Component Type – Protection System Station dc Supply Using Valve-Regulated Lead-Acid (VRLA) Batteries Excluding distributed UFLS and distributed UVLS (see Table 3)		
Protection System Station dc supply used only for non-BES interrupting devices for RAS, non-distributed UFLS systems, or non-distributed UVLS systems is excluded (see Table 1-4(e)).		
Component Attributes	Maximum Maintenance Interval	Maintenance Activities
Protection System Station dc supply with Valve Regulated Lead-Acid (VRLA) batteries not having monitoring attributes of Table 1-4(f).	4 Calendar Months	Verify: <ul style="list-style-type: none"> • Station dc supply voltage Inspect: <ul style="list-style-type: none"> • For unintentional grounds
	6 Calendar Months	Inspect: <ul style="list-style-type: none"> • Condition of all individual units by measuring battery cell/unit internal ohmic values.
	18 Calendar Months	Verify: <ul style="list-style-type: none"> • Float voltage of battery charger • Battery continuity • Battery terminal connection resistance • Battery intercell or unit-to-unit connection resistance Inspect: <ul style="list-style-type: none"> • Physical condition of battery rack

<p style="text-align: center;">Table 1-4(b) Component Type – Protection System Station dc Supply Using Valve-Regulated Lead-Acid (VRLA) Batteries Excluding distributed UFLS and distributed UVLS (see Table 3)</p> <p style="text-align: center;">Protection System Station dc supply used only for non-BES interrupting devices for RAS, non-distributed UFLS systems, or non-distributed UVLS systems is excluded (see Table 1-4(e)).</p>		
Component Attributes	Maximum Maintenance Interval	Maintenance Activities
	6 Calendar Months -or- 3 Calendar Years	Verify that the station battery can perform as manufactured by evaluating cell/unit measurements indicative of battery performance (e.g. internal ohmic values or float current) against the station battery baseline. -or- Verify that the station battery can perform as manufactured by conducting a performance or modified performance capacity test of the entire battery bank.

Table 1-4(c) Component Type – Protection System Station dc Supply Using Nickel-Cadmium (NiCad) Batteries Excluding distributed UFLS and distributed UVLS (see Table 3)		
Protection System Station dc supply used only for non-BES interrupting devices for RAS, non-distributed UFLS system, or non-distributed UVLS systems is excluded (see Table 1-4(e)).		
Component Attributes	Maximum Maintenance Interval	Maintenance Activities
Protection System Station dc supply Nickel-Cadmium (NiCad) batteries not having monitoring attributes of Table 1-4(f).	4 Calendar Months	Verify: <ul style="list-style-type: none"> • Station dc supply voltage Inspect: <ul style="list-style-type: none"> • Electrolyte level • For unintentional grounds
	18 Calendar Months	Verify: <ul style="list-style-type: none"> • Float voltage of battery charger • Battery continuity • Battery terminal connection resistance • Battery intercell or unit-to-unit connection resistance Inspect: <ul style="list-style-type: none"> • Cell condition of all individual battery cells. • Physical condition of battery rack

Table 1-4(c) Component Type – Protection System Station dc Supply Using Nickel-Cadmium (NiCad) Batteries Excluding distributed UFLS and distributed UVLS (see Table 3)		
Protection System Station dc supply used only for non-BES interrupting devices for RAS, non-distributed UFLS system, or non-distributed UVLS systems is excluded (see Table 1-4(e)).		
Component Attributes	Maximum Maintenance Interval	Maintenance Activities
	6 Calendar Years	Verify that the station battery can perform as manufactured by conducting a performance or modified performance capacity test of the entire battery bank.

Table 1-4(d) Component Type – Protection System Station dc Supply Using Non Battery Based Energy Storage Excluding distributed UFLS and distributed UVLS (see Table 3)		
Protection System Station dc supply used only for non-BES interrupting devices for RAS, non-distributed UFLS system, or non-distributed UVLS systems is excluded (see Table 1-4(e)).		
Component Attributes	Maximum Maintenance Interval	Maintenance Activities
Any Protection System station dc supply not using a battery and not having monitoring attributes of Table 1-4(f).	4 Calendar Months	Verify: <ul style="list-style-type: none"> • Station dc supply voltage Inspect: <ul style="list-style-type: none"> • For unintentional grounds
	18 Calendar Months	Inspect: Condition of non-battery based dc supply
	6 Calendar Years	Verify that the dc supply can perform as manufactured when ac power is not present.

Table 1-4(e) Component Type – Protection System Station dc Supply for non-BES Interrupting Devices for RAS, non-distributed UFLS, and non-distributed UVLS systems		
Component Attributes	Maximum Maintenance Interval	Maintenance Activities
Any Protection System dc supply used for tripping only non-BES interrupting devices as part of a RAS, non-distributed UFLS, or non-distributed UVLS system and not having monitoring attributes of Table 1-4(f).	When control circuits are verified (See Table 1-5)	Verify Station dc supply voltage.

Table 1-4(f) Exclusions for Protection System Station dc Supply Monitoring Devices and Systems		
Component Attributes	Maximum Maintenance Interval	Maintenance Activities
Any station dc supply with high and low voltage monitoring and alarming of the battery charger voltage to detect charger overvoltage and charger failure (See Table 2).	No periodic maintenance specified	No periodic verification of station dc supply voltage is required.
Any battery based station dc supply with electrolyte level monitoring and alarming in every cell (See Table 2).		No periodic inspection of the electrolyte level for each cell is required.
Any station dc supply with unintentional dc ground monitoring and alarming (See Table 2).		No periodic inspection of unintentional dc grounds is required.
Any station dc supply with charger float voltage monitoring and alarming to ensure correct float voltage is being applied on the station dc supply (See Table 2).		No periodic verification of float voltage of battery charger is required.
Any battery based station dc supply with monitoring and alarming of battery string continuity (See Table 2).		No periodic verification of the battery continuity is required.
Any battery based station dc supply with monitoring and alarming of the intercell and/or terminal connection detail resistance of the entire battery (See Table 2).		No periodic verification of the intercell and terminal connection resistance is required.
Any Valve Regulated Lead-Acid (VRLA) or Vented Lead-Acid (VLA) station battery with internal ohmic value or float current monitoring and alarming, and evaluating present values relative to baseline internal ohmic values for every cell/unit (See Table 2).		No periodic evaluation relative to baseline of battery cell/unit measurements indicative of battery performance is required to verify the station battery can perform as manufactured.
Any Valve Regulated Lead-Acid (VRLA) or Vented Lead-Acid (VLA) station battery with monitoring and alarming of each cell/unit internal ohmic value (See Table 2).		No periodic inspection of the condition of all individual units by measuring battery cell/unit internal ohmic values of a station VRLA or Vented Lead-Acid (VLA) battery is required.

Table 1-5 Component Type - Control Circuitry Associated With Protective Functions Excluding distributed UFLS and distributed UVLS (see Table 3), Automatic Reclosing (see Table 4), and Sudden Pressure Relaying (see Table 5) Note: Table requirements apply to all Control Circuitry Components of Protection Systems, and RAS except as noted.		
Component Attributes	Maximum Maintenance Interval	Maintenance Activities
Trip coils or actuators of circuit breakers, interrupting devices, or mitigating devices (regardless of any monitoring of the control circuitry).	6 Calendar Years	Verify that each trip coil is able to operate the circuit breaker, interrupting device, or mitigating device.
Electromechanical lockout devices which are directly in a trip path from the protective relay to the interrupting device trip coil (regardless of any monitoring of the control circuitry).	6 Calendar Years	Verify electrical operation of electromechanical lockout devices.
Unmonitored control circuitry associated with RAS. (See Table 4-2(b) for RAS which include Automatic Reclosing.)	12 Calendar Years	Verify all paths of the control circuits essential for proper operation of the RAS.
Unmonitored control circuitry associated with protective functions inclusive of all auxiliary relays.	12 Calendar Years	Verify all paths of the trip circuits inclusive of all auxiliary relays through the trip coil(s) of the circuit breakers or other interrupting devices.
Control circuitry associated with protective functions and/or RAS whose integrity is monitored and alarmed (See Table 2).	No periodic maintenance specified	None.

Table 2 – Alarming Paths and Monitoring In Tables 1-1 through 1-5, Table 3, Tables 4-1 through 4-3, and Table 5 alarm attributes used to justify extended maximum maintenance intervals and/or reduced maintenance activities are subject to the following maintenance requirements		
Component Attributes	Maximum Maintenance Interval	Maintenance Activities
Any alarm path through which alarms in Tables 1-1 through 1-5, Table 3, Tables 4-1 through 4-3, and Table 5 are conveyed from the alarm origin to the location where corrective action can be initiated, and not having all the attributes of the “Alarm Path with monitoring” category below. Alarms are reported within 24 hours of detection to a location where corrective action can be initiated.	12 Calendar Years	Verify that the alarm path conveys alarm signals to a location where corrective action can be initiated.
Alarm Path with monitoring: The location where corrective action is taken receives an alarm within 24 hours for failure of any portion of the alarming path from the alarm origin to the location where corrective action can be initiated.	No periodic maintenance specified	None.

Table 3 Maintenance Activities and Intervals for distributed UFLS and distributed UVLS Systems		
Component Attributes	Maximum Maintenance Interval	Maintenance Activities
Any unmonitored protective relay not having all the monitoring attributes of a category below.	6 Calendar Years	Verify that settings are as specified. For non-microprocessor relays: <ul style="list-style-type: none"> • Test and, if necessary calibrate. For microprocessor relays: <ul style="list-style-type: none"> • Verify operation of the relay inputs and outputs that are essential to proper functioning of the Protection System. • Verify acceptable measurement of power system input values.
Monitored microprocessor protective relay with the following: <ul style="list-style-type: none"> • Internal self-diagnosis and alarming (See Table 2). • Voltage and/or current waveform sampling three or more times per power cycle, and conversion of samples to numeric values for measurement calculations by microprocessor electronics. Alarming for power supply failure (See Table 2).	12 Calendar Years	Verify: <ul style="list-style-type: none"> • Settings are as specified. • Operation of the relay inputs and outputs that are essential to proper functioning of the Protection System. • Acceptable measurement of power system input values.
Monitored microprocessor protective relay with preceding row attributes and the following: <ul style="list-style-type: none"> • AC measurements are continuously verified by comparison to an independent ac measurement source, with alarming for excessive error (See Table 2). 	12 Calendar Years	Verify only the unmonitored relay inputs and outputs that are essential to proper functioning of the Protection System.

Table 3 Maintenance Activities and Intervals for distributed UFLS and distributed UVLS Systems		
Component Attributes	Maximum Maintenance Interval	Maintenance Activities
<ul style="list-style-type: none"> Some or all binary or status inputs and control outputs are monitored by a process that continuously demonstrates ability to perform as designed, with alarming for failure (See Table 2). Alarming for change of settings (See Table 2).		
Voltage and/or current sensing devices associated with UFLS or UVLS systems.	12 Calendar Years	Verify that current and/or voltage signal values are provided to the protective relays.
Protection System dc supply for tripping non-BES interrupting devices used only for a UFLS or UVLS system.	12 Calendar Years	Verify Protection System dc supply voltage.
Control circuitry between the UFLS or UVLS relays and electromechanical lockout and/or tripping auxiliary devices (excludes non-BES interrupting device trip coils).	12 Calendar Years	Verify the path from the relay to the lockout and/or tripping auxiliary relay (including essential supervisory logic).
Electromechanical lockout and/or tripping auxiliary devices associated only with UFLS or UVLS systems (excludes non-BES interrupting device trip coils).	12 Calendar Years	Verify electrical operation of electromechanical lockout and/or tripping auxiliary devices.
Control circuitry between the electromechanical lockout and/or tripping auxiliary devices and the non-BES interrupting devices in UFLS or UVLS systems, or between UFLS or UVLS relays (with no interposing electromechanical lockout or auxiliary device) and the non-BES interrupting devices (excludes non-BES interrupting device trip coils).	No periodic maintenance specified	None.
Trip coils of non-BES interrupting devices in UFLS or UVLS systems.	No periodic maintenance specified	None.

Table 4-1 Maintenance Activities and Intervals for Automatic Reclosing Components Component Type – Reclosing and Supervisory Relay		
Note: In cases where Components of Automatic Reclosing are common to Components listed in Table 1-1 through 1-5, the Components only need to be tested once during a distinct maintenance interval.		
Component Attributes	Maximum Maintenance Interval	Maintenance Activities
<p>Any unmonitored reclosing relay or supervisory relay not having all the monitoring attributes of a category below.</p>	<p>6 Calendar Years</p>	<p>Verify that settings are as specified.</p> <p>For non-microprocessor reclosing or supervisory relays:</p> <ul style="list-style-type: none"> • Test and, if necessary calibrate <p>For microprocessor reclosing or supervisory relays:</p> <ul style="list-style-type: none"> • Verify operation of the relay inputs and outputs that are essential to proper functioning of the Automatic Reclosing. <p>For microprocessor supervisory relays:</p> <ul style="list-style-type: none"> • Verify acceptable measurement of power system input values.
<ul style="list-style-type: none"> • Monitored microprocessor reclosing relay or supervisory relay with the following: Internal self-diagnosis and alarming (See Table 2). • Alarming for power supply failure (See Table 2). <p>For supervisory relay:</p> <ul style="list-style-type: none"> • Voltage waveform sampling three or more times per power cycle, and conversion of samples to numeric values for measurement calculations by microprocessor electronics. 	<p>12 Calendar Years</p>	<p>Verify:</p> <ul style="list-style-type: none"> • Settings are as specified. • Operation of the relay inputs and outputs that are essential to proper functioning of the Automatic Reclosing. <p>For supervisory relays:</p> <ul style="list-style-type: none"> • Verify acceptable measurement of power system input values.

Table 4-1 Maintenance Activities and Intervals for Automatic Reclosing Components Component Type – Reclosing and Supervisory Relay		
Note: In cases where Components of Automatic Reclosing are common to Components listed in Table 1-1 through 1-5, the Components only need to be tested once during a distinct maintenance interval.		
Component Attributes	Maximum Maintenance Interval	Maintenance Activities
Monitored microprocessor reclosing relay or supervisory relay with preceding row attributes and the following: <ul style="list-style-type: none"> Some or all binary or status inputs and control outputs are monitored by a process that continuously demonstrates ability to perform as designed, with alarming for failure (See Table 2). Alarming for change of settings (See Table 2). For supervisory relay: <ul style="list-style-type: none"> Ac measurements are continuously verified by comparison to an independent ac measurement source, with alarming for excessive error (See Table 2). 	12 Calendar Years	Verify only the unmonitored relay inputs and outputs that are essential to proper functioning of the Automatic Reclosing.

<p style="text-align: center;">Table 4-2(a) Maintenance Activities and Intervals for Automatic Reclosing Components Component Type – Control Circuitry Associated with Reclosing and Supervisory Relays that are NOT an Integral Part of an RAS Note: In cases where Components of Automatic Reclosing are common to Components listed in Table 1-5, the Components only need to be tested once during a distinct maintenance interval.</p>		
Component Attributes	Maximum Maintenance Interval	Maintenance Activities
Unmonitored Control circuitry associated with Automatic Reclosing that is not an integral part of an RAS.	12 Calendar Years	Verify that Automatic Reclosing, upon initiation, does not issue a premature closing command to the close circuitry.
Control circuitry associated with Automatic Reclosing that is not part of an RAS and is monitored and alarmed for conditions that would result in a premature closing command. (See Table 2)	No periodic maintenance specified	None.

Table 4-2(b)

Maintenance Activities and Intervals for Automatic Reclosing Components

Component Type – Control Circuitry Associated with Reclosing and Supervisory Relays that ARE an Integral Part of an RAS

Note: In cases where Components of Automatic Reclosing are common to Components listed in Table 1-5, the Components only need to be tested once during a distinct maintenance interval.

Component Attributes	Maximum Maintenance Interval	Maintenance Activities
Close coils or actuators of circuit breakers or similar devices that are used in conjunction with Automatic Reclosing as part of an RAS (regardless of any monitoring of the control circuitry).	6 Calendar Years	Verify that each close coil or actuator is able to operate the circuit breaker or mitigating device.
Unmonitored close control circuitry associated with Automatic Reclosing used as an integral part of an RAS.	12 Calendar Years	Verify all paths of the control circuits associated with Automatic Reclosing that are essential for proper operation of the RAS.
Control circuitry associated with Automatic Reclosing that is an integral part of an RAS whose integrity is monitored and alarmed. (See Table 2)	No periodic maintenance specified	None.

Table 4-3 Maintenance Activities and Intervals for Automatic Reclosing Components Component Type – Voltage Sensing Devices Associated with Supervisory Relays Note: In cases where Components of Automatic Reclosing are common to Components listed in Table 1-3, the Components only need to be tested once during a distinct maintenance interval.		
Component Attributes	Maximum Maintenance Interval	Maintenance Activities
Any voltage sensing devices not having monitoring attributes of the category below.	12 Calendar Years	Verify that voltage signal values are provided to the supervisory relays.
Voltage sensing devices that are connected to microprocessor supervisory relays with ac measurements that are continuously verified by comparison of sensing input value, as measured by the microprocessor relay, to an independent ac measurement source, with alarming for unacceptable error or failure. (See Table 2)	No periodic maintenance specified	None.

<p style="text-align: center;">Table 5 Maintenance Activities and Intervals for Sudden Pressure Relaying</p>		
<p style="text-align: center;">Note: In cases where Components of Sudden Pressure Relaying are common to Components listed in Table 1-5, the Components only need to be tested once during a distinct maintenance interval.</p>		
Component Attributes	Maximum Maintenance Interval	Maintenance Activities
Any fault pressure relay.	6 Calendar Years	Verify the pressure or flow sensing mechanism is operable.
Electromechanical lockout devices which are directly in a trip path from the fault pressure relay to the interrupting device trip coil (regardless of any monitoring of the control circuitry).	6 Calendar Years	Verify electrical operation of electromechanical lockout devices.
Unmonitored control circuitry associated with Sudden Pressure Relaying.	12 Calendar Years	Verify all paths of the trip circuits inclusive of all auxiliary relays through the trip coil(s) of the circuit breakers or other interrupting devices.
Control circuitry associated with Sudden Pressure Relaying whose integrity is monitored and alarmed (See Table 2).	No periodic maintenance specified	None.

PRC-005 — Attachment A

Criteria for a Performance-Based Protection System Maintenance Program

Purpose: To establish a technical basis for initial and continued use of a performance-based Protection System Maintenance Program (PSMP).

To establish the technical justification for the initial use of a performance-based PSMP:

1. Develop a list with a description of Components included in each designated Segment, with a minimum Segment population of 60 Components.
2. Maintain the Components in each Segment according to the time-based maximum allowable intervals established in Tables 1-1 through 1-5, Table 3, Tables 4-1 through 4-3, and Table 5 until results of maintenance activities for the Segment are available for a minimum of 30 individual Components of the Segment.
3. Document the maintenance program activities and results for each Segment, including maintenance dates and Countable Events for each included Component.
4. Analyze the maintenance program activities and results for each Segment to determine the overall performance of the Segment and develop maintenance intervals.
5. Determine the maximum allowable maintenance interval for each Segment such that the Segment experiences Countable Events on no more than 4% of the Components within the Segment, for the greater of either the last 30 Components maintained or all Components maintained in the previous year.

To maintain the technical justification for the ongoing use of a performance-based PSMP:

1. At least annually, update the list of Components and Segments and/or description if any changes occur within the Segment.
2. Perform maintenance on the greater of 5% of the Components (addressed in the performance based PSMP) in each Segment or 3 individual Components within the Segment in each year.
3. For the prior year, analyze the maintenance program activities and results for each Segment to determine the overall performance of the Segment.
4. Using the prior year's data, determine the maximum allowable maintenance interval for each Segment such that the Segment experiences Countable Events on no more than 4% of the Components within the Segment, for the greater of either the last 30 Components maintained or all Components maintained in the previous year.

If the Components in a Segment maintained through a performance-based PSMP experience 4% or more Countable Events, develop, document, and implement an action plan to reduce the Countable Events to less than 4% of the Segment population within 3 years.

Rationale:

During development of this standard, text boxes were embedded within the standard to explain the rationale for various parts of the standard. Upon BOT approval, the text from the rationale text boxes was moved to this section.

Rationale for revisions to Automatic Reclosing:

To address directives from FERC Order No. 803 addressing Automatic Reclosing, the definition for Automatic Reclosing was revised to add supervisory relays, the associated voltage sensing devices, and the associated control circuitry.

Rationale for revisions to Component Type:

With the revision of the definition of Automatic Reclosing, there are four specific elements of this definition, rather than two as stated in the prior version.

Redline Version

PRC-005-6 to PRC-005-4

A. Introduction

1. **Title:** Protection System, Automatic Reclosing, and Sudden Pressure Relaying Maintenance
2. **Number:** PRC-005-46
3. **Purpose:** To document and implement programs for the maintenance of all Protection Systems, Automatic Reclosing, and Sudden Pressure Relaying affecting the reliability of the Bulk Electric System (BES) so that they are kept in working order.
4. **Applicability:**
 - 4.1. **Functional Entities:**
 - 4.1.1 Transmission Owner
 - 4.1.2 Generator Owner
 - 4.1.3 Distribution Provider
 - 4.2. **Facilities:**
 - 4.2.1 Protection Systems and Sudden Pressure Relaying that are installed for the purpose of detecting Faults on BES Elements (lines, buses, transformers, etc.)
 - 4.2.2 Protection Systems used for underfrequency load-shedding systems installed per ERO underfrequency load-shedding requirements.
 - 4.2.3 Protection Systems used for undervoltage load-shedding systems installed to prevent system voltage collapse or voltage instability for BES reliability.
 - 4.2.4 Protection Systems installed as a Remedial Action Scheme (RAS) for BES reliability.
 - 4.2.5 Protection Systems and Sudden Pressure Relaying for generator Facilities that are part of the BES, including-except for generators identified through Inclusion I4 of the BES definition, including:
 - 4.2.5.1 Protection Systems that act to trip the generator either directly or via lockout or auxiliary tripping relays.
 - 4.2.5.2 Protection Systems and Sudden Pressure Relaying for generator step-up transformers for generators that are part of the BES.
 - ~~4.2.5.3 Protection Systems and Sudden Pressure Relaying for transformers connecting aggregated generation, where the aggregated generation is part of the BES (e.g., transformers connecting facilities such as wind farms to the BES).~~

4.2.5.4.2.5.3 -Protection Systems and Sudden Pressure Relaying for station service or excitation transformers connected to the generator bus of generators which are part of the BES, that act to trip the generator either directly or via lockout or tripping auxiliary relays.

4.2.6 Protection Systems and Sudden Pressure Relaying for the following BES generator Facilities for dispersed power producing resources identified through Inclusion I4 of the BES definition:

4.2.6.1 Protection Systems and Sudden Pressure Relaying for Facilities used in aggregating dispersed BES generation from the point where those resources aggregate to greater than 75 MVA to a common point of connection at 100kV or above.

4.2.6.4.2.7 Automatic Reclosing¹, including:

4.2.6.14.2.7.1 Automatic Reclosing applied on the terminals of Elements connected to the BES bus located at generating plant substations where the total installed gross generating plant capacity is greater than the gross capacity of the largest BES generating unit within the Balancing Authority Area or, if a member of a Reserve Sharing Group, the largest generating unit within the Reserve Sharing Group.²

4.2.6.24.2.7.2 Automatic Reclosing applied on the terminals of all BES Elements at substations one bus away from generating plants specified in Section 4.2.6.7.1 when the substation is less than 10 circuit-miles from the generating plant substation.

4.2.6.34.2.7.3 Automatic Reclosing applied as an integral part of an RAS specified in Section 4.2.4.

5. **Effective Date:** See [the Implementation Plan for this standard.](#)

6. **Definitions Used in this Standard:**

Automatic Reclosing – Includes the following Components:

¹ Automatic Reclosing addressed in Section 4.2.6.7.1 and 4.2.6.7.2 may be excluded if the equipment owner can demonstrate that a close-in three-phase fault present for twice the normal clearing time (capturing a minimum trip-close-trip time delay) does not result in a total loss of gross generation in the Interconnection exceeding the gross capacity of the largest relevant BES generating unit where the Automatic Reclosing is applied.

² The largest BES generating unit within the Balancing Authority Area or the largest generating unit within the Reserve Sharing Group, as applicable, is subject to change. As a result of such a change, the Automatic Reclosing Components subject to the standard could change effective on the date of such change.

- Reclosing relay
- Supervisory relay(s) or function(s) – relay(s) or function(s) that perform voltage and/or sync check functions that enable or disable operation of the reclosing relay
- Voltage sensing devices associated with the supervisory relay(s) or function(s)
- Control circuitry associated with the reclosing relay- or supervisory relay(s) or function(s)

Sudden Pressure Relaying – A system that trips an interrupting device(s) to isolate the equipment it is monitoring and includes the following Components:

- Fault pressure relay – a mechanical relay or device that detects rapid changes in gas pressure, oil pressure, or oil flow that are indicative of Faults within liquid-filled, wire-wound equipment
- Control circuitry associated with a fault pressure relay

Unresolved Maintenance Issue – A deficiency identified during a maintenance activity that causes the Component to not meet the intended performance, cannot be corrected during the maintenance interval, and requires follow-up corrective action.

Segment – Components of a consistent design standard, or a particular model or type from a single manufacturer that typically share other common elements. Consistent performance is expected across the entire population of a Segment. A Segment must contain at least sixty (60) individual Components.

Component Type –

- Any one of the five specific elements of a Protection System-~~7~~
- Any one of the ~~two~~four specific elements of Automatic Reclosing-~~7~~
- Any one of the two specific elements of Sudden Pressure Relaying-~~7~~

Component – Any individual discrete piece of equipment included in a Protection System, Automatic Reclosing, or Sudden Pressure Relaying.

Countable Event – A failure of a Component requiring repair or replacement, any condition discovered during the maintenance activities in Tables 1-1 through 1-5, Table 3, Tables 4-1 through 4-~~23~~, and Table 5, which requires corrective action or a Protection System Misoperation attributed to hardware failure or calibration failure.

Misoperations due to product design errors, software errors, relay settings different from specified settings, Protection System Component, Automatic Reclosing, or Sudden Pressure Relaying configuration or application errors are not included in Countable Events.

B. Requirements and Measures

- R1.** Each Transmission Owner, Generator Owner, and Distribution Provider shall establish a Protection System Maintenance Program (PSMP) for its Protection Systems, Automatic Reclosing, and Sudden Pressure Relaying identified in Section 4.2, Facilities. *[Violation Risk Factor: Medium] [Time Horizon: Operations Planning]*

The PSMP shall:

- 1.1.** Identify which maintenance method (time-based, performance-based per PRC-005 Attachment A, or a combination) is used to address each Protection System, Automatic Reclosing, and Sudden Pressure Relaying Component Type. All batteries associated with the station dc supply Component Type of a Protection System shall be included in a time-based program as described in Table 1-4 and Table 3.
- 1.2.** Include the applicable monitored Component attributes applied to each Protection System, Automatic Reclosing, and Sudden Pressure Relaying Component Type consistent with the maintenance intervals specified in Tables 1-1 through 1-5, Table 2, Table 3, Table 4-1 through 4-23, and Table 5 where monitoring is used to extend the maintenance intervals beyond those specified for unmonitored Protection System, Automatic Reclosing, and Sudden Pressure Relaying Components.
- M1.** Each Transmission Owner, Generator Owner and Distribution Provider shall have a documented ~~Protection System Maintenance Program~~ PSMP in accordance with Requirement R1.

For each Protection System, Automatic Reclosing, and Sudden Pressure Relaying Component Type, the documentation shall include the type of maintenance method applied (time-based, performance-based, or a combination of these maintenance methods), and shall include all batteries associated with the station dc supply Component Types in a time-based program as described in Table 1-4 and Table 3. (Part 1.1)

For Component Types that use monitoring to extend the maintenance intervals, the responsible entity(s) shall have evidence for each Protection System, Automatic Reclosing, and Sudden Pressure Relaying Component Type (such as manufacturer's specifications or engineering drawings) of the appropriate monitored Component attributes as specified in Tables 1-1 through 1-5, Table 2, Table 3, Table 4-1 through 4-23, and Table 5. (Part 1.2)

- R2.** Each Transmission Owner, Generator Owner, and Distribution Provider that uses performance-based maintenance intervals in its PSMP shall follow the procedure established in PRC-005 Attachment A to establish and maintain its performance-based intervals. *[Violation Risk Factor: Medium] [Time Horizon: Operations Planning]*
- M2.** Each Transmission Owner, Generator Owner, and Distribution Provider that uses performance-based maintenance intervals shall have evidence that its current

performance-based maintenance program(s) is in accordance with Requirement R2, which may include, but is not limited to, Component lists, dated maintenance records, and dated analysis records and results.

- R3.** Each Transmission Owner, Generator Owner, and Distribution Provider that utilizes time-based maintenance program(s) shall maintain its Protection System, Automatic Reclosing, and Sudden Pressure Relaying Components that are included within the time-based maintenance program in accordance with the minimum maintenance activities and maximum maintenance intervals prescribed within Tables 1-1 through 1-5, Table 2, Table 3, Table 4-1 through 4-23, and Table 5. *[Violation Risk Factor: High] [Time Horizon: Operations Planning]*
- M3.** Each Transmission Owner, Generator Owner, and Distribution Provider that utilizes time-based maintenance program(s) shall have evidence that it has maintained its Protection System, Automatic Reclosing, and Sudden Pressure Relaying Components included within its time-based program in accordance with Requirement R3. The evidence may include, but is not limited to, dated maintenance records, dated maintenance summaries, dated check-off lists, dated inspection records, or dated work orders.
- R4.** Each Transmission Owner, Generator Owner, and Distribution Provider that utilizes performance-based maintenance program(s) in accordance with Requirement R2 shall implement and follow its PSMP for its Protection System, Automatic Reclosing, and Sudden Pressure Relaying Components that are included within the performance-based program(s). *[Violation Risk Factor: High] [Time Horizon: Operations Planning]*
- M4.** Each Transmission Owner, Generator Owner, and Distribution Provider that utilizes performance-based maintenance intervals in accordance with Requirement R2 shall have evidence that it has implemented the ~~Protection System Maintenance Program~~ PSMP for the Protection System, Automatic Reclosing, and Sudden Pressure Relaying Components included in its performance-based program in accordance with Requirement R4. The evidence may include, but is not limited to, dated maintenance records, dated maintenance summaries, dated check-off lists, dated inspection records, or dated work orders.
- R5.** Each Transmission Owner, Generator Owner, and Distribution Provider shall demonstrate efforts to correct identified Unresolved Maintenance Issues. *[Violation Risk Factor: Medium] [Time Horizon: Operations Planning]*
- M5.** Each Transmission Owner, Generator Owner, and Distribution Provider shall have evidence that it has undertaken efforts to correct identified Unresolved Maintenance Issues in accordance with Requirement R5. The evidence may include, but is not limited to, work orders, replacement Component orders, invoices, project schedules with completed milestones, return material authorizations (RMAs) or purchase orders.

C. Compliance

1. Compliance Monitoring Process

1.1. Compliance Enforcement Authority

As defined in the NERC Rules of Procedure, “Compliance Enforcement Authority” means NERC or the Regional Entity in their respective roles of monitoring and enforcing compliance with the NERC Reliability Standards.

1.2. Evidence Retention

The following evidence retention periods identify the period of time an entity is required to retain specific evidence to demonstrate compliance. For instances where the evidence retention period specified below is shorter than the time since the last audit, the Compliance Enforcement Authority may ask an entity to provide other evidence to show that it was compliant for the full time period since the last audit.

The Transmission Owner, Generator Owner, and Distribution Provider shall each keep data or evidence to show compliance as identified below unless directed by its Compliance Enforcement Authority to retain specific evidence for a longer period of time as part of an investigation.

For Requirement R1, the Transmission Owner, Generator Owner, and Distribution Provider shall each keep its current dated ~~Protection System Maintenance Program~~ PSMP, as well as any superseded versions since the preceding compliance audit, including the documentation that specifies the type of maintenance program applied for each Protection System, Automatic Reclosing, or Sudden Pressure Relaying Component Type.

For Requirement R2, Requirement R3, and Requirement R4, in cases where the interval of the maintenance activity is longer than the audit cycle, the Transmission Owner, Generator Owner, and Distribution Provider shall each keep documentation of the most recent performance of that maintenance activity for the Protection System, Automatic Reclosing, or Sudden Pressure Relaying Component. In cases where the interval of the maintenance activity is shorter than the audit cycle, documentation of all performances (in accordance with the tables) of that maintenance activity for the Protection System, Automatic Reclosing, or Sudden Pressure Relaying Component since the previous scheduled audit date shall be retained.

For Requirement R5 the Transmission Owner, Generator Owner, and Distribution Provider shall each keep documentation of Unresolved Maintenance Issues identified by the entity since the last audit, including all that were resolved since the last audit.

~~The Compliance Enforcement Authority shall keep the last audit records and all requested and submitted subsequent audit records.~~

1.3. Compliance Monitoring and Assessment Processes:

Compliance Audits

Self-Certifications

Spot Checking

Compliance-~~Violation~~ Investigations

Self-Reporting

Complaints

1.4. Additional Compliance Information

None

Table of Compliance Elements

Requirement Number	Lower VSL	Moderate VSL	High VSL	Severe VSL
R1	The entity’s PSMP failed to specify whether one Component Type is being addressed by time-based or performance-based maintenance, or a combination of both (Part 1.1).	The entity’s PSMP failed to specify whether two Component Types are being addressed by time-based or performance-based maintenance, or a combination of both (Part 1.1).	<p>The entity’s PSMP failed to specify whether three Component Types are being addressed by time-based or performance-based maintenance, or a combination of both. (Part 1.1).</p> <p>OR</p> <p>The entity’s PSMP failed to include the applicable monitoring attributes applied to each Component Type consistent with the maintenance intervals specified in Tables 1-1 through 1-5, Table 2, Table 3, Tables 4-1 through 4-23, and Table 5 where monitoring is used to extend the maintenance intervals beyond those specified for unmonitored Components (Part 1.2).</p>	<p>The entity failed to establish a PSMP.</p> <p>OR</p> <p>The entity’s PSMP failed to specify whether four or more Component Types are being addressed by time-based or performance-based maintenance, or a combination of both (Part 1.1).</p> <p>OR</p> <p>The entity’s PSMP failed to include applicable station batteries in a time-based program (Part 1.1).</p>
R2	The entity uses performance-based maintenance intervals in its PSMP but failed to reduce Countable Events to no more than 4% within three years.	NA	The entity uses performance-based maintenance intervals in its PSMP but failed to reduce Countable Events to no more than 4% within four years.	<p>The entity uses performance-based maintenance intervals in its PSMP but:</p> <ol style="list-style-type: none"> 1) Failed to establish the technical justification described within Requirement R2 for the initial use of the performance-based PSMP <p>OR</p> <ol style="list-style-type: none"> 2) Failed to reduce Countable Events to no more than 4% within five years <p>OR</p>

Requirement Number	Lower VSL	Moderate VSL	High VSL	Severe VSL
				3) Maintained a Segment with less than 60 Components OR 4) Failed to: <ul style="list-style-type: none"> • Annually update the list of Components, OR • Annually perform maintenance on the greater of 5% of the Segment population or 3 Components, OR • Annually analyze the program activities and results for each Segment.
R3	For Components included within a time-based maintenance program, the entity failed to maintain 5% or less of the total Components included within a specific Component Type in accordance with the minimum maintenance activities and maximum maintenance intervals prescribed within Tables 1-1 through 1-5, Table 2, Table 3, Tables 4-1 through 4-23, and Table 5.	For Components included within a time-based maintenance program, the entity failed to maintain more than 5% but 10% or less of the total Components included within a specific Component Type in accordance with the minimum maintenance activities and maximum maintenance intervals prescribed within Tables 1-1 through 1-5, Table 2, Table 3, Tables 4-1 through 4-23, and Table 5.	For Components included within a time-based maintenance program, the entity failed to maintain more than 10% but 15% or less of the total Components included within a specific Component Type in accordance with the minimum maintenance activities and maximum maintenance intervals prescribed within Tables 1-1 through 1-5, Table 2, Table 3, Tables 4-1 through 4-23, and Table 5.	For Components included within a time-based maintenance program, the entity failed to maintain more than 15% of the total Components included within a specific Component Type in accordance with the minimum maintenance activities and maximum maintenance intervals prescribed within Tables 1-1 through 1-5, Table 2, Table 3, Tables 4-1 through 4-23, and Table 5.

Requirement Number	Lower VSL	Moderate VSL	High VSL	Severe VSL
R4	For Components included within a performance-based maintenance program, the entity failed to maintain 5% or less of the annual scheduled maintenance for a specific Component Type in accordance with their performance-based PSMP.	For Components included within a performance-based maintenance program, the entity failed to maintain more than 5% but 10% or less of the annual scheduled maintenance for a specific Component Type in accordance with their performance-based PSMP.	For Components included within a performance-based maintenance program, the entity failed to maintain more than 10% but 15% or less of the annual scheduled maintenance for a specific Component Type in accordance with their performance-based PSMP.	For Components included within a performance-based maintenance program, the entity failed to maintain more than 15% of the annual scheduled maintenance for a specific Component Type in accordance with their performance-based PSMP.
R5	The entity failed to undertake efforts to correct 5 or fewer identified Unresolved Maintenance Issues.	The entity failed to undertake efforts to correct greater than 5 but less than or equal to 10 identified Unresolved Maintenance Issues.	The entity failed to undertake efforts to correct greater than 10 but less than or equal to 15 identified Unresolved Maintenance Issues.	The entity failed to undertake efforts to correct greater than 15 identified Unresolved Maintenance Issues.

D. Regional Variances

None.

E. Interpretations

None.

Supplemental Reference Documents

The following documents present a detailed discussion about determination of maintenance intervals and other useful information regarding establishment of a maintenance program.

1. *Supplementary Reference and FAQ - PRC-005-46 Protection System Maintenance*, Protection System Maintenance and Testing Standard Drafting Team ([April 2014](#)[July 2015](#))
2. *Considerations for Maintenance and Testing of Auto-reclosing Schemes*, NERC System Analysis and Modeling Subcommittee, and NERC System Protection and Control Subcommittee (November 2012)
3. *Sudden Pressure Relays and Other Devices that Respond to Non-Electrical Quantities – SPCS Input for Standard Development in Response to FERC Order No. 758*, NERC System Protection and Control Subcommittee (December 2013)
4. *Sudden Pressure Relays and Other Devices that Respond to Non-Electrical Quantities – Supplemental Information to Support Project 2007-17.3: Protection System Maintenance and Testing* (October 31, 2014)

Version History

Version	Date	Action	Change Tracking
0	February 8, 2005	Adopted by NERC Board of Trustees	New
1	February 7, 2006	Adopted by NERC Board of Trustees	<ol style="list-style-type: none"> 1. Changed incorrect use of certain hyphens (-) to “en dash” (–) and “em dash (—).” 2. Added “periods” to items where appropriate. Changed “Timeframe” to “Time Frame” in item D, 1.2.
<u>1</u>	<u>March 16, 2007</u>	<u>PRC-005-1 Approved by FERC.</u> <u>Docket No. RM06-16-000</u>	

Version	Date	Action	Change Tracking
1a	February 17, 2011	Adopted by NERC Board of Trustees	Added Appendix 1 - Interpretation regarding applicability of standard to protection of radially connected transformers developed in Project 2009-17
<u>1a</u>	<u>September 26, 2011</u>	<u>Approved by FERC. Docket No. RD11-5-000</u>	
1b	November 5, 2009	Adopted by NERC Board of Trustees	Interpretation of R1, R1.1, and R1.2 developed by Project 2009-10
1b	February 3, 2012	FERC Order approving revised definition of “Protection System”	Per footnote 8 of FERC’s order, the definition of “Protection System” supersedes interpretation “b” of PRC-005-1b upon the effective date of the modified definition (i.e., April 1, 2013) <i>See N. Amer. Elec. Reliability Corp., 138 FERC ¶ 61,095 (February 3, 2012).</i>
<u>1b</u>	<u>February 3, 2012</u>	<u>PRC-005-1b Approved by FERC. Docket No. RM10-5-000</u>	
1.1b	May 9, 2012	Adopted by NERC Board of Trustees	Errata change developed by Project 2010-07, clarified inclusion of generator interconnection Facility in Generator Owner’s responsibility
<u>1.1b</u>	<u>September 19, 2013</u>	<u>PRC-005-1.1b Approved by FERC. Docket No. RM12-16-000</u>	
2	November 7, 2012	Adopted by NERC Board of Trustees	Project 2007-17 - Complete revision, absorbing maintenance requirements from PRC-005-1.1b, PRC-008-0, PRC-011-0, PRC-017-0

Version	Date	Action	Change Tracking
2	October 17, 2013	Approved by NERC Standards Committee	Errata Change: The Standards Committee approved an errata change to the implementation plan for PRC-005-2 to add the phrase “or as otherwise made effective pursuant to the laws applicable to such ERO governmental authorities;” to the second sentence under the “Retirement of Existing Standards” section. (no change to standard version number)
<u>2</u>	<u>December 19, 2013</u>	<u>PRC-005-2 Approved by FERC. Docket No. RM13-7-000</u>	
2	March 7, 2014	Adopted by NERC Board of Trustees	Modified R1 VSL in response to FERC directive (no change to standard version number)
2(i)	November 13, 2014	Adopted by NERC Board of Trustees	Applicability section revised by Project 2014-01 to clarify application of Requirements to BES dispersed power producing resources
<u>2(i)</u>	<u>May 29, 2015</u>	<u>PRC-005-2(i) Approved by FERC. Docket No. RD15-3-000</u>	
2(ii)	November 13, 2014	Adopted by NERC Board of Trustees	Replaced references to Special Protection System and SPS with Remedial Action Scheme and RAS
3	November 7, 2013	Adopted by the NERC Board of Trustees	Revised to address the FERC directive in Order No. 758 to include Automatic Reclosing in maintenance programs

Version	Date	Action	Change Tracking
3	February 12, 2014	Approved by NERC Standards Committee	Errata Change: The Standards Committee approved errata changes to correct capitalization of certain defined terms within the definitions of “Unresolved Maintenance Issue” and “Protection System Maintenance Program”. The changes will be reflected in the definitions section of PRC-005-3 for “Unresolved Maintenance Issue” and in the NERC Glossary of Terms for “Protection System Maintenance Program”. (no change to standard version number)
3	March 7, 2014	Adopted by NERC Board of Trustees	Modified R1 VSL in response to FERC directive (no change to standard version number)
<u>3</u>	<u>January 22, 2015</u>	<u>PRC-005-3 Approved by FERC. Docket No. RM14-8-000</u>	
3(i)	November 13, 2014	Adopted by NERC Board of Trustees	Applicability section revised by Project 2014-01 to clarify application of Requirements to BES dispersed power producing resources
<u>3(i)</u>	<u>May 29, 2015</u>	<u>PRC-005-3(i) Approved by FERC. Docket No. RD15-3-000</u>	
3(ii)	November 13, 2014	Adopted by NERC Board of Trustees	Replaced references to Special Protection System and SPS with Remedial Action Scheme and RAS
4	November 13, 2014	Adopted by NERC Board of Trustees	Added Sudden Pressure Relaying in response to FERC Order No. 758

Version	Date	Action	Change Tracking
4	September <u>Sept</u> 17, 2015	FERC approved PRC-005-4-Order No. 813. <u>Approved by FERC.</u> Docket No. RM15-9-000	
<u>5</u>	<u>May 7, 2015</u>	<u>Adopted by NERC Board of Trustees</u>	<u>Applicability section revised by Project 2014-01 to clarify application of Requirements to BES dispersed power producing resources.</u>
<u>6</u>	<u>November 5, 2015</u>	<u>Adopted by NERC Board of Trustees</u>	<u>Revised to add supervisory relays, the voltage sensing devices, and the associated control circuitry to Automatic Reclosing in accordance with the directives in FERC Order 803.</u>

Table 1-1 Component Type - Protective Relay Excluding distributed UFLS and distributed UVLS (see Table 3)		
Component Attributes	Maximum Maintenance Interval ³	Maintenance Activities
Any unmonitored protective relay not having all the monitoring attributes of a category below.	6 Calendar Years	For all unmonitored relays: <ul style="list-style-type: none"> • Verify that settings are as specified For non-microprocessor relays: <ul style="list-style-type: none"> • Test and, if necessary calibrate For microprocessor relays: <ul style="list-style-type: none"> • Verify operation of the relay inputs and outputs that are essential to proper functioning of the Protection System. • Verify acceptable measurement of power system input values.
Monitored microprocessor protective relay with the following: <ul style="list-style-type: none"> • Internal self-diagnosis and alarming (see Table 2). • Voltage and/or current waveform sampling three or more times per power cycle, and conversion of samples to numeric values for measurement calculations by microprocessor electronics. • Alarming for power supply failure (see Table 2). 	12 Calendar Years	Verify: <ul style="list-style-type: none"> • Settings are as specified. • Operation of the relay inputs and outputs that are essential to proper functioning of the Protection System. • Acceptable measurement of power system input values.

³ For the tables in this standard, a calendar year starts on the first day of a new year (January 1) after a maintenance activity has been completed. For the tables in this standard, a calendar month starts on the first day of the first month after a maintenance activity has been completed.

Table 1-1 Component Type - Protective Relay Excluding distributed UFLS and distributed UVLS (see Table 3)		
Component Attributes	Maximum Maintenance Interval ³	Maintenance Activities
Monitored microprocessor protective relay with preceding row attributes and the following: <ul style="list-style-type: none"> • Ac measurements are continuously verified by comparison to an independent ac measurement source, with alarming for excessive error (See Table 2). • Some or all binary or status inputs and control outputs are monitored by a process that continuously demonstrates ability to perform as designed, with alarming for failure (See Table 2). • Alarming for change of settings (See Table 2). 	12 Calendar Years	Verify only the unmonitored relay inputs and outputs that are essential to proper functioning of the Protection System.

Table 1-2 Component Type - Communications Systems Excluding distributed UFLS and distributed UVLS (see Table 3)		
Component Attributes	Maximum Maintenance Interval	Maintenance Activities
Any unmonitored communications system necessary for correct operation of protective functions, and not having all the monitoring attributes of a category below.	4 Calendar Months	Verify that the communications system is functional.
	6 Calendar Years	Verify that the communications system meets performance criteria pertinent to the communications technology applied (e.g. signal level, reflected power, or data error rate). Verify operation of communications system inputs and outputs that are essential to proper functioning of the Protection System.
Any communications system with continuous monitoring or periodic automated testing for the presence of the channel function, and alarming for loss of function (See Table 2).	12 Calendar Years	Verify that the communications system meets performance criteria pertinent to the communications technology applied (e.g. signal level, reflected power, or data error rate). Verify operation of communications system inputs and outputs that are essential to proper functioning of the Protection System.
Any communications system with all of the following: <ul style="list-style-type: none"> • Continuous monitoring or periodic automated testing for the performance of the channel using criteria pertinent to the communications technology applied (e.g. signal level, reflected power, or data error rate, and alarming for excessive performance degradation). (See Table 2) • Some or all binary or status inputs and control outputs are monitored by a process that continuously demonstrates ability to perform as designed, with alarming for failure (See Table 2). 	12 Calendar Years	Verify only the unmonitored communications system inputs and outputs that are essential to proper functioning of the Protection System

Table 1-3 Component Type - Voltage and Current Sensing Devices Providing Inputs to Protective Relays Excluding distributed UFLS and distributed UVLS (see Table 3)		
Component Attributes	Maximum Maintenance Interval	Maintenance Activities
Any voltage and current sensing devices not having monitoring attributes of the category below.	12 Calendar Years	Verify that current and voltage signal values are provided to the protective relays.
Voltage and Current Sensing devices connected to microprocessor relays with <u>ACac</u> measurements <u>that</u> are continuously verified by comparison of sensing input value, as measured by the microprocessor relay, to an independent ac measurement source, with alarming for unacceptable error or failure (see Table 2).	No periodic maintenance specified	None.

Table 1-4(a) Component Type – Protection System Station dc Supply Using Vented Lead-Acid (VLA) Batteries Excluding distributed UFLS and distributed UVLS (see Table 3)		
Protection System Station dc supply used only for non-BES interrupting devices for RAS, non-distributed UFLS systems, or non-distributed UVLS systems is excluded (see Table 1-4(e)).		
Component Attributes	Maximum Maintenance Interval	Maintenance Activities
Protection System Station dc supply using Vented Lead-Acid (VLA) batteries not having monitoring attributes of Table 1-4(f).	4 Calendar Months	Verify: <ul style="list-style-type: none"> • Station dc supply voltage Inspect: <ul style="list-style-type: none"> • Electrolyte level • For unintentional grounds
	18 Calendar Months	Verify: <ul style="list-style-type: none"> • Float voltage of battery charger • Battery continuity • Battery terminal connection resistance • Battery intercell or unit-to-unit connection resistance Inspect: <ul style="list-style-type: none"> • Cell condition of all individual battery cells where cells are visible – or measure battery cell/unit internal ohmic values where the cells are not visible • Physical condition of battery rack

<p style="text-align: center;">Table 1-4(a) Component Type – Protection System Station dc Supply Using Vented Lead-Acid (VLA) Batteries Excluding distributed UFLS and distributed UVLS (see Table 3)</p> <p style="text-align: center;">Protection System Station dc supply used only for non-BES interrupting devices for RAS, non-distributed UFLS systems, or non-distributed UVLS systems is excluded (see Table 1-4(e)).</p>		
Component Attributes	Maximum Maintenance Interval	Maintenance Activities
	18 Calendar Months -or- 6 Calendar Years	Verify that the station battery can perform as manufactured by evaluating cell/unit measurements indicative of battery performance (e.g. internal ohmic values or float current) against the station battery baseline. -or- Verify that the station battery can perform as manufactured by conducting a performance or modified performance capacity test of the entire battery bank.

Table 1-4(b) Component Type – Protection System Station dc Supply Using Valve-Regulated Lead-Acid (VRLA) Batteries Excluding distributed UFLS and distributed UVLS (see Table 3)		
Protection System Station dc supply used only for non-BES interrupting devices for RAS, non-distributed UFLS systems, or non-distributed UVLS systems is excluded (see Table 1-4(e)).		
Component Attributes	Maximum Maintenance Interval	Maintenance Activities
Protection System Station dc supply with Valve Regulated Lead-Acid (VRLA) batteries not having monitoring attributes of Table 1-4(f).	4 Calendar Months	Verify: <ul style="list-style-type: none"> • Station dc supply voltage Inspect: <ul style="list-style-type: none"> • For unintentional grounds
	6 Calendar Months	Inspect: <ul style="list-style-type: none"> • Condition of all individual units by measuring battery cell/unit internal ohmic values.
	18 Calendar Months	Verify: <ul style="list-style-type: none"> • Float voltage of battery charger • Battery continuity • Battery terminal connection resistance • Battery intercell or unit-to-unit connection resistance Inspect: <ul style="list-style-type: none"> • Physical condition of battery rack

<p align="center">Table 1-4(b)</p> <p align="center">Component Type – Protection System Station dc Supply Using Valve-Regulated Lead-Acid (VRLA) Batteries</p> <p align="center">Excluding distributed UFLS and distributed UVLS (see Table 3)</p> <p align="center">Protection System Station dc supply used only for non-BES interrupting devices for RAS, non-distributed UFLS systems, or non-distributed UVLS systems is excluded (see Table 1-4(e)).</p>		
Component Attributes	Maximum Maintenance Interval	Maintenance Activities
	6 Calendar Months -or- 3 Calendar Years	Verify that the station battery can perform as manufactured by evaluating cell/unit measurements indicative of battery performance (e.g. internal ohmic values or float current) against the station battery baseline. -or- Verify that the station battery can perform as manufactured by conducting a performance or modified performance capacity test of the entire battery bank.

Table 1-4(c) Component Type – Protection System Station dc Supply Using Nickel-Cadmium (NiCad) Batteries Excluding distributed UFLS and distributed UVLS (see Table 3)		
Protection System Station dc supply used only for non-BES interrupting devices for RAS, non-distributed UFLS system, or non-distributed UVLS systems is excluded (see Table 1-4(e)).		
Component Attributes	Maximum Maintenance Interval	Maintenance Activities
Protection System Station dc supply Nickel-Cadmium (NiCad) batteries not having monitoring attributes of Table 1-4(f).	4 Calendar Months	Verify: <ul style="list-style-type: none"> • Station dc supply voltage Inspect: <ul style="list-style-type: none"> • Electrolyte level • For unintentional grounds
	18 Calendar Months	Verify: <ul style="list-style-type: none"> • Float voltage of battery charger • Battery continuity • Battery terminal connection resistance • Battery intercell or unit-to-unit connection resistance Inspect: <ul style="list-style-type: none"> • Cell condition of all individual battery cells. • Physical condition of battery rack

Table 1-4(c)

Component Type – Protection System Station dc Supply Using Nickel-Cadmium (NiCad) Batteries
 Excluding distributed UFLS and distributed UVLS (see Table 3)

Protection System Station dc supply used only for non-BES interrupting devices for RAS, non-distributed UFLS system, or non-distributed UVLS systems is excluded (see Table 1-4(e)).

Component Attributes	Maximum Maintenance Interval	Maintenance Activities
	6 Calendar Years	Verify that the station battery can perform as manufactured by conducting a performance or modified performance capacity test of the entire battery bank.

Table 1-4(d) Component Type – Protection System Station dc Supply Using Non Battery Based Energy Storage Excluding distributed UFLS and distributed UVLS (see Table 3)		
Protection System Station dc supply used only for non-BES interrupting devices for RAS, non-distributed UFLS system, or non-distributed UVLS systems is excluded (see Table 1-4(e)).		
Component Attributes	Maximum Maintenance Interval	Maintenance Activities
Any Protection System station dc supply not using a battery and not having monitoring attributes of Table 1-4(f).	4 Calendar Months	Verify: <ul style="list-style-type: none"> • Station dc supply voltage Inspect: <ul style="list-style-type: none"> • For unintentional grounds
	18 Calendar Months	Inspect: Condition of non-battery based dc supply
	6 Calendar Years	Verify that the dc supply can perform as manufactured when ac power is not present.

Table 1-4(e) Component Type – Protection System Station dc Supply for non-BES Interrupting Devices for RAS, non-distributed UFLS, and non-distributed UVLS systems		
Component Attributes	Maximum Maintenance Interval	Maintenance Activities
Any Protection System dc supply used for tripping only non-BES interrupting devices as part of a RAS, non-distributed UFLS, or non-distributed UVLS system and not having monitoring attributes of Table 1-4(f).	When control circuits are verified (See Table 1-5)	Verify Station dc supply voltage.

Table 1-4(f) Exclusions for Protection System Station dc Supply Monitoring Devices and Systems		
Component Attributes	Maximum Maintenance Interval	Maintenance Activities
Any station dc supply with high and low voltage monitoring and alarming of the battery charger voltage to detect charger overvoltage and charger failure (See Table 2).	No periodic maintenance specified	No periodic verification of station dc supply voltage is required.
Any battery based station dc supply with electrolyte level monitoring and alarming in every cell (See Table 2).		No periodic inspection of the electrolyte level for each cell is required.
Any station dc supply with unintentional dc ground monitoring and alarming (See Table 2).		No periodic inspection of unintentional dc grounds is required.
Any station dc supply with charger float voltage monitoring and alarming to ensure correct float voltage is being applied on the station dc supply (See Table 2).		No periodic verification of float voltage of battery charger is required.
Any battery based station dc supply with monitoring and alarming of battery string continuity (See Table 2).		No periodic verification of the battery continuity is required.
Any battery based station dc supply with monitoring and alarming of the intercell and/or terminal connection detail resistance of the entire battery (See Table 2).		No periodic verification of the intercell and terminal connection resistance is required.
Any Valve Regulated Lead-Acid (VRLA) or Vented Lead-Acid (VLA) station battery with internal ohmic value or float current monitoring and alarming, and evaluating present values relative to baseline internal ohmic values for every cell/unit (See Table 2).		No periodic evaluation relative to baseline of battery cell/unit measurements indicative of battery performance is required to verify the station battery can perform as manufactured.
Any Valve Regulated Lead-Acid (VRLA) or Vented Lead-Acid (VLA) station battery with monitoring and alarming of each cell/unit internal ohmic value (See Table 2).		No periodic inspection of the condition of all individual units by measuring battery cell/unit internal ohmic values of a station VRLA or Vented Lead-Acid (VLA) battery is required.

Table 1-5 Component Type - Control Circuitry Associated With Protective Functions Excluding distributed UFLS and distributed UVLS (see Table 3), Automatic Reclosing (see Table 4), and Sudden Pressure Relaying (see Table 5) Note: Table requirements apply to all Control Circuitry Components of Protection Systems, and RAS except as noted.		
Component Attributes	Maximum Maintenance Interval	Maintenance Activities
Trip coils or actuators of circuit breakers, interrupting devices, or mitigating devices (regardless of any monitoring of the control circuitry).	6 Calendar Years	Verify that each trip coil is able to operate the circuit breaker, interrupting device, or mitigating device.
Electromechanical lockout devices which are directly in a trip path from the protective relay to the interrupting device trip coil (regardless of any monitoring of the control circuitry).	6 Calendar Years	Verify electrical operation of electromechanical lockout devices.
Unmonitored control circuitry associated with RAS. (See Table 4-2(b) for RAS which include Automatic Reclosing.)	12 Calendar Years	Verify all paths of the control circuits essential for proper operation of the RAS.
Unmonitored control circuitry associated with protective functions inclusive of all auxiliary relays.	12 Calendar Years	Verify all paths of the trip circuits inclusive of all auxiliary relays through the trip coil(s) of the circuit breakers or other interrupting devices.
Control circuitry associated with protective functions and/or RAS whose integrity is monitored and alarmed (See Table 2).	No periodic maintenance specified	None.

<p align="center">Table 2 – Alarming Paths and Monitoring</p> <p align="center">In Tables 1-1 through 1-5, Table 3, Tables 4-1 through 4-23, and Table 5 alarm attributes used to justify extended maximum maintenance intervals and/or reduced maintenance activities are subject to the following maintenance requirements</p>		
Component Attributes	Maximum Maintenance Interval	Maintenance Activities
<p>Any alarm path through which alarms in Tables 1-1 through 1-5, Table 3, Tables 4-1 through 4-23, and Table 5 are conveyed from the alarm origin to the location where corrective action can be initiated, and not having all the attributes of the “Alarm Path with monitoring” category below.</p> <p>Alarms are reported within 24 hours of detection to a location where corrective action can be initiated.</p>	12 Calendar Years	Verify that the alarm path conveys alarm signals to a location where corrective action can be initiated.
<p>Alarm Path with monitoring:</p> <p>The location where corrective action is taken receives an alarm within 24 hours for failure of any portion of the alarming path from the alarm origin to the location where corrective action can be initiated.</p>	No periodic maintenance specified	None.

Table 3 Maintenance Activities and Intervals for distributed UFLS and distributed UVLS Systems		
Component Attributes	Maximum Maintenance Interval	Maintenance Activities
Any unmonitored protective relay not having all the monitoring attributes of a category below.	6 Calendar Years	<p>Verify that settings are as specified.</p> <p>For non-microprocessor relays:</p> <ul style="list-style-type: none"> • Test and, if necessary calibrate. <p>For microprocessor relays:</p> <ul style="list-style-type: none"> • Verify operation of the relay inputs and outputs that are essential to proper functioning of the Protection System. • Verify acceptable measurement of power system input values.
<p>Monitored microprocessor protective relay with the following:</p> <ul style="list-style-type: none"> • Internal self-diagnosis and alarming (See Table 2). • Voltage and/or current waveform sampling three or more times per power cycle, and conversion of samples to numeric values for measurement calculations by microprocessor electronics. <p>Alarming for power supply failure (See Table 2).</p>	12 Calendar Years	<p>Verify:</p> <ul style="list-style-type: none"> • Settings are as specified. • Operation of the relay inputs and outputs that are essential to proper functioning of the Protection System. • Acceptable measurement of power system input values.
<p>Monitored microprocessor protective relay with preceding row attributes and the following:</p> <ul style="list-style-type: none"> • <u>AeAC</u> measurements are continuously verified by comparison to an independent ac measurement source, with alarming for excessive error (See Table 2). 	12 Calendar Years	<p>Verify only the unmonitored relay inputs and outputs that are essential to proper functioning of the Protection System.</p>

Table 3 Maintenance Activities and Intervals for distributed UFLS and distributed UVLS Systems		
Component Attributes	Maximum Maintenance Interval	Maintenance Activities
<ul style="list-style-type: none"> Some or all binary or status inputs and control outputs are monitored by a process that continuously demonstrates ability to perform as designed, with alarming for failure (See Table 2). Alarming for change of settings (See Table 2).		
Voltage and/or current sensing devices associated with UFLS or UVLS systems.	12 Calendar Years	Verify that current and/or voltage signal values are provided to the protective relays.
Protection System dc supply for tripping non-BES interrupting devices used only for a UFLS or UVLS system.	12 Calendar Years	Verify Protection System dc supply voltage.
Control circuitry between the UFLS or UVLS relays and electromechanical lockout and/or tripping auxiliary devices (excludes non-BES interrupting device trip coils).	12 Calendar Years	Verify the path from the relay to the lockout and/or tripping auxiliary relay (including essential supervisory logic).
Electromechanical lockout and/or tripping auxiliary devices associated only with UFLS or UVLS systems (excludes non-BES interrupting device trip coils).	12 Calendar Years	Verify electrical operation of electromechanical lockout and/or tripping auxiliary devices.
Control circuitry between the electromechanical lockout and/or tripping auxiliary devices and the non-BES interrupting devices in UFLS or UVLS systems, or between UFLS or UVLS relays (with no interposing electromechanical lockout or auxiliary device) and the non-BES interrupting devices (excludes non-BES interrupting device trip coils).	No periodic maintenance specified	None.
Trip coils of non-BES interrupting devices in UFLS or UVLS systems.	No periodic maintenance specified	None.

Table 4-1 Maintenance Activities and Intervals for Automatic Reclosing Components Component Type – Reclosing <u>and Supervisory</u> Relay		
Note: In cases where Components of Automatic Reclosing are common to Components listed in Table 1-1 through 1-5, the Components only need to be tested once during a distinct maintenance interval.		
Component Attributes	Maximum Maintenance Interval	Maintenance Activities
Any unmonitored reclosing relay <u>or supervisory relay</u> not having all the monitoring attributes of a category below.	6 Calendar Years	Verify that settings are as specified. For non-microprocessor <u>reclosing or supervisory</u> relays: <ul style="list-style-type: none"> • Test and, if necessary calibrate For microprocessor <u>reclosing or supervisory</u> relays: <ul style="list-style-type: none"> • <u>Verify operation of the relay inputs and outputs that are essential to proper functioning of the Automatic Reclosing.</u> <u>For microprocessor supervisory relays:</u> <ul style="list-style-type: none"> • <u>Verify acceptable measurement of power system input values.</u>
Monitored microprocessor reclosing relay <u>or supervisory relay</u> with the following: <ul style="list-style-type: none"> • Internal self-diagnosis and alarming (See Table 2). • Alarming for power supply failure (See Table 2). <u>For supervisory relay:</u> <ul style="list-style-type: none"> • <u>Voltage waveform sampling three or more times per power cycle, and conversion of samples to numeric values for measurement calculations by microprocessor electronics.</u> 	12 Calendar Years	Verify: <ul style="list-style-type: none"> • Settings are as specified. • Operation of the relay inputs and outputs that are essential to proper functioning of the Automatic Reclosing. <u>For supervisory relays:</u> <ul style="list-style-type: none"> • <u>Verify acceptable measurement of power system input values.</u>

Table 4-1

Maintenance Activities and Intervals for Automatic Reclosing Components

Component Type – Reclosing and Supervisory Relay

Note: In cases where Components of Automatic Reclosing are common to Components listed in Table 1-1 through 1-5, the Components only need to be tested once during a distinct maintenance interval.

Component Attributes	Maximum Maintenance Interval	Maintenance Activities
<p><u>Monitored microprocessor reclosing relay or supervisory relay with preceding row attributes and the following:</u></p> <ul style="list-style-type: none"> • <u>Some or all binary or status inputs and control outputs are monitored by a process that continuously demonstrates ability to perform as designed, with alarming for failure (See Table 2).</u> • <u>Alarming for change of settings (See Table 2).</u> <p><u>For supervisory relay:</u></p> <ul style="list-style-type: none"> • <u>Ac measurements are continuously verified by comparison to an independent ac measurement source, with alarming for excessive error (See Table 2).</u> 	<p><u>12 Calendar Years</u></p>	<p><u>Verify only the unmonitored relay inputs and outputs that are essential to proper functioning of the Automatic Reclosing.</u></p>

Table 4-2(a)

Maintenance Activities and Intervals for Automatic Reclosing Components

Component Type – Control Circuitry Associated with Reclosing and Supervisory Relays that are NOT an Integral Part of an RAS

Note: In cases where Components of Automatic Reclosing are common to Components listed in Table 1-5, the Components only need to be tested once during a distinct maintenance interval.

Component Attributes	Maximum Maintenance Interval	Maintenance Activities
Unmonitored Control circuitry associated with Automatic Reclosing that is not an integral part of an RAS.	12 Calendar Years	Verify that Automatic Reclosing, upon initiation, does not issue a premature closing command to the close circuitry.
Control circuitry associated with Automatic Reclosing that is not part of an RAS and is monitored and alarmed for conditions that would result in a premature closing command. (See Table 2)	No periodic maintenance specified	None.

Table 4-2(b)

Maintenance Activities and Intervals for Automatic Reclosing Components

Component Type – Control Circuitry Associated with Reclosing and Supervisory Relays that ARE an Integral Part of an RAS

Note: In cases where Components of Automatic Reclosing are common to Components listed in Table 1-5, the Components only need to be tested once during a distinct maintenance interval.

Component Attributes	Maximum Maintenance Interval	Maintenance Activities
Close coils or actuators of circuit breakers or similar devices that are used in conjunction with Automatic Reclosing as part of an RAS (regardless of any monitoring of the control circuitry).	6 Calendar Years	Verify that each close coil or actuator is able to operate the circuit breaker or mitigating device.
Unmonitored close control circuitry associated with Automatic Reclosing used as an integral part of an RAS.	12 Calendar Years	Verify all paths of the control circuits associated with Automatic Reclosing that are essential for proper operation of the RAS.
Control circuitry associated with Automatic Reclosing that is an integral part of an RAS whose integrity is monitored and alarmed. (See Table 2)	No periodic maintenance specified	None.

Table 4-3

Maintenance Activities and Intervals for Automatic Reclosing Components

Component Type – Voltage Sensing Devices Associated with Supervisory Relays

Note: In cases where Components of Automatic Reclosing are common to Components listed in Table 1-3, the Components only need to be tested once during a distinct maintenance interval.

<u>Component Attributes</u>	<u>Maximum Maintenance Interval</u>	<u>Maintenance Activities</u>
<u>Any voltage sensing devices not having monitoring attributes of the category below.</u>	<u>12 Calendar Years</u>	<u>Verify that voltage signal values are provided to the supervisory relays.</u>
<u>Voltage sensing devices that are connected to microprocessor supervisory relays with ac measurements that are continuously verified by comparison of sensing input value, as measured by the microprocessor relay, to an independent ac measurement source, with alarming for unacceptable error or failure. (See Table 2)</u>	<u>No periodic maintenance specified</u>	<u>None.</u>

<p style="text-align: center;">Table 5 Maintenance Activities and Intervals for Sudden Pressure Relaying</p>		
<p style="text-align: center;">Note: In cases where Components of Sudden Pressure Relaying are common to Components listed in Table 1-5, the Components only need to be tested once during a distinct maintenance interval.</p>		
Component Attributes	Maximum Maintenance Interval	Maintenance Activities
Any fault pressure relay.	6 Calendar Years	Verify the pressure or flow sensing mechanism is operable.
Electromechanical lockout devices which are directly in a trip path from the fault pressure relay to the interrupting device trip coil (regardless of any monitoring of the control circuitry).	6 Calendar Years	Verify electrical operation of electromechanical lockout devices.
Unmonitored control circuitry associated with Sudden Pressure Relaying.	12 Calendar Years	Verify all paths of the trip circuits inclusive of all auxiliary relays through the trip coil(s) of the circuit breakers or other interrupting devices.
Control circuitry associated with Sudden Pressure Relaying whose integrity is monitored and alarmed (See Table 2).	No periodic maintenance specified	None.

PRC-005 — Attachment A

Criteria for a Performance-Based Protection System Maintenance Program

Purpose: To establish a technical basis for initial and continued use of a performance-based Protection System Maintenance Program (PSMP).

To establish the technical justification for the initial use of a performance-based PSMP:

1. Develop a list with a description of Components included in each designated Segment, with a minimum Segment population of 60 Components.
2. Maintain the Components in each Segment according to the time-based maximum allowable intervals established in Tables 1-1 through 1-5, Table 3, Tables 4-1 through 4-~~23~~, and Table 5 until results of maintenance activities for the Segment are available for a minimum of 30 individual Components of the Segment.
3. Document the maintenance program activities and results for each Segment, including maintenance dates and Countable Events for each included Component.
4. Analyze the maintenance program activities and results for each Segment to determine the overall performance of the Segment and develop maintenance intervals.
5. Determine the maximum allowable maintenance interval for each Segment such that the Segment experiences Countable Events on no more than 4% of the Components within the Segment, for the greater of either the last 30 Components maintained or all Components maintained in the previous year.

To maintain the technical justification for the ongoing use of a performance-based PSMP:

1. At least annually, update the list of Components and Segments and/or description if any changes occur within the Segment.
2. Perform maintenance on the greater of 5% of the Components (addressed in the performance based PSMP) in each Segment or 3 individual Components within the Segment in each year.
3. For the prior year, analyze the maintenance program activities and results for each Segment to determine the overall performance of the Segment.
4. Using the prior year's data, determine the maximum allowable maintenance interval for each Segment such that the Segment experiences Countable Events on no more than 4% of the Components within the Segment, for the greater of either the last 30 Components maintained or all Components maintained in the previous year.

If the Components in a Segment maintained through a performance-based PSMP experience 4% or more Countable Events, develop, document, and implement an action plan to reduce the Countable Events to less than 4% of the Segment population within 3 years.

Rationale:

During development of this standard, text boxes were embedded within the standard to explain the rationale for various parts of the standard. Upon BOT approval, the text from the rationale text boxes was moved to this section.

Rationale for Applicability Section:

~~This section does not reflect the applicability changes that will be proposed by the Project 2014-01 Standards Applicability for Dispersed Generation Resources standards drafting team. The changes in this posted version and those being made by the Project 2014-01 standards drafting team do not overlap.~~

~~Additionally, to align with ongoing NERC standards development in Project 2010-05.2: Special Protection Systems, the term "Special Protection Systems" in PRC-005-4 was replaced by the term "Remedial Action Schemes." These terms are synonymous in the NERC Glossary of Terms.~~

Rationale for the deletion of part of the definition of Component:

~~The SDT determined that it was explanatory in nature and adequately addressed in the Supplementary Reference and FAQ Document.~~

Rationale for R3 Part 3.1:

~~In the last posting, the SDT included language in the standard that was originally in the implementation plan that required completion of maintenance activities within three years for newly identified Automatic Reclosing Components following a notification under Requirement R6, which has been removed. After further discussion, the SDT determined that a separate shorter timeframe for maintenance of newly identified Automatic Reclosing Components created unnecessary complication within the standard. The SDT agreed that entities should be responsible for maintaining the Automatic Reclosing Components subject to the standard, whether existing, newly added or newly within scope based on a change in the largest generating unit in the BA or, if a member of a Reserve Sharing Group, the largest generating unit within the Reserve Sharing Group according to the timeframes in the maintenance tables. Therefore, 3.1 and its subparts have been removed and have not been reinserted into the implementation plan.~~

Rationale for R4 Part 4.1:

~~In the last posting, the SDT included language in the standard that was originally in the implementation plan that required completion of maintenance activities within three years for newly identified Automatic Reclosing Components following a notification under Requirement R6, which has been removed. After further discussion, the SDT determined that a separate shorter timeframe for maintenance of newly identified Automatic Reclosing Components created unnecessary complication within the standard. The SDT agreed that entities should be responsible for maintaining the Automatic Reclosing Components subject to the standard, whether existing, newly added or newly within scope based on a change in the largest~~

~~generating unit in the BA or, if a member of a Reserve Sharing Group, the largest generating unit within the Reserve Sharing Group according to the timeframes in the maintenance tables. Therefore, 4.1 and its subparts have been removed and have not been reinserted into the implementation plan.~~

Rationale for revisions to Automatic Reclosing:

To address directives from FERC Order No. 803 addressing Automatic Reclosing, the definition for Automatic Reclosing was revised to add supervisory relays, the associated voltage sensing devices, and the associated control circuitry.

Rationale for revisions to Component Type:

With the revision of the definition of Automatic Reclosing, there are four specific elements of this definition, rather than two as stated in the prior version.

Redline Version

PRC-005-6 to PRC-005-5

A. Introduction

1. **Title:** Protection System, Automatic Reclosing, and Sudden Pressure Relaying Maintenance
2. **Number:** PRC-005-~~56~~
3. **Purpose:** To document and implement programs for the maintenance of all Protection Systems, Automatic Reclosing, and Sudden Pressure Relaying affecting the reliability of the Bulk Electric System (BES) so that they are kept in working order.
4. **Applicability:**
 - 4.1. **Functional Entities:**
 - 4.1.1 Transmission Owner
 - 4.1.2 Generator Owner
 - 4.1.3 Distribution Provider
 - 4.2. **Facilities:**
 - 4.2.1 Protection Systems and Sudden Pressure Relaying that are installed for the purpose of detecting Faults on BES Elements (lines, buses, transformers, etc.)
 - 4.2.2 Protection Systems used for underfrequency load-shedding systems installed per ERO underfrequency load-shedding requirements.
 - 4.2.3 Protection Systems used for undervoltage load-shedding systems installed to prevent system voltage collapse or voltage instability for BES reliability.
 - 4.2.4 Protection Systems installed as a Remedial Action Scheme (RAS) for BES reliability.
 - 4.2.5 Protection Systems and Sudden Pressure Relaying for generator Facilities that are part of the BES, except for generators identified through Inclusion I4 of the BES definition, including:
 - 4.2.5.1 Protection Systems that act to trip the generator either directly or via lockout or auxiliary tripping relays.
 - 4.2.5.2 Protection Systems and Sudden Pressure Relaying for generator step-up transformers for generators that are part of the BES.
 - 4.2.5.3 Protection Systems and Sudden Pressure Relaying for station service or excitation transformers connected to the generator bus of generators which are part of the BES, that act to trip the generator either directly or via lockout or tripping auxiliary relays.

4.2.6 Protection Systems and Sudden Pressure Relaying for the following BES generator Facilities for dispersed power producing resources identified through Inclusion I4 of the BES definition:

4.2.6.1 Protection Systems and Sudden Pressure Relaying for Facilities used in aggregating dispersed BES generation from the point where those resources aggregate to greater than 75 MVA to a common point of connection at 100kV or above.

4.2.7 Automatic Reclosing¹, including:

4.2.7.1 Automatic Reclosing applied on the terminals of Elements connected to the BES bus located at generating plant substations where the total installed gross generating plant capacity is greater than the gross capacity of the largest BES generating unit within the Balancing Authority Area or, if a member of a Reserve Sharing Group, the largest generating unit within the Reserve Sharing Group.²

4.2.7.2 Automatic Reclosing applied on the terminals of all BES Elements at substations one bus away from generating plants specified in Section 4.2.7.1 when the substation is less than 10 circuit-miles from the generating plant substation.

4.2.7.3 Automatic Reclosing applied as an integral part of an RAS specified in Section 4.2.4.

5. Effective Date: See the Implementation Plan for this standard.

6. Definitions Used in this Standard:

Automatic Reclosing – Includes the following Components:

- Reclosing relay
- Supervisory relay(s) or function(s) – relay(s) or function(s) that perform voltage and/or sync check functions that enable or disable operation of the reclosing relay
- Voltage sensing devices associated with the supervisory relay(s) or function(s)

¹ Automatic Reclosing addressed in Section 4.2.7.1 and 4.2.7.2 may be excluded if the equipment owner can demonstrate that a close-in three-phase fault present for twice the normal clearing time (capturing a minimum trip-close-trip time delay) does not result in a total loss of gross generation in the Interconnection exceeding the gross capacity of the largest relevant BES generating unit where the Automatic Reclosing is applied.

² The largest BES generating unit within the Balancing Authority Area or the largest generating unit within the Reserve Sharing Group, as applicable, is subject to change. As a result of such a change, the Automatic Reclosing Components subject to the standard could change effective on the date of such change.

- Control circuitry associated with the reclosing relay- or supervisory relay(s) or function(s)

Sudden Pressure Relaying – A system that trips an interrupting device(s) to isolate the equipment it is monitoring and includes the following Components:

- Fault pressure relay – a mechanical relay or device that detects rapid changes in gas pressure, oil pressure, or oil flow that are indicative of Faults within liquid-filled, wire-wound equipment
- Control circuitry associated with a fault pressure relay

Unresolved Maintenance Issue – A deficiency identified during a maintenance activity that causes the Component to not meet the intended performance, cannot be corrected during the maintenance interval, and requires follow-up corrective action.

Segment – Components of a consistent design standard, or a particular model or type from a single manufacturer that typically share other common elements. Consistent performance is expected across the entire population of a Segment. A Segment must contain at least sixty (60) individual Components.

Component Type –

- Any one of the five specific elements of a Protection System-
- Any one of the ~~two~~four specific elements of Automatic Reclosing-
- Any one of the two specific elements of Sudden Pressure Relaying-

Component – Any individual discrete piece of equipment included in a Protection System, Automatic Reclosing, or Sudden Pressure Relaying.

Countable Event – A failure of a Component requiring repair or replacement, any condition discovered during the maintenance activities in Tables 1-1 through 1-5, Table 3, Tables 4-1 through 4-~~23~~, and Table 5, which requires corrective action or a Protection System Misoperation attributed to hardware failure or calibration failure.

Misoperations due to product design errors, software errors, relay settings different from specified settings, Protection System Component, Automatic Reclosing, or Sudden Pressure Relaying configuration or application errors are not included in Countable Events.

B. Requirements and Measures

- R1.** Each Transmission Owner, Generator Owner, and Distribution Provider shall establish a Protection System Maintenance Program (PSMP) for its Protection Systems, Automatic Reclosing, and Sudden Pressure Relaying identified in Section 4.2, Facilities. *[Violation Risk Factor: Medium] [Time Horizon: Operations Planning]*

The PSMP shall:

- 1.1. Identify which maintenance method (time-based, performance-based per PRC-005 Attachment A, or a combination) is used to address each Protection System, Automatic Reclosing, and Sudden Pressure Relaying Component Type. All batteries associated with the station dc supply Component Type of a Protection System shall be included in a time-based program as described in Table 1-4 and Table 3.
 - 1.2. Include the applicable monitored Component attributes applied to each Protection System, Automatic Reclosing, and Sudden Pressure Relaying Component Type consistent with the maintenance intervals specified in Tables 1-1 through 1-5, Table 2, Table 3, Table 4-1 through 4-23, and Table 5 where monitoring is used to extend the maintenance intervals beyond those specified for unmonitored Protection System, Automatic Reclosing, and Sudden Pressure Relaying Components.
- M1. Each Transmission Owner, Generator Owner and Distribution Provider shall have a documented ~~Protection System Maintenance Program~~ PSMP in accordance with Requirement R1.

For each Protection System, Automatic Reclosing, and Sudden Pressure Relaying Component Type, the documentation shall include the type of maintenance method applied (time-based, performance-based, or a combination of these maintenance methods), and shall include all batteries associated with the station dc supply Component Types in a time-based program as described in Table 1-4 and Table 3. (Part 1.1)

For Component Types that use monitoring to extend the maintenance intervals, the responsible entity(s) shall have evidence for each Protection System, Automatic Reclosing, and Sudden Pressure Relaying Component Type (such as manufacturer's specifications or engineering drawings) of the appropriate monitored Component attributes as specified in Tables 1-1 through 1-5, Table 2, Table 3, Table 4-1 through 4-23, and Table 5. (Part 1.2)
- R2. Each Transmission Owner, Generator Owner, and Distribution Provider that uses performance-based maintenance intervals in its PSMP shall follow the procedure established in PRC-005 Attachment A to establish and maintain its performance-based intervals. *[Violation Risk Factor: Medium] [Time Horizon: Operations Planning]*
- M2. Each Transmission Owner, Generator Owner, and Distribution Provider that uses performance-based maintenance intervals shall have evidence that its current performance-based maintenance program(s) is in accordance with Requirement R2, which may include, but is not limited to, Component lists, dated maintenance records, and dated analysis records and results.
- R3. Each Transmission Owner, Generator Owner, and Distribution Provider that utilizes time-based maintenance program(s) shall maintain its Protection System, Automatic Reclosing, and Sudden Pressure Relaying Components that are included within the time-based maintenance program in accordance with the minimum maintenance

activities and maximum maintenance intervals prescribed within Tables 1-1 through 1-5, Table 2, Table 3, Table 4-1 through 4-23, and Table 5. *[Violation Risk Factor: High] [Time Horizon: Operations Planning]*

- M3.** Each Transmission Owner, Generator Owner, and Distribution Provider that utilizes time-based maintenance program(s) shall have evidence that it has maintained its Protection System, Automatic Reclosing, and Sudden Pressure Relaying Components included within its time-based program in accordance with Requirement R3. The evidence may include, but is not limited to, dated maintenance records, dated maintenance summaries, dated check-off lists, dated inspection records, or dated work orders.
- R4.** Each Transmission Owner, Generator Owner, and Distribution Provider that utilizes performance-based maintenance program(s) in accordance with Requirement R2 shall implement and follow its PSMP for its Protection System, Automatic Reclosing, and Sudden Pressure Relaying Components that are included within the performance-based program(s). *[Violation Risk Factor: High] [Time Horizon: Operations Planning]*
- M4.** Each Transmission Owner, Generator Owner, and Distribution Provider that utilizes performance-based maintenance intervals in accordance with Requirement R2 shall have evidence that it has implemented the ~~Protection System Maintenance Program~~ **PSMP** for the Protection System, Automatic Reclosing, and Sudden Pressure Relaying Components included in its performance-based program in accordance with Requirement R4. The evidence may include, but is not limited to, dated maintenance records, dated maintenance summaries, dated check-off lists, dated inspection records, or dated work orders.
- R5.** Each Transmission Owner, Generator Owner, and Distribution Provider shall demonstrate efforts to correct identified Unresolved Maintenance Issues. *[Violation Risk Factor: Medium] [Time Horizon: Operations Planning]*
- M5.** Each Transmission Owner, Generator Owner, and Distribution Provider shall have evidence that it has undertaken efforts to correct identified Unresolved Maintenance Issues in accordance with Requirement R5. The evidence may include, but is not limited to, work orders, replacement Component orders, invoices, project schedules with completed milestones, return material authorizations (RMAs) or purchase orders.

C. Compliance

1. Compliance Monitoring Process

1.1. Compliance Enforcement Authority

As defined in the NERC Rules of Procedure, “Compliance Enforcement Authority” means NERC or the Regional Entity in their respective roles of monitoring and enforcing compliance with the NERC Reliability Standards.

1.2. Evidence Retention

The following evidence retention periods identify the period of time an entity is required to retain specific evidence to demonstrate compliance. For instances where the evidence retention period specified below is shorter than the time since the last audit, the Compliance Enforcement Authority may ask an entity to provide other evidence to show that it was compliant for the full time period since the last audit.

The Transmission Owner, Generator Owner, and Distribution Provider shall each keep data or evidence to show compliance as identified below unless directed by its Compliance Enforcement Authority to retain specific evidence for a longer period of time as part of an investigation.

For Requirement R1, the Transmission Owner, Generator Owner, and Distribution Provider shall each keep its current dated ~~Protection System Maintenance Program~~ PSMP, as well as any superseded versions since the preceding compliance audit, including the documentation that specifies the type of maintenance program applied for each Protection System, Automatic Reclosing, or Sudden Pressure Relaying Component Type.

For Requirement R2, Requirement R3, and Requirement R4, in cases where the interval of the maintenance activity is longer than the audit cycle, the Transmission Owner, Generator Owner, and Distribution Provider shall each keep documentation of the most recent performance of that maintenance activity for the Protection System, Automatic Reclosing, or Sudden Pressure Relaying Component. In cases where the interval of the maintenance activity is shorter than the audit cycle, documentation of all performances (in accordance with the tables) of that maintenance activity for the Protection System, Automatic Reclosing, or Sudden Pressure Relaying Component since the previous scheduled audit date shall be retained.

For Requirement R5 the Transmission Owner, Generator Owner, and Distribution Provider shall each keep documentation of Unresolved Maintenance Issues identified by the entity since the last audit, including all that were resolved since the last audit.

~~The Compliance Enforcement Authority shall keep the last audit records and all requested and submitted subsequent audit records.~~

1.3. Compliance Monitoring and Assessment Processes:

Compliance Audits

Self-Certifications

Spot Checking

Compliance ~~Violation~~ Investigations

Self-Reporting

Complaints

1.4. Additional Compliance Information

None

Table of Compliance Elements

Requirement Number	Lower VSL	Moderate VSL	High VSL	Severe VSL
R1	The entity’s PSMP failed to specify whether one Component Type is being addressed by time-based or performance-based maintenance, or a combination of both (Part 1.1).	The entity’s PSMP failed to specify whether two Component Types are being addressed by time-based or performance-based maintenance, or a combination of both (Part 1.1).	<p>The entity’s PSMP failed to specify whether three Component Types are being addressed by time-based or performance-based maintenance, or a combination of both. (Part 1.1).</p> <p>OR</p> <p>The entity’s PSMP failed to include the applicable monitoring attributes applied to each Component Type consistent with the maintenance intervals specified in Tables 1-1 through 1-5, Table 2, Table 3, Tables 4-1 through 4-23, and Table 5 where monitoring is used to extend the maintenance intervals beyond those specified for unmonitored Components (Part 1.2).</p>	<p>The entity failed to establish a PSMP.</p> <p>OR</p> <p>The entity’s PSMP failed to specify whether four or more Component Types are being addressed by time-based or performance-based maintenance, or a combination of both (Part 1.1).</p> <p>OR</p> <p>The entity’s PSMP failed to include applicable station batteries in a time-based program (Part 1.1).</p>
R2	The entity uses performance-based maintenance intervals in its PSMP but failed to reduce Countable Events to no more than 4% within three years.	NA	The entity uses performance-based maintenance intervals in its PSMP but failed to reduce Countable Events to no more than 4% within four years.	<p>The entity uses performance-based maintenance intervals in its PSMP but:</p> <ol style="list-style-type: none"> 1) Failed to establish the technical justification described within Requirement R2 for the initial use of the performance-based PSMP <p>OR</p> <ol style="list-style-type: none"> 2) Failed to reduce Countable Events to no more than 4% within five years <p>OR</p>

Requirement Number	Lower VSL	Moderate VSL	High VSL	Severe VSL
				3) Maintained a Segment with less than 60 Components OR 4) Failed to: <ul style="list-style-type: none"> • Annually update the list of Components, OR • Annually perform maintenance on the greater of 5% of the Segment population or 3 Components, OR • Annually analyze the program activities and results for each Segment.
R3	For Components included within a time-based maintenance program, the entity failed to maintain 5% or less of the total Components included within a specific Component Type in accordance with the minimum maintenance activities and maximum maintenance intervals prescribed within Tables 1-1 through 1-5, Table 2, Table 3, Tables 4-1 through 4-23, and Table 5.	For Components included within a time-based maintenance program, the entity failed to maintain more than 5% but 10% or less of the total Components included within a specific Component Type in accordance with the minimum maintenance activities and maximum maintenance intervals prescribed within Tables 1-1 through 1-5, Table 2, Table 3, Tables 4-1 through 4-23, and Table 5.	For Components included within a time-based maintenance program, the entity failed to maintain more than 10% but 15% or less of the total Components included within a specific Component Type in accordance with the minimum maintenance activities and maximum maintenance intervals prescribed within Tables 1-1 through 1-5, Table 2, Table 3, Tables 4-1 through 4-23, and Table 5.	For Components included within a time-based maintenance program, the entity failed to maintain more than 15% of the total Components included within a specific Component Type in accordance with the minimum maintenance activities and maximum maintenance intervals prescribed within Tables 1-1 through 1-5, Table 2, Table 3, Tables 4-1 through 4-23, and Table 5.

Requirement Number	Lower VSL	Moderate VSL	High VSL	Severe VSL
R4	For Components included within a performance-based maintenance program, the entity failed to maintain 5% or less of the annual scheduled maintenance for a specific Component Type in accordance with their performance-based PSMP.	For Components included within a performance-based maintenance program, the entity failed to maintain more than 5% but 10% or less of the annual scheduled maintenance for a specific Component Type in accordance with their performance-based PSMP.	For Components included within a performance-based maintenance program, the entity failed to maintain more than 10% but 15% or less of the annual scheduled maintenance for a specific Component Type in accordance with their performance-based PSMP.	For Components included within a performance-based maintenance program, the entity failed to maintain more than 15% of the annual scheduled maintenance for a specific Component Type in accordance with their performance-based PSMP.
R5	The entity failed to undertake efforts to correct 5 or fewer identified Unresolved Maintenance Issues.	The entity failed to undertake efforts to correct greater than 5 but less than or equal to 10 identified Unresolved Maintenance Issues.	The entity failed to undertake efforts to correct greater than 10 but less than or equal to 15 identified Unresolved Maintenance Issues.	The entity failed to undertake efforts to correct greater than 15 identified Unresolved Maintenance Issues.

D. Regional Variances

None.

E. Interpretations

None.

Supplemental Reference Documents

The following documents present a detailed discussion about determination of maintenance intervals and other useful information regarding establishment of a maintenance program.

1. *Supplementary Reference and FAQ - PRC-005-~~46~~ Protection System Maintenance*, Protection System Maintenance and Testing Standard Drafting Team (~~April 2014~~July 2015)
2. *Considerations for Maintenance and Testing of Auto-reclosing Schemes*, NERC System Analysis and Modeling Subcommittee, and NERC System Protection and Control Subcommittee (November 2012)
3. *Sudden Pressure Relays and Other Devices that Respond to Non-Electrical Quantities – SPCS Input for Standard Development in Response to FERC Order No. 758*, NERC System Protection and Control Subcommittee (December 2013)
4. *Sudden Pressure Relays and Other Devices that Respond to Non-Electrical Quantities – Supplemental Information to Support Project 2007-17.3: Protection System Maintenance and Testing* (October 31, 2014)

Version History

Version	Date	Action	Change Tracking
0	February 8, 2005	Adopted by NERC Board of Trustees	New
1	February 7, 2006	Adopted by NERC Board of Trustees	<ol style="list-style-type: none"> 1. Changed incorrect use of certain hyphens (-) to “en dash” (–) and “em dash (—).” 2. Added “periods” to items where appropriate. Changed “Timeframe” to “Time Frame” in item D, 1.2.
1	March 16, 2007	PRC-005-1 Approved by FERC. Docket No. RM06-16-000	

Version	Date	Action	Change Tracking
1a	February 17, 2011	Adopted by NERC Board of Trustees	Added Appendix 1 - Interpretation regarding applicability of standard to protection of radially connected transformers developed in Project 2009-17
1a	September 26, 2011	Approved by FERC. Docket No. RD11-5-000	
1b	November 5, 2009	Adopted by NERC Board of Trustees	Interpretation of R1, R1.1, and R1.2 developed by Project 2009-10
1b	February 3, 2012	FERC Order approving revised definition of “Protection System”	Per footnote 8 of FERC’s order, the definition of “Protection System” supersedes interpretation “b” of PRC-005-1b upon the effective date of the modified definition (i.e., April 1, 2013) <i>See N. Amer. Elec. Reliability Corp., 138 FERC ¶ 61,095 (February 3, 2012).</i>
1b	February 3, 2012	PRC-005-1b Approved by FERC. Docket No. RM10-5-000	
1.1b	May 9, 2012	Adopted by NERC Board of Trustees	Errata change developed by Project 2010-07, clarified inclusion of generator interconnection Facility in Generator Owner’s responsibility
1.1b	September 19, 2013	PRC-005-1.1b Approved by FERC. Docket No. RM12-16-000	
2	November 7, 2012	Adopted by NERC Board of Trustees	Project 2007-17 - Complete revision, absorbing maintenance requirements from PRC-005-1.1b, PRC-008-0, PRC-011-0, PRC-017-0

Version	Date	Action	Change Tracking
2	October 17, 2013	Approved by NERC Standards Committee	Errata Change: The Standards Committee approved an errata change to the implementation plan for PRC-005-2 to add the phrase “or as otherwise made effective pursuant to the laws applicable to such ERO governmental authorities;” to the second sentence under the “Retirement of Existing Standards” section. (no change to standard version number)
2	December 19, 2013	PRC-005-2 Approved by FERC. Docket No. RM13-7-000	
2	March 7, 2014	Adopted by NERC Board of Trustees	Modified R1 VSL in response to FERC directive (no change to standard version number)
2(i)	November 13, 2014	Adopted by NERC Board of Trustees	Applicability section revised by Project 2014-01 to clarify application of Requirements to BES dispersed power producing resources
2(i)	May 29, 2015	PRC-005-2(i) Approved by FERC. Docket No. RD15-3-000	
2(ii)	November 13, 2014	Adopted by NERC Board of Trustees	Replaced references to Special Protection System and SPS with Remedial Action Scheme and RAS
3	November 7, 2013	Adopted by the NERC Board of Trustees	Revised to address the FERC directive in Order No. 758 to include Automatic Reclosing in maintenance programs

Version	Date	Action	Change Tracking
3	February 12, 2014	Approved by NERC Standards Committee	Errata Change: The Standards Committee approved errata changes to correct capitalization of certain defined terms within the definitions of “Unresolved Maintenance Issue” and “Protection System Maintenance Program”. The changes will be reflected in the definitions section of PRC-005-3 for “Unresolved Maintenance Issue” and in the NERC Glossary of Terms for “Protection System Maintenance Program”. (no change to standard version number)
3	March 7, 2014	Adopted by NERC Board of Trustees	Modified R1 VSL in response to FERC directive (no change to standard version number)
3	January 22, 2015	PRC-005-3 Approved by FERC. Docket No. RM14-8-000	
3(i)	November 13, 2014	Adopted by NERC Board of Trustees	Applicability section revised by Project 2014-01 to clarify application of Requirements to BES dispersed power producing resources
3(i)	May 29, 2015	PRC-005-3(i) Approved by FERC. Docket No. RD15-3-000	
3(ii)	November 13, 2014	Adopted by NERC Board of Trustees	Replaced references to Special Protection System and SPS with Remedial Action Scheme and RAS
4	November 13, 2014	Adopted by NERC Board of Trustees	Added Sudden Pressure Relaying in response to FERC Order No. 758
4	September Sept 17, 2015	PRC-005-4 Approved by FERC. Docket No. RM15-9-000	

Version	Date	Action	Change Tracking
5	May 7, 2015	Adopted by NERC Board of Trustees	Applicability section revised by Project 2014-01 to clarify application of Requirements to BES dispersed power producing resources.
<u>6</u>	<u>November 5, 2015</u>	<u>Adopted by NERC Board of Trustees</u>	<u>Revised to add supervisory relays, the voltage sensing devices, and the associated control circuitry to Automatic Reclosing in accordance with the directives in FERC Order 803.</u>

Table 1-1 Component Type - Protective Relay Excluding distributed UFLS and distributed UVLS (see Table 3)		
Component Attributes	Maximum Maintenance Interval ³	Maintenance Activities
Any unmonitored protective relay not having all the monitoring attributes of a category below.	6 Calendar Years	For all unmonitored relays: <ul style="list-style-type: none"> • Verify that settings are as specified For non-microprocessor relays: <ul style="list-style-type: none"> • Test and, if necessary calibrate For microprocessor relays: <ul style="list-style-type: none"> • Verify operation of the relay inputs and outputs that are essential to proper functioning of the Protection System. • Verify acceptable measurement of power system input values.
Monitored microprocessor protective relay with the following: <ul style="list-style-type: none"> • Internal self-diagnosis and alarming (see Table 2). • Voltage and/or current waveform sampling three or more times per power cycle, and conversion of samples to numeric values for measurement calculations by microprocessor electronics. • Alarming for power supply failure (see Table 2). 	12 Calendar Years	Verify: <ul style="list-style-type: none"> • Settings are as specified. • Operation of the relay inputs and outputs that are essential to proper functioning of the Protection System. • Acceptable measurement of power system input values.

³ For the tables in this standard, a calendar year starts on the first day of a new year (January 1) after a maintenance activity has been completed. For the tables in this standard, a calendar month starts on the first day of the first month after a maintenance activity has been completed.

Table 1-1 Component Type - Protective Relay Excluding distributed UFLS and distributed UVLS (see Table 3)		
Component Attributes	Maximum Maintenance Interval ³	Maintenance Activities
Monitored microprocessor protective relay with preceding row attributes and the following: <ul style="list-style-type: none"> • Ac measurements are continuously verified by comparison to an independent ac measurement source, with alarming for excessive error (See Table 2). • Some or all binary or status inputs and control outputs are monitored by a process that continuously demonstrates ability to perform as designed, with alarming for failure (See Table 2). • Alarming for change of settings (See Table 2). 	12 Calendar Years	Verify only the unmonitored relay inputs and outputs that are essential to proper functioning of the Protection System.

Table 1-2 Component Type - Communications Systems Excluding distributed UFLS and distributed UVLS (see Table 3)		
Component Attributes	Maximum Maintenance Interval	Maintenance Activities
Any unmonitored communications system necessary for correct operation of protective functions, and not having all the monitoring attributes of a category below.	4 Calendar Months	Verify that the communications system is functional.
	6 Calendar Years	Verify that the communications system meets performance criteria pertinent to the communications technology applied (e.g. signal level, reflected power, or data error rate). Verify operation of communications system inputs and outputs that are essential to proper functioning of the Protection System.
Any communications system with continuous monitoring or periodic automated testing for the presence of the channel function, and alarming for loss of function (See Table 2).	12 Calendar Years	Verify that the communications system meets performance criteria pertinent to the communications technology applied (e.g. signal level, reflected power, or data error rate). Verify operation of communications system inputs and outputs that are essential to proper functioning of the Protection System.
Any communications system with all of the following: <ul style="list-style-type: none"> • Continuous monitoring or periodic automated testing for the performance of the channel using criteria pertinent to the communications technology applied (e.g. signal level, reflected power, or data error rate, and alarming for excessive performance degradation). (See Table 2) • Some or all binary or status inputs and control outputs are monitored by a process that continuously demonstrates ability to perform as designed, with alarming for failure (See Table 2). 	12 Calendar Years	Verify only the unmonitored communications system inputs and outputs that are essential to proper functioning of the Protection System

Table 1-3 Component Type - Voltage and Current Sensing Devices Providing Inputs to Protective Relays Excluding distributed UFLS and distributed UVLS (see Table 3)		
Component Attributes	Maximum Maintenance Interval	Maintenance Activities
Any voltage and current sensing devices not having monitoring attributes of the category below.	12 Calendar Years	Verify that current and voltage signal values are provided to the protective relays.
Voltage and Current Sensing devices connected to microprocessor relays with <u>ACac</u> measurements <u>that</u> are continuously verified by comparison of sensing input value, as measured by the microprocessor relay, to an independent ac measurement source, with alarming for unacceptable error or failure (see Table 2).	No periodic maintenance specified	None.

Table 1-4(a) Component Type – Protection System Station dc Supply Using Vented Lead-Acid (VLA) Batteries Excluding distributed UFLS and distributed UVLS (see Table 3)		
Protection System Station dc supply used only for non-BES interrupting devices for RAS, non-distributed UFLS systems, or non-distributed UVLS systems is excluded (see Table 1-4(e)).		
Component Attributes	Maximum Maintenance Interval	Maintenance Activities
Protection System Station dc supply using Vented Lead-Acid (VLA) batteries not having monitoring attributes of Table 1-4(f).	4 Calendar Months	Verify: <ul style="list-style-type: none"> • Station dc supply voltage Inspect: <ul style="list-style-type: none"> • Electrolyte level • For unintentional grounds
	18 Calendar Months	Verify: <ul style="list-style-type: none"> • Float voltage of battery charger • Battery continuity • Battery terminal connection resistance • Battery intercell or unit-to-unit connection resistance Inspect: <ul style="list-style-type: none"> • Cell condition of all individual battery cells where cells are visible – or measure battery cell/unit internal ohmic values where the cells are not visible • Physical condition of battery rack

Table 1-4(a) Component Type – Protection System Station dc Supply Using Vented Lead-Acid (VLA) Batteries Excluding distributed UFLS and distributed UVLS (see Table 3)		
Protection System Station dc supply used only for non-BES interrupting devices for RAS, non-distributed UFLS systems, or non-distributed UVLS systems is excluded (see Table 1-4(e)).		
Component Attributes	Maximum Maintenance Interval	Maintenance Activities
	18 Calendar Months -or- 6 Calendar Years	Verify that the station battery can perform as manufactured by evaluating cell/unit measurements indicative of battery performance (e.g. internal ohmic values or float current) against the station battery baseline. -or- Verify that the station battery can perform as manufactured by conducting a performance or modified performance capacity test of the entire battery bank.

Table 1-4(b) Component Type – Protection System Station dc Supply Using Valve-Regulated Lead-Acid (VRLA) Batteries Excluding distributed UFLS and distributed UVLS (see Table 3)		
Protection System Station dc supply used only for non-BES interrupting devices for RAS, non-distributed UFLS systems, or non-distributed UVLS systems is excluded (see Table 1-4(e)).		
Component Attributes	Maximum Maintenance Interval	Maintenance Activities
Protection System Station dc supply with Valve Regulated Lead-Acid (VRLA) batteries not having monitoring attributes of Table 1-4(f).	4 Calendar Months	Verify: <ul style="list-style-type: none"> • Station dc supply voltage Inspect: <ul style="list-style-type: none"> • For unintentional grounds
	6 Calendar Months	Inspect: <ul style="list-style-type: none"> • Condition of all individual units by measuring battery cell/unit internal ohmic values.
	18 Calendar Months	Verify: <ul style="list-style-type: none"> • Float voltage of battery charger • Battery continuity • Battery terminal connection resistance • Battery intercell or unit-to-unit connection resistance Inspect: <ul style="list-style-type: none"> • Physical condition of battery rack

<p style="text-align: center;">Table 1-4(b) Component Type – Protection System Station dc Supply Using Valve-Regulated Lead-Acid (VRLA) Batteries Excluding distributed UFLS and distributed UVLS (see Table 3)</p> <p style="text-align: center;">Protection System Station dc supply used only for non-BES interrupting devices for RAS, non-distributed UFLS systems, or non-distributed UVLS systems is excluded (see Table 1-4(e)).</p>		
Component Attributes	Maximum Maintenance Interval	Maintenance Activities
	6 Calendar Months -or- 3 Calendar Years	Verify that the station battery can perform as manufactured by evaluating cell/unit measurements indicative of battery performance (e.g. internal ohmic values or float current) against the station battery baseline. -or- Verify that the station battery can perform as manufactured by conducting a performance or modified performance capacity test of the entire battery bank.

Table 1-4(c) Component Type – Protection System Station dc Supply Using Nickel-Cadmium (NiCad) Batteries Excluding distributed UFLS and distributed UVLS (see Table 3)		
Protection System Station dc supply used only for non-BES interrupting devices for RAS, non-distributed UFLS system, or non-distributed UVLS systems is excluded (see Table 1-4(e)).		
Component Attributes	Maximum Maintenance Interval	Maintenance Activities
Protection System Station dc supply Nickel-Cadmium (NiCad) batteries not having monitoring attributes of Table 1-4(f).	4 Calendar Months	Verify: <ul style="list-style-type: none"> • Station dc supply voltage Inspect: <ul style="list-style-type: none"> • Electrolyte level • For unintentional grounds
	18 Calendar Months	Verify: <ul style="list-style-type: none"> • Float voltage of battery charger • Battery continuity • Battery terminal connection resistance • Battery intercell or unit-to-unit connection resistance Inspect: <ul style="list-style-type: none"> • Cell condition of all individual battery cells. • Physical condition of battery rack

Table 1-4(c) Component Type – Protection System Station dc Supply Using Nickel-Cadmium (NiCad) Batteries Excluding distributed UFLS and distributed UVLS (see Table 3)		
Protection System Station dc supply used only for non-BES interrupting devices for RAS, non-distributed UFLS system, or non-distributed UVLS systems is excluded (see Table 1-4(e)).		
Component Attributes	Maximum Maintenance Interval	Maintenance Activities
	6 Calendar Years	Verify that the station battery can perform as manufactured by conducting a performance or modified performance capacity test of the entire battery bank.

Table 1-4(d) Component Type – Protection System Station dc Supply Using Non Battery Based Energy Storage Excluding distributed UFLS and distributed UVLS (see Table 3)		
Protection System Station dc supply used only for non-BES interrupting devices for RAS, non-distributed UFLS system, or non-distributed UVLS systems is excluded (see Table 1-4(e)).		
Component Attributes	Maximum Maintenance Interval	Maintenance Activities
Any Protection System station dc supply not using a battery and not having monitoring attributes of Table 1-4(f).	4 Calendar Months	Verify: <ul style="list-style-type: none"> • Station dc supply voltage Inspect: <ul style="list-style-type: none"> • For unintentional grounds
	18 Calendar Months	Inspect: Condition of non-battery based dc supply
	6 Calendar Years	Verify that the dc supply can perform as manufactured when ac power is not present.

Table 1-4(e) Component Type – Protection System Station dc Supply for non-BES Interrupting Devices for RAS, non-distributed UFLS, and non-distributed UVLS systems		
Component Attributes	Maximum Maintenance Interval	Maintenance Activities
Any Protection System dc supply used for tripping only non-BES interrupting devices as part of a RAS, non-distributed UFLS, or non-distributed UVLS system and not having monitoring attributes of Table 1-4(f).	When control circuits are verified (See Table 1-5)	Verify Station dc supply voltage.

Table 1-4(f) Exclusions for Protection System Station dc Supply Monitoring Devices and Systems		
Component Attributes	Maximum Maintenance Interval	Maintenance Activities
Any station dc supply with high and low voltage monitoring and alarming of the battery charger voltage to detect charger overvoltage and charger failure (See Table 2).	No periodic maintenance specified	No periodic verification of station dc supply voltage is required.
Any battery based station dc supply with electrolyte level monitoring and alarming in every cell (See Table 2).		No periodic inspection of the electrolyte level for each cell is required.
Any station dc supply with unintentional dc ground monitoring and alarming (See Table 2).		No periodic inspection of unintentional dc grounds is required.
Any station dc supply with charger float voltage monitoring and alarming to ensure correct float voltage is being applied on the station dc supply (See Table 2).		No periodic verification of float voltage of battery charger is required.
Any battery based station dc supply with monitoring and alarming of battery string continuity (See Table 2).		No periodic verification of the battery continuity is required.
Any battery based station dc supply with monitoring and alarming of the intercell and/or terminal connection detail resistance of the entire battery (See Table 2).		No periodic verification of the intercell and terminal connection resistance is required.
Any Valve Regulated Lead-Acid (VRLA) or Vented Lead-Acid (VLA) station battery with internal ohmic value or float current monitoring and alarming, and evaluating present values relative to baseline internal ohmic values for every cell/unit (See Table 2).		No periodic evaluation relative to baseline of battery cell/unit measurements indicative of battery performance is required to verify the station battery can perform as manufactured.
Any Valve Regulated Lead-Acid (VRLA) or Vented Lead-Acid (VLA) station battery with monitoring and alarming of each cell/unit internal ohmic value (See Table 2).		No periodic inspection of the condition of all individual units by measuring battery cell/unit internal ohmic values of a station VRLA or Vented Lead-Acid (VLA) battery is required.

Table 1-5 Component Type - Control Circuitry Associated With Protective Functions Excluding distributed UFLS and distributed UVLS (see Table 3), Automatic Reclosing (see Table 4), and Sudden Pressure Relaying (see Table 5) Note: Table requirements apply to all Control Circuitry Components of Protection Systems, and RAS except as noted.		
Component Attributes	Maximum Maintenance Interval	Maintenance Activities
Trip coils or actuators of circuit breakers, interrupting devices, or mitigating devices (regardless of any monitoring of the control circuitry).	6 Calendar Years	Verify that each trip coil is able to operate the circuit breaker, interrupting device, or mitigating device.
Electromechanical lockout devices which are directly in a trip path from the protective relay to the interrupting device trip coil (regardless of any monitoring of the control circuitry).	6 Calendar Years	Verify electrical operation of electromechanical lockout devices.
Unmonitored control circuitry associated with RAS. (See Table 4-2(b) for RAS which include Automatic Reclosing.)	12 Calendar Years	Verify all paths of the control circuits essential for proper operation of the RAS.
Unmonitored control circuitry associated with protective functions inclusive of all auxiliary relays.	12 Calendar Years	Verify all paths of the trip circuits inclusive of all auxiliary relays through the trip coil(s) of the circuit breakers or other interrupting devices.
Control circuitry associated with protective functions and/or RAS whose integrity is monitored and alarmed (See Table 2).	No periodic maintenance specified	None.

<p align="center">Table 2 – Alarming Paths and Monitoring</p> <p align="center">In Tables 1-1 through 1-5, Table 3, Tables 4-1 through 4-23, and Table 5 alarm attributes used to justify extended maximum maintenance intervals and/or reduced maintenance activities are subject to the following maintenance requirements</p>		
Component Attributes	Maximum Maintenance Interval	Maintenance Activities
<p>Any alarm path through which alarms in Tables 1-1 through 1-5, Table 3, Tables 4-1 through 4-23, and Table 5 are conveyed from the alarm origin to the location where corrective action can be initiated, and not having all the attributes of the “Alarm Path with monitoring” category below.</p> <p>Alarms are reported within 24 hours of detection to a location where corrective action can be initiated.</p>	12 Calendar Years	Verify that the alarm path conveys alarm signals to a location where corrective action can be initiated.
<p>Alarm Path with monitoring:</p> <p>The location where corrective action is taken receives an alarm within 24 hours for failure of any portion of the alarming path from the alarm origin to the location where corrective action can be initiated.</p>	No periodic maintenance specified	None.

Table 3 Maintenance Activities and Intervals for distributed UFLS and distributed UVLS Systems		
Component Attributes	Maximum Maintenance Interval	Maintenance Activities
Any unmonitored protective relay not having all the monitoring attributes of a category below.	6 Calendar Years	Verify that settings are as specified. For non-microprocessor relays: <ul style="list-style-type: none"> • Test and, if necessary calibrate. For microprocessor relays: <ul style="list-style-type: none"> • Verify operation of the relay inputs and outputs that are essential to proper functioning of the Protection System. • Verify acceptable measurement of power system input values.
Monitored microprocessor protective relay with the following: <ul style="list-style-type: none"> • Internal self-diagnosis and alarming (See Table 2). • Voltage and/or current waveform sampling three or more times per power cycle, and conversion of samples to numeric values for measurement calculations by microprocessor electronics. Alarming for power supply failure (See Table 2).	12 Calendar Years	Verify: <ul style="list-style-type: none"> • Settings are as specified. • Operation of the relay inputs and outputs that are essential to proper functioning of the Protection System. • Acceptable measurement of power system input values.
Monitored microprocessor protective relay with preceding row attributes and the following: <ul style="list-style-type: none"> • <u>A_cAC</u> measurements are continuously verified by comparison to an independent ac measurement source, with alarming for excessive error (See Table 2). 	12 Calendar Years	Verify only the unmonitored relay inputs and outputs that are essential to proper functioning of the Protection System.

Table 3 Maintenance Activities and Intervals for distributed UFLS and distributed UVLS Systems		
Component Attributes	Maximum Maintenance Interval	Maintenance Activities
<ul style="list-style-type: none"> Some or all binary or status inputs and control outputs are monitored by a process that continuously demonstrates ability to perform as designed, with alarming for failure (See Table 2). Alarming for change of settings (See Table 2).		
Voltage and/or current sensing devices associated with UFLS or UVLS systems.	12 Calendar Years	Verify that current and/or voltage signal values are provided to the protective relays.
Protection System dc supply for tripping non-BES interrupting devices used only for a UFLS or UVLS system.	12 Calendar Years	Verify Protection System dc supply voltage.
Control circuitry between the UFLS or UVLS relays and electromechanical lockout and/or tripping auxiliary devices (excludes non-BES interrupting device trip coils).	12 Calendar Years	Verify the path from the relay to the lockout and/or tripping auxiliary relay (including essential supervisory logic).
Electromechanical lockout and/or tripping auxiliary devices associated only with UFLS or UVLS systems (excludes non-BES interrupting device trip coils).	12 Calendar Years	Verify electrical operation of electromechanical lockout and/or tripping auxiliary devices.
Control circuitry between the electromechanical lockout and/or tripping auxiliary devices and the non-BES interrupting devices in UFLS or UVLS systems, or between UFLS or UVLS relays (with no interposing electromechanical lockout or auxiliary device) and the non-BES interrupting devices (excludes non-BES interrupting device trip coils).	No periodic maintenance specified	None.
Trip coils of non-BES interrupting devices in UFLS or UVLS systems.	No periodic maintenance specified	None.

Table 4-1 Maintenance Activities and Intervals for Automatic Reclosing Components Component Type – Reclosing <u>and Supervisory</u> Relay		
Note: In cases where Components of Automatic Reclosing are common to Components listed in Table 1-1 through 1-5, the Components only need to be tested once during a distinct maintenance interval.		
Component Attributes	Maximum Maintenance Interval	Maintenance Activities
Any unmonitored reclosing relay <u>or supervisory relay</u> not having all the monitoring attributes of a category below.	6 Calendar Years	Verify that settings are as specified. For non-microprocessor <u>reclosing or supervisory</u> relays: <ul style="list-style-type: none"> • Test and, if necessary calibrate For microprocessor <u>reclosing or supervisory</u> relays: <ul style="list-style-type: none"> • <u>Verify operation of the relay inputs and outputs that are essential to proper functioning of the Automatic Reclosing.</u> <u>For microprocessor supervisory relays:</u> <ul style="list-style-type: none"> • <u>Verify acceptable measurement of power system input values.</u>
Monitored microprocessor reclosing relay <u>or supervisory relay</u> with the following: <ul style="list-style-type: none"> • Internal self-diagnosis and alarming (See Table 2). • Alarming for power supply failure (See Table 2). <u>For supervisory relay:</u> <ul style="list-style-type: none"> • <u>Voltage waveform sampling three or more times per power cycle, and conversion of samples to numeric values for measurement calculations by microprocessor electronics.</u> 	12 Calendar Years	Verify: <ul style="list-style-type: none"> • Settings are as specified. • Operation of the relay inputs and outputs that are essential to proper functioning of the Automatic Reclosing. <u>For supervisory relays:</u> <ul style="list-style-type: none"> • <u>Verify acceptable measurement of power system input values.</u>

Table 4-1

Maintenance Activities and Intervals for Automatic Reclosing Components

Component Type – Reclosing and Supervisory Relay

Note: In cases where Components of Automatic Reclosing are common to Components listed in Table 1-1 through 1-5, the Components only need to be tested once during a distinct maintenance interval.

Component Attributes	Maximum Maintenance Interval	Maintenance Activities
<p><u>Monitored microprocessor reclosing relay or supervisory relay with preceding row attributes and the following:</u></p> <ul style="list-style-type: none"> • <u>-Some or all binary or status inputs and control outputs are monitored by a process that continuously demonstrates ability to perform as designed, with alarming for failure (See Table 2).</u> • <u>Alarming for change of settings (See Table 2).</u> <p><u>For supervisory relay:</u></p> <ul style="list-style-type: none"> • <u>Ac measurements are continuously verified by comparison to an independent ac measurement source, with alarming for excessive error (See Table 2).</u> 	<p><u>12 Calendar Years</u></p>	<p><u>Verify only the unmonitored relay inputs and outputs that are essential to proper functioning of the Automatic Reclosing.</u></p>

Table 4-2(a)

Maintenance Activities and Intervals for Automatic Reclosing Components

Component Type – Control Circuitry Associated with Reclosing and Supervisory Relays that are NOT an Integral Part of an RAS

Note: In cases where Components of Automatic Reclosing are common to Components listed in Table 1-5, the Components only need to be tested once during a distinct maintenance interval.

Component Attributes	Maximum Maintenance Interval	Maintenance Activities
Unmonitored Control circuitry associated with Automatic Reclosing that is not an integral part of an RAS.	12 Calendar Years	Verify that Automatic Reclosing, upon initiation, does not issue a premature closing command to the close circuitry.
Control circuitry associated with Automatic Reclosing that is not part of an RAS and is monitored and alarmed for conditions that would result in a premature closing command. (See Table 2)	No periodic maintenance specified	None.

Table 4-2(b)

Maintenance Activities and Intervals for Automatic Reclosing Components

Component Type – Control Circuitry Associated with Reclosing and Supervisory Relays that ARE an Integral Part of an RAS

Note: In cases where Components of Automatic Reclosing are common to Components listed in Table 1-5, the Components only need to be tested once during a distinct maintenance interval.

Component Attributes	Maximum Maintenance Interval	Maintenance Activities
Close coils or actuators of circuit breakers or similar devices that are used in conjunction with Automatic Reclosing as part of an RAS (regardless of any monitoring of the control circuitry).	6 Calendar Years	Verify that each close coil or actuator is able to operate the circuit breaker or mitigating device.
Unmonitored close control circuitry associated with Automatic Reclosing used as an integral part of an RAS.	12 Calendar Years	Verify all paths of the control circuits associated with Automatic Reclosing that are essential for proper operation of the RAS.
Control circuitry associated with Automatic Reclosing that is an integral part of an RAS whose integrity is monitored and alarmed. (See Table 2)	No periodic maintenance specified	None.

Table 4-3

Maintenance Activities and Intervals for Automatic Reclosing Components

Component Type – Voltage Sensing Devices Associated with Supervisory Relays

Note: In cases where Components of Automatic Reclosing are common to Components listed in Table 1-3, the Components only need to be tested once during a distinct maintenance interval.

<u>Component Attributes</u>	<u>Maximum Maintenance Interval</u>	<u>Maintenance Activities</u>
<u>Any voltage sensing devices not having monitoring attributes of the category below.</u>	<u>12 Calendar Years</u>	<u>Verify that voltage signal values are provided to the supervisory relays.</u>
<u>Voltage sensing devices that are connected to microprocessor supervisory relays with ac measurements that are continuously verified by comparison of sensing input value, as measured by the microprocessor relay, to an independent ac measurement source, with alarming for unacceptable error or failure. (See Table 2)</u>	<u>No periodic maintenance specified</u>	<u>None.</u>

<p style="text-align: center;">Table 5 Maintenance Activities and Intervals for Sudden Pressure Relaying</p>		
<p style="text-align: center;">Note: In cases where Components of Sudden Pressure Relaying are common to Components listed in Table 1-5, the Components only need to be tested once during a distinct maintenance interval.</p>		
Component Attributes	Maximum Maintenance Interval	Maintenance Activities
Any fault pressure relay.	6 Calendar Years	Verify the pressure or flow sensing mechanism is operable.
Electromechanical lockout devices which are directly in a trip path from the fault pressure relay to the interrupting device trip coil (regardless of any monitoring of the control circuitry).	6 Calendar Years	Verify electrical operation of electromechanical lockout devices.
Unmonitored control circuitry associated with Sudden Pressure Relaying.	12 Calendar Years	Verify all paths of the trip circuits inclusive of all auxiliary relays through the trip coil(s) of the circuit breakers or other interrupting devices.
Control circuitry associated with Sudden Pressure Relaying whose integrity is monitored and alarmed (See Table 2).	No periodic maintenance specified	None.

PRC-005 — Attachment A

Criteria for a Performance-Based Protection System Maintenance Program

Purpose: To establish a technical basis for initial and continued use of a performance-based Protection System Maintenance Program (PSMP).

To establish the technical justification for the initial use of a performance-based PSMP:

1. Develop a list with a description of Components included in each designated Segment, with a minimum Segment population of 60 Components.
2. Maintain the Components in each Segment according to the time-based maximum allowable intervals established in Tables 1-1 through 1-5, Table 3, Tables 4-1 through 4-~~23~~, and Table 5 until results of maintenance activities for the Segment are available for a minimum of 30 individual Components of the Segment.
3. Document the maintenance program activities and results for each Segment, including maintenance dates and Countable Events for each included Component.
4. Analyze the maintenance program activities and results for each Segment to determine the overall performance of the Segment and develop maintenance intervals.
5. Determine the maximum allowable maintenance interval for each Segment such that the Segment experiences Countable Events on no more than 4% of the Components within the Segment, for the greater of either the last 30 Components maintained or all Components maintained in the previous year.

To maintain the technical justification for the ongoing use of a performance-based PSMP:

1. At least annually, update the list of Components and Segments and/or description if any changes occur within the Segment.
2. Perform maintenance on the greater of 5% of the Components (addressed in the performance based PSMP) in each Segment or 3 individual Components within the Segment in each year.
3. For the prior year, analyze the maintenance program activities and results for each Segment to determine the overall performance of the Segment.
4. Using the prior year's data, determine the maximum allowable maintenance interval for each Segment such that the Segment experiences Countable Events on no more than 4% of the Components within the Segment, for the greater of either the last 30 Components maintained or all Components maintained in the previous year.

If the Components in a Segment maintained through a performance-based PSMP experience 4% or more Countable Events, develop, document, and implement an action plan to reduce the Countable Events to less than 4% of the Segment population within 3 years.

Rationale:

During development of this standard, text boxes were embedded within the standard to explain the rationale for various parts of the standard. Upon BOT approval, the text from the rationale text boxes was moved to this section.

Rationale for Applicability Section:

~~This section does not reflect the applicability changes that will be proposed by the Project 2014-01 Standards Applicability for Dispersed Generation Resources standards drafting team. The changes in this posted version and those being made by the Project 2014-01 standards drafting team do not overlap.~~

~~Additionally, to align with ongoing NERC standards development in Project 2010-05.2: Special Protection Systems, the term “Special Protection Systems” in PRC 005-4 was replaced by the term “Remedial Action Schemes.” These terms are synonymous in the NERC Glossary of Terms.~~

Rationale for the deletion of part of the definition of Component:

~~The SDT determined that it was explanatory in nature and adequately addressed in the Supplementary Reference and FAQ Document.~~

Rationale for R3 Part 3.1:

~~In the last posting, the SDT included language in the standard that was originally in the implementation plan that required completion of maintenance activities within three years for newly identified Automatic Reclosing Components following a notification under Requirement R6, which has been removed. After further discussion, the SDT determined that a separate shorter timeframe for maintenance of newly identified Automatic Reclosing Components created unnecessary complication within the standard. The SDT agreed that entities should be responsible for maintaining the Automatic Reclosing Components subject to the standard, whether existing, newly added or newly within scope based on a change in the largest generating unit in the BA or, if a member of a Reserve Sharing Group, the largest generating unit within the Reserve Sharing Group according to the timeframes in the maintenance tables. Therefore, 3.1 and its subparts have been removed and have not been reinserted into the implementation plan.~~

Rationale for R4 Part 4.1:

~~In the last posting, the SDT included language in the standard that was originally in the implementation plan that required completion of maintenance activities within three years for newly identified Automatic Reclosing Components following a notification under Requirement R6, which has been removed. After further discussion, the SDT determined that a separate shorter timeframe for maintenance of newly identified Automatic Reclosing Components created unnecessary complication within the standard. The SDT agreed that entities should be responsible for maintaining the Automatic Reclosing Components subject to the standard, whether existing, newly added or newly within scope based on a change in the largest generating unit in the BA or, if a member of a Reserve Sharing Group, the largest generating~~

~~unit within the Reserve Sharing Group according to the timeframes in the maintenance tables. Therefore, 4.1 and its subparts have been removed and have not been reinserted into the implementation plan.~~

~~Rationale for section 4.2.5:~~

~~These applicability revisions are intended to clarify and provide for consistent application of the Requirements to BES generator Facilities included in the BES through Inclusion 14 — Dispersed Power Producing Resources. The SDT modified the language for clarity based on comments received and is not changing the intent of the standard modification from the last posted version of this standard.~~

Rationale for revisions to Automatic Reclosing:

To address directives from FERC Order No. 803 addressing Automatic Reclosing, the definition for Automatic Reclosing was revised to add supervisory relays, the associated voltage sensing devices, and the associated control circuitry.

Rationale for revisions to Component Type:

With the revision of the definition of Automatic Reclosing, there are four specific elements of this definition, rather than two as stated in the prior version.

Exhibit A-2

Alternative Proposed Reliability Standard PRC-005-5 (Clean and Redline [PRC-005-5 to PRC-005-4])

Clean Version

Reliability Standard PRC-005-5

A. Introduction

1. **Title:** Protection System, Automatic Reclosing, and Sudden Pressure Relaying Maintenance
2. **Number:** PRC-005-5
3. **Purpose:** To document and implement programs for the maintenance of all Protection Systems, Automatic Reclosing, and Sudden Pressure Relaying affecting the reliability of the Bulk Electric System (BES) so that they are kept in working order.
4. **Applicability:**
 - 4.1. **Functional Entities:**
 - 4.1.1 Transmission Owner
 - 4.1.2 Generator Owner
 - 4.1.3 Distribution Provider
 - 4.2. **Facilities:**
 - 4.2.1 Protection Systems and Sudden Pressure Relaying that are installed for the purpose of detecting Faults on BES Elements (lines, buses, transformers, etc.)
 - 4.2.2 Protection Systems used for underfrequency load-shedding systems installed per ERO underfrequency load-shedding requirements.
 - 4.2.3 Protection Systems used for undervoltage load-shedding systems installed to prevent system voltage collapse or voltage instability for BES reliability.
 - 4.2.4 Protection Systems installed as a Remedial Action Scheme (RAS) for BES reliability.
 - 4.2.5 Protection Systems and Sudden Pressure Relaying for generator Facilities that are part of the BES, except for generators identified through Inclusion I4 of the BES definition, including:
 - 4.2.5.1 Protection Systems that act to trip the generator either directly or via lockout or auxiliary tripping relays.
 - 4.2.5.2 Protection Systems and Sudden Pressure Relaying for generator step-up transformers for generators that are part of the BES.
 - 4.2.5.3 Protection Systems and Sudden Pressure Relaying for station service or excitation transformers connected to the generator bus of generators which are part of the BES, that act to trip the generator either directly or via lockout or tripping auxiliary relays.

4.2.6 Protection Systems and Sudden Pressure Relaying for the following BES generator Facilities for dispersed power producing resources identified through Inclusion I4 of the BES definition:

4.2.6.1 Protection Systems and Sudden Pressure Relaying for Facilities used in aggregating dispersed BES generation from the point where those resources aggregate to greater than 75 MVA to a common point of connection at 100kV or above.

4.2.7 Automatic Reclosing¹, including:

4.2.7.1 Automatic Reclosing applied on the terminals of Elements connected to the BES bus located at generating plant substations where the total installed gross generating plant capacity is greater than the gross capacity of the largest BES generating unit within the Balancing Authority Area or, if a member of a Reserve Sharing Group, the largest generating unit within the Reserve Sharing Group.²

4.2.7.2 Automatic Reclosing applied on the terminals of all BES Elements at substations one bus away from generating plants specified in Section 4.2.7.1 when the substation is less than 10 circuit-miles from the generating plant substation.

4.2.7.3 Automatic Reclosing applied as an integral part of an RAS specified in Section 4.2.4.

5. Effective Date: See the Implementation Plan for this standard.

6. Definitions Used in this Standard:

Automatic Reclosing – Includes the following Components:

- Reclosing relay
- Control circuitry associated with the reclosing relay.

Sudden Pressure Relaying – A system that trips an interrupting device(s) to isolate the equipment it is monitoring and includes the following Components:

- Fault pressure relay – a mechanical relay or device that detects rapid changes in gas pressure, oil pressure, or oil flow that are indicative of Faults within liquid-filled, wire-wound equipment

¹ Automatic Reclosing addressed in Section 4.2.7.1 and 4.2.7.2 may be excluded if the equipment owner can demonstrate that a close-in three-phase fault present for twice the normal clearing time (capturing a minimum trip-close-trip time delay) does not result in a total loss of gross generation in the Interconnection exceeding the gross capacity of the largest relevant BES generating unit where the Automatic Reclosing is applied.

² The largest BES generating unit within the Balancing Authority Area or the largest generating unit within the Reserve Sharing Group, as applicable, is subject to change. As a result of such a change, the Automatic Reclosing Components subject to the standard could change effective on the date of such change.

- Control circuitry associated with a fault pressure relay

Unresolved Maintenance Issue – A deficiency identified during a maintenance activity that causes the Component to not meet the intended performance, cannot be corrected during the maintenance interval, and requires follow-up corrective action.

Segment – Components of a consistent design standard, or a particular model or type from a single manufacturer that typically share other common elements. Consistent performance is expected across the entire population of a Segment. A Segment must contain at least sixty (60) individual Components.

Component Type –

- Any one of the five specific elements of a Protection System.
- Any one of the two specific elements of Automatic Reclosing.
- Any one of the two specific elements of Sudden Pressure Relaying.

Component – Any individual discrete piece of equipment included in a Protection System, Automatic Reclosing, or Sudden Pressure Relaying.

Countable Event – A failure of a Component requiring repair or replacement, any condition discovered during the maintenance activities in Tables 1-1 through 1-5, Table 3, Tables 4-1 through 4-2, and Table 5, which requires corrective action or a Protection System Misoperation attributed to hardware failure or calibration failure.

Misoperations due to product design errors, software errors, relay settings different from specified settings, Protection System Component, Automatic Reclosing, or Sudden Pressure Relaying configuration or application errors are not included in Countable Events.

B. Requirements and Measures

- R1.** Each Transmission Owner, Generator Owner, and Distribution Provider shall establish a Protection System Maintenance Program (PSMP) for its Protection Systems, Automatic Reclosing, and Sudden Pressure Relaying identified in Section 4.2, Facilities. *[Violation Risk Factor: Medium] [Time Horizon: Operations Planning]*

The PSMP shall:

- 1.1.** Identify which maintenance method (time-based, performance-based per PRC-005 Attachment A, or a combination) is used to address each Protection System, Automatic Reclosing, and Sudden Pressure Relaying Component Type. All batteries associated with the station dc supply Component Type of a Protection System shall be included in a time-based program as described in Table 1-4 and Table 3.
- 1.2.** Include the applicable monitored Component attributes applied to each Protection System, Automatic Reclosing, and Sudden Pressure Relaying Component Type consistent with the maintenance intervals specified in Tables 1-1 through 1-5, Table 2, Table 3, Table 4-1 through 4-2, and Table 5 where

monitoring is used to extend the maintenance intervals beyond those specified for unmonitored Protection System, Automatic Reclosing, and Sudden Pressure Relaying Components.

- M1.** Each Transmission Owner, Generator Owner and Distribution Provider shall have a documented Protection System Maintenance Program in accordance with Requirement R1.

For each Protection System, Automatic Reclosing, and Sudden Pressure Relaying Component Type, the documentation shall include the type of maintenance method applied (time-based, performance-based, or a combination of these maintenance methods), and shall include all batteries associated with the station dc supply Component Types in a time-based program as described in Table 1-4 and Table 3. (Part 1.1)

For Component Types that use monitoring to extend the maintenance intervals, the responsible entity(s) shall have evidence for each Protection System, Automatic Reclosing, and Sudden Pressure Relaying Component Type (such as manufacturer's specifications or engineering drawings) of the appropriate monitored Component attributes as specified in Tables 1-1 through 1-5, Table 2, Table 3, Table 4-1 through 4-2, and Table 5. (Part 1.2)

- R2.** Each Transmission Owner, Generator Owner, and Distribution Provider that uses performance-based maintenance intervals in its PSMP shall follow the procedure established in PRC-005 Attachment A to establish and maintain its performance-based intervals. *[Violation Risk Factor: Medium] [Time Horizon: Operations Planning]*
- M2.** Each Transmission Owner, Generator Owner, and Distribution Provider that uses performance-based maintenance intervals shall have evidence that its current performance-based maintenance program(s) is in accordance with Requirement R2, which may include, but is not limited to, Component lists, dated maintenance records, and dated analysis records and results.
- R3.** Each Transmission Owner, Generator Owner, and Distribution Provider that utilizes time-based maintenance program(s) shall maintain its Protection System, Automatic Reclosing, and Sudden Pressure Relaying Components that are included within the time-based maintenance program in accordance with the minimum maintenance activities and maximum maintenance intervals prescribed within Tables 1-1 through 1-5, Table 2, Table 3, Table 4-1 through 4-2, and Table 5. *[Violation Risk Factor: High] [Time Horizon: Operations Planning]*
- M3.** Each Transmission Owner, Generator Owner, and Distribution Provider that utilizes time-based maintenance program(s) shall have evidence that it has maintained its Protection System, Automatic Reclosing, and Sudden Pressure Relaying Components included within its time-based program in accordance with Requirement R3. The evidence may include, but is not limited to, dated maintenance records, dated maintenance summaries, dated check-off lists, dated inspection records, or dated work orders.

- R4.** Each Transmission Owner, Generator Owner, and Distribution Provider that utilizes performance-based maintenance program(s) in accordance with Requirement R2 shall implement and follow its PSMP for its Protection System, Automatic Reclosing, and Sudden Pressure Relaying Components that are included within the performance-based program(s). *[Violation Risk Factor: High] [Time Horizon: Operations Planning]*
- M4.** Each Transmission Owner, Generator Owner, and Distribution Provider that utilizes performance-based maintenance intervals in accordance with Requirement R2 shall have evidence that it has implemented the Protection System Maintenance Program for the Protection System, Automatic Reclosing, and Sudden Pressure Relaying Components included in its performance-based program in accordance with Requirement R4. The evidence may include, but is not limited to, dated maintenance records, dated maintenance summaries, dated check-off lists, dated inspection records, or dated work orders.
- R5.** Each Transmission Owner, Generator Owner, and Distribution Provider shall demonstrate efforts to correct identified Unresolved Maintenance Issues. *[Violation Risk Factor: Medium] [Time Horizon: Operations Planning]*
- M5.** Each Transmission Owner, Generator Owner, and Distribution Provider shall have evidence that it has undertaken efforts to correct identified Unresolved Maintenance Issues in accordance with Requirement R5. The evidence may include, but is not limited to, work orders, replacement Component orders, invoices, project schedules with completed milestones, return material authorizations (RMAs) or purchase orders.

C. Compliance

1. Compliance Monitoring Process

1.1. Compliance Enforcement Authority

As defined in the NERC Rules of Procedure, “Compliance Enforcement Authority” means NERC or the Regional Entity in their respective roles of monitoring and enforcing compliance with the NERC Reliability Standards.

1.2. Evidence Retention

The following evidence retention periods identify the period of time an entity is required to retain specific evidence to demonstrate compliance. For instances where the evidence retention period specified below is shorter than the time since the last audit, the Compliance Enforcement Authority may ask an entity to provide other evidence to show that it was compliant for the full time period since the last audit.

The Transmission Owner, Generator Owner, and Distribution Provider shall each keep data or evidence to show compliance as identified below unless

directed by its Compliance Enforcement Authority to retain specific evidence for a longer period of time as part of an investigation.

For Requirement R1, the Transmission Owner, Generator Owner, and Distribution Provider shall each keep its current dated Protection System Maintenance Program, as well as any superseded versions since the preceding compliance audit, including the documentation that specifies the type of maintenance program applied for each Protection System, Automatic Reclosing, or Sudden Pressure Relaying Component Type.

For Requirement R2, Requirement R3, and Requirement R4, in cases where the interval of the maintenance activity is longer than the audit cycle, the Transmission Owner, Generator Owner, and Distribution Provider shall each keep documentation of the most recent performance of that maintenance activity for the Protection System, Automatic Reclosing, or Sudden Pressure Relaying Component. In cases where the interval of the maintenance activity is shorter than the audit cycle, documentation of all performances (in accordance with the tables) of that maintenance activity for the Protection System, Automatic Reclosing, or Sudden Pressure Relaying Component since the previous scheduled audit date shall be retained.

For Requirement R5 the Transmission Owner, Generator Owner, and Distribution Provider shall each keep documentation of Unresolved Maintenance Issues identified by the entity since the last audit, including all that were resolved since the last audit.

The Compliance Enforcement Authority shall keep the last audit records and all requested and submitted subsequent audit records.

1.3. Compliance Monitoring and Assessment Processes:

- Compliance Audits
- Self-Certifications
- Spot Checking
- Compliance Violation Investigations
- Self-Reporting
- Complaints

1.4. Additional Compliance Information

None

Table of Compliance Elements

Requirement Number	Lower VSL	Moderate VSL	High VSL	Severe VSL
R1.	The entity’s PSMP failed to specify whether one Component Type is being addressed by time-based or performance-based maintenance, or a combination of both (Part 1.1).	The entity’s PSMP failed to specify whether two Component Types are being addressed by time-based or performance-based maintenance, or a combination of both (Part 1.1).	<p>The entity’s PSMP failed to specify whether three Component Types are being addressed by time-based or performance-based maintenance, or a combination of both. (Part 1.1).</p> <p style="text-align: center;">OR</p> <p>The entity’s PSMP failed to include the applicable monitoring attributes applied to each Component Type consistent with the maintenance intervals specified in Tables 1-1 through 1-5, Table 2, Table 3, Tables 4-1 through 4-2, and Table 5 where monitoring is used to extend the maintenance intervals beyond those specified for unmonitored Components (Part 1.2).</p>	<p>The entity failed to establish a PSMP.</p> <p style="text-align: center;">OR</p> <p>The entity’s PSMP failed to specify whether four or more Component Types are being addressed by time-based or performance-based maintenance, or a combination of both (Part 1.1).</p> <p style="text-align: center;">OR</p> <p>The entity’s PSMP failed to include applicable station batteries in a time-based program (Part 1.1).</p>
R2.	The entity uses performance-based maintenance intervals in its PSMP but failed to reduce Countable Events to no more than 4% within three years.	NA	The entity uses performance-based maintenance intervals in its PSMP but failed to reduce Countable Events to no more than 4% within four years.	<p>The entity uses performance-based maintenance intervals in its PSMP but:</p> <ol style="list-style-type: none"> 1) Failed to establish the technical justification described within Requirement R2 for the initial use of the performance-based PSMP <p style="text-align: center;">OR</p> <ol style="list-style-type: none"> 2) Failed to reduce Countable Events to no more than 4% within five years <p style="text-align: center;">OR</p>

Requirement Number	Lower VSL	Moderate VSL	High VSL	Severe VSL
				3) Maintained a Segment with less than 60 Components OR 4) Failed to: <ul style="list-style-type: none"> • Annually update the list of Components, OR • Annually perform maintenance on the greater of 5% of the Segment population or 3 Components, OR • Annually analyze the program activities and results for each Segment.
R3.	For Components included within a time-based maintenance program, the entity failed to maintain 5% or less of the total Components included within a specific Component Type in accordance with the minimum maintenance activities and maximum maintenance intervals prescribed within Tables 1-1 through 1-5, Table 2, Table 3, Tables 4-1 through 4-2, and Table 5.	For Components included within a time-based maintenance program, the entity failed to maintain more than 5% but 10% or less of the total Components included within a specific Component Type in accordance with the minimum maintenance activities and maximum maintenance intervals prescribed within Tables 1-1 through 1-5, Table 2, Table 3, Tables 4-1 through 4-2, and Table 5.	For Components included within a time-based maintenance program, the entity failed to maintain more than 10% but 15% or less of the total Components included within a specific Component Type in accordance with the minimum maintenance activities and maximum maintenance intervals prescribed within Tables 1-1 through 1-5, Table 2, Table 3, Tables 4-1 through 4-2, and Table 5.	For Components included within a time-based maintenance program, the entity failed to maintain more than 15% of the total Components included within a specific Component Type in accordance with the minimum maintenance activities and maximum maintenance intervals prescribed within Tables 1-1 through 1-5, Table 2, Table 3, Tables 4-1 through 4-2, and Table 5.

Requirement Number	Lower VSL	Moderate VSL	High VSL	Severe VSL
R4.	For Components included within a performance-based maintenance program, the entity failed to maintain 5% or less of the annual scheduled maintenance for a specific Component Type in accordance with their performance-based PSMP.	For Components included within a performance-based maintenance program, the entity failed to maintain more than 5% but 10% or less of the annual scheduled maintenance for a specific Component Type in accordance with their performance-based PSMP.	For Components included within a performance-based maintenance program, the entity failed to maintain more than 10% but 15% or less of the annual scheduled maintenance for a specific Component Type in accordance with their performance-based PSMP.	For Components included within a performance-based maintenance program, the entity failed to maintain more than 15% of the annual scheduled maintenance for a specific Component Type in accordance with their performance-based PSMP.
R5.	The entity failed to undertake efforts to correct 5 or fewer identified Unresolved Maintenance Issues.	The entity failed to undertake efforts to correct greater than 5 but less than or equal to 10 identified Unresolved Maintenance Issues.	The entity failed to undertake efforts to correct greater than 10 but less than or equal to 15 identified Unresolved Maintenance Issues.	The entity failed to undertake efforts to correct greater than 15 identified Unresolved Maintenance Issues.

D. Regional Variances

None.

E. Interpretations

None.

Supplemental Reference Documents

The following documents present a detailed discussion about determination of maintenance intervals and other useful information regarding establishment of a maintenance program.

1. *Supplementary Reference and FAQ - PRC-005-4 Protection System Maintenance*, Protection System Maintenance and Testing Standard Drafting Team (April 2014)
2. *Considerations for Maintenance and Testing of Auto-reclosing Schemes*, NERC System Analysis and Modeling Subcommittee, and NERC System Protection and Control Subcommittee (November 2012)
3. *Sudden Pressure Relays and Other Devices that Respond to Non-Electrical Quantities – SPCS Input for Standard Development in Response to FERC Order No. 758*, NERC System Protection and Control Subcommittee (December 2013)
4. *Sudden Pressure Relays and Other Devices that Respond to Non-Electrical Quantities – Supplemental Information to Support Project 2007-17.3: Protection System Maintenance and Testing* (October 31, 2014)

Version History

Version	Date	Action	Change Tracking
0	February 8, 2005	Adopted by NERC Board of Trustees	New
1	February 7, 2006	Adopted by NERC Board of Trustees	1. Changed incorrect use of certain hyphens (-) to “en dash” (–) and “em dash (—).” 2. Added “periods” to items where appropriate. Changed “Timeframe” to “Time Frame” in item D, 1.2.
1	March 16, 2007	PRC-005-1 Approved by FERC. Docket No. RM06-16-000	

Version	Date	Action	Change Tracking
1a	February 17, 2011	Adopted by NERC Board of Trustees	Added Appendix 1 - Interpretation regarding applicability of standard to protection of radially connected transformers developed in Project 2009-17
1a	September 26, 2011	Approved by FERC. Docket No. RD11-5-000	
1b	November 5, 2009	Adopted by NERC Board of Trustees	Interpretation of R1, R1.1, and R1.2 developed by Project 2009-10
1b	February 3, 2012	FERC Order approving revised definition of "Protection System"	Per footnote 8 of FERC's order, the definition of "Protection System" supersedes interpretation "b" of PRC-005-1b upon the effective date of the modified definition (i.e., April 1, 2013) <i>See N. Amer. Elec. Reliability Corp., 138 FERC ¶ 61,095 (February 3, 2012).</i>
1b	February 3, 2012	PRC-005-1b Approved by FERC. Docket No. RM10-5-000	
1.1b	May 9, 2012	Adopted by NERC Board of Trustees	Errata change developed by Project 2010-07, clarified inclusion of generator interconnection Facility in Generator Owner's responsibility
1.1b	September 19, 2013	PRC-005-1.1b Approved by FERC. Docket No. RM12-16-000	

Version	Date	Action	Change Tracking
2	November 7, 2012	Adopted by NERC Board of Trustees	Project 2007-17 - Complete revision, absorbing maintenance requirements from PRC-005-1.1b, PRC-008-0, PRC-011-0, PRC-017-0
2	October 17, 2013	Approved by NERC Standards Committee	Errata Change: The Standards Committee approved an errata change to the implementation plan for PRC-005-2 to add the phrase “or as otherwise made effective pursuant to the laws applicable to such ERO governmental authorities;” to the second sentence under the “Retirement of Existing Standards” section. (no change to standard version number)
2	December 19, 2013	PRC-005-2 Approved by FERC. Docket No. RM13-7-000	
2	March 7, 2014	Adopted by NERC Board of Trustees	Modified R1 VSL in response to FERC directive (no change to standard version number)
2(i)	November 13, 2014	Adopted by NERC Board of Trustees	Applicability section revised by Project 2014-01 to clarify application of Requirements to BES dispersed power producing resources

Version	Date	Action	Change Tracking
2(i)	May 29, 2015	PRC-005-2(i) Approved by FERC. Docket No. RD15-3-000	
2(ii)	November 13, 2014	Adopted by NERC Board of Trustees	Replaced references to Special Protection System and SPS with Remedial Action Scheme and RAS
3	November 7, 2013	Adopted by the NERC Board of Trustees	Revised to address the FERC directive in Order No. 758 to include Automatic Reclosing in maintenance programs
3	February 12, 2014	Approved by NERC Standards Committee	Errata Change: The Standards Committee approved errata changes to correct capitalization of certain defined terms within the definitions of "Unresolved Maintenance Issue" and "Protection System Maintenance Program". The changes will be reflected in the definitions section of PRC-005-3 for "Unresolved Maintenance Issue" and in the NERC Glossary of Terms for "Protection System Maintenance Program". (no change to standard version number)

Version	Date	Action	Change Tracking
3	March 7, 2014	Adopted by NERC Board of Trustees	Modified R1 VSL in response to FERC directive (no change to standard version number)
3	January 22, 2015	PRC-005-3 Approved by FERC. Docket No. RM14-8-000	
3(i)	November 13, 2014	Adopted by NERC Board of Trustees	Applicability section revised by Project 2014-01 to clarify application of Requirements to BES dispersed power producing resources
3(i)	May 29, 2015	PRC-005-3(i) Approved by FERC. Docket No. RD15-3-000	
3(ii)	November 13, 2014	Adopted by NERC Board of Trustees	Replaced references to Special Protection System and SPS with Remedial Action Scheme and RAS
4	November 13, 2014	Adopted by NERC Board of Trustees	Added Sudden Pressure Relaying in response to FERC Order No. 758
4	September 17, 2015	PRC-005-4 Approved by FERC. Docket No. RM15-9-000	
5	May 7, 2015	Adopted by NERC Board of Trustees	Applicability section revised by Project 2014-01 to clarify application of Requirements to BES dispersed power producing resources

Table 1-1 Component Type - Protective Relay Excluding distributed UFLS and distributed UVLS (see Table 3)		
Component Attributes	Maximum Maintenance Interval ³	Maintenance Activities
Any unmonitored protective relay not having all the monitoring attributes of a category below.	6 Calendar Years	For all unmonitored relays: <ul style="list-style-type: none"> • Verify that settings are as specified For non-microprocessor relays: <ul style="list-style-type: none"> • Test and, if necessary calibrate For microprocessor relays: <ul style="list-style-type: none"> • Verify operation of the relay inputs and outputs that are essential to proper functioning of the Protection System. • Verify acceptable measurement of power system input values.
Monitored microprocessor protective relay with the following: <ul style="list-style-type: none"> • Internal self-diagnosis and alarming (see Table 2). • Voltage and/or current waveform sampling three or more times per power cycle, and conversion of samples to numeric values for measurement calculations by microprocessor electronics. • Alarming for power supply failure (see Table 2). 	12 Calendar Years	Verify: <ul style="list-style-type: none"> • Settings are as specified. • Operation of the relay inputs and outputs that are essential to proper functioning of the Protection System. • Acceptable measurement of power system input values.

³ For the tables in this standard, a calendar year starts on the first day of a new year (January 1) after a maintenance activity has been completed. For the tables in this standard, a calendar month starts on the first day of the first month after a maintenance activity has been completed.

Table 1-1 Component Type - Protective Relay Excluding distributed UFLS and distributed UVLS (see Table 3)		
Component Attributes	Maximum Maintenance Interval³	Maintenance Activities
Monitored microprocessor protective relay with preceding row attributes and the following: <ul style="list-style-type: none"> • Ac measurements are continuously verified by comparison to an independent ac measurement source, with alarming for excessive error (See Table 2). • Some or all binary or status inputs and control outputs are monitored by a process that continuously demonstrates ability to perform as designed, with alarming for failure (See Table 2). • Alarming for change of settings (See Table 2). 	12 Calendar Years	Verify only the unmonitored relay inputs and outputs that are essential to proper functioning of the Protection System.

Table 1-2 Component Type - Communications Systems Excluding distributed UFLS and distributed UVLS (see Table 3)		
Component Attributes	Maximum Maintenance Interval	Maintenance Activities
Any unmonitored communications system necessary for correct operation of protective functions, and not having all the monitoring attributes of a category below.	4 Calendar Months	Verify that the communications system is functional.
	6 Calendar Years	Verify that the communications system meets performance criteria pertinent to the communications technology applied (e.g. signal level, reflected power, or data error rate). Verify operation of communications system inputs and outputs that are essential to proper functioning of the Protection System.
Any communications system with continuous monitoring or periodic automated testing for the presence of the channel function, and alarming for loss of function (See Table 2).	12 Calendar Years	Verify that the communications system meets performance criteria pertinent to the communications technology applied (e.g. signal level, reflected power, or data error rate). Verify operation of communications system inputs and outputs that are essential to proper functioning of the Protection System.
Any communications system with all of the following: <ul style="list-style-type: none"> • Continuous monitoring or periodic automated testing for the performance of the channel using criteria pertinent to the communications technology applied (e.g. signal level, reflected power, or data error rate, and alarming for excessive performance degradation). (See Table 2) • Some or all binary or status inputs and control outputs are monitored by a process that continuously demonstrates ability to perform as designed, with alarming for failure (See Table 2). 	12 Calendar Years	Verify only the unmonitored communications system inputs and outputs that are essential to proper functioning of the Protection System

Table 1-3 Component Type - Voltage and Current Sensing Devices Providing Inputs to Protective Relays Excluding distributed UFLS and distributed UVLS (see Table 3)		
Component Attributes	Maximum Maintenance Interval	Maintenance Activities
Any voltage and current sensing devices not having monitoring attributes of the category below.	12 Calendar Years	Verify that current and voltage signal values are provided to the protective relays.
Voltage and Current Sensing devices connected to microprocessor relays with AC measurements are continuously verified by comparison of sensing input value, as measured by the microprocessor relay, to an independent ac measurement source, with alarming for unacceptable error or failure (see Table 2).	No periodic maintenance specified	None.

Table 1-4(a) Component Type – Protection System Station dc Supply Using Vented Lead-Acid (VLA) Batteries Excluding distributed UFLS and distributed UVLS (see Table 3)		
Protection System Station dc supply used only for non-BES interrupting devices for RAS, non-distributed UFLS systems, or non-distributed UVLS systems is excluded (see Table 1-4(e)).		
Component Attributes	Maximum Maintenance Interval	Maintenance Activities
Protection System Station dc supply using Vented Lead-Acid (VLA) batteries not having monitoring attributes of Table 1-4(f).	4 Calendar Months	Verify: <ul style="list-style-type: none"> • Station dc supply voltage Inspect: <ul style="list-style-type: none"> • Electrolyte level • For unintentional grounds
	18 Calendar Months	Verify: <ul style="list-style-type: none"> • Float voltage of battery charger • Battery continuity • Battery terminal connection resistance • Battery intercell or unit-to-unit connection resistance Inspect: <ul style="list-style-type: none"> • Cell condition of all individual battery cells where cells are visible – or measure battery cell/unit internal ohmic values where the cells are not visible • Physical condition of battery rack

<p style="text-align: center;">Table 1-4(a) Component Type – Protection System Station dc Supply Using Vented Lead-Acid (VLA) Batteries Excluding distributed UFLS and distributed UVLS (see Table 3)</p> <p style="text-align: center;">Protection System Station dc supply used only for non-BES interrupting devices for RAS, non-distributed UFLS systems, or non-distributed UVLS systems is excluded (see Table 1-4(e)).</p>		
Component Attributes	Maximum Maintenance Interval	Maintenance Activities
	18 Calendar Months -or- 6 Calendar Years	Verify that the station battery can perform as manufactured by evaluating cell/unit measurements indicative of battery performance (e.g. internal ohmic values or float current) against the station battery baseline. -or- Verify that the station battery can perform as manufactured by conducting a performance or modified performance capacity test of the entire battery bank.

Table 1-4(b) Component Type – Protection System Station dc Supply Using Valve-Regulated Lead-Acid (VRLA) Batteries Excluding distributed UFLS and distributed UVLS (see Table 3)		
Protection System Station dc supply used only for non-BES interrupting devices for RAS, non-distributed UFLS systems, or non-distributed UVLS systems is excluded (see Table 1-4(e)).		
Component Attributes	Maximum Maintenance Interval	Maintenance Activities
Protection System Station dc supply with Valve Regulated Lead-Acid (VRLA) batteries not having monitoring attributes of Table 1-4(f).	4 Calendar Months	Verify: <ul style="list-style-type: none"> • Station dc supply voltage Inspect: <ul style="list-style-type: none"> • For unintentional grounds
	6 Calendar Months	Inspect: <ul style="list-style-type: none"> • Condition of all individual units by measuring battery cell/unit internal ohmic values.
	18 Calendar Months	Verify: <ul style="list-style-type: none"> • Float voltage of battery charger • Battery continuity • Battery terminal connection resistance • Battery intercell or unit-to-unit connection resistance Inspect: <ul style="list-style-type: none"> • Physical condition of battery rack

<p align="center">Table 1-4(b)</p> <p align="center">Component Type – Protection System Station dc Supply Using Valve-Regulated Lead-Acid (VRLA) Batteries</p> <p align="center">Excluding distributed UFLS and distributed UVLS (see Table 3)</p> <p align="center">Protection System Station dc supply used only for non-BES interrupting devices for RAS, non-distributed UFLS systems, or non-distributed UVLS systems is excluded (see Table 1-4(e)).</p>		
Component Attributes	Maximum Maintenance Interval	Maintenance Activities
	6 Calendar Months -or- 3 Calendar Years	Verify that the station battery can perform as manufactured by evaluating cell/unit measurements indicative of battery performance (e.g. internal ohmic values or float current) against the station battery baseline. -or- Verify that the station battery can perform as manufactured by conducting a performance or modified performance capacity test of the entire battery bank.

Table 1-4(c) Component Type – Protection System Station dc Supply Using Nickel-Cadmium (NiCad) Batteries Excluding distributed UFLS and distributed UVLS (see Table 3)		
Protection System Station dc supply used only for non-BES interrupting devices for RAS, non-distributed UFLS system, or non-distributed UVLS systems is excluded (see Table 1-4(e)).		
Component Attributes	Maximum Maintenance Interval	Maintenance Activities
Protection System Station dc supply Nickel-Cadmium (NiCad) batteries not having monitoring attributes of Table 1-4(f).	4 Calendar Months	Verify: <ul style="list-style-type: none"> • Station dc supply voltage Inspect: <ul style="list-style-type: none"> • Electrolyte level • For unintentional grounds
	18 Calendar Months	Verify: <ul style="list-style-type: none"> • Float voltage of battery charger • Battery continuity • Battery terminal connection resistance • Battery intercell or unit-to-unit connection resistance Inspect: <ul style="list-style-type: none"> • Cell condition of all individual battery cells. • Physical condition of battery rack

Table 1-4(c)

**Component Type – Protection System Station dc Supply Using Nickel-Cadmium (NiCad) Batteries
Excluding distributed UFLS and distributed UVLS (see Table 3)**

Protection System Station dc supply used only for non-BES interrupting devices for RAS, non-distributed UFLS system, or non-distributed UVLS systems is excluded (see Table 1-4(e)).

Component Attributes	Maximum Maintenance Interval	Maintenance Activities
	6 Calendar Years	Verify that the station battery can perform as manufactured by conducting a performance or modified performance capacity test of the entire battery bank.

Table 1-4(d) Component Type – Protection System Station dc Supply Using Non Battery Based Energy Storage Excluding distributed UFLS and distributed UVLS (see Table 3)		
Protection System Station dc supply used only for non-BES interrupting devices for RAS, non-distributed UFLS system, or non-distributed UVLS systems is excluded (see Table 1-4(e)).		
Component Attributes	Maximum Maintenance Interval	Maintenance Activities
Any Protection System station dc supply not using a battery and not having monitoring attributes of Table 1-4(f).	4 Calendar Months	Verify: <ul style="list-style-type: none"> • Station dc supply voltage Inspect: <ul style="list-style-type: none"> • For unintentional grounds
	18 Calendar Months	Inspect: Condition of non-battery based dc supply
	6 Calendar Years	Verify that the dc supply can perform as manufactured when ac power is not present.

Table 1-4(e) Component Type – Protection System Station dc Supply for non-BES Interrupting Devices for RAS, non-distributed UFLS, and non-distributed UVLS systems		
Component Attributes	Maximum Maintenance Interval	Maintenance Activities
Any Protection System dc supply used for tripping only non-BES interrupting devices as part of a RAS, non-distributed UFLS, or non-distributed UVLS system and not having monitoring attributes of Table 1-4(f).	When control circuits are verified (See Table 1-5)	Verify Station dc supply voltage.

Table 1-4(f) Exclusions for Protection System Station dc Supply Monitoring Devices and Systems		
Component Attributes	Maximum Maintenance Interval	Maintenance Activities
Any station dc supply with high and low voltage monitoring and alarming of the battery charger voltage to detect charger overvoltage and charger failure (See Table 2).	No periodic maintenance specified	No periodic verification of station dc supply voltage is required.
Any battery based station dc supply with electrolyte level monitoring and alarming in every cell (See Table 2).		No periodic inspection of the electrolyte level for each cell is required.
Any station dc supply with unintentional dc ground monitoring and alarming (See Table 2).		No periodic inspection of unintentional dc grounds is required.
Any station dc supply with charger float voltage monitoring and alarming to ensure correct float voltage is being applied on the station dc supply (See Table 2).		No periodic verification of float voltage of battery charger is required.
Any battery based station dc supply with monitoring and alarming of battery string continuity (See Table 2).		No periodic verification of the battery continuity is required.
Any battery based station dc supply with monitoring and alarming of the intercell and/or terminal connection detail resistance of the entire battery (See Table 2).		No periodic verification of the intercell and terminal connection resistance is required.
Any Valve Regulated Lead-Acid (VRLA) or Vented Lead-Acid (VLA) station battery with internal ohmic value or float current monitoring and alarming, and evaluating present values relative to baseline internal ohmic values for every cell/unit (See Table 2).		No periodic evaluation relative to baseline of battery cell/unit measurements indicative of battery performance is required to verify the station battery can perform as manufactured.
Any Valve Regulated Lead-Acid (VRLA) or Vented Lead-Acid (VLA) station battery with monitoring and alarming of each cell/unit internal ohmic value (See Table 2).		No periodic inspection of the condition of all individual units by measuring battery cell/unit internal ohmic values of a station VRLA or Vented Lead-Acid (VLA) battery is required.

Table 1-5 Component Type - Control Circuitry Associated With Protective Functions Excluding distributed UFLS and distributed UVLS (see Table 3), Automatic Reclosing (see Table 4), and Sudden Pressure Relaying (see Table 5) Note: Table requirements apply to all Control Circuitry Components of Protection Systems, and RAS except as noted.		
Component Attributes	Maximum Maintenance Interval	Maintenance Activities
Trip coils or actuators of circuit breakers, interrupting devices, or mitigating devices (regardless of any monitoring of the control circuitry).	6 Calendar Years	Verify that each trip coil is able to operate the circuit breaker, interrupting device, or mitigating device.
Electromechanical lockout devices which are directly in a trip path from the protective relay to the interrupting device trip coil (regardless of any monitoring of the control circuitry).	6 Calendar Years	Verify electrical operation of electromechanical lockout devices.
Unmonitored control circuitry associated with RAS. (See Table 4-2(b) for RAS which include Automatic Reclosing.)	12 Calendar Years	Verify all paths of the control circuits essential for proper operation of the RAS.
Unmonitored control circuitry associated with protective functions inclusive of all auxiliary relays.	12 Calendar Years	Verify all paths of the trip circuits inclusive of all auxiliary relays through the trip coil(s) of the circuit breakers or other interrupting devices.
Control circuitry associated with protective functions and/or RAS whose integrity is monitored and alarmed (See Table 2).	No periodic maintenance specified	None.

Table 2 – Alarming Paths and Monitoring In Tables 1-1 through 1-5, Table 3, Tables 4-1 through 4-2, and Table 5 alarm attributes used to justify extended maximum maintenance intervals and/or reduced maintenance activities are subject to the following maintenance requirements		
Component Attributes	Maximum Maintenance Interval	Maintenance Activities
Any alarm path through which alarms in Tables 1-1 through 1-5, Table 3, Tables 4-1 through 4-2, and Table 5 are conveyed from the alarm origin to the location where corrective action can be initiated, and not having all the attributes of the “Alarm Path with monitoring” category below. Alarms are reported within 24 hours of detection to a location where corrective action can be initiated.	12 Calendar Years	Verify that the alarm path conveys alarm signals to a location where corrective action can be initiated.
Alarm Path with monitoring: The location where corrective action is taken receives an alarm within 24 hours for failure of any portion of the alarming path from the alarm origin to the location where corrective action can be initiated.	No periodic maintenance specified	None.

Table 3 Maintenance Activities and Intervals for distributed UFLS and distributed UVLS Systems		
Component Attributes	Maximum Maintenance Interval	Maintenance Activities
Any unmonitored protective relay not having all the monitoring attributes of a category below.	6 Calendar Years	<p>Verify that settings are as specified.</p> <p>For non-microprocessor relays:</p> <ul style="list-style-type: none"> • Test and, if necessary calibrate. <p>For microprocessor relays:</p> <ul style="list-style-type: none"> • Verify operation of the relay inputs and outputs that are essential to proper functioning of the Protection System. • Verify acceptable measurement of power system input values.
<p>Monitored microprocessor protective relay with the following:</p> <ul style="list-style-type: none"> • Internal self-diagnosis and alarming (See Table 2). • Voltage and/or current waveform sampling three or more times per power cycle, and conversion of samples to numeric values for measurement calculations by microprocessor electronics. <p>Alarming for power supply failure (See Table 2).</p>	12 Calendar Years	<p>Verify:</p> <ul style="list-style-type: none"> • Settings are as specified. • Operation of the relay inputs and outputs that are essential to proper functioning of the Protection System. • Acceptable measurement of power system input values
<p>Monitored microprocessor protective relay with preceding row attributes and the following:</p> <ul style="list-style-type: none"> • Ac measurements are continuously verified by comparison to an independent ac measurement source, with alarming for excessive error (See Table 2). 	12 Calendar Years	<p>Verify only the unmonitored relay inputs and outputs that are essential to proper functioning of the Protection System.</p>

Table 3 Maintenance Activities and Intervals for distributed UFLS and distributed UVLS Systems		
Component Attributes	Maximum Maintenance Interval	Maintenance Activities
<ul style="list-style-type: none"> Some or all binary or status inputs and control outputs are monitored by a process that continuously demonstrates ability to perform as designed, with alarming for failure (See Table 2). Alarming for change of settings (See Table 2).		
Voltage and/or current sensing devices associated with UFLS or UVLS systems.	12 Calendar Years	Verify that current and/or voltage signal values are provided to the protective relays.
Protection System dc supply for tripping non-BES interrupting devices used only for a UFLS or UVLS system.	12 Calendar Years	Verify Protection System dc supply voltage.
Control circuitry between the UFLS or UVLS relays and electromechanical lockout and/or tripping auxiliary devices (excludes non-BES interrupting device trip coils).	12 Calendar Years	Verify the path from the relay to the lockout and/or tripping auxiliary relay (including essential supervisory logic).
Electromechanical lockout and/or tripping auxiliary devices associated only with UFLS or UVLS systems (excludes non-BES interrupting device trip coils).	12 Calendar Years	Verify electrical operation of electromechanical lockout and/or tripping auxiliary devices.
Control circuitry between the electromechanical lockout and/or tripping auxiliary devices and the non-BES interrupting devices in UFLS or UVLS systems, or between UFLS or UVLS relays (with no interposing electromechanical lockout or auxiliary device) and the non-BES interrupting devices (excludes non-BES interrupting device trip coils).	No periodic maintenance specified	None.
Trip coils of non-BES interrupting devices in UFLS or UVLS systems.	No periodic maintenance specified	None.

Table 4-1 Maintenance Activities and Intervals for Automatic Reclosing Components Component Type – Reclosing Relay		
Component Attributes	Maximum Maintenance Interval	Maintenance Activities
Any unmonitored reclosing relay not having all the monitoring attributes of a category below.	6 Calendar Years	Verify that settings are as specified. For non-microprocessor relays: <ul style="list-style-type: none"> • Test and, if necessary calibrate For microprocessor relays: <ul style="list-style-type: none"> • Verify operation of the relay inputs and outputs that are essential to proper functioning of the Automatic Reclosing.
Monitored microprocessor reclosing relay with the following: <ul style="list-style-type: none"> • Internal self-diagnosis and alarming (See Table 2). • Alarming for power supply failure (See Table 2). 	12 Calendar Years	Verify: <ul style="list-style-type: none"> • Settings are as specified. • Operation of the relay inputs and outputs that are essential to proper functioning of the Automatic Reclosing.

Table 4-2(a) Maintenance Activities and Intervals for Automatic Reclosing Components Component Type – Control Circuitry Associated with Reclosing Relays that are NOT an Integral Part of an RAS		
Component Attributes	Maximum Maintenance Interval	Maintenance Activities
Unmonitored Control circuitry associated with Automatic Reclosing that is not an integral part of an RAS.	12 Calendar Years	Verify that Automatic Reclosing, upon initiation, does not issue a premature closing command to the close circuitry.
Control circuitry associated with Automatic Reclosing that is not part of an RAS and is monitored and alarmed for conditions that would result in a premature closing command. (See Table 2)	No periodic maintenance specified	None.

Table 4-2(b) Maintenance Activities and Intervals for Automatic Reclosing Components Component Type – Control Circuitry Associated with Reclosing Relays that ARE an Integral Part of an RAS		
Component Attributes	Maximum Maintenance Interval	Maintenance Activities
Close coils or actuators of circuit breakers or similar devices that are used in conjunction with Automatic Reclosing as part of an RAS (regardless of any monitoring of the control circuitry).	6 Calendar Years	Verify that each close coil or actuator is able to operate the circuit breaker or mitigating device.
Unmonitored close control circuitry associated with Automatic Reclosing used as an integral part of an RAS.	12 Calendar Years	Verify all paths of the control circuits associated with Automatic Reclosing that are essential for proper operation of the RAS.
Control circuitry associated with Automatic Reclosing that is an integral part of an RAS whose integrity is monitored and alarmed. (See Table 2)	No periodic maintenance specified	None.

<p style="text-align: center;">Table 5 Maintenance Activities and Intervals for Sudden Pressure Relaying</p> <p style="text-align: center;">Note: In cases where Components of Sudden Pressure Relaying are common to Components listed in Table 1-5, the Components only need to be tested once during a distinct maintenance interval.</p>		
Component Attributes	Maximum Maintenance Interval	Maintenance Activities
Any fault pressure relay.	6 Calendar Years	Verify the pressure or flow sensing mechanism is operable.
Electromechanical lockout devices which are directly in a trip path from the fault pressure relay to the interrupting device trip coil (regardless of any monitoring of the control circuitry).	6 Calendar Years	Verify electrical operation of electromechanical lockout devices.
Unmonitored control circuitry associated with Sudden Pressure Relaying.	12 Calendar Years	Verify all paths of the trip circuits inclusive of all auxiliary relays through the trip coil(s) of the circuit breakers or other interrupting devices.
Control circuitry associated with Sudden Pressure Relaying whose integrity is monitored and alarmed (See Table 2).	No periodic maintenance specified	None.

PRC-005 — Attachment A

Criteria for a Performance-Based Protection System Maintenance Program

Purpose: To establish a technical basis for initial and continued use of a performance-based Protection System Maintenance Program (PSMP).

To establish the technical justification for the initial use of a performance-based PSMP:

1. Develop a list with a description of Components included in each designated Segment, with a minimum Segment population of 60 Components.
2. Maintain the Components in each Segment according to the time-based maximum allowable intervals established in Tables 1-1 through 1-5, Table 3, Tables 4-1 through 4-2, and Table 5 until results of maintenance activities for the Segment are available for a minimum of 30 individual Components of the Segment.
3. Document the maintenance program activities and results for each Segment, including maintenance dates and Countable Events for each included Component.
4. Analyze the maintenance program activities and results for each Segment to determine the overall performance of the Segment and develop maintenance intervals.
5. Determine the maximum allowable maintenance interval for each Segment such that the Segment experiences Countable Events on no more than 4% of the Components within the Segment, for the greater of either the last 30 Components maintained or all Components maintained in the previous year.

To maintain the technical justification for the ongoing use of a performance-based PSMP:

1. At least annually, update the list of Components and Segments and/or description if any changes occur within the Segment.
2. Perform maintenance on the greater of 5% of the Components (addressed in the performance based PSMP) in each Segment or 3 individual Components within the Segment in each year.
3. For the prior year, analyze the maintenance program activities and results for each Segment to determine the overall performance of the Segment.
4. Using the prior year's data, determine the maximum allowable maintenance interval for each Segment such that the Segment experiences Countable Events on no more than 4% of the Components within the Segment, for the greater of either the last 30 Components maintained or all Components maintained in the previous year.

If the Components in a Segment maintained through a performance-based PSMP experience 4% or more Countable Events, develop, document, and implement an action plan to reduce the Countable Events to less than 4% of the Segment population within 3 years.

Rationale:

During development of this standard, text boxes were embedded within the standard to explain the rationale for various parts of the standard. Upon BOT approval, the text from the rationale text boxes was moved to this section.

Rationale for Applicability Section:

This section does not reflect the applicability changes that will be proposed by the Project 2014-01 Standards Applicability for Dispersed Generation Resources standards drafting team. The changes in this posted version and those being made by the Project 2014-01 standards drafting team do not overlap.

Additionally, to align with ongoing NERC standards development in Project 2010-05.2: Special Protection Systems, the term “Special Protection Systems” in PRC-005-4 was replaced by the term “Remedial Action Schemes.” These terms are synonymous in the NERC Glossary of Terms.

Rationale for the deletion of part of the definition of Component:

The SDT determined that it was explanatory in nature and adequately addressed in the Supplementary Reference and FAQ Document.

Rationale for R3 Part 3.1:

In the last posting, the SDT included language in the standard that was originally in the implementation plan that required completion of maintenance activities within three years for newly-identified Automatic Reclosing Components following a notification under Requirement R6, which has been removed. After further discussion, the SDT determined that a separate shorter timeframe for maintenance of newly-identified Automatic Reclosing Components created unnecessary complication within the standard. The SDT agreed that entities should be responsible for maintaining the Automatic Reclosing Components subject to the standard, whether existing, newly added or newly within scope based on a change in the largest generating unit in the BA or, if a member of a Reserve Sharing Group, the largest generating unit within the Reserve Sharing Group according to the timeframes in the maintenance tables. Therefore, 3.1 and its subparts have been removed and have not been reinserted into the implementation plan.

Rationale for R4 Part 4.1:

In the last posting, the SDT included language in the standard that was originally in the implementation plan that required completion of maintenance activities within three years for newly-identified Automatic Reclosing Components following a notification under Requirement R6, which has been removed. After further discussion, the SDT determined that a separate shorter timeframe for maintenance of newly-identified Automatic Reclosing Components created unnecessary complication within the standard. The SDT agreed that entities should be responsible for maintaining the Automatic Reclosing Components subject to the standard, whether existing, newly added or newly within scope based on a change in the largest generating unit in the BA or, if a member of a Reserve Sharing Group, the largest generating

unit within the Reserve Sharing Group according to the timeframes in the maintenance tables. Therefore, 4.1 and its subparts have been removed and have not been reinserted into the implementation plan.

Rationale for section 4.2.5:

These applicability revisions are intended to clarify and provide for consistent application of the Requirements to BES generator Facilities included in the BES through Inclusion I4 – Dispersed Power Producing Resources. The SDT modified the language for clarity based on comments received and is not changing the intent of the standard modification from the last posted version of this standard.

Redline Version

PRC-005-5 to PRC-005-4

A. Introduction

1. **Title:** Protection System, Automatic Reclosing, and Sudden Pressure Relaying Maintenance
2. **Number:** PRC-005-45
3. **Purpose:** To document and implement programs for the maintenance of all Protection Systems, Automatic Reclosing, and Sudden Pressure Relaying affecting the reliability of the Bulk Electric System (BES) so that they are kept in working order.
4. **Applicability:**
 - 4.1. **Functional Entities:**
 - 4.1.1 Transmission Owner
 - 4.1.2 Generator Owner
 - 4.1.3 Distribution Provider
 - 4.2. **Facilities:**
 - 4.2.1 Protection Systems and Sudden Pressure Relaying that are installed for the purpose of detecting Faults on BES Elements (lines, buses, transformers, etc.)
 - 4.2.2 Protection Systems used for underfrequency load-shedding systems installed per ERO underfrequency load-shedding requirements.
 - 4.2.3 Protection Systems used for undervoltage load-shedding systems installed to prevent system voltage collapse or voltage instability for BES reliability.
 - 4.2.4 Protection Systems installed as a Remedial Action Scheme (RAS) for BES reliability.
 - 4.2.5 Protection Systems and Sudden Pressure Relaying for generator Facilities that are part of the BES, including-except for generators identified through Inclusion I4 of the BES definition, including:
 - 4.2.5.1 Protection Systems that act to trip the generator either directly or via lockout or auxiliary tripping relays.
 - 4.2.5.2 Protection Systems and Sudden Pressure Relaying for generator step-up transformers for generators that are part of the BES.
 - ~~4.2.5.3 Protection Systems and Sudden Pressure Relaying for transformers connecting aggregated generation, where the aggregated generation is part of the BES (e.g., transformers connecting facilities such as wind farms to the BES).~~

~~4.2.5.44.2.5.3~~ -Protection Systems and Sudden Pressure Relaying for station service or excitation transformers connected to the generator bus of generators which are part of the BES, that act to trip the generator either directly or via lockout or tripping auxiliary relays.

4.2.6 Protection Systems and Sudden Pressure Relaying for the following BES generator Facilities for dispersed power producing resources identified through Inclusion I4 of the BES definition:

4.2.6.1 Protection Systems and Sudden Pressure Relaying for Facilities used in aggregating dispersed BES generation from the point where those resources aggregate to greater than 75 MVA to a common point of connection at 100kV or above.

~~4.2.64.2.7~~ Automatic Reclosing¹, including:

~~4.2.6.14.2.7.1~~ Automatic Reclosing applied on the terminals of Elements connected to the BES bus located at generating plant substations where the total installed gross generating plant capacity is greater than the gross capacity of the largest BES generating unit within the Balancing Authority Area or, if a member of a Reserve Sharing Group, the largest generating unit within the Reserve Sharing Group.²

~~4.2.6.24.2.7.2~~ Automatic Reclosing applied on the terminals of all BES Elements at substations one bus away from generating plants specified in Section 4.2.~~67.1~~ when the substation is less than 10 circuit-miles from the generating plant substation.

~~4.2.6.34.2.7.3~~ Automatic Reclosing applied as an integral part of an RAS specified in Section 4.2.4.

5. **Effective Date:** See [the Implementation Plan for this standard.](#)

6. **Definitions Used in this Standard:**

Automatic Reclosing – Includes the following Components:

- Reclosing relay

¹ Automatic Reclosing addressed in Section 4.2.~~67.1~~ and 4.2.~~67.2~~ may be excluded if the equipment owner can demonstrate that a close-in three-phase fault present for twice the normal clearing time (capturing a minimum trip-close-trip time delay) does not result in a total loss of gross generation in the Interconnection exceeding the gross capacity of the largest relevant BES generating unit where the Automatic Reclosing is applied.

² The largest BES generating unit within the Balancing Authority Area or the largest generating unit within the Reserve Sharing Group, as applicable, is subject to change. As a result of such a change, the Automatic Reclosing Components subject to the standard could change effective on the date of such change.

- Control circuitry associated with the reclosing relay.

Sudden Pressure Relaying – A system that trips an interrupting device(s) to isolate the equipment it is monitoring and includes the following Components:

- Fault pressure relay – a mechanical relay or device that detects rapid changes in gas pressure, oil pressure, or oil flow that are indicative of Faults within liquid-filled, wire-wound equipment
- Control circuitry associated with a fault pressure relay

Unresolved Maintenance Issue – A deficiency identified during a maintenance activity that causes the Component to not meet the intended performance, cannot be corrected during the maintenance interval, and requires follow-up corrective action.

Segment – Components of a consistent design standard, or a particular model or type from a single manufacturer that typically share other common elements. Consistent performance is expected across the entire population of a Segment. A Segment must contain at least sixty (60) individual Components.

Component Type –

- Any one of the five specific elements of a Protection System.
- Any one of the two specific elements of Automatic Reclosing.
- Any one of the two specific elements of Sudden Pressure Relaying.

Component – Any individual discrete piece of equipment included in a Protection System, Automatic Reclosing, or Sudden Pressure Relaying.

Countable Event – A failure of a Component requiring repair or replacement, any condition discovered during the maintenance activities in Tables 1-1 through 1-5, Table 3, Tables 4-1 through 4-2, and Table 5, which requires corrective action or a Protection System Misoperation attributed to hardware failure or calibration failure.

Misoperations due to product design errors, software errors, relay settings different from specified settings, Protection System Component, Automatic Reclosing, or Sudden Pressure Relaying configuration or application errors are not included in Countable Events.

B. Requirements and Measures

- R1.** Each Transmission Owner, Generator Owner, and Distribution Provider shall establish a Protection System Maintenance Program (PSMP) for its Protection Systems, Automatic Reclosing, and Sudden Pressure Relaying identified in Section 4.2, Facilities. *[Violation Risk Factor: Medium] [Time Horizon: Operations Planning]*

The PSMP shall:

- 1.1.** Identify which maintenance method (time-based, performance-based per PRC-005 Attachment A, or a combination) is used to address each Protection System,

Automatic Reclosing, and Sudden Pressure Relaying Component Type. All batteries associated with the station dc supply Component Type of a Protection System shall be included in a time-based program as described in Table 1-4 and Table 3.

- 1.2.** Include the applicable monitored Component attributes applied to each Protection System, Automatic Reclosing, and Sudden Pressure Relaying Component Type consistent with the maintenance intervals specified in Tables 1-1 through 1-5, Table 2, Table 3, Table 4-1 through 4-2, and Table 5 where monitoring is used to extend the maintenance intervals beyond those specified for unmonitored Protection System, Automatic Reclosing, and Sudden Pressure Relaying Components.
- M1.** Each Transmission Owner, Generator Owner and Distribution Provider shall have a documented Protection System Maintenance Program in accordance with Requirement R1.

For each Protection System, Automatic Reclosing, and Sudden Pressure Relaying Component Type, the documentation shall include the type of maintenance method applied (time-based, performance-based, or a combination of these maintenance methods), and shall include all batteries associated with the station dc supply Component Types in a time-based program as described in Table 1-4 and Table 3. (Part 1.1)

For Component Types that use monitoring to extend the maintenance intervals, the responsible entity(s) shall have evidence for each Protection System, Automatic Reclosing, and Sudden Pressure Relaying Component Type (such as manufacturer's specifications or engineering drawings) of the appropriate monitored Component attributes as specified in Tables 1-1 through 1-5, Table 2, Table 3, Table 4-1 through 4-2, and Table 5. (Part 1.2)
- R2.** Each Transmission Owner, Generator Owner, and Distribution Provider that uses performance-based maintenance intervals in its PSMP shall follow the procedure established in PRC-005 Attachment A to establish and maintain its performance-based intervals. *[Violation Risk Factor: Medium] [Time Horizon: Operations Planning]*
- M2.** Each Transmission Owner, Generator Owner, and Distribution Provider that uses performance-based maintenance intervals shall have evidence that its current performance-based maintenance program(s) is in accordance with Requirement R2, which may include, but is not limited to, Component lists, dated maintenance records, and dated analysis records and results.
- R3.** Each Transmission Owner, Generator Owner, and Distribution Provider that utilizes time-based maintenance program(s) shall maintain its Protection System, Automatic Reclosing, and Sudden Pressure Relaying Components that are included within the time-based maintenance program in accordance with the minimum maintenance activities and maximum maintenance intervals prescribed within Tables 1-1 through

1-5, Table 2, Table 3, Table 4-1 through 4-2, and Table 5. *[Violation Risk Factor: High]*
[Time Horizon: Operations Planning]

- M3.** Each Transmission Owner, Generator Owner, and Distribution Provider that utilizes time-based maintenance program(s) shall have evidence that it has maintained its Protection System, Automatic Reclosing, and Sudden Pressure Relaying Components included within its time-based program in accordance with Requirement R3. The evidence may include, but is not limited to, dated maintenance records, dated maintenance summaries, dated check-off lists, dated inspection records, or dated work orders.
- R4.** Each Transmission Owner, Generator Owner, and Distribution Provider that utilizes performance-based maintenance program(s) in accordance with Requirement R2 shall implement and follow its PSMP for its Protection System, Automatic Reclosing, and Sudden Pressure Relaying Components that are included within the performance-based program(s). *[Violation Risk Factor: High]* *[Time Horizon: Operations Planning]*
- M4.** Each Transmission Owner, Generator Owner, and Distribution Provider that utilizes performance-based maintenance intervals in accordance with Requirement R2 shall have evidence that it has implemented the Protection System Maintenance Program for the Protection System, Automatic Reclosing, and Sudden Pressure Relaying Components included in its performance-based program in accordance with Requirement R4. The evidence may include, but is not limited to, dated maintenance records, dated maintenance summaries, dated check-off lists, dated inspection records, or dated work orders.
- R5.** Each Transmission Owner, Generator Owner, and Distribution Provider shall demonstrate efforts to correct identified Unresolved Maintenance Issues. *[Violation Risk Factor: Medium]* *[Time Horizon: Operations Planning]*
- M5.** Each Transmission Owner, Generator Owner, and Distribution Provider shall have evidence that it has undertaken efforts to correct identified Unresolved Maintenance Issues in accordance with Requirement R5. The evidence may include, but is not limited to, work orders, replacement Component orders, invoices, project schedules with completed milestones, return material authorizations (RMAs) or purchase orders.

C. Compliance

1. Compliance Monitoring Process

1.1. Compliance Enforcement Authority

As defined in the NERC Rules of Procedure, “Compliance Enforcement Authority” means NERC or the Regional Entity in their respective roles of monitoring and enforcing compliance with the NERC Reliability Standards.

1.2. Evidence Retention

The following evidence retention periods identify the period of time an entity is required to retain specific evidence to demonstrate compliance. For instances where the evidence retention period specified below is shorter than the time since the last audit, the Compliance Enforcement Authority may ask an entity to provide other evidence to show that it was compliant for the full time period since the last audit.

The Transmission Owner, Generator Owner, and Distribution Provider shall each keep data or evidence to show compliance as identified below unless directed by its Compliance Enforcement Authority to retain specific evidence for a longer period of time as part of an investigation.

For Requirement R1, the Transmission Owner, Generator Owner, and Distribution Provider shall each keep its current dated Protection System Maintenance Program, as well as any superseded versions since the preceding compliance audit, including the documentation that specifies the type of maintenance program applied for each Protection System, Automatic Reclosing, or Sudden Pressure Relaying Component Type.

For Requirement R2, Requirement R3, and Requirement R4, in cases where the interval of the maintenance activity is longer than the audit cycle, the Transmission Owner, Generator Owner, and Distribution Provider shall each keep documentation of the most recent performance of that maintenance activity for the Protection System, Automatic Reclosing, or Sudden Pressure Relaying Component. In cases where the interval of the maintenance activity is shorter than the audit cycle, documentation of all performances (in accordance with the tables) of that maintenance activity for the Protection System, Automatic Reclosing, or Sudden Pressure Relaying Component since the previous scheduled audit date shall be retained.

For Requirement R5 the Transmission Owner, Generator Owner, and Distribution Provider shall each keep documentation of Unresolved Maintenance Issues identified by the entity since the last audit, including all that were resolved since the last audit.

The Compliance Enforcement Authority shall keep the last audit records and all requested and submitted subsequent audit records.

1.3. Compliance Monitoring and Assessment Processes:

- Compliance Audits
- Self-Certifications
- Spot Checking
- Compliance Violation Investigations
- Self-Reporting

Complaints

1.4. Additional Compliance Information

None

Table of Compliance Elements

Requirement Number	Lower VSL	Moderate VSL	High VSL	Severe VSL
R1 ₂	The entity's PSMP failed to specify whether one Component Type is being addressed by time-based or performance-based maintenance, or a combination of both (Part 1.1).	The entity's PSMP failed to specify whether two Component Types are being addressed by time-based or performance-based maintenance, or a combination of both (Part 1.1).	The entity's PSMP failed to specify whether three Component Types are being addressed by time-based or performance-based maintenance, or a combination of both. (Part 1.1). OR The entity's PSMP failed to include the applicable monitoring attributes applied to each Component Type consistent with the maintenance intervals specified in Tables 1-1 through 1-5, Table 2, Table 3, Tables 4-1 through 4-2, and Table 5 where monitoring is used to extend the maintenance intervals beyond those specified for unmonitored Components (Part 1.2).	The entity failed to establish a PSMP. OR The entity's PSMP failed to specify whether four or more Component Types are being addressed by time-based or performance-based maintenance, or a combination of both (Part 1.1). OR The entity's PSMP failed to include applicable station batteries in a time-based program (Part 1.1).
R2 ₂	The entity uses performance-based maintenance intervals in its PSMP but failed to reduce Countable Events to no more than 4% within three years.	NA	The entity uses performance-based maintenance intervals in its PSMP but failed to reduce Countable Events to no more than 4% within four years.	The entity uses performance-based maintenance intervals in its PSMP but: 1) Failed to establish the technical justification described within Requirement R2 for the initial use of the performance-based PSMP OR 2) Failed to reduce Countable Events to no more than 4% within five years OR

Requirement Number	Lower VSL	Moderate VSL	High VSL	Severe VSL
				3) Maintained a Segment with less than 60 Components OR 4) Failed to: <ul style="list-style-type: none"> • Annually update the list of Components, OR • Annually perform maintenance on the greater of 5% of the Segment population or 3 Components, OR • Annually analyze the program activities and results for each Segment.
R3_	For Components included within a time-based maintenance program, the entity failed to maintain 5% or less of the total Components included within a specific Component Type in accordance with the minimum maintenance activities and maximum maintenance intervals prescribed within Tables 1-1 through 1-5, Table 2, Table 3, Tables 4-1 through 4-2, and Table 5.	For Components included within a time-based maintenance program, the entity failed to maintain more than 5% but 10% or less of the total Components included within a specific Component Type in accordance with the minimum maintenance activities and maximum maintenance intervals prescribed within Tables 1-1 through 1-5, Table 2, Table 3, Tables 4-1 through 4-2, and Table 5.	For Components included within a time-based maintenance program, the entity failed to maintain more than 10% but 15% or less of the total Components included within a specific Component Type in accordance with the minimum maintenance activities and maximum maintenance intervals prescribed within Tables 1-1 through 1-5, Table 2, Table 3, Tables 4-1 through 4-2, and Table 5.	For Components included within a time-based maintenance program, the entity failed to maintain more than 15% of the total Components included within a specific Component Type in accordance with the minimum maintenance activities and maximum maintenance intervals prescribed within Tables 1-1 through 1-5, Table 2, Table 3, Tables 4-1 through 4-2, and Table 5.

Requirement Number	Lower VSL	Moderate VSL	High VSL	Severe VSL
R4.	For Components included within a performance-based maintenance program, the entity failed to maintain 5% or less of the annual scheduled maintenance for a specific Component Type in accordance with their performance-based PSMP.	For Components included within a performance-based maintenance program, the entity failed to maintain more than 5% but 10% or less of the annual scheduled maintenance for a specific Component Type in accordance with their performance-based PSMP.	For Components included within a performance-based maintenance program, the entity failed to maintain more than 10% but 15% or less of the annual scheduled maintenance for a specific Component Type in accordance with their performance-based PSMP.	For Components included within a performance-based maintenance program, the entity failed to maintain more than 15% of the annual scheduled maintenance for a specific Component Type in accordance with their performance-based PSMP.
R5.	The entity failed to undertake efforts to correct 5 or fewer identified Unresolved Maintenance Issues.	The entity failed to undertake efforts to correct greater than 5 but less than or equal to 10 identified Unresolved Maintenance Issues.	The entity failed to undertake efforts to correct greater than 10 but less than or equal to 15 identified Unresolved Maintenance Issues.	The entity failed to undertake efforts to correct greater than 15 identified Unresolved Maintenance Issues.

D. Regional Variances

None.

E. Interpretations

None.

Supplemental Reference Documents

The following documents present a detailed discussion about determination of maintenance intervals and other useful information regarding establishment of a maintenance program.

1. *Supplementary Reference and FAQ - PRC-005-4 Protection System Maintenance*, Protection System Maintenance and Testing Standard Drafting Team (April 2014)
2. *Considerations for Maintenance and Testing of Auto-reclosing Schemes*, NERC System Analysis and Modeling Subcommittee, and NERC System Protection and Control Subcommittee (November 2012)
3. *Sudden Pressure Relays and Other Devices that Respond to Non-Electrical Quantities – SPCS Input for Standard Development in Response to FERC Order No. 758*, NERC System Protection and Control Subcommittee (December 2013)
4. *Sudden Pressure Relays and Other Devices that Respond to Non-Electrical Quantities – Supplemental Information to Support Project 2007-17.3: Protection System Maintenance and Testing* (October 31, 2014)

Version History

Version	Date	Action	Change Tracking
0	February 8, 2005	Adopted by NERC Board of Trustees	New
1	February 7, 2006	Adopted by NERC Board of Trustees	<p>1. _____ Changed incorrect use of certain hyphens (-) to “en dash” (–) and “em dash (—).”</p> <p>2. _____ Added “periods” to items where appropriate.</p> <p>_____ Changed “Timeframe” to “Time Frame” in item D, 1.2.</p>
<u>1</u>	<u>March 16, 2007</u>	<u>PRC-005-1 Approved by FERC. Docket No. RM06-16-000</u>	

Version	Date	Action	Change Tracking
1a	February 17, 2011	Adopted by NERC Board of Trustees	Added Appendix 1 - Interpretation regarding applicability of standard to protection of radially connected transformers developed in Project 2009-17
<u>1a</u>	<u>September 26, 2011</u>	<u>Approved by FERC. Docket No. RD11-5-000</u>	
1b	November 5, 2009	Adopted by NERC Board of Trustees	Interpretation of R1, R1.1, and R1.2 developed by Project 2009-10
1b	February 3, 2012	FERC Order approving revised definition of "Protection System"	Per footnote 8 of FERC's order, the definition of "Protection System" supersedes interpretation "b" of PRC-005-1b upon the effective date of the modified definition (i.e., April 1, 2013) <i>See N. Amer. Elec. Reliability Corp., 138 FERC ¶ 61,095 (February 3, 2012).</i>
<u>1b</u>	<u>February 3, 2012</u>	<u>PRC-005-1b Approved by FERC. Docket No. RM10-5-000</u>	
1.1b	May 9, 2012	Adopted by NERC Board of Trustees	Errata change developed by Project 2010-07, clarified inclusion of generator interconnection Facility in Generator Owner's responsibility
<u>1.1b</u>	<u>September 19, 2013</u>	<u>PRC-005-1.1b Approved by FERC. Docket No. RM12-16-000</u>	

Version	Date	Action	Change Tracking
2	November 7, 2012	Adopted by NERC Board of Trustees	Project 2007-17 - Complete revision, absorbing maintenance requirements from PRC-005-1.1b, PRC-008-0, PRC-011-0, PRC-017-0
2	October 17, 2013	Approved by NERC Standards Committee	Errata Change: The Standards Committee approved an errata change to the implementation plan for PRC-005-2 to add the phrase “or as otherwise made effective pursuant to the laws applicable to such ERO governmental authorities;” to the second sentence under the “Retirement of Existing Standards” section. (no change to standard version number)
<u>2</u>	<u>December 19, 2013</u>	<u>PRC-005-2 Approved by FERC. Docket No. RM13-7-000</u>	
2	March 7, 2014	Adopted by NERC Board of Trustees	Modified R1 VSL in response to FERC directive (no change to standard version number)
2(i)	November 13, 2014	Adopted by NERC Board of Trustees	Applicability section revised by Project 2014-01 to clarify application of Requirements to BES dispersed power producing resources

Version	Date	Action	Change Tracking
<u>2(i)</u>	<u>May 29, 2015</u>	<u>PRC-005-2(i) Approved by FERC. Docket No. RD15-3-000</u>	
2(ii)	November 13, 2014	Adopted by NERC Board of Trustees	Replaced references to Special Protection System and SPS with Remedial Action Scheme and RAS
3	November 7, 2013	Adopted by the NERC Board of Trustees	Revised to address the FERC directive in Order No. 758 to include Automatic Reclosing in maintenance programs
3	February 12, 2014	Approved by NERC Standards Committee	Errata Change: The Standards Committee approved errata changes to correct capitalization of certain defined terms within the definitions of “Unresolved Maintenance Issue” and “Protection System Maintenance Program”. The changes will be reflected in the definitions section of PRC-005-3 for “Unresolved Maintenance Issue” and in the NERC Glossary of Terms for “Protection System Maintenance Program”. (no change to standard version number)

Version	Date	Action	Change Tracking
3	March 7, 2014	Adopted by NERC Board of Trustees	Modified R1 VSL in response to FERC directive (no change to standard version number)
<u>3</u>	<u>January 22, 2015</u>	<u>PRC-005-3 Approved by FERC. Docket No. RM14-8-000</u>	
3(i)	November 13, 2014	Adopted by NERC Board of Trustees	Applicability section revised by Project 2014-01 to clarify application of Requirements to BES dispersed power producing resources
<u>3(i)</u>	<u>May 29, 2015</u>	<u>PRC-005-3(i) Approved by FERC. Docket No. RD15-3-000</u>	
3(ii)	November 13, 2014	Adopted by NERC Board of Trustees	Replaced references to Special Protection System and SPS with Remedial Action Scheme and RAS
4	November 13, 2014	Adopted by NERC Board of Trustees	Added Sudden Pressure Relaying in response to FERC Order No. 758
4	September 17, 2015	FERC approved PRC-005-4- Order No. 813. <u>Approved by FERC.</u> Docket No. RM15-9-000	
<u>5</u>	<u>May 7, 2015</u>	<u>Adopted by NERC Board of Trustees</u>	<u>Applicability section revised by Project 2014-01 to clarify application of Requirements to BES dispersed power producing resources</u>

Table 1-1 Component Type - Protective Relay Excluding distributed UFLS and distributed UVLS (see Table 3)		
Component Attributes	Maximum Maintenance Interval ³	Maintenance Activities
Any unmonitored protective relay not having all the monitoring attributes of a category below.	6 Calendar Years	For all unmonitored relays: <ul style="list-style-type: none"> • Verify that settings are as specified For non-microprocessor relays: <ul style="list-style-type: none"> • Test and, if necessary calibrate For microprocessor relays: <ul style="list-style-type: none"> • Verify operation of the relay inputs and outputs that are essential to proper functioning of the Protection System. • Verify acceptable measurement of power system input values.
Monitored microprocessor protective relay with the following: <ul style="list-style-type: none"> • Internal self-diagnosis and alarming (see Table 2). • Voltage and/or current waveform sampling three or more times per power cycle, and conversion of samples to numeric values for measurement calculations by microprocessor electronics. • Alarming for power supply failure (see Table 2). 	12 Calendar Years	Verify: <ul style="list-style-type: none"> • Settings are as specified. • Operation of the relay inputs and outputs that are essential to proper functioning of the Protection System. • Acceptable measurement of power system input values.

³ For the tables in this standard, a calendar year starts on the first day of a new year (January 1) after a maintenance activity has been completed. For the tables in this standard, a calendar month starts on the first day of the first month after a maintenance activity has been completed.

Table 1-1 Component Type - Protective Relay Excluding distributed UFLS and distributed UVLS (see Table 3)		
Component Attributes	Maximum Maintenance Interval ³	Maintenance Activities
Monitored microprocessor protective relay with preceding row attributes and the following: <ul style="list-style-type: none"> • Ac measurements are continuously verified by comparison to an independent ac measurement source, with alarming for excessive error (See Table 2). • Some or all binary or status inputs and control outputs are monitored by a process that continuously demonstrates ability to perform as designed, with alarming for failure (See Table 2). • Alarming for change of settings (See Table 2). 	12 Calendar Years	Verify only the unmonitored relay inputs and outputs that are essential to proper functioning of the Protection System.

Table 1-2 Component Type - Communications Systems Excluding distributed UFLS and distributed UVLS (see Table 3)		
Component Attributes	Maximum Maintenance Interval	Maintenance Activities
Any unmonitored communications system necessary for correct operation of protective functions, and not having all the monitoring attributes of a category below.	4 Calendar Months	Verify that the communications system is functional.
	6 Calendar Years	Verify that the communications system meets performance criteria pertinent to the communications technology applied (e.g. signal level, reflected power, or data error rate). Verify operation of communications system inputs and outputs that are essential to proper functioning of the Protection System.
Any communications system with continuous monitoring or periodic automated testing for the presence of the channel function, and alarming for loss of function (See Table 2).	12 Calendar Years	Verify that the communications system meets performance criteria pertinent to the communications technology applied (e.g. signal level, reflected power, or data error rate). Verify operation of communications system inputs and outputs that are essential to proper functioning of the Protection System.
Any communications system with all of the following: <ul style="list-style-type: none"> • Continuous monitoring or periodic automated testing for the performance of the channel using criteria pertinent to the communications technology applied (e.g. signal level, reflected power, or data error rate, and alarming for excessive performance degradation). (See Table 2) • Some or all binary or status inputs and control outputs are monitored by a process that continuously demonstrates ability to perform as designed, with alarming for failure (See Table 2). 	12 Calendar Years	Verify only the unmonitored communications system inputs and outputs that are essential to proper functioning of the Protection System

Table 1-3 Component Type - Voltage and Current Sensing Devices Providing Inputs to Protective Relays Excluding distributed UFLS and distributed UVLS (see Table 3)		
Component Attributes	Maximum Maintenance Interval	Maintenance Activities
Any voltage and current sensing devices not having monitoring attributes of the category below.	12 Calendar Years	Verify that current and voltage signal values are provided to the protective relays.
Voltage and Current Sensing devices connected to microprocessor relays with AC measurements are continuously verified by comparison of sensing input value, as measured by the microprocessor relay, to an independent ac measurement source, with alarming for unacceptable error or failure (see Table 2).	No periodic maintenance specified	None.

Table 1-4(a) Component Type – Protection System Station dc Supply Using Vented Lead-Acid (VLA) Batteries Excluding distributed UFLS and distributed UVLS (see Table 3)		
Protection System Station dc supply used only for non-BES interrupting devices for RAS, non-distributed UFLS systems, or non-distributed UVLS systems is excluded (see Table 1-4(e)).		
Component Attributes	Maximum Maintenance Interval	Maintenance Activities
Protection System Station dc supply using Vented Lead-Acid (VLA) batteries not having monitoring attributes of Table 1-4(f).	4 Calendar Months	Verify: <ul style="list-style-type: none"> • Station dc supply voltage Inspect: <ul style="list-style-type: none"> • Electrolyte level • For unintentional grounds
	18 Calendar Months	Verify: <ul style="list-style-type: none"> • Float voltage of battery charger • Battery continuity • Battery terminal connection resistance • Battery intercell or unit-to-unit connection resistance Inspect: <ul style="list-style-type: none"> • Cell condition of all individual battery cells where cells are visible – or measure battery cell/unit internal ohmic values where the cells are not visible • Physical condition of battery rack

<p style="text-align: center;">Table 1-4(a) Component Type – Protection System Station dc Supply Using Vented Lead-Acid (VLA) Batteries Excluding distributed UFLS and distributed UVLS (see Table 3)</p> <p style="text-align: center;">Protection System Station dc supply used only for non-BES interrupting devices for RAS, non-distributed UFLS systems, or non-distributed UVLS systems is excluded (see Table 1-4(e)).</p>		
Component Attributes	Maximum Maintenance Interval	Maintenance Activities
	18 Calendar Months -or- 6 Calendar Years	Verify that the station battery can perform as manufactured by evaluating cell/unit measurements indicative of battery performance (e.g. internal ohmic values or float current) against the station battery baseline. -or- Verify that the station battery can perform as manufactured by conducting a performance or modified performance capacity test of the entire battery bank.

Table 1-4(b) Component Type – Protection System Station dc Supply Using Valve-Regulated Lead-Acid (VRLA) Batteries Excluding distributed UFLS and distributed UVLS (see Table 3)		
Protection System Station dc supply used only for non-BES interrupting devices for RAS, non-distributed UFLS systems, or non-distributed UVLS systems is excluded (see Table 1-4(e)).		
Component Attributes	Maximum Maintenance Interval	Maintenance Activities
Protection System Station dc supply with Valve Regulated Lead-Acid (VRLA) batteries not having monitoring attributes of Table 1-4(f).	4 Calendar Months	Verify: <ul style="list-style-type: none"> • Station dc supply voltage Inspect: <ul style="list-style-type: none"> • For unintentional grounds
	6 Calendar Months	Inspect: <ul style="list-style-type: none"> • Condition of all individual units by measuring battery cell/unit internal ohmic values.
	18 Calendar Months	Verify: <ul style="list-style-type: none"> • Float voltage of battery charger • Battery continuity • Battery terminal connection resistance • Battery intercell or unit-to-unit connection resistance Inspect: <ul style="list-style-type: none"> • Physical condition of battery rack

<p style="text-align: center;">Table 1-4(b)</p> <p style="text-align: center;">Component Type – Protection System Station dc Supply Using Valve-Regulated Lead-Acid (VRLA) Batteries</p> <p style="text-align: center;">Excluding distributed UFLS and distributed UVLS (see Table 3)</p> <p style="text-align: center;">Protection System Station dc supply used only for non-BES interrupting devices for RAS, non-distributed UFLS systems, or non-distributed UVLS systems is excluded (see Table 1-4(e)).</p>		
Component Attributes	Maximum Maintenance Interval	Maintenance Activities
	6 Calendar Months -or- 3 Calendar Years	Verify that the station battery can perform as manufactured by evaluating cell/unit measurements indicative of battery performance (e.g. internal ohmic values or float current) against the station battery baseline. -or- Verify that the station battery can perform as manufactured by conducting a performance or modified performance capacity test of the entire battery bank.

Table 1-4(c) Component Type – Protection System Station dc Supply Using Nickel-Cadmium (NiCad) Batteries Excluding distributed UFLS and distributed UVLS (see Table 3)		
Protection System Station dc supply used only for non-BES interrupting devices for RAS, non-distributed UFLS system, or non-distributed UVLS systems is excluded (see Table 1-4(e)).		
Component Attributes	Maximum Maintenance Interval	Maintenance Activities
Protection System Station dc supply Nickel-Cadmium (NiCad) batteries not having monitoring attributes of Table 1-4(f).	4 Calendar Months	Verify: <ul style="list-style-type: none"> • Station dc supply voltage Inspect: <ul style="list-style-type: none"> • Electrolyte level • For unintentional grounds
	18 Calendar Months	Verify: <ul style="list-style-type: none"> • Float voltage of battery charger • Battery continuity • Battery terminal connection resistance • Battery intercell or unit-to-unit connection resistance Inspect: <ul style="list-style-type: none"> • Cell condition of all individual battery cells. • Physical condition of battery rack

Table 1-4(c)

Component Type – Protection System Station dc Supply Using Nickel-Cadmium (NiCad) Batteries
 Excluding distributed UFLS and distributed UVLS (see Table 3)

Protection System Station dc supply used only for non-BES interrupting devices for RAS, non-distributed UFLS system, or non-distributed UVLS systems is excluded (see Table 1-4(e)).

Component Attributes	Maximum Maintenance Interval	Maintenance Activities
	6 Calendar Years	Verify that the station battery can perform as manufactured by conducting a performance or modified performance capacity test of the entire battery bank.

Table 1-4(d) Component Type – Protection System Station dc Supply Using Non Battery Based Energy Storage Excluding distributed UFLS and distributed UVLS (see Table 3)		
Protection System Station dc supply used only for non-BES interrupting devices for RAS, non-distributed UFLS system, or non-distributed UVLS systems is excluded (see Table 1-4(e)).		
Component Attributes	Maximum Maintenance Interval	Maintenance Activities
Any Protection System station dc supply not using a battery and not having monitoring attributes of Table 1-4(f).	4 Calendar Months	Verify: <ul style="list-style-type: none"> • Station dc supply voltage Inspect: <ul style="list-style-type: none"> • For unintentional grounds
	18 Calendar Months	Inspect: Condition of non-battery based dc supply
	6 Calendar Years	Verify that the dc supply can perform as manufactured when ac power is not present.

Table 1-4(e) Component Type – Protection System Station dc Supply for non-BES Interrupting Devices for RAS, non-distributed UFLS, and non-distributed UVLS systems		
Component Attributes	Maximum Maintenance Interval	Maintenance Activities
Any Protection System dc supply used for tripping only non-BES interrupting devices as part of a RAS, non-distributed UFLS, or non-distributed UVLS system and not having monitoring attributes of Table 1-4(f).	When control circuits are verified (See Table 1-5)	Verify Station dc supply voltage.

Table 1-4(f) Exclusions for Protection System Station dc Supply Monitoring Devices and Systems		
Component Attributes	Maximum Maintenance Interval	Maintenance Activities
Any station dc supply with high and low voltage monitoring and alarming of the battery charger voltage to detect charger overvoltage and charger failure (See Table 2).	No periodic maintenance specified	No periodic verification of station dc supply voltage is required.
Any battery based station dc supply with electrolyte level monitoring and alarming in every cell (See Table 2).		No periodic inspection of the electrolyte level for each cell is required.
Any station dc supply with unintentional dc ground monitoring and alarming (See Table 2).		No periodic inspection of unintentional dc grounds is required.
Any station dc supply with charger float voltage monitoring and alarming to ensure correct float voltage is being applied on the station dc supply (See Table 2).		No periodic verification of float voltage of battery charger is required.
Any battery based station dc supply with monitoring and alarming of battery string continuity (See Table 2).		No periodic verification of the battery continuity is required.
Any battery based station dc supply with monitoring and alarming of the intercell and/or terminal connection detail resistance of the entire battery (See Table 2).		No periodic verification of the intercell and terminal connection resistance is required.
Any Valve Regulated Lead-Acid (VRLA) or Vented Lead-Acid (VLA) station battery with internal ohmic value or float current monitoring and alarming, and evaluating present values relative to baseline internal ohmic values for every cell/unit (See Table 2).		No periodic evaluation relative to baseline of battery cell/unit measurements indicative of battery performance is required to verify the station battery can perform as manufactured.
Any Valve Regulated Lead-Acid (VRLA) or Vented Lead-Acid (VLA) station battery with monitoring and alarming of each cell/unit internal ohmic value (See Table 2).		No periodic inspection of the condition of all individual units by measuring battery cell/unit internal ohmic values of a station VRLA or Vented Lead-Acid (VLA) battery is required.

Table 1-5 Component Type - Control Circuitry Associated With Protective Functions Excluding distributed UFLS and distributed UVLS (see Table 3), Automatic Reclosing (see Table 4), and Sudden Pressure Relaying (see Table 5) Note: Table requirements apply to all Control Circuitry Components of Protection Systems, and RAS except as noted.		
Component Attributes	Maximum Maintenance Interval	Maintenance Activities
Trip coils or actuators of circuit breakers, interrupting devices, or mitigating devices (regardless of any monitoring of the control circuitry).	6 Calendar Years	Verify that each trip coil is able to operate the circuit breaker, interrupting device, or mitigating device.
Electromechanical lockout devices which are directly in a trip path from the protective relay to the interrupting device trip coil (regardless of any monitoring of the control circuitry).	6 Calendar Years	Verify electrical operation of electromechanical lockout devices.
Unmonitored control circuitry associated with RAS. (See Table 4-2(b) for RAS which include Automatic Reclosing.)	12 Calendar Years	Verify all paths of the control circuits essential for proper operation of the RAS.
Unmonitored control circuitry associated with protective functions inclusive of all auxiliary relays.	12 Calendar Years	Verify all paths of the trip circuits inclusive of all auxiliary relays through the trip coil(s) of the circuit breakers or other interrupting devices.
Control circuitry associated with protective functions and/or RAS whose integrity is monitored and alarmed (See Table 2).	No periodic maintenance specified	None.

Table 2 – Alarming Paths and Monitoring In Tables 1-1 through 1-5, Table 3, Tables 4-1 through 4-2, and Table 5 alarm attributes used to justify extended maximum maintenance intervals and/or reduced maintenance activities are subject to the following maintenance requirements		
Component Attributes	Maximum Maintenance Interval	Maintenance Activities
Any alarm path through which alarms in Tables 1-1 through 1-5, Table 3, Tables 4-1 through 4-2, and Table 5 are conveyed from the alarm origin to the location where corrective action can be initiated, and not having all the attributes of the “Alarm Path with monitoring” category below. Alarms are reported within 24 hours of detection to a location where corrective action can be initiated.	12 Calendar Years	Verify that the alarm path conveys alarm signals to a location where corrective action can be initiated.
Alarm Path with monitoring: The location where corrective action is taken receives an alarm within 24 hours for failure of any portion of the alarming path from the alarm origin to the location where corrective action can be initiated.	No periodic maintenance specified	None.

Table 3 Maintenance Activities and Intervals for distributed UFLS and distributed UVLS Systems		
Component Attributes	Maximum Maintenance Interval	Maintenance Activities
Any unmonitored protective relay not having all the monitoring attributes of a category below.	6 Calendar Years	<p>Verify that settings are as specified.</p> <p>For non-microprocessor relays:</p> <ul style="list-style-type: none"> • Test and, if necessary calibrate. <p>For microprocessor relays:</p> <ul style="list-style-type: none"> • Verify operation of the relay inputs and outputs that are essential to proper functioning of the Protection System. • Verify acceptable measurement of power system input values.
<p>Monitored microprocessor protective relay with the following:</p> <ul style="list-style-type: none"> • Internal self-diagnosis and alarming (See Table 2). • Voltage and/or current waveform sampling three or more times per power cycle, and conversion of samples to numeric values for measurement calculations by microprocessor electronics. <p>Alarming for power supply failure (See Table 2).</p>	12 Calendar Years	<p>Verify:</p> <ul style="list-style-type: none"> • Settings are as specified. • Operation of the relay inputs and outputs that are essential to proper functioning of the Protection System. • Acceptable measurement of power system input values
<p>Monitored microprocessor protective relay with preceding row attributes and the following:</p> <ul style="list-style-type: none"> • Ac measurements are continuously verified by comparison to an independent ac measurement source, with alarming for excessive error (See Table 2). 	12 Calendar Years	<p>Verify only the unmonitored relay inputs and outputs that are essential to proper functioning of the Protection System.</p>

Table 3 Maintenance Activities and Intervals for distributed UFLS and distributed UVLS Systems		
Component Attributes	Maximum Maintenance Interval	Maintenance Activities
<ul style="list-style-type: none"> Some or all binary or status inputs and control outputs are monitored by a process that continuously demonstrates ability to perform as designed, with alarming for failure (See Table 2). Alarming for change of settings (See Table 2).		
Voltage and/or current sensing devices associated with UFLS or UVLS systems.	12 Calendar Years	Verify that current and/or voltage signal values are provided to the protective relays.
Protection System dc supply for tripping non-BES interrupting devices used only for a UFLS or UVLS system.	12 Calendar Years	Verify Protection System dc supply voltage.
Control circuitry between the UFLS or UVLS relays and electromechanical lockout and/or tripping auxiliary devices (excludes non-BES interrupting device trip coils).	12 Calendar Years	Verify the path from the relay to the lockout and/or tripping auxiliary relay (including essential supervisory logic).
Electromechanical lockout and/or tripping auxiliary devices associated only with UFLS or UVLS systems (excludes non-BES interrupting device trip coils).	12 Calendar Years	Verify electrical operation of electromechanical lockout and/or tripping auxiliary devices.
Control circuitry between the electromechanical lockout and/or tripping auxiliary devices and the non-BES interrupting devices in UFLS or UVLS systems, or between UFLS or UVLS relays (with no interposing electromechanical lockout or auxiliary device) and the non-BES interrupting devices (excludes non-BES interrupting device trip coils).	No periodic maintenance specified	None.
Trip coils of non-BES interrupting devices in UFLS or UVLS systems.	No periodic maintenance specified	None.

Table 4-1 Maintenance Activities and Intervals for Automatic Reclosing Components Component Type – Reclosing Relay		
Component Attributes	Maximum Maintenance Interval	Maintenance Activities
Any unmonitored reclosing relay not having all the monitoring attributes of a category below.	6 Calendar Years	Verify that settings are as specified. For non-microprocessor relays: <ul style="list-style-type: none"> • Test and, if necessary calibrate For microprocessor relays: <ul style="list-style-type: none"> • Verify operation of the relay inputs and outputs that are essential to proper functioning of the Automatic Reclosing.
Monitored microprocessor reclosing relay with the following: <ul style="list-style-type: none"> • Internal self-diagnosis and alarming (See Table 2). • Alarming for power supply failure (See Table 2). 	12 Calendar Years	Verify: <ul style="list-style-type: none"> • Settings are as specified. • Operation of the relay inputs and outputs that are essential to proper functioning of the Automatic Reclosing.

Table 4-2(a) Maintenance Activities and Intervals for Automatic Reclosing Components Component Type – Control Circuitry Associated with Reclosing Relays that are NOT an Integral Part of an RAS		
Component Attributes	Maximum Maintenance Interval	Maintenance Activities
Unmonitored Control circuitry associated with Automatic Reclosing that is not an integral part of an RAS.	12 Calendar Years	Verify that Automatic Reclosing, upon initiation, does not issue a premature closing command to the close circuitry.
Control circuitry associated with Automatic Reclosing that is not part of an RAS and is monitored and alarmed for conditions that would result in a premature closing command. (See Table 2)	No periodic maintenance specified	None.

Table 4-2(b) Maintenance Activities and Intervals for Automatic Reclosing Components Component Type – Control Circuitry Associated with Reclosing Relays that ARE an Integral Part of an RAS		
Component Attributes	Maximum Maintenance Interval	Maintenance Activities
Close coils or actuators of circuit breakers or similar devices that are used in conjunction with Automatic Reclosing as part of an RAS (regardless of any monitoring of the control circuitry).	6 Calendar Years	Verify that each close coil or actuator is able to operate the circuit breaker or mitigating device.
Unmonitored close control circuitry associated with Automatic Reclosing used as an integral part of an RAS.	12 Calendar Years	Verify all paths of the control circuits associated with Automatic Reclosing that are essential for proper operation of the RAS.
Control circuitry associated with Automatic Reclosing that is an integral part of an RAS whose integrity is monitored and alarmed. (See Table 2)	No periodic maintenance specified	None.

<p style="text-align: center;">Table 5 Maintenance Activities and Intervals for Sudden Pressure Relaying</p> <p style="text-align: center;">Note: In cases where Components of Sudden Pressure Relaying are common to Components listed in Table 1-5, the Components only need to be tested once during a distinct maintenance interval.</p>		
Component Attributes	Maximum Maintenance Interval	Maintenance Activities
Any fault pressure relay.	6 Calendar Years	Verify the pressure or flow sensing mechanism is operable.
Electromechanical lockout devices which are directly in a trip path from the fault pressure relay to the interrupting device trip coil (regardless of any monitoring of the control circuitry).	6 Calendar Years	Verify electrical operation of electromechanical lockout devices.
Unmonitored control circuitry associated with Sudden Pressure Relaying.	12 Calendar Years	Verify all paths of the trip circuits inclusive of all auxiliary relays through the trip coil(s) of the circuit breakers or other interrupting devices.
Control circuitry associated with Sudden Pressure Relaying whose integrity is monitored and alarmed (See Table 2).	No periodic maintenance specified	None.

PRC-005 — Attachment A

Criteria for a Performance-Based Protection System Maintenance Program

Purpose: To establish a technical basis for initial and continued use of a performance-based Protection System Maintenance Program (PSMP).

To establish the technical justification for the initial use of a performance-based PSMP:

1. Develop a list with a description of Components included in each designated Segment, with a minimum Segment population of 60 Components.
2. Maintain the Components in each Segment according to the time-based maximum allowable intervals established in Tables 1-1 through 1-5, Table 3, Tables 4-1 through 4-2, and Table 5 until results of maintenance activities for the Segment are available for a minimum of 30 individual Components of the Segment.
3. Document the maintenance program activities and results for each Segment, including maintenance dates and Countable Events for each included Component.
4. Analyze the maintenance program activities and results for each Segment to determine the overall performance of the Segment and develop maintenance intervals.
5. Determine the maximum allowable maintenance interval for each Segment such that the Segment experiences Countable Events on no more than 4% of the Components within the Segment, for the greater of either the last 30 Components maintained or all Components maintained in the previous year.

To maintain the technical justification for the ongoing use of a performance-based PSMP:

1. At least annually, update the list of Components and Segments and/or description if any changes occur within the Segment.
2. Perform maintenance on the greater of 5% of the Components (addressed in the performance based PSMP) in each Segment or 3 individual Components within the Segment in each year.
3. For the prior year, analyze the maintenance program activities and results for each Segment to determine the overall performance of the Segment.
4. Using the prior year's data, determine the maximum allowable maintenance interval for each Segment such that the Segment experiences Countable Events on no more than 4% of the Components within the Segment, for the greater of either the last 30 Components maintained or all Components maintained in the previous year.

If the Components in a Segment maintained through a performance-based PSMP experience 4% or more Countable Events, develop, document, and implement an action plan to reduce the Countable Events to less than 4% of the Segment population within 3 years.

Rationale:

During development of this standard, text boxes were embedded within the standard to explain the rationale for various parts of the standard. Upon BOT approval, the text from the rationale text boxes was moved to this section.

Rationale for Applicability Section:

This section does not reflect the applicability changes that will be proposed by the Project 2014-01 Standards Applicability for Dispersed Generation Resources standards drafting team. The changes in this posted version and those being made by the Project 2014-01 standards drafting team do not overlap.

Additionally, to align with ongoing NERC standards development in Project 2010-05.2: Special Protection Systems, the term “Special Protection Systems” in PRC-005-4 was replaced by the term “Remedial Action Schemes.” These terms are synonymous in the NERC Glossary of Terms.

Rationale for the deletion of part of the definition of Component:

The SDT determined that it was explanatory in nature and adequately addressed in the Supplementary Reference and FAQ Document.

Rationale for R3 Part 3.1:

In the last posting, the SDT included language in the standard that was originally in the implementation plan that required completion of maintenance activities within three years for newly-identified Automatic Reclosing Components following a notification under Requirement R6, which has been removed. After further discussion, the SDT determined that a separate shorter timeframe for maintenance of newly-identified Automatic Reclosing Components created unnecessary complication within the standard. The SDT agreed that entities should be responsible for maintaining the Automatic Reclosing Components subject to the standard, whether existing, newly added or newly within scope based on a change in the largest generating unit in the BA or, if a member of a Reserve Sharing Group, the largest generating unit within the Reserve Sharing Group according to the timeframes in the maintenance tables. Therefore, 3.1 and its subparts have been removed and have not been reinserted into the implementation plan.

Rationale for R4 Part 4.1:

In the last posting, the SDT included language in the standard that was originally in the implementation plan that required completion of maintenance activities within three years for newly-identified Automatic Reclosing Components following a notification under Requirement R6, which has been removed. After further discussion, the SDT determined that a separate shorter timeframe for maintenance of newly-identified Automatic Reclosing Components created unnecessary complication within the standard. The SDT agreed that entities should be responsible for maintaining the Automatic Reclosing Components subject to the standard, whether existing, newly added or newly within scope based on a change in the largest generating unit in the BA or, if a member of a Reserve Sharing Group, the largest generating

unit within the Reserve Sharing Group according to the timeframes in the maintenance tables. Therefore, 4.1 and its subparts have been removed and have not been reinserted into the implementation plan.

Rationale for section 4.2.5:

These applicability revisions are intended to clarify and provide for consistent application of the Requirements to BES generator Facilities included in the BES through Inclusion I4 – Dispersed Power Producing Resources. The SDT modified the language for clarity based on comments received and is not changing the intent of the standard modification from the last posted version of this standard.

Exhibit B

Implementation Plans

Exhibit B-1a

Implementation Plan PRC-005-6

Implementation Plan

Project 2007-17.4 PRC-005 FERC Order No. 803 Directive
PRC-005-6

Standards Involved

Approval:

- PRC-005-6 – Protection System, Automatic Reclosing, and Sudden Pressure Relaying Maintenance

Retirement:

- PRC-005-5 – Protection System, Automatic Reclosing, and Sudden Pressure Relaying Maintenance
- PRC-005-4 Protection System, Automatic Reclosing, and Sudden Pressure Relaying Maintenance
- PRC-005-3 (ii) Protection System and Automatic Reclosing Maintenance
- PRC-005-3 (i) Protection System and Automatic Reclosing Maintenance
- PRC-005-3 Protection System and Automatic Reclosing Maintenance
- PRC-005-2 (ii) Protection System Maintenance
- PRC-005-2 (i) Protection System Maintenance
- PRC-005-1.1b – Transmission and Generation Protection System Maintenance and Testing
- PRC-008-0 – Implementation and Documentation of Underfrequency Load Shedding Equipment Maintenance Program
- PRC-011-0 – Undervoltage Load Shedding System Maintenance and Testing
- PRC-017-0 – Special Protection System Maintenance and Testing

Prerequisite Approvals:

N/A

Background:

In Order No. 803, FERC approved Standard PRC-005-3 and, in Paragraph 31, directed NERC to:

"...develop modifications to PRC-005-3 to include supervisory devices associated with auto-reclosing relay schemes to which the Reliability Standard applies. Further, we clarify that NERC's proposal regarding the scope of supervisory devices is an acceptable approach to satisfy the Commission directive. Specifically, NERC proposed in its NOPR comments, and we find acceptable, that the scope of the supervisory devices to be encompassed in the Reliability Standard are those providing voltage supervision, supervisory inputs associated with selective autoreclosing, and sync-check relays that are part of a reclosing scheme covered by PRC-005-3."

This Implementation Plan addresses:

- The implementation of changes relating to maintenance and testing of supervisory relays and associated voltage sensing devices related to Automatic Reclosing.
- The phased implementation approach included in the approved PRC-005-2(i) (PRC-005-2 has been retired by PRC-005-2(ii)) will remain as-is and is carried forward and incorporated by reference.
- Because PRC-005-6 incorporates all revisions to date, this implementation plan will supersede the implementation plans for PRC-005-2(ii), PRC-005-3, PRC-005-3(i), PRC-005-3(ii), PRC-005-4 and PRC-005-5 when PRC-005-6 becomes effective. PRC-005-2(i) will remain in effect and not be retired until entities are required to be compliant with R1, R2, and R5 of the PRC-005-6 standard under this implementation plan.

The Implementation Plan reflects consideration of the following:

1. The requirements set forth in the proposed standard, which carry forward requirements from PRC-005-2, PRC-005-2(i), PRC-005-2(ii), PRC-005-3, PRC-005-3(i), PRC-005-3(ii), PRC-005-4 and PRC-005-5, establish minimum maintenance activities for Protection System, Automatic Reclosing, and Sudden Pressure Relaying Component Types as well as the maximum allowable maintenance intervals for these maintenance activities.
2. The maintenance activities established in the various PRC-005 versions may not be presently performed by some registered entities and the established maximum allowable intervals may be shorter than those currently in use by some entities. Therefore, registered entities may not be presently performing a maintenance activity or may be using longer intervals than the maximum allowable intervals established in the PRC-005 standards. For these registered entities, it is unrealistic to become immediately compliant with the new activities or intervals. Further, registered entities should be allowed to become compliant in such a way as to facilitate a continuing PRC-005 maintenance program. The registered entities that have previously been

performing maintenance within the newly specified intervals may not have all the documentation needed to demonstrate compliance with all of the maintenance activities specified.

3. The implementation schedule set forth below carries forward and incorporates by reference the implementation schedules contained in the currently-effective PRC-005-2(i) implementation plan (which in turn incorporates by reference the PRC-005-2 implementation plan)), and combines the implementation schedules for PRC-005-2(ii), PRC-005-3, PRC-005-3(i), PRC-005-3(ii), PRC-005-4 and PRC-005-5. In addition, the implementation schedule includes changes needed to address the addition of Automatic Reclosing supervisory relays and associated voltage sensing devices in PRC-005-6.

General Considerations:

Each Transmission Owner, Generator Owner, and Distribution Provider shall maintain documentation to demonstrate compliance with PRC-005-1.1b, PRC-008-0, PRC-011-0, and PRC-017-0 until that entity meets all of the requirements of the currently effective PRC-005-2(i), or its combined successor standards, in accordance with this implementation plan.

While registered entities are implementing the requirements of PRC-005-2(i) or its combined successor standards, each registered entity must be prepared to identify whether its applicable Protection System, Automatic Reclosing, and Sudden Pressure Relaying Components were last maintained according to PRC-005-2(i) (or its combined successor standards), PRC-005-1.1b, PRC-008-0, PRC-011-0, PRC-017-0, or a combination thereof.

Effective Date

PRC-005-6 shall become effective on the first day of the first calendar quarter after the date that the standard is approved by an applicable governmental authority or as otherwise provided for in a jurisdiction where approval by an applicable governmental authority is required for a standard to go into effect. Where approval by an applicable governmental authority is not required, the standard shall become effective on the first day of the first calendar quarter after the date the standard is adopted by the NERC Board of Trustees or as otherwise provided for in that jurisdiction.

Retirement of Existing Standards:

Standards PRC-005-1.1b, PRC-008-0, PRC-011-0, and PRC-017-0 shall remain enforceable throughout the phased implementation period set forth in the PRC-005-2(i) implementation plan, incorporated herein by reference, and shall be applicable to a registered entity's Protection System Component maintenance activities not yet transitioned to PRC-005-2(i) or its combined successor standards. Standards PRC-005-1.1b, PRC-008-0, PRC-011-0, and PRC-017-0 shall be retired at midnight of March 31, 2027 or as otherwise made effective pursuant to the laws applicable to such Electric Reliability Organization (ERO) governmental authorities; or, in those jurisdictions where no regulatory approval is required, at midnight of March 31, 2027.

PRC-005-2(i) shall be retired at midnight of the day immediately prior to the first day of the first calendar quarter that is twelve (12) calendar months following applicable regulatory approval of PRC-005-6, or as otherwise made effective pursuant to the laws applicable to such ERO governmental authorities; or, in those jurisdictions where no regulatory approval is required, the first day of the first calendar quarter following the date of Board of Trustees' adoption.

If approved by the applicable ERO governmental authority prior to the approval of PRC-005-6, PRC-005-2(ii), PRC-005-3, PRC-005-3(i), PRC-005-3(ii), PRC-005-4 and PRC-005-5 shall be retired on the date immediately prior to the first day of the first calendar quarter following regulatory approval of PRC-005-6.

Implementation Plan for Definitions:

This section includes all newly defined or revised terms used in the proposed standard. Terms already defined in the Reliability Standards Glossary of Terms (Glossary) are not repeated here. New or revised definitions listed below become approved when the proposed standard is approved by applicable governmental authority or as otherwise provided for in a jurisdiction where approval by an applicable governmental authority is required for a standard to go into effect. When the standard becomes effective, the Glossary definition will be removed from the individual standard and added to the Glossary. The definitions of terms used only in the standard will remain in the standard.

Glossary Definition:

Protection System Maintenance Program (PSMP) - An ongoing program by which Protection System, Automatic Reclosing, and Sudden Pressure Relaying Components are kept in working order and proper operation of malfunctioning Components is restored. A maintenance program for a specific Component includes one or more of the following activities:

- Verify — Determine that the Component is functioning correctly.
- Monitor — Observe the routine in-service operation of the Component.
- Test — Apply signals to a Component to observe functional performance or output behavior, or to diagnose problems.
- Inspect — Examine for signs of Component failure, reduced performance or degradation.
- Calibrate — Adjust the operating threshold or measurement accuracy of a measuring element to meet the intended performance requirement.

Definitions of Terms Used in the Standard:

Automatic Reclosing – Includes the following Components:

- Reclosing relay

- Supervisory relay(s) or function(s) – relay(s) or function(s) that perform voltage and/or sync check functions that enable or disable operation of the reclosing relay
- Voltage sensing devices associated with the supervisory relay(s)
- Control circuitry associated with the reclosing relay or supervisory relay(s)

Component Type –

- Any one of the five specific elements of a Protection System.
- Any one of the four specific elements of Automatic Reclosing.
- Any one of the two specific elements of Sudden Pressure Relaying.

Component – Any individual discrete piece of equipment included in a Protection System, Automatic Reclosing, or Sudden Pressure Relaying.

Countable Event – A failure of a Component requiring repair or replacement, any condition discovered during the maintenance activities in Tables 1-1 through 1-5, Table 3, Tables 4-1 through 4-3, and Table 5, which requires corrective action or a Protection System Misoperation attributed to hardware failure or calibration failure. Misoperations due to product design errors, software errors, relay settings different from specified settings, Protection System Component, Automatic Reclosing, or Sudden Pressure Relaying configuration or application errors are not included in Countable Events.

Sudden Pressure Relaying – A system that trips an interrupting device(s) to isolate the equipment it is monitoring and includes the following Components:

- Fault pressure relay – a mechanical relay or device that detects rapid changes in gas pressure, oil pressure, or oil flow that are indicative of Faults within liquid-filled, wire-wound equipment
- Control circuitry associated with a fault pressure relay

Implementation Plan for New or Revised Definitions:

The revised definitions (Protection System Maintenance Program, Automatic Reclosing, Component Type, Component, Countable Event and Sudden Pressure Relaying) become effective upon the effective date of PRC-005-6.

Implementation Plan for PRC-005-2(i) and PRC-005-6

All Components with existing requirements under currently effective PRC-005-2(i) will continue to follow the PRC-005-2(i) implementation plan, which is incorporated herein by reference. Those

Components and/or Facilities newly introduced by PRC-005-2(ii),* PRC-005-3, PRC-005-3(i), PRC-005-3(ii),* PRC-005-4, PRC-005-5 and PRC-005-6 (including Sudden Pressure Relaying, Automatic Reclosing Components, and dispersed generation resources) will be covered by the following Implementation Plan:

Requirements R1, R2, and R5:

PRC-005-6: For Automatic Reclosing Components, Sudden Pressure Relaying Components, and dispersed generation resources, entities shall be 100% compliant on the first day of the first calendar quarter twelve (12) months following applicable regulatory approvals of PRC-005-6 or, in those jurisdictions where no regulatory approval is required, on the first day of the first calendar quarter twenty-four (24) months following NERC Board of Trustees' adoption of PRC-005-6 or as otherwise made effective pursuant to the laws applicable to such ERO governmental authorities.

Implementation Plan for Requirements R3 and R4:

PRC-005-6:

1. For Automatic Reclosing Components, Sudden Pressure Relaying Components, and dispersed generation resources maintenance activities with maximum allowable intervals of six (6) calendar years, as established in Tables 4-1, 4-2(a), 4-2(b), 4-3, and 5:
 - The entity shall be at least 30% compliant on the first day of the first calendar quarter thirty-six (36) months following applicable regulatory approval of PRC-005-6 (or, for generating plants with scheduled outage intervals exceeding three years, at the conclusion of the first succeeding maintenance outage) or, in those jurisdictions where no regulatory approval is required, on the first day of the first calendar quarter forty-eight (48) months following NERC Board of Trustees' adoption of PRC-005-6 or as otherwise made effective pursuant to the laws applicable to such ERO governmental authorities.
 - The entity shall be at least 60% compliant on the first day of the first calendar quarter sixty (60) months following applicable regulatory approval of PRC-005-6 or, in those jurisdictions where no regulatory approval is required, on the first day of the first calendar quarter seventy-two (72) months following NERC Board of Trustees' adoption of PRC-005-6, or as otherwise made effective pursuant to the laws applicable to such ERO governmental authorities.
 - The entity shall be 100% compliant on the first day of the first calendar quarter eighty-four (84) months following applicable regulatory approval of PRC-005-6 or, in those jurisdictions where no regulatory approval is required, on the first day of the first calendar quarter ninety-six (96) months following NERC Board of Trustees' adoption of PRC-005-6 or as otherwise made effective pursuant to the laws applicable to such ERO governmental authorities.

*The proposed Implementation Plan for the Revised Definition of "Remedial Action Scheme" developed as part of Project 2010-05.2 – Special Protection Systems shall continue to govern implementation of the revised Remedial Action Scheme definition, including implementation for entities with newly classified "Remedial Action Scheme."

2. For Automatic Reclosing Components, Sudden Pressure Relaying Components, and dispersed generation resources maintenance activities, with maximum allowable intervals of twelve (12) calendar years, as established in Table 4-1, 4.2(a), 4.2(b), 4-3, and 5:
- The entity shall be at least 30% compliant on the first day of the first calendar quarter sixty (60) months following applicable regulatory approval of PRC-005-6 or, in those jurisdictions where no regulatory approval is required, on the first day of the first calendar quarter seventy-two (72) months following NERC Board of Trustees' adoption of PRC-005-6 or as otherwise made effective pursuant to the laws applicable to such ERO governmental authorities.
 - The entity shall be at least 60% compliant on the first day of the first calendar quarter following one hundred eight (108) months following applicable regulatory approval of PRC-005-6 or, in those jurisdictions where no regulatory approval is required, on the first day of the first calendar quarter one hundred twenty (120) months following NERC Board of Trustees' adoption of PRC-005-6 or as otherwise made effective pursuant to the laws applicable to such ERO governmental authorities.
 - The entity shall be 100% compliant on the first day of the first calendar quarter one hundred fifty-six (156) months following applicable regulatory approval of PRC-005-6 or, in those jurisdictions where no regulatory approval is required, on the first day of the first calendar quarter one hundred sixty-eight (168) months following NERC Board of Trustees' adoption of PRC-005-6 or as otherwise made effective pursuant to the laws applicable to such ERO governmental authorities.

Applicability:

This standard applies to the following functional entities:

- Transmission Owner
- Generator Owner
- Distribution Provider

Exhibit B-1b

Implementation Plan Rationale PRC-005-6

Alignment of PRC-005 Compliance Dates

I. PRC-005 Compliance Issue and Proposal to Align Compliance Dates

Since the approval of PRC-005-2, a number of standards development projects have resulted in either including or excluding devices from the scope of PRC-005. Currently, there are eight approved or currently proposed PRC-005 versions, and each Version comes with a separate implementation schedule. Version PRC-005-2(i) is the current mandatory and enforceable version as of the date of this posting. Depending on the type of device and specific requirement in some of the PRC-005 versions, the implementation is divided into phases, requiring registered entities to gradually ensure compliance of a percentage of their devices until they reach 100% compliance.

Versions -3, -4, and -6 will require three consecutive updates to the registered entities' Protection System Maintenance Programs (PSMP), which is expected to be a time-consuming task for many entities. Based on the implementation plans for these three versions, the required PSMP updates would have to be completed within one (1) year to eighteen (18) months. According to the PRC-005 drafting team, which represents various industry members, this short period of time for review and identification of all assets subject to the revised PRC-005 versions could lead to errors and misidentification of devices. Further, the existence of eight implementation plans could lead to misinterpretations and inconsistencies in the compliance and auditing practices throughout the Electric Reliability Organization (ERO) Enterprise.

To address this compliance issue, the PRC-005 drafting team requested that NERC align the effective dates of all outstanding PRC-005 Versions, thus simplifying the implementation schedule for this Reliability Standard. In response to the drafting team's request, NERC plans to petition the Federal Energy Regulatory Commission (FERC) to delay the implementation of approved versions PRC-005-3 and PRC-005-4. Because PRC-005-6 reflects the new applicability that has been introduced by PRC-005-2(ii), PRC-005-3, PRC-005-3(i), PRC-005-3(ii), PRC-005-4, PRC-005-5, and PRC-005-6, when PRC-005-6 becomes effective, all new applicability will become effective and aligned to the same dates. NERC proposes that the phased in implementation of PRC-005-2 continue in accordance with the PRC-005-2 implementation plan, which is incorporated by reference into the implementation plan for currently-effective PRC-005-2(i). The phased implementation approach will remain but the effective dates for each phase will align applicability.

This proposal is reflected in the implementation plan for PRC-005-6. If supported by industry members and adopted by the NERC Board of Trustees, the implementation plan will be included in the PRC-005-6 petition to be filed with FERC for approval.

II. PRC-005 Versions Overview

The draft PRC-005-6 incorporates all revisions made to PRC-005-2 as a result of the development of PRC-005-2(i) (the currently-effective version), PRC-005-2(ii), PRC-005-3, PRC-005-3(i), PRC-005-3(ii), PRC-005-4, and PRC-005-5, and PRC-005-6. Version -3 added Automatic Reclosing devices; versions 2(i), 3(i), and -5 exclude individual dispersed generation resources from the applicability of the standard; versions 2(ii) and 3(ii) replace the term "Special Protection System" with the term "Remedial Action Scheme"; version -4 added Sudden Pressure Relays; and version -6 will add supervisory relays and exclude individual dispersed generation resources from the applicability of this Reliability Standard.

From this list of all PRC-005 versions, versions 2(i), 3, 3(i), and 4 are approved by FERC; PRC-005-2(ii) and PRC-005-3(ii) are pending regulatory approval; PRC-005-5 has not yet been filed for approval with FERC; and PRC-005-6 is currently under development.

III. Impact on the Reliability of the Bulk Power System and on Compliance with PRC-005

Based on the implementation schedule for the FERC-approved PRC-005-3, PRC-005-3(i), and PRC-005-4, and estimated approval and effective dates for the remaining versions, the delay in the implementation of PRC-005-3 and PRC-005-4 created by this proposal is anticipated to be approximately one year.

The proposed changes described here and in the proposed PRC-005-6 implementation plan will not affect the immediate implementation of version 2(i). This version excludes certain dispersed generation resources from the definition of Bulk Electric System, and from the applicability of PRC-005. Thus, registered entities that own and operate dispersed generation resources will remain unaffected by the proposed changes.

PRC-005-2(ii) and PRC-005-3(ii), which as of this writing are pending before the Commission, reflect enhancements to the NERC Glossary of Terms related to Special Protection Systems and Remedial Action Schemes. A potential delay in implementation of the revised definition of Remedial Action Scheme would not present a risk to the reliability of the Bulk Power System (BPS). Finally, the anticipated changes related to Remedial Action Schemes are minor in nature and are unlikely to introduce an actual reliability risk.

Because the Automatic Reclosing devices and Sudden Pressure Relays brought in by versions -3 and -4 are limited in scope, a potential delay in the implementation of these versions of PRC-005 is also unlikely to increase risk to the BPS. Many of these devices are already monitored by industry in anticipation of the upcoming compliance requirements, but may not be specifically included in the registered entities' PSMPs at this time.

IV. Benefits to Registered Entities

The proposal aims to simplify the compliance efforts of all registered entities subject to PRC-005 and give industry additional time to comply with versions -3, -4, and -6, which require PSMP updates. Having PRC-005-2(ii), PRC-005-3, PRC-005-3(i), PRC-005-3(ii), PRC-005-4, PRC-005-5, and PRC-005-6 essentially become effective at the same time through a single, unified PRC-005-6 Reliability Standard and associated implementation plan minimizes the possibility of misinterpretations of multiple PRC-005 versions and associated compliance obligations, thus limiting the compliance risk for registered entities. In addition, the proposed changes will not affect the anticipated exclusion of certain dispersed generation resources from the scope of the standard.

To further facilitate compliance, NERC plans to use the additional time until PRC-005-6 becomes effective to conduct outreach and provide training to ensure that registered entities are well aware and prepared to meet their obligations under the various PRC-005 versions.

Effective Date Information

Table 1 provides information regarding each version of the PRC-005 standard.

Table 1: PRC-005 Effective Date Information		
Standard	Effective Date ¹	Comments
PRC-005-2	April 1, 2015	
PRC-005-2(i)	May 29, 2015	Proposed effective date with version 2, which was immediately following FERC approval.
PRC-005-2(ii)	Filed and Pending Regulatory Approval	Proposed to be deferred; will be replaced with version 6. ²
PRC-005-3	April 1, 2016	Proposed to be deferred; will be replaced with version 6.
PRC-005-3(i)	April 1, 2016	Proposed to be deferred; will be replaced with version 6.
PRC-005-3(ii)	Filed and Pending Regulatory Approval	Proposed to be deferred; will be replaced with version 6.
PRC-005-4	January 1, 2016	Proposed to be deferred; will be replaced with version 6.
PRC-005-5	Pending Regulatory Filing	Proposed to be deferred; will be replaced with version 6.
PRC-005-6	Pending Regulatory Filing	TBD

¹ The effective date listed is the start date of when the standard becomes effective. This does not include the phased in approach.

² The effective date is dependent on when FERC approves PRC-005-6, which could be from three (3) months to one (1) year after submittal of the petition for approval.

Exhibit B-2

Implementation Plan PRC-005-5 (Alternative)

Implementation Plan

Project 2014-01 Standards Applicability for Dispersed Power Producing Resources PRC-005-5

Standards Involved

Approval:

- PRC-005-5 – Protection System, Automatic Reclosing, and Sudden Pressure Relaying Maintenance

Retirement:

- PRC-005-4 – Protection System, Automatic Reclosing, and Sudden Pressure Relaying Maintenance

Prerequisite Approvals

N/A

Background

In light of the adoption of a revised “Bulk Electric System” definition by the NERC Board of Trustees (Board), changes to the applicability sections of certain Reliability Standards, including PRC-005, are necessary to align with the implementation of the revised BES definition. The Dispersed Generation Resources Standard Drafting Team (DGR SDT) for Project 2014-01 – Standards Applicability for Dispersed Power Producing Resources has modified the applicability section of certain Generator Owner/Generator Operator requirements to recognize the unique technical and reliability aspects of dispersed power producing resources in order to ensure the applicability of the standards is consistent with the reliable operation of the BES.

General Considerations

Reliability Standard PRC-005-4, with its associated Implementation Plan, was adopted by the Board on November 13, 2014. The DGR SDT has revised the applicability section of PRC-005-4 to align the standard with the revised definition of the BES.

Effective Date

PRC-005-5 shall become effective on the later of the first day following the Effective Date of PRC-005-4 or the first day following approval by an applicable governmental authority or as otherwise provided for in a jurisdiction where approval by an applicable governmental authority is required for a standard to go into effect. Where approval by an applicable governmental authority is not required, the standard shall

become effective on the later of the first day following the Effective Date of PRC-005-4 or the first day of the first calendar quarter after the date the standard is adopted by the Board or as otherwise provided for in that jurisdiction.

Retirement of Existing Standards

PRC-005-4 shall be retired at midnight of the day immediately prior to the Effective Date of PRC-005-5 in the particular jurisdiction in which the revised standard is becoming effective.

Implementation Plan

PRC-005-5 only modifies the applicability for PRC-005-4. All aspects of the Implementation Plan for PRC-005-4 will remain applicable to PRC-005-5 and are incorporated here by reference.

Cross References

The Implementation Plan for the revised definition of “Bulk Electric System” is available [here](#).

The Implementation Plan for PRC-005-4 is available [here](#).

Exhibit C

Order No. 672 Criteria

Order No. 672 Criteria

In Order No. 672,² the Commission identified a number of criteria it will use to analyze Reliability Standards proposed for approval to ensure they are just, reasonable, not unduly discriminatory or preferential, and in the public interest. The discussion below identifies these factors and explains how the proposed Reliability Standard has met or exceeded the criteria:

1. Proposed Reliability Standards must be designed to achieve a specified reliability goal and must contain a technically sound means to achieve that goal.³

The purpose of proposed Reliability Standards PRC-005-5 and PRC-005-6 is to document and implement programs for the maintenance of all Protection Systems, Automatic Reclosing, and Sudden Pressure Relaying affecting the reliability of the Bulk Electric System (BES) so that they are kept in working order. Proposed Reliability Standard PRC-005-5 enhances reliability by ensuring that owners and operators of dispersed generation resources are appropriately subject to the requirements of the PRC-005 standard, consistent with prior approved and currently-effective versions of the PRC-005 standard. The DGR White Paper (**Exhibit D**), provides a detailed description of the standard drafting team considerations for these applicability revisions.

¹ In the petition, NERC requests approval of proposed PRC-005-6 and requests that, if the Commission declines to approve PRC-005-6, the Commission approve PRC-005-5 in the alternative. Therefore, this discussion addresses how both PRC-005-5 and PRC-005-6 meet the criteria for governmental approval as set forth in Order No. 672.

² *Rules Concerning Certification of the Electric Reliability Organization; and Procedures for the Establishment, Approval, and Enforcement of Electric Reliability Standards*, Order No. 672, FERC Stats. & Regs. ¶ 31,204, *order on reh'g*, Order No. 672-A, FERC Stats. & Regs. ¶ 31,212 (2006).

³ Order No. 672 at P 321. The proposed Reliability Standard must address a reliability concern that falls within the requirements of section 215 of the FPA. That is, it must provide for the reliable operation of Bulk-Power System facilities. It may not extend beyond reliable operation of such facilities or apply to other facilities. Such facilities include all those necessary for operating an interconnected electric energy transmission network, or any portion of that network, including control systems. The proposed Reliability Standard may apply to any design of planned additions or modifications of such facilities that is necessary to provide for reliable operation. It may also apply to Cybersecurity protection.

Proposed PRC-005-6 revises proposed PRC-005-5 to add detailed information regarding minimum maintenance activities and maximum maintenance intervals for supervisory devices associated with Automatic Reclosing, extending the benefits of a strong maintenance program to those Components and thereby satisfying the Commission's directive in Order No. 803.⁴ The scope of supervisory devices included in proposed PRC-005-6 is based on the findings of the SAMS/SPCS Report, attached hereto as **Exhibit H**, and was found acceptable by the Commission in Order No. 803.⁵

2. Proposed Reliability Standards must be applicable only to users, owners and operators of the bulk power system, and must be clear and unambiguous as to what is required and who is required to comply.⁶

The proposed Reliability Standards are clear and unambiguous as to what is required and who is required to comply, in accordance with Order No. 672.

Proposed Reliability Standard PRC-005-5 carries forward a clarification made to the applicability of PRC-005 to dispersed power producing resources (also called dispersed generation resources), consistent with prior Commission-approved revisions to the PRC-005 standard. Proposed Reliability standard PRC-005-6 revises proposed PRC-005-5 to include supervisory devices associated with applicable autoreclosing relay schemes within the scope of the standard. Aside from minor modifications to facilitate coverage of these devices and promote

⁴ *Protection System Maintenance Reliability Standard*, Order No. 803, 150 FERC 61,039 at P 31 (2015) ("Order No. 803").

⁵ See Order No. 803 at P 31 ("Specifically, NERC proposed in its NOPR comments, and we find acceptable, that the scope of the supervisory devices to be encompassed in the Reliability Standard are those providing voltage supervision, supervisory inputs associated with selective autoreclosing, and sync-check relays that are part of a reclosing scheme covered by PRC-005-3.").

⁶ Order No. 672 at P 322. The proposed Reliability Standard may impose a requirement on any user, owner, or operator of such facilities, but not on others.

Order No. 672 at P 325. The proposed Reliability Standard should be clear and unambiguous regarding what is required and who is required to comply. Users, owners, and operators of the Bulk-Power System must know what they are required to do to maintain reliability.

readability, the Requirements previously-approved by the Commission in PRC-005-4 remain unchanged.

The proposed Reliability Standards apply to Generator Owners, Transmission Owners, and Distribution Providers and clearly articulate the actions that each entity must take to comply with the proposed Reliability Standards.

3. A proposed Reliability Standard must include clear and understandable consequences and a range of penalties (monetary and/or non-monetary) for a violation.⁷

The Violation Risk Factors (“VRFs”) and Violation Severity Levels (“VSLs”) for the proposed Reliability Standards comport with NERC and Commission guidelines related to their assignment. The assignment of the severity level for each VSL is consistent with the corresponding requirement. The VSLs do not use any ambiguous terminology, thereby supporting uniformity and consistency in the determination of similar penalties for similar violations. For these reasons, the proposed Reliability Standards include clear and understandable consequences in accordance with Order No. 672.

Because the Requirements contained in proposed PRC-005-5 track with those contained in the already approved or proposed versions of the PRC-005 Reliability Standards, the Project 2014-01 Standards Applicability for Dispersed Generation Resources standard drafting team determined that no revisions were necessary to the VSLs and VRFs for proposed PRC-005-5.

With respect to proposed Reliability Standard PRC-005-6, because the Requirements contained track with those contained in the previous versions, the Project 2007-17.4 PRC-005 FERC Order No. 803 Directive standard drafting team determined that no revisions were necessary to the VRFs. NERC, therefore, requests that the Commission approve the VRFs as

⁷ Order No. 672 at P 326. The possible consequences, including range of possible penalties, for violating a proposed Reliability Standard should be clear and understandable by those who must comply.

applied to the supervisory relay devices now included in the proposed Reliability Standard as Automatic Reclosing Components.

The VSLs in PRC-005-6 have been revised accordingly to address the supervisory relay devices now included in the proposed Reliability Standard in the levels of severity. The changes are consistent with the approach taken for the VSLs in Reliability Standard PRC-005-4.

A detailed review of the proposed PRC-005-6 VRFs, VSLs, and the analysis of how the VRFs and VSLs were determined using these guidelines is provided in **Exhibit G**.

4. A proposed Reliability Standard must identify clear and objective criterion or measure for compliance, so that it can be enforced in a consistent and non-preferential manner.⁸

The proposed Reliability Standards continue to include Measures that support the Requirements by clearly identifying what is required and how the Requirement will be enforced. The Measures have not changed since the approved Reliability Standard PRC-005-4, except that in PRC-005-6 Protection System Maintenance Program is abbreviated as “PSMP” for readability and the table references are updated to include the addition of a new table to address supervisory devices. The proposed Measures are as follows:

M1. Each Transmission Owner, Generator Owner and Distribution Provider shall have a documented PSMP in accordance with Requirement R1.

For each Protection System, Automatic Reclosing, and Sudden Pressure Relaying Component Type, the documentation shall include the type of maintenance method applied (time-based, performance-based, or a combination of these maintenance methods), and shall include all batteries associated with the station dc supply Component Types in a time-based program as described in Table 1-4 and Table 3. (Part 1.1)

For Component Types that use monitoring to extend the maintenance intervals, the responsible entity(s) shall have evidence for each Protection System, Automatic Reclosing, and Sudden Pressure Relaying Component Type (such as manufacturer’s

⁸ Order No. 672 at P 327. There should be a clear criterion or measure of whether an entity is in compliance with a proposed Reliability Standard. It should contain or be accompanied by an objective measure of compliance so that it can be enforced and so that enforcement can be applied in a consistent and non-preferential manner.

specifications or engineering drawings) of the appropriate monitored Component attributes as specified in Tables 1-1 through 1-5, Table 2, Table 3, Table 4-1 through 4-3, and Table 5. (Part 1.2)

M2. Each Transmission Owner, Generator Owner, and Distribution Provider that uses performance-based maintenance intervals shall have evidence that its current performance-based maintenance program(s) is in accordance with Requirement R2, which may include, but is not limited to, Component lists, dated maintenance records, and dated analysis records and results.

M3. Each Transmission Owner, Generator Owner, and Distribution Provider that utilizes time-based maintenance program(s) shall have evidence that it has maintained its Protection System, Automatic Reclosing, and Sudden Pressure Relaying Components included within its time-based program in accordance with Requirement R3. The evidence may include, but is not limited to, dated maintenance records, dated maintenance summaries, dated check-off lists, dated inspection records, or dated work orders.

M4. Each Transmission Owner, Generator Owner, and Distribution Provider that utilizes performance-based maintenance intervals in accordance with Requirement R2 shall have evidence that it has implemented the PSMP for the Protection System, Automatic Reclosing, and Sudden Pressure Relaying Components included in its performance-based program in accordance with Requirement R4. The evidence may include, but is not limited to, dated maintenance records, dated maintenance summaries, dated check-off lists, dated inspection records, or dated work orders.

M5. Each Transmission Owner, Generator Owner, and Distribution Provider shall have evidence that it has undertaken efforts to correct identified Unresolved Maintenance Issues in accordance with Requirement R5. The evidence may include, but is not limited to, work orders, replacement Component orders, invoices, project schedules with completed milestones, return material authorizations (RMAs) or purchase orders.

These Measures help provide clarity regarding how the Requirements will be enforced, and help ensure that the Requirements will be enforced in a clear, consistent, and non-preferential manner and without prejudice to any party.

5. Proposed Reliability Standards should achieve a reliability goal effectively and efficiently — but do not necessarily have to reflect “best practices” without regard

to implementation cost or historical regional infrastructure design.⁹

The proposed Reliability Standard achieves its reliability goals effectively and efficiently in accordance with Order No. 672. Proposed Reliability Standard PRC-005-5 improves reliability by ensuring the equipment utilized to aggregate individual dispersed generation resources to a common point of interconnection with the Bulk-Power System is maintained as required by the PRC-005 standard. Proposed Reliability Standard PRC-005-6 improves reliability by extending the protections of a strong Protection System Maintenance Program to supervisory devices associated with applicable autoreclosing relay schemes in accordance with Order No. 803.

6. Proposed Reliability Standards cannot be “lowest common denominator,” *i.e.*, cannot reflect a compromise that does not adequately protect Bulk-Power System reliability. Proposed Reliability Standards can consider costs to implement for smaller entities, but not at consequences of less than excellence in operating system reliability.¹⁰

The proposed Reliability Standards do not reflect a “lowest common denominator” approach. The changes reflected in proposed Reliability Standard PRC-005-5 are supported by the DGR White Paper in Exhibit D and determinations from the Project 2014-01 standard drafting team, are targeted to a specific issue, and balance the applicability of the coverage of proposed PRC-005-5 with the reliability needs specific to dispersed generation resources. The

⁹ Order No. 672 at P 328. The proposed Reliability Standard does not necessarily have to reflect the optimal method, or “best practice,” for achieving its reliability goal without regard to implementation cost or historical regional infrastructure design. It should however achieve its reliability goal effectively and efficiently.

¹⁰ Order No. 672 at P 329. The proposed Reliability Standard must not simply reflect a compromise in the ERO’s Reliability Standard development process based on the least effective North American practice —the so-called “lowest common denominator” — if such practice does not adequately protect Bulk-Power System reliability. Although FERC will give due weight to the technical expertise of the ERO, we will not hesitate to remand a proposed Reliability Standard if we are convinced it is not adequate to protect reliability.

Order No. 672 at P 330. A proposed Reliability Standard may take into account the size of the entity that must comply with the Reliability Standard and the cost to those entities of implementing the proposed Reliability Standard. However, the ERO should not propose a “lowest common denominator” Reliability Standard that would achieve less than excellence in operating system reliability solely to protect against reasonable expenses for supporting this vital national infrastructure. For example, a small owner or operator of the Bulk-Power System must bear the cost of complying with each Reliability Standard that applies to it.

changes reflected in proposed Reliability Standard PRC-005-6, in addition to satisfying a Commission reliability concern, require expanded application of maintenance plans and processes, helping to preserve reliability by addressing potential issues before they can have a negative impact. In identifying the appropriate supervisory devices to include within the PRC-005 standard, NERC reviewed the SAMS/SPCS report in Exhibit H and consulted with its internal subject matter experts. This resulted in an efficient and effective determination regarding the supervisory devices to be included as Automatic Reclosing Components in proposed PRC-005-6.

- 7. Proposed Reliability Standards must be designed to apply throughout North America to the maximum extent achievable with a single Reliability Standard while not favoring one geographic area or regional model. It should take into account regional variations in the organization and corporate structures of transmission owners and operators, variations in generation fuel type and ownership patterns, and regional variations in market design if these affect the proposed Reliability Standard.¹¹**

The proposed Reliability Standards apply throughout North America and do not favor one geographic area or regional model.

- 8. Proposed Reliability Standards should cause no undue negative effect on competition or restriction of the grid beyond any restriction necessary for reliability.¹²**

Proposed Reliability Standards PRC-005-5 and PRC-005-6 have no undue negative effect

¹¹ Order No. 672 at P 331. A proposed Reliability Standard should be designed to apply throughout the interconnected North American Bulk-Power System, to the maximum extent this is achievable with a single Reliability Standard. The proposed Reliability Standard should not be based on a single geographic or regional model but should take into account geographic variations in grid characteristics, terrain, weather, and other such factors; it should also take into account regional variations in the organizational and corporate structures of transmission owners and operators, variations in generation fuel type and ownership patterns, and regional variations in market design if these affect the proposed Reliability Standard.

¹² Order No. 672 at P 332. As directed by section 215 of the FPA, FERC itself will give special attention to the effect of a proposed Reliability Standard on competition. The ERO should attempt to develop a proposed Reliability Standard that has no undue negative effect on competition. Among other possible considerations, a proposed Reliability Standard should not unreasonably restrict available transmission capability on the Bulk-Power System beyond any restriction necessary for reliability and should not limit use of the Bulk-Power System in an unduly preferential manner. It should not create an undue advantage for one competitor over another.

on competition. The proposed Reliability Standards requires the same performance by each of the applicable Functional Entities—Generator Owners, Transmission Owners, and Distribution Providers—in requiring the development of maintenance plans to address Automatic Reclosing including applicable supervisory devices.

The proposed Reliability Standards do not unreasonably restrict the available generation or transmission capability or limit use of the Bulk-Power System in a preferential manner.

9. The implementation time for the proposed Reliability Standard is reasonable.¹³

The proposed effective dates for the proposed Reliability Standards are just and reasonable and appropriately balance the urgency in the need to implement the proposed Reliability Standards against the reasonableness of the time allowed for those who must comply to develop necessary procedures, software, facilities, staffing or other relevant capability. This will allow applicable entities adequate time to ensure compliance with the Requirements. The proposed effective dates are explained in the proposed implementation plans, attached as **Exhibit B (B-1a, B-2)**.

The proposed PRC-005-6 Implementation Plan is intended to facilitate an orderly and efficient transition from currently-effective PRC-005-2(i) to proposed PRC-005-6 and represents a significant improvement over the previous implementation approach for these standards, which would require multiple successive revisions to the Protection System Maintenance Programs, required by the PRC-005 standard to address newly applicable devices.

In the proposed implementation plan for PRC-005-6, NERC proposes to continue the phased implementation approach of the previous PRC-005 implementation plans. Depending on the type of device and specific requirement, implementation is divided into phases, requiring

¹³ Order No. 672 at P 333. In considering whether a proposed Reliability Standard is just and reasonable, FERC will consider also the timetable for implementation of the new requirements, including how the proposal balances any urgency in the need to implement it against the reasonableness of the time allowed for those who must comply to develop the necessary procedures, software, facilities, staffing or other relevant capability.

registered entities to gradually ensure compliance of a percentage of their devices until they reach 100% compliance. However, as multiple versions of the PRC-005 standard have now been approved by the Commission and are pending enforcement, NERC proposes to align the dates by which entities must be compliant for all new applicable systems. Although this approach would require a slight delay in implementing requirements for new applicable systems introduced by previous PRC-005 versions, it would provide several important benefits. First, this approach would advance reliability by allowing entities sufficient time to address all new devices, thereby decreasing the number of opportunities for misidentified and missed devices across successive program revisions and across multiple compliance schedules. Second, this approach would promote the efficient use of entity and ERO Enterprise resources by eliminating the need to create and audit multiple, successive revisions to entity Protection System Maintenance Programs. Third, this approach would allow NERC additional time to provide additional education and outreach to industry regarding the implementation of this important Reliability Standard, further promoting reliability.

10. The Reliability Standard was developed in an open and fair manner and in accordance with the Commission-approved Reliability Standard development process.¹⁴

The proposed Reliability Standards were developed in accordance with NERC's Commission-approved, ANSI-accredited processes for developing and approving Reliability Standards. **Exhibit I** includes a summary of the Reliability Standards development proceedings, and details the processes followed to develop the proposed Reliability Standards.

¹⁴ Order No. 672 at P 334. Further, in considering whether a proposed Reliability Standard meets the legal standard of review, we will entertain comments about whether the ERO implemented its Commission-approved Reliability Standard development process for the development of the particular proposed Reliability Standard in a proper manner, especially whether the process was open and fair. However, we caution that we will not be sympathetic to arguments by interested parties that choose, for whatever reason, not to participate in the ERO's Reliability Standard development process if it is conducted in good faith in accordance with the procedures approved by FERC.

These processes included, among other things, comment periods, pre-ballot review periods, and balloting periods. Additionally, all meetings of the standard drafting team were properly noticed and open to the public. The initial ballots, non-binding poll,¹⁵ and final ballots achieved a quorum and exceeded the required ballot pool approval levels.

11. NERC must explain any balancing of vital public interests in the development of proposed Reliability Standards.¹⁶

NERC has identified no competing public interests regarding the request for approval of the proposed Reliability Standards. No comments were received indicating the proposed Reliability Standards are in conflict with other vital public interests.

12. Proposed Reliability Standards must consider any other appropriate factors.¹⁷

No other factors relevant to whether the proposed Reliability Standards are just, reasonable, not unduly discriminatory or preferential were identified.

¹⁵ For proposed Reliability Standard PRC-005-6. No non-binding poll was required for proposed Reliability Standard PRC-005-5.

¹⁶ Order No. 672 at P 335. Finally, we understand that at times development of a proposed Reliability Standard may require that a particular reliability goal must be balanced against other vital public interests, such as environmental, social and other goals. We expect the ERO to explain any such balancing in its application for approval of a proposed Reliability Standard.

¹⁷ Order No. 672 at P 323. In considering whether a proposed Reliability Standard is just and reasonable, we will consider the following general factors, as well as other factors that are appropriate for the particular Reliability Standard proposed.

Exhibit D

DGR White Paper

Draft White Paper

Proposed Revisions to the Applicability of NERC Reliability Standards NERC Standards Applicability to Dispersed Generation Resources

**Project 2014-01 Standards Applicability for Dispersed
Generation Resources Standard Drafting Team**

December 11, 2014

Table of Contents

1	EXECUTIVE SUMMARY	3
2	PURPOSE	5
3	BACKGROUND	6
3.1	BES DEFINITION	6
3.2	DISPERSED GENERATION RESOURCES	7
3.3	DRAFTING TEAM EFFORTS	8
4	TECHNICAL DISCUSSION	11
4.1	BAL	11
4.2	COM	11
4.3	EOP	11
4.4	FAC	12
4.5	INT	13
4.6	IRO.....	13
4.7	MOD	14
4.8	NUC	16
4.9	PER	16
4.10	PRC	16
4.11	TOP	22
4.12	TPL.....	27
4.13	VAR.....	28
4.14	CIP	29
	APPENDIX A: LIST OF STANDARDS	32
	APPENDIX B: LIST OF STANDARDS RECOMMENDED FOR FURTHER REVIEW	33

1 Executive Summary

The purpose of this White Paper is to provide background and technical rationale for proposed revisions to the applicability of several North American Electric Reliability Corporation (NERC) Reliability Standards, and in some cases the standard requirements. The goal of the NERC Project 2014-01 Standards Applicability for Dispersed Generation Resources¹ standard drafting team (SDT) is to ensure that the Generator Owners (GOs) and Generator Operators (GOPs) of dispersed power producing resources are appropriately assigned responsibility for requirements that impact the reliability of the Bulk Power System (BPS), as the characteristics of operating dispersed power producing resources can be unique. In light of the revised Bulk Electric System (BES) definition approved by the Federal Energy Regulatory Authority (FERC) in 2014², the intent of this effort is generally to maintain the status quo for applicability of the standards as they have been applied over time with respect to dispersed power producing resources where the status quo does not create a reliability gap.

The SDT reviewed all standards that apply to GOs and GOPs³ and determined how each standard requirement should be appropriately applied to dispersed power producing resources, categorized as follows:

- The existing standard language was appropriate when applied to dispersed power producing resources and does not need to be addressed;
- The existing standard language was appropriate when applied to dispersed power producing resources but additional NERC guidance documentation is needed to clarify how to implement the requirements for dispersed power producing resources; and
- The existing standard language needs to be modified in order to account for the unique characteristics of dispersed power producing resources. This could be accomplished through the Applicability Section of the standard in most cases or, if required, through narrowly-tailored changes to the individual requirements.

From this review, the SDT determined that three (3) Reliability Standards required immediate attention to clarify the applicability of the Reliability Standards to dispersed power producing resources for the benefit of industry stakeholders. These standards are:

- PRC-004 (relevant versions)⁴;
- PRC-005 (relevant versions)⁵; and
- VAR-002 (relevant versions).

The SDT recognized that many other standards⁶ required further review to determine the necessity and the type of clarification or guidance for the applicability to dispersed power producing resources. This

¹ Although the BES definition uses the term “dispersed power producing resources,” the SAR and the SDT also use the term “dispersed generation resources.” For the purposes of this paper, these terms are interchangeable.

² Glossary of Terms Used in NERC Reliability Standards, updated March 12, 2014.

³ See Appendix A.

⁴ Reliability Standard PRC-004 was revised as part of Project 2010-05.1 Protection Systems: Misoperations.

⁵ Reliability Standard PRC-005 was revised as part of Project 2007-17.3 – Protection System Maintenance and Testing – Phase 3.

⁶ See Appendix B.

necessity is based on how each standard requirement, as written, would apply to dispersed power producing resources and the individual generating units at these facilities, considering the now currently-enforced BES definition. The proposed resolutions target the applicability of the standard or target specific individual requirements. There are additional methods to ensure consistent applicability throughout the Regions, including having guidance issued by NERC through Reliability Standard Audit Worksheet (RSAW) language revisions. These tools, among others, have been considered and employed by the SDT throughout the drafting effort.

The White Paper includes: 1) description of the history of standards applicability to dispersed power producing resources; 2) identification of circumstances and practices that are unique to dispersed power producing resources; and 3) determination of the priority to address standards, supported by corresponding technical justification.

It is the intent of the SDT to modify this document over the course of this project to document the SDT's rationale and technical justification for each standard until the work of the SDT is complete. The SDT considers the sections of the White Paper that address the high-priority standards to be in final draft form. The SDT may provide further revisions to the remainder of the White Paper.

2 Purpose

The purpose of this White Paper is to provide background and technical rationale for proposed revisions to the applicability of several Reliability Standards⁷ or requirements that apply to GOs and/or GOPs. The goal of the proposed applicability changes is to provide the GOs and GOPs of dispersed generation resources with clarity regarding their responsibility for requirements that impact the reliability of the BPS, as the characteristics of operating dispersed generation can be unique. The SDT seeks to provide clarity through the method most appropriate for each standard, such as by: (1) revising applicability language in the standard; (2) revising language in the requirements to address changes to applicability; (3) recommending changes to the RSAW associated with the standard; or (4) recommending a reliability guideline or reference document.

This document describes the design, operational characteristics, and unique features of dispersed power producing resources. The recommendations identified in this document consider the Purpose and Time Horizon of the standards and requirements, as well as the avoidance of applying requirements in a manner that has no significant effect on reliability.⁸ This document provides justification of, and proposes revisions to, the applicability of the Reliability Standards and requirements, both existing and in development, and should be considered guidance for future standard development efforts. However, please note that the recommendations provided in this paper are subject to further review and revision.

Note that while this White Paper may provide examples of dispersed power producing resources, the concepts presented are not specific to any one technology. The SDT in general has referenced the BES Reference Document, which also refers to “dispersed power producing resources.” Although the BES definition uses the term “dispersed power producing resources,” the Standard Authorization Request (SAR) and the SDT also use the term “dispersed generation resources.” For the purposes of this paper, these terms are interchangeable.

⁷ Note that “Reliability Standard” is defined in the NERC Glossary as “approved by FERC,” but that the SDT reviewed approved standards, as well as revisions to standards proposed in other projects.

⁸ *North American Electric Reliability Corporation*, 138 FERC ¶ 61,193 at P 81 (2012).

3 Background

Industry stakeholders submitted a SAR to the NERC Standards Committee, requesting that the applicability of Reliability Standards or the requirements of Reliability Standards be revised to ensure that the Reliability Standards are not imposing requirements on dispersed generation resource components that are unnecessary or counterproductive to the reliability of the BPS. The SDT's focus has been to ensure that Reliability Standards are applied to dispersed power producing resources to support an effective defense-in-depth strategy and an adequate level of reliability for the interconnected BPS.

For purposes of this effort, dispersed power producing resources are those individual resources that aggregate to a total capacity greater than 75 MVA gross nameplate rating, and that are connected through a system designed primarily for delivering such capacity to a common point of connection at a voltage of 100 kV or above. This request is related to the approved definition of the BES from Project 2010-17,⁹ which resulted in the inclusion of distinct components of dispersed generation resources.

3.1 BES Definition

The BES definition¹⁰ includes the following inclusion criterion addressing dispersed generation resources:

I4. Dispersed power producing resources that aggregate to a total capacity greater than 75 MVA (gross nameplate rating), and that are connected through a system designed primarily for delivering such capacity to a common point of connection at a voltage of 100 kV or above. Thus, the facilities designated as BES are:

- a) The individual resources, and*
- b) The system designed primarily for delivering capacity from the point where those resources aggregate to greater than 75 MVA to a common point of connection at a voltage of 100 kV or above.*

The *BES Definition Reference Document*¹¹ includes a description of what constitutes dispersed generation resource:

“Dispersed power producing resources are small-scale power generation technologies using a system designed primarily for aggregating capacity providing an alternative to, or an enhancement of, the traditional electric power system. Examples could include but are not limited to: solar, geothermal, energy storage, flywheels, wind, micro-turbines, and fuel cells.”

⁹ http://www.nerc.com/pa/Stand/Pages/Project2010-17_BES.aspx

¹⁰ Glossary of Terms Used in NERC Reliability Standards, updated March 12, 2014.
http://www.nerc.com/pa/Stand/Glossary%20of%20Terms/Glossary_of_Terms.pdf

¹¹ Bulk Electric System Definition Reference Document, Version 2, April 2014.
http://www.nerc.com/pa/Stand/Project%20201017%20Proposed%20Definition%20of%20Bulk%20Electri/bes_phase2_reference_document_20140325_final_clean.pdf.

3.2 Dispersed Power Producing Resources

Dispersed power producing resources are often considered to be variable energy resources such as wind and solar. This description is not explicitly stated in the BES definition; however, NERC and FERC characterize variable generation in this manner regarding the purpose of Inclusion I4 of the definition.¹² Therefore, the SDT is considering the reliability impacts of variable generation that depends on a primary fuel source which varies over time and cannot be stored.¹³ Reliably integrating high levels of variable resources – wind, solar, ocean, and some forms of hydro – into the BPS require significant changes to traditional methods used for system planning and operation.¹⁴ While these resources provide challenges to system operation, these resources are instrumental in meeting government-established renewable portfolio standards and requirements that are based on vital public interests.¹⁵

3.2.1 Design Characteristics

For dispersed power producing resources to be economically viable, it is necessary for the equipment to be geographically dispersed. The generating capacity of individual generating modules can be as small as a few hundred watts to as large as several megawatts. Factors leading to this dispersion requirement include:

- Practical maximum size for wind generators to be transported and installed at a height above ground to optimally utilize the available wind resource;
- Spacing of wind generators geographically to avoid interference between units;
- Solar panel conversion efficiency and solar resource concentration to obtain usable output; and
- Cost-effective transformation and transmission of electricity.

The utilization of small generating units results in a large number of units (e.g., several hundred wind generators or several million solar panels) installed collectively as a single facility that is connected to the Transmission system.

Dispersed power producing resources interconnected to the transmission system typically have a control system at the group level that controls voltage and power output of the Facility. The control system is capable of recognizing the capability of each individual unit or inverter to appropriately distribute the contribution required of the Facility across the available units or inverters. The variable generation control system must also recognize and account for the variation of uncontrollable factors such as wind speed and solar irradiance levels. Thus, for some standards discussed in this paper it is appropriate to apply requirements at the plant level rather than the individual generating unit.

¹² NERC December 13, 2013 filing, page 15 (FERC Docket No. RD14-2); NERC December 13, 2013 filing, page 17 (FERC Docket No. RD14-2); NERC January 25, 2012 filing, page 18 (FERC Docket No. RD14-2), FERC Order Approving Revised Definition, Docket No. RD14-2-000, Issued March 20, 2014.

¹³ “*Electricity Markets and Variable Generation Integration*,” WECC, January 6, 2011.

¹⁴ “*Accommodating High Levels of Variable Generation*,” NERC, April, 2009. http://www.nerc.com/files/ivgtf_report_041609.pdf

¹⁵ See *Rules Concerning Certification of the Electric Reliability Organization; and Procedures for the Establishment, Approval, and Enforcement of Electric Reliability Standards*, Order No. 672, FERC Stats. & Regs. ¶ 31,204, at P 335, *order on reh’g*, Order No. 672-A, FERC Stats. & Regs. ¶ 31,212 (2006).

3.2.2 Operational Characteristics

Dispersed power producing resources often rely on a variable energy source (wind, for example) that is not able to be stored. Because of this, a Facility operator cannot provide a precise forecast of the expected output to a Balancing Authority (BA), Transmission Operator (TOP) or Reliability Coordinator (RC); however, short-term forecasting capability is improving and thus reducing uncertainty.¹⁶ The forecasting and variable operating conditions are well understood by BAs, TOPs, and RCs as evidenced by the successful operation of these generating resources over the years. Dispersed generation resources by their nature result in each individual generating unit potentially experiencing varied power system parameters (e.g. voltage, frequency, etc.) due to varied impedances and other variations in the aggregating facilities design.

Many older dispersed power producing resources are limited in their ability to provide essential reliability services. However, due to technological improvements, newer dispersed generation resources are capable of providing system support for voltage and frequency. For efficiency, the facilities are designed to provide the system requirements at the point of interconnection to the transmission system.

3.2.3 Reliability Impact

A dispersed power producing resource is typically made up of many individual generating units. In most cases, the individual generating units are similar in design and from one manufacturer. The aggregated capability of the Facility may in some cases contribute significantly to the reliability of the BPS. As such, there can be reliability benefits from ensuring the equipment utilized to aggregate the individual units to a common point of connection are operated and maintained as required in certain applicable NERC standards. When evaluated individually, however, the individual generating units often do not provide a significant impact to BPS reliability, as the unavailability or failure of any one individual generating resource may have a negligible impact on the aggregated capability of the Facility. The SDT acknowledges that FERC addressed the question of whether individual resources should be included in the BES definition in Order Nos. 773 and 773-A and concluded that individual wind turbine generators should be included as part of the BES. The SDT is not challenging this conclusion, but rather is addressing the applicability of standards on a requirement-by-requirement basis as necessary to account for the unique characteristics of dispersed generation. Thus, the applicability of requirements to individual generating units may be unnecessary except in cases where a common mode issue exists that could lead to a loss of a significant number of units or the entire Facility in response to a transmission system event.

3.3 Drafting Team Efforts

The SDT approached this project in multiple phases. First, after a thorough discussion of the new definition of the BES, the SDT reviewed each standard, as shown in Appendix A, at a high level to recommend changes that would promote consistent applicability for dispersed power producing resources through the entire set of Reliability Standards. This review provided the type of changes proposed, the justification for the changes, and the priority of the changes. The SDT documented its review in this

¹⁶ “*Electricity Markets and Variable Generation Integration*,” WECC, January 6, 2011. <https://www.wecc.biz/committees/StandingCommittees/JGC/VGS/MWG/ActivityM1/WECC%20Whitepaper%20-%20Electricity%20Markets%20and%20Variable%20Generation%20Integration.pdf>

White Paper, which will continue to be updated throughout the SDT efforts. The second phase, currently in progress, includes revising standards where necessary and supporting the balloting and commenting process.

3.3.1 Scope of Standards Reviewed

Initially, the focus of the standards review was on standards and requirements applicable to GOs and GOPs. However, during discussions, a question was raised to the SDT whether consideration is necessary for other requirements that affect the interaction of a Balancing Authority (BA), Transmission Operator (TOP), or Reliability Coordinator (RC) with individual BES Elements. For example, a requirement that states “an RC shall monitor BES Elements” may unintentionally affect the RC operator due to the revised BES definition. As such, the SDT took a high-level look at all standards adopted by the NERC Board of Trustees (Board) or approved by FERC to ensure this issue was not significant.

All standards that were reviewed are listed in Appendix A along with the status of the standards as of December 11, 2014. The fields in Appendix A include the following:

- List of standards (grouped by approval status);
- Approval status of the standards which include
 - Subject to Enforcement
 - Subject to Future Enforcement
 - Filed and Pending Regulatory Approval
 - Pending Regulatory Filing
 - Designated for Retirement (2 standards – MOD-024-1 and MOD-025-1 – officially listed as Filed and Pending Regulatory Approval but will be superseded by MOD-025-2)
 - In concurrent active development; and
- Indication of change or additional review necessary.

The SDT also reviewed, at a high-level, any approved regional standards. In cases where a change is recommended to a regional standard, the SDT will notify the affected Region. In addition, the SDT is prepared to provide recommendations to other active NERC standard development efforts, where appropriate.

Status	Number of Standards	Number of Standards to be Addressed (Standard, RSAW, Guidance or Further Review)
NERC Standards	166	27
Subject to Enforcement	101	12
Subject to Future Enforcement	20	5
Pending Regulatory Approval	28	4
Pending Regulatory Filing	7	0
Designated for Retirement	2	0
Proposed for Remand	8	6
Region-specific Standards (*Out of Scope)	17	4
Subject to Enforcement	15	3
Subject to Future Enforcement	2	1
Pending Regulatory Approval	0	0
Grand Total	183	31

3.3.2 Reliability Objectives

The SDT used the following Reliability Objectives to review the standards:

- Interconnected bulk power systems shall be planned and operated in a coordinated manner to perform reliably under normal and abnormal conditions as defined in the NERC Standards;
- The frequency and voltage of interconnected bulk power systems shall be controlled within defined limits through the balancing of real and reactive power supply and demand;
- Information necessary for the planning and operation of interconnected bulk power systems shall be made available to those entities responsible for planning and operating the systems reliably;
- Plans for Emergency operation and system restoration of interconnected bulk power systems shall be developed, coordinated, maintained, and implemented;
- Facilities for communication, monitoring, and control shall be provided, used, and maintained for the reliability of interconnected bulk power systems;
- Personnel responsible for planning and operating interconnected bulk power systems shall be trained, qualified, and have the responsibility and authority to implement actions;
- The reliability of the interconnected bulk power systems shall be assessed, monitored, and maintained on a wide-area basis; and
- Bulk power systems shall be protected from malicious physical or cyber attacks.

3.3.3 Prioritization Methodology

The SDT established a prioritization to review and modify applicability changes recommended to NERC standards and requirements. The SDT evaluated each requirement to identify the appropriate applicability to support reliability of the BPS. In general, any standard or requirement the SDT determined required modification was assigned a high, medium, or low priority. The standards and requirements priorities were established as follows:

- High priority was assigned so that standard or requirement changes would be made quickly enough to avoid an entity having to expend inordinate resources prematurely to comply with a standard or requirement that, after appropriate modification, would not be applicable to that entity;
- Medium priority was assigned if significant effort and resources with no appreciable reliability benefit would be required by an entity to be compliant; and
- Low priority was assigned to other changes that may need to be made to further ensure requirements add to reliability, but are not perceived as a significant compliance burden.

The prioritization of each recommendation is identified in Appendix B.

- List of standards (grouped by priority);
- Approval status of the standards (same designations as used in Appendix A);
- Recommendation of changing the Applicability Section of the standard or by changing the applicability for specific requirements; and
- Recommendation of which applicability options should apply.

4 Technical Discussion

This section provides a review of each group of standards, focusing on the impact of the BES definition on reliability and compliance efforts. This discussion proposes a resolution for each standard, whether it is a change in the Applicability Section or in a specific requirement, clarification in a guidance document, or no action needed.

4.1 BAL

The group of BAL standards focuses primarily on ensuring the Balancing Authority (BA) has the awareness, ability, and authority to maintain the frequency and operating conditions within its BA Area. Only two standards in this group affect GO and/or GOP, and no BAL standard reviewed affected the interaction of a host BA, TOP, or RC with individual BES Elements.

4.1.1 BAL-005 — Automatic Generation Control

The purpose of this standard, as it applies to GOPs, is to ensure that all facilities electrically synchronized to the Interconnection are included within the metered boundary of a BA Area so that balancing of resources and demand can be achieved. Ensuring the Facility as a whole is within a BA Area ensures the individual units are included. *Therefore, the applicability of the BAL-005 standard does not need to be changed for dispersed power producing resources.*

4.1.2 BAL-001-TRE-1 — Primary Frequency Response in the ERCOT Region

The purpose of BAL-001-TRE-1 standard is to maintain Interconnection steady-state frequency within defined limits. This standard should be modified to clarify the applicability for dispersed power producing resources to the total plant level to ensure coordinated performance. However, this is a regional standard and not part of the SDT scope. *The SDT will communicate this recommendation to the relevant Region.*

4.2 COM

The COM standards focus on communication between the RC, BAs, TOPs, and GOPs. The only requirements in any of the current or future enforceable standards that apply to the GOP are clearly intended to apply to the individual GOP registered functional entity (i.e., requires communication between GOPs, TOPs, BAs, and RCs), not the constituent Elements it operates. Consequently, there is no need to differentiate the GOPs obligation for dispersed power producing resources from any other resources. *Therefore, the applicability of the COM-001-2, COM-002-2a, and COM-002-4 standards that were reviewed do not need to be changed for dispersed power producing resources.*

4.3 EOP

The EOP standards focus on emergency operations and reporting. The standards that apply to GO and/or GOP entities are EOP-004 and EOP-005. No EOP standard reviewed affects the interaction of a host BA, TOP, or RC with individual BES Elements.

4.3.1 EOP-004 — Event Reporting

The purpose of this standard is to improve the reliability of the BES by requiring the reporting of events by Responsible Entities. The requirements of this standard that apply to the GO and GOP appear to apply

to the individual GO and GOP registered functional entity, not the constituent elements. *The SDT has considered whether there is a need to differentiate dispersed power producing resources from any other GO and/or GOP resource and determined that no changes are required to the standard.*

4.3.2 EOP-005 — System Restoration from Blackstart Resources

EOP-005 ensures plans are in place to restore the grid from a de-energized state. The requirements that apply to a GOP are primarily for individual generation facilities designated as Blackstart Resources, with one requirement to participate in restoration exercises or simulations as requested by the RC. The inclusion of Blackstart Resources is already identified in the BES definition through Inclusion I3. The expectation is that all registered GOPs will participate in restoration exercises as requested by its RC. *Therefore, the applicability of EOP-005 does not need to be changed for dispersed power producing resources.*

4.4 FAC

The FAC standards focus on establishing ratings and limits of the Facility and interconnection requirements to the BES. Several standards apply to GOs and/or GOPs. No FAC standard reviewed affects the interaction of a host BA, TOP, or RC with individual BES Elements.

4.4.1 FAC-001 — Facility Connection Requirements

Requirements R2 and R3 of this standard apply to any GO that has an external party applying for interconnection to the GO's existing Facility in order to connect to the transmission system. This scenario is uncommon and there is no precedent for applicability of this standard to dispersed *power producing* resources known to the SDT. Current practice primarily includes the GO stating that they will comply with the standard if this scenario is ever realized. This standard allows the GO to specify the conditions that must be met for the interconnection of the third-party, thus providing inherent flexibility to tailor the requirements specifically for the unique needs of the Facility. *Therefore, the applicability of FAC-001 does not need to be changed for dispersed power producing resources.*

4.4.2 FAC-002 — Coordination of Plans for New Facilities

The purpose of FAC-002 is to ensure coordinated assessments of new facilities. The requirement applicable to GOs requires coordination and cooperation on assessments to demonstrate the impact of new facilities on the interconnected system and to demonstrate compliance with NERC standards and other applicable requirements. The methods used to demonstrate compliance are independent of the type of generation and are typically completed at the point of interconnection. *Therefore, the applicability of FAC-002 does not need to be changed for dispersed power producing resources.*

4.4.3 FAC-003 — Transmission Vegetation Management

The purpose of this standard is to ensure programs and efforts are in place to prevent vegetation-related outages. This standard applies equally to dispersed generation facilities and traditional Facilities in both applicability and current practices, as it pertains to overhead transmission lines of applicable generation interconnection Facilities. *Therefore, the applicability of FAC-003 does not need to be changed for dispersed power producing resources.*

4.4.4 FAC-008 — Facility Ratings

FAC-008 ensures Facility ratings used in the planning and operation of the BES are established and communicated. The Facility ratings requirement has historically been applicable to dispersed power producing resources and current practices associated with compliance are similar to traditional generation facilities. There is inherent flexibility in the standard requirements for the GO to determine the methodology utilized in determining the Facility ratings.

To identify the Facility rating of a dispersed power producing resource the analysis of the entire suite of Facility components is necessary to adequately identify the minimum and maximum Facility Rating and System Operating Limits, and thus there would be no differentiation between the compliance obligations between dispersed power producing resources and traditional generation. *The SDT believes the industry and Regions would benefit from additional guidance on FAC-008 in the form of changes to add a technical guidance section to the standard, or other guidance.*

4.5 INT

The INT standards provide BAs the authority to monitor power interchange between BA Areas. No INT standard is applicable to the GO or GOP, or affects the interaction of a host BA, TOP, or RC with individual BES Elements. *Therefore, the applicability of the INT standards do not need to be changed for dispersed power producing resources.*

4.6 IRO

The IRO standards provide RCs their authority. There are three IRO Standards that apply directly to GO and/or GOP entities. There are three standards that apply to the interaction of the RC with individual BES Elements. No other IRO standard reviewed affected the interaction of a host BA, TOP, or RC with GOs and/or GOPs.

4.6.1 IRO-001 — Reliability Coordination — Responsibilities and Authorities¹⁷

The purpose of these standards and their requirements as applicable to a GOP is to ensure RC directives are complied with so long as they do not violate safety, equipment, or regulatory or statutory requirements, or cannot be physically implemented. If a GOP is unable to follow a RC directive they are to inform the RC immediately of such.

Directives from RCs have been traditionally applied to the dispersed power producing resource at the aggregate Facility level when they are related to either active power or voltage, such as an output reduction or the provision of voltage support. When such directives are not specific to any one Element within the Facility, it is up to the GOP to determine the appropriate method to achieve the desired result of the directive consistent with other applicable NERC Reliability Standards. When an RC directive specifies a particular Element or Elements at the GOP's Facility, it is the expectation and requirement that the GOP will act as directed, so long as doing so does not violate safety, equipment, or regulatory or statutory requirements or cannot be physically implemented. For example, a directive could specify

¹⁷ Note that IRO-001-3, which is adopted by the Board, was included in the proposed remand by FERC and is subject to revision as part of Project 2014-3 – Revisions to TOP and IRO Standards.

operation of a particular circuit breaker at a GOP Facility. *For these reasons, the applicability of IRO-001 does not need to be changed for dispersed power producing resources.*

4.6.2 IRO-005 — Reliability Coordination — Current Day Operations¹⁸

The purpose of this standard and its requirements as it relates to GOPs is to ensure when there is a difference in derived limits the BES is operated to the most limiting parameter. A difference in derived limits can occur on any Element and therefore any limitation of the applicability of this standard may create a reliability gap. There is no need to differentiate applicability to dispersed generation resources from any other GOP resources. *Therefore, the applicability of IRO-005 does not need to be changed for dispersed power producing resources.*

4.6.3 IRO-010 — Reliability Coordinator Data Specification and Collection

The purpose of this standard and its requirement(s) as it relates to GOs and GOPs is to ensure data and information specified by the RC is provided. As each RC area is different in nature, up to and including the tools used to ensure the reliability of the BPS, a ‘one size fits all’ approach is not appropriate. This Reliability Standard allows for the RC to specify the data and information required from the GO and/or the GOP, based on what is required to support the reliability of the BPS. *Therefore, the applicability of IRO-010 does not need to be changed for dispersed power producing resources.*

4.7 MOD

The MOD group of standards ensures consistent modeling data requirements and reporting procedures. The MOD standards provide a path for Transmission Planners (TPs) and Planning Coordinators (PCs) to reach out to entities for specific modeling information, if required. The SDT believes the existing and proposed modeling standards are sufficient for modeling dispersed power producing resources. However, due to the unique nature of dispersed power producing resources and an effort to bring consistency to the models, *the SDT believes additional guidance on the MOD standards would be beneficial and will communicate its determination to the NERC Planning Committee.*

4.7.1 MOD-010 — Steady-State Data for Transmission System Modeling and Simulation

This standard is anticipated to be retired in the near future. There is no need to differentiate dispersed generation resources from any other GOP resources as discussed in 5.7.8 regarding MOD-032. *Therefore, the applicability of MOD-010 does not need to be changed for dispersed generation resources.*

4.7.2 MOD-012 — Dynamics Data for Transmission System Modeling and Simulation

This standard is anticipated to be retired in the near future. There is no need to differentiate dispersed generation resources from any other GOP resources as discussed in 5.7.8 regarding MOD-032. *Therefore, the applicability of MOD-012 does not need to be changed for dispersed generation resources.*

¹⁸ Note that applicability to GOPs has been removed in IRO-005-4, which is adopted by the Board. However, this standard was included in the proposed remand by FERC and is subject to revision as part of Project 2014-3 – Revisions to TOP and IRO Standards.

4.7.3 MOD-024-1 — Verification of Generator Gross and Net Real Power Capability

This standard was established to ensure accurate information on generator gross and net Real Power capability is available for steady-state models used to assess BES reliability. This standard will be superseded by MOD-025-2.¹⁹ *Therefore, the applicability of MOD-024-1 does not need to be changed for dispersed generation resources.*

4.7.4 MOD-025-1 — Verification of Generator Gross and Net Reactive Power Capability

This standard was established to ensure accurate information on generator gross and net Reactive Power capability is available for steady-state models used to assess BES reliability. This standard will be superseded by MOD-025-2. *Therefore, the applicability of MOD-025-1 does not need to be changed for dispersed generation resources.*

4.7.5 MOD-025-2 — Verification and Data Reporting of Generator Real and Reactive Power Capability and Synchronous Condenser Reactive Power Capability

The purpose of MOD-025-2 is to ensure that accurate information on generator gross and net Real and Reactive Power capability is available for planning models used to assess BES reliability. This standard is appropriate for and includes specific provisions for dispersed generation resources to ensure changes in capabilities are reported. *Therefore, the SDT is further evaluating whether to revise the applicability of the standard to align the language with the revised BES definition.*

4.7.6 MOD-026 — Verification of Models and Data for Generator Excitation Control System or Plant Volt/VAR Control Functions

This standard provides for verification of models and data for voltage control functions. This standard is appropriate for dispersed generation resources. *Originally, the DGR SDT considered clarifying the applicability of the Facilities section, however, upon further review, the DGR SDT recommends no change.*

4.7.7 MOD-027 — Verification of Models and Data for Turbine/Governor and Load Control or Active Power/Frequency Control Functions

This standard was established to verify that the turbine/governor and frequency control model accurately represent generator unit Real Power response to system frequency variations. This standard is appropriate for dispersed generation resources. *Originally, the DGR SDT considered clarifying the applicability of the Facilities section, however, upon further review, the DGR SDT recommends no change.*

4.7.8 MOD-032 — Data for Power System Modeling and Analysis

The MOD-032 standard was established to ensure consistent modeling data requirements and reporting procedures for the planning horizon cases. The nature of dispersed generation resources is a challenge in modeling the steady-state and dynamic electrical properties of the individual components (e.g. individual units, collector system, interconnection components, etc.).

¹⁹ MOD-024-1 and MOD-025-1 are Board Adopted but not subject to enforcement. They are commonly followed as good utility practice.

Models for dispersed power producing resources are typically proprietary and unique for each Facility. Generic models exist for dynamic analysis that may provide sufficient accuracy in lieu of a Facility-specific model. Some sections of the MOD-032 Attachment 1 pertain to modeling individual units, which may not be feasible. Guidance should be provided to show how to best model dispersed power producing resources. Such guidance should require modeling requirements for each type of dispersed power producing resource within a Facility and aggregate model for each reasonable aggregation point. *The applicability of MOD-032 does not need to be changed for dispersed power producing resources.*

4.8 NUC

The requirements in standard NUC-001 — *Nuclear Plant Interface Coordination* individually define the applicability to Registered Entities, not to the Elements the entities own or operate. While it is unlikely any Elements that are part of a dispersed power producing resource would be subject to an agreement required by this standard, limiting the applicability of this standard could create a reliability gap and thus, there is no need to differentiate applicability to dispersed generation resources. *Therefore, the applicability of the NUC standard does not need to be changed for dispersed power producing resources.*

4.9 PER

The PER standards focus on operator personnel training. The only requirements in any of the current or future enforceable standards that apply to the GOP is requirement R6 in PER-005-2 – *Operations Personnel Training*, and it is clearly intended to apply to the individual GOP registered functional entity that controls a fleet of generating facilities, not the constituent Elements it operates. As such, there is no need to differentiate dispersed power producing resources from any other GOP resources. *Therefore, the applicability of the PER standards do not need to be changed for dispersed power producing resources.*

4.10 PRC

The PRC standards establish guidance to ensure appropriate protection is established to protect the BES.

4.10.1 PRC-001-1.1 — System Protection Coordination

Requirement R1 requires GOPs to be familiar with the purpose and limitations of Protection System schemes applied in their area. The recently approved changes to the BES definition extend the applicability of this requirement. Often this familiarity is provided to GOP personnel through training on the basic concepts of relay protection and how it is utilized. The basic relaying concepts utilized in protection on the aggregating equipment at a dispersed generation site typically will not vary significantly from the concepts used in Protection Systems on individual generating units.

Requirement R2 requires that GOPs report protective relay or equipment failures that reduce system reliability. Protective System failures occurring within a single individual generating unit at a dispersed power producing resource will not have any impact on overall system reliability and thus it should not be necessary for GOPs to report these failures to their TOP and host BA. Only failures of Protection Systems on aggregating equipment have the potential to impact BPS reliability and may require notification. When interpreted as stated above, no related changes should be required to the existing PRC-001-1 standard, as the BES definition changes do not have an impact on these requirements.

Requirement R3 requires GOPs to coordinate new protective systems. Coordinating new and changes to existing protective relay schemes should be applied to aggregating equipment protection only if a lack of coordination could cause unintended operation or non-operation of an interconnected entity's protection, thus potentially having an adverse impact to the BPS. Existing industry practice is to share/coordinate the protective relay settings on the point of interconnect (e.g. generator leads, radial generator tie-line, etc.) and potentially the main step-up transformer, but not operating (collection) buses, collection feeder, or individual generator protection schemes, as these Protection Systems do not directly coordinate with an interconnected utility's own Protection Systems. Relay protection functions such as under and overfrequency and under and overvoltage changes are independent of the interconnected utility's protective relay settings and the setting criteria are defined in PRC-024.

Requirement R5 requires GOPs to coordinate changes in generation, transmission, load, or operating conditions that could require changes in the Protection Systems of others. A GOP of a dispersed generation resource should be required to notify its TOP of changes to generation, transmission, load, or operating conditions on an aggregate Facility level.

Project 2007-06 – System Protection Coordination and Project 2014-03 – Revisions to TOP and IRO Standards are presently revising various aspects of this standard or addressing certain requirements in other standards.

For these reasons, the DGR SDT coordinated with the other SDTs currently reviewing this standard and recommended revisions to Requirement R3.1 to indicate that coordination by a GOP with their TOP and host BA of new or changes to protection systems on individual generating units of dispersed power producing resources is not required.

4.10.2 PRC-001-2 — System Protection Coordination

The concerns addressed with PRC-001-1.1b are removed in PRC-001-2, which is adopted by the Board. However, this standard was included in the proposed remand by FERC and is subject to revision as part of Project 2014-03 – Revisions to TOP and IRO Standards. This Standard version is not in effect and was withdrawn as the proposed versions of the TOP and IRO Reliability Standards included in Project 2014-3 effectively replace PRC-001-2 and other TOP standards. *For this reason, no changes are required.*

4.10.3 PRC-002-NPCC-01— Disturbance Monitoring PRC-018-1 — Disturbance Monitoring Equipment Installation and Data Reporting

Requirements related to installation of Fault/Disturbance monitoring and/or sequence of events (SOE) recording capabilities on generating units and substation equipment which meet regional specific criteria may require installation of these capabilities on the aggregating equipment at a dispersed power producing resource Facility, and also requires maintenance and periodic reporting requirements to their RRO. However, these requirements have been previously applicable to the aggregating equipment at these dispersed power producing resources, and these capabilities are not required to be installed on the individual generating units. The BES definition changes have no direct impact on applicability of these

standards to dispersed power producing resources. *Therefore, the applicability of these standards do not need to be changed for dispersed power producing resources.*²⁰

4.10.4 PRC-004-2.1a – Analysis and Mitigation of Transmission and Generation Protection System Misoperations

PRC-004-3 — Protection System Misoperation Identification and Correction

Misoperation reporting per PRC-004 is currently a requirement applied on the aggregating equipment at applicable dispersed power producing resource sites meeting BPS criteria. The continuation of this analysis and reporting on the aggregating equipment by dispersed generation resource owners can provide value to BPS reliability and should remain in place. However, based on the experience of the SDT, there is minimal impact to BPS reliability for analyzing, reporting and developing Corrective Action Plans for each individual generating unit that trips at a dispersed power producing resource site, as the tripping of one or a small number of these units has no material impact to the BPS reliability.

Additionally, reporting of Misoperations on each individual generating unit may result in substantial and unnecessary burdens on both the dispersed generation resource owner and the Regional Entities that review and track the resulting reports and Corrective Action Plan implementations. The SDT recognizes that many turbine technologies do not have the design capability of providing sufficient data for an entity to evaluate whether a Misoperation has occurred. Furthermore, dispersed power producing resources by their nature result in each individual generating unit potentially experiencing varied power system parameters (e.g., voltage, frequency, etc.) due to varied impedances and other variations in the aggregating facilities design. This limits the ability to determine whether an individual unit correctly responded to a system disturbance.

However, the SDT maintains that Misoperations occurring on the Protection Systems of individual generation resources identified under Inclusion I4 of the BES definition do not have a material impact on BES reliability when considered individually; however, the aggregate capability of these resources may impact BES reliability if a large number of the individual generation resources (aggregate nameplate rating of greater than 75 MVA) incorrectly operated or failed to operate as designed during a system event. As such, if a trip aggregating to greater than 75 MVA occurs in response to a system disturbance, the SDT proposed requiring analysis and reporting of Misoperations of individual generating units for which the root cause of the Protection System operation(s) affected an aggregate rating of greater than 75 MVA of BES Facilities. Note that the SDT selected the 75 MVA nameplate threshold for consistency and to prevent confusion.

The SDT was also concerned with the applicability of events where one or more individual units tripped and the root cause of the operations was identified as a setting error. In this case, the requirements of PRC-004 would be applicable for any individual units where identical settings were applied on the Protection Systems of like individual generation resources identified under Inclusion I4 of the BES definition.

The SDT concluded that it is not necessary under PRC-004 to analyze each individual Protection System Misoperation affecting individual generating units of a dispersed power producing resource. *The SDT*

²⁰ See NPCC CGS-005.

recommended changes to the applicability of this standard to require misoperation analysis on individual generating units at a dispersed power producing resource site, only for events affecting greater than 75MVA aggregate nameplate; the SDT determined that this will ensure that common mode failure scenarios and their potential impact on BPS reliability are appropriately addressed. The SDT's recommended changes passed industry ballot on November 6, 2014, and were approved by the Board on November 13, 2014, and are currently pending regulatory approval.

4.10.5 PRC-004-WECC-1 — Protection System and Remedial Action Scheme Misoperation

Dispersed power producing resource sites typically would not be associated with a WECC Major Transfer Path or Remedial Action Scheme (RAS), and thus would not be affected by PRC-004-WECC-1. If a site were to be involved with one of these paths or schemes, it is likely that associated protection or RAS equipment would be located on the aggregating equipment rather than the individual generating units. As such, the BES definition changes may have an impact on applicability of this standard to dispersed power producing resources. This standard should be modified to clarify the applicability for dispersed generation resources; however, this is a regional standard and not part of the SDT's scope. *Therefore, the SDT recommends that the relevant Region evaluate the standard for modification.*

4.10.6 PRC-005-1.1b — Transmission and Generation Protection System Maintenance and Testing

The SDT recognizes that PRC-005-1.1b will be phased out beginning in early 2015. Therefore, the SDT recommends only guidance on PRC-005-1.1b rather than suggesting language changes to the standard. *Therefore, the SDT does not recommend revising the applicability of this standard for dispersed generation resources, rather, the SDT provided recommendations for revisions to the applicable RSAW to NERC staff, which NERC has implemented after consultation with the Regions.*

4.10.7 PRC-005-2 — Protection System Maintenance PRC-005-3 — Protection System and Automatic Reclosing Maintenance PRC-005-4 — Protection System, Automatic Reclosing, and Sudden Pressure Relaying Maintenance

The aggregated capability of the individual generating units may in some cases contribute to the reliability of the BPS; as such, there can be reliability benefit from ensuring certain BES equipment utilized to aggregate the individual units to a common point of connection are operated and maintained as required in PRC-005. When evaluated individually, however, the generating units themselves do not have the same impact on BPS reliability as the system used to aggregate the units. The unavailability or failure of any one individual generating unit would have a negligible impact on the aggregated capability of the Facility; this would be irrespective to whether the dispersed generation resource became unavailable due to occurrence of a legitimate fault condition or due to a failure of a control system, protective element, dc supply, etc.

The protection typically utilized in these generating units includes elements which would automatically remove the individual unit from service for certain internal or external conditions, including an internal fault in the unit. These units typically are designed to provide generation output at low voltage levels, (i.e., less than 1000 V). Should these protection elements fail to remove the generating unit for this scenario, the impacts would be limited to the loss the individual generating unit and potentially the next

device upstream in the collection system of the dispersed power producing resource. However, this would still only result in the loss of a portion of the aggregated capability of the Facility, which would be equally likely to occur due to a scenario in which a fault occurs on the collection system.

Internal faults on the low voltage system of these generating units would not be discernible on the interconnected transmission systems, as this is similar to a fault occurring on a typical utility distribution system fed from a substation designed to serve customer load. It is important to note that the collection system equipment (e.g., breakers, relays, etc.) used to aggregate the individual units may be relied upon to clear the fault condition in both of the above scenarios, which further justifies ensuring portions of the BES collection equipment is maintained appropriately.

**4.10.8 For this reason, activities such as Protection System maintenance on each individual generating unit at a dispersed generation Facility would not provide any additional reliability benefits to the BPS, but Protection System maintenance on facilities where generation aggregates to 75 MVA or more would. The SDT proposes that the scope of PRC-005 be limited to include only the protection systems that operate at a point of aggregation above 75 MVA nameplate rating. If the aggregation point occurs at a component in the collection system, then the protection systems associated with this component would be in scope. *The SDT has recommended changes to the Applicability Section (Facilities) of PRC-005-2, -3, and -4 to indicate that maintenance activities should only apply on the aggregating equipment at or above the point where the aggregation exceeds 75 MVA. The SDT's recommended applicability changes to PRC-005-2 and PRC-005-3 were approved by the Board on November 13, 2014. The SDT's recommended applicability changes to PRC-005-4 were posted for an initial ballot period that ends on January 22, 2014.* PRC-006-NPCC-1 — Automatic Underfrequency Load Shedding
PRC-006-SERC -1 — Automatic Underfrequency Load Shedding Requirements**

The regional specific PRC-006 standards deviate from the PRC-006-1 standard in that they have specific requirements for GOs. In particular, the NPCC version requires that GOs set their underfrequency tripping to meet certain criteria to ensure reliability of the BPS. Typically a dispersed generation resource site may have underfrequency protection on both the aggregating equipment (i.e., collection buses or feeders) as well as the individual generating units. Were this standard only to apply to aggregating equipment, the net impact to the BPS should a system disturbance occur may still result in a loss of significant generating capacity should each of the individual generating units trip for the event. Therefore it may be appropriate to include the individual generating units at a dispersed generation resource site as subject to this standard. The standard could be interpreted this way as written, but further clarification in the standard language may be considered. While this standard may need to be modified to clarify the applicability for dispersed generation resources, this is a regional standard and not part of the SDT's scope. *Therefore, the SDT recommends that the relevant Region evaluate the standard for modification.*

The SERC version of PRC-006 requires GOs to provide, upon request, certain under and overfrequency related set points and other related capabilities of the site relative to system disturbances. It may be appropriate to include the capabilities of the individual generating units at a dispersed generation resource site when providing this information; however, it may be sufficient to provide only the capabilities of a

single sample unit within a site as these units are typically set identically. This would be in addition to any related capabilities or limitations of the aggregating equipment as well. This may be accomplished by providing clarifications in the requirements sections. While this standard may need to be modified to clarify the applicability for dispersed power producing resources, this is a regional standard and not part of the SDT's scope. *Therefore, the SDT recommends that the relevant Region evaluate the standard for modification.*

4.10.9 PRC-015 — Special Protection System Data and Documentation
PRC-016 — Special Protection System Misoperations
PRC-017 — Special Protection System Maintenance and Testing

Relatively few dispersed power producing resources own or operate Special Protection Systems (SPSs); however, they do exist and therefore need to be evaluated for applicability based on the revised BES definition. The vast majority of these SPSs involve the aggregating equipment (transformers, collection breakers, etc.) and not the individual generating units. The SPSs are installed to protect the reliability of the BPS, and as such the aggregated response of the site (e.g., reduction in output, complete disconnection from the BES, etc.) is critical, not the response of individual generating units. *Therefore, the applicability of these standards does not need to be changed for dispersed power producing resources.*

4.10.10 PRC-019-1 — Coordination of Generating Unit or Plant Capabilities, Voltage Regulating Controls, and Protection

Dispersed power producing resources typically utilize a site level voltage control scheme that directs the individual generating units to adjust their output to meet the voltage requirements at an aggregate Facility level. In these cases the individual generating units will simply no longer respond once they are “maxed out” in providing voltage or reactive changes, but also need to be properly coordinated with protection trip settings on the aggregating equipment to mitigate risk of tripping in this scenario. For those facilities that solely regulate voltage at the individual unit, these facilities also need to consider the Protection Systems at the individual units and their compatibility with the reactive and voltage limitations of the units. The applicability in PRC-019-1 (section 4.2.3) includes a “Generating plant/Facility consisting of one or more units that are connected to the Bulk Electric System at a common bus with total generation greater than 75 MVA (gross aggregate nameplate rating).” *Therefore, the DGR SDT revised the Facilities section of the standard to clarify that facilities which solely regulate voltage at the individual generating unit are subject to this standard's requirements. The SDT's recommended applicability changes to PRC-019-1 were posted for an initial comment and ballot period scheduled to close December 22, 2014.*

4.10.11 PRC-023— Transmission Relay Loadability

Dispersed power producing resources in some cases contain facilities and Protection Systems that meet the criteria described in the Applicability Section (e.g., load responsive phase Protection System on transmission lines operated at 200 kV or above); however, in the majority of cases these lines are radially connected to the remainder of the BES and are excluded from the standard requirements of PRC-023-3. While certain entities with dispersed power producing resources are required to meet the requirements of PRC-023 on components of their aggregating equipment (e.g., main step-up transformers, interconnecting transmission lines) the standard is not applicable to the individual generating units, as the individual generating units are addressed in PRC-025. The BES definition changes have no direct impact on the

applicability of this standard to dispersed power producing resources. *Therefore, the applicability of this standard does not need to be changed for dispersed power producing resources.*

4.10.12 PRC-024— Generator Frequency and Voltage Protective Relay Settings

If the individual generating units at a dispersed power producing resource were excluded from this requirement, it is possible large portions or perhaps the entire output of a dispersed power producing resource site may be lost during certain system disturbances, negatively impacting BES reliability. The SDT has determined it is appropriate to require that Protection System settings applied on both the individual generating units and aggregating equipment (including any Protection Systems applied on non-BES portions of the aggregating equipment), are set within the “no-trip zone” referenced in the requirements to maintain reliability of the BES. However, for the purpose of compliance evidence, the SDT believes it should be sufficient for an entity to provide evidence for a single sample generating unit within a site rather than providing documentation for each individual unit, providing the entity used that methodology to set its protection systems for all the units, rather than providing documentation for each individual unit. This would be in addition to any Protection System settings evidence for the aggregating equipment. *The SDT therefore recommended changes to the standard requirements to ensure these requirements are applied to the individual power producing resources as well as all equipment, potentially including non-BES equipment, from the individual power producing resource up to the point of interconnection and communicated compliance evidence requirement considerations to NERC staff for RSAW development. The SDT’s recommended applicability changes to PRC-024 were posted for an initial comment and ballot period scheduled to close December 22, 2014.*

4.10.13 PRC-025— Generator Relay Loadability

The Protection System utilized on individual generating units at a dispersed power producing Facility may include load-responsive protective relays and thus would be subject to the settings requirements listed in this standard. Were this standard only to apply to aggregating equipment, the net impact to the BPS should a system disturbance occur, may be a loss of significant generating capacity should each of the individual generating units trip for the event. The SDT has determined it is appropriate to require that Protection System settings applied on both the individual generating units at a dispersed power producing resource site as applicable to this standard. However, for the purpose of compliance evidence, the SDT believes it should be sufficient for an entity to provide evidence for a single sample generating unit within a site rather than providing documentation for each individual unit, providing the entity used that methodology to set its protection systems for all the units, rather than providing documentation for each individual unit. This would be in addition to any Protection System settings evidence for the aggregating equipment. As such the SDT recommends the RSAW be modified as stated above. *The SDT recommended no changes to the standard; however, the DGR SDT communicated compliance evidence requirement considerations to NERC staff for RSAW development.*

4.11 TOP

The TOP standards provide TOPs their authority. There are four TOP standards that apply directly to GO and GOP entities. The TOP standards as they relate to GOs/GOPs ensure RCs and TOPs can issue directives to the GOP, and the GOP follows such directives. They also ensure GOPs render all available

emergency assistance as requested. Finally, they require GO/GOPs to coordinate their operations and outages and provide data and information to the BA and TOP. No TOP standard refers to the interaction of a host BA, TOP, or RC with individual BES Elements.

4.11.1 TOP-001-1a — Reliability Responsibilities and Authorities

This standard as it applies to GOPs is reviewed at the requirement level, with only one change recommended.

4.11.1.1 Requirement R3

The purpose of requirement R3 as it relates to GOPs is to ensure the RC and TOP reliability directives are complied with so long as they do not violate safety, equipment, or regulatory or statutory requirements. If a GOP is unable to follow a RC or TOP reliability directive they are to inform the RC or TOP immediately of such. The requirement is applicable to the registered functional entity, not the constituent Elements it operates. *Therefore, there is no need to differentiate applicability to dispersed power producing resources from any other GOP resources, and no change to this requirement is needed.*

4.11.1.2 Requirement R6

The purpose of requirement R6 as it relates to GOPs is to ensure all available emergency assistance to others as requested, unless such actions would violate safety, equipment, or regulatory or statutory requirements. The requirement is applicable to the registered functional entity, not the constituent Elements it operates. *Therefore, there is no need to differentiate applicability to dispersed power producing resources from any other GOP resources, and no change to this requirement is needed.*

4.11.1.3 Requirement R7

The purpose of requirement R7 as it relates to GOPs is to ensure BES facilities are not removed from service without proper notification and coordination with the TOP and, when time does not permit such prior notification and coordination, notification and coordination shall occur as soon as reasonably possible. This is required to avoid burdens on neighboring systems. It should be noted that the purpose of this standard is to keep the TOP informed of all generating Facility capabilities in case of an emergency. It is assumed that required notification and coordination from the GOP to the TOP would be done in real-time and through verbal communication media. The concern here is how to apply this to a dispersed power producing resource Facility. The SDT recommends that the GOP report at the aggregate Facility level to the TOP any generator outage above 20 MVA for dispersed power producing resource facilities. The justification is based on the following:

- This is consistent with Inclusion I2 of the revised BES definition, which addresses only generating units greater than 20 MVA.
- TOP-002-2.1b Requirement R14 requires real-time notification of changes in Real Power capabilities, planned and unplanned. Setting the threshold at 20 MVA would address routine maintenance on a small portion of the Facility (e.g., 2% of the generators are out of service on any given day) and individual generating units going into a failure. Otherwise, coordinating each individual generating unit outage would burden the TOP without providing an increase in reliability to the interconnected BPS.

Dispersed power producing resource outages should be reported as X MW out of Y MW are available. *Therefore, the SDT recommends that a modification to the applicability of this requirement is necessary for dispersed power producing resources for generator outages greater than 20 MVA.*

4.11.2 TOP-001-3— Transmission Operations²¹

The purpose of this standard as it relates to GOPs is to ensure TOP directives are complied with so long as they do not violate safety, equipment, or regulatory or statutory requirements. If a GOP is unable to follow a TOP directive they are to inform the TOP immediately of such. It directs the TOP to issue directives and as such the TOP may provide special requirements for dispersed power producing resources for its unique capabilities. *The SDT recommends that Project 2014-3 provide direction for a dispersed power producing resource to be only reported at the aggregate facility level. If TOP-001-1a R7 is reintroduced, then the recommendation provided above should be included in their efforts.*

4.11.3 TOP-002-2.1b — Normal Operations Planning²²

This TOP standard has five requirements applied to GOPs. Several modifications are recommended below, and the SDT recommends that the most effective and efficient way to accomplish this is through modification of the Applicability Section of this standard.

4.11.3.1 Requirement R3

The purpose of requirement R3 as it relates to GOPs is to ensure a GOP's current day, next-day and seasonal operations are coordinated with its host BAs and TSP. This requirement relates to planned operations at a generator and does not include unplanned operations such as forced or emergency operations. The SDT recommends that this requirement be applied at the aggregate Facility level for dispersed power producing resources. For example, forecasting available MW at the aggregated Facility level is currently one method used. The SDT does not see any reliability gap in that would prompt this team to apply R3 to any point less than the dispersed power resource aggregated Facility level. *The SDT has not found or been made aware of a reliability gap that would prompt this team to apply R3 to any point less than the dispersed power resource aggregated Facility level and recommends such modification to the applicability of this requirement.*

4.11.3.2 Requirement R13

The purpose of requirement R13 as it relates to GOPs is to ensure Real Power and Reactive Power capabilities are verified as requested by the BA and TOP. The SDT believes a modification to the applicability of this requirement is necessary for dispersed power producing resources. The SDT is recommending that this requirement be applied at the aggregate Facility level for dispersed power producing resources for the following reasons:

- Due to the nature, amount of individual generators at a dispersed power producing resource, internal Real Power losses, and natural inductance and capacitance of dispersed power resource

²¹ Note that TOP-001-2 was adopted by the Board and remanded by FERC. TOP-001-2 is currently under revision as part of Project 2014-03 – Revisions to TOP and IRO Standards, and was posted for additional ballot period that is scheduled to close January 7, 2015 as TOP-001-3.

²² The GOP applicability is removed in TOP-002-3, which was adopted by the Board. However, TOP-002-3 was included in the proposed remand by FERC and is subject to revision as part of Project 2014-3 – Revisions to TOP and IRO Standards.

system connected in series, verification of real and reactive capabilities should be conducted at the dispersed power producing resource aggregate Facility level. Performing verification in this manner will provide an actual net real and reactive capability, which would be seen by both the BA and TOP. In addition, performing verification in this manner is also consistent with operating agreements such as an interconnection agreement, which the dispersed power resource has with the TOP and BA.

- MOD-025-2 also provides that verification for any generator <20MVA may be completed on an individual unit basis or as a “group.” Reporting capability at the aggregated Facility level is consistent with the MOD-025-2 provision for group verification.

The SDT recommends a modification to the applicability of this requirement at the aggregated Facility level for dispersed power producing resources.

4.11.3.3 Requirement R14

The purpose of requirement R14 as it relates to GOPs is to ensure BAs and TOPs are notified of changes in real output capabilities without any intentional time delay. It should be noted that the purpose of this requirement is to address unplanned changes in real output capabilities. It is assumed the required notification and coordination from the GOP to the BA and TOP would be done in real-time and through verbal communication media. The concern here is how to apply this to dispersed power producing resources. The SDT recommends that the GOP notify at the aggregate Facility level to the TOP any unplanned changes in real output capabilities above 20 MVA. The justification is based on the following:

- This is consistent with Inclusion I2 of the revised BES definition which includes generating units greater than 20MVA; and
- TOP-002-2.1b R14 requires real-time notification of changes in Real Power capabilities, planned and unplanned. Setting the threshold at 20 MVA would address routine maintenance on a small portion of the Facility (e.g. 2% of the generators are out of service on any given day) and individual generating units going into a failure. Otherwise, coordinating each individual generating unit outage would burden the TOP without providing an increase in reliability to the interconnected BPS.

Dispersed generation resources changes in real output capabilities should be reported as X MW out of Y MW are available. *The SDT recommends that a modification to the applicability of this requirement is necessary for dispersed power producing resources for unplanned outages greater than 20 MVA.*

4.11.3.4 Requirement R15

The purpose of requirement R15 as it relates to GOPs is to ensure BAs and TOPs are provided a forecast (e.g., seven day) of expected Real Power. The SDT believes this requirement as requested by the BA or TOP is being applied at the aggregate Facility level for dispersed power producing resources.

Based on the SDT’s experience, expected Real Power forecasts (e.g. 5 or 7 forecast) for a dispersed power producing resource has been traditionally coordinated with the BA and TOP at the aggregate Facility level for dispersed power producing resources. *Therefore, the SDT recommends that R15 be applied at the aggregate Facility level for dispersed power resources and as such, modification to the applicability of this requirement is necessary.*

4.11.3.5 Requirement R18

The purpose of requirement R18 as it relates to a GOP is to ensure uniform line identifiers are used when referring to transmission facilities of an interconnected network. The standard applies to transmission facilities of an interconnected network, which would not apply to any Elements within the dispersed generation Facility. There is no need to differentiate applicability to dispersed generation resources from any other GOP resources. *Therefore, the applicability of this requirement does not need to be changed for dispersed generation resources.*

4.11.4 TOP-003-1— Planned Outage Coordination

This TOP Standard has three requirements applied to GOPs. Modification to one of these requirements is recommended.

4.11.4.1 Requirement R1

The purpose of requirement R1 as it relates to GOPs is to ensure TOPs are provided planned outage information on a daily basis for any scheduled generator outage >50MW for the next day. *Therefore, the applicability of this requirement does not need to be changed for dispersed generation resources.*

4.11.4.2 Requirement R2

The purpose of requirement R2 as it relates to GOPs is to ensure all voltage regulating equipment scheduled outages are planned and coordinated with affected BAs and TOPs. A modification to the applicability of this requirement is necessary for dispersed power producing resources. The SDT recommends that this requirement be applied at the aggregate Facility level for dispersed power producing resources.

Based on the SDT's experience, scheduled outages of voltage regulating equipment at a dispersed power producing resource has been traditionally provided to the BA and TOP at the aggregate Facility level for dispersed power producing resources. Outages of voltage regulating equipment at a dispersed power producing resource are coordinated typically as a reduction in Reactive Power capabilities, specifying whether it is inductive, capacitive or both. Additionally, automatic voltage regulators that do not necessarily provide Reactive Power, but direct the actions of equipment that do supply Reactive Power, are typically coordinated at the aggregate Facility level as they usually are the master controller for all voltage regulating equipment at the Facility. A key aspect of the SDT project is to maintain the status quo, if it is determined not to cause a reliability gap. *The SDT has not found or been made aware of a reliability gap, which would prompt this team to apply R2 to any point less than the dispersed power producing resource aggregated Facility level and as such, determined a modification to the applicability of this requirement is necessary for dispersed power producing resources.*

4.11.4.3 Requirement R3

The purpose of requirement R3 as it relates to GOPs is to ensure scheduled outages of telemetering and control equipment and associated communication channels are planned and coordinated among BAs and TOPs. Based on the SDT technical expertise, scheduled outages of telemetering and control equipment and associated communication channels at a dispersed power producing resource have been traditionally provided to the BA and TOP at the aggregate Facility level for dispersed power producing resources. In addition, only scheduled outages of telemetering and control equipment and associated communication

channels that can affect the BA and TOP are coordinated with the BA and TOP. *Therefore, the applicability of this requirement does not need to be changed for dispersed power producing resources.*

4.11.5 TOP-006 — Monitoring System Conditions

The purpose of this standard as it relates to GOPs is to ensure BAs and TOPs know the status of all generation resources available for use as informed by the GOP. It should also be noted that the purpose of this standard is to ensure critical reliability parameters are monitored in real-time. It then can be extrapolated that the requirement, “GOP shall inform...” is done by sending dispersed power producing resource telemetry in real-time and through a digital communication medium, such as an ICCP link or RTU. The SDT feels a modification to the applicability of this requirement is necessary for dispersed power producing resources. The SDT is recommending that this requirement be applied at the aggregate Facility level for dispersed power producing resources for the following reasons:

- This is consistent with Inclusion I2 of the revised BES definition, which includes generating units greater than 20MVA. If removing <20MVA would cause a burden to the BPS, then the threshold for inclusion in the BES would have been less than 20MVA;
- Routine maintenance is frequently completed on a small portion of the entire Facility (e.g. 2% of the generators are out of service on any given day) such as to not have a significant impact to the output capability of the Facility. Additionally, it is not uncommon to have individual generating units at a dispersed power producing resource to go into a failure mode due to internal factors of the equipment, such as hydraulic fluid pressure tolerances, gearbox bearing thermal tolerances, etc. As such, coordinating each individual generating unit outage would burden the TOP without providing an increase in reliability to the interconnected BPS; and
- As this standard requires real-time monitoring, this is most likely completed through a digital medium such as an ICCP link or RTU. The data that a dispersed power resource provides to the BA and TOP in real-time should include the aggregate active power output of the Facility, among other telemetry points. These data specifications are usually outlined in interconnection agreements among the parties.

Based on the SDT technical expertise, BAs and TOPs are informed by the GOP of all generation resources available at the dispersed power producing resource at the aggregate Facility level. Traditionally the dispersed power producing resources are providing the BA and TOP, at minimum, the following telemetry points in real-time: aggregate Real Power, aggregate Reactive Power and main high-side circuit breaker status. A key aspect of the SDT project is to maintain the status quo, if it is determined not to cause a reliability gap. *The SDT has not found or been made aware of a reliability gap, which would prompt this team to apply these requirement to any point less than where the dispersed power producing resource aggregates and as in such, recommends a modification to the applicability of this requirement is necessary for dispersed power producing resources.*

4.12 TPL

At the time of this paper, these standards do not affect GOs or GOPs directly. Input from GO or GOP entities is provided to transmission planning entities through the MOD standards. *Therefore, the applicability of the TPL standards does not need to be changed for dispersed power producing resources.*

4.13 VAR

The VAR standards exist to ensure that voltage levels, reactive flows, and reactive resources are monitored, controlled, and maintained. There are two VAR Standards that apply to GOs and/or GOPs. The voltage and/or reactive schedule provided by TOPs is specified to be at the point of interconnection or the point specified in the interconnection agreement.

4.13.1 VAR-001 — Voltage and Reactive Control (WECC Regional Variance)

The purpose of this standard as it relates to GOPs in WECC is to ensure a generator voltage schedule is issued that is appropriate for the type of generator(s) at a specific Facility. Additionally, it requires GOPs to have a methodology for how the voltage schedule is met taking into account the type of equipment used to maintain the voltage schedule. Based on the SDT technical expertise, voltage control and voltage schedule adherence for dispersed power producing resource occurs at the aggregate Facility level. There is no need to differentiate dispersed generation resources from any other GOP resources. *Therefore, the applicability of VAR-001 does not need to be changed for dispersed generation resources.*

4.13.2 VAR-002-2b — Generator Operation for Maintaining Network Voltage Schedules VAR-002-3 — Generator Operation for Maintaining Network Voltage Schedules

The purpose of these standards as they relate to GOs and GOPs is to ensure generators operate in automatic voltage control mode as required by the TOP voltage or reactive power schedule provided to ensure voltage levels, reactive flows, and reactive resources are maintained within applicable Facility Ratings to protect equipment and reliability of the Interconnection. Based on the SDT technical expertise, voltage control and voltage schedule adherence for dispersed power producing resource occurs at the aggregate Facility level and such guidance should be provided.

In addition, the voltage-controlling equipment and the methodology to ensure the Facility has an automatic and dynamic response to ensure the TOP's instructions are maintained can be very different for each Facility. It is implied in VAR-001-3 that each TOP should understand capabilities of the generation Facility and the requirements of the transmission system to ensure a mutually agreeable solution/schedule is used.

**4.13.3 VAR-002-2b — Requirement R3.1
VAR-002-3 — Requirement R4**

**4.13.4 The purpose of these requirements is to ensure that a GOP notifies the TOP, within 30 minutes, any status and capability changes of any generator Reactive Power resource, including automatic voltage regulator, power system stabilizer or alternative voltage controlling device. Based on the experience of the SDT, status and capability changes is traditionally coordinated at the aggregate Facility level point of interconnection. Therefore, the SDT has recommended changes to the standard to clarify the applicability of VAR-002-2b R3.1 and VAR-002-3 R4 for dispersed power producing resources. These changes were successfully balloted in VAR-002-4 on November 6, 2014, and approved by the Board on November 13, 2014. VAR-002-2b — Requirement R4
VAR-002-3 — Requirement R5**

The purpose of these requirements is to ensure that Transmission Operators and Transmission Planners have appropriate information and provide guidance to the GOP in regards to Generator Operator's transformers to ensure voltage levels, reactive flows, and reactive resources are maintained within applicable Facility Ratings to protect equipment and reliability of the Interconnection. Based on the experience of the SDT dispersed power producing resources individual generator transformers have traditionally been excluded from the requirements of VAR-002-2b R4 and VAR-002-3 R5, as they are not used to improve voltage performance on the Interconnection. As such, applicability should be limited to transformers with at least one winding at a voltage of 100kV or above. *Therefore, the SDT has recommended changes to the standard to clarify the applicability of VAR-002-2b R4 and VAR-002-3 R5 for dispersed generation resources. These changes were successfully balloted in VAR-002-4 on November 6, 2014, and approved by the Board on November 13, 2014.*

4.14 CIP

4.14.1 CIP v5

The CIP standards are still under revision in Project 2014-02. The DGR SDT and the CIP SDT continue to coordinate revisions to the CIP standards, and will update this section to reflect the outcome of that effort at the appropriate time.

The CIP standards ensure physical and cyber security for BES Cyber Assets and BES Cyber Systems critical to the reliability and security of the BES. CIP-002 identifies critical assets or systems of a Facility, while CIP-003 to CIP-011 depend on the outcome of the CIP-002 assessment to determine applicability.

During the Project 2014-02 CIP Version 5 Revisions SDT first comment period, it received comments to modify CIP-003-6 in the Applicability Section. The CIP SDT made drastic modifications to the second posting of CIP-003-6 to take into accounts all of the comments received, which was posted for an additional 45-day comment and ballot period on September 3, 2014.

At its September meeting, the DGR SDT had a focused discussion with the CIP SDT surrounding the technical nature of the dispersed power producing resources and how it relates to the CIP standards. The coordinating effort resulted in discussions of the revised CIP-003-6. As for that posted revised standard,

the CIP SDT took the approach of including an Attachment 1 for Responsible Entities. The Attachment 1 requires elements to be developed in Responsible Entities' cyber security plan(s) for assets containing low impact BES Cyber Systems. The elements in CIP-003-6, Attachment 1 allow flexibility for the controls to be established for each of the main four elements below. The CIP SDT encourages observers of the DGR SDT to review the Attachment 1 in detail. Here is some information regarding the attachment.

Element 1: Security Awareness

The intent of the security awareness program is for entities to reinforce good cyber security practices with their personnel at least once every 15 calendar months. It is up to the entity as to the topics and how it schedules these topics. The Responsible Entity should be able to produce the awareness material that was delivered and the delivery method(s) (posters, emails, topics at staff meetings, etc.) that were used. The SDT does not intend that the Responsible Entity must maintain lists of recipients and track the reception of the awareness material by personnel.

Element 2: Physical Security

The Responsible Entity has flexibility in the controls used to restrict physical access to low impact BES Cyber Systems at a BES asset using one or a combination of access controls, monitoring controls, or other operational, procedural, or technical physical security controls. Entities may utilize perimeter controls (e.g., fences with locked gates, guards, site access policies, etc.) and/or more granular areas of physical access control in areas where low impact BES Cyber Systems are located, such as control rooms or control houses. User authorization programs and lists of authorized users are not required.

Element 3: Electronic Access Controls

Where Low Impact External Routable Connectivity (LERC) or Dial-up Connectivity exists, the Responsible Entity must document and implement controls that include the LERC and Dial-up Connectivity to the BES asset such that the low impact BES Cyber Systems located at the BES asset are protected. Two glossary terms are included in order to help clarify and simplify the language in Attachment 1. The SDT's intent in creating these terms is to avoid confusion with the similar concepts and requirements (ESP, EAP, ERC, EACMS) needed for high and medium impact BES Cyber Systems by utilizing separate terms that apply only to assets containing low impact BES Cyber Systems.

Element 4: Cyber Security Incident Response

The entity should have one or more documented cyber security incident response plans that include each of the topics listed. For assets that do not have LERC, it is not the intent to increase their risk by increasing the level of connectivity in order to have real-time monitoring. The intent is if in the normal course of business suspicious activities are noted at an asset containing low impact BES Cyber Systems, there is a cyber security incident response plan that will guide the entity through responding to the incident and reporting the incident if it rises to the level of a Reportable Cyber Security Incident.

Therefore, the DGR SDT recommends that no changes be made to proposed CIP-003-6. CIP-002-5.1 needs to remain as is because entities must go through the process for identifying and categorizing its BES Cyber Systems and their associated BES Cyber Assets. The controls put in place for proposed CIP-003-6, Attachment 1, are not burdensome, are realistic and achievable, and does not express undue

compliance burden. In conclusion, the DGR SDT states that the reliability objective of these controls are adequate and the applicability of CIP-003-6 should not be modified.

The SDT states that the CIP Version 5 Revisions SDT should consider developing guidance documentation around the following areas:

- Low Impact BES Cyber Systems that must comply with a limited number of requirements, all located in CIP-003-5. The only technical requirement is R2, which will be modified during the current drafting activity to add clarity to the requirement. The SDT notes that the CIP Version 5 Revisions SDT should consider developing guidance around how this requirement relates to dispersed generation;
- Any programmable logic device that has the capability to shut down the plant within 15 minutes; and
- Remote access from third party entities into the SCADA systems that control the aggregate capacity of a Facility should be assessed to determine if there is a need of any additional cyber security policies.

The SDT intends to recommend guidance for those companies that only operate their turbines from one central location. Individual Elements lumped into a BES Cyber System should be addressed. When operations are on a turbine-by-turbine basis, the SDT believes there should not be rigid controls in place. The inability to “swim upstream” should be addressed as well. Further, the guidance intends to address when manufacturers operate or have control of the SCADA environment to conduct troubleshooting and other tasks, and ensure that proper security is in place.

NERC staff has committed to facilitate communication between the SDT and the CIP Version 5 Revisions SDT as appropriate to ensure alignment and to develop language for guidance, coordinated between the two SDTs. *Therefore, the applicability of CIP standards does not need to be changed for dispersed generation resources.*

Appendix A: List of Standards

Appendix B: List of Standards Recommended for Further Review

Appendix A- List of all NERC standards
applicable to GOs/GOPs

Standard Number	Status	Further Review by SDT	Regional
BAL-001-1	Subject to Enforcement	No	No
BAL-001-TRE-1	Subject to Enforcement	Yes	Yes
BAL-002-1	Subject to Enforcement	No	No
BAL-002-WECC-2	Subject to Enforcement	No	Yes
BAL-003-0.1b	Subject to Enforcement	No	No
BAL-004-0	Subject to Enforcement	No	No
BAL-004-WECC-02	Subject to Enforcement	No	Yes
BAL-005-0.2b	Subject to Enforcement	No	No
BAL-006-2	Subject to Enforcement	No	No
BAL-502-RFC-02	Subject to Enforcement	No	Yes
CIP-002-3	Subject to Enforcement	No	No
CIP-003-3	Subject to Enforcement	No	No
CIP-004-3a	Subject to Enforcement	No	No
CIP-005-3a	Subject to Enforcement	No	No
CIP-006-3c	Subject to Enforcement	No	No
CIP-007-3a	Subject to Enforcement	No	No
CIP-008-3	Subject to Enforcement	No	No
CIP-009-3	Subject to Enforcement	No	No
COM-001-1.1	Subject to Enforcement	No	No
COM-002-2	Subject to Enforcement	No	No
EOP-001-2.1b	Subject to Enforcement	No	No
EOP-002-3.1	Subject to Enforcement	No	No
EOP-003-2	Subject to Enforcement	No	No
EOP-004-2	Subject to Enforcement	Yes	No
EOP-005-2	Subject to Enforcement	No	No
EOP-006-2	Subject to Enforcement	No	No
EOP-008-1	Subject to Enforcement	No	No
FAC-001-1	Subject to Enforcement	No	No
FAC-002-1	Subject to Enforcement	No	No
FAC-003-3	Subject to Enforcement	No	No
FAC-008-3	Subject to Enforcement	Yes	No
FAC-010-2.1	Subject to Enforcement	No	No
FAC-011-2	Subject to Enforcement	No	No
FAC-013-2	Subject to Enforcement	No	No
FAC-014-2	Subject to Enforcement	No	No
FAC-501-WECC-1	Subject to Enforcement	No	Yes
INT-004-3	Subject to Enforcement	No	No
INT-006-4	Subject to Enforcement	No	No
INT-009-2	Subject to Enforcement	No	No
INT-010-2	Subject to Enforcement	No	No
INT-011-1	Subject to Enforcement	No	No
IRO-001-1.1	Subject to Enforcement	No	No
IRO-002-2	Subject to Enforcement	No	No
IRO-003-2	Subject to Enforcement	No	No
IRO-004-2	Subject to Enforcement	No	No
IRO-005-3.1a	Subject to Enforcement	No	No
IRO-006-5	Subject to Enforcement	No	No
IRO-006-EAST-1	Subject to Enforcement	No	Yes
IRO-006-TRE-1	Subject to Enforcement	No	Yes
IRO-006-WECC-2	Subject to Enforcement	No	Yes
IRO-008-1	Subject to Enforcement	No	No
IRO-009-1	Subject to Enforcement	No	No
IRO-010-1a	Subject to Enforcement	No	No
IRO-014-1	Subject to Enforcement	No	No
IRO-015-1	Subject to Enforcement	No	No
IRO-016-1	Subject to Enforcement	No	No
MOD-001-1a	Subject to Enforcement	No	No
MOD-004-1	Subject to Enforcement	No	No
MOD-008-1	Subject to Enforcement	No	No
MOD-010-0	Subject to Enforcement	No	No

**Note: Make sure
"Appendix A
Source" is correct.
This table will auto-
populate.**

**Zeroes indicate
missing value on
"Appendix A
Source".**

MOD-012-0	Subject to Enforcement	No	No
MOD-016-1.1	Subject to Enforcement	No	No
MOD-017-0.1	Subject to Enforcement	No	No
MOD-018-0	Subject to Enforcement	No	No
MOD-019-0.1	Subject to Enforcement	No	No
MOD-020-0	Subject to Enforcement	No	No
MOD-021-1	Subject to Enforcement	No	No
MOD-026-1	Subject to Enforcement	Yes	No
MOD-027-1	Subject to Enforcement	Yes	No
MOD-028-2	Subject to Enforcement	No	No
MOD-029-1a	Subject to Enforcement	No	No
MOD-030-2	Subject to Enforcement	No	No
NUC-001-2.1	Subject to Enforcement	No	No
PER-001-0.2	Subject to Enforcement	No	No
PER-003-1	Subject to Enforcement	No	No
PER-004-2	Subject to Enforcement	No	No
PER-005-1	Subject to Enforcement	No	No
PRC-001-1.1	Subject to Enforcement	Yes	No
PRC-002-NPCC-01	Subject to Enforcement	No	Yes
PRC-004-2.1a	Subject to Enforcement	Yes	No
PRC-004-WECC-1	Subject to Enforcement	Yes	Yes
PRC-005-1.1b	Subject to Enforcement	Yes	No
PRC-006-1	Subject to Enforcement	No	No
PRC-006-SERC-01	Subject to Enforcement	Yes	Yes
PRC-008-0	Subject to Enforcement	No	No
PRC-010-0	Subject to Enforcement	No	No
PRC-011-0	Subject to Enforcement	No	No
PRC-015-0	Subject to Enforcement	No	No
PRC-016-0.1	Subject to Enforcement	No	No
PRC-017-0	Subject to Enforcement	No	No
PRC-018-1	Subject to Enforcement	No	No
PRC-021-1	Subject to Enforcement	No	No
PRC-022-1	Subject to Enforcement	No	No
PRC-023-3	Subject to Enforcement	No	No
PRC-025-1	Subject to Enforcement	Yes	No
TOP-001-1a	Subject to Enforcement	Yes	No
TOP-002-2.1b	Subject to Enforcement	Yes	No
TOP-003-1	Subject to Enforcement	Yes	No
TOP-004-2	Subject to Enforcement	No	No
TOP-005-2a	Subject to Enforcement	No	No
TOP-006-2	Subject to Enforcement	Yes	No
TOP-007-0	Subject to Enforcement	No	No
TOP-007-WECC-1a	Subject to Enforcement	No	Yes
TOP-008-1	Subject to Enforcement	No	No
TPL-001-0.1	Subject to Enforcement	No	No
TPL-002-0b	Subject to Enforcement	No	No
TPL-003-0b	Subject to Enforcement	No	No
TPL-004-0a	Subject to Enforcement	No	No
VAR-001-4	Subject to Enforcement	No	No
VAR-002-3	Subject to Enforcement	Yes	No
VAR-002-WECC-1	Subject to Enforcement	No	Yes
VAR-501-WECC-1	Subject to Enforcement	No	Yes
BAL-003-1	Subject to Future Enforcement	No	No
CIP-002-5.1	Subject to Future Enforcement	No	No
CIP-003-5	Subject to Future Enforcement	No	No
CIP-004-5.1	Subject to Future Enforcement	No	No
CIP-005-5	Subject to Future Enforcement	No	No
CIP-006-5	Subject to Future Enforcement	No	No
CIP-007-5	Subject to Future Enforcement	No	No
CIP-008-5	Subject to Future Enforcement	No	No
CIP-009-5	Subject to Future Enforcement	No	No

CIP-010-1	Subject to Future Enforcement	No	No
CIP-011-1	Subject to Future Enforcement	No	No
CIP-014-1	Subject to Future Enforcement	No	No
EOP-010-1	Subject to Future Enforcement	No	No
FAC-001-2	Subject to Future Enforcement	No	No
FAC-002-2	Subject to Future Enforcement	No	No
MOD-025-2	Subject to Future Enforcement	Yes	No
MOD-032-1	Subject to Future Enforcement	Yes	No
MOD-033-1	Subject to Future Enforcement	No	No
NUC-001-3	Subject to Future Enforcement	No	No
PER-005-2	Subject to Future Enforcement	No	No
PRC-005-2	Subject to Future Enforcement	Yes	No
PRC-006-NPCC-1	Subject to Future Enforcement	Yes	Yes
PRC-019-1	Subject to Future Enforcement	Yes	No
PRC-024-1	Subject to Future Enforcement	Yes	No
TPL-001-4	Subject to Future Enforcement	No	No
BAL-001-2	Pending Regulatory Approval	No	No
BAL-002-1a	Pending Regulatory Approval	No	No
COM-001-2	Pending Regulatory Approval	No	No
COM-002-4	Pending Regulatory Approval	No	No
MOD-001-2	Pending Regulatory Approval	No	No
MOD-011-0	Pending Regulatory Approval	No	No
MOD-013-1	Pending Regulatory Approval	No	No
MOD-014-0	Pending Regulatory Approval	No	No
MOD-015-0	Pending Regulatory Approval	No	No
MOD-031-1	Pending Regulatory Approval	No	No
PRC-002-1	Pending Regulatory Approval	No	No
PRC-003-1	Pending Regulatory Approval	No	No
PRC-004-3	Pending Regulatory Approval	Yes	No
PRC-005-3	Pending Regulatory Approval	Yes	No
PRC-012-0	Pending Regulatory Approval	No	No
PRC-013-0	Pending Regulatory Approval	No	No
PRC-014-0	Pending Regulatory Approval	No	No
PRC-020-1	Pending Regulatory Approval	No	No
TOP-006-3	Pending Regulatory Approval	Yes	No
TPL-001-3	Pending Regulatory Approval	No	No
TPL-002-2b	Pending Regulatory Approval	No	No
TPL-003-2a	Pending Regulatory Approval	No	No
TPL-004-2	Pending Regulatory Approval	No	No
TPL-005-0	Pending Regulatory Approval	No	No
CIP-002-3b	Pending Regulatory Filing	No	No
CIP-003-3a	Pending Regulatory Filing	No	No
CIP-007-3b	Pending Regulatory Filing	No	No
COM-002-2a	Pending Regulatory Filing	No	No
IRO-001-4	Pending Regulatory Filing	No	No
IRO-002-4	Pending Regulatory Filing	No	No
IRO-008-2	Pending Regulatory Filing	No	No
IRO-010-2	Pending Regulatory Filing	No	No
IRO-014-3	Pending Regulatory Filing	No	No
IRO-017-1	Pending Regulatory Filing	0	No
TOP-002-4	Pending Regulatory Filing	Yes	No
TOP-003-3	Pending Regulatory Filing	Yes	No
IRO-001-3	*See Project 2014-03	Yes	No
IRO-002-3	*See Project 2014-03	No	No
IRO-005-4	*See Project 2014-03	Yes	No
IRO-014-2	*See Project 2014-03	No	No
PRC-001-2	*See Project 2014-03	Yes	No
TOP-001-2	*See Project 2014-03	Yes	No
TOP-002-3	*See Project 2014-03	Yes	No
TOP-003-2	*See Project 2014-03	Yes	No
MOD-024-1	Designated for Retirement	No	No
MOD-025-1	Designated for Retirement	No	No

Status	Number of Standards	Number of Standards to be Addressed (Standard, RSAW, Guidance or Further Review)
NERC Standards	168	24
Subject to Enforcement	98	13
Subject to Future Enforcement	24	5
Pending Regulatory Approval	24	3
Pending Regulatory Filing	12	3
Designated for Retirement	2	0
Proposed for Remand	8	0
Region-specific Standards (*Out of Scope)	15	4
Subject to Enforcement	14	3
Subject to Future Enforcement	1	1
Pending Regulatory Approval	0	0
Grand Total	183	28

Note: Make sure "Appendix A Source" is complete. This table will auto-populate.

Priority	Standard Number	Area To Change	Target Applicability
High	PRC-004-2.1a	Applicability Section	Misoperations affecting >75MVA
High	PRC-004-3	Applicability Section	Misoperations affecting >75MVA
High	PRC-005-1.1b	Guidance	Point where aggregates to >75MVA
High	PRC-005-2	Applicability Section	Point where aggregates to >75MVA
High	PRC-005-3	Applicability Section	Point where aggregates to >75MVA
High	VAR-002-3	Applicability Section& Footnote	Aggregate Facility Level for Voltage Control; Transmission voltage GSUs
Medium	EOP-004-2	No Action	NA
Medium	FAC-008-3	Guidance	Individual BES Resources /Elements to Include Aggregating Equipment
Medium	IRO-017-1	TBD	TBD
Medium	MOD-025-2	No Action	NA
Medium	MOD-026-1	No Action	NA
Medium	MOD-027-1	No Action	NA
Medium	MOD-032-1	No Action	NA
Medium	PRC-001-1.1	Applicability Section	Aggregate Facility Level
Medium	PRC-019-1	Applicability Section	Individual BES Resources/Elements
Medium	PRC-024-1	By Requirement	Individual BES Resources /Elements to Include Aggregating Equipment
Medium	PRC-025-1	Guidance	Individual BES Resources /Elements to Include Aggregating Equipment
Medium	TOP-001-1a	No Action	NA
Medium	TOP-002-2.1b	Applicability Section	Aggregate Facility Level
Medium	TOP-002-4	TBD	TBD
Medium	TOP-003-1	By Requirement	Aggregate Facility Level
Medium	TOP-003-3	TBD	TBD
Medium	TOP-006-2	No Action	NA
Medium	TOP-006-3	TBD	TBD
Low	BAL-001-TRE-1	Applicability Section	Aggregate Facility Level
Low	PRC-004-WECC-1	Applicability Section	Point where aggregates to >75MVA
Low	PRC-006-NPCC-1	By Requirement	Individual BES Resources/Elements
Low	PRC-006-SERC-01	By Requirement	Individual BES Resources/Elements
0	0	0	0
0	0	0	0
0	0	v cells. Ensure rest aligns with the pap	0
0	0	0	0
0	0	0	0
0	0	0	0

Note: Make sure "Appendix B Source" is correct. This table will auto-populate.

Zeros indicate missing value on "Appendix B Source".

Appendix B- NERC standards
recommended for consideration to clarify
applicability for dispersed generation

Standard Number	Status	Further Review by SDT	Regional
BAL-001-1	Subject to Enforcement	No	No
BAL-001-TRE-1	Subject to Enforcement	Yes	Yes
BAL-002-1	Subject to Enforcement	No	No
BAL-002-WECC-2	Subject to Enforcement	No	Yes
BAL-003-0.1b	Subject to Enforcement	No	No
BAL-004-0	Subject to Enforcement	No	No
BAL-004-WECC-02	Subject to Enforcement	No	Yes
BAL-005-0.2b	Subject to Enforcement	No	No
BAL-006-2	Subject to Enforcement	No	No
BAL-502-RFC-02	Subject to Enforcement	No	Yes
CIP-002-3	Subject to Enforcement	No	No
CIP-003-3	Subject to Enforcement	No	No
CIP-004-3a	Subject to Enforcement	No	No
CIP-005-3a	Subject to Enforcement	No	No
CIP-006-3c	Subject to Enforcement	No	No
CIP-007-3a	Subject to Enforcement	No	No
CIP-008-3	Subject to Enforcement	No	No
CIP-009-3	Subject to Enforcement	No	No
COM-001-1.1	Subject to Enforcement	No	No
COM-002-2	Subject to Enforcement	No	No
EOP-001-2.1b	Subject to Enforcement	No	No
EOP-002-3.1	Subject to Enforcement	No	No
EOP-003-2	Subject to Enforcement	No	No
EOP-004-2	Subject to Enforcement	Yes	No
EOP-005-2	Subject to Enforcement	No	No
EOP-006-2	Subject to Enforcement	No	No
EOP-008-1	Subject to Enforcement	No	No
FAC-001-1	Subject to Enforcement	No	No
FAC-002-1	Subject to Enforcement	No	No
FAC-003-3	Subject to Enforcement	No	No
FAC-008-3	Subject to Enforcement	Yes	No
FAC-010-2.1	Subject to Enforcement	No	No
FAC-011-2	Subject to Enforcement	No	No
FAC-013-2	Subject to Enforcement	No	No
FAC-014-2	Subject to Enforcement	No	No
FAC-501-WECC-1	Subject to Enforcement	No	Yes
INT-004-3	Subject to Enforcement	No	No
INT-006-4	Subject to Enforcement	No	No
INT-009-2	Subject to Enforcement	No	No
INT-010-2	Subject to Enforcement	No	No
INT-011-1	Subject to Enforcement	No	No
IRO-001-1.1	Subject to Enforcement	No	No
IRO-002-2	Subject to Enforcement	No	No
IRO-003-2	Subject to Enforcement	No	No
IRO-004-2	Subject to Enforcement	No	No
IRO-005-3.1a	Subject to Enforcement	No	No
IRO-006-5	Subject to Enforcement	No	No
IRO-006-EAST-1	Subject to Enforcement	No	Yes
IRO-006-TRE-1	Subject to Enforcement	No	Yes
IRO-006-WECC-2	Subject to Enforcement	No	Yes
IRO-008-1	Subject to Enforcement	No	No
IRO-009-1	Subject to Enforcement	No	No
IRO-010-1a	Subject to Enforcement	No	No
IRO-014-1	Subject to Enforcement	No	No
IRO-015-1	Subject to Enforcement	No	No
IRO-016-1	Subject to Enforcement	No	No
MOD-001-1a	Subject to Enforcement	No	No
MOD-004-1	Subject to Enforcement	No	No
MOD-008-1	Subject to Enforcement	No	No
MOD-010-0	Subject to Enforcement	No	No

Note: Make sure "Appendix A Source" is correct. This table will auto-populate.

Zeroes indicate missing value on "Appendix A Source".

MOD-012-0	Subject to Enforcement	No	No
MOD-016-1.1	Subject to Enforcement	No	No
MOD-017-0.1	Subject to Enforcement	No	No
MOD-018-0	Subject to Enforcement	No	No
MOD-019-0.1	Subject to Enforcement	No	No
MOD-020-0	Subject to Enforcement	No	No
MOD-021-1	Subject to Enforcement	No	No
MOD-026-1	Subject to Enforcement	Yes	No
MOD-027-1	Subject to Enforcement	Yes	No
MOD-028-2	Subject to Enforcement	No	No
MOD-029-1a	Subject to Enforcement	No	No
MOD-030-2	Subject to Enforcement	No	No
NUC-001-2.1	Subject to Enforcement	No	No
PER-001-0.2	Subject to Enforcement	No	No
PER-003-1	Subject to Enforcement	No	No
PER-004-2	Subject to Enforcement	No	No
PER-005-1	Subject to Enforcement	No	No
PRC-001-1.1	Subject to Enforcement	Yes	No
PRC-002-NPCC-01	Subject to Enforcement	No	Yes
PRC-004-2.1a	Subject to Enforcement	Yes	No
PRC-004-WECC-1	Subject to Enforcement	Yes	Yes
PRC-005-1.1b	Subject to Enforcement	Yes	No
PRC-006-1	Subject to Enforcement	No	No
PRC-006-SERC-01	Subject to Enforcement	Yes	Yes
PRC-008-0	Subject to Enforcement	No	No
PRC-010-0	Subject to Enforcement	No	No
PRC-011-0	Subject to Enforcement	No	No
PRC-015-0	Subject to Enforcement	No	No
PRC-016-0.1	Subject to Enforcement	No	No
PRC-017-0	Subject to Enforcement	No	No
PRC-018-1	Subject to Enforcement	No	No
PRC-021-1	Subject to Enforcement	No	No
PRC-022-1	Subject to Enforcement	No	No
PRC-023-3	Subject to Enforcement	No	No
PRC-025-1	Subject to Enforcement	Yes	No
TOP-001-1a	Subject to Enforcement	Yes	No
TOP-002-2.1b	Subject to Enforcement	Yes	No
TOP-003-1	Subject to Enforcement	Yes	No
TOP-004-2	Subject to Enforcement	No	No
TOP-005-2a	Subject to Enforcement	No	No
TOP-006-2	Subject to Enforcement	Yes	No
TOP-007-0	Subject to Enforcement	No	No
TOP-007-WECC-1a	Subject to Enforcement	No	Yes
TOP-008-1	Subject to Enforcement	No	No
TPL-001-0.1	Subject to Enforcement	No	No
TPL-002-0b	Subject to Enforcement	No	No
TPL-003-0b	Subject to Enforcement	No	No
TPL-004-0a	Subject to Enforcement	No	No
VAR-001-4	Subject to Enforcement	No	No
VAR-002-3	Subject to Enforcement	Yes	No
VAR-002-WECC-1	Subject to Enforcement	No	Yes
VAR-501-WECC-1	Subject to Enforcement	No	Yes
BAL-003-1	Subject to Future Enforcement	No	No
CIP-002-5.1	Subject to Future Enforcement	No	No
CIP-003-5	Subject to Future Enforcement	No	No
CIP-004-5.1	Subject to Future Enforcement	No	No
CIP-005-5	Subject to Future Enforcement	No	No
CIP-006-5	Subject to Future Enforcement	No	No
CIP-007-5	Subject to Future Enforcement	No	No
CIP-008-5	Subject to Future Enforcement	No	No
CIP-009-5	Subject to Future Enforcement	No	No

CIP-010-1	Subject to Future Enforcement	No	No
CIP-011-1	Subject to Future Enforcement	No	No
CIP-014-1	Subject to Future Enforcement	No	No
EOP-010-1	Subject to Future Enforcement	No	No
FAC-001-2	Subject to Future Enforcement	No	No
FAC-002-2	Subject to Future Enforcement	No	No
MOD-025-2	Subject to Future Enforcement	Yes	No
MOD-032-1	Subject to Future Enforcement	Yes	No
MOD-033-1	Subject to Future Enforcement	No	No
NUC-001-3	Subject to Future Enforcement	No	No
PER-005-2	Subject to Future Enforcement	No	No
PRC-005-2	Subject to Future Enforcement	Yes	No
PRC-006-NPCC-1	Subject to Future Enforcement	Yes	Yes
PRC-019-1	Subject to Future Enforcement	Yes	No
PRC-024-1	Subject to Future Enforcement	Yes	No
TPL-001-4	Subject to Future Enforcement	No	No
BAL-001-2	Pending Regulatory Approval	No	No
BAL-002-1a	Pending Regulatory Approval	No	No
COM-001-2	Pending Regulatory Approval	No	No
COM-002-4	Pending Regulatory Approval	No	No
MOD-001-2	Pending Regulatory Approval	No	No
MOD-011-0	Pending Regulatory Approval	No	No
MOD-013-1	Pending Regulatory Approval	No	No
MOD-014-0	Pending Regulatory Approval	No	No
MOD-015-0	Pending Regulatory Approval	No	No
MOD-031-1	Pending Regulatory Approval	No	No
PRC-002-1	Pending Regulatory Approval	No	No
PRC-003-1	Pending Regulatory Approval	No	No
PRC-004-3	Pending Regulatory Approval	Yes	No
PRC-005-3	Pending Regulatory Approval	Yes	No
PRC-012-0	Pending Regulatory Approval	No	No
PRC-013-0	Pending Regulatory Approval	No	No
PRC-014-0	Pending Regulatory Approval	No	No
PRC-020-1	Pending Regulatory Approval	No	No
TOP-006-3	Pending Regulatory Approval	Yes	No
TPL-001-3	Pending Regulatory Approval	No	No
TPL-002-2b	Pending Regulatory Approval	No	No
TPL-003-2a	Pending Regulatory Approval	No	No
TPL-004-2	Pending Regulatory Approval	No	No
TPL-005-0	Pending Regulatory Approval	No	No
CIP-002-3b	Pending Regulatory Filing	No	No
CIP-003-3a	Pending Regulatory Filing	No	No
CIP-007-3b	Pending Regulatory Filing	No	No
COM-002-2a	Pending Regulatory Filing	No	No
IRO-001-4	Pending Regulatory Filing	No	No
IRO-002-4	Pending Regulatory Filing	No	No
IRO-008-2	Pending Regulatory Filing	No	No
IRO-010-2	Pending Regulatory Filing	No	No
IRO-014-3	Pending Regulatory Filing	No	No
IRO-017-1	Pending Regulatory Filing	0	No
TOP-002-4	Pending Regulatory Filing	Yes	No
TOP-003-3	Pending Regulatory Filing	Yes	No
IRO-001-3	*See Project 2014-03	Yes	No
IRO-002-3	*See Project 2014-03	No	No
IRO-005-4	*See Project 2014-03	Yes	No
IRO-014-2	*See Project 2014-03	No	No
PRC-001-2	*See Project 2014-03	Yes	No
TOP-001-2	*See Project 2014-03	Yes	No
TOP-002-3	*See Project 2014-03	Yes	No
TOP-003-2	*See Project 2014-03	Yes	No
MOD-024-1	Designated for Retirement	No	No
MOD-025-1	Designated for Retirement	No	No

Status	Number of Standards	Number of Standards to be Addressed (Standard, RSAW, Guidance or Further Review)
NERC Standards	168	24
Subject to Enforcement	98	13
Subject to Future Enforcement	24	5
Pending Regulatory Approval	24	3
Pending Regulatory Filing	12	3
Designated for Retirement	2	0
Proposed for Remand	8	0
Region-specific Standards (*Out of Scope)	15	4
Subject to Enforcement	14	3
Subject to Future Enforcement	1	1
Pending Regulatory Approval	0	0
Grand Total	183	28

Note: Make sure "Appendix A Source" is complete. This table will auto-populate.

Priority	Standard Number	Area To Change	Target Applicability
High	PRC-004-2.1a	Applicability Section	Misoperations affecting >75MVA
High	PRC-004-3	Applicability Section	Misoperations affecting >75MVA
High	PRC-005-1.1b	Guidance	Point where aggregates to >75MVA
High	PRC-005-2	Applicability Section	Point where aggregates to >75MVA
High	PRC-005-3	Applicability Section	Point where aggregates to >75MVA
High	VAR-002-3	Applicability Section& Footnote	Aggregate Facility Level for Voltage Control; Transmission voltage GSUs
Medium	EOP-004-2	No Action	NA
Medium	FAC-008-3	Guidance	Individual BES Resources /Elements to Include Aggregating Equipment
Medium	IRO-017-1	TBD	TBD
Medium	MOD-025-2	No Action	NA
Medium	MOD-026-1	No Action	NA
Medium	MOD-027-1	No Action	NA
Medium	MOD-032-1	No Action	NA
Medium	PRC-001-1.1	Applicability Section	Aggregate Facility Level
Medium	PRC-019-1	Applicability Section	Individual BES Resources/Elements
Medium	PRC-024-1	By Requirement	Individual BES Resources /Elements to Include Aggregating Equipment
Medium	PRC-025-1	Guidance	Individual BES Resources /Elements to Include Aggregating Equipment
Medium	TOP-001-1a	No Action	NA
Medium	TOP-002-2.1b	Applicability Section	Aggregate Facility Level
Medium	TOP-002-4	TBD	TBD
Medium	TOP-003-1	By Requirement	Aggregate Facility Level
Medium	TOP-003-3	TBD	TBD
Medium	TOP-006-2	No Action	NA
Medium	TOP-006-3	TBD	TBD
Low	BAL-001-TRE-1	Applicability Section	Aggregate Facility Level
Low	PRC-004-WECC-1	Applicability Section	Point where aggregates to >75MVA
Low	PRC-006-NPCC-1	By Requirement	Individual BES Resources/Elements
Low	PRC-006-SERC-01	By Requirement	Individual BES Resources/Elements
0	0	0	0
0	0	0	0
0	0	w cells. Ensure rest aligns with the pap	0
0	0	0	0
0	0	0	0
0	0	0	0

Note: Make sure "Appendix B Source" is correct. This table will auto-populate.

Zeros indicate missing value on "Appendix B Source".

Subject to Future Enforcement	PRC-024-1	Yes	Generator Frequency and Voltage Protective Relay Settings	0	0	0	0	1	0	1	0	0	0	0	0	0	0	0	0	0	0	0	0	0	1	
Subject to Future Enforcement	TPL-001-4	No	Transmission System Planning Performance Requirements	0	0	0	0	1	0	1	0	0	0	0	0	0	0	0	0	0	0	0	0	0	1	
Pending Regulatory Approval	BAL-001-2	No	Real Power Balancing Control Performance	0	0	0	0	0	0	0	0	1	0	1	0	0	0	0	0	0	0	0	0	0	1	
Pending Regulatory Approval	BAL-002-1a	No	Disturbance Control Performance	0	0	0	0	0	0	0	0	1	0	1	0	0	0	0	0	0	0	0	0	0	1	
Pending Regulatory Approval	COM-001-2	No	Communications	0	0	0	0	0	0	0	0	1	0	1	0	0	0	0	0	0	0	0	0	0	1	
Pending Regulatory Approval	COM-002-4	No	Operating Personnel Communications Protocols	0	0	0	0	0	0	0	0	1	0	1	0	0	0	0	0	0	0	0	0	0	1	
Pending Regulatory Approval	MOD-001-2	No	Available Transmission System Capability	0	0	0	0	0	0	0	0	1	0	1	0	0	0	0	0	0	0	0	0	0	1	
Pending Regulatory Approval	MOD-011-0	No	Maintenance and Distribution of Steady-State Data Requirements and Reporting Procedures	0	0	0	0	0	0	0	0	1	0	1	0	0	0	0	0	0	0	0	0	0	1	
Pending Regulatory Approval	MOD-013-1	No	Maintenance and Distribution of Dynamics Data Requirements and Reporting Procedures	0	0	0	0	0	0	0	0	1	0	1	0	0	0	0	0	0	0	0	0	0	1	
Pending Regulatory Approval	MOD-014-0	No	Development of Steady-State System Models	0	0	0	0	0	0	0	0	1	0	1	0	0	0	0	0	0	0	0	0	0	1	
Pending Regulatory Approval	MOD-015-0	No	Development of Dynamics System Models	0	0	0	0	0	0	0	0	1	0	1	0	0	0	0	0	0	0	0	0	0	1	
Pending Regulatory Approval	MOD-031-1	No	Demand and Energy Data	0	0	0	0	0	0	0	0	1	0	1	0	0	0	0	0	0	0	0	0	0	1	
Pending Regulatory Approval	PRC-002-1	No	Define Regional Disturbance Monitoring and Reporting Requirements	0	0	0	0	0	0	0	0	1	0	1	0	0	0	0	0	0	0	0	0	0	1	
Pending Regulatory Approval	PRC-003-1	No	Regional Procedure for Analysis of Misoperations of Transmission and Generation Protection Systems	0	0	0	0	0	0	0	0	1	0	1	0	0	0	0	0	0	0	0	0	0	1	
Pending Regulatory Approval	PRC-004-3	Yes	Protection System Misoperation Identification and Correction	0	0	0	0	0	0	0	0	1	0	1	0	0	0	0	0	0	0	0	0	0	1	
Pending Regulatory Approval	PRC-005-3	Yes	Protection System and Automatic Reclosing Maintenance	0	0	0	0	0	0	0	0	1	0	1	0	0	0	0	0	0	0	0	0	0	1	
Pending Regulatory Approval	PRC-012-0	No	Special Protection System Review Procedure	0	0	0	0	0	0	0	0	1	0	1	0	0	0	0	0	0	0	0	0	0	1	
Pending Regulatory Approval	PRC-013-0	No	Special Protection System Database	0	0	0	0	0	0	0	0	1	0	1	0	0	0	0	0	0	0	0	0	0	1	
Pending Regulatory Approval	PRC-014-0	No	Special Protection System Assessment	0	0	0	0	0	0	0	0	1	0	1	0	0	0	0	0	0	0	0	0	0	1	
Pending Regulatory Approval	PRC-020-1	No	Under-Voltage Load Shedding Program Database	0	0	0	0	0	0	0	0	1	0	1	0	0	0	0	0	0	0	0	0	0	1	
Pending Regulatory Approval	TOP-006-3	Yes	Monitoring System Conditions	0	0	0	0	0	0	0	0	1	0	1	0	0	0	0	0	0	0	0	0	0	1	
Pending Regulatory Approval	TPL-001-3	No	System Performance Under Normal (No Contingency) Conditions (Category A)	0	0	0	0	0	0	0	0	1	0	1	0	0	0	0	0	0	0	0	0	0	1	
Pending Regulatory Approval	TPL-002-2b	No	System Performance Following Loss of a Single Bulk Electric System Element (Category B)	0	0	0	0	0	0	0	0	1	0	1	0	0	0	0	0	0	0	0	0	0	1	
Pending Regulatory Approval	TPL-003-2a	No	System Performance Following Loss of Two or More Bulk Electric System Elements (Category C)	0	0	0	0	0	0	0	0	1	0	1	0	0	0	0	0	0	0	0	0	0	1	
Pending Regulatory Approval	TPL-004-2	No	System Performance Following Extreme Events Resulting in the Loss of Two or More Bulk Electric System Elements (Category D)	0	0	0	0	0	0	0	0	1	0	1	0	0	0	0	0	0	0	0	0	0	1	
Pending Regulatory Approval	TPL-005-0	No	Regional and Interregional Self-Assessment Reliability Reports	0	0	0	0	0	0	0	0	1	0	1	0	0	0	0	0	0	0	0	0	0	1	
Pending Regulatory Filing	CIP-002-3b	No	Cyber Security — Critical Cyber Asset Identification	0	0	0	0	0	0	0	0	0	0	0	1	0	1	0	0	0	0	0	0	0	1	
Pending Regulatory Filing	CIP-003-3a	No	Cyber Security — Security Management Controls	0	0	0	0	0	0	0	0	0	0	0	1	0	1	0	0	0	0	0	0	0	1	
Pending Regulatory Filing	CIP-007-3b	No	Cyber Security — Systems Security Management	0	0	0	0	0	0	0	0	0	0	0	1	0	1	0	0	0	0	0	0	0	1	
Pending Regulatory Filing	COM-002-2a	No	Communications and Coordination	0	0	0	0	0	0	0	0	0	0	0	1	0	1	0	0	0	0	0	0	0	1	
Pending Regulatory Filing	IRO-001-4	No		0	0	0	0	0	0	0	0	0	0	0	1	0	1	0	0	0	0	0	0	0	1	
Pending Regulatory Filing	IRO-002-4	No		0	0	0	0	0	0	0	0	0	0	0	1	0	1	0	0	0	0	0	0	0	1	
Pending Regulatory Filing	IRO-008-2	No		0	0	0	0	0	0	0	0	0	0	0	1	0	1	0	0	0	0	0	0	0	1	
Pending Regulatory Filing	IRO-010-2	No		0	0	0	0	0	0	0	0	0	0	0	1	0	1	0	0	0	0	0	0	0	1	
Pending Regulatory Filing	IRO-014-3	No		0	0	0	0	0	0	0	0	0	0	0	1	0	1	0	0	0	0	0	0	0	1	
Pending Regulatory Filing	IRO-017-1	No		0	0	0	0	0	0	0	0	0	0	0	1	0	1	0	0	0	0	0	0	0	1	
Pending Regulatory Filing	TOP-002-4	Yes		0	0	0	0	0	0	0	0	0	0	0	1	0	1	0	0	0	0	0	0	0	1	
Pending Regulatory Filing	TOP-003-3	Yes		0	0	0	0	0	0	0	0	0	0	0	1	0	1	0	0	0	0	0	0	0	1	
*See Project 2014-03	IRO-001-3	Yes	Reliability Coordination — Responsibilities and Authorities	0	0	0	0	0	0	0	0	0	0	0	0	0	0	1	0	1	0	0	0	0	1	
*See Project 2014-03	IRO-002-3	No	Reliability Coordination — Analysis Tools	0	0	0	0	0	0	0	0	0	0	0	0	0	0	1	0	1	0	0	0	0	1	
*See Project 2014-03	IRO-005-4	Yes	Reliability Coordination — Current Day Operations	0	0	0	0	0	0	0	0	0	0	0	0	0	0	1	0	1	0	0	0	0	1	
*See Project 2014-03	IRO-014-2	No	Coordination Among Reliability Coordinators	0	0	0	0	0	0	0	0	0	0	0	0	0	0	1	0	1	0	0	0	0	1	
*See Project 2014-03	PRC-001-2	Yes	System Protection Coordination	0	0	0	0	0	0	0	0	0	0	0	0	0	0	1	0	1	0	0	0	0	1	
*See Project 2014-03	TOP-001-2	Yes	Transmission Operations	0	0	0	0	0	0	0	0	0	0	0	0	0	0	1	0	1	0	0	0	0	1	
*See Project 2014-03	TOP-002-3	Yes	Operations Planning	0	0	0	0	0	0	0	0	0	0	0	0	0	0	1	0	1	0	0	0	0	1	
*See Project 2014-03	TOP-003-2	Yes	Operational Reliability Data	0	0	0	0	0	0	0	0	0	0	0	0	0	0	1	0	1	0	0	0	0	1	
Designated for Retirement	MOD-024-1	No	Verification of Generator Gross and Net Real Power Capability	0	0	0	0	0	0	0	0	0	0	0	0	0	0	0	0	0	1	0	1	0	1	
Designated for Retirement	MOD-025-1	No	Verification of Generator Gross and Net Reactive Power Capability	0	0	0	0	0	0	0	0	0	0	0	0	0	0	0	0	0	1	0	1	0	1	
				98	14			24	1			24	0			12	0			8	0			2	0	183

These values populate the summary table.

Note:
Verify/complete yellow cells. Ensure rest aligns with the paper. Delete rows not needed.

Priority	Status	Standard	Applicability Section	Reg	Title	ste	reg	te	no	re	ste	reg	te	no	ris	fte	reg	pra	reg	ra	no	re	pra	reg	prf	reg	prf	no	reg	prf	reg	rem	reg	em	no	re	rem	reg	ret	reg	et	no	re	ret	reg	total					
High	Subject to Enforcement	PRC-004-2.1a	Applicability Section	Misoperations affecting >75MVA	Analysis and Mitigation of Transmission and Generation Protection System Misoperations	1	0	1	0	0	0	0	0	0	0	0	0	0	0	0	0	0	0	0	0	0	0	0	0	0	0	0	0	0	0	0	0	0	0	0	0	0	0	0	0	0	1				
High	Pending Regulatory Approval	PRC-004-3	Applicability Section	Misoperations affecting >75MVA	Protection System Misoperation Identification and Correction	0	0	0	0	0	0	0	0	0	1	0	0	0	0	1	0	0	0	0	0	0	0	0	0	0	0	0	0	0	0	0	0	0	0	0	0	0	0	0	0	0	0	0	1		
High	Subject to Enforcement	PRC-005-1.1b	Guidance	Point where aggregates to >75MVA	Transmission and Generation Protection System Maintenance and Testing	1	0	1	0	0	0	0	0	0	0	0	0	0	0	0	0	0	0	0	0	0	0	0	0	0	0	0	0	0	0	0	0	0	0	0	0	0	0	0	0	0	0	1			
High	Subject to Future Enforcement	PRC-005-2	Applicability Section	Point where aggregates to >75MVA	Protection System Maintenance	0	0	0	0	1	0	0	0	0	0	0	0	0	0	0	0	0	0	0	0	0	0	0	0	0	0	0	0	0	0	0	0	0	0	0	0	0	0	0	0	0	0	1			
High	Pending Regulatory Approval	PRC-005-3	Applicability Section	Point where aggregates to >75MVA	Protection System and Automatic Reclosing Maintenance	0	0	0	0	0	0	0	0	0	1	0	0	0	0	1	0	0	0	0	0	0	0	0	0	0	0	0	0	0	0	0	0	0	0	0	0	0	0	0	0	0	0	0	1		
High	Subject to Enforcement	VAR-002-3	Applicability Section & Footnote	Aggregate Facility Level for Voltage Control; Transmission voltage GSUs	Generator Operation for Maintaining Network Voltage Schedules	1	0	1	0	0	0	0	0	0	0	0	0	0	0	0	0	0	0	0	0	0	0	0	0	0	0	0	0	0	0	0	0	0	0	0	0	0	0	0	0	0	0	0	1		
Medium	Subject to Enforcement	EOP-004-2	No Action	NA	Event Reporting	1	0	1	0	0	0	0	0	0	0	0	0	0	0	0	0	0	0	0	0	0	0	0	0	0	0	0	0	0	0	0	0	0	0	0	0	0	0	0	0	0	0	0	1		
Medium	Subject to Enforcement	FAC-008-3	Guidance	Individual BES Resources /Elements to Include Aggregating Equipment	Facility Ratings	1	0	1	0	0	0	0	0	0	0	0	0	0	0	0	0	0	0	0	0	0	0	0	0	0	0	0	0	0	0	0	0	0	0	0	0	0	0	0	0	0	0	1			
Medium	Pending Regulatory Filing	IRO-017-1	TBD	TBD		0	0	0	0	0	0	0	0	0	0	0	0	0	0	0	0	1	0	1	0	0	0	0	0	0	0	0	0	0	0	0	0	0	0	0	0	0	0	0	0	0	0	1			
Medium	Subject to Future Enforcement	MOD-025-2	No Action	NA	Verification and Data Reporting of Generator Real and Reactive Power Capability and Synchronous Condenser Reactive Power Capability	0	0	0	0	1	0	0	0	0	0	0	0	0	0	0	0	0	0	0	0	0	0	0	0	0	0	0	0	0	0	0	0	0	0	0	0	0	0	0	0	0	0	0	1		
Medium	Subject to Enforcement	MOD-026-1	No Action	NA	Verification of Models and Data for Generator Excitation Control System or Plant Volt/Var Control Functions	1	0	1	0	0	0	0	0	0	0	0	0	0	0	0	0	0	0	0	0	0	0	0	0	0	0	0	0	0	0	0	0	0	0	0	0	0	0	0	0	0	0	0	0	1	
Medium	Subject to Enforcement	MOD-027-1	No Action	NA	Verification of Models and Data for Turbine/Governor and Load Control or Active Power/Frequency Control Functions	1	0	1	0	0	0	0	0	0	0	0	0	0	0	0	0	0	0	0	0	0	0	0	0	0	0	0	0	0	0	0	0	0	0	0	0	0	0	0	0	0	0	0	0	1	
Medium	Subject to Future Enforcement	MOD-032-1	No Action	NA	Data for Power System Modeling and Analysis	0	0	0	0	1	0	0	0	0	0	0	0	0	0	0	0	0	0	0	0	0	0	0	0	0	0	0	0	0	0	0	0	0	0	0	0	0	0	0	0	0	0	0	0	1	
Medium	Subject to Enforcement	PRC-001-1.1	Applicability Section	Aggregate Facility Level	System Protection Coordination	1	0	1	0	0	0	0	0	0	0	0	0	0	0	0	0	0	0	0	0	0	0	0	0	0	0	0	0	0	0	0	0	0	0	0	0	0	0	0	0	0	0	0	1		
Medium	Subject to Future Enforcement	PRC-019-1	Applicability Section	Individual BES Resources/Elements	Coordination of Generating Unit or Plant Capabilities, Voltage Regulating Controls, and Protection	0	0	0	0	1	0	0	0	0	0	0	0	0	0	0	0	0	0	0	0	0	0	0	0	0	0	0	0	0	0	0	0	0	0	0	0	0	0	0	0	0	0	0	0	1	
Medium	Subject to Future Enforcement	PRC-024-1	By Requirement	Individual BES Resources /Elements to Include Aggregating Equipment	Generator Frequency and Voltage Protective Relay Settings	0	0	0	0	1	0	0	0	0	0	0	0	0	0	0	0	0	0	0	0	0	0	0	0	0	0	0	0	0	0	0	0	0	0	0	0	0	0	0	0	0	0	0	0	1	
Medium	Subject to Enforcement	PRC-025-1	Guidance	Individual BES Resources /Elements to Include Aggregating Equipment	Generator Relay Loadability	1	0	1	0	0	0	0	0	0	0	0	0	0	0	0	0	0	0	0	0	0	0	0	0	0	0	0	0	0	0	0	0	0	0	0	0	0	0	0	0	0	0	0	0	1	
Medium	Subject to Enforcement	TOP-001-1a	No Action	NA	Reliability Responsibilities and Authorities	1	0	1	0	0	0	0	0	0	0	0	0	0	0	0	0	0	0	0	0	0	0	0	0	0	0	0	0	0	0	0	0	0	0	0	0	0	0	0	0	0	0	0	0	0	1
Medium	Subject to Enforcement	TOP-002-2.1b	Applicability Section	Aggregate Facility Level	Normal Operations Planning	1	0	1	0	0	0	0	0	0	0	0	0	0	0	0	0	0	0	0	0	0	0	0	0	0	0	0	0	0	0	0	0	0	0	0	0	0	0	0	0	0	0	0	0	1	
Medium	Pending Regulatory Filing	TOP-002-4	TBD	TBD		0	0	0	0	0	0	0	0	0	0	0	0	0	0	0	0	1	0	1	0	0	0	0	0	0	0	0	0	0	0	0	0	0	0	0	0	0	0	0	0	0	0	0	0	1	
Medium	Subject to Enforcement	TOP-003-1	By Requirement	Aggregate Facility Level	Planned Outage Coordination	1	0	1	0	0	0	0	0	0	0	0	0	0	0	0	0	0	0	0	0	0	0	0	0	0	0	0	0	0	0	0	0	0	0	0	0	0	0	0	0	0	0	0	0	0	1
Medium	Pending Regulatory Filing	TOP-003-3	TBD	TBD		0	0	0	0	0	0	0	0	0	0	0	0	0	0	0	0	1	0	1	0	0	0	0	0	0	0	0	0	0	0	0	0	0	0	0	0	0	0	0	0	0	0	0	0	1	
Medium	Subject to Enforcement	TOP-006-2	No Action	NA	Monitoring System Conditions	1	0	1	0	0	0	0	0	0	0	0	0	0	0	0	0	0	0	0	0	0	0	0	0	0	0	0	0	0	0	0	0	0	0	0	0	0	0	0	0	0	0	0	0	0	1
Medium	Pending Regulatory Approval	TOP-006-3	TBD	TBD	Monitoring System Conditions	0	0	0	0	0	0	0	0	1	0	0	0	0	0	0	0	0	0	0	0	0	0	0	0	0	0	0	0	0	0	0	0	0	0	0	0	0	0	0	0	0	0	0	0	0	1
Low	Subject to Enforcement	BAL-001-TRE-1	Applicability Section	Aggregate Facility Level	R Primary Frequency Response in the ERCOT Region	1	1	0	1	0	1	0	0	0	1	0	0	0	1	0	0	0	1	0	0	0	0	0	1	0	0	0	1	0	0	0	0	0	1	0	0	0	0	0	0	0	0	0	0	1	
Low	Subject to Enforcement	PRC-004-WECC-1	Applicability Section	Point where aggregates to >75MVA	R Protection System and Remedial Action Scheme Misoperation	1	1	0	1	0	1	0	0	0	1	0	0	0	1	0	0	0	1	0	0	0	0	1	0	0	0	1	0	0	0	0	0	1	0	0	0	0	0	0	0	0	0	0	0	1	
Low	Subject to Future Enforcement	PRC-006-NPCC-1	By Requirement	Individual BES Resources/Elements	R Automatic Underfrequency Load Shedding	0	1	0	0	1	1	0	1	0	1	0	0	0	1	0	0	0	0	1	0	0	0	1	0	0	0	1	0	0	0	1	0	0	0	0	1	0	0	0	0	0	0	0	0	0	1
Low	Subject to Enforcement	PRC-006-SERC-01	By Requirement	Individual BES Resources/Elements	R Automatic Underfrequency Load Shedding Requirements	1	1	0	1	0	1	0	0	0	1	0	0	0	1	0	0	0	0	1	0	0	0	1	0	0	0	1	0	0	0	0	1	0	0	0	0	0	0	0	0	0	0	0	0	0	1
						13								5																																28					

Note: Verify/complete yellow cells.
Ensure rest aligns with the paper.
Delete rows not needed.

These values populate the summary table.

Exhibit E

Supplementary Reference and FAQ

NERC

NORTH AMERICAN ELECTRIC
RELIABILITY CORPORATION

Supplementary Reference and FAQ

PRC-005-6 Protection System, Automatic
Reclosing, and Sudden Pressure Relaying
Maintenance and Testing

October 2015

RELIABILITY | ACCOUNTABILITY



3353 Peachtree Road NE
Suite 600, North Tower
Atlanta, GA 30326
404-446-2560 | www.nerc.com

Table of Contents

Table of Contents.....	ii
1. Introduction and Summary.....	1
2. Need for Verifying Protection System Performance	3
2.1 Existing NERC Standards for Protection System Maintenance and Testing	3
2.2 Protection System Definition	4
2.3 Applicability of New Protection System Maintenance Standards	4
2.3.1 Frequently Asked Questions:	5
2.4.1 Frequently Asked Questions:	7
3. Protection System and Automatic Reclosing Product Generations	14
4. Definitions.....	16
4.1 Frequently Asked Questions:	17
5. Time-Based Maintenance (TBM) Programs.....	19
5.1 Maintenance Practices.....	19
5.1.1 Frequently Asked Questions:	21
5.2 Extending Time-Based Maintenance	22
5.2.1 Frequently Asked Questions:	23
6. Condition-Based Maintenance (CBM) Programs.....	24
6.1 Frequently Asked Questions:	24
7. Time-Based Versus Condition-Based Maintenance.....	26
7.1 Frequently Asked Questions:	26
8. Maximum Allowable Verification Intervals.....	32
8.1 Maintenance Tests.....	32
8.1.1 Table of Maximum Allowable Verification Intervals.....	32

8.1.2 Additional Notes for Tables 1-1 through 1-5, Table 3, and Table 4.....	34
8.1.3 Frequently Asked Questions:	35
8.2 Retention of Records.....	40
8.2.1 Frequently Asked Questions:	41
8.3 Basis for Table 1 Intervals	43
8.4 Basis for Extended Maintenance Intervals for Microprocessor Relays	44
9. Performance-Based Maintenance Process.....	47
9.1 Minimum Sample Size.....	48
9.2 Frequently Asked Questions:	51
10. Overlapping the Verification of Sections of the Protection System.....	62
10.1 Frequently Asked Questions:	62
11. Monitoring by Analysis of Fault Records	63
11.1 Frequently Asked Questions:	64
12. Importance of Relay Settings in Maintenance Programs	65
12.1 Frequently Asked Questions:	65
13. Self-Monitoring Capabilities and Limitations.....	68
13.1 Frequently Asked Questions:	69
14. Notification of Protection System or Automatic Reclosing Failures.....	70
15. Maintenance Activities	71
15.1 Protective Relays (Table 1-1)	71
15.1.1 Frequently Asked Questions:	71
15.2 Voltage & Current Sensing Devices (Table 1-3)	71
15.2.1 Frequently Asked Questions:	73
15.3 Control circuitry associated with protective functions (Table 1-5)	74
15.3.1 Frequently Asked Questions:	75

15.4 Batteries and DC Supplies (Table 1-4).....	77
15.4.1 Frequently Asked Questions:	78
15.5 Associated communications equipment (Table 1-2)	92
15.5.1 Frequently Asked Questions:	93
15.6 Alarms (Table 2)	96
15.6.1 Frequently Asked Questions:	97
15.7 Distributed UFLS and Distributed UVLS Systems (Table 3).....	97
15.7.1 Frequently Asked Questions:	98
15.8 Automatic Reclosing (Table 4)	98
15.8.1 Frequently-asked Questions	98
15.9 Examples of Evidence of Compliance	101
15.9.1 Frequently Asked Questions:	103
References	104
Figures.....	106
Figure 1: Typical Transmission System.....	106
Figure 2: Typical Generation System	107
Figure 1 & 2 Legend – Components of Protection Systems	108
Appendix A.....	109
Appendix B	112
Protection System Maintenance Standard Drafting Team.....	112

1. Introduction and Summary

Note: This supplementary reference for PRC-005-6 is neither mandatory nor enforceable.

NERC currently has four Reliability Standards that are mandatory and enforceable within the jurisdiction of the ERO and address various aspects of maintenance and testing of Protection and Control Systems.

These standards are:

PRC-005-1.1b — Transmission and Generation Protection System Maintenance and Testing

PRC-008-0 — Underfrequency Load Shedding Equipment Maintenance Programs

PRC-011-0 — UVLS System Maintenance and Testing

PRC-017-0 — Special Protection System Maintenance and Testing

While these standards require that applicable entities have a maintenance program for Protection Systems, and that these entities must be able to demonstrate they are carrying out such a program, there are no specifics regarding the technical requirements for Protection System maintenance programs. Furthermore, FERC Order 693¹ directed additional modifications to the respective Protection System maintenance programs. PRC-005-3 will replace PRC-005-2 which combined and replaced PRC-005, PRC-008, PRC-011 and PRC-017. PRC-005-3 adds Automatic Reclosing to PRC-005-2. PRC-005-2 addressed these directed modifications and replaces PRC-005, PRC-008, PRC-011 and PRC-017.

FERC Order 758² further directed that maintenance of reclosing relays and sudden pressure relays that affect the reliable operation of the Bulk Power System be addressed. PRC-005-3 addresses this directive regarding reclosing relays, and, when approved, will supersede PRC-005-2. PRC-005-4 addresses this directive regarding sudden pressure relays and, when approved, will supersede PRC-005-3.

This document augments the Supplementary Reference and FAQ previously developed for PRC-005-4 by including discussions relevant to the following standard revisions:

- PRC-005-3 – add Automatic Reclosing in accordance with directives in FERC Order 758 as supported by the technical reports of the System Protection Control Subcommittee and the System Analysis and Modeling Subcommittee

¹ *Mandatory Reliability Standards for the Bulk-Power System*, Order No. 693, 118 FERC ¶ 61,218, FERC Stats. & Regs. ¶ 31,242 (“Order No. 693”), *order on reh’g*, *Mandatory Reliability Standards for the Bulk-Power System*, 120 FERC ¶ 61,053 (Order No. 693-A) (2007).

² *Interpretation of Protection System Reliability Standard*, Order No. 758, 138 FERC ¶ 61,094 (2012) (“Order No. 758”).

-
- PRC-005-4 – add Sudden Pressure Relaying in accordance with directives in FERC Order 758 as supported by the technical report of the System Protection Control Subcommittee
 - PRC-005-5 – update Applicability requirements for dispersed generation resources to align with revisions to the definition of the Bulk Electric System
 - PRC-005-6 – add supervisory relays to Automatic Reclosing in accordance with directives in FERC Order 803³.

³ *Protection System Maintenance Reliability Standard*, Order No. 803, 150 FERC ¶ 61,039 (2015) (“Order No. 803”).

2. Need for Verifying Protection System Performance

Protective relays have been described as silent sentinels, and do not generally demonstrate their performance until a Fault or other power system problem requires that they operate to protect power system Elements, or even the entire Bulk Electric System (BES). Lacking Faults, switching operations or system problems, the Protection Systems may not operate, beyond static operation, for extended periods. A Misoperation— defined as --a false operation of a Protection System or a failure of the Protection System to operate, as designed, when needed--can result in equipment damage, personnel hazards, and wide-area Disturbances or unnecessary customer outages. Maintenance or testing programs are used to determine the performance and availability of Protection Systems.

Typically, utilities have tested Protection Systems at fixed time intervals, unless they had some incidental evidence that a particular Protection System was not behaving as expected. Testing practices vary widely across the industry. Testing has included system functionality, calibration of measuring devices, and correctness of settings. Typically, a Protection System must be visited at its installation site and, in many cases, removed from service for this testing.

Fundamentally, a Reliability Standard for Protection System Maintenance and Testing requires the performance of the maintenance activities that are necessary to detect and correct plausible age and service related degradation of the Protection System components, such that a properly built and commissioned Protection System will continue to function as designed over its service life.

Similarly station batteries, which are an important part of the station dc supply, are not called upon to provide instantaneous dc power to the Protection System until power is required by the Protection System to operate circuit breakers or interrupting devices to clear Faults or to isolate equipment.

2.1 Existing NERC Standards for Protection System Maintenance and Testing

For critical BES protection functions, NERC standards have required that each utility or asset owner define a testing program. The starting point is the Board approved Standard PRC-005-5, briefly restated as follows:

Purpose: To document and implement programs for the maintenance of all Protection Systems affecting the reliability of the Bulk Electric System (BES) so that these Protection Systems are kept in working order.

PRC-005-6 is not specific on where the boundaries of the Protection Systems lie. However, the definition of Protection System in the [Glossary of Terms](#) Used in NERC Reliability Standards (Glossary) indicates what must be included as a minimum.

At the beginning of the project to develop PRC-005-2, the definition of Protection System was:

Protective relays, associated communications Systems, voltage and current sensing devices, station batteries and dc control circuitry.

Applicability: Owners of generation and transmission Protection Systems.

Requirements: The owner shall have a documented maintenance program with test intervals. The owner must keep records showing that the maintenance was performed at the specified intervals.

2.2 Protection System Definition

The most recently approved definition of Protection Systems is:

- Protective relays which respond to electrical quantities,
- Communications systems necessary for correct operation of protective functions,
- Voltage and current sensing devices providing inputs to protective relays,
- Station dc supply associated with protective functions (including station batteries, battery chargers, and non-battery-based dc supply), and
- Control circuitry associated with protective functions through the trip coil(s) of the circuit breakers or other interrupting devices.

2.3 Applicability of New Protection System Maintenance Standards

The BES purpose is to transfer bulk power. The applicability language has been changed from the original PRC-005:

“...affecting the reliability of the Bulk Electric System (BES)...”

To the present language:

“...that are installed for the purpose of detecting Faults on BES Elements (lines, buses, transformers, etc.).”

The drafting team intends that this standard will be consistent with any future definition of the Bulk Electric System. There should be no ambiguity; if the Element is a BES Element, then the Protection System protecting that Element should then be included within this standard. If there is regional variation to the definition, then there will be a corresponding regional variation to the Protection Systems that fall under this standard.

There is no way for the Standard Drafting Team to know whether a specific 230KV line, 115KV line (even 69KV line), for example, should be included or excluded. Therefore, the team expressed the clear intent that the standard language should simply be applicable to Protection Systems for BES Elements.

The BES is a NERC defined term that, from time to time, may undergo revisions. Additionally, there may be regional variations that are allowed in the present and future definitions.⁴ Refer to the applicable Regional Reliability Organization for any applicable allowed variations.

While this standard may undergo revisions in the future, this standard will not attempt to keep up with revisions to the NERC definition of BES, but, rather, simply make BES Protection Systems applicable.

The Standard is applied to Generator Owners (GO) and Transmission Owners (TO) because GOs and TOs have BES equipment. The standard brings in Distribution Providers (DP) because,

⁴ See the NERC Glossary of Terms for the present, in-force definition.

depending on the station configuration of a particular substation, there may be Protection System equipment installed at a non-transmission voltage level (Distribution Provider equipment) that is wholly or partially installed to protect the BES. PRC-005-2 would apply to this equipment. An example is underfrequency load-shedding, which is frequently applied in distribution systems to meet PRC-007-0.

PRC-005-2 replaced the existing PRC-005, PRC-008, PRC-011 and PRC-017. Much of the original language of those standards was carried forward whenever it was possible to continue the intent and avoid a conflict with FERC Order 693. For example, the original PRC-008 was constructed quite differently than the original PRC-005. The drafting team agrees with the intent of this and notes that distributed tripping schemes would have to exhibit multiple failures to trip before they would prove to be significant, as opposed to a single failure to trip of, for example, a transmission Protection System Bus Differential lock-out relay. While a substantial number of failures of these distribution breakers could be significant, the team concluded likely that distribution breakers are operated often only for Fault clearing duty; and, therefore, the distribution circuit breakers are operated at least as frequently as stipulated in any requirement in this standard.

Additionally, since PRC-005-2 replaced PRC-011, it will be important to distinguish between under-voltage Protection Systems that protect individual Loads and Protection Systems that are Undervoltage Load Shedding (UVLS) schemes that protect the BES. Any UVLS scheme that had been applicable under PRC-011 is now applicable under PRC-005-2. An example of an under-voltage load-shedding scheme that is not applicable to this standard is one in which the tripping action was intended to prevent low distribution voltage to a specific Load from a Transmission system that was intact except for the line that was out of service, as opposed to preventing a Cascading outage or Transmission system collapse.

It had been correctly noted that the devices needed for PRC-011 are the very same types of devices needed in PRC-005.

Thus, a standard written for Protection Systems of the BES can easily make the needed requirements for Protection Systems, and replace some other standards at the same time.

2.3.1 Frequently Asked Questions:

What exactly is the BES, or Bulk Electric System?

BES is the abbreviation for the defined term Bulk Electric System. BES is a term in the Glossary of Terms used in Reliability Standards, and is not being modified within this draft standard.

Why is Distribution Provider included within the Applicable Entities and as a responsible entity within several of the requirements? Wouldn't anyone having relevant Facilities be a Transmission Owner?

Depending on the station configuration of a particular substation, there may be Protection System equipment installed at a non-transmission voltage level (Distribution Provider equipment) that is wholly or partially installed to protect the BES. PRC-005-2 applies to this equipment. An example is underfrequency load-shedding, which is frequently applied well down into the distribution system to meet the requirements of PRC-007-0.

We have an under voltage load-shedding (UVLS) system in place that prevents one of our distribution substations from supplying extremely low voltage in the case of a specific transmission line outage. The transmission line is part of the BES. Does this mean that our UVLS system falls within this standard?

The situation, as stated, indicates that the tripping action was intended to prevent low distribution voltage to a specific Load from a Transmission System that was intact, except for the line that was out of service, as opposed to preventing Cascading outage or Transmission System Collapse. This standard is not applicable to this UVLS.

We have a UFLS or UVLS scheme that sheds the necessary Load through distribution-side circuit breakers and circuit reclosers. Do the trip-test requirements for circuit breakers apply to our situation?

No--Distributed tripping schemes would have to exhibit multiple failures to trip before they would prove to be significant, as opposed to a single failure to trip of, for example, a transmission Protection System bus differential lock-out relay. While many failures of these distribution breakers could add up to be significant, it is also believed that distribution breakers are operated often on just Fault clearing duty; and, therefore, the distribution circuit breakers are operated at least as frequently as any requirements that might have appeared in this standard.

We have a UFLS scheme that, in some locales, sheds the necessary Load through non-BES circuit breakers and, occasionally, even circuit switchers. Do the trip-test requirements for circuit breakers apply to our situation?

If your “non-BES circuit breaker” has been brought into this standard by the inclusion of UFLS requirements, and otherwise would not have been brought into this standard, then the answer is that there are no trip-test requirements. For these devices that are otherwise non-BES assets, these tripping schemes would have to exhibit multiple failures to trip before they would prove to be as significant as, for example, a single failure to trip of a transmission Protection System bus differential lock-out relay.

How does the “Facilities” section of “Applicability” track with the standards that will be retired once PRC-005-2 becomes effective?

In establishing PRC-005-2, the drafting team combined legacy standards PRC-005-1b, PRC-008-0, PRC-011-0, and PRC-017-0. The merger of the subject matter of these standards is reflected in Applicability 4.2.

The intent of the drafting team is that the legacy standards be reflected in PRC-005-2 as follows:

- Applicability of PRC-005-1.1b for Protection Systems relating to non-generator elements of the BES is addressed in 4.2.1.
- Applicability of PRC-008-0 for underfrequency load shedding systems is addressed in 4.2.2.
- Applicability of PRC-011-0 for undervoltage load shedding relays is addressed in 4.2.3.
- Applicability of PRC-017-0 for Remedial Action Schemes is addressed in 4.2.4.
- Applicability of PRC-005-1.1b for Protection Systems for BES generators is addressed in 4.2.5 and 4.2.6.

2.4 Applicable Relays

The Glossary definition has a Protection System including relays, dc supply, current and voltage sensing devices, dc control circuitry and associated communications circuits. The relays to which this standard applies are those protective relays that respond to electrical quantities and provide a trip output to trip coils, dc control circuitry or associated communications equipment. This definition extends to IEEE Device No. 86 (lockout relay) and IEEE Device No. 94 (tripping or trip-free relay), as these devices are tripping relays that respond to the trip signal of the protective relay that processed the signals from the current and voltage-sensing devices.

Relays that respond to non-electrical inputs or impulses (such as, but not limited to, vibration, seismic, thermal or gas accumulation) are not included.

Automatic Reclosing is addressed in PRC-005-3 by explicitly addressing them outside the definition of Protection System. The specific locations for applicable Automatic Reclosing are addressed in Applicability Section 4.2.7.

Sudden Pressure Relaying is addressed in PRC-005-4 by explicitly addressing them outside the definition of Protection System. The specific locations for applicable Sudden Pressure Relaying are addressed in Applicability Section 4.2.1, 4.2.5.2, 4.2.5.3, and 4.2.6.

2.4.1 Frequently Asked Questions:

Are power circuit reclosers, reclosing relays, closing circuits and auto-restoration schemes covered in this Standard?

Yes. Automatic Reclosing includes reclosing relays and the associated dc control circuitry. Section 4.2.7 of the Applicability specifically limits the applicable reclosing relays to:

4.2.7 Automatic Reclosing

4.2.7.1 Automatic Reclosing applied on the terminals of Elements connected to the BES bus located at generating plant substations where the total installed gross generating plant capacity is greater than the gross capacity of the largest BES generating unit within the Balancing Authority Area or, if a member of a Reserve Sharing Group, the largest generating unit within the Reserve Sharing Group.

4.2.7.2 Automatic Reclosing applied on the terminals of all BES Elements at substations one bus away from generating plants specified in Section 4.2.7.1 when the substation is less than 10 circuit-miles from the generating plant substation.

4.2.7.3 Automatic Reclosing applied as an integral part of an RAS specified in Section 4.2.4.

Further, Footnote 1 to Applicability Section 4.2.7 establishes that Automatic Reclosing addressed in 4.2.7.1 and 4.2.7.2 may be excluded if the equipment owner can demonstrate that a close-in three-phase fault present for twice the normal clearing time (capturing a minimum trip-close-trip time delay) does not result in a total loss of gross generation in the Interconnection exceeding the gross capacity of the largest relevant BES generating unit where the Automatic Reclosing is applied.

Additionally, Footnote 2 to Applicability Section 4.2.7.1 advises that the entity's PSMP needs to remain current regarding the applicability of Automatic Reclosing Components relative to the largest generating unit within the Balancing Authority Area or Reserve Sharing Group.

The Applicability as detailed above was recommended by the NERC System Analysis and Modeling Subcommittee (SAMS) after a lengthy review of the use of reclosing within the BES. SAMS concluded that automatic reclosing is largely implemented throughout the BES as an operating convenience, and that automatic reclosing mal-performance affects BES reliability only when the reclosing is part of a Remedial Action Schemes, or when premature autoreclosing has the potential to cause generating unit or plant instability. A technical report, "Considerations for Maintenance and Testing of Autoreclosing Schemes — November 2012", is referenced in PRC-005-3 and provides a more detailed discussion of these concerns.

Why did the standard drafting team not include IEEE device numbers to describe Automatic Reclosing Relays?

The drafting team elected not to include IEEE device numbers to describe Automatic Reclosing because Automatic Reclosing component type could be a stand-alone electromechanical relay; or could be the 79 function within a microprocessor based multi-function relay.

Was it the drafting team's intent that the definition of Automatic Reclosing incorporate all closings that happen automatically, or just Automatic Reclosing relays?

The drafting team believes that Automatic Reclosing definition, as supported by the second part of the IEEE Standard 100 definition stating "Automatic reclosing equipment - Automatic equipment that provides for reclosing a switching device as desired after it has opened automatically under abnormal conditions..." adequately addresses this concern. Automatic Reclosing does not include actions such as automatic closing of the circuit breakers associated with shunt or series capacitor banks or shunt reactors.

What is synchronizing or synchronism check relay (Sync-Check - 25)?

A synchronizing device that produces an output that supervises closure of a circuit breaker between two circuits whose voltages are within prescribed limits of magnitude and within the prescribed phase angle for the prescribed time. It may or may not include voltage or speed control. A sync-check relay permits the paralleling of two circuits that are within prescribed (usually wider) limits of voltage magnitude and phase angle for the prescribed time.

How do I interpret Applicability Section 4.2.7 to determine applicability in the following examples:

At my generating plant substation, I have a total of 800 MW connected to one voltage level and 200 MW connected to another voltage level. How do I determine my gross capacity? Where do I consider Automatic Reclosing to be applicable?

Scenario number 1:

The 800 MW of generation is connected to a BES voltage level bus, the 200 MW is connected to a non-BES voltage level bus, and there is no connection between the two buses locally or within 10 circuit miles from the generating plant substation. The largest single unit in the BA area is 750 MW.

In this case, the total installed gross generating capacity would be 800 MW. The two units are essentially independent plants.

The BES voltage level bus is considered to be the bus to which the 800 MW of generation is connected. Any BES Automatic Reclosing at this location, as well as other locations within 10 circuit miles, is considered to be applicable because 800 MW exceeds the largest single unit in the BA area.

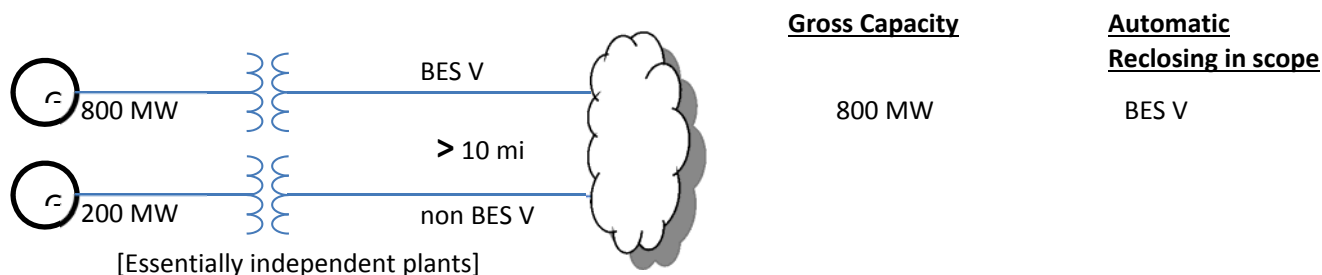

Scenario number 2:

The 800 MW of generation is connected to a BES voltage level bus, the 200 MW unit is connected to a non-BES voltage level bus, and there is a connection between the two buses locally or within 10 circuit miles from the generating plant substation. The largest single unit in the BA area is 750 MW.

In this case, reclosing into a fault on the BES system could impact the stability of the non-BES-connected generating units. Therefore, the total installed gross generating capacity would be 1000 MW.

The BES voltage level bus is considered to be the bus to which the 800 MW of generation is connected. Any BES Automatic Reclosing at this location, as well as other locations within 10 circuit miles, is considered to be applicable because total of 1000 MW exceeds the largest single unit in the BA area. However, the Automatic Reclosing on the non-BES voltage level bus is not applicable.

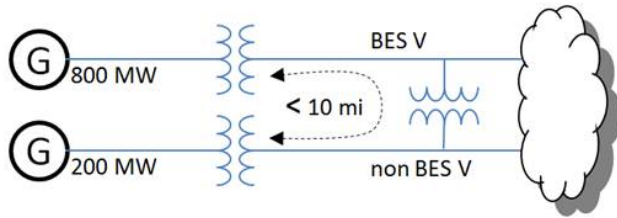

Gross Capacity

Automatic Reclosing in scope

1000 MW

BES V

Scenario number 3:

The 800 MW of generation is connected to a BES voltage level bus, the 200 MW unit is connected to a non-BES voltage level bus, and there is no connection between the two buses locally or within 10 circuit miles from the generating plant substation but the generating units connected at the BES voltage level do not operate independently of the units connected at the non BES voltage level (e.g., a combined cycle facility where 800 MW of combustion turbines are connected at a BES voltage level whose exhaust is used to power a 200 MW steam unit connected to a non BES voltage level. The largest single unit in the BA area is 750 MW.

In this case, the total installed gross generating capacity would be 1000 MW. Therefore, reclosing into a fault on the BES voltage level would result in a loss of the 800 MW combustion turbines and subsequently result in the loss of the 200 MW steam unit because of the loss of the heat source to its boiler.

The BES voltage level bus is considered to be the bus to which the 800 MW of generation is connected. Any BES Automatic Reclosing at this location, as well as other locations within 10 circuit miles, is considered to be applicable because total of 1000 MW exceeds the largest single unit in the BA area. However, the Automatic Reclosing on the non-BES voltage level bus is not applicable.

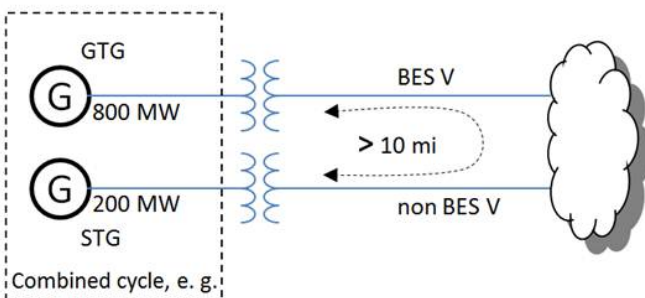

Gross Capacity

Automatic Reclosing in scope

1000 MW

BES V

Scenario 4

The 800 MW of generation is connected at 345 kV and the 200 MW is connected at 138 kV with an autotransformer at the generating plant substation connecting the two voltage levels. The largest single unit in the BA area is 900 MW.

In this case, the total installed gross generating capacity would be 1000 MW and section 4.2.7.1 would be applicable to both the 345 kV Automatic Reclosing Components and the 138 kV

Automatic Reclosing Components, since the total capacity of 1000 MW is larger than the largest single unit in the BA area.

However, if the 345 kV and the 138 kV systems can be shown to be uncoupled such that the 138 kV reclosing relays will not affect the stability of the 345 kV generating units then the 138 kV Automatic Reclosing Components need not be included per section 4.2.7.1.

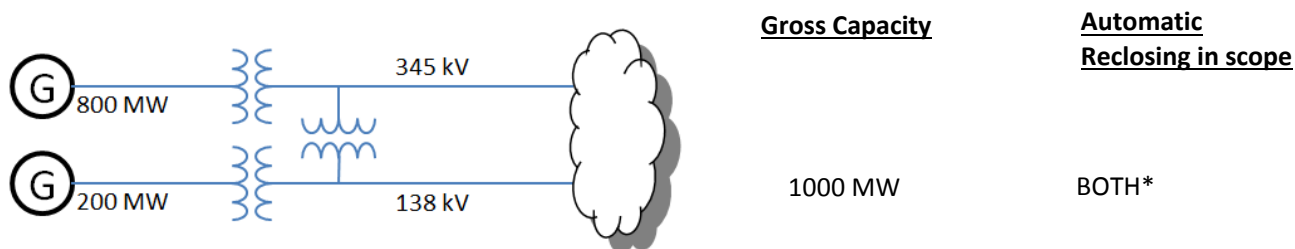

* The study detailed in Footnote 1 of the draft standard may eliminate the 138 kV Automatic Reclosing Components and/or the 345 kV Automatic Reclosing Components

Why does 4.2.7.2 specify “10 circuit miles”?

As noted in “Considerations for Maintenance and Testing of Autoreclosing Schemes — November 2012,” transmission line impedance on the order of one mile away typically provides adequate impedance to prevent generating unit instability and a 10 mile threshold provides sufficient margin.

Should I use MVA or MW when determining the installed gross generating plant capacity?

Be consistent with the rating used by the Balancing Authority for the largest BES generating unit within their area.

What value should we use for generating plant capacity in 4.2.7.1?

Use the value reported to the Balance Authority for generating plant capacity for planning and modeling purposes. This can be nameplate or other values based on generating plant limitations such as boiler or turbine ratings.

What is considered to be “one bus away” from the generation?

The BES voltage level bus is considered to be the generating plant substation bus to which the generator step-up transformer is connected. “One bus away” is the next bus, connected by either a transmission line or transformer.

I use my protective relays only as sources of metered quantities and breaker status for SCADA and EMS through a substation distributed RTU or data concentrator to the control center. What are the maintenance requirements for the relays?

This standard addresses Protection Systems that are installed for the purpose of detecting Faults on BES Elements (e.g. lines, buses, transformers, etc.). Protective relays, providing only the functions mentioned in the question, are not included.

Are Reverse Power Relays installed on the low-voltage side of distribution banks considered to be components of “Protection Systems that are installed for the purpose of detecting Faults on BES Elements (i.e.lines, buses, transformers, etc.)?”

Reverse power relays are often installed to detect situations where the transmission source becomes de-energized and the distribution bank remains energized from a source on the low-voltage side of the transformer and the settings are calculated based on the charging current of the transformer from the low-voltage side. Although these relays may operate as a result of a fault on a BES element, they are not “installed for the purpose of detecting” these faults.

Why is the maintenance of Sudden Pressure Relaying being addressed in PRC-005-6?

Proper performance of Sudden Pressure Relaying supports the reliability of the BES because fault pressure relays can detect rapid changes in gas pressure, oil pressure, or oil flow that are indicative of faults within liquid-filled, wire-wound equipment such as turn-to-turn faults which may be undetected by Protection Systems. Additionally, Sudden Pressure Relaying can quickly detect faults and operate to limit damage to liquid-filled, wire-wound equipment.

What type of devices are classified as fault pressure relay?

There are three main types of fault pressure relays; rapid gas pressure rise, rapid oil pressure rise, and rapid oil flow devices.

Rapid gas pressure devices monitor the pressure in the space above the oil (or other liquid), and initiate tripping action for a rapid rise in gas pressure resulting from the rapid expansion of the liquid caused by a fault. The sensor is located in the gas space.

Rapid oil pressure devices monitor the pressure in the oil (or other liquid), and initiate tripping action for a rapid pressure rise caused by a fault. The sensor is located in the liquid.

Rapid oil flow devices, Buchholz) monitor the liquid flow between a transformer/reactor and its conservator. Normal liquid flow occurs continuously with ambient temperature changes and with internal heating from loading and does not operate the rapid oil flow device. However, when an internal arc occurs, a sudden expansion of liquid can be monitored as rapid liquid flow from the transformer into the conservator resulting in actuation of the rapid oil flow device.

Are sudden pressure relays that only initiate an alarm included in the scope of PRC-005-6?

No--the definition of Sudden Pressure Relaying specifies only those that trip an interrupting device(s) to isolate the equipment it is monitoring.

Are pressure relief devices (PRD) included in the scope of PRC-005-6?

No--PRDs are not included in the Sudden Pressure Relaying definition.

Is Sudden Pressure Relaying installed on distribution transformers included in PRC-005-6?

No--Applicability 4.2.1, 4.2.5, and 4.2.6 explicitly describes what Sudden Pressure Relaying is included within the standard.

Are non-electrical sensing devices (other than fault pressure relays) such as low oil level or high winding temperatures included in PRC-005-6?

No--based on the SPCS technical document, "Sudden Pressure Relays and Other Devices that Respond to Non-Electrical Quantities – December 2013," the only applicable non-electrical sensing devices are Sudden Pressure Relays.

The standard specifically mentions auxiliary and lock-out relays. What is an auxiliary tripping relay?

An auxiliary relay, IEEE Device No. 94, is described in IEEE Standard C37.2-2008 as: "A device that functions to trip a circuit breaker, contactor, or equipment; to permit immediate tripping by other devices; or to prevent immediate reclosing of a circuit interrupter if it should open automatically, even though its closing circuit is maintained closed."

What is a lock-out relay?

A lock-out relay, IEEE Device No. 86, is described in IEEE Standard C37.2 as: "A device that trips and maintains the associated equipment or devices inoperative until it is reset by an operator, either locally or remotely."

3. Protection System and Automatic Reclosing Product Generations

The likelihood of failure and the ability to observe the operational state of a critical Protection System and Automatic Reclosing both depend on the technological generation of the relays, as well as how long they have been in service. Unlike many other transmission asset groups, protection and control systems have seen dramatic technological changes spanning several generations. During the past 20 years, major functional advances are primarily due to the introduction of microprocessor technology for power system devices, such as primary measuring relays, monitoring devices, control systems, and telecommunications equipment.

Modern microprocessor-based relays have six significant traits that impact a maintenance strategy:

- Self-monitoring capability - the processors can check themselves, peripheral circuits, and some connected substation inputs and outputs, such as trip coil continuity. Most relay users are aware that these relays have self-monitoring, but are not focused on exactly what internal functions are actually being monitored. As explained further below, every element critical to the Protection System must be monitored, or else verified periodically.
- Ability to capture Fault records showing how the Protection System responded to a Fault in its zone of protection, or to a nearby Fault for which it is required not to operate.
- Ability to meter currents and voltages, as well as status of connected circuit breakers, continuously during non-Fault times. The relays can compute values, such as MW and Mvar line flows, that are sometimes used for operational purposes, such as SCADA.
- Data communications via ports that provide remote access to all of the results of Protection System monitoring, recording and measurement.
- Ability to trip or close circuit breakers and switches through the Protection System outputs, on command from remote data communications messages, or from relay front panel button requests.
- Construction from electronic components, some of which have shorter technical life or service life than electromechanical components of prior Protection System generations.

There have been significant advances in the technology behind the other components of Protection Systems. Microprocessors are now a part of battery chargers, associated communications equipment, voltage and current-measuring devices, and even the control circuitry (in the form of software-latches replacing lock-out relays, etc.).

Any Protection System component can have self-monitoring and alarming capability, not just relays. Because of this technology, extended time intervals for maintenance and inspection can find their way into all components of the Protection System.

This standard also recognizes the distinct advantage of using advanced technology to justifiably defer or even eliminate traditional maintenance. Just as a hand-held calculator does not require routine testing and calibration, neither does a calculation buried in a microprocessor-based

device that results in a “lock-out.” Thus, the software-latch 86 that replaces an electro-mechanical 86 does not require routine trip testing. Any trip circuitry associated with the “soft 86” would still need applicable verification activities performed, but the actual “86” does not have to be “electrically operated” or even toggled.

4. Definitions

Protection System Maintenance Program (PSMP) — An ongoing program by which Protection System, Automatic Reclosing and Sudden Pressure Relaying Components are kept in working order and proper operation of malfunctioning Components is restored. A maintenance program for a specific Component includes one or more of the following activities:

- Verify — Determine that the Component is functioning correctly.
- Monitor — Observe the routine in-service operation of the Component.
- Test — Apply signals to a Component to observe functional performance or output behavior, or to diagnose problems.
- Inspect — Examine for signs of Component failure, reduced performance and degradation.
- Calibrate — Adjust the operating threshold or measurement accuracy of a measuring element to meet the intended performance requirement.

Automatic Reclosing – Includes the following Components:

- Reclosing relay(s)
- Supervisory relay(s) or function(s) – relay(s) or function(s) that perform voltage and/or sync check functions that enables or disables operation of the reclosing relay
- Voltage sensing devices associated with the supervisory relay(s) or function(s)
- Control circuitry associated with the reclosing relay or supervisory relay(s) or function(s)

Sudden Pressure Relaying – A system that trips an interrupting device(s) to isolate the equipment it is monitoring and includes the following Components:

- Fault pressure relay – a mechanical relay or device that detects rapid changes in gas pressure, oil pressure, or oil flow that are indicative of faults within liquid-filled, wire-wound equipment
- Control circuitry associated with a fault pressure relay

Unresolved Maintenance Issue – A deficiency identified during a maintenance activity that causes the component to not meet the intended performance, cannot be corrected during the maintenance interval, and requires follow-up corrective action.

Segment – Components of a consistent design standard, or a particular model or type from a single manufacturer that typically share other common elements. Consistent performance is expected across the entire population of a Segment. A Segment must contain at least sixty (60) individual Components.

Component Type –

- Any one of the five specific elements of a Protection System.
- Any one of the four specific elements of Automatic Reclosing.
- Any one of the two specific elements of Sudden Pressure Relaying.

Component – Any individual discrete piece of equipment included in a Protection System, Automatic Reclosing, or Sudden Pressure Relaying.

Countable Event – A failure of a Component requiring repair or replacement, any condition discovered during the maintenance activities in Tables 1-1 through 1-5, Table 3, Tables 4-1 through 4-3, and Table 5, which requires corrective action or a Protection System Misoperation attributed to hardware failure or calibration failure. Misoperations due to product design errors, software errors, relay settings different from specified settings, Protection System Component, Automatic Reclosing or Sudden Pressure Relaying configuration or application errors are not included in Countable Events.

4.1 Frequently Asked Questions:

Why does PRC-005-6 not specifically require maintenance and testing procedures, as reflected in the previous standard, PRC-005-1?

PRC-005-1 does not require detailed maintenance and testing procedures, but instead requires summaries of such procedures, and is not clear on what is actually required. PRC-005-6 requires a documented maintenance program, and is focused on establishing requirements rather than prescribing methodology to meet those requirements. Between the activities identified in the Tables 1-1 through 1-5, Table 2, Table 3, and Table 4 (collectively the “Tables”), and the various components of the definition established for a “Protection System Maintenance Program,” PRC-005-6 establishes the activities and time basis for a Protection System Maintenance Program to a level of detail not previously required.

Please clarify what is meant by “restore” in the definition of maintenance.

The description of “restore” in the definition of a Protection System Maintenance Program addresses corrective activities necessary to assure that the component is returned to working order following the discovery of its failure or malfunction. The Maintenance Activities specified in the Tables do not present any requirements related to Restoration; Requirement R5 of the standard does require that the entity “shall demonstrate efforts to correct any identified Unresolved Maintenance Issues.” Some examples of restoration (or correction of Unresolved Maintenance Issues) include, but are not limited to, replacement of capacitors in distance relays to bring them to working order; replacement of relays, or other Protection System components, to bring the Protection System to working order; upgrade of electromechanical or solid-state protective relays to microprocessor-based relays following the discovery of failed components. Restoration, as used in this context, is not to be confused with restoration rules as used in system operations. Maintenance activity necessarily includes both the detection of problems and the repairs needed to eliminate those problems. This standard does not identify all of the Protection System problems that must be detected and eliminated, rather it is the intent of this standard that an entity determines the necessary working order for their various devices, and keeps them in working order. If an equipment item is repaired or replaced, then the entity can restart the maintenance-time-interval-clock, if desired; however, the replacement of equipment does not remove any documentation requirements that would have been required to verify compliance with time-interval requirements. In other words, do not discard maintenance data that goes to verify your work.

The retention of documentation for new and/or replaced equipment provides evidence that the maintenance intervals have been compliant. For example, a long-range plan of upgrades might lead an entity to ignore required maintenance; retaining the evidence of prior maintenance that existed before any retirements and upgrades proves compliance with the standard.

Please clarify what is meant by “...demonstrate efforts to correct an Unresolved Maintenance Issue...;” why not measure the completion of the corrective action?

Management of completion of the identified Unresolved Maintenance Issue is a complex topic that falls outside of the scope of this standard. There can be any number of supply, process and management problems that make setting repair deadlines impossible. The SDT specifically chose the phrase “demonstrate efforts to correct” (with guidance from NERC Staff) because of the concern that many more complex Unresolved Maintenance Issues might require greater than the remaining maintenance interval to resolve (and yet still be a “closed-end process”). For example, a problem might be identified on a VRLA battery during a six-month check. In instances such as one that requiring battery replacement as part of the long-term resolution, it is highly unlikely that the battery could be replaced in time to meet the six-calendar-month requirement for this maintenance activity. The SDT does not believe entities should be found in violation of a maintenance program requirement because of the inability to complete a remediation program within the original maintenance interval. The SDT does believe corrective actions should be timely, but concludes it would be impossible to postulate all possible remediation projects; and, therefore, impossible to specify bounding time frames for resolution of all possible Unresolved Maintenance Issues, or what documentation might be sufficient to provide proof that effective corrective action is being undertaken.

5. Time-Based Maintenance (TBM) Programs

Time-based maintenance is the process in which Protection System, Automatic Reclosing and Sudden Pressure Relaying Components are maintained or verified according to a time schedule. The scheduled program often calls for technicians to travel to the physical site and perform a functional test on Protection System components. However, some components of a TBM program may be conducted from a remote location—for example, tripping a circuit breaker by communicating a trip command to a microprocessor relay to determine if the entire Protection System tripping chain is able to operate the breaker. Similarly, all Protection System, and Sudden Pressure Relaying Components, can have the ability to remotely conduct tests, either on-command or routinely; the running of these tests can extend the time interval between hands-on maintenance activities.

5.1 Maintenance Practices

Maintenance and testing programs often incorporate the following types of maintenance practices:

- TBM – time-based maintenance – externally prescribed maximum maintenance or testing intervals are applied for components or groups of components. The intervals may have been developed from prior experience or manufacturers’ recommendations. The TBM verification interval can be based on a variety of factors, including experience of the particular asset owner, collective experiences of several asset owners who are members of a country or regional council, etc. The maintenance intervals are fixed and may range in number from months to years.

TBM can include review of recent power system events near the particular terminal. Operating records may verify that some portion of the Protection System has operated correctly since the last test occurred. If specific protection scheme components have demonstrated correct performance within specifications, the maintenance test time clock can be reset for those components.

- PBM – Performance-Based Maintenance - intervals are established based on analytical or historical results of TBM failure rates on a statistically significant population of similar components. Some level of TBM is generally followed. Statistical analyses accompanied by adjustments to maintenance intervals are used to justify continued use of PBM-developed extended intervals when test failures or in-service failures occur infrequently.
- CBM – condition-based maintenance – continuously or frequently reported results from non-disruptive self-monitoring of components demonstrate operational status as those components remain in service. Whatever is verified by CBM does not require manual testing, but taking advantage of this requires precise technical focus on exactly what parts are included as part of the self-diagnostics. While the term “Condition-Based-Maintenance” (CBM) is no longer used within the standard itself, it is important to note that the concepts of CBM are a part of the standard (in the form of extended time intervals through status-monitoring). These extended time intervals are only allowed (in the absence of PBM) if the condition of the device is continuously monitored. As a consequence of the “monitored-basis-time-intervals” existing within the standard, the

explanatory discussions within this Supplementary Reference concerned with CBM will remain in this reference and are discussed as CBM.

Microprocessor-based Protection System or Automatic Reclosing Components that perform continuous self-monitoring verify correct operation of most components within the device. Self-monitoring capabilities may include battery continuity, float voltages, unintentional grounds, the ac signal inputs to a relay, analog measuring circuits, processors and memory for measurement, protection, and data communications, trip circuit monitoring, and protection or data communications signals (and many, many more measurements). For those conditions, failure of a self-monitoring routine generates an alarm and may inhibit operation to avoid false trips. When internal components, such as critical output relay contacts, are not equipped with self-monitoring, they can be manually tested. The method of testing may be local or remote, or through inherent performance of the scheme during a system event.

The TBM is the overarching maintenance process of which the other types are subsets. Unlike TBM, PBM intervals are adjusted based on good or bad experiences. The CBM verification intervals can be hours, or even milliseconds between non-disruptive self-monitoring checks within or around components as they remain in service.

TBM, PBM, and CBM can be combined for individual components, or within a complete Protection System. The following diagram illustrates the relationship between various types of maintenance practices described in this section. In the Venn diagram, the overlapping regions show the relationship of TBM with PBM historical information and the inherent continuous monitoring offered through CBM.

This figure shows:

- Region 1: The TBM intervals that are increased based on known reported operational condition of individual components that are monitoring themselves.
- Region 2: The TBM intervals that are adjusted up or down based on results of analysis of maintenance history of statistically significant population of similar products that have been subject to TBM.
- Region 3: Optimal TBM intervals based on regions 1 and 2.

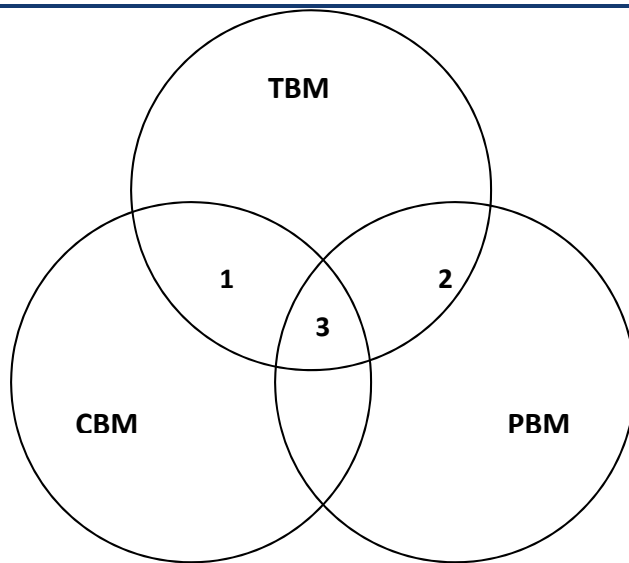

Relationship of time-based maintenance types

5.1.1 Frequently Asked Questions:

The standard seems very complicated, and is difficult to understand. Can it be simplified?

Because the standard is establishing parameters for condition-based Maintenance (Requirement R1) and Performance-Based Maintenance (Requirement R2), in addition to simple time-based Maintenance, it does appear to be complicated. At its simplest, an entity needs to ONLY perform time-based maintenance according to the unmonitored rows of the Tables. If an entity then wishes to take advantage of monitoring on its Protection System components and its available lengthened time intervals, then it may, as long as the component has the listed monitoring attributes. If an entity wishes to use historical performance of its Protection System components to perform Performance-Based Maintenance, then Requirement R2 applies.

Please see the following diagram, which provides a “flow chart” of the standard.

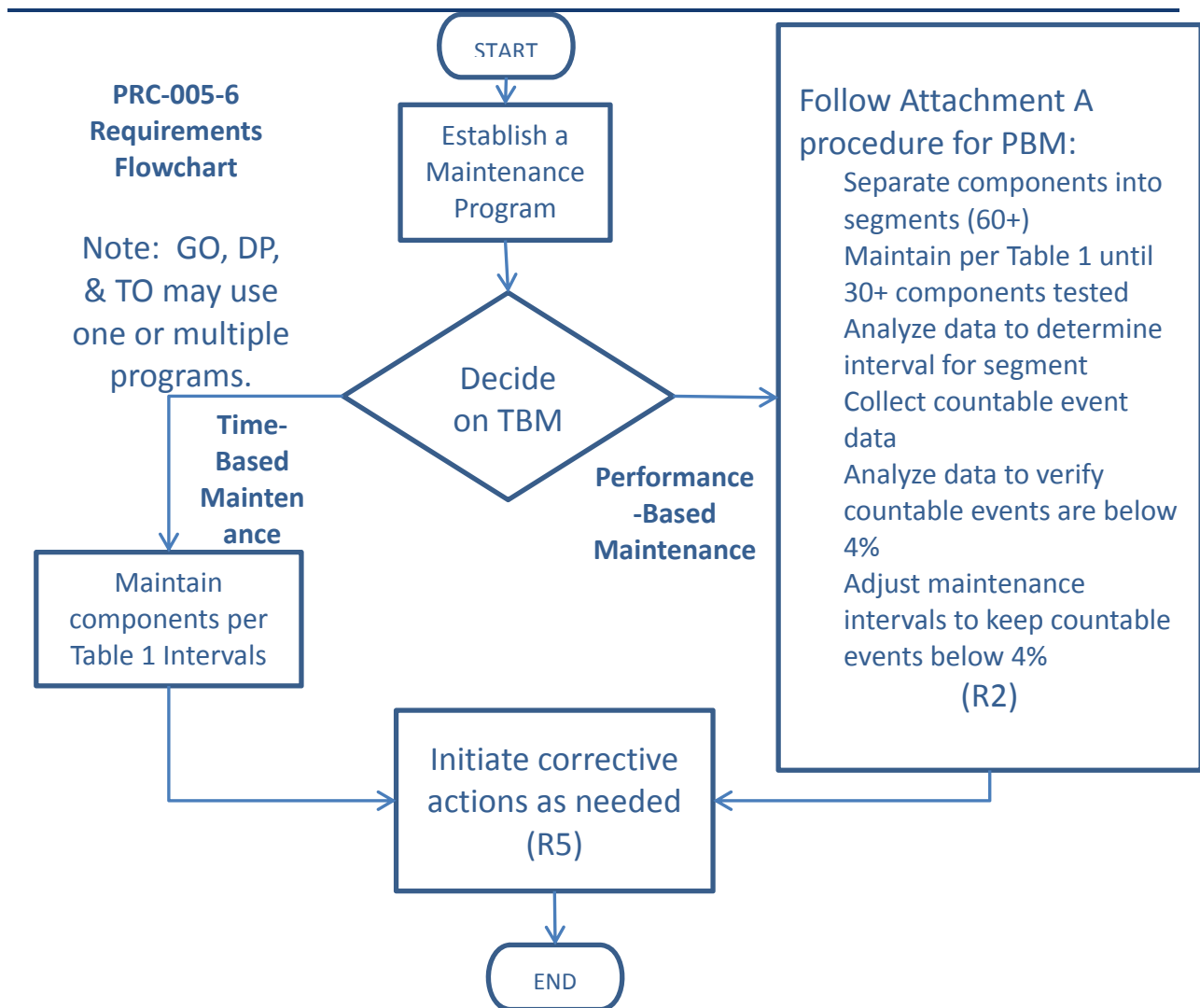

We have an electromechanical (unmonitored) relay that has a trip output to a lockout relay (unmonitored) which trips our transformer off-line by tripping the transformer's high-side and low-side circuit breakers. What testing must be done for this system?

This system is made up of components that are all unmonitored. Assuming a time-based Protection System Maintenance Program schedule (as opposed to a Performance-Based maintenance program), each component must be maintained per the most frequent hands-on activities listed in the Tables.

5.2 Extending Time-Based Maintenance

All maintenance is fundamentally time-based. Default time-based intervals are commonly established to assure proper functioning of each component of the Protection System, when data on the reliability of the components is not available other than observations from time-based maintenance. The following factors may influence the established default intervals:

- If continuous indication of the functional condition of a component is available (from relays or chargers or any self-monitoring device), then the intervals may be extended, or manual testing may be eliminated. This is referred to as condition-based maintenance or CBM. CBM is valid only for precisely the components subject to monitoring. In the case

of microprocessor-based relays, self-monitoring may not include automated diagnostics of every component within a microprocessor.

- Previous maintenance history for a group of components of a common type may indicate that the maintenance intervals can be extended, while still achieving the desired level of performance. This is referred to as Performance-Based Maintenance, or PBM. It is also sometimes referred to as reliability-centered maintenance, or RCM; but PBM is used in this document.
- Observed proper operation of a component may be regarded as a maintenance verification of the respective component or element in a microprocessor-based device. For such an observation, the maintenance interval may be reset only to the degree that can be verified by data available on the operation. For example, the trip of an electromechanical relay for a Fault verifies the trip contact and trip path, but only through the relays in series that actually operated; one operation of this relay cannot verify correct calibration.

Excessive maintenance can actually decrease the reliability of the component or system. It is not unusual to cause failure of a component by removing it from service and restoring it. The improper application of test signals may cause failure of a component. For example, in electromechanical overcurrent relays, test currents have been known to destroy convolution springs.

In addition, maintenance usually takes the component out of service, during which time it is not able to perform its function. Cutout switch failures, or failure to restore switch position, commonly lead to protection failures.

5.2.1 Frequently Asked Questions:

If I show the protective device out of service while it is being repaired, then can I add it back as a new protective device when it returns? If not, my relay testing history would show that I was out of compliance for the last maintenance cycle.

The maintenance and testing requirements (R5) (in essence) state "...shall demonstrate efforts to correct identified Unresolved Maintenance Issues." The type of corrective activity is not stated; however, it could include repairs or replacements.

Your documentation requirements will increase, of course, to demonstrate that your device test failed and had corrective actions initiated. Your regional entity will likely request documentation showing the status of your corrective actions.

6. Condition-Based Maintenance (CBM) Programs

Condition-based maintenance is the process of gathering and monitoring the information available from modern microprocessor-based relays and other intelligent electronic devices (IEDs) that monitor Protection System or Automatic Reclosing elements. These devices generate monitoring information during normal operation, and the information can be assessed at a convenient location remote from the substation. The information from these relays and IEDs is divided into two basic types:

1. Information can come from background self-monitoring processes, programmed by the manufacturer, or by the user in device logic settings. The results are presented by alarm contacts or points, front panel indications, and by data communications messages.
2. Information can come from event logs, captured files, and/or oscillographic records for Faults and Disturbances, metered values, and binary input status reports. Some of these are available on the device front panel display, but may be available via data communications ports. Large files of Fault information can only be retrieved via data communications. These results comprise a mass of data that must be further analyzed for evidence of the operational condition of the Protection System.

Using these two types of information, the user can develop an effective maintenance program carried out mostly from a central location remote from the substation. This approach offers the following advantages:

Non-invasive Maintenance: The system is kept in its normal operating state, without human intervention for checking. This reduces risk of damage, or risk of leaving the system in an inoperable state after a manual test. Experience has shown that keeping human hands away from equipment known to be working correctly enhances reliability.

Virtually Continuous Monitoring: CBM will report many hardware failure problems for repair within seconds or minutes of when they happen. This reduces the percentage of problems that are discovered through incorrect relaying performance. By contrast, a hardware failure discovered by TBM may have been present for much of the time interval between tests, and there is a good chance that some devices will show health problems by incorrect operation before being caught in the next test round. The frequent or continuous nature of CBM makes the effective verification interval far shorter than any required TBM maximum interval. To use the extended time intervals available through Condition Based Maintenance, simply look for the rows in the Tables that refer to monitored items.

6.1 Frequently Asked Questions:

My microprocessor relays and dc circuit alarms are contained on relay panels in a 24-hour attended control room. Does this qualify as an extended time interval condition-based (monitored) system?

Yes, provided the station attendant (plant operator, etc.) monitors the alarms and other indications (comparable to the monitoring attributes) and reports them within the given time limits that are stated in the criteria of the Tables.

When documenting the basis for inclusion of components into the appropriate levels of monitoring, as per Requirement R1 (Part 1.2) of the standard, is it necessary to

provide this documentation about the device by listing of every component and the specific monitoring attributes of each device?

No--While maintaining this documentation on the device level would certainly be permissible, it is not necessary. Global statements can be made to document appropriate levels of monitoring for the entire population of a component type or portion thereof.

For example, it would be permissible to document the conclusion that all BES substation dc supply battery chargers are monitored by stating the following within the program description:

“All substation dc supply battery chargers are considered monitored and subject to the rows for monitored equipment of Table 1-4 requirements, as all substation dc supply battery chargers are equipped with dc voltage alarms and ground detection alarms that are sent to the manned control center.”

Similarly, it would be acceptable to use a combination of a global statement and a device-level list of exclusions. Example:

“Except as noted below, all substation dc supply battery chargers are considered monitored and subject to the rows for monitored equipment of Table 1-4 requirements, as all substation dc supply battery chargers are equipped with dc voltage alarms and ground detection alarms that are sent to the manned control center. The dc supply battery chargers of Substation X, Substation Y, and Substation Z are considered unmonitored and subject to the rows for unmonitored equipment in Table 1-4 requirements, as they are not equipped with ground detection capability.”

Regardless whether this documentation is provided by device listing of monitoring attributes, by global statements of the monitoring attributes of an entire population of component types, or by some combination of these methods, it should be noted that auditors may request supporting drawings or other documentation necessary to validate the inclusion of the device(s) within the appropriate level of monitoring. This supporting background information need not be maintained within the program document structure, but should be retrievable if requested by an auditor.

7. Time-Based Versus Condition-Based Maintenance

Time-based and condition-based (or monitored) maintenance programs are both acceptable, if implemented according to technically sound requirements. Practical programs can employ a combination of time-based and condition-based maintenance. The standard requirements introduce the concept of optionally using condition monitoring as a documented element of a maintenance program.

The Federal Energy Regulatory Commission (FERC), in its Order Number 693 Final Rule, dated March 16, 2007 (18 CFR Part 40, Docket No. RM06-16-000) on Mandatory Reliability Standards for the Bulk-Power System, directed NERC to submit a modification to PRC-005-1b that includes a requirement that maintenance and testing of a Protection System must be carried out within a maximum allowable interval that is appropriate to the type of the Protection System and its impact on the reliability of the Bulk Power System. Accordingly, this Supplementary Reference Paper refers to the specific maximum allowable intervals in PRC-005-6. The defined time limits allow for longer time intervals if the maintained component is monitored.

A key feature of condition-based monitoring is that it effectively reduces the time delay between the moment of a protection failure and time the Protection System or Automatic Reclosing owner knows about it, for the monitored segments of the Protection System. In some cases, the verification is practically continuous--the time interval between verifications is minutes or seconds. Thus, technically sound, condition-based verification, meets the verification requirements of the FERC order even more effectively than the strictly time-based tests of the same system components.

The result is that:

This NERC standard permits applicable entities to use a technically sound approach and to take advantage of remote monitoring, data analysis, and control capabilities of modern Protection System and Automatic Reclosing Components to reduce the need for periodic site visits and invasive testing of components by on-site technicians. This periodic testing must be conducted within the maximum time intervals specified in the Tables of PRC-005-6.

7.1 Frequently Asked Questions:

What is a Calendar Year?

Calendar Year - January 1 through December 31 of any year. As an example, if an event occurred on June 17, 2009 and is on a "One Calendar Year Interval," the next event would have to occur on or before December 31, 2010.

Please provide an example of "4 Calendar Months".

If a maintenance activity is described as being needed every four Calendar Months then it is performed in a (given) month and due again four months later. For example a battery bank is inspected in month number 1 then it is due again before the end of the month number 5. And specifically consider that you perform your battery inspection on January 3 then it must be inspected again before the end of May. Another example could be that a four-month inspection was performed in January is due in May, but if performed in March (instead of May) would still

be due four months later therefore the activity is due again July. Basically every “four Calendar Months” means to add four months from the last time the activity was performed and perform the activity by the end of the fourth month.

Please provide an example of the unmonitored versus other levels of monitoring available?

An unmonitored Protection System has no monitoring and alarm circuits on the Protection System components. A Protection System component that has monitoring attributes but no alarm output connected is considered to be unmonitored.

A monitored Protection System or an individual monitored component of a Protection System has monitoring and alarm circuits on the Protection System components. The alarm circuits must alert, within 24 hours, a location wherein corrective action can be initiated. This location might be, but is not limited to, an Operations Center, Dispatch Office, Maintenance Center or even a portable SCADA system.

There can be a combination of monitored and unmonitored Protection Systems within any given scheme, substation or plant; there can also be a combination of monitored and unmonitored components within any given Protection System.

Example #1: A combination of monitored and unmonitored components within a given Protection System might be:

- A microprocessor relay with an internal alarm connected to SCADA to alert 24-hr staffed operations center; it has internal self-diagnosis and alarming. (monitored)
- Instrumentation transformers, with no monitoring, connected as inputs to that relay. (unmonitored)
- A vented Lead-Acid battery with a low voltage alarm for the station dc supply voltage and an unintentional grounds detection alarm connected to SCADA. (monitoring varies)
- A circuit breaker with a trip coil, and the trip circuit is not monitored. (unmonitored)

Given the particular components and conditions, and using Table 1 and Table 2, the particular components have maximum activity intervals of:

Every four calendar months, inspect:

- Electrolyte level (station dc supply voltage and unintentional ground detection is being maintained more frequently by the monitoring system).

Every 18 calendar months, verify/inspect the following:

- Battery bank ohmic values to station battery baseline (if performance tests are not opted)
- Battery charger float voltage
- Battery rack integrity
- Cell condition of all individual battery cells (where visible)
- Battery continuity

-
- Battery terminal connection resistance
 - Battery cell-to-cell resistance (where available to measure)

Every six calendar years, perform/verify the following:

- Battery performance test (if internal ohmic tests or other measurements indicative of battery performance are not opted)
- Verify that each trip coil is able to operate the circuit breaker, interrupting device, or mitigating device
- For electromechanical lock-out relays, electrical operation of electromechanical trip

Every 12 calendar years, verify the following:

- Microprocessor relay settings are as specified
- Operation of the microprocessor's relay inputs and outputs that are essential to proper functioning of the Protection System
- Acceptable measurement of power System input values seen by the microprocessor protective relay
- Verify that current and voltage signal values are provided to the protective relays
- Protection System component monitoring for the battery system signals are conveyed to a location where corrective action can be initiated
- The microprocessor relay alarm signals are conveyed to a location where corrective action can be initiated
- Verify all trip paths in the control circuitry associated with protective functions through the trip coil(s) of the circuit breakers or other interrupting devices
- Auxiliary outputs that are in the trip path shall be maintained as detailed in Table 1-5 of the standard under the 'Unmonitored Control Circuitry Associated with Protective Functions' section'
- Auxiliary outputs not in a trip path (i.e., annunciation or DME input) are not required, by this standard, to be checked

Example #2: A combination of monitored and unmonitored components within a given Protection System might be:

- A microprocessor relay with integral alarm that is not connected to SCADA. (unmonitored)
- Current and voltage signal values, with no monitoring, connected as inputs to that relay. (unmonitored)
- A vented lead-acid battery with a low voltage alarm for the station dc supply voltage and an unintentional grounds detection alarm connected to SCADA. (monitoring varies)
- A circuit breaker with a trip coil, with no circuits monitored. (unmonitored)

Given the particular components and conditions, and using the Table 1 (Maximum Allowable Testing Intervals and Maintenance Activities) and Table 2 (Alarming Paths and Monitoring), the particular components have maximum activity intervals of:

Every four calendar months, inspect:

- Electrolyte level (station dc supply voltage and unintentional ground detection is being maintained more frequently by the monitoring system)

Every 18 calendar months, verify/inspect the following:

- Battery bank trending of ohmic values or other measurements indicative of battery performance to station battery baseline (if performance tests are not opted)
- Battery charger float voltage
- Battery rack integrity
- Cell condition of all individual battery cells (where visible)
- Battery continuity
- Battery terminal connection resistance
- Battery cell-to-cell resistance (where available to measure)

Every six calendar years, verify/perform the following:

- Verify operation of the relay inputs and outputs that are essential to proper functioning of the Protection System
- Verify acceptable measurement of power system input values as seen by the relays
- Verify that each trip coil is able to operate the circuit breaker, interrupting device, or mitigating device
- For electromechanical lock-out relays, electrical operation of electromechanical trip
- Battery performance test (if internal ohmic tests are not opted)

Every 12 calendar years, verify the following:

- Current and voltage signal values are provided to the protective relays
- Protection System component monitoring for the battery system signals are conveyed to a location where corrective action can be initiated
- All trip paths in the control circuitry associated with protective functions through the trip coil(s) of the circuit breakers or other interrupting devices
- Auxiliary outputs that are in the trip path shall be maintained, as detailed in Table 1-5 of the standard under the Unmonitored Control Circuitry Associated with Protective Functions" section
- Auxiliary outputs not in a trip path (i.e., annunciation or DME input) are not required, by this standard, to be checked

Example #3: A combination of monitored and unmonitored components within a given Protection System might be:

- A microprocessor relay with alarm connected to SCADA to alert 24-hr staffed operations center; it has internal self-diagnosis and alarms. (monitored)
- Current and voltage signal values, with monitoring, connected as inputs to that relay (monitored)
- Vented Lead-Acid battery without any alarms connected to SCADA (unmonitored)
- Circuit breaker with a trip coil, with no circuits monitored (unmonitored)

Given the particular components, conditions, and using the Table 1 (Maximum Allowable Testing Intervals and Maintenance Activities) and Table 2 (Alarming Paths and Monitoring), the particular components shall have maximum activity intervals of:

Every four calendar months, verify/inspect the following:

- Station dc supply voltage
- For unintentional grounds
- Electrolyte level

Every 18 calendar months, verify/inspect the following:

- Battery bank trending of ohmic values or other measurements indicative of battery performance to station battery baseline (if performance tests are not opted)
- Battery charger float voltage
- Battery rack integrity
- Battery continuity
- Battery terminal connection resistance
- Battery cell-to-cell resistance (where available to measure)
- Condition of all individual battery cells (where visible)

Every six calendar years, perform/verify the following:

- Battery performance test (if internal ohmic tests or other measurements indicative of battery performance are not opted)
- Verify that each trip coil is able to operate the circuit breaker, interrupting device, or mitigating device
- For electromechanical lock-out relays, electrical operation of electromechanical trip

Every 12 calendar years, verify the following:

- The microprocessor relay alarm signals are conveyed to a location where corrective action can be taken
- Microprocessor relay settings are as specified
- Operation of the microprocessor's relay inputs and outputs that are essential to proper functioning of the Protection System

-
- Acceptable measurement of power system input values seen by the microprocessor protective relay
 - Verify all trip paths in the control circuitry associated with protective functions through the trip coil(s) of the circuit breakers or other interrupting devices
 - Auxiliary outputs that are in the trip path shall be maintained, as detailed in Table 1-5 of the standard under the Unmonitored Control Circuitry Associated with Protective Functions section
 - Auxiliary outputs not in a trip path (i.e. annunciation or DME input) are not required, by this standard, to be checked

Why do components have different maintenance activities and intervals if they are monitored?

The rationale supporting different activities and intervals for monitored equipment is to allow less frequent manual intervention when more information is known about the condition of Protection System components. Condition-Based Maintenance is a valuable asset to improve reliability.

Can all components in a Protection System be monitored?

No--For some components in a Protection System, monitoring will not be relevant. For example, a battery will always need some kind of inspection.

We have a 30-year-old oil circuit breaker with a red indicating lamp on the substation relay panel that is illuminated only if there is continuity through the breaker trip coil. There is no SCADA monitor or relay monitor of this trip coil. The line protection relay package that trips this circuit breaker is a microprocessor relay that has an integral alarm relay that will assert on a number of conditions that includes a loss of power to the relay. This alarm contact connects to our SCADA system and alerts our 24-hour operations center of relay trouble when the alarm contact closes. This microprocessor relay trips the circuit breaker only and does not monitor trip coil continuity or other things such as trip current. Are the components monitored or not? How often must I perform maintenance?

The protective relay is monitored and can be maintained every 12 years, or when an Unresolved Maintenance Issue arises. The control circuitry can be maintained every 12 years. The circuit breaker trip coil(s) has to be electrically operated at least once every six years.

What is a mitigating device?

A mitigating device is the device that acts to respond as directed by a Remedial Action Schemes. It may be a breaker, valve, distributed control system, or any variety of other devices. This response may include tripping, closing, or other control actions.

8. Maximum Allowable Verification Intervals

The maximum allowable testing intervals and maintenance activities show how CBM with newer device types can reduce the need for many of the tests and site visits that older Protection System components require. As explained below, there are some sections of the Protection System that monitoring or data analysis may not verify. Verifying these sections of the Protection System or Automatic Reclosing requires some persistent TBM activity in the maintenance program. However, some of this TBM can be carried out remotely—for example, exercising a circuit breaker through the relay tripping circuits using the relay remote control capabilities can be used to verify function of one tripping path and proper trip coil operation, if there has been no Fault or routine operation to demonstrate performance of relay tripping circuits.

8.1 Maintenance Tests

Periodic maintenance testing is performed to ensure that the protection and control system is operating correctly after a time period of field installation. These tests may be used to ensure that individual components are still operating within acceptable performance parameters - this type of test is needed for components susceptible to degraded or changing characteristics due to aging and wear. Full system performance tests may be used to confirm that the total Protection System functions from measurement of power system values, to properly identifying Fault characteristics, to the operation of the interrupting devices.

8.1.1 Table of Maximum Allowable Verification Intervals

Table 1 (collectively known as Table 1, individually called out as Tables 1-1 through 1-5), Table 2, Table 3, Table 4-1 through Table 4-3, and Table 5 in the standard specify maximum allowable verification intervals for various generations of Protection Systems, Automatic Reclosing and Sudden Pressure Relaying and categories of equipment that comprise these systems. The right column indicates maintenance activities required for each category.

The types of components are illustrated in [Figures 1](#) and [2](#) at the end of this paper. Figure 1 shows an example of telecommunications-assisted transmission Protection System comprising substation equipment at each terminal and a telecommunications channel for relaying between the two substations. [Figure 2](#) shows an example of a generation Protection System. The various sub-systems of a Protection System that need to be verified are shown.

Non-distributed UFLS, UVLS, and RAS are additional categories of Table 1 that are not illustrated in these figures. Non-distributed UFLS, UVLS and RAS all use identical equipment as Protection Systems in the performance of their functions; and, therefore, have the same maintenance needs.

Distributed UFLS and UVLS Systems, which use local sensing on the distribution System and trip co-located non-BES interrupting devices, are addressed in Table 3 with reduced maintenance activities.

While it is easy to associate protective relays to multiple levels of monitoring, it is also true that most of the components that can make up a Protection System can also have technological advancements that place them into higher levels of monitoring.

To use the Maintenance Activities and Intervals Tables from PRC-005-6:

-
- First find the Table associated with your component. The tables are arranged in the order of mention in the definition of Protection System;
 - Table 1-1 is for protective relays.
 - Table 1-2 is for the associated communications systems.
 - Table 1-3 is for current and voltage sensing devices.
 - Table 1-4 is for station dc supply.
 - Table 1-5 is for control circuits.
 - Table 2, is for alarms; this was broken out to simplify the other tables.
 - Table 3 is for components which make-up distributed UFLS and UVLS Systems.
 - Table 4 is for Automatic Reclosing.
 - Table 5 is for Sudden Pressure Relaying.
 - Next, look within that table for your device and its degree of monitoring. The Tables have different hands-on maintenance activities prescribed depending upon the degree to which you monitor your equipment. Find the maintenance activity that applies to the monitoring level that you have on your piece of equipment.
 - This Maintenance activity is the minimum maintenance activity that must be documented.
 - If your Performance-Based Maintenance (PBM) plan requires more activities, then you must perform and document to this higher standard. (Note that this does not apply unless you utilize PBM.)
 - After the maintenance activity is known, check the maximum maintenance interval; this time is the maximum time allowed between hands-on maintenance activity cycles of this component.
 - If your Performance-Based Maintenance plan requires activities more often than the Tables maximum, then you must perform and document those activities to your more stringent standard. (Note that this does not apply unless you utilize PBM.)
 - Any given component of a Protection System can be determined to have a degree of monitoring that may be different from another component within that same Protection System. For example, in a given Protection System it is possible for an entity to have a monitored protective relay and an unmonitored associated communications system; this combination would require hands-on maintenance activity on the relay at least once every 12 years and attention paid to the communications system as often as every four months.
 - An entity does not have to utilize the extended time intervals made available by this use of condition-based monitoring. An easy choice to make is to simply utilize the unmonitored level of maintenance made available in each of the Tables. While the maintenance activities resulting from this choice would require more maintenance man-

hours, the maintenance requirements may be simpler to document and the resulting maintenance plans may be easier to create.

For each Protection System Component, Table 1 shows maximum allowable testing intervals for the various degrees of monitoring. For each Automatic Reclosing Component, Table 4 shows maximum allowable testing intervals for the various degrees of monitoring. These degrees of monitoring, or levels, range from the legacy unmonitored through a system that is more comprehensively monitored.

It has been noted here that an entity may have a PSMP that is more stringent than PRC-005-6. There may be any number of reasons that an entity chooses a more stringent plan than the minimums prescribed within PRC-005-6, most notable of which is an entity using performance based maintenance methodology.

If an entity has a Performance-Based Maintenance program, then that plan must be followed, even if the plan proves to be more stringent than the minimums laid out in the Tables.

If an entity has a Time-Based Maintenance program and the PSMP is more stringent than PRC-005-6, they will only be audited in accordance with the standard (minimum maintenance activities and maximum maintenance intervals prescribed within Tables 1-1 through 1-5, Table 2, Table 3, Table 4-1 through 4-3, and Table 5).

8.1.2 Additional Notes for Tables 1-1 through 1-5, Table 3, and Table 4

1. For electromechanical relays, adjustment is required to bring measurement accuracy within the tolerance needed by the asset owner. Microprocessor relays with no remote monitoring of alarm contacts, etc., are unmonitored relays and need to be verified within the Table interval as other unmonitored relays but may be verified as functional by means other than testing by simulated inputs.
2. Microprocessor relays typically are specified by manufacturers as not requiring calibration, but acceptable measurement of power system input values must be verified (verification of the Analog to Digital [A/D] converters) within the Table intervals. The integrity of the digital inputs and outputs that are used as protective functions must be verified within the Table intervals.
3. Any Phasor Measurement Unit (PMU) function whose output is used in a Protection System or RAS (as opposed to a monitoring task) must be verified as a component in a Protection System.
4. In addition to verifying the circuitry that supplies dc to the Protection System, the owner must maintain the station dc supply. The most widespread station dc supply is the station battery and charger. Unlike most Protection System components, physical inspection of station batteries for signs of component failure, reduced performance, and degradation are required to ensure that the station battery is reliable enough to deliver dc power when required. IEEE Standards 450, 1188, and 1106 for vented lead-acid, valve-regulated lead-acid, and nickel-cadmium batteries, respectively (which are the most commonly used substation batteries on the NERC BES) have been developed as an important reference source of maintenance recommendations. The Protection System owner might want to follow the guidelines in the applicable IEEE recommended practices for battery maintenance and testing, especially if the battery in question is used for application requirements in addition to the protection and control demands covered under this

standard. However, the Standard Drafting Team has tailored the battery maintenance and testing guidelines in PRC-005-6 for the Protection System owner which are application specific for the BES Facilities. While the IEEE recommendations are all encompassing, PRC-005-6 is a more economical approach while addressing the reliability requirements of the BES.

5. Aggregated small entities might distribute the testing of the population of UFLS/UVLS systems, and large entities will usually maintain a portion of these systems in any given year. Additionally, if relatively small quantities of such systems do not perform properly, it will not affect the integrity of the overall program. Thus, these distributed systems have decreased requirements as compared to other Protection Systems.
6. Voltage and current sensing device circuit input connections to the Protection System relays can be verified by (but not limited to) comparison of measured values on live circuits or by using test currents and voltages on equipment out of service for maintenance. The verification process can be automated or manual. The values should be verified to be as expected (phase value and phase relationships are both equally important to verify).
7. “End-to-end test,” as used in this Supplementary Reference, is any testing procedure that creates a remote input to the local communications-assisted trip scheme. While this can be interpreted as a GPS-type functional test, it is not limited to testing via GPS. Any remote scheme manipulation that can cause action at the local trip path can be used to functionally-test the dc control circuitry. A documented Real-time trip of any given trip path is acceptable in lieu of a functional trip test. It is possible, with sufficient monitoring, to be able to verify each and every parallel trip path that participated in any given dc control circuit trip. Or another possible solution is that a single trip path from a single monitored relay can be verified to be the trip path that successfully tripped during a Real-time operation. The variations are only limited by the degree of engineering and monitoring that an entity desires to pursue.
8. A/D verification may use relay front panel value displays, or values gathered via data communications. Groupings of other measurements (such as vector summation of bus feeder currents) can be used for comparison if calibration requirements assure acceptable measurement of power system input values.
9. Notes 1-8 attempt to describe some testing activities; they do not represent the only methods to achieve these activities, but rather some possible methods. Technological advances, ingenuity and/or industry accepted techniques can all be used to satisfy maintenance activity requirements; the standard is technology- and method-neutral in most cases.

8.1.3 Frequently Asked Questions:

What is meant by “Verify that settings are as specified” maintenance activity in Table 1-1?

Verification of settings is an activity directed mostly towards microprocessor- based relays. For relay maintenance departments that choose to test microprocessor-based relays in the same manner as electromechanical relays are tested, the testing process sometimes requires

that some specific functions be disabled. Later tests might enable the functions previously disabled, but perhaps still other functions or logic statements were then masked out. It is imperative that, when the relay is placed into service, the settings in the relay be the settings that were intended to be in that relay or as the standard states "...settings are as specified."

Many of the microprocessor-based relays available today have software tools which provide this functionality and generate reports for this purpose.

For evidence or documentation of this requirement, a simple recorded acknowledgement that the settings were checked to be as specified is sufficient.

The drafting team was careful not to require "...that the relay settings be correct..." because it was believed that this might then place a burden of proof that the specified settings would result in the correct intended operation of the interrupting device. While that is a noble intention, the measurable proof of such a requirement is immense. The intent is that settings of the component be as specified at the conclusion of maintenance activities, whether those settings may have "drifted" since the prior maintenance or whether changes were made as part of the testing process.

Are electromechanical relays included in the "Verify that settings are as specified" maintenance activity in Table 1-1?

Verification of settings is an activity directed towards the application of protection related functions of microprocessor based relays. Electromechanical relays require calibration verification by voltage and/or current injection; and, thus, the settings are verified during calibration activity. In the example of a time-overcurrent relay, a minor deviation in time dial, versus the settings, may be acceptable, as long as the relay calibration is within accepted tolerances at the injected current amplitudes. A major deviation may require further investigation, as it could indicate a problem with the relay or an incorrect relay style for the application.

The verification of phase current and voltage measurements by comparison to other quantities seems reasonable. How, though, can I verify residual or neutral currents, or 3V0 voltages, by comparison, when my system is closely balanced?

Since these inputs are verified at commissioning, maintenance verification requires ensuring that phase quantities are as expected and that 3IO and 3VO quantities appear equal to or close to 0.

These quantities also may be verified by use of oscillographic records for connected microprocessor relays as recorded during system Disturbances. Such records may compare to similar values recorded at other locations by other microprocessor relays for the same event, or compared to expected values (from short circuit studies) for known Fault locations.

What does this Standard require for testing an auxiliary tripping relay?

Table 1 and Table 3 requires that a trip test must verify that the auxiliary tripping relay(s) and/or lockout relay(s) which are directly in a trip path from the protective relay to the interrupting device trip coil operate(s) electrically. Auxiliary outputs not in a trip path (i.e. annunciation or DME input) are not required, by this standard, to be checked.

Do I have to perform a full end-to-end test of a Remedial Action Schemes?

No--all portions of the RAS need to be maintained, and the portions must overlap, but the overall RAS does not need to have a single end-to-end test. In other words it may be tested in piecemeal fashion provided all of the pieces are verified.

What about RAS interfaces between different entities or owners?

As in all of the Protection System requirements, RAS segments can be tested individually, thus minimizing the need to accommodate complex maintenance schedules.

What do I have to do if I am using a phasor measurement unit (PMU) as part of a Protection System or Remedial Action Schemes?

Any Phasor Measurement Unit (PMU) function whose output is used in a Protection System or Remedial Action Schemes (as opposed to a monitoring task) must be verified as a component in a Protection System.

How do I maintain a Remedial Action Schemes or relay sensing for non-distributed UFLS or UVLS Systems?

Since components of the RAS, UFLS and UVLS are the same types of components as those in Protection Systems, then these components should be maintained like similar components used for other Protection System functions. In many cases the devices for RAS, UFLS and UVLS are also used for other protective functions. The same maintenance activities apply with the exception that distributed systems (UFLS and UVLS) have fewer dc supply and control circuitry maintenance activity requirements.

For the testing of the output action, verification may be by breaker tripping, but may be verified in overlapping segments. For example, an RAS that trips a remote circuit breaker might be tested by testing the various parts of the scheme in overlapping segments. Another method is to document the Real-time tripping of an RAS scheme should that occur. Forced trip tests of circuit breakers (etc.) that are a part of distributed UFLS or UVLS schemes are not required.

The established maximum allowable intervals do not align well with the scheduled outages for my power plant. Can I extend the maintenance to the next scheduled outage following the established maximum interval?

No--you must complete your maintenance within the established maximum allowable intervals in order to be compliant. You will need to schedule your maintenance during available outages to complete your maintenance as required, even if it means that you may do protective relay maintenance more frequently than the maximum allowable intervals. The maintenance intervals were selected with typical plant outages, among other things, in mind.

If I am unable to complete the maintenance, as required, due to a major natural disaster (hurricane, earthquake, etc.), how will this affect my compliance with this standard?

The Sanction Guidelines of the North American Electric Reliability Corporation, effective January 15, 2008, provides that the Compliance Monitor will consider extenuating circumstances when considering any sanctions.

What if my observed testing results show a high incidence of out-of-tolerance relays; or, even worse, I am experiencing numerous relay Misoperations due to the relays being out-of-tolerance?

The established maximum time intervals are mandatory only as a not-to-exceed limitation. The establishment of a maximum is measurable. But any entity can choose to test some or all of their Protection System components more frequently (or to express it differently, exceed the minimum requirements of the standard). Particularly if you find that the maximum intervals in the standard do not achieve your expected level of performance, it is understandable that you would maintain the related equipment more frequently. A high incidence of relay Misoperations is in no one's best interest.

We believe that the four-month interval between inspections is unnecessary. Why can we not perform these inspections twice per year?

The Standard Drafting Team, through the comment process, has discovered that routine monthly inspections are not the norm. To align routine station inspections with other important inspections, the four-month interval was chosen. In lieu of station visits, many activities can be accomplished with automated monitoring and alarming.

Our maintenance plan calls for us to perform routine protective relay tests every 3 years. If we are unable to achieve this schedule, but we are able to complete the procedures in less than the maximum time interval, then are we in or out of compliance?

According to Requirement R3, if you have a time-based maintenance program, then you will be in violation of the standard only if you exceed the maximum maintenance intervals prescribed in the Tables. According to Requirement R4, if your device in question is part of a Performance-Based Maintenance program, then you will be in violation of the standard if you fail to meet your PSMP, even if you do not exceed the maximum maintenance intervals prescribed in the Tables. The intervals in the Tables are associated with TBM and CBM; Attachment A is associated with PBM.

Please provide a sample list of devices or systems that must be verified in a generator, generator step-up transformer, generator connected station service or generator connected excitation transformer to meet the requirements of this maintenance standard.

Examples of typical devices and systems that may directly trip the generator, or trip through a lockout relay, may include, but are not necessarily limited to:

- Fault protective functions, including distance functions, voltage-restrained overcurrent functions, or voltage-controlled overcurrent functions
- Loss-of-field relays
- Volts-per-hertz relays
- Negative sequence overcurrent relays
- Over voltage and under voltage protection relays
- Stator-ground relays
- Communications-based Protection Systems such as transfer-trip systems

-
- Generator differential relays
 - Reverse power relays
 - Frequency relays
 - Out-of-step relays
 - Inadvertent energization protection
 - Breaker failure protection

For generator step-up, generator-connected station service transformers, or generator connected excitation transformers, operation of any of the following associated protective relays frequently would result in a trip of the generating unit; and, as such, would be included in the program:

- Transformer differential relays
- Neutral overcurrent relay
- Phase overcurrent relays
- Sudden Pressure Relaying

Relays which trip breakers serving station auxiliary Loads such as pumps, fans, or fuel handling equipment, etc., need not be included in the program, even if the loss of the those Loads could result in a trip of the generating unit. Furthermore, relays which provide protection to secondary unit substation (SUS) or low switchgear transformers and relays protecting other downstream plant electrical distribution system components are not included in the scope of this program, even if a trip of these devices might eventually result in a trip of the generating unit. For example, a thermal overcurrent trip on the motor of a coal-conveyor belt could eventually lead to the tripping of the generator, but it does not cause the trip.

In the case where a plant does not have a generator connected station service transformer such that it is normally fed from a system connected station service transformer, is it still the drafting team's intent to exclude the Protection Systems for these system connected auxiliary transformers from scope even when the loss of the normal (system connected) station service transformer will result in a trip of a BES generating Facility?

The SDT does not intend that the system-connected station service transformers be included in the Applicability. The generator-connected station service transformers and generator connected excitation transformers are often connected to the generator bus directly without an interposing breaker; thus, the Protection Systems on these transformers will trip the generator as discussed in 4.2.5.1.

What is meant by "verify operation of the relay inputs and outputs that are essential to proper functioning of the Protection System?"

Any input or output (of the relay) that "affects the tripping" of the breaker is included in the scope of I/O of the relay to be verified. By "affects the tripping," one needs to realize that sometimes there are more inputs and outputs than simply the output to the trip coil. Many

important protective functions include things like breaker fail initiation, zone timer initiation and sometimes even 52a/b contact inputs are needed for a protective relay to correctly operate.

Each input should be “picked up” or “turned on and off” and verified as changing state by the microprocessor of the relay. Each output should be “operated” or “closed and opened” from the microprocessor of the relay and the output should be verified to change state on the output terminals of the relay. One possible method of testing inputs of these relays is to “jumper” the needed dc voltage to the input and verify that the relay registered the change of state.

Electromechanical lock-out relays (86) (used to convey the tripping current to the trip coils) need to be electrically operated to prove the capability of the device to change state. These tests need to be accomplished at least every six years, unless PBM methodology is applied.

The contacts on the 86 or auxiliary tripping relays (94) that change state to pass on the trip current to a breaker trip coil need only be checked every 12 years with the control circuitry.

What is the difference between a distributed UFLS/UVLS and a non-distributed UFLS/UVLS scheme?

A distributed UFLS or UVLS scheme contains individual relays which make independent Load shed decisions based on applied settings and localized voltage and/or current inputs. A distributed scheme may involve an enable/disable contact in the scheme and still be considered a distributed scheme. A non-distributed UFLS or UVLS scheme involves a system where there is some type of centralized measurement and Load shed decision being made. A non-distributed UFLS/UVLS scheme is considered similar to an RAS scheme and falls under Table 1 for maintenance activities and intervals.

8.2 Retention of Records

PRC-005-1 describes a reporting or auditing cycle of one year and retention of records for three years. However, with a three-year retention cycle, the records of verification for a Protection System might be discarded before the next verification, leaving no record of what was done if a Misoperation or failure is to be analyzed.

PRC-005-6 corrects this by requiring:

The Transmission Owner, Generator Owner, and Distribution Provider shall each keep data or evidence to show compliance as identified below unless directed by its Compliance Enforcement Authority to retain specific evidence for a longer period of time as part of an investigation.

For Requirement R1, the Transmission Owner, Generator Owner, and Distribution Provider shall each keep its current dated Protection System Maintenance Program, as well as any superseded versions since the preceding compliance audit, including the documentation that specifies the type of maintenance program applied for each Protection System, Automatic Reclosing, or Sudden Pressure Relaying Component Type.

For Requirement R2, Requirement R3, and Requirement R4, in cases where the interval of the maintenance activity is longer than the audit cycle, the Transmission Owner, Generator Owner, and Distribution Provider shall each keep documentation of the most recent performance of that maintenance activity for the Protection System, Automatic Reclosing, or Sudden Pressure Relaying Component. In cases where the interval of the maintenance activity is shorter than the audit cycle, documentation of all performances

(in accordance with the tables) of that maintenance activity for the Protection System, Automatic Reclosing, or Sudden Pressure Relaying Component since the previous scheduled audit date shall be retained.

For Requirement R5 the Transmission Owner, Generator Owner, and Distribution Provider shall each keep documentation of Unresolved Maintenance Issues identified by the entity since the last audit, including all that were resolved since the last audit.

This requirement assures that the documentation shows that the interval between maintenance cycles correctly meets the maintenance interval limits. The requirement is actually alerting the industry to documentation requirements already implemented by audit teams. Evidence of compliance bookending the interval shows interval accomplished instead of proving only your planned interval.

The SDT is aware that, in some cases, the retention period could be relatively long. But, the retention of documents simply helps to demonstrate compliance.

8.2.1 Frequently Asked Questions:

Please clarify the data retention requirements.

The data retention requirements are intended to allow the availability of maintenance records to demonstrate that the time intervals in your maintenance plan were upheld.

<u>Maximum Maintenance Interval</u>	<u>Data Retention Period</u>
4 Months, 6 Months, 18 Months, or 3 Years	All activities since previous audit
6 Years	All activities since previous audit (assuming a 6 year audit cycle) or most recent performance (assuming 3 year audit cycle), whichever is longer
12 Year	All activities from the most recent performance

If an entity prefers to utilize Performance-Based Maintenance, then statistical data may be retained for extended periods to assist with future adjustments in time intervals.

If an equipment item is replaced, then the entity can restart the maintenance-time-interval-clock if desired; however, the replacement of equipment does not remove any documentation requirements that would have been required to verify compliance with time-interval requirements. In other words, do not discard maintenance data that goes to verify your work.

The retention of documentation for new and/or replaced equipment is all about proving that the maintenance intervals had been in compliance. For example, a long-range plan of upgrades might lead an entity to ignore required maintenance; retaining the evidence of prior maintenance that existed before any retirements and upgrades proves compliance with the standard.

What does this Maintenance Standard say about commissioning? Is it necessary to have documentation in your maintenance history of the completion of commission testing?

This standard does not establish requirements for commission testing. Commission testing includes all testing activities necessary to conclude that a Facility has been built in accordance with design. While a thorough commission testing program would include, either directly or indirectly, the verification of all those Protection System attributes addressed by the maintenance activities specified in the Tables of PRC-005-6, verification of the adequacy of initial installation necessitates the performance of testing and inspections that go well beyond these routine maintenance activities. For example, commission testing might set baselines for future tests; perform acceptance tests and/or warranty tests; utilize testing methods that are not generally done routinely like staged-Fault-tests.

However, many of the Protection System attributes which are verified during commission testing are not subject to age related or service related degradation, and need not be re-verified within an ongoing maintenance program. Example--it is not necessary to re-verify correct terminal strip wiring on an ongoing basis.

PRC-005-6 assumes that thorough commission testing was performed prior to a Protection System being placed in service. PRC-005-6 requires performance of maintenance activities that are deemed necessary to detect and correct plausible age and service related degradation of components, such that a properly built and commission tested Protection System will continue to function as designed over its service life.

It should be noted that commission testing frequently is performed by a different organization than that which is responsible for the ongoing maintenance of the Protection System. Furthermore, the commission testing activities will not necessarily correlate directly with the maintenance activities required by the standard. As such, it is very likely that commission testing records will deviate significantly from maintenance records in both form and content; and, therefore, it is not necessary to maintain commission testing records within the maintenance program documentation.

Notwithstanding the differences in records, an entity would be wise to retain commissioning records to show a maintenance start date. (See below). An entity that requires that their commissioning tests have, at a minimum, the requirements of PRC-005-6 would help that entity prove time interval maximums by setting the initial time clock.

How do you determine the initial due date for maintenance?

The initial due date for maintenance should be based upon when a Protection System was tested. Alternatively, an entity may choose to use the date of completion of the commission testing of the Protection System component and the system was placed into service as the starting point in determining its first maintenance due dates. Whichever method is chosen, for newly installed Protection Systems the components should not be placed into service until minimum maintenance activities have taken place.

It is conceivable that there can be a (substantial) difference in time between the date of testing, as compared to the date placed into service. The use of the "Calendar Year" language can help determine the next due date without too much concern about being non-compliant for missing test dates by a small amount (provided your dates are not already at the end of a year). However, if there is a substantial amount of time difference between testing and in-service dates, then the

testing date should be followed because it is the degradation of components that is the concern. While accuracy fluctuations may decrease when components are not energized, there are cases when degradation can take place, even though the device is not energized. Minimizing the time between commissioning tests and in-service dates will help.

If I miss two battery inspections four times out of 100 Protection System components on my transmission system, does that count as 2% or 8% when counting Violation Severity Level (VSL) for R3?

The entity failed to complete its scheduled program on two of its 100 Protection System components, which would equate to 2% for application to the VSL Table for Requirement R3. This VSL is written to compare missed components to total components. In this case two components out of 100 were missed, or 2%.

How do I achieve a “grace period” without being out of compliance?

The objective here is to create a time extension within your own PSMP that still does not violate the maximum time intervals stated in the standard. Remember that the maximum time intervals listed in the Tables cannot be extended.

For the purposes of this example, concentrating on just unmonitored protective relays – Table 1-1 specifies a maximum time interval (between the mandated maintenance activities) of six calendar years. Your plan must ensure that your unmonitored relays are tested at least once every six calendar years. You could, within your PSMP, require that your unmonitored relays be tested every four calendar years, with a maximum allowable time extension of 18 calendar months. This allows an entity to have deadlines set for the auto-generation of work orders, but still has the flexibility in scheduling complex work schedules. This also allows for that 18 calendar months to act as a buffer, in effect a grace period within your PSMP, in the event of unforeseen events. You will note that this example of a maintenance plan interval has a planned time of four years; it also has a built-in time extension allowed within the PSMP, and yet does not exceed the maximum time interval allowed by the standard. So while there are no time extensions allowed beyond the standard, an entity can still have substantial flexibility to maintain their Protection System components.

8.3 Basis for Table 1 Intervals

When developing the original *Protection System Maintenance – A Technical Reference* in 2007, the SPCTF collected all available data from Regional Entities (REs) on time intervals recommended for maintenance and test programs. The recommendations vary widely in categorization of relays, defined maintenance actions, and time intervals, precluding development of intervals by averaging. The SPCTF also reviewed the 2005 Report [2] of the IEEE Power System Relaying Committee Working Group I-17 (Transmission Relay System Performance Comparison). Review of the I-17 report shows data from a small number of utilities, with no company identification or means of investigating the significance of particular results.

To develop a solid current base of practice, the SPCTF surveyed its members regarding their maintenance intervals for electromechanical and microprocessor relays, and asked the members to also provide definitively-known data for other entities. The survey represented 470 GW of peak Load, or 4% of the NERC peak Load. Maintenance interval averages were compiled by weighting reported intervals according to the size (based on peak Load) of the reporting

utility. Thus, the averages more accurately represent practices for the large populations of Protection Systems used across the NERC regions.

The results of this survey with weighted averaging indicate maintenance intervals of five years for electromechanical or solid state relays, and seven years for unmonitored microprocessor relays.

A number of applicable entities have extended maintenance intervals for microprocessor relays beyond seven years, based on favorable experience with the particular products they have installed. To provide a technical basis for such extension, the SPCTF authors developed a recommendation of 10 years using the Markov modeling approach from [1], as summarized in Section 8.4. The results of this modeling depend on the completeness of self-testing or monitoring. Accordingly, this extended interval is allowed by Table 1, only when such relays are monitored as specified in the attributes of monitoring contained in Tables 1-1 through 1-5 and Table 2. Monitoring is capable of reporting Protection System health issues that are likely to affect performance within the 10 year time interval between verifications.

It is important to note that, according to modeling results, Protection System availability barely changes as the maintenance interval is varied below the 10-year mark. Thus, reducing the maintenance interval does not improve Protection System availability. With the assumptions of the model regarding how maintenance is carried out, reducing the maintenance interval actually degrades Protection System availability.

8.4 Basis for Extended Maintenance Intervals for Microprocessor Relays

Table 1 allows maximum verification intervals that are extended based on monitoring level. The industry has experience with self-monitoring microprocessor relays that leads to the Table 1 value for a monitored relay, as explained in Section 8.3. To develop a basis for the maximum interval for monitored relays in their *Protection System Maintenance – A Technical Reference*, the SPCTF used the methodology of Reference [1], which specifically addresses optimum routine maintenance intervals. The Markov modeling approach of [1] is judged to be valid for the design and typical failure modes of microprocessor relays.

The SPCTF authors ran test cases of the Markov model to calculate two key probability measures:

- Relay Unavailability - the probability that the relay is out of service due to failure or maintenance activity while the power system Element to be protected is in service.
- Abnormal Unavailability - the probability that the relay is out of service due to failure or maintenance activity when a Fault occurs, leading to failure to operate for the Fault.

The parameter in the Markov model that defines self-monitoring capability is ST (for self-test). ST = 0 if there is no self-monitoring; ST = 1 for full monitoring. Practical ST values are estimated to range from .75 to .95. The SPCTF simulation runs used constants in the Markov model that were the same as those used in [1] with the following exceptions:

Sn, Normal tripping operations per hour = 21600 (reciprocal of normal Fault clearing time of 10 cycles)

Sb, Backup tripping operations per hour = 4320 (reciprocal of backup Fault clearing time of 50 cycles)

Rc, Protected component repairs per hour = 0.125 (8 hours to restore the power system)

Rt, Relay routine tests per hour = 0.125 (8 hours to test a Protection System)

Rr, Relay repairs per hour = 0.08333 (12 hours to complete a Protection System repair after failure)

Experimental runs of the model showed low sensitivity of optimum maintenance interval to these parameter adjustments.

The resulting curves for relay unavailability and abnormal unavailability versus maintenance interval showed a broad minimum (optimum maintenance interval) in the vicinity of 10 years – the curve is flat, with no significant change in either unavailability value over the range of 9, 10, or 11 years. This was true even for a relay mean time between Failures (MTBF) of 50 years, much lower than MTBF values typically published for these relays. Also, the Markov modeling indicates that both the relay unavailability and abnormal unavailability actually become higher with more frequent testing. This shows that the time spent on these more frequent tests yields no failure discoveries that approach the negative impact of removing the relays from service and running the tests.

The PSMT SDT discussed the practical need for “time-interval extensions” or “grace periods” to allow for scheduling problems that resulted from any number of business contingencies. The time interval discussions also focused on the need to reflect industry norms surrounding Generator outage frequencies. Finally, it was again noted that FERC Order 693 demanded maximum time intervals. “Maximum time intervals” by their very term negates any “time-interval extension” or “grace periods.” To recognize the need to follow industry norms on Generator outage frequencies and accommodate a form of time-interval extension, while still following FERC Order 693, the Standard Drafting Team arrived at a six-year interval for the electromechanical relay, instead of the five-year interval arrived at by the SPCTF. The PSMT SDT has followed the FERC directive for a *maximum* time interval and has determined that no extensions will be allowed. Six years has been set for the maximum time interval between manual maintenance activities. This maximum time interval also works well for maintenance cycles that have been in use in generator plants for decades.

For monitored relays, the PSMT SDT notes that the SPCTF called for 10 years as the interval between maintenance activities. This 10-year interval was chosen, even though there was “...no significant change in unavailability value over the range of 9, 10, or 11 years. This was true even for a relay Mean Time between Failures (MTBF) of 50 years...” The Standard Drafting Team again sought to align maintenance activities with known successful practices and outage schedules. The Standard does not allow extensions on any component of the Protection System; thus, the maximum allowed interval for these components has been set to 12 years. Twelve years also fits well into the traditional maintenance cycles of both substations and generator plants.

Also of note is the Table’s use of the term “Calendar” in the column for “Maximum Maintenance Interval.” The PSMT SDT deemed it necessary to include the term “Calendar” to facilitate annual maintenance planning, scheduling and implementation. This need is the result of known occurrences of system requirements that could cause maintenance schedules to be missed by a few days or weeks. The PSMT SDT chose the term “Calendar” to preclude the need to have schedules be met to the day. An electromechanical protective relay that is maintained in year number one need not be revisited until six years later (year number seven). For example, a relay

was maintained April 10, 2008; maintenance would need to be completed no later than December 31, 2014.

Though not a requirement of this standard, to stay in line with many Compliance Enforcement Agencies audit processes an entity should define, within their own PSMP, the entity's use of terms like annual, calendar year, etc. Then, once this is within the PSMP, the entity should abide by their chosen language.

9. Performance-Based Maintenance Process

In lieu of using the Table 1 intervals, a Performance-Based Maintenance process may be used to establish maintenance intervals (*PRC-005 Attachment A Criteria for a Performance-Based Protection System Maintenance Program*). A Performance-Based Maintenance process may justify longer maintenance intervals, or require shorter intervals relative to Table 1. In order to use a Performance-Based Maintenance process, the documented maintenance program must include records of repairs, adjustments, and corrections to covered Protection Systems in order to provide historical justification for intervals, other than those established in Table 1. Furthermore, the asset owner must regularly analyze these records of corrective actions to develop a ranking of causes. Recurrent problems are to be highlighted, and remedial action plans are to be documented to mitigate or eliminate recurrent problems.

Entities with Performance-Based Maintenance track performance of Protection Systems, demonstrate how they analyze findings of performance failures and aberrations, and implement continuous improvement actions. Since no maintenance program can ever guarantee that no malfunction can possibly occur, documentation of a Performance-Based Maintenance program would serve the utility well in explaining to regulators and the public a Misoperation leading to a major System outage event.

A Performance-Based Maintenance program requires auditing processes like those included in widely used industrial quality systems (such as *ISO 9001-2000, Quality Management Systems – Requirements*; or applicable parts of the NIST Baldrige National Quality Program). The audits periodically evaluate:

- The completeness of the documented maintenance process
- Organizational knowledge of and adherence to the process
- Performance metrics and documentation of results
- Remediation of issues
- Demonstration of continuous improvement.

In order to opt into a Performance-Based Maintenance (PBM) program, the asset owner must first sort the various Components into population segments. Any population segment must be comprised of at least 60 individual units; if any asset owner opts for PBM, but does not own 60 units to comprise a population, then that asset owner may combine data from other asset owners until the needed 60 units is aggregated. Each population segment must be composed of a grouping of Components of a consistent design standard or particular model or type from a single manufacturer and subjected to similar environmental factors. For example: One segment cannot be comprised of both GE & Westinghouse electro-mechanical lock-out relays; likewise, one segment cannot be comprised of 60 GE lock-out relays, 30 of which are in a dirty environment, and the remaining 30 from a clean environment. This PBM process cannot be applied to batteries, but can be applied to all other Components, including (but not limited to) specific battery chargers, instrument transformers, trip coils and/or control circuitry (etc.).

9.1 Minimum Sample Size

Large Sample Size

An assumption that needs to be made when choosing a sample size is “the sampling distribution of the sample mean can be approximated by a normal probability distribution.” The Central Limit Theorem states: “In selecting simple random samples of size n from a population, the sampling distribution of the sample mean \bar{x} can be approximated by a normal probability distribution as the sample size becomes large.” (Essentials of Statistics for Business and Economics, Anderson, Sweeney, Williams, 2003.)

To use the Central Limit Theorem in statistics, the population size should be large. The references below are supplied to help define what is large.

“... whenever we are using a large simple random sample (rule of thumb: $n \geq 30$), the central limit theorem enables us to conclude that the sampling distribution of the sample mean can be approximated by a normal distribution.” (Essentials of Statistics for Business and Economics, Anderson, Sweeney, Williams, 2003.)

“If samples of size n , when $n \geq 30$, are drawn from any population with a mean μ and a standard deviation σ , the sampling distribution of sample means approximates a normal distribution. The greater the sample size, the better the approximation.” (Elementary Statistics - Picturing the World, Larson, Farber, 2003.)

“The sample size is large (generally $n \geq 30$)... (Introduction to Statistics and Data Analysis - Second Edition, Peck, Olson, Devore, 2005.)

“... the normal is often used as an approximation to the t distribution in a test of a null hypothesis about the mean of a normally distributed population when the population variance is estimated from a relatively large sample. A sample size exceeding 30 is often given as a minimal size in this connection.” (Statistical Analysis for Business Decisions, Peters, Summers, 1968.)

Error of Distribution Formula

Beyond the large sample size discussion above, a sample size requirement can be estimated using the bound on the Error of Distribution Formula when the expected result is of a “Pass/Fail” format and will be between 0 and 1.0.

The Error of Distribution Formula is:

$$B = z \sqrt{\frac{\pi(1-\pi)}{n}}$$

Where:

B = bound on the error of distribution (allowable error)

z = standard error

π = expected failure rate

n = sample size required

Solving for n provides:

$$n = \pi(1 - \pi) \left(\frac{z}{B} \right)^2$$

Minimum Population Size to use Performance-Based Program

One entity's population of components should be large enough to represent a sizeable sample of a vendor's overall population of manufactured devices. For this reason, the following assumptions are made:

$$B = 5\%$$

$$z = 1.96 \text{ (This equates to a 95\% confidence level)}$$

$$\pi = 4\%$$

Using the equation above, $n=59.0$.

Minimum Sample Size to evaluate Performance-Based Program

The number of components that should be included in a sample size for evaluation of the appropriate testing interval can be smaller because a lower confidence level is acceptable since the sample testing is repeated or updated annually. For this reason, the following assumptions are made:

$$B = 5\%$$

$$z = 1.44 \text{ (85\% confidence level)}$$

$$\pi = 4\%$$

Using the equation above, $n=31.8$.

Recommendation

Based on the above discussion, a sample size should be at least 30 to allow use of the equation mentioned. Using this and the results of the equation, the following numbers are recommended (and required within the standard):

Minimum Population Size to use Performance-Based Maintenance Program = 60

Minimum Sample Size to evaluate Performance-Based Program = 30.

Once the population segment is defined, then maintenance must begin within the intervals as outlined for the device described in the Tables 1-1 through 1-5. Time intervals can be lengthened provided the last years' worth of components tested (or the last 30 units maintained, whichever is more) had fewer than 4% Countable Events. It is notable that 4% is specifically chosen because an entity with a small population (30 units) would have to adjust its time intervals between maintenance if more than one Countable Event was found to have occurred during the last analysis period. A smaller percentage would require that entity to adjust the time interval between maintenance activities if even one unit is found out of tolerance or causes a Misoperation.

The minimum number of units that can be tested in any given year is 5% of the population. Note that this 5% threshold sets a practical limitation on total length of time between intervals at 20 years.

If at any time the number of Countable Events equals or exceeds 4% of the last year's tested components (or the last 30 units maintained, whichever is more), then the time period between manual maintenance activities must be decreased. There is a time limit on reaching the decreased time at which the Countable Events is less than 4%; this must be attained within three years.

Performance-Based Program Evaluation Example

The 4% performance target was derived as a protection system performance target and was selected based on the drafting team's experience and studies performed by several utilities. This is not derived from the performance of discrete devices. Microprocessor relays and electromechanical relays have different performance levels. It is not appropriate to compare these performance levels to each other. The performance of the segment should be compared to the 4% performance criteria.

In consideration of the use of Performance Based Maintenance (PBM), the user should consider the effects of extended testing intervals and the established 4% failure rate. In the table shown below, the segment is 1000 units. As the testing interval (in years) increases, the number of units tested each year decreases. The number of countable events allowed is 4% of the tested units. Countable events are the failure of a Component requiring repair or replacement, any corrective actions performed during the maintenance test on the units within the testing segment (units per year), or any Misoperation attributable to hardware failure or calibration failure found within the entire segment (1000 units) during the testing year.

Example: 1000 units in the segment with a testing interval of 8 years: The number of units tested each year will be 125 units. The total allowable countable events equals: $125 \times .04 = 5$. This number includes failure of a Component requiring repair or replacement, corrective issues found during testing, and the total number of Misoperations (attributable to hardware or calibration failure within the testing year) associated with the entire segment of 1000 units.

Example: 1000 units in the segment with a testing interval of 16 years: The number of units tested each year will be 63 units. The total allowable countable events equals: $63 \times .04 = 2.5$.

As shown in the above examples, doubling the testing interval reduces the number of allowable events by half.

Total number of units in the segment	1000
Failure rate	4.00%

Testing Intervals (Years)	Units Per Year	Acceptable Number of Countable Events per year	Yearly Failure Rate Based on 1000 Units in Segment
1	1000.00	40.00	4.00%
2	500.00	20.00	2.00%
4	250.00	10.00	1.00%
6	166.67	6.67	0.67%
8	125.00	5.00	0.50%
10	100.00	4.00	0.40%
12	83.33	3.33	0.33%
14	71.43	2.86	0.29%
16	62.50	2.50	0.25%
18	55.56	2.22	0.22%
20	50.00	2.00	0.20%

Using the prior year’s data, determine the maximum allowable maintenance interval for each Segment such that the Segment experiences Countable Events on no more than 4% of the Components within the Segment, for the greater of either the last 30 Components maintained or all Components maintained in the previous year.

Segment – Components of a consistent design standard, or a particular model or type from a single manufacturer that typically share other common elements. Consistent performance is expected across the entire population of a Segment. A Segment must contain at least sixty (60) individual Components.

Countable Event – A failure of a Component requiring repair or replacement, any condition discovered during the maintenance activities in Tables 1-1 through 1-5, Table 3, Table 4-1 through Table 4-3, and Table 5, which requires corrective action or a Protection System Misoperation attributed to hardware failure or calibration failure. Misoperations due to product design errors, software errors, relay settings different from specified settings, Protection System Component, Automatic Reclosing, or Sudden Pressure Relaying configuration or application errors are not included in Countable Events.

9.2 Frequently Asked Questions:

I’m a small entity and cannot aggregate a population of Protection System components to establish a segment required for a Performance-Based Protection System Maintenance Program. How can I utilize that opportunity?

Multiple asset owning entities may aggregate their individually owned populations of individual Protection System components to create a segment that crosses ownership boundaries. All entities participating in a joint program should have a single documented joint management process, with consistent Protection System Maintenance Programs (practices, maintenance intervals and criteria), for which the multiple owners are individually responsible with respect to the requirements of the Standard. The requirements established for Performance-Based Maintenance must be met for the overall aggregated program on an ongoing basis.

The aggregated population should reflect all factors that affect consistent performance across the population, including any relevant environmental factors such as geography, power-plant vs. substation, and weather conditions.

Can an owner go straight to a Performance-Based Maintenance program schedule, if they have previously gathered records?

Yes--an owner can go to a Performance-Based Maintenance program immediately. The owner will need to comply with the requirements of a Performance-Based Maintenance program as listed in the Standard. Gaps in the data collected will not be allowed; therefore, if an owner finds that a gap exists such that they cannot prove that they have collected the data as required for a Performance-Based Maintenance program then they will need to wait until they can prove compliance.

When establishing a Performance-Based Maintenance program, can I use test data from the device manufacturer, or industry survey results, as results to help establish a basis for my Performance-Based intervals?

No--you must use actual in-service test data for the components in the segment.

What types of Misoperations or events are not considered Countable Events in the Performance-Based Protection System Maintenance (PBM) Program?

Countable Events are intended to address conditions that are attributed to hardware failure or calibration failure; that is, conditions that reflect deteriorating performance of the component. These conditions include any condition where the device previously worked properly, then, due to changes within the device, malfunctioned or degraded to the point that re-calibration (to within the entity's tolerance) was required.

For this purpose of tracking hardware issues, human errors resulting in Protection System Misoperations during system installation or maintenance activities are not considered Countable Events. Examples of excluded human errors include relay setting errors, design errors, wiring errors, inadvertent tripping of devices during testing or installation, and misapplication of Protection System components. Examples of misapplication of Protection System components include wrong CT or PT tap position, protective relay function misapplication, and components not specified correctly for their installation. Obviously, if one is setting up relevant data about hardware failures then human failures should be eliminated from the hardware performance analysis.

One example of human-error is not pertinent data might be in the area of testing "86" lock-out relays (LOR). "Entity A" has two types of LOR's type "X" and type "Y"; they want to move into a performance based maintenance interval. They have 1000 of each type, so the population variables are met. During electrical trip testing of all of their various schemes over the initial six-year interval they find zero type "X" failures, but human error led to tripping a BES Element 100 times; they find 100 type "Y" failures and had an additional 100 human-error caused tripping incidents. In this example the human-error caused Misoperations should not be used to judge the performance of either type of LOR. Analysis of the data might lead "Entity A" to change time intervals. Type "X" LOR can be placed into extended time interval testing because of its low failure rate (zero failures) while Type "Y" would have to be tested more often than every 6 calendar years (100 failures divided by 1000 units exceeds the 4% tolerance level).

Certain types of Protection System component errors that cause Misoperations are not considered Countable Events. Examples of excluded component errors include device malfunctions that are correctable by firmware upgrades and design errors that do not impact protection function.

What are some examples of methods of correcting segment performance for Performance-Based Maintenance?

There are a number of methods that may be useful for correcting segment performance for mal-performing segments in a Performance-Based Maintenance system. Some examples are listed below.

- The maximum allowable interval, as established by the Performance-Based Maintenance system, can be decreased. This may, however, be slow to correct the performance of the segment.
- Identifiable sub-groups of components within the established segment, which have been identified to be the mal-performing portion of the segment, can be broken out as an independent segment for target action. Each resulting segment must satisfy the minimum population requirements for a Performance-Based Maintenance program in order to remain within the program.
- Targeted corrective actions can be taken to correct frequently occurring problems. An example would be replacement of capacitors within electromechanical distance relays if bad capacitors were determined to be the cause of the mal-performance.
- Components within the mal-performing segment can be replaced with other components (electromechanical distance relays with microprocessor relays, for example) to remove the mal-performing segment.

If I find (and correct) a Unresolved Maintenance Issue as a result of a Misoperation investigation (Re: PRC-004), how does this affect my Performance-Based Maintenance program?

If you perform maintenance on a Protection System component for any reason (including as part of a PRC-004 required Misoperation investigation/corrective action), the actions performed can count as a maintenance activity provided the activities in the relevant Tables have been done, and, if you desire, “reset the clock” on everything you’ve done. In a Performance-Based Maintenance program, you also need to record the Unresolved Maintenance Issue as a Countable Event within the relevant component group segment and use it in the analysis to determine your correct Performance-Based Maintenance interval for that component group. Note that “resetting the clock” should not be construed as interfering with an entity’s routine testing schedule because the “clock-reset” would actually make for a decreased time interval by the time the next routine test schedule comes around.

For example, a relay scheme, consisting of four relays, is tested on 1-1-11 and the PSMP has a time interval of 3 calendar years with an allowable extension of 1 calendar year. The relay would be due again for routine testing before the end of the year 2015. This hypothetical relay scheme has a Misoperation on 6-1-12 that points to one of the four relays as bad. Investigation proves a bad relay and a new one is tested and installed in place of the original. This replacement relay actually could be retested before the end of the year 2016 (clock-reset) and not be out of

compliance. This requires tracking maintenance by individual relays and is allowed. However, many companies schedule maintenance in other ways like by substation or by circuit breaker or by relay scheme. By these methods of tracking maintenance that “replaced relay” will be retested before the end of the year 2015. This is also acceptable. In no case was a particular relay tested beyond the PSMP of four years max, nor was the 6 year max of the Standard exceeded. The entity can reset the clock if they desire or the entity can continue with original schedules and, in effect, test even more frequently.

Why are batteries excluded from PBM? What about exclusion of batteries from condition based maintenance?

Batteries are the only element of a Protection System that is a perishable item with a shelf life. As a perishable item batteries require not only a constant float charge to maintain their freshness (charge), but periodic inspection to determine if there are problems associated with their aging process and testing to see if they are maintaining a charge or can still deliver their rated output as required.

Besides being perishable, a second unique feature of a battery that is unlike any other Protection System element, is that a battery uses chemicals, metal alloys, plastics, welds, and bonds that must interact with each other to produce the constant dc source required for Protection Systems, undisturbed by ac system Disturbances.

No type of battery manufactured today for Protection System application is free from problems of the sort that can only be detected over time by inspection and test. These problems can arise from variances in the manufacturing process, chemicals and alloys used in the construction of the individual cells, quality of welds and bonds to connect the components, the plastics used to make batteries, and the cell forming process for the individual battery cells.

Other problems that require periodic inspection and testing can result from transportation from the factory to the job site, length of time before a charge is put on the battery, the method of installation, the voltage level and duration of equalize charges, the float voltage level used, and the environment that the battery is installed in.

All of the above mentioned factors, as well as several more not discussed here, are beyond the control of the Functional Entities that want to use a Performance-Based Protection System Maintenance (PBM) program. Inherent variances in the aging process of a battery cell make establishment of a designated segment based on manufacturer and type of battery impossible.

The whole point of PBM is that if all variables are isolated then common aging and performance criteria would be the same. However, there are too many variables in the electrochemical process to completely isolate all of the performance-changing criteria.

Similarly, Functional Entities that want to establish a condition-based maintenance program using the highest levels of monitoring, resulting in the least amount of hands-on maintenance activity, cannot completely eliminate some periodic maintenance of the battery used in a station dc supply. Inspection of the battery is required on a Maximum Maintenance Interval listed in the tables due to the aging processes of station batteries. However, higher degrees of monitoring of a battery can eliminate the requirement for some periodic testing and some inspections (see Table 1-4).

Please provide an example of the calculations involved in extending maintenance time intervals using PBM.

Entity has 1000 GE-HEA lock-out relays; this is greater than the minimum sample requirement of 60. They start out testing all of the relays within the prescribed Table requirements (6 year max) by testing the relays every 5 years. The entity's plan is to test 200 units per year; this is greater than the minimum sample size requirement of 30. For the sake of example only the following will show 6 failures per year, reality may well have different numbers of failures every year. PBM requires annual assessment of failures found per units tested. After the first year of tests the entity finds 6 failures in the 200 units tested. $6/200 = 3\%$ failure rate. This entity is now allowed to extend the maintenance interval if they choose. The entity chooses to extend the maintenance interval of this population segment out to 10 years. This represents a rate of 100 units tested per year; entity selects 100 units to be tested in the following year. After that year of testing these 100 units the entity again finds 6 failed units. $6/100 = 6\%$ failures. This entity has now exceeded the acceptable failure rate for these devices and must accelerate testing of all of the units at a higher rate such that the failure rate is found to be less than 4% per year; the entity has three years to get this failure rate down to 4% or less (per year). In response to the 6% failure rate, the entity decreases the testing interval to 8 years. This means that they will now test 125 units per year ($1000/8$). The entity has just two years left to get the test rate corrected.

After a year, they again find six failures out of the 125 units tested. $6/125 = 5\%$ failures. In response to the 5% failure rate, the entity decreases the testing interval to seven years. This means that they will now test 143 units per year ($1000/7$). The entity has just one year left to get the test rate corrected. After a year, they again find six failures out of the 143 units tested. $6/143 = 4.2\%$ failures.

(Note that the entity has tried five years and they were under the 4% limit and they tried seven years and they were over the 4% limit. They must be back at 4% failures or less in the next year so they might simply elect to go back to five years.)

Instead, in response to the 5% failure rate, the entity decreases the testing interval to six years. This means that they will now test 167 units per year ($1000/6$). After a year, they again find six failures out of the 167 units tested. $6/167 = 3.6\%$ failures. Entity found that they could maintain the failure rate at no more than 4% failures by maintaining the testing interval at six years or less. Entity chose six-year interval and effectively extended their TBM (five years) program by 20%.

A note of practicality is that an entity will probably be in better shape to lengthen the intervals between tests if the failure rate is less than 2%. But the requirements allow for annual adjustments, if the entity desires. As a matter of maintenance management, an ever-changing test rate (units tested/year) may be un-workable.

Note that the "5% of components" requirement effectively sets a practical limit of 20 year maximum PBM interval. Also of note is the "3 years" requirement; an entity might arbitrarily extend time intervals from six years to 20 years. In the event that an entity finds a failure rate greater than 4%, then the test rate must be accelerated such that within three years the failure rate must be brought back down to 4% or less.

Here is a table that demonstrates the values discussed:

Year #	Total Population (P)	Test Interval (I)	Units to be Tested (U= P/I)	# of Failures Found (F)	Failure Rate (=F/U)	Decision to Change Interval Yes or No	Interval Chosen
1	1000	5 yrs	200	6	3%	Yes	10 yrs
2	1000	10 yrs	100	6	6%	Yes	8 yrs
3	1000	8 yrs	125	6	5%	Yes	7 yrs
4	1000	7 yrs	143	6	4.2%	Yes	6 yrs
5	1000	6 yrs	167	6	3.6%	No	6 yrs

Please provide an example of the calculations involved in extending maintenance time intervals using PBM for control circuitry.

Note that the following example captures “Control Circuitry” as all of the trip paths associated with a particular trip coil of a circuit breaker. An entity is not restricted to this method of counting control circuits. Perhaps another method an entity would prefer would be to simply track every individual (parallel) trip path. Or perhaps another method would be to track all of the trip outputs from a specific (set) of relays protecting a specific element.

The designation of what constitutes a control circuit component is very dependent upon how an entity performs and tracks the testing of the control circuitry. Some entities test their control circuits on a breaker basis whereas others test their circuitry on a local zone of protection basis. Thus, entities are allowed the latitude to designate their own definitions of control circuit components. Another example of where the entity has some discretion on determining what constitutes a single component is the voltage and current sensing devices, where the entity may choose either to designate a full three-phase set of such devices or a single device as a single component.

In Attachment A (PBM) the definition of Segment is:

Segment –*Components of a consistent design standard, or a particular model or type from a single manufacturer that typically share other common elements. Consistent performance is expected across the entire population of a segment. A segment must contain at least sixty (60) individual components.*

Example:

Entity has 1,000 circuit breakers, all of which have two trip coils, for a total of 2,000 trip coils; if all circuitry was designed and built with a consistent (internal entity) standard, then this is greater than the minimum sample requirement of 60.

For the sake of further example, the following facts are given:

Half of all relay panels (500) were built 40 years ago by an outside contractor, consisted of asbestos wrapped 600V-insulation panel wiring, and the cables exiting the control house are THHN pulled in conduit direct to exactly half of all of the various circuit breakers. All of the relay panels and cable pulls were built with consistent standards and consistent performance standard

expectations within the segment (which is greater than 60). Each relay panel has redundant microprocessor (MPC) relays (retrofitted); each MPC relay supplies an individual trip output to each of the two trip coils of the assigned circuit breaker.

Approximately 35 years ago, the entity developed their own internal construction crew and now builds all of their own relay panels from parts supplied from vendors that meet the entity's specifications, including SIS 600V insulation wiring and copper-sheathed cabling within the direct conduits to circuit breakers. The construction crew uses consistent standards in the construction. This newer segment of their control circuitry population is different than the original segment, consistent (standards, construction and performance expectations) within the new segment and constitutes the remainder of the entity's population (another 500 panels and the cabling to the remaining 500 circuit breakers). Each relay panel has redundant microprocessor (MPC) relays; each MPC relay supplies an individual trip output to each of the two trip coils of the assigned circuit breaker. Every trip path in this newer segment has a device that monitors the voltage directly across the trip contacts of the MPC relays and alarms via RTU and SCADA to the operations control room. This monitoring device, when not in alarm, demonstrates continuity all the way through the trip coil, cabling and wiring back to the trip contacts of the MPC relay.

The entity is tracking 2,000 trip coils (each consisting of multiple trip paths) in each of these two segments. But half of all of the trip paths are monitored; therefore, the trip paths are continuously tested and the circuit will alarm when there is a failure. These alarms have to be verified every 12 years for correct operation.

The entity now has 1,000 trip coils (and associated trip paths) remaining that they have elected to count as control circuits. The entity has instituted a process that requires the verification of every trip path to each trip coil (one unit), including the electrical activation of the trip coil. (The entity notes that the trip coils will have to be tripped electrically more often than the trip path verification, and is taking care of this activity through other documentation of Real-time Fault operations.)

They start out testing all of the trip coil circuits within the prescribed Table requirements (12-year max) by testing the trip circuits every 10 years. The entity's plan is to test 100 units per year; this is greater than the minimum sample size requirement of 30. For the sake of example only, the following will show three failures per year; reality may well have different numbers of failures every year. PBM requires annual assessment of failures found per units tested. After the first year of tests, the entity finds three failures in the 100 units tested. $3/100 = 3\%$ failure rate.

This entity is now allowed to extend the maintenance interval, if they choose. The entity chooses to extend the maintenance interval of this population segment out to 20 years. This represents a rate of 50 units tested per year; entity selects 50 units to be tested in the following year. After that year of testing these 50 units, the entity again finds three failed units. $3/50 = 6\%$ failures.

This entity has now exceeded the acceptable failure rate for these devices and must accelerate testing of all of the units at a higher rate, such that the failure rate is found to be less than 4% per year; the entity has three years to get this failure rate down to 4% or less (per year).

In response to the 6% failure rate, the entity decreases the testing interval to 16 years. This means that they will now test 63 units per year ($1000/16$). The entity has just two years left to get the

test rate corrected. After a year, they again find three failures out of the 63 units tested. $3/63 = 4.76\%$ failures.

In response to the $>4\%$ failure rate, the entity decreases the testing interval to 14 years. This means that they will now test 72 units per year ($1000/14$). The entity has just one year left to get the test rate corrected. After a year, they again find three failures out of the 72 units tested. $3/72 = 4.2\%$ failures.

(Note that the entity has tried 10 years, and they were under the 4% limit; and they tried 14 years, and they were over the 4% limit. They must be back at 4% failures or less in the next year, so they might simply elect to go back to 10 years.)

Instead, in response to the 4.2% failure rate, the entity decreases the testing interval to 12 years. This means that they will now test 84 units per year ($1000/12$). After a year, they again find three failures out of the 84 units tested. $3/84 = 3.6\%$ failures.

Entity found that they could maintain the failure rate at no more than 4% failures by maintaining the testing interval at 12 years or less. Entity chose 12-year interval, and effectively extended their TBM (10 years) program by 20%.

A note of practicality is that an entity will probably be in better shape to lengthen the intervals between tests if the failure rate is less than 2%. But the requirements allow for annual adjustments if the entity desires. As a matter of maintenance management, an ever-changing test rate (units tested / year) may be un-workable.

Note that the “5% of components” requirement effectively sets a practical limit of 20-year maximum PBM interval. Also of note is the “3 years” requirement; an entity might arbitrarily extend time intervals from six years to 20 years. In the event that an entity finds a failure rate greater than 4%, then the test rate must be accelerated such that within three years the failure rate must be brought back down to 4% or less.

Here is a table that demonstrates the values discussed:

Year #	Total Population (P)	Test Interval (I)	Units to be Tested (U= P/I)	# of Failures Found (F)	Failure Rate (=F/U)	Decision to Change Interval Yes or No	Interval Chosen
1	1000	10 yrs	100	3	3%	Yes	20 yrs
2	1000	20 yrs	50	3	6%	Yes	16yrs
3	1000	16 yrs	63	3	4.8%	Yes	14 yrs
4	1000	14 yrs	72	3	4.2%	Yes	12 yrs
5	1000	12 yrs	84	3	3.6%	No	12 yrs

Please provide an example of the calculations involved in extending maintenance time intervals using PBM for voltage and current sensing devices.

Note that the following example captures “voltage and current inputs to the protective relays” as all of the various current transformer and potential transformer signals associated with a particular set of relays used for protection of a specific Element. This entity calls this set of protective relays a “Relay Scheme.” Thus, this entity chooses to count PT and CT signals as a group instead of individually tracking maintenance activities to specific bushing CT’s or specific PT’s. An entity is not restricted to this method of counting voltage and current devices, signals and paths. Perhaps another method an entity would prefer would be to simply track every individual PT and CT. Note that a generation maintenance group may well select the latter because they may elect to perform routine off-line tests during generator outages, whereas a transmission maintenance group might create a process that utilizes Real-time system values measured at the relays.

The designation of what constitutes a control circuit component is very dependent upon how an entity performs and tracks the testing of the control circuitry. Some entities test their control circuits on a breaker basis whereas others test their circuitry on a local zone of protection basis. Thus, entities are allowed the latitude to designate their own definitions of control circuit components. Another example of where the entity has some discretion on determining what constitutes a single component is the voltage and current sensing devices, where the entity may choose either to designate a full three-phase set of such devices or a single device as a single component.

And in Attachment A (PBM) the definition of Segment:

Segment –*Components of a consistent design standard, or a particular model or type from a single manufacturer that typically share other common elements. Consistent performance is expected across the entire population of a segment. A segment must contain at least sixty (60) individual components.*

Example:

Entity has 2000 “Relay Schemes,” all of which have three current signals supplied from bushing CTs, and three voltage signals supplied from substation bus PT’s. All cabling and circuitry was designed and built with a consistent (internal entity) standard, and this population is greater than the minimum sample requirement of 60.

For the sake of further example the following facts are given:

Half of all relay schemes (1,000) are supplied with current signals from ANSI STD C800 bushing CTs and voltage signals from PTs built by ACME Electric MFR CO. All of the relay panels and cable pulls were built with consistent standards, and consistent performance standard expectations exist for the consistent wiring, cabling and instrument transformers within the segment (which is greater than 60).

The other half of the entity’s relay schemes have MPC relays with additional monitoring built-in that compare DNP values of voltages and currents (or watts and vars), as interpreted by the MPC relays and alarm for an entity-accepted tolerance level of accuracy. This newer segment of their “Voltage and Current Sensing” population is different than the original segment, consistent

(standards, construction and performance expectations) within the new segment and constitutes the remainder of the entity's population.

The entity is tracking many thousands of voltage and current signals within 2,000 relay schemes (each consisting of multiple voltage and current signals) in each of these two segments. But half of all of the relay schemes voltage and current signals are monitored; therefore, the voltage and current signals are continuously tested and the circuit will alarm when there is a failure; these alarms have to be verified every 12 years for correct operation.

The entity now has 1,000 relay schemes worth of voltage and current signals remaining that they have elected to count within their relay schemes designation. The entity has instituted a process that requires the verification of these voltage and current signals within each relay scheme (one unit).

(Please note - a problem discovered with a current or voltage signal found at the relay could be caused by anything from the relay, all the way to the signal source itself. Having many sources of problems can easily increase failure rates beyond the rate of failures of just one item (for example just PTs). It is the intent of the SDT to minimize failure rates of all of the equipment to an acceptable level; thus, any failure of any item that gets the signal from source to relay is counted. It is for this reason that the SDT chose to set the boundary at the ability of the signal to be delivered all the way to the relay.

The entity will start out measuring all of the relay scheme voltage and currents at the individual relays within the prescribed Table requirements (12 year max) by measuring the voltage and current values every 10 years. The entity's plan is to test 100 units per year; this is greater than the minimum sample size requirement of 30. For the sake of example only, the following will show three failures per year; reality may well have different numbers of failures every year. PBM requires annual assessment of failures found per units tested. After the first year of tests, the entity finds three failures in the 100 units tested. $3/100 = 3\%$ failure rate.

This entity is now allowed to extend the maintenance interval, if they choose. The entity chooses to extend the maintenance interval of this population segment out to 20 years. This represents a rate of 50 units tested per year; entity selects 50 units to be tested in the following year. After that year of testing these 50 units, the entity again finds three failed units. $3/50 = 6\%$ failures.

This entity has now exceeded the acceptable failure rate for these devices and must accelerate testing of all of the units at a higher rate, such that the failure rate is found to be less than 4% per year; the entity has three years to get this failure rate down to 4% or less (per year).

In response to the 6% failure rate, the entity decreases the testing interval to 16 years. This means that they will now test 63 units per year ($1000/16$). The entity has just two years left to get the test rate corrected. After a year, they again find three failures out of the 63 units tested. $3/63 = 4.76\%$ failures.

In response to the >4% failure rate, the entity decreases the testing interval to 14 years. This means that they will now test 72 units per year ($1000/14$). The entity has just one year left to get the test rate corrected. After a year, they again find three failures out of the 72 units tested. $3/72 = 4.2\%$ failures.

(Note that the entity has tried 10 years, and they were under the 4% limit; and they tried 14 years, and they were over the 4% limit. They must be back at 4% failures or less in the next year, so they might simply elect to go back to 10 years.)

Instead, in response to the 4.2% failure rate, the entity decreases the testing interval to 12 years. This means that they will now test 84 units per year (1,000/12). After a year, they again find three failures out of the 84 units tested. $3/84 = 3.6\%$ failures.

Entity found that they could maintain the failure rate at no more than 4% failures by maintaining the testing interval at 12 years or less. Entity chose 12-year interval and effectively extended their TBM (10 years) program by 20%.

A note of practicality is that an entity will probably be in better shape to lengthen the intervals between tests if the failure rate is less than 2%. But the requirements allow for annual adjustments, if the entity desires. As a matter of maintenance management, an ever-changing test rate (units tested/year) may be un-workable.

Note that the “5% of components” requirement effectively sets a practical limit of 20-year maximum PBM interval. Also of note is the “3 years” requirement; an entity might arbitrarily extend time intervals from six years to 20 years. In the event that an entity finds a failure rate greater than 4%, then the test rate must be accelerated such that within three years the failure rate must be brought back down to 4% or less.

Here is a table that demonstrates the values discussed:

Year #	Total Population (P)	Test Interval (I)	Units to be Tested (U= P/I)	# of Failures Found (F)	Failure Rate (=F/U)	Decision to Change Interval Yes or No	Interval Chose
1	1000	10 yrs	100	3	3%	Yes	20 yrs
2	1000	20 yrs	50	3	6%	Yes	16yrs
3	1000	16 yrs	63	3	4.8%	Yes	14 yrs
4	1000	14 yrs	72	3	4.2%	Yes	12 yrs
5	1000	12 yrs	84	3	3.6%	No	12 yrs

10. Overlapping the Verification of Sections of the Protection System

Tables 1-1 through 1-5 require that every Protection System component be periodically verified. One approach, but not the only method, is to test the entire protection scheme as a unit, from the secondary windings of voltage and current sources to breaker tripping. For practical ongoing verification, sections of the Protection System may be tested or monitored individually. The boundaries of the verified sections must overlap to ensure that there are no gaps in the verification. See Appendix A of this Supplementary Reference for additional discussion on this topic.

All of the methodologies expressed within this report may be combined by an entity, as appropriate, to establish and operate a maintenance program. For example, a Protection System may be divided into multiple overlapping sections with a different maintenance methodology for each section:

- Time-based maintenance with appropriate maximum verification intervals for categories of equipment, as given in the Tables 1-1 through 1-5;
- Monitoring as described in Tables 1-1 through 1-5;
- A Performance-Based Maintenance program as described in Section 9 above, or Attachment A of the standard;
- Opportunistic verification using analysis of Fault records, as described in Section 11

10.1 Frequently Asked Questions:

My system has alarms that are gathered once daily through an auto-polling system; this is not really a conventional SCADA system but does it meet the Table 1 requirements for inclusion as a monitored system?

Yes--provided the auto-polling that gathers the alarms reports those alarms to a location where the action can be initiated to correct the Unresolved Maintenance Issue. This location does not have to be the location of the engineer or the technician that will eventually repair the problem, but rather a location where the action can be initiated.

11. Monitoring by Analysis of Fault Records

Many users of microprocessor relays retrieve Fault event records and oscillographic records by data communications after a Fault. They analyze the data closely if there has been an apparent Misoperation, as NERC standards require. Some advanced users have commissioned automatic Fault record processing systems that gather and archive the data. They search for evidence of component failures or setting problems hidden behind an operation whose overall outcome seems to be correct. The relay data may be augmented with independently captured Digital Fault Recorder (DFR) data retrieved for the same event.

Fault data analysis comprises a legitimate CBM program that is capable of reducing the need for a manual time-interval based check on Protection Systems whose operations are analyzed. Even electromechanical Protection Systems instrumented with DFR channels may achieve some CBM benefit. The completeness of the verification then depends on the number and variety of Faults in the vicinity of the relay that produce relay response records and the specific data captured.

A typical Fault record will verify particular parts of certain Protection Systems in the vicinity of the Fault. For a given Protection System installation, it may or may not be possible to gather within a reasonable amount of time an ensemble of internal and external Fault records that completely verify the Protection System.

For example, Fault records may verify that the particular relays that tripped are able to trip via the control circuit path that was specifically used to clear that Fault. A relay or DFR record may indicate correct operation of the protection communications channel. Furthermore, other nearby Protection Systems may verify that they restrain from tripping for a Fault just outside their respective zones of protection. The ensemble of internal Fault and nearby external Fault event data can verify major portions of the Protection System, and reset the time clock for the Table 1 testing intervals for the verified components only.

What can be shown from the records of one operation is very specific and limited. In a panel with multiple relays, only the specific relay(s) whose operation can be observed without ambiguity should be used. Be careful about using Fault response data to verify that settings or calibration are correct. Unless records have been captured for multiple Faults close to either side of a setting boundary, setting or calibration could still be incorrect.

PMU data, much like DME data, can be utilized to prove various components of the Protection System. Obviously, care must be taken to attribute proof only to the parts of a Protection System that can actually be proven using the PMU or DME data.

If Fault record data is used to show that portions or all of a Protection System have been verified to meet Table 1 requirements, the owner must retain the Fault records used, and the maintenance-related conclusions drawn from this data and used to defer Table 1 tests, for at least the retention time interval given in Section 8.2.

11.1 Frequently Asked Questions:

I use my protective relays for Fault and Disturbance recording, collecting oscillographic records and event records via communications for Fault analysis to meet NERC and DME requirements. What are the maintenance requirements for the relays?

For relays used only as Disturbance Monitoring Equipment, NERC Standard PRC-018-1 R3 & R6 states the maintenance requirements and is being addressed by a standards activity that is revising PRC-002-1 and PRC-018-1. For protective relays “that are designed to provide protection for the BES,” this standard applies, even if they also perform DME functions.

12. Importance of Relay Settings in Maintenance Programs

In manual testing programs, many utilities depend on pickup value or zone boundary tests to show that the relays have correct settings and calibration. Microprocessor relays, by contrast, provide the means for continuously monitoring measurement accuracy. Furthermore, the relay digitizes inputs from one set of signals to perform all measurement functions in a single self-monitoring microprocessor system. These relays do not require testing or calibration of each setting.

However, incorrect settings may be a bigger risk with microprocessor relays than with older relays. Some microprocessor relays have hundreds or thousands of settings, many of which are critical to Protection System performance.

Monitoring does not check measuring element settings. Analysis of Fault records may or may not reveal setting problems. To minimize risk of setting errors after commissioning, the user should enforce strict settings data base management, with reconfirmation (manual or automatic) that the installed settings are correct whenever maintenance activity might have changed them; for background and guidance, see [5] in References.

Table 1 requires that settings must be verified to be as specified. The reason for this requirement is simple: With legacy relays (non-microprocessor protective relays), it is necessary to know the value of the intended setting in order to test, adjust and calibrate the relay. Proving that the relay works per specified setting was the de facto procedure. However, with the advanced microprocessor relays, it is possible to change relay settings for the purpose of verifying specific functions and then neglect to return the settings to the specified values. While there is no specific requirement to maintain a settings management process, there remains a need to verify that the settings left in the relay are the intended, specified settings. This need may manifest itself after any of the following:

- One or more settings are changed for any reason.
- A relay fails and is repaired or replaced with another unit.
- A relay is upgraded with a new firmware version.

12.1 Frequently Asked Questions:

How do I approach testing when I have to upgrade firmware of a microprocessor relay?

The entity should ensure that the relay continues to function properly after implementation of firmware changes. Some entities may have a Research and Development (R&D) department that might routinely run acceptance tests on devices with firmware upgrades before allowing the upgrade to be installed. Other entities may rely upon the vigorous testing of the firmware OEM. An entity has the latitude to install devices and/or programming that they believe will perform to their satisfaction. If an entity should choose to perform the maintenance activities specified in the Tables following a firmware upgrade, then they may, if they choose, reset the time clock on that set of maintenance activities so that they would not have to repeat the maintenance on

its regularly scheduled cycle. (However, for simplicity in maintenance schedules, some entities may choose to not reset this time clock; it is merely a suggested option.)

If I upgrade my old relays, then do I have to maintain my previous equipment maintenance documentation?

If an equipment item is repaired or replaced, then the entity can restart the maintenance-activity-time-interval-clock, if desired; however, the replacement of equipment does not remove any documentation requirements. The requirements in the standard are intended to ensure that an entity has a maintenance plan, and that the entity adheres to minimum activities and maximum time intervals. The documentation requirements are intended to help an entity demonstrate compliance. For example, saving the dates and records of the last two maintenance activities is intended to demonstrate compliance with the interval. Therefore, if you upgrade or replace equipment, then you still must maintain the documentation for the previous equipment, thus demonstrating compliance with the time interval requirement prior to the replacement action.

We have a number of installations where we have changed our Protection System components. Some of the changes were upgrades, but others were simply system rating changes that merely required taking relays “out-of-service”. What are our responsibilities when it comes to “out-of-service” devices?

Assuming that your system up-rates, upgrades and overall changes meet any and all other requirements and standards, then the requirements of PRC-005-6 are simple – if the Protection System component performs a Protection System function, then it must be maintained. If the component no longer performs Protection System functions, then it does not require maintenance activities under the Tables of PRC-005-6. While many entities might physically remove a component that is no longer needed, there is no requirement in PRC-005-6 to remove such component(s). Obviously, prudence would dictate that an “out-of-service” device is truly made inactive. There are no record requirements listed in PRC-005-6 for Protection System components not used.

While performing relay testing of a protective device on our Bulk Electric System, it was discovered that the protective device being tested was either broken or out of calibration. Does this satisfy the relay testing requirement, even though the protective device tested bad, and may be unable to be placed back into service?

Yes, PRC-005-6 requires entities to perform relay testing on protective devices on a given maintenance cycle interval. By performing this testing, the entity has satisfied PRC-005-6 requirement, although the protective device may be unable to be returned to service under normal calibration adjustments. Requirement R5 states:

“R5. Each Transmission Owner, Generator Owner, and Distribution Provider shall demonstrate efforts to correct any identified Unresolved Maintenance Issues.”

Also, when a failure occurs in a Protection System, power system security may be comprised, and notification of the failure must be conducted in accordance with relevant NERC standards.

If I show the protective device out of service while it is being repaired, then can I add it back as a new protective device when it returns? If not, my relay testing history would show that I was out of compliance for the last maintenance cycle.

The maintenance and testing requirements (Requirement R5) state “...shall demonstrate efforts to correct any identified Unresolved Maintenance Issues...” The type of corrective activity is not stated; however, it could include repairs or replacements.

Your documentation requirements will increase, of course, to demonstrate that your device tested bad and had corrective actions initiated. Your regional entity might ask about the status of your corrective actions.

13. Self-Monitoring Capabilities and Limitations

Microprocessor relay proponents have cited the self-monitoring capabilities of these products for nearly 20 years. Theoretically, any element that is monitored does not need a periodic manual test. A problem today is that the community of manufacturers and users has not created clear documentation of exactly what is and is not monitored. Some unmonitored but critical elements are buried in installed systems that are described as self-monitoring.

To utilize the extended time intervals allowed by monitoring, the user must document that the monitoring attributes of the device match the minimum requirements listed in the Table 1.

Until users are able to document how all parts of a system which are required for the protective functions are monitored or verified (with help from manufacturers), they must continue with the unmonitored intervals established in Tables 1, 3, 4 and 5 and any associated sub-tables.

Going forward, manufacturers and users can develop mappings of the monitoring within relays, and monitoring coverage by the relay of user circuits connected to the relay terminals.

To enable the use of the most extensive monitoring (and never again have a hands-on maintenance requirement), the manufacturers of the microprocessor-based self-monitoring components in the Protection System should publish for the user a document or map that shows:

- How all internal elements of the product are monitored for any failure that could impact Protection System performance.
- Which connected circuits are monitored by checks implemented within the product; how to connect and set the product to assure monitoring of these connected circuits; and what circuits or potential problems are not monitored.

This manufacturer's information can be used by the registered entity to document compliance of the monitoring attributes requirements by:

- Presenting or referencing the product manufacturer's documents.
- Explaining in a system design document the mapping of how every component and circuit that is critical to protection is monitored by the microprocessor product(s) or by other design features.
- Extending the monitoring to include the alarm transmission Facilities through which failures are reported within a given time frame to allocate where action can be taken to initiate resolution of the alarm attributed to an Unresolved Maintenance Issue, so that failures of monitoring or alarming systems also lead to alarms and action.
- Documenting the plans for verification of any unmonitored components according to the requirements of Tables 1, 3, 4 and 5 and any associated sub-tables.

13.1 Frequently Asked Questions:

I can't figure out how to demonstrate compliance with the requirements for the highest level of monitoring of Protection Systems. Why does this Maintenance Standard describe a maintenance program approach I cannot achieve?

Demonstrating compliance with the requirements for the highest level of monitoring any particular component of Protection Systems is likely to be very involved, and may include detailed manufacturer documentation of complete internal monitoring within a device, comprehensive design drawing reviews, and other detailed documentation. This standard does not presume to specify what documentation must be developed; only that it must be documented.

There may actually be some equipment available that is capable of meeting these highest levels of monitoring criteria, in which case it may be maintained according to the highest level of monitoring shown on the Tables. However, even if there is no equipment available today that can meet this level of monitoring, the standard establishes the necessary requirements for when such equipment becomes available.

By creating a roadmap for development, this provision makes the standard technology-neutral. The Standard Drafting Team wants to avoid the need to revise the standard in a few years to accommodate technology advances that may be coming to the industry.

14. Notification of Protection System or Automatic Reclosing Failures

When a failure occurs in a Protection System or Automatic Reclosing, power system security may be compromised, and notification of the failure must be conducted in accordance with relevant NERC standard(s). Knowledge of the failure may impact the system operator's decisions on acceptable Loading conditions.

This formal reporting of the failure and repair status to the system operator by the Protection System or Automatic Reclosing owner also encourages the system owner to execute repairs as rapidly as possible. In some cases, a microprocessor relay or carrier set can be replaced in hours; wiring termination failures may be repaired in a similar time frame. On the other hand, a component in an electromechanical or early-generation electronic relay may be difficult to find and may hold up repair for weeks. In some situations, the owner may have to resort to a temporary protection panel, or complete panel replacement.

15. Maintenance Activities

Some specific maintenance activities are a requirement to ensure reliability. An example would be that a BES entity could be prudent in its protective relay maintenance, but if its battery maintenance program is lacking, then reliability could still suffer. The NERC glossary outlines a Protection System as containing specific components. PRC-005-6 requires specific maintenance activities be accomplished within a specific time interval. As noted previously, higher technology equipment can contain integral monitoring capability that actually performs maintenance verification activities routinely and often; therefore, *manual intervention* to perform certain activities on these type components may not be needed.

15.1 Protective Relays (Table 1-1)

These relays are defined as the devices that receive the input signal from the current and voltage sensing devices and are used to isolate a Faulted Element of the BES. Devices that sense thermal, vibration, seismic, gas, or any other non-electrical inputs are excluded.

Non-microprocessor based equipment is treated differently than microprocessor-based equipment in the following ways; the relays should meet the asset owners' tolerances:

- Non-microprocessor devices must be tested with voltage and/or current applied to the device.
- Microprocessor devices may be tested through the integral testing of the device.
 - There is no specific protective relay commissioning test or relay routine test mandated.
 - There is no specific documentation mandated.

15.1.1 Frequently Asked Questions:

What calibration tolerance should be applied on electromechanical relays?

Each entity establishes their own acceptable tolerances when applying protective relaying on their system. For some Protection System components, adjustment is required to bring measurement accuracy within the parameters established by the asset owner based on the specific application of the component. A calibration failure is the result if testing finds the specified parameters to be out of tolerance.

15.2 Voltage & Current Sensing Devices (Table 1-3)

These are the current and voltage sensing devices, usually known as instrument transformers. There is presently a technology available (fiber-optic Hall-effect) that does not utilize conventional transformer technology; these devices and other technologies that produce quantities that represent the primary values of voltage and current are considered to be a type of voltage and current sensing devices included in this standard.

The intent of the maintenance activity is to verify the input to the protective relay from the device that produces the current or voltage signal sample.

There is no specific test mandated for these components. The important thing about these signals is to know that the expected output from these components actually reaches the protective relay. Therefore, the proof of the proper operation of these components also demonstrates the integrity of the wiring (or other medium used to convey the signal) from the current and voltage sensing device, all the way to the protective relay. The following observations apply:

- There is no specific ratio test, routine test or commissioning test mandated.
- There is no specific documentation mandated.
- It is required that the signal be present at the relay.
- This expectation can be arrived at from any of a number of means; including, but not limited to, the following: By calculation, by comparison to other circuits, by commissioning tests, by thorough inspection, or by any means needed to verify the circuit meets the asset owner's Protection System maintenance program.
- An example of testing might be a saturation test of a CT with the test values applied at the relay panel; this, therefore, tests the CT, as well as the wiring from the relay all the back to the CT.
- Another possible test is to measure the signal from the voltage and/or current sensing devices, during Load conditions, at the input to the relay.
- Another example of testing the various voltage and/or current sensing devices is to query the microprocessor relay for the Real-time Loading; this can then be compared to other devices to verify the quantities applied to this relay. Since the input devices have supplied the proper values to the protective relay, then the verification activity has been satisfied. Thus, event reports (and oscillographs) can be used to verify that the voltage and current sensing devices are performing satisfactorily.
- Still another method is to measure total watts and vars around the entire bus; this should add up to zero watts and zero vars, thus proving the voltage and/or current sensing devices system throughout the bus.
- Another method for proving the voltage and/or current-sensing devices is to complete commissioning tests on all of the transformers, cabling, fuses and wiring.
- Any other method that verifies the input to the protective relay from the device that produces the current or voltage signal sample.

15.2.1 Frequently Asked Questions:

What is meant by "...verify the current and voltage circuit inputs from the voltage and current sensing devices to the protective relays ..." Do we need to perform ratio, polarity and saturation tests every few years?

No--you must verify that the protective relay is receiving the expected values from the voltage and current-sensing devices (typically voltage and current transformers). This can be as difficult as is proposed by the question (with additional testing on the cabling and substation wiring to ensure that the values arrive at the relays); or simplicity can be achieved by other verification methods. While some examples follow, these are not intended to represent an all-inclusive list; technology advances and ingenuity should not be excluded from making comparisons and verifications:

- Compare the secondary values, at the relay, to a metering circuit, fed by different current transformers, monitoring the same line as the questioned relay circuit.
- Compare the individual phase secondary values at the relay panel (with additional testing on the panel wiring to ensure that the values arrive at those relays) with the other phases, and verify that residual currents are within expected bounds.
- Observe all three phase currents and the residual current at the relay panel with an oscilloscope, observing comparable magnitudes and proper phase relationship, with additional testing on the panel wiring to ensure that the values arrive at the relays.
- Compare the values, as determined by the questioned relay (such as, but not limited to, a query to the microprocessor relay) to another protective relay monitoring the same line, with currents supplied by different CTs.
- Compare the secondary values, at the relay with values measured by test instruments (such as, but not limited to multi-meters, voltmeter, clamp-on ammeters, etc.) and verified by calculations and known ratios to be the values expected. For example, a single PT on a 100 KV bus will have a specific secondary value that, when multiplied by the PT ratio, arrives at the expected bus value of 100 KV.
- Query SCADA for the power flows at the far end of the line protected by the questioned relay, compare those SCADA values to the values as determined by the questioned relay.
- Totalize the watts and vars on the bus and compare the totals to the values as seen by the questioned relay.

The point of the verification procedure is to ensure that all of the individual components are functioning properly; and that an ongoing proactive procedure is in place to re-check the various components of the protective relay measuring Systems.

Is wiring insulation or hi-pot testing required by this Maintenance Standard?

No--wiring insulation and equipment hi-pot testing are not specifically required by the Maintenance Standard. However, if the method of verifying CT and PT inputs to the relay involves some other method than actual observation of current and voltage transformer secondary inputs to the relay, it might be necessary to perform some sort of cable integrity test to verify that the instrument transformer secondary signals are actually making it to the relay and not being

shunted off to ground. For instance, you could use CT excitation tests and PT turns ratio tests and compare to baseline values to verify that the instrument transformer outputs are acceptable. However, to conclude that these acceptable transformer instrument output signals are actually making it to the relay inputs, it also would be necessary to verify the insulation of the wiring between the instrument transformer and the relay.

My plant generator and transformer relays are electromechanical and do not have metering functions, as do microprocessor-based relays. In order for me to compare the instrument transformer inputs to these relays to the secondary values of other metered instrument transformers monitoring the same primary voltage and current signals, it would be necessary to temporarily connect test equipment, like voltmeters and clamp on ammeters, to measure the input signals to the relays. This practice seems very risky, and a plant trip could result if the technician were to make an error while measuring these current and voltage signals. How can I avoid this risk? Also, what if no other instrument transformers are available which monitor the same primary voltage or current signal?

Comparing the input signals to the relays to the outputs of other independent instrument transformers monitoring the same primary current or voltage is just one method of verifying the instrument transformer inputs to the relays, but is not required by the standard. Plants can choose how to best manage their risk. If online testing is deemed too risky, offline tests, such as, but not limited to, CT excitation test and PT turns ratio tests can be compared to baseline data and be used in conjunction with CT and PT secondary wiring insulation verification tests to adequately “verify the current and voltage circuit inputs from the voltage and current sensing devices to the protective relays...” while eliminating the risk of tripping an in service generator or transformer. Similarly, this same offline test methodology can be used to verify the relay input voltage and current signals to relays when there are no other instrument transformers monitoring available for purposes of signal comparison.

15.3 Control circuitry associated with protective functions (Table 1-5)

This component of Protection Systems includes the trip coil(s) of the circuit breaker, circuit switcher or any other interrupting device. It includes the wiring from the batteries to the relays. It includes the wiring (or other signal conveyance) from every trip output to every trip coil. It includes any device needed for the correct processing of the needed trip signal to the trip coil of the interrupting device; this requirement is meant to capture inputs and outputs to and from a protective relay that are necessary for the correct operation of the protective functions. In short, every trip path must be verified; the method of verification is optional to the asset owner. An example of testing methods to accomplish this might be to verify, with a volt-meter, the existence of the proper voltage at the open contacts, the open circuited input circuit and at the trip coil(s). As every parallel trip path has similar failure modes, each trip path from relay to trip coil must be verified. Each trip coil must be tested to trip the circuit breaker (or other interrupting device) at least once. There is a requirement to operate the circuit breaker (or other interrupting device) at least once every six years as part of the complete functional test. If a suitable monitoring system is installed that verifies every parallel trip path, then the manual-intervention testing of those parallel trip paths can be eliminated; however, the actual operation of the circuit breaker must still occur at least once every six years. This six-year tripping requirement can be completed as easily as tracking the Real-time Fault-clearing operations on the circuit breaker, or tracking the trip coil(s) operation(s) during circuit breaker routine maintenance actions.

The circuit-interrupting device should not be confused with a motor-operated disconnect. The intent of this standard is to require maintenance intervals and activities on Protection Systems equipment, and not just all system isolating equipment.

It is necessary, however, to classify a device that actuates a high-speed auto-closing ground switch as an interrupting device, if this ground switch is utilized in a Protection System and forces a ground Fault to occur that then results in an expected Protection System operation to clear the forced ground Fault. The SDT believes that this is essentially a transferred-tripping device without the use of communications equipment. If this high-speed ground switch is “...designed to provide protection for the BES...” then this device needs to be treated as any other Protection System component. The control circuitry would have to be tested within 12 years, and any electromechanically operated device will have to be tested every six years. If the spring-operated ground switch can be disconnected from the solenoid triggering unit, then the solenoid triggering unit can easily be tested without the actual closing of the ground blade.

The dc control circuitry also includes each auxiliary tripping relay (94) and each lock-out relay (86) that may exist in any particular trip scheme. If the lock-out relays (86) are electromechanical type components, then they must be trip tested. The PSMT SDT considers these components to share some similarities in failure modes as electromechanical protective relays; as such, there is a six-year maximum interval between mandated maintenance tasks unless PBM is applied.

Contacts of the 86 and/or 94 that pass the trip current on to the circuit interrupting device trip coils will have to be checked as part of the 12 year requirement. Contacts of the 86 and/or 94 lock relay that operate non-BES interrupting devices are not required. Normally-open contacts that are not used to pass a trip signal and normally-closed contacts do not have to be verified. Verification of the tripping paths is the requirement.

New technology is also accommodated here; there are some tripping systems that have replaced the traditional hard-wired trip circuitry with other methods of trip-signal conveyance such as fiber-optics. It is the intent of the PSMT SDT to include this, and any other, technology that is used to convey a trip signal from a protective relay to a circuit breaker (or other interrupting device) within this category of equipment. The requirement for these systems is verification of the tripping path.

Monitoring of the control circuit integrity allows for no maintenance activity on the control circuit (excluding the requirement to operate trip coils and electromechanical lockout and/or tripping auxiliary relays). Monitoring of integrity means to monitor for continuity and/or presence of voltage on each trip path. For Ethernet or fiber-optic control systems, monitoring of integrity means to monitor communication ability between the relay and the circuit breaker.

15.3.1 Frequently Asked Questions:

Is it permissible to verify circuit breaker tripping at a different time (and interval) than when we verify the protective relays and the instrument transformers?

Yes--provided the entire Protective System is tested within the individual component's maximum allowable testing intervals.

The Protection System Maintenance Standard describes requirements for verifying the tripping of circuit breakers. What is this telling me about maintenance of circuit breakers?

Requirements in PRC-005-6 are intended to verify the integrity of tripping circuits, including the breaker trip coil, as well as the presence of auxiliary supply (usually a battery) for energizing the trip coil if a protection function operates. Beyond this, PRC-005-6 sets no requirements for verifying circuit breaker performance, or for maintenance of the circuit breaker.

How do I test each dc Control Circuit trip path, as established in Table 1-5 "Protection System Control Circuitry (Trip coils and auxiliary relays)"?

Table 1-5 specifies that each breaker trip coil and lockout relays that carry trip current to a trip coil must be operated within the specified time period. The required operations may be via targeted maintenance activities, or by documented operation of these devices for other purposes such as Fault clearing.

Are high-speed ground switch trip coils included in the dc control circuitry?

Yes--PRC-005-6 includes high-speed grounding switch trip coils within the dc control circuitry to the degree that the initiating Protection Systems are characterized as "transmission Protection Systems."

Does the control circuitry and trip coil of a non-BES breaker, tripped via a BES protection component, have to be tested per Table 1.5? (Refer to Table 3 for examples 1 and 2)

Example 1: A non-BES circuit breaker that is tripped via a Protection System to which PRC-005-6 applies might be (but is not limited to) a 12.5KV circuit breaker feeding (non-black-start) radial Loads but has a trip that originates from an under-frequency (81) relay.

- The relay must be verified.
- The voltage signal to the relay must be verified.
- All of the relevant dc supply tests still apply.
- The unmonitored trip circuit between the relay and any lock-out or auxiliary relay must be verified every 12 years.
- The unmonitored trip circuit between the lock-out (or auxiliary relay) and the non-BES breaker does not have to be proven with an electrical trip.
- In the case where there is no lock-out or auxiliary tripping relay used, the trip circuit to the non-BES breaker does not have to be proven with an electrical trip.
- The trip coil of the non-BES circuit breaker does not have to be individually proven with an electrical trip.

Example 2: A Transmission Owner may have a non-BES breaker that is tripped via a Protection System to which PRC-005-6 applies, which may be (but is not limited to) a 13.8 KV circuit breaker feeding (non-black-start) radial Loads but has a trip that originates from a BES 115KV line relay.

- The relay must be verified
- The voltage signal to the relay must be verified
- All of the relevant dc supply tests still apply

-
- The unmonitored trip circuit between the relay and any lock-out (86) or auxiliary (94) relay must be verified every 12 years
 - The unmonitored trip circuit between the lock-out (86) (or auxiliary (94)) relay and the non-BES breaker does not have to be proven with an electrical trip
 - In the case where there is no lockout (86) or auxiliary (94) tripping relay used, the trip circuit to the non-BES breaker does not have to be proven with an electrical trip.
 - The trip coil of the non-BES circuit breaker does not have to be individually proven with an electrical trip

Example 3: A Generator Owner may have a non-BES circuit breaker that is tripped via a Protection System to which PRC-005-6 applies, such as the generator field breaker and low-side breakers on station service/excitation transformers connected to the generator bus.

Trip testing of the generator field breaker and low side station service/excitation transformer breaker(s) via lockout or auxiliary tripping relays are not required since these breakers may be associated with radially fed loads and are not considered to be BES breakers. An example of an otherwise non-BES circuit breaker that is tripped via a BES protection component might be (but is not limited to) a 6.9kV station service transformer source circuit breaker but has a trip that originates from a generator differential (87) relay.

- The differential relay must be verified.
- The current signals to the relay must be verified.
- All of the relevant dc supply tests still apply.
- The unmonitored trip circuit between the relay and any lock-out or auxiliary relay must be verified every 12 years.
- The unmonitored trip circuit between the lock-out (or auxiliary relay) and the non-BES breaker does not have to be proven with an electrical trip.
- In the case where there is no lock-out or auxiliary tripping relay used, the trip circuit to the non-BES breaker does not have to be proven with an electrical trip.
- The trip coil of the non-BES circuit breaker does not have to be individually proven with an electrical trip.

However, it is very prudent to verify the tripping of such breakers for the integrity of the overall generation plant.

Do I have to verify operation of breaker "a" contacts or any other normally closed auxiliary contacts in the trip path of each breaker as part of my control circuit test?

Operation of normally-closed contacts does not have to be verified. Verification of the tripping paths is the requirement. The continuity of the normally closed contacts will be verified when the tripping path is verified.

15.4 Batteries and DC Supplies (Table 1-4)

The NERC definition of a Protection System is:

- Protective relays which respond to electrical quantities,

-
- Communications Systems necessary for correct operation of protective functions,
 - Voltage and current sensing devices providing inputs to protective relays,
 - Station dc supply associated with protective functions (including station batteries, battery chargers, and non-battery-based dc supply), and
 - Control circuitry associated with protective functions through the trip coil(s) of the circuit breakers or other interrupting devices.

The station battery is not the only component that provides dc power to a Protection System. In the new definition for Protection System, “station batteries” are replaced with “station dc supply” to make the battery charger and dc producing stored energy devices (that are not a battery) part of the Protection System that must be maintained.

The PSMT SDT recognizes that there are several technological advances in equipment and testing procedures that allow the owner to choose how to verify that a battery string is free of open circuits. The term “continuity” was introduced into the standard to allow the owner to choose how to verify continuity of a battery set by various methods, and not to limit the owner to other conventional methods of showing continuity. Continuity, as used in Table 1-4 of the standard, refers to verifying that there is a continuous current path from the positive terminal of the station battery set to the negative terminal. Without verifying continuity of a station battery, there is no way to determine that the station battery is available to supply dc power to the station. An open battery string will be an unavailable power source in the event of loss of the battery charger.

Batteries cannot be a unique population segment of a Performance-Based Maintenance Program (PBM) because there are too many variables in the electrochemical process to completely isolate all of the performance-changing criteria necessary for using PBM on battery Systems. However, nothing precludes the use of a PBM process for any other part of a dc supply besides the batteries themselves.

15.4.1 Frequently Asked Questions:

What constitutes the station dc supply, as mentioned in the definition of Protective System?

The previous definition of Protection System includes batteries, but leaves out chargers. The latest definition includes chargers, as well as dc systems that do not utilize batteries. This revision of PRC-005-6 is intended to capture these devices that were not included under the previous definition. The station direct current (dc) supply normally consists of two components: the battery charger and the station battery itself. There are also emerging technologies that provide a source of dc supply that does not include either a battery or charger.

Battery Charger - The battery charger is supplied by an available ac source. At a minimum, the battery charger must be sized to charge the battery (after discharge) and supply the constant dc load. In many cases, it may be sized also to provide sufficient dc current to handle the higher energy requirements of tripping breakers and switches when actuated by the protective relays in the Protection System.

Station Battery - Station batteries provide the dc power required for tripping and for supplying normal dc power to the station in the event of loss of the battery charger. There are several technologies of battery that require unique forms of maintenance as established in Table 1-4.

Emerging Technologies - Station dc supplies are currently being developed that use other energy storage technologies besides the station battery to prevent loss of the station dc supply when ac power is lost. Maintenance of these station dc supplies will require different kinds of tests and inspections. Table 1-4 presents maintenance activities and maximum allowable testing intervals for these new station dc supply technologies. However, because these technologies are relatively new, the maintenance activities for these station dc supplies may change over time.

What did the PSMT SDT mean by “continuity” of the dc supply?

The PSMT SDT recognizes that there are several technological advances in equipment and testing procedures that allow the owner to choose how to verify that a battery string is free of open circuits. The term “continuity” was introduced into the standard to allow the owner to choose how to verify continuity (no open circuits) of a battery set by various methods, and not to limit the owner to other conventional methods of showing continuity--lack of an open circuit. Continuity, as used in Table 1-4 of the standard, refers to verifying that there is a continuous current path from the positive terminal of the station battery set to the negative terminal (no open circuit). Without verifying continuity of a station battery, there is no way to determine that the station battery is available to supply dc power to the station. Whether it is caused from an open cell or a bad external connection, an open battery string will be an unavailable power source in the event of loss of the battery charger.

The current path through a station battery from its positive to its negative connection to the dc control circuits is composed of two types of elements. These path elements are the electrochemical path through each of its cells and all of the internal and external metallic connections and terminations of the batteries in the battery set. If there is loss of continuity (an open circuit) in any part of the electrochemical or metallic path, the battery set will not be available for service. In the event of the loss of the ac source or battery charger, the battery must be capable of supplying dc current, both for continuous dc loads and for tripping breakers and switches. Without continuity, the battery cannot perform this function.

At generating stations and large transmission stations where battery chargers are capable of handling the maximum current required by the Protection System, there are still problems that could potentially occur when the continuity through the connected battery is interrupted.

- Many battery chargers produce harmonics which can cause failure of dc power supplies in microprocessor-based protective relays and other electronic devices connected to station dc supply. In these cases, the substation battery serves as a filter for these harmonics. With the loss of continuity in the battery, the filter provided by the battery is no longer present.
- Loss of electrical continuity of the station battery will cause, in most battery chargers, regardless of the battery charger’s output current capability, a delayed response in full output current from the charger. Almost all chargers have an intentional one- to two-second delay to switch from a low substation dc load current to the maximum output of the charger. This delay would cause the opening of circuit breakers to be delayed, which could violate system performance standards.

Monitoring of the station dc supply voltage will not indicate that there is a problem with the dc current path through the battery, unless the battery charger is taken out of service. At that time,

a break in the continuity of the station battery current path will be revealed because there will be no voltage on the station dc circuitry. This particular test method, while proving battery continuity, may not be acceptable to all installations.

Although the standard prescribes what must be accomplished during the maintenance activity, it does not prescribe how the maintenance activity should be accomplished. There are several methods that can be used to verify the electrical continuity of the battery. These are not the only possible methods, simply a sampling of some methods:

- One method is to measure that there is current flowing through the battery itself by a simple clamp on milliamp-range ammeter. A battery is always either charging or discharging. Even when a battery is charged, there is still a measurable float charge current that can be detected to verify that there is continuity in the electrical path through the battery.
- A simple test for continuity is to remove the battery charger from service and verify that the battery provides voltage and current to the dc system. However, the behavior of the various dc-supplied equipment in the station should be considered before using this approach.
- Manufacturers of microprocessor-controlled battery chargers have developed methods for their equipment to periodically (or continuously) test for battery continuity. For example, one manufacturer periodically reduces the float voltage on the battery until current from the battery to the dc load can be measured to confirm continuity.
- Applying test current (as in some ohmic testing devices, or devices for locating dc grounds) will provide a current that when measured elsewhere in the string, will prove that the circuit is continuous.
- Internal ohmic measurements of the cells and units of lead-acid batteries (valve-regulated lead-acid (VRLA) & vented lead-acid (VLA)) can detect lack of continuity within the cells of a battery string; and when used in conjunction with resistance measurements of the battery's external connections, can prove continuity. Also some methods of taking internal ohmic measurements, by their very nature, can prove the continuity of a battery string without having to use the results of resistance measurements of the external connections.
- Specific gravity tests could infer continuity because without continuity there could be no charging occurring; and if there is no charging, then specific gravity will go down below acceptable levels over time.

No matter how the electrical continuity of a battery set is verified, it is a necessary maintenance activity that must be performed at the intervals prescribed by Table 1-4 to insure that the station dc supply has a path that can provide the required current to the Protection System at all times.

When should I check the station batteries to see if they have sufficient energy to perform as manufactured?

The answer to this question depends on the type of battery (valve-regulated lead-acid, vented lead-acid, or nickel-cadmium) and the maintenance activity chosen.

For example, if you have a VRLA) station battery, and you have chosen to evaluate the measured cell/unit internal ohmic values to the battery cell's baseline, you will have to perform

verification at a maximum maintenance interval of no greater than every six months. While this interval might seem to be quite short, keep in mind that the six-month interval is important for VRLA batteries; this interval provides an accumulation of data that better shows when a VRLA battery is incapable of performing as manufactured.

If, for a VRLA station battery, you choose to conduct a performance capacity test on the entire station battery as the maintenance activity, then you will have to perform verification at a maximum maintenance interval of no greater than every three calendar years.

How is a baseline established for cell/unit internal ohmic measurements?

Establishment of cell/unit internal ohmic baseline measurements should be completed when lead-acid batteries are newly installed. To ensure that the baseline ohmic cell/unit values are most indicative of the station battery's ability to perform as manufactured, they should be made at some point in time after the installation to allow the cell chemistry to stabilize after the initial freshening charge. An accepted industry practice for establishing baseline values is after six-months of installation, with the battery fully charged and in service. However, it is recommended that each owner, when establishing a baseline, should consult the battery manufacturer for specific instructions on establishing an ohmic baseline for their product, if available.

When internal ohmic measurements are taken, the same make/model test equipment should be used to establish the baseline and used for the future trending of the cells internal ohmic measurements because of variances in test equipment and the type of ohmic measurement used by different manufacturer's equipment. Keep in mind that one manufacturer's "conductance" test equipment does not produce similar results as another manufacturer's "conductance" test equipment, even though both manufacturers have produced "ohmic" test equipment. Therefore, for meaningful results to an established baseline, the same make/model of instrument should be used.

For all new installations of VRLA batteries and VLA batteries, where trending of the cells internal ohmic measurements to a baseline are to be used to determine the ability of the station battery to perform as manufactured, the establishment of the baseline, as described above, should be followed at the time of installation to insure the most accurate trending of the cell/unit. However, often for older VRLA batteries, the owners of the station batteries have not established a baseline at installation. Also for owners of VLA batteries who want to establish a maintenance activity which requires trending of measured ohmic values to a baseline, there was typically no baseline established at installation of the station battery to trend to.

To resolve the problem of the unavailability of baseline internal ohmic measurements for the individual cell/unit of a station battery, many manufacturers of internal ohmic measurement devices have established libraries of baseline values for VRLA and VLA batteries using their testing device. Also, several of the battery manufacturers have libraries of baselines for their products that can be used to trend to. However, it is important that when using battery manufacturer-supplied data that it is verified that the baseline readings to be used were taken with the same ohmic testing device that will be used for future measurements (for example "conductance readings" from one manufacturer's test equipment do not correlate to "impedance readings" from a different manufacturer's test equipment). Although many manufacturers may have provided baseline values, which will allow trending of the internal ohmic measurements over the remaining life of a station battery, these baselines are not the actual cell/unit measurements for

the battery being trended. It is important to have a baseline tailored to the station battery to more accurately use the tool of ohmic measurement trending. That more customized baseline can only be created by following the establishment of a baseline for each cell/unit at the time of installation of the station battery.

Why determine the State of Charge?

Even though there is no present requirement to check the state of charge of a battery, it can be a very useful tool in determining the overall condition of a battery system. The following discussions are offered as a general reference.

When a battery is fully charged, the battery is available to deliver its existing capacity. As a battery is discharged, its ability to deliver its maximum available capacity is diminished. It is necessary to determine if the state of charge has dropped to an unacceptable level.

What is State of Charge and how can it be determined in a station battery?

The state of charge of a battery refers to the ratio of residual capacity at a given instant to the maximum capacity available from the battery. When a battery is fully charged, the battery is available to deliver its existing capacity. As a battery is discharged, its ability to deliver its maximum available capacity is diminished. Knowing the amount of energy left in a battery compared with the energy it had when it was fully charged gives the user an indication of how much longer a battery will continue to perform before it needs recharging.

For VLA batteries which use accessible liquid electrolyte, a hydrometer can be used to test the specific gravity of each cell as a measure of its state of charge. The hydrometer depends on measuring changes in the weight of the active chemicals. As the battery discharges, the active electrolyte, sulfuric acid, is consumed and the concentration of the sulfuric acid in water is reduced. This, in turn, reduces the specific gravity of the solution in direct proportion to the state of charge. The actual specific gravity of the electrolyte can, therefore, be used as an indication of the state of charge of the battery. Hydrometer readings may not tell the whole story, as it takes a while for the acid to get mixed up in the cells of a VLA battery. If measured right after charging, you might see high specific gravity readings at the top of the cell, even though it is much less at the bottom. Conversely, if taken shortly after adding water to the cell, the specific gravity readings near the top of the cell will be lower than those at the bottom.

Nickel-cadmium batteries, where the specific gravity of the electrolyte does not change during battery charge and discharge, and VRLA batteries, where the electrolyte is not accessible, cannot have their state of charge determined by specific gravity readings. For these two types of batteries, and for VLA batteries also, where another method besides taking hydrometer readings is desired, the state of charge may be determined by taking voltage and current readings at the battery terminals. The methods employed to obtain accurate readings vary for the different battery types. Manufacturers' information and IEEE guidelines can be consulted for specifics; (see IEEE 1106 Annex B for Nickel Cadmium batteries, IEEE 1188 Annex A for VRLA batteries and IEEE 450 for VLA batteries.

Why determine the Connection Resistance?

High connection resistance can cause abnormal voltage drop or excessive heating during discharge of a station battery. During periods of a high rate of discharge of the station battery, a very high resistance can cause severe damage. The maintenance requirement to verify battery terminal connection resistance in Table 1-4 is established to verify that the integrity of all battery electrical connections is acceptable. This verification includes cell-to-cell (intercell) and external

circuit terminations. Your method of checking for acceptable values of intercell and terminal connection resistance could be by individual readings, or a combination of the two. There are test methods presently that can read post termination resistances and resistance values between external posts. There are also test methods presently available that take a combination reading of the post termination connection resistance plus the intercell resistance value plus the post termination connection resistance value. Either of the two methods, or any other method, that can show if the adequacy of connections at the battery posts is acceptable.

Adequacy of the electrical terminations can be determined by comparing resistance measurements for all connections taken at the time of station battery's installation to the same resistance measurements taken at the maintenance interval chosen, not to exceed the maximum maintenance interval of Table 1-4. Trending of the interval measurements to the baseline measurements will identify any degradation in the battery connections. When the connection resistance values exceed the acceptance criteria for the connection, the connection is typically disassembled, cleaned, reassembled and measurements taken to verify that the measurements are adequate when compared to the baseline readings.

What conditions should be inspected for visible battery cells?

The maintenance requirement to inspect the cell condition of all station battery cells where the cells are visible is a maintenance requirement of Table 1-4. Station batteries are different from any other component in the Protection Station because they are a perishable product due to the electrochemical process which is used to produce dc electrical current and voltage. This inspection is a detailed visual inspection of the cells for abnormalities that occur in the aging process of the cell. In VLA battery visual inspections, some of the things that the inspector is typically looking for on the plates are signs of sulfation of the plates, abnormal colors (which are an indicator of sulfation or possible copper contamination) and abnormal conditions such as cracked grids. The visual inspection could look for symptoms of hydration that would indicate that the battery has been left in a completely discharged state for a prolonged period. Besides looking at the plates for signs of aging, all internal connections, such as the bus bar connection to each plate, and the connections to all posts of the battery need to be visually inspected for abnormalities. In a complete visual inspection for the condition of the cell the cell plates, separators and sediment space of each cell must be looked at for signs of deterioration. An inspection of the station battery's cell condition also includes looking at all terminal posts and cell-to-cell electric connections to ensure they are corrosion free. The case of the battery containing the cell, or cells, must be inspected for cracks and electrolyte leaks through cracks and the post seals.

This maintenance activity cannot be extended beyond the maximum maintenance interval of Table 1-4 by a Performance-Based Maintenance Program (PBM) because of the electrochemical aging process of the station battery, nor can there be any monitoring associated with it because there must be a visual inspection involved in the activity. A remote visual inspection could possibly be done, but its interval must be no greater than the maximum maintenance interval of Table 1-4.

Why is it necessary to verify the battery string can perform as manufactured? I only care that the battery can trip the breaker, which means that the battery can perform as designed. I oversize my batteries so that even if the battery cannot perform as manufactured, it can still trip my breakers.

The fundamental answer to this question revolves around the concept of battery performance “as designed” vs. battery performance “as manufactured.” The purpose of the various sections of Table 1-4 of this standard is to establish requirements for the Protection System owner to maintain the batteries, to ensure they will operate the equipment when there is an incident that requires dc power, and ensure the batteries will continue to provide adequate service until at least the next maintenance interval. To meet these goals, the correct battery has to be properly selected to meet the design parameters, and the battery has to deliver the power it was manufactured to provide.

When testing batteries, it may be difficult to determine the original design (i.e., load profile) of the dc system. This standard is not intended as a design document, and requirements relating to design are, therefore, not included.

Where the dc load profile is known, the best way to determine if the system will operate as designed is to conduct a service test on the battery. However, a service test alone might not fully determine if the battery is healthy. A battery with 50% capacity may be able to pass a service test, but the battery would be in a serious state of deterioration and could fail at some point in the near future.

To ensure that the battery will meet the required load profile and continue to meet the load profile until the next maintenance interval, the installed battery must be sized correctly (i.e., a correct design), and it must be in a good state of health. Since the design of the dc system is not within the scope of the standard, the only consistent and reliable method to ensure that the battery is in a good state of health is to confirm that it can perform as manufactured. If the battery can perform as manufactured and it has been designed properly, the system should operate properly until the next maintenance interval.

How do I verify the battery string can perform as manufactured?

Optimally, actual battery performance should be verified against the manufacturer’s rating curves. The best practice for evaluating battery performance is via a performance test. However, due to both logistical and system reliability concerns, some Protection System owners prefer other methods to determine if a battery can perform as manufactured. There are several battery parameters that can be evaluated to determine if a battery can perform as manufactured. Ohmic measurements and float current are two examples of parameters that have been reported to assist in determining if a battery string can perform as manufactured.

The evaluation of battery parameters in determining battery health is a complex issue, and is not an exact science. This standard gives the user an opportunity to utilize other measured parameters to determine if the battery can perform as manufactured. It is the responsibility of the Protection System owner, however, to maintain a documented process that demonstrates the chosen parameter(s) and associated methodology used to determine if the battery string can perform as manufactured.

Whatever parameters are used to evaluate the battery (ohmic measurements, float current, float voltages, temperature, specific gravity, performance test, or combination thereof), the goal is to determine the value of the measurement (or the percentage change) at which the battery fails

to perform as manufactured, or the point where the battery is deteriorating so rapidly that it will not perform as manufactured before the next maintenance interval.

This necessitates the need for establishing and documenting a baseline. A baseline may be required of every individual cell, a particular battery installation, or a specific make, model, or size of a cell. Given a consistent cell manufacturing process, it may be possible to establish a baseline number for the cell (make/model/type) and, therefore, a subsequent baseline for every installation would not be necessary. However, future installations of the same battery types should be spot-checked to ensure that your baseline remains applicable.

Consistent testing methods by trained personnel are essential. Moreover, it is essential that these technicians utilize the same make/model of ohmic test equipment each time readings are taken in order to establish a meaningful and accurate trend line against the established baseline. The type of probe and its location (post, connector, etc.) for the reading need to be the same for each subsequent test. The room temperature should be recorded with the readings for each test as well. Care should be taken to consider any factors that might lead a trending program to become invalid.

Float current along with other measurable parameters can be used in lieu of or in concert with ohmic measurement testing to measure the ability of a battery to perform as manufactured. The key to using any of these measurement parameters is to establish a baseline and the point where the reading indicates that the battery will not perform as manufactured.

The establishment of a baseline may be different for various types of cells and for different types of installations. In some cases, it may be possible to obtain a baseline number from the battery manufacturer, although it is much more likely that the baseline will have to be established after the installation is complete. To some degree, the battery may still be “forming” after installation; consequently, determining a stable baseline may not be possible until several months after the battery has been in service.

The most important part of this process is to determine the point where the ohmic reading (or other measured parameter(s)) indicates that the battery cannot perform as manufactured. That point could be an absolute number, an absolute change, or a percentage change of an established baseline.

Since there are no universally-accepted repositories of this information, the Protection System owner will have to determine the value/percentage where the battery cannot perform as manufactured (heretofore referred to as a failed cell). This is the most difficult and important part of the entire process.

To determine the point where the battery fails to perform as manufactured, it is helpful to have a history of a battery type, if the data includes the parameter(s) used to evaluate the battery's ability to perform as manufactured against the actual demonstrated performance/capacity of a battery/cell.

For example, when an ohmic reading has been recorded that the user suspects is indicating a failed cell, a performance test of that cell (or string) should be conducted in order to prove/quantify that the cell has failed. Through this process, the user needs to determine the ohmic value at which the performance of the cell has dropped below 80% of the manufactured, rated performance. It is likely that there may be a variation in ohmic readings that indicates a

failed cell (possibly significant). It is prudent to use the most conservative values to determine the point at which the cell should be marked for replacement. Periodically, the user should demonstrate that an “adequate” ohmic reading equates to an adequate battery performance (>80% of capacity).

Similarly, acceptance criteria for "good" and "failed" cells should be established for other parameters such as float current, specific gravity, etc., if used to determine the ability of a battery to function as designed.

What happens if I change the make/model of ohmic test equipment after the battery has been installed for a period of time?

If a user decides to switch testers, either voluntarily or because the equipment is not supported/sold any longer, the user may have to establish a new base line and new parameters that indicate when the battery no longer performs as manufactured. The user always has a choice to perform a capacity test in lieu of establishing new parameters.

What are some of the differences between lead-acid and nickel-cadmium batteries?

There is a marked difference in the aging process of lead acid and nickel-cadmium station batteries. The difference in the aging process of these two types of batteries is chiefly due to the electrochemical process of the battery type. Aging and eventual failure of lead acid batteries is due to expansion and corrosion of the positive grid structure, loss of positive plate active material, and loss of capacity caused by physical changes in the active material of the positive plates. In contrast, the primary failure of nickel-cadmium batteries is due to the gradual linear aging of the active materials in the plates. The electrolyte of a nickel-cadmium battery only facilitates the chemical reaction (it functions only to transfer ions between the positive and negative plates), but is not chemically altered during the process like the electrolyte of a lead acid battery. A lead acid battery experiences continued corrosion of the positive plate and grid structure throughout its operational life while a nickel-cadmium battery does not.

Changes to the properties of a lead acid battery when periodically measured and trended to a baseline, can indicate aging of the grid structure, positive plate deterioration, or changes in the active materials in the plate.

Because of the clear differences in the aging process of lead acid and nickel-cadmium batteries, there are no significantly measurable properties of the nickel-cadmium battery that can be measured at a periodic interval and trended to determine aging. For this reason, Table 1-4(c) (Protection System Station dc supply Using nickel-cadmium [NiCad] Batteries) only specifies one minimum maintenance activity and associated maximum maintenance interval necessary to verify that the station battery can perform as manufactured by evaluating cell/unit measurements indicative of battery performance against the station battery baseline. This maintenance activity is to conduct a performance or modified performance capacity test of the entire battery bank.

Why in Table 1-4 of PRC-005-6 is there a maintenance activity to inspect the structural integrity of the battery rack?

The purpose of this inspection is to verify that the battery rack is correctly installed and has no deterioration that could weaken its structural integrity.

Because the battery rack is specifically manufactured for the battery that is mounted on it, weakening of its structural members by rust or corrosion can physically jeopardize the battery.

What is required to comply with the “Unintentional dc Grounds” requirement?

In most cases, the first ground that appears on a battery is not a problem. It is the unintentional ground that appears on the opposite pole that becomes problematic. Even then many systems are designed to operate favorably under some unintentional dc ground situations. It is up to the owner of the Protection System to determine if corrective actions are needed on detected unintentional dc grounds. The standard merely requires that a check be made for the existence of unintentional dc grounds. Obviously, a “check-off” of some sort will have to be devised by the inspecting entity to document that a check is routinely done for unintentional dc grounds because of the possible consequences to the Protection System.

Where the standard refers to “all cells,” is it sufficient to have a documentation method that refers to “all cells,” or do we need to have separate documentation for every cell? For example, do I need 60 individual documented check-offs for good electrolyte level, or would a single check-off per bank be sufficient?

A single check-off per battery bank is sufficient for documentation, as long as the single check-off attests to checking all cells/units.

Does this standard refer to Station batteries or all batteries; for example, Communications Site Batteries?

This standard refers to Station Batteries. The drafting team does not believe that the scope of this standard refers to communications sites. The batteries covered under PRC-005-6 are the batteries that supply the trip current to the trip coils of the interrupting devices that are a part of the Protection System. The SDT believes that a loss of power to the communications systems at a remote site would cause the communications systems associated with protective relays to alarm at the substation. At this point, the corrective actions can be initiated.

What are cell/unit internal ohmic measurements?

With the introduction of VRLA batteries to station dc supplies in the 1980’s several of the standard maintenance tools that are used on VLA batteries were unable to be used on this new type of lead-acid battery to determine its state of health. The only tools that were available to give indication of the health of these new VRLA batteries were voltage readings of the total battery voltage, the voltage of the individual cells and periodic discharge tests.

In the search for a tool for determining the health of a VRLA battery several manufacturers studied the electrical model of a lead acid battery’s current path through its cell. The overall battery current path consists of resistance and inductive and capacitive reactance. The inductive reactance in the current path through the battery is so minuscule when compared to the huge capacitive reactance of the cells that it is often ignored in most circuit models of the battery cell. Taking the basic model of a battery cell manufacturers of battery test equipment have developed and marketed testing devices to take measurements of the current path to detect degradation in the internal path through the cell.

In the battery industry, these various types of measurements are referred to as ohmic measurements. Terms used by the industry to describe ohmic measurements are ac conductance, ac impedance, and dc resistance. They are defined by the test equipment providers and IEEE and refer to the method of taking ohmic measurements of a lead acid battery. For example, in one manufacturer’s ac conductance equipment measurements are taken by applying a voltage of a known frequency and amplitude across a cell or battery unit and observing the ac

current flow it produces in response to the voltage. A manufacturer of an ac impedance meter measures ac current of a known frequency and amplitude that is passed through the whole battery string and determines the impedances of each cell or unit by measuring the resultant ac voltage drop across them. On the other hand, dc resistance of a cell is measured by a third manufacturer's equipment by applying a dc load across the cell or unit and measuring the step change in both the voltage and current to calculate the internal dc resistance of the cell or unit.

It is important to note that because of the rapid development of the market for ohmic measurement devices, there were no standards developed or used to mandate the test signals used in making ohmic measurements. Manufacturers using proprietary methods and applying different frequencies and magnitudes for their signals have developed a diversity of measurement devices. This diversity in test signals coupled with the three different types of ohmic measurements techniques (impedance conductance and resistance) make it impossible to always get the same ohmic measurement for a cell with different ohmic measurement devices. However, IEEE has recognized the great value for choosing one device for ohmic measurement, no matter who makes it or the method to calculate the ohmic measurement. The only caution given by IEEE and the battery manufacturers is that when trending the cells of a lead acid station battery consistent ohmic measurement devices should be used to establish the baseline measurement and to trend the battery set for its entire life.

For VRLA batteries both IEEE Standard 1188 (Maintenance, Testing and Replacement of VRLA Batteries) and IEEE Standard 1187 (Installation Design and Installation of VRLA Batteries) recognize the importance of the maintenance activity of establishing a baseline for "cell/unit internal ohmic measurements (impedance, conductance and resistance)" and trending them at frequent intervals over the life of the battery. There are extensive discussions about the need for taking these measurements in these standards. IEEE Standard 1188 requires taking internal ohmic values as described in Annex C4 during regular inspections of the station battery. For VRLA batteries IEEE Standard 1188 in talking about the necessity of establishing a baseline and trending it over time says, "...depending on the degree of change a performance test, cell replacement or other corrective action may be necessary..." (IEEE std 1188-2005, C.4 page 18).

For VLA batteries IEEE Standard 484 (Installation of VLA batteries) gives several guidelines about establishing baseline measurements on newly installed lead acid stationary batteries. The standard also discusses the need to look for significant changes in the ohmic measurements, the caution that measurement data will differ with each type of model of instrument used, and lists a number of factors that affect ohmic measurements.

At the beginning of the 21st century, EPRI conducted a series of extensive studies to determine the relationship of internal ohmic measurements to the capacity of a lead acid battery cell. The studies indicated that internal ohmic measurements were in fact a good indicator of a lead acid battery cell's capacity, but because users often were only interested in the total station battery capacity and the technology does not precisely predict overall battery capacity, if a user only needs "an accurate measure of the overall battery capacity," they should "perform a battery capacity test."

Prior to the EPRI studies some large and small companies which owned and maintained station dc supplies in NERC Protection Systems developed maintenance programs where trending of ohmic measurements of cells/units of the station's battery became the maintenance activity for determining if the station battery could perform as manufactured. By evaluation of the trending

of the ohmic measurements over time, the owner could track the performance of the individual components of the station battery and determine if a total station battery or components of it required capacity testing, removal, replacement or in many instances replacement of the entire station battery. By taking this condition based approach these owners have eliminated having to perform capacity testing at prescribed intervals to determine if a battery needs to be replaced and are still able to effectively determine if a station battery can perform as manufactured.

My VRLA batteries have multiple-cells within an individual battery jar (or unit); how am I expected to comply with the cell-to-cell ohmic measurement requirements on these units that I cannot get to?

Measurement of cell/unit (not all batteries allow access to “individual cells” some “units” or jars may have multiple cells within a jar) internal ohmic values of all types of lead acid batteries where the cells of the battery are not visible is a station dc supply maintenance activity in Table 1-4. In cases where individual cells in a multi-cell unit are inaccessible, an ohmic measurement of the entire unit may be made.

I have a concern about my batteries being used to support additional auxiliary loads beyond my protection control systems in a generation station. Is ohmic measurement testing sufficient for my needs?

While this standard is focused on addressing requirements for Protection Systems, if batteries are used to service other load requirements beyond that of Protection Systems (e.g. pumps, valves, inverter loads), the functional entity may consider additional testing to confirm that the capacity of the battery is sufficient to support all loads.

Why verify voltage?

There are two required maintenance activities associated with verification of dc voltages in Table 1-4. These two required activities are to verify station dc supply voltage and float voltage of the battery charger, and have different maximum maintenance intervals. Both of these voltage verification requirements relate directly to the battery charger maintenance.

The verification of the dc supply voltage is simply an observation of battery voltage to prove that the charger has not been lost or is not malfunctioning; a reading taken from the battery charger panel meter or even SCADA values of the dc voltage could be some of the ways that one could satisfy the requirements. Low battery voltage below float voltage indicates that the battery may be on discharge and, if not corrected, the station battery could discharge down to some extremely low value that will not operate the Protection System. High voltage, close to or above the maximum allowable dc voltage for equipment connected to the station dc supply indicates the battery charger may be malfunctioning by producing high dc voltage levels on the Protection System. If corrective actions are not taken to bring the high voltage down, the dc power supplies and other electronic devices connected to the station dc supply may be damaged. The maintenance activity of verifying the float voltage of the battery charger is not to prove that a charger is lost or producing high voltages on the station dc supply, but rather to prove that the charger is properly floating the battery within the proper voltage limits. As above, there are many ways that this requirement can be met.

Why check for the electrolyte level?

In VLA and nickel-cadmium (NiCad) batteries the visible electrolyte level must be checked as one of the required maintenance activities that must be performed at an interval that is equal to or less than the maximum maintenance interval of Table 1-4. Because the electrolyte level in VRLA batteries cannot be observed, there is no maintenance activity listed in Table 1-4 of the standard for checking the electrolyte level. Low electrolyte level of any cell of a VLA or NiCad station battery is a condition requiring correction. Typically, the electrolyte level should be returned to an acceptable level for both types of batteries (VLA and NiCad) by adding distilled or other approved-quality water to the cell.

Often people confuse the interval for watering all cells required due to evaporation of the electrolyte in the station battery cells with the maximum maintenance interval required to check the electrolyte level. In many of the modern station batteries, the jar containing the electrolyte is so large with the band between the high and low electrolyte level so wide that normal evaporation which would require periodic watering of all cells takes several years to occur. However, because loss of electrolyte due to cracks in the jar, overcharging of the station battery, or other unforeseen events can cause rapid loss of electrolyte; the shorter maximum maintenance intervals for checking the electrolyte level are required. A low level of electrolyte in a VLA battery cell which exposes the tops of the plates can cause the exposed portion of the plates to accelerated sulfation resulting in loss of cell capacity. Also, in a VLA battery where the electrolyte level goes below the end of the cell withdrawal tube or filling funnel, gasses can exit the cell by the tube instead of the flame arrester and present an explosion hazard.

What are the parameters that can be evaluated in Tables 1-4(a) and 1-4(b)?

The most common parameter that is periodically trended and evaluated by industry today to verify that the station battery can perform as manufactured is internal ohmic cell/unit measurements.

In the mid-1990s, several large and small utilities began developing maintenance and testing programs for Protection System station batteries using a condition based maintenance approach of trending internal ohmic measurements to each station battery cell's baseline value. Battery owners use the data collected from this maintenance activity to determine (1) when a station battery requires a capacity test (instead of performing a capacity test on a predetermined, prescribed interval), (2) when an individual cell or battery unit should be replaced, or (3) based on the analysis of the trended data, if the station battery should be replaced without performing a capacity test.

Other examples of measurable parameters that can be periodically trended and evaluated for lead acid batteries are cell voltage, float current, connection resistance. However, periodically trending and evaluating cell/unit Ohmic measurements are the most common battery/cell parameters that are evaluated by industry to verify a lead acid battery string can perform as manufactured.

Why does it appear that there are two maintenance activities in Table 1-4(b) (for VRLA batteries) that appear to be the same activity and have the same maximum maintenance interval?

There are two different and distinct reasons for doing almost the same maintenance activity at the same interval for VRLA batteries. The first similar activity for VRLA batteries (Table 1-4(b))

that has the same maximum maintenance interval is to “measure battery cell/unit internal ohmic values.” Part of the reason for this activity is because the visual inspection of the cell condition is unavailable for VRLA batteries. Besides the requirement to measure the internal ohmic measurements of VRLA batteries to determine the internal health of the cell, the maximum maintenance interval for this activity is significantly shorter than the interval for VLA due to some unique failure modes for VRLA batteries. Some of the potential problems that VRLA batteries are susceptible to that do not affect VLA batteries are thermal runaway, cell dry-out, and cell reversal when one cell has a very low capacity.

The other similar activity listed in Table 1-4(b) is “...verify that the station battery can perform as manufactured by evaluating the measured cell/unit measurements indicative of battery performance (e.g. internal ohmic values) against the station battery baseline.” This activity allows an owner the option to choose between this activity with its much shorter maximum maintenance interval or the longer maximum maintenance interval for the maintenance activity to “Verify that the station battery can perform as manufactured by conducting a performance or modified performance capacity test of the entire battery bank.”

For VRLA batteries, there are two drivers for internal ohmic readings. The first driver is for a means to trend battery life. Trending against the baseline of VRLA cells in a battery string is essential to determine the approximate state of health of the battery. Ohmic measurement testing may be used as the mechanism for measuring the battery cells. If all the cells in the string exhibit a consistent trend line and that trend line has not risen above a specific deviation (e.g. 30%) over baseline for impedance tests or below baseline for conductance tests, then a judgment can be made that the battery is still in a reasonably good state of health and able to ‘perform as manufactured.’ It is essential that the specific deviation mentioned above is based on data (test or otherwise) that correlates the ohmic readings for a specific battery/tester combination to the health of the battery. This is the intent of the “perform as manufactured six-month test” at Row 4 on Table 1-4b.

The second big driver is VRLA batteries tendency for thermal runaway. This is the intent of the “thermal runaway test” at Row 2 on Table 1-4b. In order to detect a cell in thermal runaway, you need not necessarily have a formal trending program. When a single cell/unit changes significantly or significantly varies from the other cells (e.g. a doubling of resistance/impedance or a 50% decrease in conductance), there is a high probability that the cell/unit/string needs to be replaced as soon as possible. In other words, if the battery is 10 years old and all the cells have approached a significant change in ohmic values over baseline, then you have a battery which is approaching end of life. You need to get ready to buy a new battery, but you do not have to worry about an impending catastrophic failure. On the other hand, if the battery is five years old and you have one cell that has a markedly different ohmic reading than all the other cells, then you need to be worried that this cell is susceptible to thermal runaway. If the float (charging) current has risen significantly and the ohmic measurement has increased/decreased as described above then concern of catastrophic failure should trigger attention for corrective action.

If an entity elects to use a capacity test rather than a cell ohmic value trending program, this does not eliminate the need to be concerned about thermal runaway--the entity still needs to do the six-month readings and look for cells which are outliers in the string but they need not trend

results against the factory/as new baseline. Some entities will not mind the extra administrative burden of having the ongoing trending program against baseline--others would rather just do the capacity test and not have to trend the data against baseline. Nonetheless, all entities must look for ohmic outliers on a six-month basis.

It is possible to accomplish both tasks listed (trend testing for capability and testing for thermal runaway candidates) with the very same ohmic test. It becomes an analysis exercise of watching the trend from baselines and watching for the oblique cell measurement.

In table 1-4(f) (Exclusions for Protection System Station dc Supply Monitoring Devices and Systems), must all component attributes listed in the table be met before an exclusion can be granted for a maintenance activity?

Table 1-4(f) was created by the drafting team to allow Protection System dc supply owners to obtain exclusions from periodic maintenance activities by using monitoring devices. The basis of the exclusions granted in the table is that the monitoring devices must incorporate the monitoring capability of microprocessor based components which perform continuous self-monitoring. For failure of the microprocessor device used in dc supply monitoring, the self-checking routine in the microprocessor must generate an alarm which will be reported within 24 hours of device failure to a location where corrective action can be initiated.

Table 1-4(f) lists 8 component attributes along with a specific periodic maintenance activity associated with each of the 8 attributes listed. If an owner of a station dc supply wants to be excluded from periodically performing one of the 8 maintenance activities listed in table 1-4(f), the owner must have evidence that the monitoring and alarming component attributes associated with the excluded maintenance activity are met by the self-checking microprocessor based device with the specific component attribute listed in the table 1-4(f).

For example if an owner of a VLA station battery does not want to “verify station dc supply voltage” every “4 calendar months” (see table 1-4(a)), the owner can install a monitoring and alarming device “with high and low voltage monitoring and alarming of the battery charger voltage to detect charger overvoltage and charger failure” and “no periodic verification of station dc supply voltage is required” (see table 1-4(f) first row). However, if for the same Protection System discussed above, the owner does not install “electrolyte level monitoring and alarming in every cell” and “unintentional dc ground monitoring and alarming” (see second and third rows of table 1-4(f)), the owner will have to “inspect electrolyte level and for unintentional grounds” every “4 calendar months” (see table 1-4(a)).

15.5 Associated communications equipment (Table 1-2)

The equipment used for tripping in a communications-assisted trip scheme is a vital piece of the trip circuit. Remote action causing a local trip can be thought of as another parallel trip path to the trip coil that must be tested. Besides the trip output and wiring to the trip coil(s), there is also a communications medium that must be maintained. Newer technologies now exist that achieve communications-assisted tripping without the conventional wiring practices of older technology. For example, older technologies may have included Frequency Shift Key methods. This technology requires that guard and trip levels be maintained. The actual tripping path(s) to the trip coil(s) may be tested as a parallel trip path within the dc control circuitry tests. Emerging technologies transfer digital information over a variety of carrier mediums that are then interpreted locally as trip signals. The requirements apply to the communicated signal needed

for the proper operation of the protective relay trip logic or scheme. Therefore, this standard is applied to equipment used to convey both trip signals (permissive or direct) and block signals.

It was the intent of this standard to require that a test be performed on any communications-assisted trip scheme, regardless of the vintage of technology. The essential element is that the tripping (or blocking) occurs locally when the remote action has been asserted; or that the tripping (or blocking) occurs remotely when the local action is asserted. Note that the required testing can still be done within the concept of testing by overlapping segments. Associated communications equipment can be (but is not limited to) testing at other times and different frequencies as the protective relays, the individual trip paths and the affected circuit interrupting devices.

Some newer installations utilize digital signals over fiber-optics from the protective relays in the control house to the circuit interrupting device in the yard. This method of tripping the circuit breaker, even though it might be considered communications, must be maintained per the dc control circuitry maintenance requirements.

15.5.1 Frequently Asked Questions:

What are some examples of mechanisms to check communications equipment functioning?

For unmonitored Protection Systems, various types of communications systems will have different facilities for on-site integrity checking to be performed at least every four months during a substation visit. Some examples are, but not limited to:

- On-off power-line carrier systems can be checked by performing a manual carrier keying test between the line terminals, or carrier check-back test from one terminal.
- Systems which use frequency-shift communications with a continuous guard signal (over a telephone circuit, analog microwave system, etc.) can be checked by observing for a loss-of-guard indication or alarm. For frequency-shift power-line carrier systems, the guard signal level meter can also be checked.
- Hard-wired pilot wire line Protection Systems typically have pilot-wire monitoring relays that give an alarm indication for a pilot wire ground or open pilot wire circuit loop.
- Digital communications systems typically have a data reception indicator or data error indicator (based on loss of signal, bit error rate, or frame error checking).

For monitored Protection Systems, various types of communications systems will have different facilities for monitoring the presence of the communications channel, and activating alarms that can be monitored remotely. Some examples are, but not limited to:

- On-off power-line carrier systems can be shown to be operational by automated periodic power-line carrier check-back tests with remote alarming of failures.
- Systems which use a frequency-shift communications with a continuous guard signal (over a telephone circuit, analog microwave system, etc.) can be remotely monitored with a loss-of-guard alarm or low signal level alarm.

-
- Hard-wired pilot wire line Protection Systems can be monitored by remote alarming of pilot-wire monitoring relays.
 - Digital communications systems can activate remotely monitored alarms for data reception loss or data error indications.
 - Systems can be queried for the data error rates.

For the highest degree of monitoring of Protection Systems, the communications system must monitor all aspects of the performance and quality of the channel that show it meets the design performance criteria, including monitoring of the channel interface to protective relays.

- In many communications systems signal quality measurements, including signal-to-noise ratio, received signal level, reflected transmitter power or standing wave ratio, propagation delay, and data error rates are compared to alarm limits. These alarms are connected for remote monitoring.
- Alarms for inadequate performance are remotely monitored at all times, and the alarm communications system to the remote monitoring site must itself be continuously monitored to assure that the actual alarm status at the communications equipment location is continuously being reflected at the remote monitoring site.

What is needed for the four-month inspection of communications-assisted trip scheme equipment?

The four-month inspection applies to unmonitored equipment. An example of compliance with this requirement might be, but is not limited to:

With each site visit, check that the equipment is free from alarms; check any metered signal levels, and that power is still applied. While this might be explicit for a particular type of equipment (i.e., FSK equipment), the concept should be that the entity verify that the communications equipment that is used in a Protection System is operable through a cursory inspection and site visit. This site visit can be eliminated on this particular example if the FSK equipment had a monitored alarm on Loss of Guard. Blocking carrier systems with auto checkbacks will present an alarm when the channel fails allowing a visual indication. With no auto checkback, the channel integrity will need to be verified by a manual checkback or a two ended signal check. This check could also be eliminated by bring the auto checkback failure alarm to the monitored central location.

Does a fiber optic I/O scheme used for breaker tripping or control within a station, for example - transmitting a trip signal or control logic between the control house and the breaker control cabinet, constitute a communications system?

This equipment is presently classified as being part of the Protection System control circuitry and tested per the portions of Table 1 applicable to “Protection System Control Circuitry”, rather than those portions of the table applicable to communications equipment.

What is meant by “Channel” and “Communications Systems” in Table 1-2?

The transmission of logic or data from a relay in one station to a relay in another station for use in a pilot relay scheme will require a communications system of some sort. Typical relay communications systems use fiber optics, leased audio channels, power line carrier, and microwave. The overall communications system includes the channel and the associated communications equipment.

This standard refers to the “channel” as the medium between the transmitters and receivers in the relay panels such as a leased audio or digital communications circuit, power line and power line carrier auxiliary equipment, and fiber. The dividing line between the channel and the associated communications equipment is different for each type of media.

Examples of the Channel:

- Power Line Carrier (PLC) - The PLC channel starts and ends at the PLC transmitter and receiver output unless there is an internal hybrid. The channel includes the external hybrids, tuners, wave traps and the power line itself.
- Microwave –The channel includes the microwave multiplexers, radios, antennae and associated auxiliary equipment. The audio tone and digital transmitters and receivers in the relay panel are the associated communications equipment.
- Digital/Audio Circuit – The channel includes the equipment within and between the substations. The associated communications equipment includes the relay panel transmitters and receivers and the interface equipment in the relays.
- Fiber Optic – The channel starts at the fiber optic connectors on the fiber distribution panel at the local station and goes to the fiber optic distribution panel at the remote substation. The jumpers that connect the relaying equipment to the fiber distribution panel and any optical-electrical signal format converters are the associated communications equipment.

Figure 1-2, A-1 and A-2 at the end of this document show good examples of the communications channel and the associated communications equipment.

In Table 1-2, the Maintenance Activities section of the Protection System Communications Equipment and Channels refers to the quality of the channel meeting “performance criteria.” What is meant by performance criteria?

Protection System communications channels must have a means of determining if the channel and communications equipment is operating normally. If the channel is not operating normally, an alarm will be indicated. For unmonitored systems, this alarm will probably be on the panel. For monitored systems, the alarm will be transmitted to a remote location.

Each entity will have established a nominal performance level for each Protection System communications channel that is consistent with proper functioning of the Protection System. If that level of nominal performance is not being met, the system will go into alarm. Following are some examples of Protection System communications channel performance measuring:

- For direct transfer trip using a frequency shift power line carrier channel, a guard level monitor is part of the equipment. A normal receive level is established when the system is calibrated and if the signal level drops below an established level, the system will indicate an alarm.
- An on-off blocking signal over power line carrier is used for directional comparison blocking schemes on transmission lines. During a Fault, block logic is sent to the remote relays by turning on a local transmitter and sending the signal over the power line to a receiver at the remote end. This signal is normally off so continuous levels cannot be checked. These schemes use check-back testing to determine channel performance. A

predetermined signal sequence is sent to the remote end and the remote end decodes this signal and sends a signal sequence back. If the sending end receives the correct information from the remote terminal, the test passes and no alarm is indicated. Full power and reduced power tests are typically run. Power levels for these tests are determined at the time of calibration.

- Pilot wire relay systems use a hardwire communications circuit to communicate between the local and remote ends of the protective zone. This circuit is monitored by circulating a dc current between the relay systems. A typical level may be 1 mA. If the level drops below the setting of the alarm monitor, the system will indicate an alarm.
- Modern digital relay systems use data communications to transmit relay information to the remote end relays. An example of this is a line current differential scheme commonly used on transmission lines. The protective relays communicate current magnitude and phase information over the communications path to determine if the Fault is located in the protective zone. Quantities such as digital packet loss, bit error rate and channel delay are monitored to determine the quality of the channel. These limits are determined and set during relay commissioning. Once set, any channel quality problems that fall outside the set levels will indicate an alarm.

The previous examples show how some protective relay communications channels can be monitored and how the channel performance can be compared to performance criteria established by the entity. This standard does not state what the performance criteria will be; it just requires that the entity establish nominal criteria so Protection System channel monitoring can be performed.

How is the performance criteria of Protection System communications equipment involved in the maintenance program?

An entity determines the acceptable performance criteria, depending on the technology implemented. If the communications channel performance of a Protection System varies from the pre-determined performance criteria for that system, then these results should be investigated and resolved.

How do I verify the A/D converters of microprocessor-based relays?

There are a variety of ways to do this. Two examples would be: using values gathered via data communications and automatically comparing these values with values from other sources, or using groupings of other measurements (such as vector summation of bus feeder currents) for comparison. Many other methods are possible.

15.6 Alarms (Table 2)

In addition to the tables of maintenance for the components of a Protection System, there is an additional table added for alarms. This additional table was added for clarity. This enabled the common alarm attributes to be consolidated into a single spot, and, thus, make it easier to read the Tables 1-1 through 1-5, Table 3, and Table 4. The alarms need to arrive at a site wherein a corrective action can be initiated. This could be a control room, operations center, etc. The alarming mechanism can be a standard alarming system or an auto-polling system; the only requirement is that the alarm be brought to the action-site within 24 hours. This effectively makes manned-stations equivalent to monitored stations. The alarm of a monitored point (for example a monitored trip path with a lamp) in a manned-station now makes that monitored point eligible for monitored status. Obviously, these same rules apply to a non-manned-station, which

is that if the monitored point has an alarm that is auto-reported to the operations center (for example) within 24 hours, then it too is considered monitored.

15.6.1 Frequently Asked Questions:

Why are there activities defined for varying degrees of monitoring a Protection System component when that level of technology may not yet be available?

There may already be some equipment available that is capable of meeting the highest levels of monitoring criteria listed in the Tables. However, even if there is no equipment available today that can meet this level of monitoring the standard establishes the necessary requirements for when such equipment becomes available. By creating a roadmap for development, this provision makes the standard technology neutral. The Standard Drafting Team wants to avoid the need to revise the standard in a few years to accommodate technology advances that may be coming to the industry.

Does a fail-safe “form b” contact that is alarmed to a 24/7 operation center classify as an alarm path with monitoring?

If the fail-safe “form-b” contact that is alarmed to a 24/7 operation center causes the alarm to activate for failure of any portion of the alarming path from the alarm origin to the 24/7 operations center, then this can be classified as an alarm path with monitoring.

15.7 Distributed UFLS and Distributed UVLS Systems (Table 3)

Distributed UFLS and distributed UVLS systems have their maintenance activities documented in Table 3 due to their distributed nature allowing reduced maintenance activities and extended maximum maintenance intervals. Relays have the same maintenance activities and intervals as Table 1-1. Voltage and current-sensing devices have the same maintenance activity and interval as Table 1-3. DC systems need only have their voltage read at the relay every 12 years. Control circuits have the following maintenance activities every 12 years:

- Verify the trip path between the relay and lock-out and/or auxiliary tripping device(s).
- Verify operation of any lock-out and/or auxiliary tripping device(s) used in the trip circuit.
- No verification of trip path required between the lock-out (and/or auxiliary tripping device) and the non-BES interrupting device.
- No verification of trip path required between the relay and trip coil for circuits that have no lock-out and/or auxiliary tripping device(s).
- No verification of trip coil required.

No maintenance activity is required for associated communication systems for distributed UFLS and distributed UVLS schemes.

Non-BES interrupting devices that participate in a distributed UFLS or distributed UVLS scheme are excluded from the tripping requirement, and part of the control circuit test requirement; however, the part of the trip path control circuitry between the Load-Shed relay and lock-out or auxiliary tripping relay must be tested at least once every 12 years. In the case where there is no lock-out or auxiliary tripping relay used in a distributed UFLS or UVLS scheme which is not part of the BES, there is no control circuit test requirement. There are many circuit interrupting devices in the distribution system that will be operating for any given under-frequency event

that requires tripping for that event. A failure in the tripping action of a single distributed system circuit breaker (or non-BES equipment interruption device) will be far less significant than, for example, any single transmission Protection System failure, such as a failure of a bus differential lock-out relay. While many failures of these distributed system circuit breakers (or non-BES equipment interruption device) could add up to be significant, it is also believed that many circuit breakers are operated often on just Fault clearing duty; and, therefore, these circuit breakers are operated at least as frequently as any requirements that appear in this standard.

There are times when a Protection System component will be used on a BES device, as well as a non-BES device, such as a battery bank that serves both a BES circuit breaker and a non-BES interrupting device used for UFLS. In such a case, the battery bank (or other Protection System component) will be subject to the Tables of the standard because it is used for the BES.

15.7.1 Frequently Asked Questions:

The standard reaches further into the distribution system than we would like for UFLS and UVLS

While UFLS and UVLS equipment are located on the distribution network, their job is to protect the Bulk Electric System. This is not beyond the scope of NERC's Section 215 authority.

FPA section 215(a) definitions section defines bulk power system as: "(A) facilities and control Systems necessary for operating an interconnected electric energy transmission network (or any portion thereof)." That definition, then, is limited by a later statement which adds the term bulk power system "...does not include facilities used in the local distribution of electric energy." Also, Section 215 also covers users, owners, and operators of bulk power Facilities.

UFLS and UVLS (when the UVLS is installed to prevent system voltage collapse or voltage instability for BES reliability) are not "used in the local distribution of electric energy," despite their location on local distribution networks. Further, if UFLS/UVLS Facilities were not covered by the reliability standards, then in order to protect the integrity of the BES during under-frequency or under-voltage events, that Load would have to be shed at the Transmission bus to ensure the Load-generation balance and voltage stability is maintained on the BES.

15.8 Automatic Reclosing (Table 4)

Please see the document referenced in Section F of PRC-005-3, "Considerations for Maintenance and Testing of Autoreclosing Schemes — November 2012", for a discussion of Automatic Reclosing as addressed in PRC-005-3.

15.8.1 Frequently-asked Questions

Automatic Reclosing is a control, not a protective function; why then is Automatic Reclosing maintenance included in the Protection System Maintenance Program (PSMP)?

Automatic Reclosing is a control function. The standard's title 'Protection System and Automatic Reclosing Maintenance' clearly distinguishes (separates) the Automatic Reclosing from the Protection System. Automatic Reclosing is included in the PSMP because it is a more pragmatic approach as compared to creating a parallel and essentially identical 'Control System Maintenance Program' for the Automatic Reclosing component types.

When do I need to have the initial maintenance of Automatic Reclosing Components completed upon change of the largest BES generating unit in the BA/RSG?

The maintenance interval, for newly identified Automatic Reclosing Components, starts when a change in the largest BES generating unit is determined by the BA/RSG. The first maintenance records for newly identified Automatic Reclosing Components should be dated no later than the maximum maintenance interval after the identification date. The maximum maintenance intervals for each newly identified Component are defined in Table 4. No activities or records are required prior to the date of identification.

Our maintenance practice consists of initiating the Automatic Reclosing relay and confirming the breaker closes properly and the close signal is released. This practice verifies the control circuitry associated with Automatic Reclosing. Do you agree?"

The described task partially verifies the control circuit maintenance activity. To meet the control circuit maintenance activity, responsible entities need to verify, *upon initiation*, that the reclosing relay does not issue a *premature closing command*. As noted on page 12 of the SAMS/SPCS report, the concern being addressed within the standard is premature auto reclosing that has the potential to cause generating unit or plant instability. Reclosing applications have many variations, responsible entities will need to verify the applicability of associated supervision/conditional logic and the reclosing relay operation; then verify the conditional logic or that the reclosing relay performs in a manner that does not result in a *premature closing command* being issued.

Some examples of conditions which can result in a premature closing command are: an improper supervision or conditional logic input which provides a false state and allows the reclosing relay to issue an improper close command based on incorrect conditions (i.e. voltage supervision, equipment status, sync window verification); timers utilized for closing actuation or reclosing arming/disarming circuitry which could allow the reclosing relay to issue an improper close command; a reclosing relay output contact failure which could result in a made-up-close condition / failure-to-release condition.

Why was a close-in three phase fault present for twice the normal clearing time chosen for the Automatic Reclosing exclusion? It exceeds TPL requirements and ignores the breaker closing time in a trip-close-trip sequence, thus making the exclusion harder to attain.

This condition represents a situation where a close signal is issued with no time delay or with less time delay than is intended, such as if a reclosing contact is welded closed. This failure mode can result in a minimum trip-close-trip sequence with the two faults cleared in primary protection operating time, and the open time between faults equal to the breaker closing cycle time. The sequence for this failure mode results in system impact equivalent to a high-speed autoreclosing sequence with no delay added in the autoreclosing logic. It represents a failure mode which must be avoided because it exceeds TPL requirements.

Do we have to test the various breaker closing circuit interlocks and controls such as anti-pump?

These components are not specifically addressed within Table 4, and need not be individually tested.

For Automatic Reclosing that is not part of an RAS, do we have to close the circuit breaker periodically?

No--for this application, you need only to verify that the Automatic Reclosing, upon initiation, does not issue a premature closing command. This activity is concerned only with assuring that a premature close does not occur, and cause generating plant instability.

For Automatic Reclosing that is part of an RAS, do we have to close the circuit breaker periodically?

Yes--in this application, successful closing is a necessary portion of the RAS, and must be verified.

Why is maintenance of supervisory relays now included in PRC-005 for Automatic Reclosing?

Proper performance of supervising relays supports the reliability of the BES because some conditions can result in a premature closing command. An example of this would be an improper supervision or conditional logic input which provides a false state and allows the reclosing relay to issue an improper close command based on incorrect conditions (i.e. voltage supervision, sync window verification)

My reclosing circuitry contains the following inputs listed below.

- **79/ON – Supervisory contact which turns Automatic Reclosing ON or OFF**
- **52 – Supervisory contact which provides breaker indication (“b” contact)**
- **86 - Supervisory contact from a lockout relay**
- **79 – Supervisory contact from a reclosing relay**
- **25 – Supervisory contact from a sync-check relay**
- **27 or 59 – Supervisory contact from an undervoltage or overvoltage relay**

Which parts of the control circuitry would need to be verified, upon initiation, do not issue a premature close command per PRC-005?

Supervisory Relays are defined in this standard as “relay(s) that perform voltage and/or sync check functions that enables or disables operation of the reclosing relay.” The 79, 25, and 27 or 59 would need to be verified because they are supervisory devices that are associated with Automatic Reclosing. The 79/ON, 52, and 86 would not need to be verified.

The sync check and voltage check functions are part of my microprocessor reclosing relay. Are there any test requirements for these internal supervisory functions?

A microprocessor reclosing relay that is using internal sync check or voltage check supervisory functions is a combinational reclosing and supervisory relay (i.e. 79/25).). The maintenance activities for both a reclosing relay and supervisory relay would apply. The voltage sensing devices providing input to a combinational reclosing and supervisory relay would require the activities in Table 4-3.

Is it necessary to verify the close signal operates the breaker?

Only when the control circuitry associated with automatic reclosing is a part of a RAS, then all paths that are essential for proper operation of the RAS must be verified, per table 4-2(b).

15.9 Sudden Pressure Relaying (Table 5)

Please see the document referenced in Section F of PRC-005-6, “Sudden Pressure Relays and Other Devices that Respond to Non-Electrical Quantities – December 2013”, for a discussion of Sudden Pressure Relaying as addressed in PRC-005-6.

15.9.1 Frequently Asked Questions:

How do I verify the pressure or flow sensing mechanism is operable?

Maintenance activities for the fault pressure relay associated with Sudden Pressure Relaying in PRC-005-6 are intended to verify that the pressure and/or flow sensing mechanism are functioning correctly. Beyond this, PRC-005-6 requires no calibration (adjusting the operating threshold or measurement accuracy of a measuring element to meet the intended performance requirement) or testing (applying signals to a component to observe functional performance or output behavior, or to diagnose problems) activities. For example, some designs of flow sensing mechanisms allow the operation of a test switch to actuate the limit switch of the flow sensing mechanism. Operation of this test switch and verification of the flow sensing mechanism would meet the requirements of the maintenance activity. Another example involves a gas pressure sensing mechanism which is isolated by a test plug. Removal of the plug and verification of the bellows mechanism would meet the requirements of the maintenance activity.

Why the 6-year maximum maintenance interval for fault pressure relays?

The SDT established the six-year maintenance interval for fault pressure relays (see Table 5, PRC-005-6) based on the recommendation of the System Protection and Control Subcommittee (SPCS). The technical experts of the SPCS were tasked with developing the technical documents to:

- i. Describe the devices and functions (to include sudden pressure relays which trip for fault conditions) that should address FERC’s concern; and
- ii. Propose minimum maintenance activities for such devices and maximum maintenance intervals, including the technical basis for each.

Excerpt from the [SPCS technical report](#): “In order to determine present industry practices related to sudden pressure relay maintenance, the SPCS conducted a survey of Transmission Owners and Generator Owners in all eight Regions requesting information related to their maintenance practices.” The SPCS received responses from 75 Transmission Owners and 109 Generator Owners. Note that, for the purpose of the survey, sudden pressure relays included the following: the “sudden pressure relay” (SPR) originally manufactured by Westinghouse, the “rapid pressure rise relay” (RPR) manufactured by Qualitrol, and a variety of Buchholz relays.

Table 2 provides a summary of the results of the responses:

Table 2: Sudden Pressure Relay Maintenance Practices – Survey Results		
	Transmission Owner	Generator Owner
Number of responding owners that trip with Sudden Pressure Relays:	67	84
Percentage of responding owners who trip that have a Maintenance Program:	75%	78%
Percentage of maintenance programs that include testing the pressure actuator:	81%	77%
Average Maintenance interval reported:	5.9 years	4.9 years

Additionally, in order to validate the information noted above, the SPCS contacted the following entities for their feedback: the IEEE Power System Relaying Committee, the IEEE Transformer Committee, the Doble Transformer Committee, the NATF System Protection Practices Group, and the EPRI Generator Owner/Operator Technical Focus Group. All of these organizations indicated the results of the SPCS survey are consistent with their respective experiences.

The SPCS discussed the potential difference between the recommended intervals for fault pressure relaying and intervals for transformer maintenance. The SPCS developed the recommended intervals for fault pressure relaying by comparing fault pressure relaying to Protection System Components with similar physical attributes. The SPCS recognized that these intervals may be shorter than some existing or future transformer maintenance intervals, but believed it to be more important to base intervals for fault pressure relaying on similar Protection System Components than transformer maintenance intervals.

The maintenance interval for fault pressure relays can be extended by utilizing performance-based maintenance thereby allowing entities that have maintenance intervals for transformers in excess of six years, to align them.

Sudden Pressure Relaying control circuitry is now specifically mentioned in the maintenance tables. Do we have to trip our circuit breaker specifically from the trip output of the sudden pressure relay?

No--verification may be by breaker tripping, but may be verified in overlapping segments with the Protection System control circuitry.

Can we use Performance Based Maintenance for fault pressure relays?

Yes--performance Based Maintenance is applicable to fault pressure relays.

15.10 Examples of Evidence of Compliance

To comply with the requirements of this standard, an entity will have to document and save evidence. The evidence can be of many different forms. The Standard Drafting Team recognizes

that there are concurrent evidence requirements of other NERC standards that could, at times, fulfill evidence requirements of this standard.

15.10.1 Frequently Asked Questions:

What forms of evidence are acceptable?

Acceptable forms of evidence, as relevant for the requirement being documented include, but are not limited to:

- Process documents or plans
- Data (such as relay settings sheets, photos, SCADA, and test records)
- Database lists, records and/or screen shots that demonstrate compliance information
- Prints, diagrams and/or schematics
- Maintenance records
- Logs (operator, substation, and other types of log)
- Inspection forms
- Mail, memos, or email proving the required information was exchanged, coordinated, submitted or received
- Check-off forms (paper or electronic)
- Any record that demonstrates that the maintenance activity was known, accounted for, and/or performed.

If I replace a failed Protection System component with another component, what testing do I need to perform on the new component?

In order to reset the Table 1 maintenance interval for the replacement component, all relevant Table 1 activities for the component should be performed.

I have evidence to show compliance for PRC-016 (“Special Protection System Misoperation”). Can I also use it to show compliance for this Standard, PRC-005-6?

Maintaining evidence for operation of Remedial Action Schemes could concurrently be utilized as proof of the operation of the associated trip coil (provided one can be certain of the trip coil involved). Thus, the reporting requirements that one may have to do for the Misoperation of a Special Protection Scheme under PRC-016 could work for the activity tracking requirements under this PRC-005-6.

I maintain Disturbance records which show Protection System operations. Can I use these records to show compliance?

These records can be concurrently utilized as dc trip path verifications, to the degree that they demonstrate the proper function of that dc trip path.

I maintain test reports on some of my Protection System components. Can I use these test reports to show that I have verified a maintenance activity?

Yes—the test reports may be used to demonstrate a verified maintenance activity.

References

1. [Protection System Maintenance: A Technical Reference](#). Prepared by the System Protection and Controls Task Force of the NERC Planning Committee. Dated September 13, 2007.
2. "Predicating The Optimum Routine test Interval For Protection Relays," by J. J. Kumm, M.S. Weber, D. Hou, and E. O. Schweitzer, III, IEEE Transactions on Power Delivery, Vol. 10, No. 2, April 1995.
3. "Transmission Relay System Performance Comparison For 2000, 2001, 2002, 2003, 2004 and 2005," Working Group I17 of Power System Relaying Committee of IEEE Power Engineering Society, May 2006.
4. "A Survey of Relaying Test Practices," Special Report by WG I11 of Power System Relaying Committee of IEEE Power Engineering Society, September 16, 1999.
5. "Transmission Protective Relay System Performance Measuring Methodology," Working Group I3 of Power System Relaying Committee of IEEE Power Engineering Society, January 2002.
6. "Processes, Issues, Trends and Quality Control of Relay Settings," Working Group C3 of Power System Relaying Committee of IEEE Power Engineering Society, December 2006.
7. "Proposed Statistical Performance Measures for Microprocessor-Based Transmission-Line Protective Relays, Part I - Explanation of the Statistics, and Part II - Collection and Uses of Data," Working Group D5 of Power System Relaying Committee of IEEE Power Engineering Society, May 1995; Papers 96WM 016-6 PWRD and 96WM 127-1 PWRD, 1996 IEEE Power Engineering Society Winter Meeting.
8. "Analysis And Guidelines For Testing Numerical Protection Schemes," Final Report of CIGRE WG 34.10, August 2000.
9. "Use of Preventative Maintenance and System Performance Data to Optimize Scheduled Maintenance Intervals," H. Anderson, R. Loughlin, and J. Zipp, Georgia Tech Protective Relay Conference, May 1996.
10. "Battery Performance Monitoring by Internal Ohmic Measurements" EPRI Application Guidelines for Stationary Batteries TR- 108826 Final Report, December 1997.
11. "IEEE Recommended Practice for Maintenance, Testing, and Replacement of Valve-Regulated Lead-Acid (VRLA) Batteries for Stationary Applications," IEEE Power Engineering Society Std 1188 – 2005.
12. "IEEE Recommended Practice for Maintenance, Testing, and Replacement of Vented Lead-Acid Batteries for Stationary Applications," IEEE Power & Engineering Society Std 45-2010.
13. "IEEE Recommended Practice for Installation design and Installation of Vented Lead-Acid Batteries for Stationary Applications," IEEE Std 484 – 2002.
14. "Stationary Battery Monitoring by Internal Ohmic Measurements," EPRI Technical Report, 1002925 Final Report, December 2002.
15. "Stationary Battery Guide: Design Application, and Maintenance" EPRI Revision 2 of TR-100248, 1006757, August 2002.

PSMT SDT References

16. "Essentials of Statistics for Business and Economics" Anderson, Sweeney, Williams, 2003
17. "Introduction to Statistics and Data Analysis" - Second Edition, Peck, Olson, Devore, 2005
18. "Statistical Analysis for Business Decisions" Peters, Summers, 1968
19. "Considerations for Maintenance and Testing of Autoreclosing Schemes," NERC System Analysis and Modeling Subcommittee and NERC System Protection and Control Subcommittee, November 2012

Figures

Figure 1: Typical Transmission System

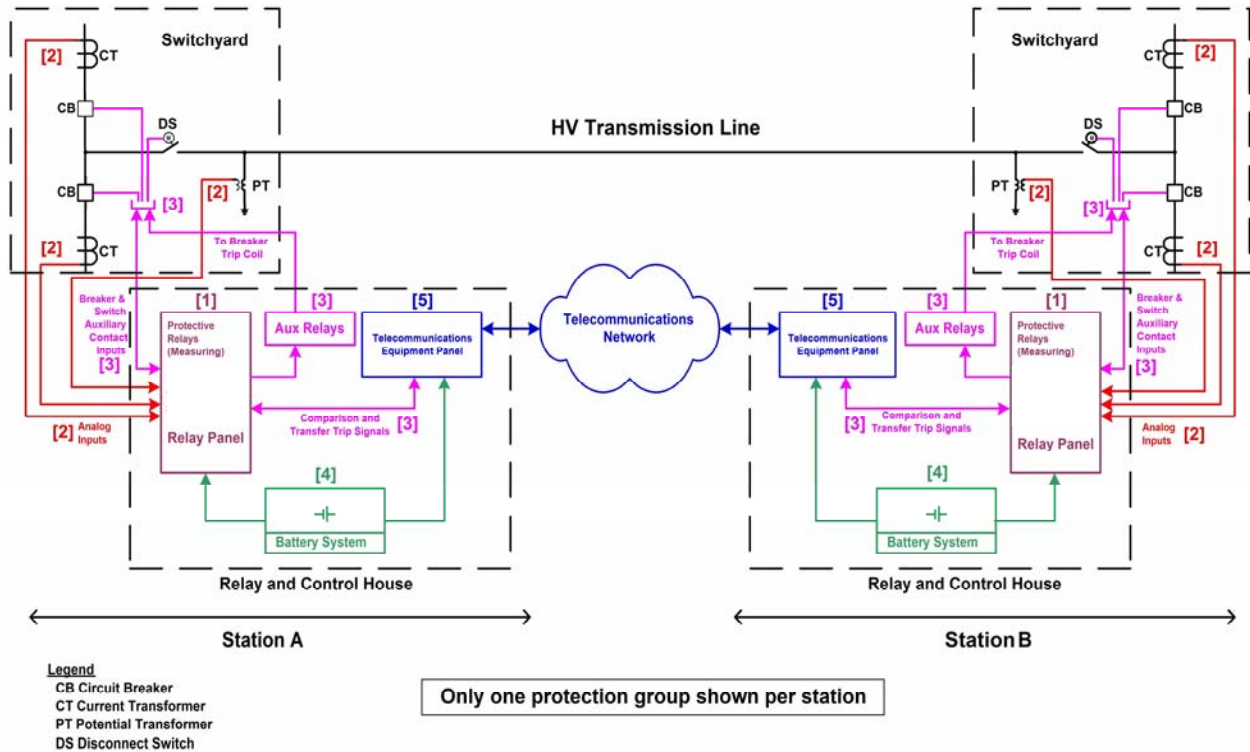

For information on components, see [Figure 1 & 2 Legend – components of Protection Systems](#)

Figure 2: Typical Generation System

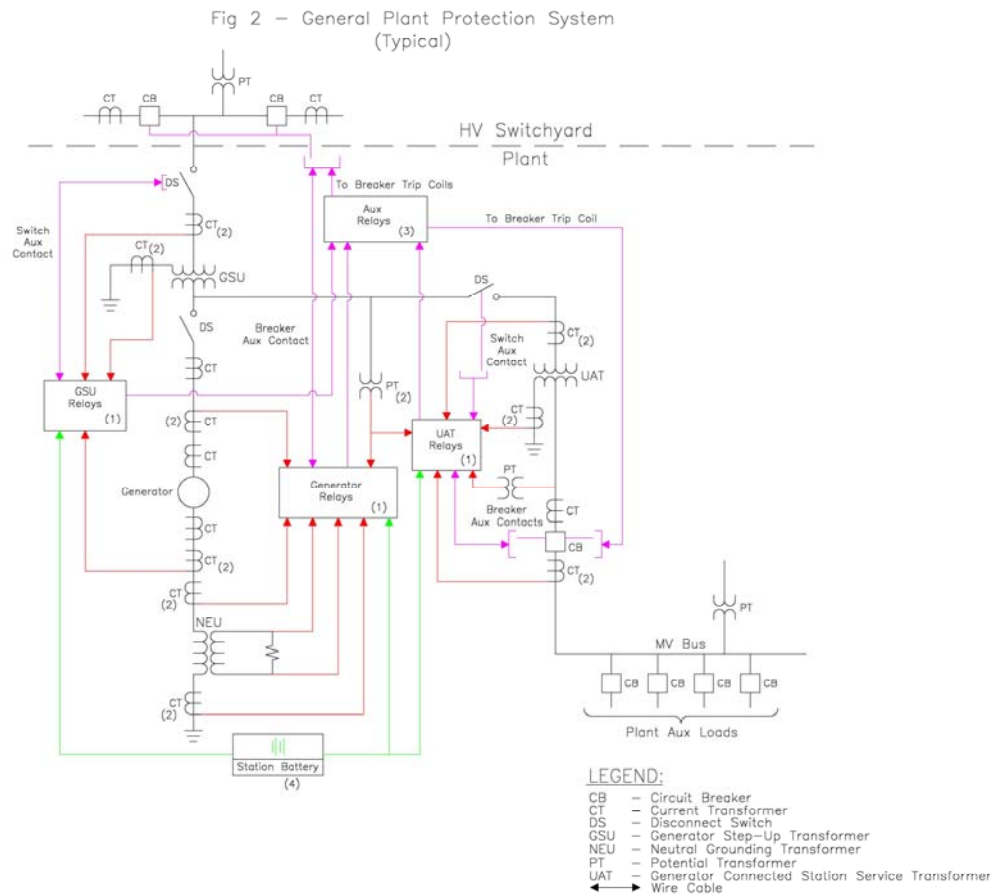

Note: Figure 2 may show elements that are not included within PRC-005-2, and also may not be all-inclusive; see the Applicability section of the standard for specifics.

For information on components, see [Figure 1 & 2 Legend – components of Protection Systems](#)

Figure 1 & 2 Legend – Components of Protection Systems

Number in Figure	Component of Protection System	Includes	Excludes
1	Protective relays which respond to electrical quantities	All protective relays that use current and/or voltage inputs from current & voltage sensors and that trip the 86, 94 or trip coil.	Devices that use non-electrical methods of operation including thermal, pressure, gas accumulation, and vibration. Any ancillary equipment not specified in the definition of Protection Systems. Control and/or monitoring equipment that is not a part of the automatic tripping action of the Protection System
2	Voltage and current sensing devices providing inputs to protective relays	The signals from the voltage & current sensing devices to the protective relay input.	Voltage & current sensing devices that are not a part of the Protection System, including sync-check systems, metering systems and data acquisition systems.
3	Control circuitry associated with protective functions	All control wiring (or other medium for conveying trip signals) associated with the tripping action of 86 devices, 94 devices or trip coils (from all parallel trip paths). This would include fiber-optic systems that carry a trip signal as well as hard-wired systems that carry trip current.	Closing circuits, SCADA circuits, other devices in control scheme not passing trip current
4	Station dc supply	Batteries and battery chargers and any control power system which has the function of supplying power to the protective relays, associated trip circuits and trip coils.	Any power supplies that are not used to power protective relays or their associated trip circuits and trip coils.
5	Communications systems necessary for correct operation of protective functions	Tele-protection equipment used to convey specific information, in the form of analog or digital signals, necessary for the correct operation of protective functions.	Any communications equipment that is not used to convey information necessary for the correct operation of protective functions.

[Additional information can be found in References](#)

Appendix A

The following illustrates the concept of overlapping verifications and tests as summarized in Section 10 of the paper. As an example, Figure A-1 shows protection for a critical transmission line by carrier blocking directional comparison pilot relaying. The goal is to verify the ability of the entire two-terminal pilot protection scheme to protect for line faults, and to avoid over-tripping for faults external to the transmission line zone of protection bounded by the current transformer locations.

Figure A-1

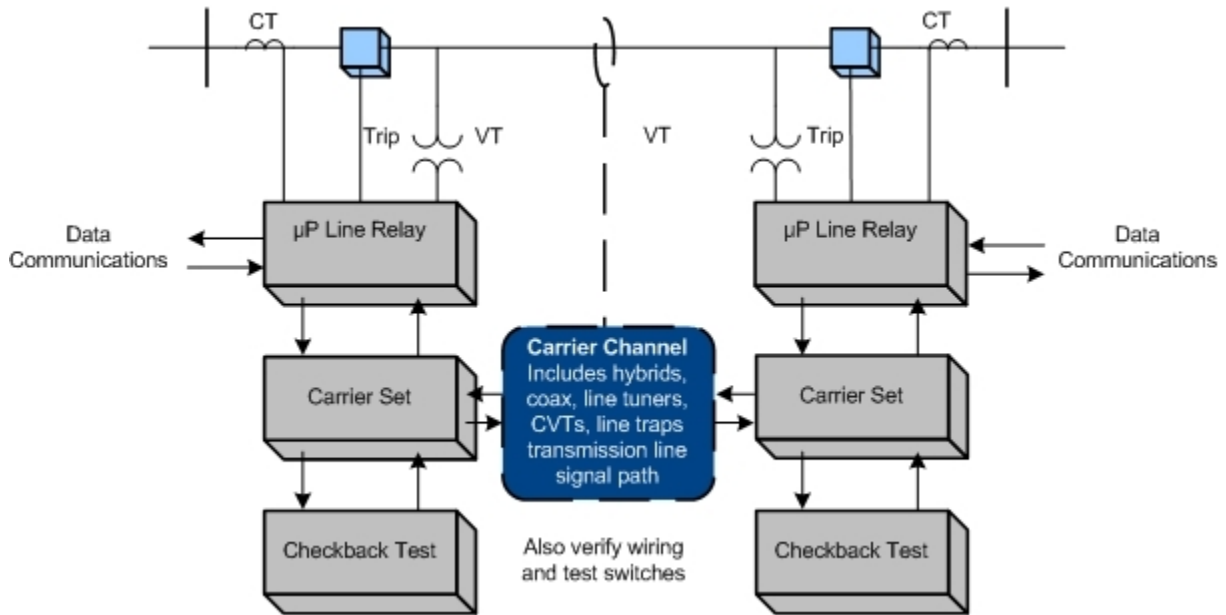

In this example (Figure A1), verification takes advantage of the self-monitoring features of microprocessor multifunction line relays at each end of the line. For each of the line relays themselves, the example assumes that the user has the following arrangements in place:

1. The relay has a data communications port that can be accessed from remote locations.
2. The relay has internal self-monitoring programs and functions that report failures of internal electronics, via communications messages or alarm contacts to SCADA.
3. The relays report loss of dc power, and the relays themselves or external monitors report the state of the dc battery supply.
4. The CT and PT inputs to the relays are used for continuous calculation of metered values of volts, amperes, plus watts and vars on the line. These metered values are reported by data communications. For maintenance, the user elects to compare these readings to those of other relays, meters, or DFRs. The other readings may be from redundant relaying or measurement systems or they may be derived from values in other protection zones. Comparison with other such readings to within required relaying accuracy verifies voltage and current sensing devices, wiring, and analog signal input processing of the relays. One

effective way to do this is to utilize the relay metered values directly in SCADA, where they can be compared with other references or state estimator values.

5. Breaker status indication from auxiliary contacts is verified in the same way as in (2). Status indications must be consistent with the flow or absence of current.
6. Continuity of the breaker trip circuit from dc bus through the trip coil is monitored by the relay and reported via communications.
7. Correct operation of the on-off carrier channel is also critical to security of the Protection System, so each carrier set has a connected or integrated automatic checkback test unit. The automatic checkback test runs several times a day. Newer carrier sets with integrated checkback testing check for received signal level and report abnormal channel attenuation or noise, even if the problem is not severe enough to completely disable the channel.

These monitoring activities plus the check-back test comprise automatic verification of all the Protection System elements that experience tells us are the most prone to fail. But, does this comprise a complete verification?

Figure A-2

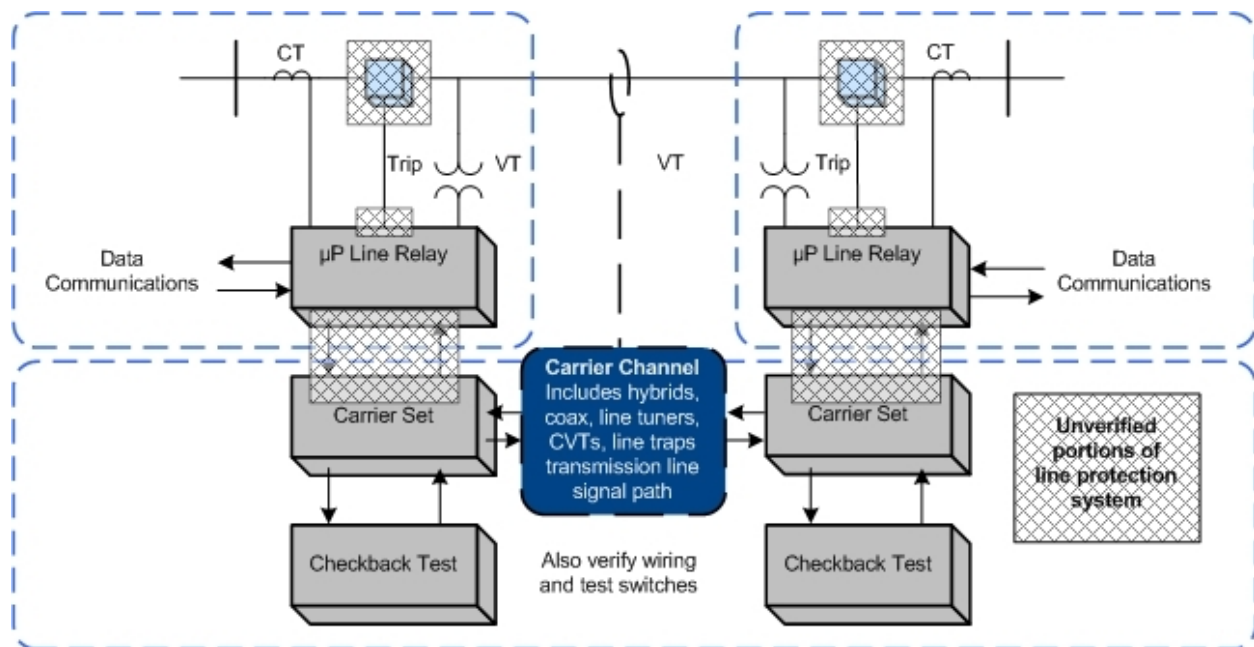

The dotted boxes of Figure A-2 show the sections of verification defined by the monitoring and verification practices just listed. These sections are not completely overlapping, and the shaded regions show elements that are not verified:

1. The continuity of trip coils is verified, but no means is provided for validating the ability of the circuit breaker to trip if the trip coil should be energized.

-
2. Within each line relay, all the microprocessors that participate in the trip decision have been verified by internal monitoring. However, the trip circuit is actually energized by the contacts of a small telephone-type "ice cube" relay within the line protective relay. The microprocessor energizes the coil of this ice cube relay through its output data port and a transistor driver circuit. There is no monitoring of the output port, driver circuit, ice cube relay, or contacts of that relay. These components are critical for tripping the circuit breaker for a Fault.
 3. The check-back test of the carrier channel does not verify the connections between the relaying microprocessor internal decision programs and the carrier transmitter keying circuit or the carrier receiver output state. These connections include microprocessor I/O ports, electronic driver circuits, wiring, and sometimes telephone-type auxiliary relays.
 4. The correct states of breaker and disconnect switch auxiliary contacts are monitored, but this does not confirm that the state change indication is correct when the breaker or switch opens.

A practical solution for (1) and (2) is to observe actual breaker tripping, with a specified maximum time interval between trip tests. Clearing of naturally-occurring Faults are demonstrations of operation that reset the time interval clock for testing of each breaker tripped in this way. If Faults do not occur, manual tripping of the breaker through the relay trip output via data communications to the relay microprocessor meets the requirement for periodic testing.

PRC-005-6 does not address breaker maintenance, and its Protection System test requirements can be met by energizing the trip circuit in a test mode (breaker disconnected) through the relay microprocessor. This can be done via a front-panel button command to the relay logic, or application of a simulated Fault with a relay test set. However, utilities have found that breakers often show problems during Protection System tests. It is recommended that Protection System verification include periodic testing of the actual tripping of connected circuit breakers.

Testing of the relay-carrier set interface in (3) requires that each relay key its transmitter, and that the other relay demonstrate reception of that blocking carrier. This can be observed from relay or DFR records during naturally occurring Faults, or by a manual test. If the checkback test sequence were incorporated in the relay logic, the carrier sets and carrier channel are then included in the overlapping segments monitored by the two relays, and the monitoring gap is completely eliminated.

Appendix B

Protection System Maintenance Standard Drafting Team

Charles W. Rogers
Chairman
Consumers Energy Co.

John B. Anderson
Xcel Energy

Stephen Crutchfield
NERC

Forrest Brock
Western Farmers Electric Cooperative

John Schecter
American Electric Power

Aaron Feathers
Pacific Gas and Electric Company

William D. Shultz
Southern Company Generation

Sam Francis
Oncor Electric Delivery

Scott Vaughan
City of Roseville Electric Department

James M. Kinney
FirstEnergy Corporation

Matthew Westrich
American Transmission Company

Kristina Marriott
ENOSERV

Philip B. Winston
Southern Company Transmission

Exhibit F

Consideration of Directives

Consideration of Directives

Project 2007-17.4 – PRC-005 Order 803 Directive

October 9, 2015

Project 2007-17.4 – PRC-005 Order 803 Directive

Issue or Directive	Source	Consideration of Issue or Directive
<p>In Order No. 803, FERC approved Standard PRC-005-3 and, in Paragraph 31, directed NERC to:</p> <p>"...direct that, pursuant to section 215(d)(5) of the FPA, NERC develop modifications to PRC-005-3 to include supervisory devices associated with auto reclosing relay schemes to which the Reliability Standard applies. Further, we clarify that NERC's proposal regarding the scope of supervisory devices is an acceptable approach to satisfy the Commission directive. Specifically, NERC proposed in its NOPR comments, and we find acceptable, that the scope of the supervisory devices to be encompassed in the Reliability Standard are those providing voltage supervision, supervisory inputs associated with selective auto-reclosing, and sync-check relays that are part of a reclosing scheme covered by PRC-005-3."</p>	<p>FERC Order 803 approving Reliability Standard PRC-005-3, Protection System and , Automatic Reclosing Maintenance</p>	<p>The Protection System Maintenance and Testing Standard Drafting Team (PSMTSDT) proposed revision of the standard specific defined terms "Automatic Reclosing" and "Component Type" as follows:</p> <p>Automatic Reclosing – Includes the following Components:</p> <ul style="list-style-type: none"> • Reclosing relay(s) • Supervisory relay(s) or function(s)– relay(s) or function(s) that perform voltage and/or sync check functions that enables or disables operation of the reclosing relay • Voltage sensing devices associated with the supervisory relay(s) or function(s) • Control circuitry associated with the reclosing relay or supervisory relay(s) or function(s) <p>Component Type –</p>

Project 2007-17.4 – PRC-005 Order 803 Directive

Issue or Directive	Source	Consideration of Issue or Directive
		<ul style="list-style-type: none"> • Any one of the five specific elements of a Protection System. • Any one of the four specific elements of Automatic Reclosing. • Any one of the two specific elements of Sudden Pressure Relaying. <p>The Rationales for “Automatic Relaying” and “Component Type” were also revised to reflect the proposed revisions to the defined terms above. Tables 4-1 and 4-2 were updated by adding “supervisory relay(s)” as appropriate. A new Table 4-3 was added to address maintenance activities and intervals for Automatic Reclosing with supervisory relays. No substantive revisions are being proposed for the Requirements of the standard. The only revisions to Requirements R1 and R3 included updating the Table numbering to reflect the addition of Table 4-3. The Violation Severity Levels (VSLs) were updated to reflect the Requirement language for R1 and R3. All references to table numbering throughout the standard have also been corrected to reflect the addition of Table 4-3. This proposed version of PRC-005 used PRC-005-5 developed under Project 2014-01 as the starting point for revisions to address the directive.</p>

Exhibit G

Analysis of Violation Risk Factors and Violation Severity Levels

Violation Risk Factor and Violation Severity Level Justifications

Project 2007-17.4 PRC-005-6

Protection System, Automatic Reclosing and Sudden Pressure Relaying Maintenance

Violation Risk Factor and Violation Severity Level Justifications

This document provides the drafting team's justification for assignment of violation risk factors (VRFs) and violation severity levels (VSLs) for each requirement in PRC-005-6 - Protection System, Automatic Reclosing and Sudden Pressure Relaying Maintenance.

Each primary requirement is assigned a VRF and a set of one or more VSLs. These elements support the determination of an initial value range for the Base Penalty Amount regarding violations of requirements in FERC-approved Reliability Standards, as defined in the ERO Sanction Guidelines.

The Protection System Maintenance and Testing Standard Drafting Team (SDT) applied the following NERC criteria and FERC Guidelines when proposing VRFs and VSLs for the requirements under this project:

NERC Criteria – VRFs

High Risk Requirement

A requirement that, if violated, could directly cause or contribute to bulk electric system instability, separation, or a cascading sequence of failures, or could place the bulk electric system at an unacceptable risk of instability, separation, or cascading failures; or, a requirement in a planning time frame that, if violated, could, under emergency, abnormal, or restorative conditions anticipated by the preparations, directly cause or contribute to bulk electric system instability, separation, or a cascading sequence of failures, or could place the bulk electric system at an unacceptable risk of instability, separation, or cascading failures, or could hinder restoration to a normal condition.

Medium Risk Requirement

A requirement that, if violated, could directly affect the electrical state or the capability of the bulk electric system, or the ability to effectively monitor and control the bulk electric system. However, violation of a medium risk requirement is unlikely to lead to bulk electric system instability, separation, or cascading failures; or, a requirement in a planning time frame that, if violated, could, under emergency, abnormal, or restorative conditions anticipated by the preparations, directly and adversely affect the electrical state or capability of the bulk electric system, or the ability to effectively monitor, control, or restore the bulk electric system. However, violation of a medium risk

requirement is unlikely, under emergency, abnormal, or restoration conditions anticipated by the preparations, to lead to bulk electric system instability, separation, or cascading failures, nor to hinder restoration to a normal condition.

Lower Risk Requirement

A requirement that is administrative in nature and a requirement that, if violated, would not be expected to adversely affect the electrical state or capability of the bulk electric system, or the ability to effectively monitor and control the bulk electric system; or, a requirement that is administrative in nature and a requirement in a planning time frame that, if violated, would not, under the emergency, abnormal, or restorative conditions anticipated by the preparations, be expected to adversely affect the electrical state or capability of the bulk electric system, or the ability to effectively monitor, control, or restore the bulk electric system. A planning requirement that is administrative in nature.

FERC VRF Guidelines

Guideline (1) – Consistency with the Conclusions of the Final Blackout Report

The Commission seeks to ensure that VRFs assigned to Requirements of Reliability Standards in these identified areas appropriately reflect their historical critical impact on the reliability of the Bulk-Power System.

In the VSL Order, FERC listed critical areas (from the Final Blackout Report) where violations could severely affect the reliability of the Bulk-Power System:

- Emergency operations
- Vegetation management
- Operator personnel training
- Protection systems and their coordination
- Operating tools and backup facilities
- Reactive power and voltage control
- System modeling and data exchange
- Communication protocol and facilities
- Requirements to determine equipment ratings
- Synchronized data recorders
- Clearer criteria for operationally critical facilities
- Appropriate use of transmission loading relief

Guideline (2) – Consistency within a Reliability Standard

The Commission expects a rational connection between the sub-Requirement VRF assignments and the main Requirement VRF assignment.

Guideline (3) — Consistency among Reliability Standards

The Commission expects the assignment of VRFs corresponding to Requirements that address similar reliability goals in different Reliability Standards would be treated comparably.

Guideline (4) — Consistency with NERC’s Definition of the VRF Level

Guideline (4) was developed to evaluate whether the assignment of a particular VRF level conforms to NERC’s definition of that risk level.

Guideline (5) — Treatment of Requirements that Co-mingle More Than One Obligation

Where a single Requirement co-mingles a higher risk reliability objective and a lesser risk reliability objective, the VRF assignment for such Requirements must not be watered down to reflect the lower risk level associated with the less important objective of the Reliability Standard.

The following discussion addresses how the SDT considered FERC’s VRF Guidelines 2 through 5. The team did not address Guideline 1 directly because of an apparent conflict between Guidelines 1 and 4. Whereas Guideline 1 identifies a list of topics that encompass nearly all topics within NERC’s Reliability Standards and implies that these requirements should be assigned a “High” VRF, Guideline 4 directs assignment of VRFs based on the impact of a specific requirement to the reliability of the system. The SDT believes that Guideline 4 is reflective of the intent of VRFs in the first instance and therefore concentrated its approach on the reliability impact of the requirements.

PRC-005-6 Protection System, Automatic Reclosing and Sudden Pressure Relaying Maintenance is a revision of PRC-005-3 Protection System and Automatic Reclosing Maintenance with the stated purpose: To document and implement programs for the maintenance of all Protection Systems, Automatic Reclosing, and Sudden Pressure Relaying affecting the reliability of the Bulk Electric System (BES) so that they are kept in working order.

PRC-005-6 has five (5) requirements that address the inclusion of Sudden Pressure Relaying. A Table of minimum maintenance activities and maximum maintenance intervals for Sudden Pressure Relaying has been added to PRC-005-3 to address FERC’s directives from Order 758. The revised standard requires that entities develop an appropriate Protection System Maintenance Program (PSMP), that they implement their PSMP, and that, in the event they are unable to restore Sudden Pressure Relaying Components to proper working order while performing maintenance, they initiate the follow-up activities necessary to resolve those maintenance issues.

The requirements of PRC-005-6 map one-to-one with the requirements of PRC-005-3. The drafting team did not revise the VRFs for the requirements of PRC-005-3 in PRC-005-6.

PRC-005-6 Requirements R1 and R2 are related to developing and documenting a Protection System Maintenance Program. The SDT determined that the assignment of a VRF of Medium was consistent with the NERC criteria that violations of these requirements could directly affect the electrical state or the capability of the bulk electric system, or the ability to effectively monitor and control the bulk electric system but are unlikely to lead to bulk electric system instability, separation, or cascading failures. Additionally, a review of the body of existing NERC Standards with approved VRFs revealed

that requirements with similar reliability objectives in other standards are largely assigned a VRF of Medium.

PRC-005-6 Requirements R3 and R4 are related to implementation of the Protection System Maintenance Program. The SDT determined that the assignment of a VRF of High was consistent with the NERC criteria that that violation of these requirements could directly cause or contribute to bulk electric system instability, separation, or a cascading sequence of failures, or could place the bulk electric system at an unacceptable risk of instability, separation, or cascading failures. Additionally, a review of the body of existing NERC Standards with approved VRFs revealed that requirements with similar reliability objectives in other standards are assigned a VRF of High.

PRC-005-6 Requirement R5 relates to the initiation of actions resulting in resolution of unresolved maintenance issues, which describe situations where an entity was unable to restore a Component to proper working order during the performance of the maintenance activity. The SDT determined that the assignment of a VRF of Medium was consistent with the NERC criteria that violation of this requirements could directly affect the electrical state or the capability of the bulk electric system, or the ability to effectively monitor and control the bulk electric system but are unlikely to lead to bulk electric system instability, separation, or cascading failures. Additionally, a review of the body of existing NERC Standards with approved VRFs revealed that requirements with similar reliability objectives in other standards are largely assigned a VRF of Medium.

NERC Criteria - VSLs

VSLs define the degree to which compliance with a requirement was not achieved. Each requirement must have at least one VSL. While it is preferable to have four VSLs for each requirement, some requirements do not have multiple “degrees” of noncompliant performance and may have only one, two, or three VSLs.

VSLs should be based on the guidelines shown in the table below:

Lower	Moderate	High	Severe
<p>Missing a minor element (or a small percentage) of the required performance</p> <p>The performance or product measured has significant value as it almost meets the full intent of the requirement.</p>	<p>Missing at least one significant element (or a moderate percentage) of the required performance.</p> <p>The performance or product measured still has significant value in meeting the intent of the requirement.</p>	<p>Missing more than one significant element (or is missing a high percentage) of the required performance or is missing a single vital Component.</p> <p>The performance or product has limited value in meeting the intent of the requirement.</p>	<p>Missing most or all of the significant elements (or a significant percentage) of the required performance.</p> <p>The performance measured does not meet the intent of the requirement or the product delivered cannot be used in meeting the intent of the requirement.</p>

FERC Order on VSLs

In its June 19, 2008 Order¹ on VSLs, FERC indicated it would use the following four guidelines² for determining whether to approve VSLs:

Guideline 1: VSL Assignments Should Not Have the Unintended Consequence of Lowering the Current Level of Compliance

- Compare the VSLs to any prior Levels of Non-compliance and avoid significant changes that may encourage a lower level of compliance than was required when Levels of Non-compliance were used.

Guideline 2: VSL Assignments Should Ensure Uniformity and Consistency in the Determination of Penalties

- Guideline 2a: A violation of a “binary” type requirement must be a “Severe” VSL.
- Guideline 2b: Do not use ambiguous terms such as “minor” and “significant” to describe noncompliant performance.

Guideline 3: VSL Assignment Should Be Consistent with the Corresponding Requirement

- VSLs should not expand on what is required in the requirement.

Guideline 4: VSL Assignment Should Be Based on A Single Violation, Not on A Cumulative Number of Violations

- . . . unless otherwise stated in the requirement, each instance of non-compliance with a requirement is a separate violation. Section 4 of the Sanction Guidelines states that assessing penalties on a per violation per day basis is the “default” for penalty calculations.

¹ *Order on Violation Severity Levels Proposed by the Electric Reliability Organization*, 125 FERC ¶61,248 (2008).

² *Id.* at P 17.

VRF and VSL Justifications

VRF and VSL Justifications – PRC-005-6, R1	
Proposed VRF	Medium
NERC VRF Discussion	Failure to establish a Protection System Maintenance Program (PSMP) for Protection Systems designed to provide protection for BES Element(s) could directly affect the electrical state or the capability of the bulk power system. However, violation of this requirement is unlikely to lead to bulk power system instability, separation, or cascading failures. The applicable entities are always responsible for maintaining the reliability of the bulk power system regardless of the situation. This VRF emphasizes the risk to system performance that results from mal-performing Protection System Components. Failure to establish a PSMP for Protection Systems will not, by itself, lead to instability, separation, or cascading failures. Thus, the requirement meets NERC’s criteria for a Medium VRF.
FERC VRF G1 Discussion	Guideline 1- Consistency w/ Blackout Report: N/A
FERC VRF G2 Discussion	Guideline 2- Consistency within a Reliability Standard: The requirement has no sub-requirements so only one VRF was assigned. The requirement utilizes Parts to identify the items to be included within a PSMP. The VRF for this requirement is consistent with others in the standard with regard to relative risk; therefore, there is no conflict.
FERC VRF G3 Discussion	Guideline 3- Consistency among Reliability Standards: The SDT has determined that there is no consistency among existing approved Standards relative to requirements of this nature. The SDT has assigned a MEDIUM VRF, which is consistent with recent FERC guidance on FAC-008-3 Requirement R2 and FAC-013-2 Requirement R1, which are similar in nature to PRC-005-6 Requirement R1.

VRF and VSL Justifications – PRC-005-6, R1			
Proposed VRF	Medium		
FERC VRF G4 Discussion	<p>Guideline 4- Consistency with NERC Definitions of VRFs:</p> <p>Failure to establish a PSMP for Protection Systems designed to provide protection for BES Element(s) could directly affect the electrical state or the capability of the bulk power system. However, violation of this requirement is unlikely to lead to bulk power system instability, separation, or cascading failures. The applicable entities are always responsible for maintaining the reliability of the bulk power system regardless of the situation. This VRF emphasizes the risk to system performance that results from mal-performing Protection System Components. Failure to establish a PSMP for Protection Systems will not, by itself, lead to instability, separation, or cascading failures. Thus, the requirement meets NERC’s criteria for a Medium VRF.</p>		
FERC VRF G5 Discussion	<p>Guideline 5- Treatment of Requirements that Co-mingle More than One Obligation:</p> <p>This requirement establishes a single risk-level, and the assigned VRF is consistent with that risk level.</p>		
Proposed VSL – PRC-005-6, R1			
Lower	Moderate	High	Severe
The entity’s PSMP failed to specify whether one Component Type is being addressed by time-based or performance-based maintenance, or a combination of both. (Part 1.1)	The entity’s PSMP failed to specify whether two Component Types are being addressed by time-based or performance-based maintenance, or a combination of both. (Part 1.1)	The entity’s PSMP failed to specify whether three Component Types are being addressed by time-based or performance-based maintenance, or a combination of both. (Part 1.1). OR	The entity failed to establish a PSMP. OR The entity’s PSMP failed to specify whether four or more Component Types are being addressed by time-based or performance-based maintenance, or a combination of both. (Part 1.1).

Proposed VSL – PRC-005-6, R1			
Lower	Moderate	High	Severe
		<p>The entity’s PSMP failed to include the applicable monitoring attributes applied to each Component Type consistent with the maintenance intervals specified in Tables 1-1 through 1-5, Table 2, Table 3, Table 4-1 through 4-3, and Table 5 where monitoring is used to extend the maintenance intervals beyond those specified for unmonitored Components. (Part 1.2).</p>	<p>OR</p> <p>The entity’s PSMP failed to include applicable station batteries in a time-based program (Part 1.1)</p>

VRF and VSL Justifications – PRC-005-6, R1	
NERC VSL Guidelines	Meets NERC’s VSL Guidelines—There is an incremental aspect that the violation and the VSLs follow the guidelines for incremental violations.
FERC VSL G1 VSL Assignments Should Not Have the Unintended Consequence of Lowering the Current Level of Compliance	This VSL is consistent with the current VSLs associated with the existing requirements of the standards being replaced by this proposed standard.
FERC VSL G2 VSL Level Assignments Should Ensure Uniformity and Consistency in the Determination of Penalties Guideline 2a: The Single VSL Assignment Category for "Binary" Requirements Is Not Consistent Guideline 2b: VSL Assignments that Contain Ambiguous Language	Guideline 2a: N/A Guideline 2b: The proposed VSL does not use any ambiguous terminology, thereby supporting uniformity and consistency in the determination of similar penalties for similar violations.

VRF and VSL Justifications – PRC-005-6, R1

FERC VSL G3 VSL Assignment Should Be Consistent with the Corresponding Requirement	The proposed VSL uses similar terminology to that used in the associated requirement and is, therefore, consistent with the requirement.
FERC VSL G4 VSL Assignment Should Be Based on A Single Violation, Not on A Cumulative Number of Violations	The VSL is based on a single violation and not cumulative violations.

VRF and VSL Justifications – PRC-005-6, R2	
Proposed VRF	Medium
NERC VRF Discussion	Failure to properly establish a performance-based PSMP for Protection Systems designed to provide protection for BES Element(s) could directly affect the electrical state or the capability of the bulk power system. However, violation of this requirement is unlikely to lead to bulk power system instability, separation, or cascading failures. The applicable entities are always responsible for maintaining the reliability of the bulk power system regardless of the situation. This VRF emphasizes the risk to system performance that results from mal-performing Protection System Components. Failure to properly establish a performance-based PSMP for Protection Systems will not, by itself, lead to instability, separation, or cascading failures. Thus, the requirement meets NERC’s criteria for a Medium VRF.
FERC VRF G1 Discussion	Guideline 1- Consistency w/ Blackout Report: N/A
FERC VRF G2 Discussion	Guideline 2- Consistency within a Reliability Standard: The requirement has no subpart(s); therefore, only one VRF was assigned and no conflict(s) exist.
FERC VRF G3 Discussion	Guideline 3- Consistency among Reliability Standards: The SDT has determined that there is no consistency among existing approved Standards relative to requirements of this nature. The SDT has assigned a MEDIUM VRF, which is consistent with recent FERC guidance on FAC-008-3 Requirement R2 and FAC-013-2 Requirement R1, which are similar in nature to PRC-005-6 Requirement R1.
FERC VRF G4 Discussion	Guideline 4- Consistency with NERC Definitions of VRFs: Failure to properly establish a performance-based PSMP for.

VRF and VSL Justifications – PRC-005-6, R2			
Proposed VRF	Medium		
	Protection Systems designed to provide protection for BES Element(s) could directly affect the electrical state or the capability of the bulk power system. However, violation of this requirement is unlikely to lead to bulk power system instability, separation, or cascading failures. The applicable entities are always responsible for maintaining the reliability of the bulk power system regardless of the situation. This VRF emphasizes the risk to system performance that results from mal-performing Protection System Components. Failure to properly establish a performance-based PSMP for Protection Systems will not, by itself, lead to instability, separation, or cascading failures. Thus, the requirement meets NERC’s criteria for a Medium VRF.		
FERC VRF G5 Discussion	Guideline 5- Treatment of Requirements that Co-mingle More than One Obligation: This requirement establishes a single risk-level, and the assigned VRF is consistent with that risk level.		
Proposed VSL – PRC-005-6, R2			
Lower	Moderate	High	Severe
The entity uses performance-based maintenance intervals in its PSMP but failed to reduce Countable Events to no more than 4% within three years.	N/A	The entity uses performance-based maintenance intervals in its PSMP but failed to reduce Countable Events to no more than 4% within four years.	The entity uses performance-based maintenance intervals in its PSMP but: 1) Failed to establish the technical justification described within Requirement R2 for the initial use of the performance-based PSMP

Proposed VSL – PRC-005-6, R2			
Lower	Moderate	High	Severe
			<p>OR</p> <p>2) Failed to reduce countable events to no more than 4% within five years</p> <p>OR</p> <p>3) Maintained a Segment with less than 60 Components</p> <p>OR</p> <p>4) Failed to:</p> <ul style="list-style-type: none"> • Annually update the list of Components, <p>OR</p> <ul style="list-style-type: none"> • Annually perform maintenance on the greater of 5% of the Segment population or 3 Components, <p>OR</p> <ul style="list-style-type: none"> • Annually analyze the program activities and results for each Segment.

VRF and VSL Justifications – PRC-005-6, R2	
NERC VSL Guidelines	Meets NERC’s VSL Guidelines—There is an incremental aspect that the violation and the VSLs follow the guidelines for incremental violations.
FERC VSL G1 VSL Assignments Should Not Have the Unintended Consequence of Lowering the Current Level of Compliance	This VSL is consistent with the current VSLs associated with the existing requirements of the standards being replaced by this proposed standard.
FERC VSL G2 VSL Assignments Should Ensure Uniformity and Consistency in the Determination of Penalties Guideline 2a: The Single VSL Assignment Category for "Binary" Requirements Is Not Consistent	Guideline 2a: N/A Guideline 2b: The proposed VSL does not use any ambiguous terminology, thereby supporting uniformity and consistency in the determination of similar penalties for similar violations.

VRF and VSL Justifications – PRC-005-6, R2

Guideline 2b: VSL Assignments that Contain Ambiguous Language	
FERC VSL G3 VSL Assignment Should Be Consistent with the Corresponding Requirement	The proposed VSL uses similar terminology to that used in the associated requirement and is, therefore, consistent with the requirement.
FERC VSL G4 VSL Assignment Should Be Based on A Single Violation, Not on A Cumulative Number of Violations	The VSL is based on a single violation and not cumulative violations.

VRF and VSL Justifications – PRC-005-6, R3	
Proposed VRF	High
NERC VRF Discussion	Failure to implement and follow its PSMP could, under emergency, abnormal, or restorative conditions anticipated by the preparations, directly cause or contribute to bulk electric system instability, separation, or a cascading sequence of failures, or could place the bulk electric system at an unacceptable risk of instability, separation, or cascading failures, or could hinder restoration to a normal condition. Thus, this requirement meets the criteria for a High VRF.
FERC VRF G1 Discussion	Guideline 1- Consistency w/ Blackout Report: N/A
FERC VRF G2 Discussion	Guideline 2- Consistency within a Reliability Standard: The requirement has no subpart(s); therefore, only one VRF was assigned and no conflict(s) exist.
FERC VRF G3 Discussion	Guideline 3- Consistency among Reliability Standards: The only Reliability Standards with similar goals are those being replaced by this standard, and the High VRF assignment for this requirement is consistent with the assigned VRFs for companion requirements in those existing standards.
FERC VRF G4 Discussion	Guideline 4- Consistency with NERC Definitions of VRFs: Failure to implement and follow its PSMP could, under emergency, abnormal, or restorative conditions anticipated by the preparations, directly cause or contribute to bulk electric system instability, separation, or a cascading sequence of failures, or could place the bulk electric system at an unacceptable risk of instability, separation, or cascading failures, or could hinder restoration to a normal condition. Thus, this requirement meets the criteria for a High VRF.
FERC VRF G5 Discussion	Guideline 5- Treatment of Requirements that Co-mingle More than One Obligation: This requirement establishes a single risk-level, and the assigned VRF is consistent with that risk level.

Proposed VSL – PRC-005-6, R3			
Lower	Moderate	High	Severe
For Components included within a time-based maintenance program, the entity failed to maintain 5% or less of the total Components included within a specific Component Type, in accordance with the minimum maintenance activities and maximum maintenance intervals prescribed within Tables 1-1 through 1-5, Table 2, Table 3, Table 4-1 through 4-3, and Table 5.	For Components included within a time-based maintenance program, the entity failed to maintain more than 5% but 10% or less of the total Components included within a specific Component Type, in accordance with the minimum maintenance activities and maximum maintenance intervals prescribed within Tables 1-1 through 1-5, Table 2, Table 3, Table 4-1 through 4-3, and Table 5.	For Components included within a time-based maintenance program, the entity failed to maintain more than 10% but 15% or less of the total Components included within a specific Component Type, in accordance with the minimum maintenance activities and maximum maintenance intervals prescribed within Tables 1-1 through 1-5, Table 2, Table 3, Table 4-1 through 4-3, and Table 5.	For Components included within a time-based maintenance program, the entity failed to maintain more than 15% of the total Components included within a specific Component Type, in accordance with the minimum maintenance activities and maximum maintenance intervals prescribed within Tables 1-1 through 1-5, Table 2, Table 3, Table 4-1 through 4-3, and Table 5.

VRF and VSL Justifications – PRC-005-6, R3	
NERC VSL Guidelines	Meets NERC’s VSL Guidelines—There is an incremental aspect that the violation and the VSLs follow the guidelines for incremental violations.
FERC VSL G1 VSL Assignments Should Not Have the Unintended Consequence of Lowering the Current Level of Compliance	This VSL is consistent with the current VSLs associated with the existing requirements of the standards being replaced by this proposed standard.
FERC VSL G2 VSL Assignments Should Ensure Uniformity and Consistency in the Determination of Penalties Guideline 2a: The Single VSL Assignment Category for "Binary" Requirements Is Not Consistent Guideline 2b: VSL Assignments that Contain Ambiguous Language	Guideline 2a: N/A Guideline 2b: The proposed VSL does not use any ambiguous terminology, thereby supporting uniformity and consistency in the determination of similar penalties for similar violations.

VRF and VSL Justifications – PRC-005-6, R3

FERC VSL G3 VSL Assignment Should Be Consistent with the Corresponding Requirement	The proposed VSL uses similar terminology to that used in the associated requirement and is, therefore, consistent with the requirement.
FERC VSL G4 VSL Assignment Should Be Based on A Single Violation, Not on A Cumulative Number of Violations	The VSL is based on a single violation and not cumulative violations.

VRF and VSL Justifications – PRC-005-6, R4	
Proposed VRF	High
NERC VRF Discussion	Failure to implement and follow its PSMP could, under emergency, abnormal, or restorative conditions anticipated by the preparations, directly cause or contribute to bulk electric system instability, separation, or a cascading sequence of failures, or could place the bulk electric system at an unacceptable risk of instability, separation, or cascading failures, or could hinder restoration to a normal condition. Thus, this requirement meets the criteria for a High VRF.
FERC VRF G1 Discussion	Guideline 1- Consistency w/ Blackout Report: N/A
FERC VRF G2 Discussion	Guideline 2- Consistency within a Reliability Standard: The requirement has no subpart(s); therefore, only one VRF was assigned and no conflict(s) exist.
FERC VRF G3 Discussion	Guideline 3- Consistency among Reliability Standards: The only Reliability Standards with similar goals are those being replaced by this standard, and the High VRF assignment for this requirement is consistent with the assigned VRFs for companion requirements in those existing standards.
FERC VRF G4 Discussion	Guideline 4- Consistency with NERC Definitions of VRFs: Failure to implement and follow its PSMP could, under emergency, abnormal, or restorative conditions anticipated by the preparations, directly cause or contribute to bulk electric system instability, separation, or a cascading sequence of failures, or could place the bulk electric system at an unacceptable risk of instability, separation, or cascading failures, or could hinder restoration to a normal condition. Thus, this requirement meets the criteria for a High VRF.
FERC VRF G5 Discussion	Guideline 5- Treatment of Requirements that Co-mingle More than One Obligation: This requirement establishes a single risk-level, and the assigned VRF is consistent with that risk level.

Proposed VSL – PRC-005-6, R4			
Lower	Moderate	High	Severe
For Components included within a performance-based maintenance program, the entity failed to maintain 5% or less of the annual scheduled maintenance for a specific Component Type in accordance with their performance-based PSMP.	For Components included within a performance-based maintenance program, the entity failed to maintain more than 5% but 10% or less of the annual scheduled maintenance for a specific Component Type in accordance with their performance-based PSMP.	For Components included within a performance-based maintenance program, the entity failed to maintain more than 10% but 15% or less of the annual scheduled maintenance for a specific Component Type in accordance with their performance-based PSMP.	For Components included within a performance-based maintenance program, the entity failed to maintain more than 15% of the annual scheduled maintenance for a specific Component Type in accordance with their performance-based PSMP.

VRF and VSL Justifications – PRC-005-6, R4	
NERC VSL Guidelines	Meets NERC’s VSL Guidelines—There is an incremental aspect that the violation and the VSLs follow the guidelines for incremental violations.
FERC VSL G1 VSL Assignments Should Not Have the Unintended Consequence of Lowering the Current Level of Compliance	This VSL is consistent with the current VSLs associated with the existing requirements of the standards being replaced by this proposed standard.
FERC VSL G2 VSL Assignments Should Ensure Uniformity and Consistency in the Determination of Penalties Guideline 2a: The Single VSL Assignment Category for "Binary" Requirements Is Not Consistent Guideline 2b: VSL Assignments that Contain Ambiguous Language	Guideline 2a: N/A Guideline 2b: The proposed VSL does not use any ambiguous terminology, thereby supporting uniformity and consistency in the determination of similar penalties for similar violations.

VRF and VSL Justifications – PRC-005-6, R4

FERC VSL G3 VSL Assignment Should Be Consistent with the Corresponding Requirement	The proposed VSL uses similar terminology to that used in the associated requirement and is, therefore, consistent with the requirement.
FERC VSL G4 VSL Assignment Should Be Based on A Single Violation, Not on A Cumulative Number of Violations	The VSL is based on a single violation and not cumulative violations.

VRF and VSL Justifications – PRC-005-6, R5	
Proposed VRF	Medium
NERC VRF Discussion	Failure to initiate resolution of an unresolved maintenance issue for a Protection System Component could directly affect the electrical state or the capability of the bulk power system. However, violation of this requirement is unlikely to lead to bulk power system instability, separation, or cascading failures. The applicable entities are always responsible for maintaining the reliability of the bulk power system regardless of the situation. This VRF emphasizes the risk to system performance that results from mal-performing Protection System Components. Failure to initiate resolution of an unresolved maintenance issue for a Protection System Component will not, by itself, lead to instability, separation, or cascading failures. Thus, the requirement meets NERC’s criteria for a Medium VRF.
FERC VRF G1 Discussion	Guideline 1- Consistency w/ Blackout Report: N/A
FERC VRF G2 Discussion	Guideline 2- Consistency within a Reliability Standard: The requirement has no subpart(s); therefore, only one VRF was assigned and no conflict(s) exist.
FERC VRF G3 Discussion	Guideline 3- Consistency among Reliability Standards: The only requirement within approved Standards, PRC-004-2a Requirements R1 and R2 contain a similar requirement and is assigned a HIGH VRF. However, these requirements contain several subparts, and the VRF must address the most egregious risk related to these subparts, and a comparison to these requirements may be irrelevant. PRC-022-1 Requirement R1.5 contains only a similar requirement, and is assigned a MEDIUM VRF. FAC-003-2 Requirement R5 contains only a similar requirement, and is assigned a MEDIUM VRF.
FERC VRF G4 Discussion	Guideline 4- Consistency with NERC Definitions of VRFs: Failure to initiate resolution of an unresolved maintenance issue for a Protection System Component could directly affect the electrical state or the capability of the bulk power system.

VRF and VSL Justifications – PRC-005-6, R5			
Proposed VRF	Medium		
	<p>However, violation of this requirement is unlikely to lead to bulk power system instability, separation, or cascading failures. The applicable entities are always responsible for maintaining the reliability of the bulk power system regardless of the situation. This VRF emphasizes the risk to system performance that results from mal-performing Protection System Components. Failure to initiate resolution of an unresolved maintenance issue for a Protection System Component will not, by itself, lead to instability, separation, or cascading failures. Thus, the requirement meets NERC’s criteria for a Medium VRF.</p>		
FERC VRF G5 Discussion	<p>Guideline 5- Treatment of Requirements that Co-mingle More than One Obligation: This requirement establishes a single risk-level, and the assigned VRF is consistent with that risk level.</p>		
Proposed VSL – PRC-005-6, R5			
Lower	Moderate	High	Severe
The entity failed to undertake efforts to correct 5 or fewer identified Unresolved Maintenance Issues.	The entity failed to undertake efforts to correct greater than 5, but less than or equal to 10 identified Unresolved Maintenance Issues.	The entity failed to undertake efforts to correct greater than 10, but less than or equal to 15 identified Unresolved Maintenance Issues.	The entity failed to undertake efforts to correct greater than 15 identified Unresolved Maintenance Issues.

VRF and VSL Justifications – PRC-005-6, R5	
NERC VSL Guidelines	Meets NERC’s VSL Guidelines—There is an incremental aspect that the violation and the VSLs follow the guidelines for incremental violations.
FERC VSL G1 VSL Assignments Should Not Have the Unintended Consequence of Lowering the Current Level of Compliance	The Requirement in PRC-005-6 is identical to that in PRC-005-3, which has identical VSLs.
FERC VSL G2 VSL Assignments Should Ensure Uniformity and Consistency in the Determination of Penalties Guideline 2a: The Single VSL Assignment Category for "Binary" Requirements Is Not Consistent Guideline 2b: VSL Assignments that Contain Ambiguous Language	Guideline 2a: N/A Guideline 2b: The proposed VSL does not use any ambiguous terminology, thereby supporting uniformity and consistency in the determination of similar penalties for similar violations.

VRF and VSL Justifications – PRC-005-6, R5

FERC VSL G3 VSL Assignment Should Be Consistent with the Corresponding Requirement	The proposed VSL uses similar terminology to that used in the associated requirement and is, therefore, consistent with the requirement.
FERC VSL G4 VSL Assignment Should Be Based on A Single Violation, Not on A Cumulative Number of Violations	The VSL is based on a single violation and not cumulative violations.

Exhibit H
SAMS/SPCS Report

NERC

NORTH AMERICAN ELECTRIC
RELIABILITY CORPORATION

Considerations for Maintenance and Testing of Autoreclosing Schemes

System Analysis and Modeling Subcommittee
System Protection and Control Subcommittee

November 2012

RELIABILITY | ACCOUNTABILITY



3353 Peachtree Road NE
Suite 600, North Tower
Atlanta, GA 30326
404-446-2560 | www.nerc.com

NERC's Mission

The North American Electric Reliability Corporation (NERC) is an international regulatory authority established to enhance the reliability of the bulk power system in North America. NERC develops and enforces Reliability Standards; assesses adequacy annually via a ten-year forecast and winter and summer forecasts; monitors the bulk power system; and educates, trains, and certifies industry personnel. NERC is the electric reliability organization for North America, subject to oversight by the U.S. Federal Energy Regulatory Commission (FERC) and governmental authorities in Canada.¹

NERC assesses and reports on the reliability and adequacy of the North American bulk power system, which is divided into eight Regional areas, as shown on the map and table below. The users, owners, and operators of the bulk power system within these areas account for virtually all the electricity supplied in the U.S., Canada, and a portion of Baja California Norte, México.



Note: The highlighted area between SPP RE and SERC denotes overlapping Regional area boundaries. For example, some load serving entities participate in one Region and their associated transmission owner/operators in another.

NERC Regional Entities

FRCC Florida Reliability Coordinating Council	SERC SERC Reliability Corporation
MRO Midwest Reliability Organization	SPP RE Southwest Power Pool Regional Entity
NPCC Northeast Power Coordinating Council	TRE Texas Reliability Entity
RFC ReliabilityFirst Corporation	WECC Western Electricity Coordinating Council

¹ As of June 18, 2007, the U.S. Federal Energy Regulatory Commission (FERC) granted NERC the legal authority to enforce Reliability Standards with all U.S. users, owners, and operators of the bulk power system, and made compliance with those standards mandatory and enforceable. In Canada, NERC presently has memorandums of understanding in place with provincial authorities in Ontario, New Brunswick, Nova Scotia, Québec, and Saskatchewan, and with the Canadian National Energy Board. NERC standards are mandatory and enforceable in Ontario and New Brunswick as a matter of provincial law. NERC has an agreement with Manitoba Hydro making reliability standards mandatory for that entity, and Manitoba has recently adopted legislation setting out a framework for standards to become mandatory for users, owners, and operators in the province. In addition, NERC has been designated as the “electric reliability organization” under Alberta’s Transportation Regulation, and certain reliability standards have been approved in that jurisdiction; others are pending. NERC and NPCC have been recognized as standards-setting bodies by the Régie de l’énergie of Québec, and Québec has the framework in place for reliability standards to become mandatory. NERC’s reliability standards are also mandatory in Nova Scotia and British Columbia. NERC is working with the other governmental authorities in Canada to achieve equivalent recognition.

Table of Contents

NERC’s Mission.....	i
Table of Contents.....	iii
Introduction	1
Considerations for Applicability of PRC-005	2
Applications to Improve Bulk Power System Performance.....	2
Applications to Aid Restoration	3
Maintenance Intervals and Activities	8
Autoreclosing Relays.....	8
Autoreclosing Control Circuitry	8
Recommendations	10
Appendix A – System Analysis and Modeling Subcommittee Roster.....	11
Appendix B – System Protection and Control Subcommittee Roster	12

This technical document was approved by the NERC Planning Committee on November 14, 2012.

Introduction

On February 3, 2012, the Federal Energy Regulatory Commission (FERC) issued Order No. 758² approving an interpretation of NERC Reliability Standard PRC-005-1, Transmission and Generation Protection System Maintenance and Testing. In addition to approving the interpretation, the Commission directed that concerns identified in the preceding Notice of Proposed Rulemaking (NOPR) be addressed within the reinitiated PRC-005 revisions.

The concerns raised in the NOPR pertain to automatic reclosing (autoreclosing) relays that are either “used in coordination with a Protection System to achieve or meet system performance requirements established in other Commission-approved Reliability Standards, or can exacerbate fault conditions when not properly maintained and coordinated,” in which case “excluding the maintenance and testing of these reclosing relays will result in a gap in the maintenance and testing of relays affecting the reliability of the Bulk-Power System.”³ To address these concerns, the Commission concludes that “specific requirements or selection criteria should be used to identify reclosing relays that affect the reliability of the Bulk-Power System.”⁴

This report provides technical input from the NERC System Analysis and Modeling Subcommittee (SAMS) and the System Protection and Control Subcommittee (SPCS), both subcommittees of the NERC Planning Committee, to support the Project 2007-17 standard drafting team assigned to modify PRC-005. This report recommends technical bases to identify those autoreclosing applications that may affect reliability of the bulk power system. Such applications should be included in the Applicability section of PRC-005 to address the directives in Order No. 758.

² See FERC Order No. 758, [Interpretation of Protection System Reliability Standard](#), 138 FERC ¶ 61,094.

³ *Id.* at P. 16.

⁴ *Id.* at P. 26.

Considerations for Applicability of PRC-005

Autoreclosing is utilized on transmission systems to restore transmission elements to service following automatic circuit breaker tripping. When an autoreclosing application may affect reliability of the bulk power system, the autoreclosing relay⁵ should be included in the applicability of PRC-005.

The concerns identified by the Commission in Order No. 758 can be grouped into two categories:

- situations in which autoreclosing fails to operate when required to maintain bulk power system reliability; and
- situations in which autoreclosing operates in manner that is not consistent with its design, adversely affecting reliability of the bulk power system.

The following sections address these two categories of concern.

Applications to Improve Bulk Power System Performance

Consideration of Autoreclosing to Increase Operating Limits

Planning and operation of the bulk power system must consider autoreclosing applications.⁶ Autoreclosing following automatic circuit breaker tripping may be successful if the condition that initiated the tripping (e.g., a fault) is no longer present, or it may be unsuccessful if the condition is still present in which case the circuit breaker will trip again. While successful autoreclosing enhances reliability of the bulk power system, autoreclosing into a permanent fault may adversely affect reliability. Since the potential for autoreclosing into a permanent fault exists for any application, it is not possible to depend on successful autoreclosing as a means to meet the system performance requirements in the NERC Reliability Standards or to increase the transfer limit associated with an Interconnection Reliability Operating Limit⁷ (IROL).

Single-pole tripping and autoreclosing also may be used to minimize the impact to the system for a single-phase fault; however, the same issues exist for single-pole autoreclosing with regard to the potential for an autoreclose into a permanent fault after which all three poles are tripped. In the event an autoreclosing relay fails to initiate reclosing after a single-pole trip, protective functions will detect the condition and trip all three poles after a time delay.

SAMS and SPCS have not identified an application in which autoreclosing is used in coordination with a protection system to meet the system performance requirements in a NERC Reliability

⁵ Autoreclosing relays in this context include dedicated autoreclosing relays and the autoreclosing function in multi-function relays.

⁶ For example, TPL-001-2, adopted by the NERC Board of Trustees on August 4, 2011, requires that analyses include the impact of subsequent successful high-speed autoreclosing and unsuccessful high-speed autoreclosing into a fault where high-speed autoreclosing is utilized.

⁷ Capitalized as referenced in the NERC Glossary of Terms.

Standard or in establishing an IROL. As discussed above, the need to consider autoreclosing into a permanent fault precludes dependency on autoreclosing for this purpose. SAMS and SPCS therefore recommend that no modification is necessary to the applicability of PRC-005 to address autoreclosing applications necessary for bulk power system performance.

Autoreclosing as Part of a Special Protection System

Special Protection Systems⁸ (SPS) may be applied to meet system performance requirements in the NERC Reliability Standards or to increase the transfer limit associated with an IROL. When autoreclosing is included as an integral part of such a SPS, a failure of the reclosing function may adversely impact bulk power system reliability. NERC Reliability Standard PRC-005-2⁹ includes minimum maintenance activities and maximum intervals for SPS. SAMS and SPCS recommend that PRC-005 be modified to explicitly address maintenance and testing of autoreclosing relays applied as an integral part of a SPS.

Applications to Aid Restoration

Autoreclosing typically is installed to alleviate the burden on operators of manually restoring transmission lines. Autoreclosing also provides improved availability of overhead transmission lines. The degree to which availability is improved depends on the nature of the fault (permanent or temporary) and on transmission operator practices for manually restoring lines. While faster restoration of transmission lines following temporary faults does provide an inherent reliability benefit, this section addresses applications that are not necessary to meet system performance requirements in NERC Reliability Standards. In these applications it is possible for undesired operation of the autoreclosing scheme, not consistent with its design, to adversely affect system reliability. The following sections discuss credible failure modes that may lead to undesired operation and the associated potential reliability impacts to the bulk power system, to identify applications that should be included in the Applicability section of PRC-005.

Credible Failure Modes of Autoreclosing Schemes

This section discusses credible failure modes of autoreclosing schemes. These failure modes are assessed in the next section to identify which may impact reliability of the bulk power system. Applications for which one or more of these failure modes could adversely affect reliability will be provided to the Project 2007-17 standard drafting team to support development of revisions to PRC-005 directed in Order No. 758.

There are many different types of autoreclosing relays. Autoreclosing relays may be electromechanical (and comprised of discrete components), solid state, or microprocessor-based and may be applied in a variety of autoreclosing schemes. Regardless of the type of autoreclosing scheme or vintage of design of the autoreclosing relay, there are a few main characteristics shared by most autoreclosing relays. These include:

⁸ Capitalized as referenced in the NERC Glossary of Terms.

⁹ PRC-005-2 achieved 81.08 percent quorum and 80.51 percent approval in a recirculation ballot that ended October 24, 2012.

- **Supervision Functions:** Supervising elements typically monitor one or more voltage phases to determine if a circuit is energized (live), de-energized (dead), or in synchronism with another circuit, etc. Other types of supervision may be used to perform selective autoreclosing; e.g., autoreclosing is blocked for the detection of a three-phase fault, or for the loss of a communication channel. In some applications, autoreclosing is unsupervised.
- **Timing Functions:** Timing elements perform various timing duties with the most important being the desired time delay to issue a circuit breaker close; the minimum time delay being dictated by de-ionization time. In some applications, autoreclosing is initiated by protective relaying and issues a close signal with little or no intentional time delay.
- **Output Function:** The output function is typically some type of relay with contacts that close and apply DC voltage to the close circuit to effect a circuit breaker close.

When analyzing autoreclosing relay failure modes, the functions described above are the ones most likely to lead to a failure. The failures can be analyzed without a detailed discussion of the many variations of autoreclosing logic that may be implemented throughout North America. The main failure modes of autoreclosing relays are:

- **Supervision Function Failures:** A failed voltage supervision function that requires a dead line to reclose may incorrectly interpret that the monitored circuit is live and consequently not issue a close signal to a circuit breaker as designed. Conversely, a failed voltage supervision function that requires a live line to reclose may incorrectly interpret that a dead circuit is live and, therefore, incorrectly issue a close signal to a circuit breaker. Further, failure of a synchronism check function may allow a close when static system angles are greater than designed, or inhibit a close when static system angles are less than designed.
- **Timing Function Failures:** Where intentional time delays are used, the time delay circuits may fail and issue a close with no time delay. Failure of the time delay circuits may also inhibit the autoreclosing relay from issuing a close signal.
- **Output Function Failures:** The output relay contacts may fail to close and thus no close signal will be issued to a circuit breaker. The output relay contacts may also fail in the closed position (“weld shut”) and send a constant close signal to a circuit breaker. Solid state outputs can exhibit both of these failure modes. This failure mode can result in one of two possible scenarios depending on the circuit breaker closing circuit design and whether the constant close signal occurs prior to tripping or during the act of reclosing the circuit breaker. One scenario is that no reclose will occur. The second scenario will result in only one reclose being attempted.

Thus, to assess the potential impact of an autoreclosing relay failure on the power system, the following types of failures should be considered:

- No close signal is issued under conditions that meet the intended design conditions. This is the most common failure mode and includes the vast majority of autoreclosing failures.
- A close signal is issued with no time delay or with less time delay than is intended.
- A constant or sustained close signal is issued. In this case, a multi-shot reclose scheme may attempt to reclose only once.
- A close signal is issued for conditions other than the intended supervisory conditions.

Potential Reliability Impacts

In this section each of the identified autoreclosing failure modes is analyzed to assess the potential for adverse impact to bulk power system reliability and the circumstances under which impacts may occur.

1. No close signal is issued under conditions that meet the intended design conditions: A failure to autoreclose would result in a failure to restore a single power system element. The system already must be planned and operated considering that autoreclosing will be unsuccessful. Thus, the impact to power system reliability for this failure mode results in a condition the system is designed to withstand, and therefore this failure mode does not create any additional considerations for inclusion of autoreclosing relays in PRC-005 beyond those related to SPS as discussed in the previous section.
2. A close signal is issued with no time delay or with less time delay than is intended: This failure mode can result in a minimum trip-close-trip sequence with the two faults cleared in primary protection operating time, and the open time between faults equal to the breaker closing cycle time. The sequence for this failure mode results in system impact equivalent to a high-speed autoreclosing sequence with no delay added in the autoreclosing logic.

The potential reliability impacts of this failure mode are damage to generators and generator instability. Autoreclosing logic typically is selected to reenergize a dead circuit remote from generating units or strong sources to avoid adverse impacts associated with autoreclosing into a permanent fault. Typically when autoreclosing is applied at a generating station it is only for live-line conditions with synchronism check; however, applications do exist where autoreclosing from a generating station is used such as transmission lines between two generating plants, or radial lines that cannot be energized from another source. Where autoreclosing is applied at or in proximity to a generating station the potential for this failure mode exists.

Premature autoreclosing has the potential to cause generating unit loss of life due to shaft fatigue. Accepted industry guidance is that planned switching operations, such as simple line restoration, should be conducted in a way that avoids significant contribution to cumulative shaft fatigue. Entities typically implement this guidance at generating stations by using time delayed autoreclosing to allow shaft oscillations to dampen, and/or live line autoreclosing or live bus-live line autoreclosing with synchronism check supervision to

minimize shaft torque. By conducting planned switching in this manner, nearly all of the fatigue capability of the shaft is preserved to withstand the impact of unplanned and unavoidable disturbances such as faults, fault clearing, reclosing into system faults, and emergency line switching. Premature autoreclosing due to a supervision failure is a small subset of autoreclosing failures (the overwhelming majority of autoreclosing failures are failure to close) and is an infrequent unplanned disturbance. As a result, it is not necessary to consider the incremental loss of life that may occur for this infrequent event as the basis for whether to include maintenance and testing of autoreclosing relays in PRC-005.

Premature autoreclosing also has the potential to cause generating unit or plant instability. NERC Reliability Standards require consideration of loss of the largest generating unit within a Balancing Authority Area¹⁰; therefore, generation loss would not impact reliability of the bulk power system unless the combined capacity loss exceeds the largest unit within the Balancing Authority Area. Including maintenance and testing of autoreclosing relays in PRC-005 would therefore be appropriate for applications at or in proximity to generating plants with capacity exceeding the largest unit within the Balancing Authority Area. In this context proximity is defined as one bus away if the bus is within 10 miles of the generating plant. Transmission line impedance on the order of 1 mile away typically provides adequate impedance to prevent generating unit instability and a 10 mile threshold provides sufficient margin.

At these locations, maintenance and testing of autoreclosing relays should be subject to PRC-005, unless the equipment owner can demonstrate to the Transmission Planner that this failure mode would not result in tripping generating units with combined capacity greater than the largest unit within the Balancing Authority Area. This demonstration should be based on simulation of a close-in three-phase fault for twice the normal clearing time (capturing a minimum trip-close-trip time delay).

3. A constant or sustained close signal is issued: This failure mode can result in one of two possible scenarios depending on the circuit breaker closing circuit design and whether the constant close signal occurs prior to tripping or during the act of reclosing the circuit breaker. One scenario is that no reclose will occur. The second scenario will result in only one reclose being attempted. This scenario results in the worse impact; however this results in an outcome similar to failure mode No. 1 – less reclose attempts than planned. Neither of these failure modes creates any additional considerations for inclusion of autoreclosing relays in PRC-005.
4. A close signal is issued for conditions other than the intended supervisory conditions: This failure mode can result in two different scenarios.

The first scenario is autoreclosing into a dead line with a fault when dead-line closing was not intended. Similar to failure mode No. 2 discussed above, the potential reliability

¹⁰ Capitalized as referenced in the NERC Glossary of Terms.

impacts of this failure mode are instability and damage to generating units. The incidence of this failure mode is similar to failure mode No. 2 and therefore concern may be limited to the potential loss of generating units with combined capacity that exceeds the largest unit within the Balancing Authority Area. Including maintenance and testing of autoreclosing relays in PRC-005 would therefore be appropriate for applications at or in proximity to generating units as noted above. The primary difference between this scenario and failure mode No. 2 is this failure mode does not include a timing failure. As such both this scenario and failure mode No. 2 can lead to unintended autoreclosing into fault; however, the timing of the undesired autoreclosure in this scenario will occur after any intentional time delay included in the autoreclosing relay. For this reason a separate test is not necessary to exclude applications from maintenance and testing under PRC-005. Application of the test described for failure mode No. 2 adequately addresses this failure mode.

The second scenario is autoreclosing into a live line with an angle greater than the acceptance angle necessary to prevent potential equipment damage. The potential reliability impact of this failure mode is damage to generating units. As noted in the discussion of failure mode No. 2, accepted industry guidance is that planned switching operations, such as simple line restoration, should be conducted in a way that avoids significant contribution to cumulative shaft fatigue. By conducting planned switching in this manner, nearly all of the fatigue capability of the shaft is preserved to withstand the impact of unplanned and unavoidable disturbances such as faults, fault clearing, reclosing into system faults, and emergency line switching. Undesired autoreclosing at an angle greater than the sync-check acceptance angle due to a supervision failure is a small subset of autoreclosing failures and is an infrequent unplanned disturbance. As a result, it is not necessary to consider the incremental loss of life that may occur for this infrequent event as the basis for whether to include maintenance and testing of autoreclosing relays in PRC-005.

Maintenance Intervals and Activities

The SPCS reviewed the maximum maintenance intervals and minimum maintenance activities proposed in reliability standard PRC-005-2. Specifically, the SPCS reviewed Table 1-1 which is applicable to protective relays and Table 1-5 which is applicable to control circuitry associated with protective functions (excluding distributed UFLS and distributed UVLS). The SPCS review focused on whether any substantive differences exist between protective relays and autoreclosing relays, or between control circuitry associated with protective functions and circuitry associated with autoreclosing schemes, that would warrant different intervals or activities for maintenance of autoreclosing components.

Autoreclosing Relays

The SPCS concluded that electromechanical, solid-state, and microprocessor based autoreclosing relays are substantially the same with respect to design and manufacturing as their protective relay counterparts. As such, the SPCS recommends that the maximum intervals defined in Table 1-1 of PRC-005-2 should also be applicable to autoreclosing relays that may be subject to future versions of the standard.

The SPCS also assessed the maintenance activities included in Table 1-1 of PRC-005-2 and concluded that the activities are analogous to activities performed during maintenance and testing of autoreclosing relays and therefore Table 1-1 should be applied to autoreclosing relays that may be subject to future versions of the standard. For example, the activity to test and, if necessary calibrate, non-microprocessor relays would be applicable to testing and calibration of electromechanical and solid-state autoreclosing relays, and the activity to verify acceptable measurement of power system input values would be applicable to verification of permissive inputs used for voltage supervision and synchronism check.

Autoreclosing Control Circuitry

Similarly, the SPCS assessed the maintenance intervals and activities included in Table 1-5 of PRC-005-2 and concluded that the intervals and activities for maintaining control circuitry for autoreclosing schemes should be similar to those established for maintaining control circuitry associated with protective functions. The SPCS recommends that Table 1-5 should be applicable to control circuitry associated with autoreclosing relays that may be subject to future versions of the standard. The SPCS also recommends that the standard drafting team include minimum maintenance activities and maximum maintenance intervals for autoreclosing control circuitry that parallel the maintenance activities and intervals established for protective function control circuitry. It should be noted that, consistent with control circuitry defined for protective functions, the SPCS does not consider internal breaker control circuitry (e.g., anti-pump and coil interlock circuits) to be associated with autoreclosing component maintenance. Since the failure to close may represent a risk to reliability when breaker closing is integral to operation of an SPS, the closing coil should be considered in PRC-005. For use within a revision to PRC-005, control circuitry of autoreclosing schemes might be defined as:

“Control circuitry associated with autoreclosing schemes including the close coil, but excluding breaker internal controls such as anti-pump and various interlock circuits.”

Recommendations

SAMS and SPCS recommend the following guidance for future development of NERC Reliability Standard PRC-005, *Transmission and Generation Protection System Maintenance and Testing*, to address the concerns stated in FERC Order No. 758.

1. Modify PRC-005 to explicitly address maintenance and testing of autoreclosing relays applied as an integral part of a SPS.
2. Modify PRC-005 to include maintenance and testing of autoreclosing relays at or in proximity to generating plants at which the total installed capacity is greater than the capacity of the largest generating unit within the Balancing Authority Area.
 - In this context, define proximity as substations one bus away if the substation is within 10 miles of the plant.
 - Include a provision to exclude autoreclosing relays if the equipment owner can demonstrate to the Transmission Planner that a close-in three-phase fault for twice the normal clearing time (capturing a minimum trip-close-trip time delay) does not result in a total loss of generation in the interconnection exceeding the largest unit within the Balancing Authority Area where the autoreclosing is applied.
3. Base minimum maintenance activities and maximum intervals on the activities and intervals in PRC-005-2.
 - Develop minimum maintenance activities and maximum intervals for autoreclosing relays similar to Table 1-1.
 - Develop minimum maintenance activities and maximum intervals for control circuitry of autoreclosing schemes similar to Table 1-5.
 - For the purpose of PRC-005, define control circuitry of autoreclosing schemes as: “Control circuitry associated with autoreclosing schemes including the close coil, but excluding breaker internal controls such as anti-pump and various interlock circuits.”

Appendix A – System Analysis and Modeling Subcommittee Roster

John Simonelli

Chair

Director - Operations Support Services
ISO New England

K. R. Chakravarthi

Vice Chair

Manager, Interconnection and Special Studies
Southern Company Services, Inc.

G. Brantley Tillis, P.E.

RE – FRCC

Manager, Transmission Planning Florida
Progress Energy Florida

Kiko Barredo

RE – FRCC – Alternate

Manager, Bulk Transmission Planning
Florida Power & Light Co.

Thomas C. Mielnik

RE – MRO

Manager Electric System Planning
MidAmerican Energy Co.

Salva R. Andiappan

RE – MRO – Alternate

Manager - Modeling and Reliability Assessments
Midwest Reliability Organization

Donal Kidney

RE – NPCC

Manager, System Compliance Program Implementation
Northeast Power Coordinating Council

Bill Harm

RE – RFC

Senior Consultant
PJM Interconnection, L.L.C.

Mark Byrd

RE – SERC

Manager - Transmission Planning
Progress Energy Carolinas

Gary T. Brownfield

RE – SERC – Alternate

Supervising Engineer, Transmission Planning
Ameren Services

Jonathan E. Hayes

RE – SPP

Reliability Standards Development Engineer
Southwest Power Pool, Inc.

Kenneth A. Donohoo

RE – TRE

Director System Planning
Oncor Electric Delivery

Hari Singh

RE – WECC

Transmission Asset Management
Xcel Energy, Inc.

Kent Bolton

RE – WECC – Alternate

Staff Engineer
Western Electricity Coordinating Council

Digaunto Chatterjee

ISO/RTO

Manager of Transmission Expansion Planning
Midwest ISO, Inc.

Patricia E. Metro

Cooperative

Manager, Transmission and Reliability Standards
National Rural Electric Cooperative Association

Eric Mortenson, P.E.

Investor-Owned Utility

Principal Rates & Regulatory Specialist
Exelon Business Services Company

Amos Ang, P.E.

Investor-Owned Utility

Engineer, Transmission Interconnection Planning
Southern California Edison

Greg Henry

NERC Staff Coordinator

Senior Performance and Analysis Engineer
NERC

Appendix B – System Protection and Control Subcommittee Roster

William J. Miller

Chair

Principal Engineer
Exelon Corporation

Philip B. Winston

Vice Chair

Chief Engineer, Protection and Control
Southern Company

Michael Putt

RE – FRCC

Manager, Protection and Control Engineering Applications
Florida Power & Light Co.

Mark Gutzmann

RE – MRO

Manager, System Protection Engineering
Xcel Energy, Inc.

Richard Quest

RE – MRO – Alternate

Principal Systems Protection Engineer
Midwest Reliability Organization

George Wegh

RE – NPCC

Manager
Northeast Utilities

Jeff Iler

RE – RFC

Senior Engineer
American Electric Power

Joe Spencer

RE – SERC -- Alternate

Manager of Planning and Engineering
SERC Reliability Corporation

Lynn Schroeder

RE – SPP

Manager, Substation Protection and Control
Westar Energy

Samuel Francis

RE – TRE

System Protection Specialist
Oncor Electric Delivery

Baj Agrawal

RE – WECC

Principal Engineer
Arizona Public Service Company

Miroslav Kostic

Canada Provincial

P&C Planning Manager, Transmission
Hydro One Networks, Inc.

Sungsoo Kim

Canada Provincial

Section Manager – Protections and Technical Compliance
Ontario Power Generation Inc.

Michael J. McDonald

Investor-Owned Utility

Principal Engineer, System Protection
Ameren Services Company

Jonathan Sykes

Investor-Owned Utility

Manager of System Protection
Pacific Gas and Electric Company

Charles W. Rogers

Transmission Dependent Utility

Principal Engineer
Consumers Energy Co.

Joe T. Uchiyama

U.S. Federal

Senior Electrical Engineer
U.S. Bureau of Reclamation

Daniel McNeely

U.S. Federal – Alternate

Engineer - System Protection and Analysis
Tennessee Valley Authority

Philip J. Tatro

NERC Staff Coordinator

Senior Performance and Analysis Engineer
NERC

Exhibit I

Summary of Development and Complete Record of Development

Summary of Development PRC-005-5

Summary of Development History

The development record for proposed Reliability Standard PRC-005-5 is summarized below.

I. Overview of the Standard Drafting Team

When evaluating a proposed Reliability Standard, the Commission is expected to give “due weight” to the technical expertise of the ERO.¹ The technical expertise of the ERO is derived, in part, from the standard drafting team. For this project, the standard drafting team consisted of industry experts, all with a diverse set of experiences. A roster of the standard drafting team members is included in Exhibit J.

II. Standard Development History

A. Standard Authorization Request Development

A Standard Authorization Request (“SAR”) was submitted to the Standards Committee (“SC”) on October 1, 2013 and accepted by the SC October 17, 2013.

B. First Posting-Comment Period and Ballot

Proposed Reliability Standard PRC-005-5 was posted for a 45-day public comment period from December 8, 2014 through January 22, 2015, with an initial ballot conducted from January 12, 2015 through January 22, 2015.² Several documents were posted for guidance with the first draft, including the proposed Reliability Standard, the associated Implementation Plan, the Unofficial Comment Form, and the SAR. The proposed Reliability Standard received a quorum of 77.93% and an approval of 93.74%. There were 17 sets of responses, including

¹ Section 215(d) (2) of the Federal Power Act; 16 U.S.C. §824(d) (2) (2006).

² The Project 2014-01 standard drafting team posted PRC-005-X(X)/PRC-005-4(X) for a formal comment period from June 12, 2014 through July 29, 2014 with an initial ballot from July 18, 2014 through July 29, 2014. This posted version, which used an earlier draft of PRC-005-4 developed through Project 2007.17.3 than that ultimately approved by the ballot body, was intended only to address the applicability of the draft PRC-005-4 version to dispersed generation resources.

comments from approximately 64 different people from approximately 50 companies representing all 10 of the industry segments.³

C. Final Ballot

Proposed Reliability Standard PRC-005-5 was posted for a 10-day final ballot period from March 2, 2015 through March 11, 2015. The proposed Reliability Standard received a quorum of 83.52% and an approval of 98.03%.

D. Board of Trustees Approval

Proposed Reliability Standard PRC-005-5 was approved by NERC Board of Trustees on May 7, 2015.

³ NERC, *Consideration of Comments*, Project 2014-01, (November 4, 2015), available at http://www.nerc.com/pa/Stand/Prjct201401StdndsAppDispGenRes/Comment%20Report_2014-01_DGR_final.pdf.

Complete Record of Development PRC-005-5

[Program Areas & Departments > Standards > Project 2014-01 Standards Applicability for Dispersed Generation Resources](#)
Project 2014-01 Standards Applicability for Dispersed Generation Resources

Related Files

Status

A 30-day comment period for the **Project 2014-01 Standards Applicability for Dispersed Generation Resources White Paper** concluded at **8 p.m. Eastern Monday, July 13, 2015.**

This version of the White Paper is being posted for comment to allow the White Paper to proceed through the Section 11 process set forth in the NERC Standard Processes Manual, which requires NERC Standards Committee authorization to post all supporting references that are linked to an approved Reliability Standard.

Board Adopted November 13, 2014 - PRC-004-2.1(i)a, PRC-004-4, PRC-005-2(i), and PRC-005-3(i)
May 7, 2015 - PRC-005-5

Filed with FERC

Order Effective

Enforcement Date

Background:

The Standards Authorization Request (SAR) asks that the applicability section of certain Reliability Standards that apply to a Generator Owner (GO)/Generator Operator (GOP) or the requirements of certain GO/GOP Reliability Standards be reviewed, and where appropriate revised to recognize the unique technical and reliability aspects of dispersed generation in order to ensure the applicability of the standards is consistent with the reliable operation of the Bulk Electric System (BES). Dispersed generation resources are those resources that are small-scale power generation technologies using a system designed primarily for aggregating capacity providing an alternative to, or an enhancement of, the traditional electric power system. Examples could include but are not limited to solar, geothermal, energy storage, flywheels, wind, micro-turbines, and fuel cells.

This request is related to the revised definition of the Bulk Electric System (BES) from Project 2010-17, and it is desirable to complete any revisions determined to be necessary so that revisions are approved by the Board of Trustees and applicable regulatory agencies prior to the effective date for newly identified elements under the revised BES definition. This effective date is expected to be July 1 2016, although it is possible that regulatory action could change the date.

Draft	Actions	Dates	Results	Consideration of Comments
<p>White Paper Clean Redlined to Last Posted</p> <p>Supporting Materials Unofficial Comment Form (Word)</p> <p>* Appendix A – List of all NERC standards applicable to GOs/GOPs</p> <p>* Appendix B – NERC standards recommended for consideration to clarify applicability for dispersed generation</p>	<p>Comment Period</p> <p>Info</p> <p>Submit Comments</p>	<p>06/12/15 - 07/13/15</p>	<p>Comments Received</p>	
<p>*Appendix A and Appendix B are reflected in separate tabs in a single Excel document, which is duplicated and posted for reference under individual links, one for Appendix A, and one for Appendix B.</p>				

Errata Change:

On November 13, 2014, the NERC Board of Trustees (Board) adopted PRC-006-2, PRC 004-2.1(i)a, PRC-004-4, PRC-005-2(i), and PRC-005-3(i). Each of these standards, or its associated documents, contain inadvertent errors that needed to be corrected prior to filing with applicable regulatory authorities. The standards referenced the implementation plan in the Effective Date section. As a result, there are no associated changes to the standard with the corrections.

Each error and how the corrections meet the required elements of an errata change are described below.

References to “(X)” in Implementation Plans for PRC-004-2(i)a, PRC-005-2(i), and PRC-005-3(i) needed to be changed to align the standard versions with the updated NERC standards numbering convention.

The Effective Date language in the Implementation Plan for PRC-004-4 needed to be corrected to properly sequence version 4 to become effective concurrently with or after version 3. The implementation plan provided for an immediate effective date, which in some scenarios could make version 4 effective prior to version 3, which has a 12 month period after approval before it becomes effective. The drafting team intended to sequence the standards to ensure that version 4 did not go into effect prior to version 3, but went into effect immediately upon approval if version 3 was effective.

A correction was also needed to ensure version 4 becomes effective on the later of the effective date of PRC-004-3 or the date that PRC-004-4 is approved by an applicable governmental authority. A conforming correction to reference the effective date of PRC-004-3 rather than “12 months following the approval of PRC-004-3” to make sure that the implementation timing for PRC-004-3 is properly cross referenced was also needed.

Implementation Plans

PRC-005-2(i)

[Clean](#) | [Redline to Last Approved](#)

PRC-005-3(i)

[Clean](#) | [Redline to Last Approved](#)

PRC-004-2.1(i)

[Clean](#) | [Redline to Last Approved](#)

PRC-004-4

[Clean](#) | [Redline to Last Approved](#)

Project 2014-01 did not conduct non-binding polls for VRF/VSLs because the project was limited to applicability changes to the requirements that neither impacted, nor necessitated revision to, any of the VRFs and VSLs associated with the project.

<p>Final Draft</p> <p>PRC-005-5 Clean (33) Redline to Last Posted (34) Redline to PRC-005-4 (35)</p> <p>Implementation Plan Clean (36) Redline to Last Posted (37)</p> <p>Supporting Documents</p> <p>SAR (38)</p>	<p>Final Ballot</p> <p>Info>> (39)</p> <p>Vote>></p>	<p>03/02/15 – 03/11/15</p>	<p>Summary>> (40)</p> <p>Ballot Results>> (41)</p>	
--	--	----------------------------	--	--

<p>Final Drafts</p> <p>PRC-001-1.1(ii) Clean Redline to Last Posted Redline to PRC-001-1.1</p> <p>PRC-019-2 Clean Redline to Last Posted Redline to PRC-019-1</p> <p>PRC-024-2 Clean Redline to Last Posted Redline to PRC-024-1</p> <p>Implementation Plans</p> <p>PRC-001-1.1(ii) Clean Redline to Last Posted</p> <p>PRC-019-2 Clean Redline to Last Posted</p> <p>PRC-024-2 Clean Redline to Last Posted</p> <p>SAR</p>	<p>Final Ballots</p> <p>Info>></p> <p>Vote>></p> <p>(Closed)</p>	<p>01/13/15 - 01/22/15</p>	<p>Summary>></p> <p>Ballot Results</p> <p>PRC-001-1.1(ii)>></p> <p>PRC-019-2>></p> <p>PRC-024-2>></p>	
---	--	----------------------------	---	--

<p>White Paper Clean (26) Redline to Last Posted (27)</p> <p>Appendix A (28) – List of all NERC standards applicable to GOs/GOPs</p> <p>Appendix B – (29) NERC standards recommended for consideration to clarify applicability for dispersed generation</p> <p>Unofficial Comment Form(Word) (30)</p>	<p>Comment Period</p> <p>Info>> (31)</p> <p>Submit Comments>></p> <p>(Closed)</p>	<p>12/22/14 - 01/20/15</p>	<p>Comments Received>> (32)</p>	
<p>Draft 1</p> <p>PRC-005-5 Clean (14) Redline to Last Posted (15)</p>	<p>Initial Ballot</p> <p>Info>> (19)</p> <p>Vote>></p> <p>(Closed)</p>	<p>1/12/15 – 1/22/15</p>	<p>Summary>> (22)</p> <p>Ballot Results>> (23)</p>	<p>Consideration of Comments>> (25)</p>
<p>Implementation Plan (16)</p> <p>Supporting Documents</p> <p>Unofficial Comment Form (Word) (17)</p> <p>SAR (18)</p>	<p>Comment Period</p> <p>Info>> (20)</p> <p>Submit Comments>></p> <p>(Closed)</p>	<p>12/8/14 – 1/22/15</p>	<p>Comments Received>> (24)</p>	
		<p>12/8/14 – 1/8/15</p>		

	<p>Join Ballot Pool</p> <p>Info>> (21)</p> <p>Join>></p> <p>(Closed)</p>				
<p>Draft 1 Standards</p> <p>PRC-001-1.1(X) Clean Redline to PRC-001-1.1</p> <p>PRC-019-2 Clean Redline to PRC-019-1</p> <p>PRC-024-1(X) Clean Redline to last posted PRC-024-1</p> <p>Implementation Plans PRC-001-1.1(X)</p> <p>PRC-019-2</p> <p>PRC-024-1(X)</p> <p>Supporting Documents Unofficial Comment Form (Word)</p> <p>SAR</p>	<p>Initial Ballots</p> <p>Updated Info>></p> <p>Info>></p> <p>Vote>></p> <p>(Closed)</p>	12/10/14 – 12/23/14	<p>Summary>></p> <p>Ballot Results</p> <p>PRC-001-1.1(X)</p> <p>PRC-019-2</p> <p>PRC-024-1(X)</p>	<p>Consideration of Comments>> Clean Redline</p>	
	<p>Comment Period</p> <p>Info>></p> <p>Submit Comments>></p> <p>(Closed)</p>	11/5/14 – 12/23/14	<p>Comments Received>></p>		
	<p>The ballots and comment period have been extended one additional day to 8 p.m. Eastern on Tuesday, December 23, 2014 in order to reach quorum</p>				
	<p>Join Ballot Pools</p> <p>Info>></p> <p>Join>></p> <p>(Closed)</p>	11/5/14 – 12/4/14			
<p>The comment period and initial ballot close dates have been extended one day to December 22, 2014 (for the medium-priority Reliability</p>					

	Standards) due to a NERC.com maintenance outage that occurred on Saturday, December 13, 2014.			
<p>Final Drafts</p> <p>PRC-004-2.1(i)a Clean Redline to last posted</p> <p>Redline to PRC-004-2.1a</p> <p>PRC-004-4 Clean Redline to last posted</p> <p>Redline to PRC-004-3</p> <p>VAR-002-4 Clean Redline to last posted</p> <p>Redline to VAR-002-3</p> <p>Implementation Plans</p> <p>PRC-004-2.1(i)a Clean (No changes to last posted)</p> <p>PRC-004-4</p>	<p>Final Ballots</p> <p>Info>></p> <p>Vote>></p> <p>(Closed)</p>	<p>10/28/14 – 11/06/14</p>	<p>Summary>></p> <p>Ballot Results</p> <p>PRC-004-2.1(i)a>></p> <p>PRC-004-4>></p> <p>VAR-002-4>></p>	

<p>Clean (No changes to last posted)</p> <p>VAR-002-4 Clean (No changes to last posted)</p> <p>SAR</p>				
<p>Draft 2 Standard</p> <p>PRC-004-2.1a(X) Clean Redline to PRC-004-2.1a Redline to last posted</p> <p>PRC-004-4 Clean Redline to PRC-004-3 Redline to last posted</p> <p>Implementation Plans PRC-004-2.1a(X) Clean Redline to last posted</p> <p>PRC-004-4 Clean Redline to last posted</p> <p>Supporting Documents Unofficial Comment Form (Word)</p>	<p>Additional Ballots</p> <p>Updated Info>></p> <p>Info>></p> <p>Vote>></p> <p>(Closed)</p>	<p>10/10/14 - 10/22/14</p>	<p>Summary>></p> <p>Ballot Results</p> <p>PRC-004-2.1a(X)>></p> <p>PRC-004-4>></p>	<p>Consideration of Comments</p> <p>PRC-004>></p> <p>VAR-002-4>></p>
	<p>Comment Period Info>></p> <p>Submit Comments>></p> <p>(Closed)</p>	<p>9/5/14 - 10/22/14</p>	<p>Comments Received>></p>	

<p>Coordination Plan and Explanation of Version Numbers</p> <p>SAR</p>				
<p>Draft 2</p> <p>PRC-005-2(X) Clean Redline to last posted Redline to PRC-005-2</p> <p>PRC-005-3(X) Clean Redline to last posted Redline to PRC-005-3</p> <p>Implementation Plans PRC-005-2(X) PRC-005-3(X)</p> <p>Supporting Documents</p> <p>Coordination Plan and Explanation of Version Numbers</p> <p>SAR</p>	<p>Final Ballots</p> <p>Info>></p> <p>Vote>></p> <p>(Closed)</p>	<p>8/27/14 – 9/5/14</p>	<p>Summary>></p> <p>Ballot Results</p> <p>PRC-005-2(X)>></p> <p>PRC-005-3(X)>></p>	
<p>Draft 2</p> <p>VAR-002-2b(X)</p>	<p>Additional Ballots</p> <p>Updated Info>></p> <p>Info>></p>	<p>10/7/14 – 10/16/14</p>	<p>Summary>></p>	

<p>Clean Redline to Last Posted Redline to VAR-002-2b</p> <p>VAR-002-4 Clean Redline to last posted Redline to VAR-002-3</p> <p>Implementation Plan VAR-002-2b(X) VAR-002-4</p> <p>Supporting Documents Unofficial Comment Form (Word) Coordination Plan and Explanation of Version Numbers SAR</p>	<p>Vote>> (Closed)</p>		<p>Ballot Results VAR-002-4>> VAR-002-2b(X)>></p>	
	<p>Comment Period Info>> Submit Comments>> (Closed)</p>	<p>8/27/14 – 10/16/14</p>	<p>Comments Received>></p>	
<p>Draft 1 Standard PRC-004-2.1a(X) Clean Redline to PRC-004-2.1a PRC-004-3(X) Clean Redline to PRC-004-3</p>	<p>Initial Ballots Updated Info>> Info>> Vote>> (Closed)</p>	<p>8/15/14 – 8/26/14</p>	<p>Summary>> Ballot Results PRC-004-2.1a(X)>> PRC-004-3(X)>></p>	
<p>Implementation Plans</p>	<p>Comment Period</p>	<p>7/10/14 – 8/26/14</p>	<p>Comments Received>></p>	<p>Consideration of Comments>></p>

<p>PRC-004-2.1a(X)</p> <p>PRC-004-3(X)</p> <p>Supporting Documents</p> <p>Unofficial Comment Form (Word)</p> <p>Coordination Plan and Explanation of Version Numbers</p> <p>SAR</p> <p>Draft Reliability Standard Audit Worksheets (RSAW)</p> <p>PRC-004-2.1a</p> <p>PRC-004-3</p> <p>PRC-005-1.1b</p>	<p>Info>></p> <p>Submit Comments>></p> <p>(Closed)</p> <p>Join Ballot Pools>></p> <p>(Closed)</p> <p>Please note: As a convenience to stakeholders, if you have previously joined the ballot pool for VAR-002-2b(X), no action is needed - you have automatically been entered into both the PRC-004-2.1a(X) and PRC-004-3(X) ballot pools. If you have been automatically entered and <u>do not</u> wish to participate, please contact Wendy Muller prior to July 16, 2014 to have your name removed.</p>	<p>7/10/14 - 7/16/14</p>		
<p>Draft 1 Standards</p> <p>PRC-005-2(X) Clean Redline to PRC-005-2</p> <p>PRC-005-3(X) Clean Redline to PRC-005-3</p> <p>PRC-005-X(X) Clean (1) Redline to last posted PRC-005-X (2)</p>	<p>Initial Ballots</p> <p>Updated Info>> (6)</p> <p>Info>> (7)</p> <p>Vote>></p> <p>(Closed)</p>	<p>7/18/14 – 7/29/14</p>	<p>Summary>> (10)</p> <p>Ballot Results:</p> <p>PRC-005-2(X)>></p> <p>PRC-005-3(X)>></p> <p>PRC-005-X(X)>> (11)</p>	

<p>VAR-002-2b(X) Clean Redline to VAR-002-2b</p>			<p>VAR-002-2b(X)>> VAR-002-4>></p>	
<p>VAR-002-4 Clean Redline to VAR-002-3</p> <p>Implementation Plans</p> <p>PRC-005-2(X) PRC-005-3(X)</p>	<p>Formal Comment Period</p> <p>Info>> (8)</p> <p>Submit Comments>></p> <p>(Closed)</p>	<p>6/12/14 – 7/29/14</p>	<p>Comments Received>> (12)</p>	<p>Consideration of Comments>> (13)</p>
<p>PRC-005-X(X) (3)</p> <p>VAR-002-2b(X) VAR-002-4</p> <p>Supporting Documents</p> <p>Unofficial Comment Form (Word) (4)</p> <p>Coordination Plan and Explanation of Version Numbers (5)</p> <p>SAR</p> <p>Draft Reliability Standard Audit Worksheets (RSAW)</p> <p>VAR-002-2b</p> <p>VAR-002-3</p>	<p>Join Ballot Pool</p> <p>Info>> (9)</p> <p>Join>></p> <p>(Closed)</p> <p>Please note: these ballot pool join periods have been extended to 8 p.m. Eastern on Wednesday, July 16, 2014 in order to keep the closing dates for Project 2014-01 the same.</p>	<p>6/12/14 – 7/16/14</p>		

<p>White Paper</p> <p>Appendix A – List of all NERC standards applicable to GOs/GOPs</p> <p>Appendix B – NERC standards recommended for consideration to clarify applicability for dispersed generation</p> <p>Unofficial Comment Form</p>	<p>Informal Comment Period</p> <p>Info>></p> <p>Submit Comments>></p>	<p>04/17/14 - 05/05/14</p>	<p>Comments Received>></p>	<p>Consideration of Comments>></p>
<p>SAR</p> <p>Supporting Documents:</p> <p>Unofficial Comment Form (Word)</p>	<p>Comment Period</p> <p>Info>></p> <p>Submit Comments>></p>	<p>11/20/13 - 12/19/13</p> <p>(closed)</p>	<p>Comments Received>></p>	<p>Consideration of Comments>></p>

Standard PRC-005-4(X) – Protection System, Automatic Reclosing, and Sudden Pressure Relaying Maintenance

Standard Development Timeline

This section is maintained by the drafting team during the development of the standard and will be removed when the standard becomes effective.

Development Steps Completed

1. SAR posted for comment November 20 – December 19, 2013.

Description of Current Draft

The Project 2014-01, Standards Applicability for Dispersed Generation Resources Standards Drafting Team (DGR SDT) is posting proposed applicability changes to PRC-005-3 for comment and ballot. This draft contains the DGR SDT's recommended changes within the standard, which are intended to clarify application of the Requirements to Bulk Electric System (BES) dispersed power producing resources. Project 2014-01 does not have in its scope any technical content changes beyond revising the applicability to ensure consistent application of the Requirements of PRC-005 to dispersed power-producing resources.

In a parallel effort, the Protection System Maintenance and Testing Standard Drafting Team (PSMT SDT) has posted draft 1 of PRC-005-X for a 45-day comment period, and ballot in the last ten days of the comment period under the new Standards Process Manual (Effective: June 26, 2013).

Anticipated Actions	Anticipated Date
45-day Formal Comment Period with Initial Ballot	June – July 2014
45-day Additional Formal Comment Period with Additional Ballot (if necessary)	August – September 2014
Final ballot	October 2014
BOT adoption	November 2014

Definitions of Terms Used in Standard

This section includes all newly defined or revised terms used in the proposed standard. Terms already defined in the Reliability Standards Glossary of Terms (Glossary) are not repeated here. New or revised definitions listed below become approved when the proposed standard is approved. When the standard becomes effective, this defined term will be removed from the individual standard and added to the Glossary.

Protection System Maintenance Program (PSMP) — An ongoing program by which Protection System, Automatic Reclosing, and Sudden Pressure Relaying Components are kept in working order and proper operation of malfunctioning components is restored. A maintenance program for a specific Component includes one or more of the following activities:

- Verify — Determine that the Component is functioning correctly.
- Monitor — Observe the routine in-service operation of the Component.
- Test — Apply signals to a Component to observe functional performance or output behavior, or to diagnose problems.
- Inspect — Examine for signs of Component failure, reduced performance or degradation.
- Calibrate — Adjust the operating threshold or measurement accuracy of a measuring element to meet the intended performance requirement.

See Section A.6, Definitions Used in this Standard, for additional definitions that are new or modified for use within this standard.

Standard PRC-005-4(X) – Protection System, Automatic Reclosing, and Sudden Pressure Relaying Maintenance

When this standard has received ballot approval, the text boxes will be moved to the Application Guidelines Section of the Standard.

A. Introduction

- 1. Title:** Protection System, Automatic Reclosing, and Sudden Pressure Relaying Maintenance
- 2. Number:** PRC-005-X
- 3. Purpose:** To document and implement programs for the maintenance of all Protection Systems, Automatic Reclosing, and Sudden Pressure Relaying affecting the reliability of the Bulk Electric System (BES) so that they are kept in working order.
- 4. Applicability:**
 - 4.1. Functional Entities:**
 - 4.1.1** Transmission Owner
 - 4.1.2** Generator Owner
 - 4.1.3** Distribution Provider
 - 4.1.4** Balancing Authority
 - 4.2. Facilities:**
 - 4.2.1** Protection Systems and Sudden Pressure Relaying that are installed for the purpose of detecting Faults on BES Elements (lines, buses, transformers, etc.)
 - 4.2.2** Protection Systems used for underfrequency load-shedding systems installed per ERO underfrequency load-shedding requirements.
 - 4.2.3** Protection Systems used for undervoltage load-shedding systems installed to prevent system voltage collapse or voltage instability for BES reliability.
 - 4.2.4** Protection Systems installed as a Special Protection System (SPS) for BES reliability.
 - 4.2.5** Protection Systems for the following BES generator Facilities for generators not identified through Inclusion I4 of the BES definition:
 - 4.2.5.1** Protection Systems that act to trip the generator either directly or via lockout or auxiliary tripping relays.
 - 4.2.5.2** Protection Systems and Sudden Pressure Relaying for generator step-up transformers for generators that are part of the BES.
 - 4.2.5.3** Protection Systems and Sudden Pressure Relaying for station service or excitation transformers connected to the generator

bus of generators which are part of the BES, that act to trip the generator either directly or via lockout or tripping auxiliary relays.

4.2.6.1 **Rationale for 4.2.5:** In order to differentiate between typical BES generator Facilities and BES generators at dispersed power producing facilities, section 4.2.5 was separated into two sections (4.2.5 and 4.2.6). The applicability to non-dispersed power producing facilities has been maintained and can be found in 4.2.5. The applicability to dispersed power producing Facilities has been modified and relocated from 4.2.5 to 4.2.6.

Protection Systems for the following BES generator Facilities for dispersed power producing resources identified through Inclusion I4 of the BES definition:

4.2.6.1 Protection Systems for Facilities used in aggregating dispersed BES generation from the point where those resources aggregate to greater than 75 MVA to a common point of connection at 100 kV or above.

Rationale for 4.2.6: The Facilities listed that are applicable to dispersed power producing facilities are covered within 4.2.6. The intent is to NOT include the individual generating resources in the Protection System Maintenance Program, and as such the Protection Systems within the individual generating resources would not be within the scope of PRC-005. Only Protection Systems on equipment used in aggregating the dispersed BES generation from the point where those resources aggregate to greater than 75MVA to a common point of connection at 100kV would be included in the Protection System Maintenance Program, including the Protection Systems for those transformers used in aggregating generation.

t
Automatic Reclosing¹, including:

4.2.7.1 Automatic Reclosing applied on the terminals of Elements connected to the BES bus located at generating plant substations where the total installed gross generating plant capacity is greater than the gross capacity of the largest BES generating unit within the Balancing Authority Area.

4.2.7.2 Automatic Reclosing applied on the terminals of all BES Elements at substations one bus away from generating plants specified in Section 4.2.6.1 when the substation is less than 10 circuit-miles from the generating plant substation.

¹ Automatic Reclosing addressed in Section 4.2.7.1 and 4.2.7.2 may be excluded if the equipment owner can demonstrate that a close-in three-phase fault present for twice the normal clearing time (capturing a minimum trip-close-trip time delay) does not result in a total loss of gross generation in the Interconnection exceeding the gross capacity of the largest BES generating unit within the Balancing Authority Area where the Automatic Reclosing is applied.

4.2.6.3. Automatic Reclosing applied as an integral part of an SPS specified in Section 4.2.4.

5. Effective Date: See Implementation Plan.

6. Definitions Used in this Standard:

Automatic Reclosing – Includes the following Components:

- Reclosing relay
- Control circuitry associated with the reclosing relay.

Sudden Pressure Relaying – A system that trips an interrupting device(s) to isolate the equipment it is monitoring and includes the following Components:

- Fault pressure relay – a mechanical relay or device that detects rapid changes in gas pressure, oil pressure, or oil flow that are indicative of Faults within liquid-filled, wire-wound equipment
- Control circuitry associated with a fault pressure relay

Unresolved Maintenance Issue – A deficiency identified during a maintenance activity that causes the Component to not meet the intended performance, cannot be corrected during the maintenance interval, and requires follow-up corrective action.

Segment – Components of a consistent design standard, or a particular model or type from a single manufacturer that typically share other common elements. Consistent performance is expected across the entire population of a Segment. A Segment must contain at least sixty (60) individual Components.

Component Type –

- Any one of the five specific elements of a Protection System.
- Any one of the two specific elements of Automatic Reclosing.
- Any one of the two specific elements of Sudden Pressure Relaying.

Rationale for the deletion of part of the definition of Component: The SDT determined that it was explanatory in nature and adequately addressed in the Supplementary Reference and FAQ Document.

Component – Any individual discrete piece of equipment included in a Protection System, Automatic Reclosing, or Sudden Pressure Relaying.

Countable Event – A failure of a Component requiring repair or replacement, any condition discovered during the maintenance activities in Tables 1-1 through 1-5, Table 3, Tables 4-1 through 4-2, and Table 5, which requires corrective action or a Protection System Misoperation attributed to hardware failure or calibration failure.

Standard PRC-005-4(X) – Protection System, Automatic Reclosing, and Sudden Pressure Relaying Maintenance

Misoperations due to product design errors, software errors, relay settings different from specified settings, Protection System Component, Automatic Reclosing, or Sudden Pressure Relaying configuration or application errors are not included in Countable Events.

B. Requirements and Measures

- R1.** Each Transmission Owner, Generator Owner, and Distribution Provider shall establish a Protection System Maintenance Program (PSMP) for its Protection Systems, Automatic Reclosing, and Sudden Pressure Relaying identified in Section 4.2, Facilities. *[Violation Risk Factor: Medium] [Time Horizon: Operations Planning]*

The PSMP shall:

- 1.1.** Identify which maintenance method (time-based, performance-based per PRC-005 Attachment A, or a combination) is used to address each Protection System, Automatic Reclosing, and Sudden Pressure Relaying Component Type. All batteries associated with the station dc supply Component Type of a Protection System shall be included in a time-based program as described in Table 1-4 and Table 3.
 - 1.2.** Include the applicable monitored Component attributes applied to each Protection System, Automatic Reclosing, and Sudden Pressure Relaying Component Type consistent with the maintenance intervals specified in Tables 1-1 through 1-5, Table 2, Table 3, Table 4-1 through 4-2, and Table 5 where monitoring is used to extend the maintenance intervals beyond those specified for unmonitored Protection System, Automatic Reclosing, and Sudden Pressure Relaying Components.
- M1.** Each Transmission Owner, Generator Owner and Distribution Provider shall have a documented Protection System Maintenance Program in accordance with Requirement R1.

For each Protection System, Automatic Reclosing, and Sudden Pressure Relaying Component Type, the documentation shall include the type of maintenance method applied (time-based, performance-based, or a combination of these maintenance methods), and shall include all batteries associated with the station dc supply Component Types in a time-based program as described in Table 1-4 and Table 3. (Part 1.1)

For Component Types that use monitoring to extend the maintenance intervals, the responsible entity(s) shall have evidence for each Protection System, Automatic Reclosing, and Sudden Pressure Relaying Component Type (such as manufacturer's specifications or engineering drawings) of the appropriate monitored Component attributes as specified in Tables 1-1 through 1-5, Table 2, Table 3, Table 4-1 through 4-2, and Table 5. (Part 1.2)

Standard PRC-005-4(X) – Protection System, Automatic Reclosing, and Sudden Pressure Relaying Maintenance

- R2.** Each Transmission Owner, Generator Owner, and Distribution Provider that uses performance-based maintenance intervals in its PSMP shall follow the procedure established in PRC-005 Attachment A to establish and maintain its performance-based intervals. *[Violation Risk Factor: Medium] [Time Horizon: Operations Planning]*
- M2.** Each Transmission Owner, Generator Owner, and Distribution Provider that uses performance-based maintenance intervals shall have evidence that its current performance-based maintenance program(s) is in accordance with Requirement R2, which may include, but is not limited to, Component lists, dated maintenance records, and dated analysis records and results.

Rationale for R3 part 3.1 and 3.1.1.: The SDT, upon further reflection, determined that the PRC-005-3 Implementation Plan actually included a requirement that entities with newly-identified Automatic Reclosing Components implement its PSMP for those Components, and therefore determined that it was more appropriate to include this information in the standard rather than the implementation plan.

- R3.** Each Transmission Owner, Generator Owner, and Distribution Provider that utilizes time-based maintenance program(s) shall, except as provided in part 3.1, maintain its Protection System, Automatic Reclosing, and Sudden Pressure Relaying Components that are included within the time-based maintenance program in accordance with the minimum maintenance activities and maximum maintenance intervals prescribed within Tables 1-1 through 1-5, Table 2, Table 3, Table 4-1 through 4-2, and Table 5. *[Violation Risk Factor: High] [Time Horizon: Operations Planning]*
- 3.1.** For each newly-identified Automatic Reclosing Component following a notification under Requirement R6, each Transmission Owner, Generator Owner, and Distribution Provider shall perform maintenance activities or provide documentation of prior maintenance activities according to either 3.1.1 or 3.1.2.
- 3.1.1.** Complete the maintenance activities prescribed within Tables 4-1, 4-2(a), and 4-2(b) for the newly-identified Automatic Reclosing Component prior to the end of the third calendar year following the notification under Requirement R6; or
- 3.1.2.** Provide documentation that the Automatic Reclosing Component was last maintained in accordance with the minimum maintenance activities and maximum maintenance intervals prescribed within Tables 4-1, 4-2(a), and 4-2(b).
- M3.** Each Transmission Owner, Generator Owner, and Distribution Provider that utilizes time-based maintenance program(s) shall have evidence that it has maintained its Protection System, Automatic Reclosing, and Sudden Pressure Relaying Components included within its time-based program in accordance with Requirement R3. The evidence may include, but is not limited to, dated maintenance records, dated

Standard PRC-005-4(X) – Protection System, Automatic Reclosing, and Sudden Pressure Relaying Maintenance

maintenance summaries, dated check-off lists, dated inspection records, or dated work orders.

Rationale for R4 part 4.1 and 4.1.1.: The SDT, upon further reflection, determined that the PRC-005-3 Implementation Plan actually included a requirement that entities with newly-identified Automatic Reclosing Components implement its PSMP for those Components, and therefore determined that it was more appropriate to include this information in the standard rather than the implementation plan.

- R4.** Each Transmission Owner, Generator Owner, and Distribution Provider that utilizes performance-based maintenance program(s) in accordance with Requirement R2 shall, except as provided in part 4.1, implement and follow its PSMP for its Protection System, Automatic Reclosing, and Sudden Pressure Relaying Components that are included within the performance-based program(s). *[Violation Risk Factor: High]*
[Time Horizon: Operations Planning]
- 4.1.** For each newly-identified Automatic Reclosing Component following a notification under Requirement R6, each Transmission Owner, Generator Owner, and Distribution Provider shall perform maintenance activities or provide documentation of prior maintenance activities according to either 4.1.1 or 4.1.2.
- 4.1.1.** Complete the maintenance activities prescribed within Tables 4-1, 4-2(a), and 4-2(b) for the newly-identified Automatic Reclosing Component prior to the end of the third calendar year following the notification under Requirement R6; or
- 4.1.2.** Provide documentation that the Automatic Reclosing Component was last maintained in accordance with the minimum maintenance activities and maximum maintenance intervals prescribed within Tables 4-1, 4-2(a), and 4-2(b).
- M4.** Each Transmission Owner, Generator Owner, and Distribution Provider that utilizes performance-based maintenance intervals in accordance with Requirement R2 shall have evidence that it has implemented the Protection System Maintenance Program for the Protection System, Automatic Reclosing, and Sudden Pressure Relaying Components included in its performance-based program in accordance with Requirement R4. The evidence may include, but is not limited to, dated maintenance records, dated maintenance summaries, dated check-off lists, dated inspection records, or dated work orders.
- R5.** Each Transmission Owner, Generator Owner, and Distribution Provider shall demonstrate efforts to correct identified Unresolved Maintenance Issues. *[Violation Risk Factor: Medium]*
[Time Horizon: Operations Planning]
- M5.** Each Transmission Owner, Generator Owner, and Distribution Provider shall have evidence that it has undertaken efforts to correct identified Unresolved Maintenance

Standard PRC-005-4(X) – Protection System, Automatic Reclosing, and Sudden Pressure Relaying Maintenance

Issues in accordance with Requirement R5. The evidence may include, but is not limited to, work orders, replacement Component orders, invoices, project schedules with completed milestones, return material authorizations (RMAs) or purchase orders.

Rationale for R6: The information addressed in Requirement R6 is necessary for Transmission Owners, Generator Owners, and Distribution Provides to accurately apply Section 4.2.7, Applicability. The Balancing Authority is the entity that maintains the information and should have the responsibility to provide this information to the applicable entities. The drafting team reconsidered the inclusion of the Balancing Authority and determined it is appropriate to include the requirement the standard. This requirement may be relocated to another standard during future reviews of standards for quality and content.

The periodicity was chosen to balance the needs of the Transmission Owner, Generator Owner, and Distribution Provider to obtain the information with the needs of the Balancing Authority to provide an accurate gross capacity (considering retirement or installation of generating units and/or changes in its Balancing Authority Area) in order to properly include Automatic Reclosing in a PSMP.

- R6.** Each Balancing Authority shall, at least once every calendar year with not more than 15 calendar months between notifications, notify each Transmission Owner, Generator Owner, and Distribution Provider within its Balancing Authority Area of the gross capacity, in MW or MVA, of the largest BES generating unit within the Balancing Authority Area. [*Violation Risk Factor: Medium*] [*Time Horizon: Operations Planning*]
- M6.** Each Balancing Authority shall have dated documentation that it notified each Transmission Owner, Generator Owner, and Distribution Provider in accordance with Requirement R6. Examples of evidence may include, but are not limited to, copies of correspondence, such as e-mails or memoranda.

C. Compliance

1. Compliance Monitoring Process

1.1. Compliance Enforcement Authority

As defined in the NERC Rules of Procedure, “Compliance Enforcement Authority” means NERC or the Regional Entity in their respective roles of monitoring and enforcing compliance with the NERC Reliability Standards.

1.2. Evidence Retention

The following evidence retention periods identify the period of time an entity is required to retain specific evidence to demonstrate compliance. For instances where the evidence retention period specified below is shorter than the time

Standard PRC-005-4(X) – Protection System, Automatic Reclosing, and Sudden Pressure Relaying Maintenance

since the last audit, the Compliance Enforcement Authority may ask an entity to provide other evidence to show that it was compliant for the full time period since the last audit.

The Transmission Owner, Generator Owner, Distribution Provider, and Balancing Authority shall each keep data or evidence to show compliance as identified below unless directed by its Compliance Enforcement Authority to retain specific evidence for a longer period of time as part of an investigation.

For Requirement R1, the Transmission Owner, Generator Owner, and Distribution Provider shall each keep its current dated Protection System Maintenance Program, as well as any superseded versions since the preceding compliance audit, including the documentation that specifies the type of maintenance program applied for each Protection System Component Type.

For Requirement R2, Requirement R3, Requirement R4, and Requirement R5, the Transmission Owner, Generator Owner, and Distribution Provider shall each keep documentation of the most recent performance of each distinct maintenance activity for the Protection System, Automatic Reclosing, or Sudden Pressure Relaying Component, or all performances of each distinct maintenance activity for the Protection System, Automatic Reclosing, or Sudden Pressure Relaying Component since the previous scheduled audit date, whichever is longer.

For Requirement R6, the Balancing Authority shall keep documentation for three calendar years that it provided information identifying the largest BES generating unit to the Transmission Owners, Generator Owners, and Distribution Providers in its Balancing Authority Area.

The Compliance Enforcement Authority shall keep the last audit records and all requested and submitted subsequent audit records.

1.3. Compliance Monitoring and Assessment Processes:

- Compliance Audits
- Self-Certifications
- Spot Checking
- Compliance Violation Investigations
- Self-Reporting
- Complaints

1.4. Additional Compliance Information

None

Table of Compliance Elements

Requirement Number	Lower VSL	Moderate VSL	High VSL	Severe VSL
R1	The entity's PSMP failed to specify whether one Component Type is being addressed by time-based or performance-based maintenance, or a combination of both (part 1.1).	The entity's PSMP failed to specify whether two Component Types are being addressed by time-based or performance-based maintenance, or a combination of both (part 1.1).	<p>The entity's PSMP failed to specify whether three Component Types are being addressed by time-based or performance-based maintenance, or a combination of both. (part 1.1).</p> <p>OR</p> <p>The entity's PSMP failed to include the applicable monitoring attributes applied to each Component Type consistent with the maintenance intervals specified in Tables 1-1 through 1-5, Table 2, Table 3, Tables 4-1 through 4-2, and Table 5 where monitoring is used to extend the maintenance intervals beyond those specified for unmonitored Components (part 1.2).</p>	<p>The entity failed to establish a PSMP.</p> <p>OR</p> <p>The entity's PSMP failed to specify whether four or more Component Types are being addressed by time-based or performance-based maintenance, or a combination of both (part 1.1).</p> <p>OR</p> <p>The entity's PSMP failed to include applicable station batteries in a time-based program (part 1.1).</p>
R2	The entity uses performance-based maintenance intervals in its PSMP but failed to reduce Countable Events to no more than 4% within three years.	NA	The entity uses performance-based maintenance intervals in its PSMP but failed to reduce Countable Events to no more than 4% within four years.	<p>The entity uses performance-based maintenance intervals in its PSMP but:</p> <ol style="list-style-type: none"> 1) Failed to establish the technical justification described within Requirement R2 for the initial use of the performance-based PSMP <p>OR</p> <ol style="list-style-type: none"> 2) Failed to reduce Countable Events to no more than 4% within five years <p>OR</p> <ol style="list-style-type: none"> 3) Maintained a Segment with

Standard PRC-005-X(X) – Protection System, Automatic Reclosing, and Sudden Pressure Relaying Maintenance

Requirement Number	Lower VSL	Moderate VSL	High VSL	Severe VSL
				less than 60 Components OR 4) Failed to: <ul style="list-style-type: none"> • Annually update the list of Components, OR • Annually perform maintenance on the greater of 5% of the Segment population or 3 Components, OR • Annually analyze the program activities and results for each Segment.
R3	For Components included within a time-based maintenance program, the entity failed to maintain 5% or less of the total Components included within a specific Component Type in accordance with the minimum maintenance activities and maximum maintenance intervals prescribed within Tables 1-1 through 1-5, Table 2, Table 3, Tables 4-1 through 4-2, and Table 5. For Automatic Reclosing Components added to a time-based maintenance program per information from the Balancing Authority, the entity failed to	For Components included within a time-based maintenance program, the entity failed to maintain more than 5% but 10% or less of the total Components included within a specific Component Type in accordance with the minimum maintenance activities and maximum maintenance intervals prescribed within Tables 1-1 through 1-5, Table 2, Table 3, Tables 4-1 through 4-2, and Table 5. For Automatic Reclosing Components added to a time-based maintenance program per information from the Balancing	For Components included within a time-based maintenance program, the entity failed to maintain more than 10% but 15% or less of the total Components included within a specific Component Type in accordance with the minimum maintenance activities and maximum maintenance intervals prescribed within Tables 1-1 through 1-5, Table 2, Table 3, Tables 4-1 through 4-2, and Table 5. For Automatic Reclosing Components added to a time-based maintenance program per information from the Balancing	For Components included within a time-based maintenance program, the entity failed to maintain more than 15% of the total Components included within a specific Component Type in accordance with the minimum maintenance activities and maximum maintenance intervals prescribed within Tables 1-1 through 1-5, Table 2, Table 3, Tables 4-1 through 4-2, and Table 5. For Automatic Reclosing Components added to a time-based maintenance program per

Standard PRC-005-X(X) – Protection System, Automatic Reclosing, and Sudden Pressure Relaying Maintenance

Requirement Number	Lower VSL	Moderate VSL	High VSL	Severe VSL
	maintain 5% or less of the total Components in accordance with the minimum maintenance activities and maximum maintenance intervals prescribed within Tables 4-1 through 4-2.	Authority, the entity failed to maintain more than 5% but 10% or less of the total Components in accordance with the minimum maintenance activities and maximum maintenance intervals prescribed within Tables 4-1 through 4-2.	Authority, the entity failed to maintain more than 10% but 15% or less of the total Components in accordance with the minimum maintenance activities and maximum maintenance intervals prescribed within Tables 4-1 through 4-2.	information from the Balancing Authority, the entity failed to maintain more than 15% of the total Components in accordance with the minimum maintenance activities and maximum maintenance intervals prescribed within Tables 4-1 through 4-2.
R4	<p>For Components included within a performance-based maintenance program, the entity failed to maintain 5% or less of the annual scheduled maintenance for a specific Component Type in accordance with their performance-based PSMP.</p> <p>For Automatic Reclosing Components added to a performance-based maintenance program per information from the Balancing Authority, the entity failed to maintain 5% or less of the total Components in accordance with their performance-based PSMP.</p>	<p>For Components included within a performance-based maintenance program, the entity failed to maintain more than 5% but 10% or less of the annual scheduled maintenance for a specific Component Type in accordance with their performance-based PSMP.</p> <p>For Automatic Reclosing Components added to a performance-based maintenance program per information from the Balancing Authority, the entity failed to maintain more than 5% but 10% or less of the total Components in accordance with their performance-based PSMP.</p>	<p>For Components included within a performance-based maintenance program, the entity failed to maintain more than 10% but 15% or less of the annual scheduled maintenance for a specific Component Type in accordance with their performance-based PSMP.</p> <p>For Automatic Reclosing Components added to a performance-based maintenance program per information from the Balancing Authority, the entity failed to maintain more than 10% but 15% or less of the total Components in accordance with their performance-based PSMP.</p>	<p>For Components included within a performance-based maintenance program, the entity failed to maintain more than 15% of the annual scheduled maintenance for a specific Component Type in accordance with their performance-based PSMP.</p> <p>For Automatic Reclosing Components added to a performance-based maintenance program per information from the Balancing Authority, the entity failed to maintain more than 15% of the total Components in accordance with their performance-based PSMP.</p>
R5	The entity failed to undertake efforts to correct 5 or fewer identified Unresolved Maintenance Issues.	The entity failed to undertake efforts to correct greater than 5 but less than or equal to 10 identified	The entity failed to undertake efforts to correct greater than 10 but less than or equal to 15 identified Unresolved Maintenance	The entity failed to undertake efforts to correct greater than 15 identified Unresolved Maintenance

Standard PRC-005-X(X) – Protection System, Automatic Reclosing, and Sudden Pressure Relaying Maintenance

Requirement Number	Lower VSL	Moderate VSL	High VSL	Severe VSL
		Unresolved Maintenance Issues.	Issues.	Issues.
R6				<p>The entity failed to notify each Transmission Owner, Generator Owner, and Distribution Provider within its Balancing Authority Area at least once every calendar year of the gross capacity, in MW or MVA, of the largest BES generating unit within the Balancing Authority Area.</p> <p style="text-align: center;">OR</p> <p>The entity had more than 15 calendar months between notifications to each Transmission Owner, Generator Owner, and Distribution Provider of the gross capacity, in MW or MVA, of the largest BES generating unit within the Balancing Authority Area.</p>

D. Regional Variances

None.

E. Interpretations

None.

F. Supplemental Reference Documents

The following documents present a detailed discussion about determination of maintenance intervals and other useful information regarding establishment of a maintenance program.

Standard PRC-005-X(X) – Protection System, Automatic Reclosing, and Sudden Pressure Relaying Maintenance

1. *Supplementary Reference and FAQ - PRC-005-X Protection System Maintenance*, Protection System Maintenance and Testing Standard Drafting Team (April 2014)
2. *Considerations for Maintenance and Testing of Auto-reclosing Schemes*, NERC System Analysis and Modeling Subcommittee, and NERC System Protection and Control Subcommittee (November 2012)

Sudden Pressure Relays and Other Devices that Respond to Non-Electrical Quantities – SPCS Input for Standard Development in Response to FERC Order No. 758, NERC System Protection and Control Subcommittee (December 2013)

Version History

Version	Date	Action	Change Tracking
0	April 1, 2005	Effective Date	New
1	December 1, 2005	<ol style="list-style-type: none"> 1. Changed incorrect use of certain hyphens (-) to “en dash” (–) and “em dash (—).” 2. Added “periods” to items where appropriate. 3. Changed “Timeframe” to “Time Frame” in item D, 1.2. 	01/20/05
1a	February 17, 2011	Added Appendix 1 - Interpretation regarding applicability of standard to protection of radially connected transformers	Project 2009-17 interpretation
1a	February 17, 2011	Adopted by Board of Trustees	
1a	September 26, 2011	FERC Order issued approving interpretation of R1 and R2 (FERC’s Order is effective as of September 26, 2011)	
1.1b	May 9, 2012	PRC-005-1.1b was adopted by the Board of Trustees as part of Project 2010-07	

Standard PRC-005-X(X) – Protection System, Automatic Reclosing, and Sudden Pressure Relaying Maintenance

Version	Date	Action	Change Tracking
		(Generator Requirements at the Transmission Interface).	
2	November 7, 2012	Adopted by Board of Trustees	Project 2007-17 - Complete revision, absorbing maintenance requirements from PRC-005-1.1b, PRC-008-0, PRC-011-0, PRC-017-0
2	October 17, 2013	Errata Change: The Standards Committee approved an errata change to the implementation plan for PRC-005-2 to add the phrase “or as otherwise made effective pursuant to the laws applicable to such ERO governmental authorities;” to the second sentence under the “Retirement of Existing...”	
TBD (balloted as X(X))	TBD	Standard revised in Project 2014-01	Applicability section revised to clarify application of Requirements to BES dispersed power producing resources

Standard Development Timeline

This section is maintained by the drafting team during the development of the standard and will be removed when the standard becomes effective.

Development Steps Completed

1. SAR posted for comment November 20 – December 19, 2013.

Description of Current Draft

The Project 2014-01, Standards Applicability for Dispersed Generation Resources Standards Drafting Team (DGR SDT) is posting proposed applicability changes to PRC-005-3 for comment and ballot. This draft contains the DGR SDT’s recommended changes within the standard, which are intended to clarify application of the Requirements to Bulk Electric System (BES) dispersed power producing resources. Project 2014-01 does not have in its scope any technical content changes beyond revising the applicability to ensure consistent application of the Requirements of PRC-005 to dispersed power-producing resources.

In a parallel effort, the Protection System Maintenance and Testing Standard Drafting Team (PSMT SDT) has posted draft 1 of PRC-005-X for a 45-day comment period, and ballot in the last ten days of the comment period under the new Standards Process Manual (Effective: June 26, 2013).

Anticipated Actions	Anticipated Date
45-day Formal Comment Period with Initial Ballot	June – July 2014
45-day Additional Formal Comment Period with Additional Ballot (if necessary)	August – September 2014
Final ballot	October 2014
BOT adoption	November 2014

Definitions of Terms Used in Standard

This section includes all newly defined or revised terms used in the proposed standard. Terms already defined in the Reliability Standards Glossary of Terms (Glossary) are not repeated here. New or revised definitions listed below become approved when the proposed standard is approved. When the standard becomes effective, this defined term will be removed from the individual standard and added to the Glossary.

Protection System Maintenance Program (PSMP) — An ongoing program by which Protection System, Automatic Reclosing, and Sudden Pressure Relaying Components are kept in working order and proper operation of malfunctioning components is restored. A maintenance program for a specific Component includes one or more of the following activities:

- Verify — Determine that the Component is functioning correctly.
- Monitor — Observe the routine in-service operation of the Component.
- Test — Apply signals to a Component to observe functional performance or output behavior, or to diagnose problems.
- Inspect — Examine for signs of Component failure, reduced performance or degradation.
- Calibrate — Adjust the operating threshold or measurement accuracy of a measuring element to meet the intended performance requirement.

See Section A.6, Definitions Used in this Standard, for additional definitions that are new or modified for use within this standard.

Standard PRC-005-~~4(X)~~ – Protection System, Automatic Reclosing, and Sudden Pressure Relaying Maintenance

When this standard has received ballot approval, the text boxes will be moved to the Application Guidelines Section of the Standard.

A. Introduction

1. **Title:** **Protection System, Automatic Reclosing, and Sudden Pressure Relaying Maintenance**
2. **Number:** **PRC-005-X**
3. **Purpose:** To document and implement programs for the maintenance of all Protection Systems, Automatic Reclosing, and Sudden Pressure Relaying affecting the reliability of the Bulk Electric System (BES) so that they are kept in working order.
4. **Applicability:**
 - 4.1. **Functional Entities:**
 - 4.1.1 Transmission Owner
 - 4.1.2 Generator Owner
 - 4.1.3 Distribution Provider
 - 4.1.4 Balancing Authority
 - 4.2. **Facilities:**
 - 4.2.1 Protection Systems and Sudden Pressure Relaying that are installed for the purpose of detecting Faults on BES Elements (lines, buses, transformers, etc.)
 - 4.2.2 Protection Systems used for underfrequency load-shedding systems installed per ERO underfrequency load-shedding requirements.
 - 4.2.3 Protection Systems used for undervoltage load-shedding systems installed to prevent system voltage collapse or voltage instability for BES reliability.
 - 4.2.4 Protection Systems installed as a Special Protection System (SPS) for BES reliability.
 - 4.2.5 Protection Systems for the following BES generator Facilities that are part of the BES, including for generators not identified through Inclusion I4 of the BES definition:

The only revisions made to this version of PRC-005 are revisions to section 4.2, to clarify applicability of the Requirements of the standard at generator Facilities. These applicability revisions are intended to clarify and provide for consistent application of the Requirements to BES generator Facilities included in the BES through Inclusion I4 – Dispersed Power Producing Resources.

This version is labeled PRC-005-~~2(X)~~ for balloting purposes. The 'X' indicates that a version number will be applied at a later time, because multiple versions of PRC-005 are in development to reflect the fact that applicability changes need applied for versions of the standard that are approved (PRC-005-2), pending regulatory approval (PRC-005-3), and in development in Project 2007-17.3. Depending on the timing of approvals of other versions, NERC may file this interim version to provide regulatory certainty for entities as the revised BES definition is implemented.

4.2.5.1 Protection Systems that act to trip the generator either directly or via lockout or auxiliary tripping relays.

4.2.5.2 Protection Systems and Sudden Pressure Relaying for generator step-up transformers for generators that are part of the BES.

~~**4.2.5.3** Protection Systems for transformers connecting aggregated generation, where the aggregated generation is part of the BES (e.g., transformers connecting facilities such as wind farms to the BES).~~

4.2.5.3 -Protection Systems and Sudden Pressure Relaying for station service or excitation transformers connected to the generator bus of generators which are part of the BES, that act to trip the generator either directly or via lockout or tripping auxiliary relays.

Rationale for 4.2.5: In order to differentiate between typical BES generator Facilities and BES generators at dispersed power producing facilities, section 4.2.5 was separated into two sections (4.2.5 and 4.2.6). The applicability to non-dispersed power producing facilities has been maintained and can be found in 4.2.5. The applicability to dispersed power producing Facilities has been modified and relocated from 4.2.5 to 4.2.6.

4.2.6 Protection Systems for the following BES generator Facilities for dispersed power producing resources identified through Inclusion I4 of the BES definition:

4.2.6.1 Protection Systems for ~~electrical equipment~~Facilities- used in aggregating dispersed BES generation from the point where those resources aggregate to greater than 75 MVA to a common point of connection at 100 kV or above.

Rationale for 4.2.6: The Facilities listed that are applicable to dispersed power producing facilities are covered within 4.2.6. The intent is to NOT include the individual generating resources in the Protection System Maintenance Program, and as such the Protection Systems within the individual generating resources would not be within the scope of PRC-005. Only Protection Systems on equipment used in aggregating the dispersed BES generation from the point where those resources aggregate to greater than 75MVA to a common point of connection at 100kV would be included in the Protection System Maintenance Program, including the Protection Systems for those transformers used in aggregating generation.

4.2.6.2.7 Automatic Reclosing¹, including:

4.2.6.14.2.7.1 Automatic Reclosing applied on the terminals of Elements connected to the BES bus located at generating plant substations where the total installed gross generating plant capacity is greater than the gross capacity of the largest BES generating unit within the Balancing Authority Area.

4.2.6.24.2.7.2 Automatic Reclosing applied on the terminals of all BES Elements at substations one bus away from generating plants specified in Section 4.2.6.1 when the substation is less than 10 circuit-miles from the generating plant substation.

4.2.6.3. Automatic Reclosing applied as an integral part of an SPS specified in Section 4.2.4.

¹ Automatic Reclosing addressed in Section 4.2.7.1 and 4.2.7.2 may be excluded if the equipment owner can demonstrate that a close-in three-phase fault present for twice the normal clearing time (capturing a minimum trip-close-trip time delay) does not result in a total loss of gross generation in the Interconnection exceeding the gross capacity of the largest BES generating unit within the Balancing Authority Area where the Automatic Reclosing is applied.

5. **Effective Date:** See Implementation Plan.

6. **Definitions Used in this Standard:**

Automatic Reclosing – Includes the following Components:

- Reclosing relay
- Control circuitry associated with the reclosing relay.

Sudden Pressure Relaying – A system that trips an interrupting device(s) to isolate the equipment it is monitoring and includes the following Components:

- Fault pressure relay – a mechanical relay or device that detects rapid changes in gas pressure, oil pressure, or oil flow that are indicative of Faults within liquid-filled, wire-wound equipment
- Control circuitry associated with a fault pressure relay

Unresolved Maintenance Issue – A deficiency identified during a maintenance activity that causes the Component to not meet the intended performance, cannot be corrected during the maintenance interval, and requires follow-up corrective action.

Segment – Components of a consistent design standard, or a particular model or type from a single manufacturer that typically share other common elements. Consistent performance is expected across the entire population of a Segment. A Segment must contain at least sixty (60) individual Components.

Component Type –

- Any one of the five specific elements of a Protection System.
- Any one of the two specific elements of Automatic Reclosing.
- Any one of the two specific elements of Sudden Pressure Relaying.

<p>Rationale for the deletion of part of the definition of Component: The SDT determined that it was explanatory in nature and adequately addressed in the Supplementary Reference and FAQ Document.</p>

Component – Any individual discrete piece of equipment included in a Protection System, Automatic Reclosing, or Sudden Pressure Relaying.

Countable Event – A failure of a Component requiring repair or replacement, any condition discovered during the maintenance activities in Tables 1-1 through 1-5, Table 3, Tables 4-1 through 4-2, and Table 5, which requires corrective action or a Protection System Misoperation attributed to hardware failure or calibration failure.

Misoperations due to product design errors, software errors, relay settings different from specified settings, Protection System Component, Automatic Reclosing, or Sudden

Pressure Relaying configuration or application errors are not included in Countable Events.

B. Requirements and Measures

- R1.** Each Transmission Owner, Generator Owner, and Distribution Provider shall establish a Protection System Maintenance Program (PSMP) for its Protection Systems, Automatic Reclosing, and Sudden Pressure Relaying identified in Section 4.2, Facilities. *[Violation Risk Factor: Medium] [Time Horizon: Operations Planning]*

The PSMP shall:

- 1.1.** Identify which maintenance method (time-based, performance-based per PRC-005 Attachment A, or a combination) is used to address each Protection System, Automatic Reclosing, and Sudden Pressure Relaying Component Type. All batteries associated with the station dc supply Component Type of a Protection System shall be included in a time-based program as described in Table 1-4 and Table 3.
- 1.2.** Include the applicable monitored Component attributes applied to each Protection System, Automatic Reclosing, and Sudden Pressure Relaying Component Type consistent with the maintenance intervals specified in Tables 1-1 through 1-5, Table 2, Table 3, Table 4-1 through 4-2, and Table 5 where monitoring is used to extend the maintenance intervals beyond those specified for unmonitored Protection System, Automatic Reclosing, and Sudden Pressure Relaying Components.
- M1.** Each Transmission Owner, Generator Owner and Distribution Provider shall have a documented Protection System Maintenance Program in accordance with Requirement R1.

For each Protection System, Automatic Reclosing, and Sudden Pressure Relaying Component Type, the documentation shall include the type of maintenance method applied (time-based, performance-based, or a combination of these maintenance methods), and shall include all batteries associated with the station dc supply Component Types in a time-based program as described in Table 1-4 and Table 3. (Part 1.1)

For Component Types that use monitoring to extend the maintenance intervals, the responsible entity(s) shall have evidence for each Protection System, Automatic Reclosing, and Sudden Pressure Relaying Component Type (such as manufacturer's specifications or engineering drawings) of the appropriate monitored Component attributes as specified in Tables 1-1 through 1-5, Table 2, Table 3, Table 4-1 through 4-2, and Table 5. (Part 1.2)

- R2.** Each Transmission Owner, Generator Owner, and Distribution Provider that uses performance-based maintenance intervals in its PSMP shall follow the procedure

Standard PRC-005-4(X) – Protection System, Automatic Reclosing, and Sudden Pressure Relaying Maintenance

established in PRC-005 Attachment A to establish and maintain its performance-based intervals. *[Violation Risk Factor: Medium] [Time Horizon: Operations Planning]*

- M2.** Each Transmission Owner, Generator Owner, and Distribution Provider that uses performance-based maintenance intervals shall have evidence that its current performance-based maintenance program(s) is in accordance with Requirement R2, which may include, but is not limited to, Component lists, dated maintenance records, and dated analysis records and results.

Rationale for R3 part 3.1 and 3.1.1.: The SDT, upon further reflection, determined that the PRC-005-3 Implementation Plan actually included a requirement that entities with newly-identified Automatic Reclosing Components implement its PSMP for those Components, and therefore determined that it was more appropriate to include this information in the standard rather than the implementation plan.

- R3.** Each Transmission Owner, Generator Owner, and Distribution Provider that utilizes time-based maintenance program(s) shall, except as provided in part 3.1, maintain its Protection System, Automatic Reclosing, and Sudden Pressure Relaying Components that are included within the time-based maintenance program in accordance with the minimum maintenance activities and maximum maintenance intervals prescribed within Tables 1-1 through 1-5, Table 2, Table 3, Table 4-1 through 4-2, and Table 5. *[Violation Risk Factor: High] [Time Horizon: Operations Planning]*
- 3.1.** For each newly-identified Automatic Reclosing Component following a notification under Requirement R6, each Transmission Owner, Generator Owner, and Distribution Provider shall perform maintenance activities or provide documentation of prior maintenance activities according to either 3.1.1 or 3.1.2.
- 3.1.1.** Complete the maintenance activities prescribed within Tables 4-1, 4-2(a), and 4-2(b) for the newly-identified Automatic Reclosing Component prior to the end of the third calendar year following the notification under Requirement R6; or
- 3.1.2.** Provide documentation that the Automatic Reclosing Component was last maintained in accordance with the minimum maintenance activities and maximum maintenance intervals prescribed within Tables 4-1, 4-2(a), and 4-2(b).
- M3.** Each Transmission Owner, Generator Owner, and Distribution Provider that utilizes time-based maintenance program(s) shall have evidence that it has maintained its Protection System, Automatic Reclosing, and Sudden Pressure Relaying Components included within its time-based program in accordance with Requirement R3. The evidence may include, but is not limited to, dated maintenance records, dated

Standard PRC-005-4(X) – Protection System, Automatic Reclosing, and Sudden Pressure Relaying Maintenance

maintenance summaries, dated check-off lists, dated inspection records, or dated work orders.

Rationale for R4 part 4.1 and 4.1.1.: The SDT, upon further reflection, determined that the PRC-005-3 Implementation Plan actually included a requirement that entities with newly-identified Automatic Reclosing Components implement its PSMP for those Components, and therefore determined that it was more appropriate to include this information in the standard rather than the implementation plan.

- R4.** Each Transmission Owner, Generator Owner, and Distribution Provider that utilizes performance-based maintenance program(s) in accordance with Requirement R2 shall, except as provided in part 4.1, implement and follow its PSMP for its Protection System, Automatic Reclosing, and Sudden Pressure Relaying Components that are included within the performance-based program(s). [*Violation Risk Factor: High*] [*Time Horizon: Operations Planning*]
- 4.1.** For each newly-identified Automatic Reclosing Component following a notification under Requirement R6, each Transmission Owner, Generator Owner, and Distribution Provider shall perform maintenance activities or provide documentation of prior maintenance activities according to either 4.1.1 or 4.1.2.
- 4.1.1.** Complete the maintenance activities prescribed within Tables 4-1, 4-2(a), and 4-2(b) for the newly-identified Automatic Reclosing Component prior to the end of the third calendar year following the notification under Requirement R6; or
- 4.1.2.** Provide documentation that the Automatic Reclosing Component was last maintained in accordance with the minimum maintenance activities and maximum maintenance intervals prescribed within Tables 4-1, 4-2(a), and 4-2(b).
- M4.** Each Transmission Owner, Generator Owner, and Distribution Provider that utilizes performance-based maintenance intervals in accordance with Requirement R2 shall have evidence that it has implemented the Protection System Maintenance Program for the Protection System, Automatic Reclosing, and Sudden Pressure Relaying Components included in its performance-based program in accordance with Requirement R4. The evidence may include, but is not limited to, dated maintenance records, dated maintenance summaries, dated check-off lists, dated inspection records, or dated work orders.
- R5.** Each Transmission Owner, Generator Owner, and Distribution Provider shall demonstrate efforts to correct identified Unresolved Maintenance Issues. [*Violation Risk Factor: Medium*] [*Time Horizon: Operations Planning*]
- M5.** Each Transmission Owner, Generator Owner, and Distribution Provider shall have evidence that it has undertaken efforts to correct identified Unresolved Maintenance

Issues in accordance with Requirement R5. The evidence may include, but is not limited to, work orders, replacement Component orders, invoices, project schedules with completed milestones, return material authorizations (RMAs) or purchase orders.

Rationale for R6: The information addressed in Requirement R6 is necessary for Transmission Owners, Generator Owners, and Distribution Provides to accurately apply Section 4.2.7, Applicability. The Balancing Authority is the entity that maintains the information and should have the responsibility to provide this information to the applicable entities. The drafting team reconsidered the inclusion of the Balancing Authority and determined it is appropriate to include the requirement the standard. This requirement may be relocated to another standard during future reviews of standards for quality and content.

The periodicity was chosen to balance the needs of the Transmission Owner, Generator Owner, and Distribution Provider to obtain the information with the needs of the Balancing Authority to provide an accurate gross capacity (considering retirement or installation of generating units and/or changes in its Balancing Authority Area) in order to properly include Automatic Reclosing in a PSMP.

- R6.** Each Balancing Authority shall, at least once every calendar year with not more than 15 calendar months between notifications, notify each Transmission Owner, Generator Owner, and Distribution Provider within its Balancing Authority Area of the gross capacity, in MW or MVA, of the largest BES generating unit within the Balancing Authority Area. [*Violation Risk Factor: Medium*] [*Time Horizon: Operations Planning*]
- M6.** Each Balancing Authority shall have dated documentation that it notified each Transmission Owner, Generator Owner, and Distribution Provider in accordance with Requirement R6. Examples of evidence may include, but are not limited to, copies of correspondence, such as e-mails or memoranda.

C. Compliance

1. Compliance Monitoring Process

1.1. Compliance Enforcement Authority

As defined in the NERC Rules of Procedure, “Compliance Enforcement Authority” means NERC or the Regional Entity in their respective roles of monitoring and enforcing compliance with the NERC Reliability Standards.

1.2. Evidence Retention

The following evidence retention periods identify the period of time an entity is required to retain specific evidence to demonstrate compliance. For instances where the evidence retention period specified below is shorter than the time

since the last audit, the Compliance Enforcement Authority may ask an entity to provide other evidence to show that it was compliant for the full time period since the last audit.

The Transmission Owner, Generator Owner, Distribution Provider, and Balancing Authority shall each keep data or evidence to show compliance as identified below unless directed by its Compliance Enforcement Authority to retain specific evidence for a longer period of time as part of an investigation.

For Requirement R1, the Transmission Owner, Generator Owner, and Distribution Provider shall each keep its current dated Protection System Maintenance Program, as well as any superseded versions since the preceding compliance audit, including the documentation that specifies the type of maintenance program applied for each Protection System Component Type.

For Requirement R2, Requirement R3, Requirement R4, and Requirement R5, the Transmission Owner, Generator Owner, and Distribution Provider shall each keep documentation of the most recent performance of each distinct maintenance activity for the Protection System, Automatic Reclosing, or Sudden Pressure Relaying Component, or all performances of each distinct maintenance activity for the Protection System, Automatic Reclosing, or Sudden Pressure Relaying Component since the previous scheduled audit date, whichever is longer.

For Requirement R6, the Balancing Authority shall keep documentation for three calendar years that it provided information identifying the largest BES generating unit to the Transmission Owners, Generator Owners, and Distribution Providers in its Balancing Authority Area.

The Compliance Enforcement Authority shall keep the last audit records and all requested and submitted subsequent audit records.

1.3. Compliance Monitoring and Assessment Processes:

- Compliance Audits
- Self-Certifications
- Spot Checking
- Compliance Violation Investigations
- Self-Reporting
- Complaints

1.4. Additional Compliance Information

None

Table of Compliance Elements

Requirement Number	Lower VSL	Moderate VSL	High VSL	Severe VSL
R1	The entity's PSMP failed to specify whether one Component Type is being addressed by time-based or performance-based maintenance, or a combination of both (part 1.1).	The entity's PSMP failed to specify whether two Component Types are being addressed by time-based or performance-based maintenance, or a combination of both (part 1.1).	The entity's PSMP failed to specify whether three Component Types are being addressed by time-based or performance-based maintenance, or a combination of both. (part 1.1). OR The entity's PSMP failed to include the applicable monitoring attributes applied to each Component Type consistent with the maintenance intervals specified in Tables 1-1 through 1-5, Table 2, Table 3, Tables 4-1 through 4-2, and Table 5 where monitoring is used to extend the maintenance intervals beyond those specified for unmonitored Components (part 1.2).	The entity failed to establish a PSMP. OR The entity's PSMP failed to specify whether four or more Component Types are being addressed by time-based or performance-based maintenance, or a combination of both (part 1.1). OR The entity's PSMP failed to include applicable station batteries in a time-based program (part 1.1).
R2	The entity uses performance-based maintenance intervals in its PSMP but failed to reduce Countable Events to no more than 4% within three years.	NA	The entity uses performance-based maintenance intervals in its PSMP but failed to reduce Countable Events to no more than 4% within four years.	The entity uses performance-based maintenance intervals in its PSMP but: 1) Failed to establish the technical justification described within Requirement R2 for the initial use of the performance-based PSMP OR 2) Failed to reduce Countable Events to no more than 4% within five years OR

Standard PRC-005-4(X) – Protection System, Automatic Reclosing, and Sudden Pressure Relaying Maintenance

Requirement Number	Lower VSL	Moderate VSL	High VSL	Severe VSL
				3) Maintained a Segment with less than 60 Components OR 4) Failed to: <ul style="list-style-type: none"> • Annually update the list of Components, OR • Annually perform maintenance on the greater of 5% of the Segment population or 3 Components, OR • Annually analyze the program activities and results for each Segment.
R3	For Components included within a time-based maintenance program, the entity failed to maintain 5% or less of the total Components included within a specific Component Type in accordance with the minimum maintenance activities and maximum maintenance intervals prescribed within Tables 1-1 through 1-5, Table 2, Table 3, Tables 4-1 through 4-2, and Table 5. For Automatic Reclosing Components added to a time-based maintenance program per information from the Balancing	For Components included within a time-based maintenance program, the entity failed to maintain more than 5% but 10% or less of the total Components included within a specific Component Type in accordance with the minimum maintenance activities and maximum maintenance intervals prescribed within Tables 1-1 through 1-5, Table 2, Table 3, Tables 4-1 through 4-2, and Table 5. For Automatic Reclosing Components added to a time-based maintenance program per	For Components included within a time-based maintenance program, the entity failed to maintain more than 10% but 15% or less of the total Components included within a specific Component Type in accordance with the minimum maintenance activities and maximum maintenance intervals prescribed within Tables 1-1 through 1-5, Table 2, Table 3, Tables 4-1 through 4-2, and Table 5. For Automatic Reclosing Components added to a time-based maintenance program per	For Components included within a time-based maintenance program, the entity failed to maintain more than 15% of the total Components included within a specific Component Type in accordance with the minimum maintenance activities and maximum maintenance intervals prescribed within Tables 1-1 through 1-5, Table 2, Table 3, Tables 4-1 through 4-2, and Table 5. For Automatic Reclosing Components added to a time-

Standard PRC-005-4(X) – Protection System, Automatic Reclosing, and Sudden Pressure Relaying Maintenance

Requirement Number	Lower VSL	Moderate VSL	High VSL	Severe VSL
	<p>Authority, the entity failed to maintain 5% or less of the total Components in accordance with the minimum maintenance activities and maximum maintenance intervals prescribed within Tables 4-1 through 4-2.</p>	<p>information from the Balancing Authority, the entity failed to maintain more than 5% but 10% or less of the total Components in accordance with the minimum maintenance activities and maximum maintenance intervals prescribed within Tables 4-1 through 4-2.</p>	<p>information from the Balancing Authority, the entity failed to maintain more than 10% but 15% or less of the total Components in accordance with the minimum maintenance activities and maximum maintenance intervals prescribed within Tables 4-1 through 4-2.</p>	<p>based maintenance program per information from the Balancing Authority, the entity failed to maintain more than 15% of the total Components in accordance with the minimum maintenance activities and maximum maintenance intervals prescribed within Tables 4-1 through 4-2.</p>
R4	<p>For Components included within a performance-based maintenance program, the entity failed to maintain 5% or less of the annual scheduled maintenance for a specific Component Type in accordance with their performance-based PSMP.</p> <p>For Automatic Reclosing Components added to a performance-based maintenance program per information from the Balancing Authority, the entity failed to maintain 5% or less of the total Components in accordance with their performance-based PSMP.</p>	<p>For Components included within a performance-based maintenance program, the entity failed to maintain more than 5% but 10% or less of the annual scheduled maintenance for a specific Component Type in accordance with their performance-based PSMP.</p> <p>For Automatic Reclosing Components added to a performance-based maintenance program per information from the Balancing Authority, the entity failed to maintain more than 5% but 10% or less of the total Components in accordance with their performance-based PSMP.</p>	<p>For Components included within a performance-based maintenance program, the entity failed to maintain more than 10% but 15% or less of the annual scheduled maintenance for a specific Component Type in accordance with their performance-based PSMP.</p> <p>For Automatic Reclosing Components added to a performance-based maintenance program per information from the Balancing Authority, the entity failed to maintain more than 10% but 15% or less of the total Components in accordance with their performance-based PSMP.</p>	<p>For Components included within a performance-based maintenance program, the entity failed to maintain more than 15% of the annual scheduled maintenance for a specific Component Type in accordance with their performance-based PSMP.</p> <p>For Automatic Reclosing Components added to a performance-based maintenance program per information from the Balancing Authority, the entity failed to maintain more than 15% of the total Components in accordance with their performance-based PSMP.</p>

Standard PRC-005-4(X) – Protection System, Automatic Reclosing, and Sudden Pressure Relaying Maintenance

Requirement Number	Lower VSL	Moderate VSL	High VSL	Severe VSL
R5	The entity failed to undertake efforts to correct 5 or fewer identified Unresolved Maintenance Issues.	The entity failed to undertake efforts to correct greater than 5 but less than or equal to 10 identified Unresolved Maintenance Issues.	The entity failed to undertake efforts to correct greater than 10 but less than or equal to 15 identified Unresolved Maintenance Issues.	The entity failed to undertake efforts to correct greater than 15 identified Unresolved Maintenance Issues.
R6				<p>The entity failed to notify each Transmission Owner, Generator Owner, and Distribution Provider within its Balancing Authority Area at least once every calendar year of the gross capacity, in MW or MVA, of the largest BES generating unit within the Balancing Authority Area.</p> <p style="text-align: center;">OR</p> <p>The entity had more than 15 calendar months between notifications to each Transmission Owner, Generator Owner, and Distribution Provider of the gross capacity, in MW or MVA, of the largest BES generating unit within the Balancing Authority Area.</p>

D. Regional Variances

None.

E. Interpretations

None.

F. Supplemental Reference Documents

Standard PRC-005-4(X) – Protection System, Automatic Reclosing, and Sudden Pressure Relaying Maintenance

The following documents present a detailed discussion about determination of maintenance intervals and other useful information regarding establishment of a maintenance program.

1. *Supplementary Reference and FAQ - PRC-005-X Protection System Maintenance*, Protection System Maintenance and Testing Standard Drafting Team (April 2014)
2. *Considerations for Maintenance and Testing of Auto-reclosing Schemes*, NERC System Analysis and Modeling Subcommittee, and NERC System Protection and Control Subcommittee (November 2012)

Sudden Pressure Relays and Other Devices that Respond to Non-Electrical Quantities – SPCS Input for Standard Development in Response to FERC Order No. 758, NERC System Protection and Control Subcommittee (December 2013)

Version History

Version	Date	Action	Change Tracking
0	April 1, 2005	Effective Date	New
1	December 1, 2005	<ol style="list-style-type: none">1. Changed incorrect use of certain hyphens (-) to “en dash” (–) and “em dash (—).”2. Added “periods” to items where appropriate.3. Changed “Timeframe” to “Time Frame” in item D, 1.2.	01/20/05
1a	February 17, 2011	Added Appendix 1 - Interpretation regarding applicability of standard to protection of radially connected transformers	Project 2009-17 interpretation
1a	February 17, 2011	Adopted by Board of Trustees	

Standard PRC-005-4(X) – Protection System, Automatic Reclosing, and Sudden Pressure Relaying Maintenance

Version	Date	Action	Change Tracking
<u>1a</u>	<u>September 26, 2011</u>	<u>FERC Order issued approving interpretation of R1 and R2 (FERC's Order is effective as of September 26, 2011)</u>	
<u>1.1b</u>	<u>May 9, 2012</u>	<u>PRC-005-1.1b was adopted by the Board of Trustees as part of Project 2010-07 (Generator Requirements at the Transmission Interface).</u>	
<u>2</u>	<u>November 7, 2012</u>	<u>Adopted by Board of Trustees</u>	<u>Project 2007-17 - Complete revision, absorbing maintenance requirements from PRC-005-1.1b, PRC-008-0, PRC-011-0, PRC-017-0</u>
<u>2</u>	<u>October 17, 2013</u>	<u>Errata Change: The Standards Committee approved an errata change to the implementation plan for PRC-005-2 to add the phrase "or as otherwise made effective pursuant to the laws applicable to such ERO governmental authorities;" to the second sentence under the "Retirement of Existing..."</u>	
<u>TBD (balloted as 4(X))</u>	<u>TBD</u>	<u>Standard revised in Project 2014-01</u>	<u>Applicability section revised to clarify application of Requirements to BES dispersed power producing resources</u>
1a	September 26, 2011	FERC Order issued approving interpretation of R1 and R2 (FERC's Order is effective as of September 26, 2011)	
<u>1.1a</u>	<u>February 1, 2012</u>	<u>Errata change: Clarified inclusion of generator interconnection Facility in Generator Owner's responsibility</u>	<u>Revision under Project 2010-07</u>

Standard PRC-005-4(X) – Protection System, Automatic Reclosing, and Sudden Pressure Relaying Maintenance

Version	Date	Action	Change Tracking
1b	February 3, 2012	FERC Order issued approving interpretation of R1, R1.1, and R1.2 (FERC's Order dated March 14, 2012). Updated version from 1a to 1b.	Project 2009-10 Interpretation
1.1b	April 23, 2012	Updated standard version to 1.1b to reflect FERC approval of PRC-005-1b.	Revision under Project 2010-07

Standard PRC-005-4(X) – Protection System, Automatic Reclosing, and Sudden Pressure Relaying Maintenance

Version	Date	Action	Change Tracking
1.1b	May 9, 2012	PRC-005-1.1b was adopted by the Board of Trustees as part of Project 2010-07 (Generator Requirements at the Transmission Interface).	
2	November 7, 2012	Adopted by Board of Trustees	Project 2007-17—Complete revision, absorbing maintenance requirements from PRC-005-1.1b, PRC-008-0, PRC-011-0, PRC-017-0
2	October 17, 2013	Errata Change: The Standards Committee approved an errata change to the implementation plan for PRC-005-2 to add the phrase “or as otherwise made effective pursuant to the laws applicable to such ERO governmental authorities;” to the second sentence under the “Retirement of Existing	
3	November 7, 2013	Adopted by the NERC Board of Trustees	Revised to address the FERC directive in Order No.758 to include Automatic Reclosing in maintenance programs.
3.1	February 12, 2014	Approved by the Standards Committee	Errata changes to correct capitalization of defined terms

Standard PRC-005-4(X) – Protection System, Automatic Reclosing, and Sudden Pressure Relaying Maintenance

Version	Date	Action	Change Tracking
4			Project 2007-17.3 – Revised to address the FERC directive in Order No. 758 to include sudden pressure relays in maintenance programs.
<u>TBD (balloted as 2(X))</u>	<u>TBD</u>	Standard revised in Project 2014-01-	<u>Applicability section revised to clarify application of Requirements to BES dispersed power producing resources</u>

Table 1-1 Component Type - Protective Relay Excluding distributed UFLS and distributed UVLS (see Table 3)		
Component Attributes	Maximum Maintenance Interval²	Maintenance Activities
Any unmonitored protective relay not having all the monitoring attributes of a category below.	6 Calendar Years	For all unmonitored relays: <ul style="list-style-type: none"> • Verify that settings are as specified For non-microprocessor relays: <ul style="list-style-type: none"> • Test and, if necessary calibrate For microprocessor relays: <ul style="list-style-type: none"> • Verify operation of the relay inputs and outputs that are essential to proper functioning of the Protection System. • Verify acceptable measurement of power system input values.
Monitored microprocessor protective relay with the following: <ul style="list-style-type: none"> • Internal self-diagnosis and alarming (see Table 2). • Voltage and/or current waveform sampling three or more times per power cycle, and conversion of samples to numeric values for measurement calculations by microprocessor electronics. • Alarming for power supply failure (see Table 2). 	12 Calendar Years	Verify: <ul style="list-style-type: none"> • Settings are as specified. • Operation of the relay inputs and outputs that are essential to proper functioning of the Protection System. • Acceptable measurement of power system input values.

² For the tables in this standard, a calendar year starts on the first day of a new year (January 1) after a maintenance activity has been completed. For the tables in this standard, a calendar month starts on the first day of the first month after a maintenance activity has been completed.

Table 1-1 Component Type - Protective Relay Excluding distributed UFLS and distributed UVLS (see Table 3)		
Component Attributes	Maximum Maintenance Interval ²	Maintenance Activities
Monitored microprocessor protective relay with preceding row attributes and the following: <ul style="list-style-type: none"> • Ac measurements are continuously verified by comparison to an independent ac measurement source, with alarming for excessive error (See Table 2). • Some or all binary or status inputs and control outputs are monitored by a process that continuously demonstrates ability to perform as designed, with alarming for failure (See Table 2). • Alarming for change of settings (See Table 2). 	12 Calendar Years	Verify only the unmonitored relay inputs and outputs that are essential to proper functioning of the Protection System.

Table 1-2 Component Type - Communications Systems Excluding distributed UFLS and distributed UVLS (see Table 3)		
Component Attributes	Maximum Maintenance Interval	Maintenance Activities
Any unmonitored communications system necessary for correct operation of protective functions, and not having all the monitoring attributes of a category below.	4 Calendar Months	Verify that the communications system is functional.
	6 Calendar Years	Verify that the communications system meets performance criteria pertinent to the communications technology applied (e.g. signal level, reflected power, or data error rate). Verify operation of communications system inputs and outputs that are essential to proper functioning of the Protection System.
Any communications system with continuous monitoring or periodic automated testing for the presence of the channel function, and alarming for loss of function (See Table 2).	12 Calendar Years	Verify that the communications system meets performance criteria pertinent to the communications technology applied (e.g. signal level, reflected power, or data error rate). Verify operation of communications system inputs and outputs that are essential to proper functioning of the Protection System.
Any communications system with all of the following: <ul style="list-style-type: none"> • Continuous monitoring or periodic automated testing for the performance of the channel using criteria pertinent to the communications technology applied (e.g. signal level, reflected power, or data error rate, and alarming for excessive performance degradation). (See Table 2) • Some or all binary or status inputs and control outputs are monitored by a process that continuously demonstrates ability to perform as designed, with alarming for failure (See Table 2). 	12 Calendar Years	Verify only the unmonitored communications system inputs and outputs that are essential to proper functioning of the Protection System

Table 1-3 Component Type - Voltage and Current Sensing Devices Providing Inputs to Protective Relays Excluding distributed UFLS and distributed UVLS (see Table 3)		
Component Attributes	Maximum Maintenance Interval	Maintenance Activities
Any voltage and current sensing devices not having monitoring attributes of the category below.	12 Calendar Years	Verify that current and voltage signal values are provided to the protective relays.
Voltage and Current Sensing devices connected to microprocessor relays with AC measurements are continuously verified by comparison of sensing input value, as measured by the microprocessor relay, to an independent ac measurement source, with alarming for unacceptable error or failure (see Table 2).	No periodic maintenance specified	None.

Table 1-4(a) Component Type – Protection System Station dc Supply Using Vented Lead-Acid (VLA) Batteries Excluding distributed UFLS and distributed UVLS (see Table 3)		
Protection System Station dc supply used only for non-BES interrupting devices for SPS, non-distributed UFLS systems, or non-distributed UVLS systems is excluded (see Table 1-4(e)).		
Component Attributes	Maximum Maintenance Interval	Maintenance Activities
Protection System Station dc supply using Vented Lead-Acid (VLA) batteries not having monitoring attributes of Table 1-4(f).	4 Calendar Months	Verify: <ul style="list-style-type: none"> • Station dc supply voltage Inspect: <ul style="list-style-type: none"> • Electrolyte level • For unintentional grounds
	18 Calendar Months	Verify: <ul style="list-style-type: none"> • Float voltage of battery charger • Battery continuity • Battery terminal connection resistance • Battery intercell or unit-to-unit connection resistance Inspect: <ul style="list-style-type: none"> • Cell condition of all individual battery cells where cells are visible – or measure battery cell/unit internal ohmic values where the cells are not visible • Physical condition of battery rack

Table 1-4(a) Component Type – Protection System Station dc Supply Using Vented Lead-Acid (VLA) Batteries Excluding distributed UFLS and distributed UVLS (see Table 3)		
Protection System Station dc supply used only for non-BES interrupting devices for SPS, non-distributed UFLS systems, or non-distributed UVLS systems is excluded (see Table 1-4(e)).		
Component Attributes	Maximum Maintenance Interval	Maintenance Activities
	18 Calendar Months -or- 6 Calendar Years	Verify that the station battery can perform as manufactured by evaluating cell/unit measurements indicative of battery performance (e.g. internal ohmic values or float current) against the station battery baseline. -or- Verify that the station battery can perform as manufactured by conducting a performance or modified performance capacity test of the entire battery bank.

Table 1-4(b) Component Type – Protection System Station dc Supply Using Valve-Regulated Lead-Acid (VRLA) Batteries Excluding distributed UFLS and distributed UVLS (see Table 3)		
Protection System Station dc supply used only for non-BES interrupting devices for SPS, non-distributed UFLS systems, or non-distributed UVLS systems is excluded (see Table 1-4(e)).		
Component Attributes	Maximum Maintenance Interval	Maintenance Activities
Protection System Station dc supply with Valve Regulated Lead-Acid (VRLA) batteries not having monitoring attributes of Table 1-4(f).	4 Calendar Months	Verify: <ul style="list-style-type: none"> • Station dc supply voltage Inspect: <ul style="list-style-type: none"> • For unintentional grounds
	6 Calendar Months	Inspect: <ul style="list-style-type: none"> • Condition of all individual units by measuring battery cell/unit internal ohmic values.
	18 Calendar Months	Verify: <ul style="list-style-type: none"> • Float voltage of battery charger • Battery continuity • Battery terminal connection resistance • Battery intercell or unit-to-unit connection resistance Inspect: <ul style="list-style-type: none"> • Physical condition of battery rack

Table 1-4(b) Component Type – Protection System Station dc Supply Using Valve-Regulated Lead-Acid (VRLA) Batteries Excluding distributed UFLS and distributed UVLS (see Table 3)		
Protection System Station dc supply used only for non-BES interrupting devices for SPS, non-distributed UFLS systems, or non-distributed UVLS systems is excluded (see Table 1-4(e)).		
Component Attributes	Maximum Maintenance Interval	Maintenance Activities
	6 Calendar Months -or- 3 Calendar Years	Verify that the station battery can perform as manufactured by evaluating cell/unit measurements indicative of battery performance (e.g. internal ohmic values or float current) against the station battery baseline. -or- Verify that the station battery can perform as manufactured by conducting a performance or modified performance capacity test of the entire battery bank.

Table 1-4(c) Component Type – Protection System Station dc Supply Using Nickel-Cadmium (NiCad) Batteries Excluding distributed UFLS and distributed UVLS (see Table 3)		
Protection System Station dc supply used only for non-BES interrupting devices for SPS, non-distributed UFLS system, or non-distributed UVLS systems is excluded (see Table 1-4(e)).		
Component Attributes	Maximum Maintenance Interval	Maintenance Activities
Protection System Station dc supply Nickel-Cadmium (NiCad) batteries not having monitoring attributes of Table 1-4(f).	4 Calendar Months	Verify: <ul style="list-style-type: none"> • Station dc supply voltage Inspect: <ul style="list-style-type: none"> • Electrolyte level • For unintentional grounds
	18 Calendar Months	Verify: <ul style="list-style-type: none"> • Float voltage of battery charger • Battery continuity • Battery terminal connection resistance • Battery intercell or unit-to-unit connection resistance Inspect: <ul style="list-style-type: none"> • Cell condition of all individual battery cells. • Physical condition of battery rack

Table 1-4(c) Component Type – Protection System Station dc Supply Using Nickel-Cadmium (NiCad) Batteries Excluding distributed UFLS and distributed UVLS (see Table 3)		
Protection System Station dc supply used only for non-BES interrupting devices for SPS, non-distributed UFLS system, or non-distributed UVLS systems is excluded (see Table 1-4(e)).		
Component Attributes	Maximum Maintenance Interval	Maintenance Activities
	6 Calendar Years	Verify that the station battery can perform as manufactured by conducting a performance or modified performance capacity test of the entire battery bank.

Table 1-4(d) Component Type – Protection System Station dc Supply Using Non Battery Based Energy Storage Excluding distributed UFLS and distributed UVLS (see Table 3) Protection System Station dc supply used only for non-BES interrupting devices for SPS, non-distributed UFLS system, or non-distributed UVLS systems is excluded (see Table 1-4(e)).		
Component Attributes	Maximum Maintenance Interval	Maintenance Activities
Any Protection System station dc supply not using a battery and not having monitoring attributes of Table 1-4(f).	4 Calendar Months	Verify: <ul style="list-style-type: none"> • Station dc supply voltage Inspect: <ul style="list-style-type: none"> • For unintentional grounds
	18 Calendar Months	Inspect: Condition of non-battery based dc supply
	6 Calendar Years	Verify that the dc supply can perform as manufactured when ac power is not present.

Table 1-4(e) Component Type – Protection System Station dc Supply for non-BES Interrupting Devices for SPS, non-distributed UFLS, and non-distributed UVLS systems		
Component Attributes	Maximum Maintenance Interval	Maintenance Activities
Any Protection System dc supply used for tripping only non-BES interrupting devices as part of a SPS, non-distributed UFLS, or non-distributed UVLS system and not having monitoring attributes of Table 1-4(f).	When control circuits are verified (See Table 1-5)	Verify Station dc supply voltage.

Table 1-4(f) Exclusions for Protection System Station dc Supply Monitoring Devices and Systems		
Component Attributes	Maximum Maintenance Interval	Maintenance Activities
Any station dc supply with high and low voltage monitoring and alarming of the battery charger voltage to detect charger overvoltage and charger failure (See Table 2).	No periodic maintenance specified	No periodic verification of station dc supply voltage is required.
Any battery based station dc supply with electrolyte level monitoring and alarming in every cell (See Table 2).		No periodic inspection of the electrolyte level for each cell is required.
Any station dc supply with unintentional dc ground monitoring and alarming (See Table 2).		No periodic inspection of unintentional dc grounds is required.
Any station dc supply with charger float voltage monitoring and alarming to ensure correct float voltage is being applied on the station dc supply (See Table 2).		No periodic verification of float voltage of battery charger is required.
Any battery based station dc supply with monitoring and alarming of battery string continuity (See Table 2).		No periodic verification of the battery continuity is required.
Any battery based station dc supply with monitoring and alarming of the intercell and/or terminal connection detail resistance of the entire battery (See Table 2).		No periodic verification of the intercell and terminal connection resistance is required.
Any Valve Regulated Lead-Acid (VRLA) or Vented Lead-Acid (VLA) station battery with internal ohmic value or float current monitoring and alarming, and evaluating present values relative to baseline internal ohmic values for every cell/unit (See Table 2).		No periodic evaluation relative to baseline of battery cell/unit measurements indicative of battery performance is required to verify the station battery can perform as manufactured.
Any Valve Regulated Lead-Acid (VRLA) or Vented Lead-Acid (VLA) station battery with monitoring and alarming of each cell/unit internal ohmic value (See Table 2).		No periodic inspection of the condition of all individual units by measuring battery cell/unit internal ohmic values of a station VRLA or Vented Lead-Acid (VLA) battery is required.

Table 1-5 Component Type - Control Circuitry Associated With Protective Functions Excluding distributed UFLS and distributed UVLS (see Table 3) Note: Table requirements apply to all Control Circuitry Components of Protection Systems, and SPSs except as noted.		
Component Attributes	Maximum Maintenance Interval	Maintenance Activities
Trip coils or actuators of circuit breakers, interrupting devices, or mitigating devices (regardless of any monitoring of the control circuitry).	6 Calendar Years	Verify that each trip coil is able to operate the circuit breaker, interrupting device, or mitigating device.
Electromechanical lockout devices which are directly in a trip path from the protective relay to the interrupting device trip coil (regardless of any monitoring of the control circuitry).	6 Calendar Years	Verify electrical operation of electromechanical lockout devices.
Unmonitored control circuitry associated with SPS. (See Table 4-2(b) for SPS which include Automatic Reclosing.)	12 Calendar Years	Verify all paths of the control circuits essential for proper operation of the SPS.
Unmonitored control circuitry associated with protective functions inclusive of all auxiliary relays.	12 Calendar Years	Verify all paths of the trip circuits inclusive of all auxiliary relays through the trip coil(s) of the circuit breakers or other interrupting devices.
Control circuitry associated with protective functions and/or SPSs whose integrity is monitored and alarmed (See Table 2).	No periodic maintenance specified	None.

Table 2 – Alarming Paths and Monitoring		
In Tables 1-1 through 1-5, Table 3, and Tables 4-1 through 4-2, alarm attributes used to justify extended maximum maintenance intervals and/or reduced maintenance activities are subject to the following maintenance requirements		
Component Attributes	Maximum Maintenance Interval	Maintenance Activities
<p>Any alarm path through which alarms in Tables 1-1 through 1-5, Table 3, and Tables 4-1 through 4-2 are conveyed from the alarm origin to the location where corrective action can be initiated, and not having all the attributes of the “Alarm Path with monitoring” category below.</p> <p>Alarms are reported within 24 hours of detection to a location where corrective action can be initiated.</p>	12 Calendar Years	Verify that the alarm path conveys alarm signals to a location where corrective action can be initiated.
<p>Alarm Path with monitoring:</p> <p>The location where corrective action is taken receives an alarm within 24 hours for failure of any portion of the alarming path from the alarm origin to the location where corrective action can be initiated.</p>	No periodic maintenance specified	None.

Table 3 Maintenance Activities and Intervals for distributed UFLS and distributed UVLS Systems		
Component Attributes	Maximum Maintenance Interval	Maintenance Activities
Any unmonitored protective relay not having all the monitoring attributes of a category below.	6 Calendar Years	<p>Verify that settings are as specified.</p> <p>For non-microprocessor relays:</p> <ul style="list-style-type: none"> • Test and, if necessary calibrate. <p>For microprocessor relays:</p> <ul style="list-style-type: none"> • Verify operation of the relay inputs and outputs that are essential to proper functioning of the Protection System. • Verify acceptable measurement of power system input values.
<p>Monitored microprocessor protective relay with the following:</p> <ul style="list-style-type: none"> • Internal self-diagnosis and alarming (See Table 2). • Voltage and/or current waveform sampling three or more times per power cycle, and conversion of samples to numeric values for measurement calculations by microprocessor electronics. <p>Alarming for power supply failure (See Table 2).</p>	12 Calendar Years	<p>Verify:</p> <ul style="list-style-type: none"> • Settings are as specified. • Operation of the relay inputs and outputs that are essential to proper functioning of the Protection System. • Acceptable measurement of power system input values
<p>Monitored microprocessor protective relay with preceding row attributes and the following:</p> <ul style="list-style-type: none"> • Ac measurements are continuously verified by comparison to an independent ac measurement source, with alarming for excessive error (See Table 2). 	12 Calendar Years	<p>Verify only the unmonitored relay inputs and outputs that are essential to proper functioning of the Protection System.</p>

Standard PRC-005-4(X) – Protection System, Automatic Reclosing, and Sudden Pressure Relaying Maintenance

Table 3 Maintenance Activities and Intervals for distributed UFLS and distributed UVLS Systems		
Component Attributes	Maximum Maintenance Interval	Maintenance Activities
<ul style="list-style-type: none"> Some or all binary or status inputs and control outputs are monitored by a process that continuously demonstrates ability to perform as designed, with alarming for failure (See Table 2). Alarming for change of settings (See Table 2).		
Voltage and/or current sensing devices associated with UFLS or UVLS systems.	12 Calendar Years	Verify that current and/or voltage signal values are provided to the protective relays.
Protection System dc supply for tripping non-BES interrupting devices used only for a UFLS or UVLS system.	12 Calendar Years	Verify Protection System dc supply voltage.
Control circuitry between the UFLS or UVLS relays and electromechanical lockout and/or tripping auxiliary devices (excludes non-BES interrupting device trip coils).	12 Calendar Years	Verify the path from the relay to the lockout and/or tripping auxiliary relay (including essential supervisory logic).
Electromechanical lockout and/or tripping auxiliary devices associated only with UFLS or UVLS systems (excludes non-BES interrupting device trip coils).	12 Calendar Years	Verify electrical operation of electromechanical lockout and/or tripping auxiliary devices.
Control circuitry between the electromechanical lockout and/or tripping auxiliary devices and the non-BES interrupting devices in UFLS or UVLS systems, or between UFLS or UVLS relays (with no interposing electromechanical lockout or auxiliary device) and the non-BES interrupting devices (excludes non-BES interrupting device trip coils).	No periodic maintenance specified	None.
Trip coils of non-BES interrupting devices in UFLS or UVLS systems.	No periodic maintenance specified	None.

Table 4-1 Maintenance Activities and Intervals for Automatic Reclosing Components Component Type – Reclosing Relay		
Component Attributes	Maximum Maintenance Interval	Maintenance Activities
Any unmonitored reclosing relay not having all the monitoring attributes of a category below.	6 Calendar Years	Verify that settings are as specified. For non-microprocessor relays: <ul style="list-style-type: none"> • Test and, if necessary calibrate For microprocessor relays: <ul style="list-style-type: none"> • Verify operation of the relay inputs and outputs that are essential to proper functioning of the Automatic Reclosing.
Monitored microprocessor reclosing relay with the following: <ul style="list-style-type: none"> • Internal self-diagnosis and alarming (See Table 2). • Alarming for power supply failure (See Table 2). 	12 Calendar Years	Verify: <ul style="list-style-type: none"> • Settings are as specified. • Operation of the relay inputs and outputs that are essential to proper functioning of the Automatic Reclosing.

Table 4-2(a) Maintenance Activities and Intervals for Automatic Reclosing Components Component Type – Control Circuitry Associated with Reclosing Relays that are NOT an Integral Part of an SPS		
Component Attributes	Maximum Maintenance Interval	Maintenance Activities
Unmonitored Control circuitry associated with Automatic Reclosing that is not an integral part of an SPS.	12 Calendar Years	Verify that Automatic Reclosing, upon initiation, does not issue a premature closing command to the close circuitry.
Control circuitry associated with Automatic Reclosing that is not part of an SPS and is monitored and alarmed for conditions that would result in a premature closing command. (See Table 2)	No periodic maintenance specified	None.

Table 4-2(b) Maintenance Activities and Intervals for Automatic Reclosing Components Component Type – Control Circuitry Associated with Reclosing Relays that ARE an Integral Part of an SPS		
Component Attributes	Maximum Maintenance Interval	Maintenance Activities
Close coils or actuators of circuit breakers or similar devices that are used in conjunction with Automatic Reclosing as part of an SPS (regardless of any monitoring of the control circuitry).	6 Calendar Years	Verify that each close coil or actuator is able to operate the circuit breaker or mitigating device.
Unmonitored close control circuitry associated with Automatic Reclosing used as an integral part of an SPS.	12 Calendar Years	Verify all paths of the control circuits associated with Automatic Reclosing that are essential for proper operation of the SPS.
Control circuitry associated with Automatic Reclosing that is an integral part of an SPS whose integrity is monitored and alarmed. (See Table 2)	No periodic maintenance specified	None.

Table 5 Maintenance Activities and Intervals for Sudden Pressure Relaying		
Component Attributes	Maximum Maintenance Interval	Maintenance Activities
Any fault pressure relay.	6 Calendar Years	Verify the pressure or flow sensing mechanism is operable.
Control circuitry associated with Sudden Pressure Relaying from the fault pressure relay to the interrupting device trip coil(s).	12 Calendar Years	Verify all paths of the control circuits that are essential for proper operation of the Sudden Pressure Relaying.

PRC-005 — Attachment A

Criteria for a Performance-Based Protection System Maintenance Program

Purpose: To establish a technical basis for initial and continued use of a performance-based Protection System Maintenance Program (PSMP).

To establish the technical justification for the initial use of a performance-based PSMP:

1. Develop a list with a description of Components included in each designated Segment, with a minimum **Segment** population of 60 Components.
2. Maintain the Components in each Segment according to the time-based maximum allowable intervals established in Tables 1-1 through 1-5, Table 3, Tables 4-1 through 4-2, and Table 5 until results of maintenance activities for the Segment are available for a minimum of 30 individual Components of the Segment.
3. Document the maintenance program activities and results for each Segment, including maintenance dates and Countable Events for each included Component.
4. Analyze the maintenance program activities and results for each Segment to determine the overall performance of the Segment and develop maintenance intervals.
5. Determine the maximum allowable maintenance interval for each Segment such that the Segment experiences **Countable Events** on no more than 4% of the Components within the Segment, for the greater of either the last 30 Components maintained or all Components maintained in the previous year.

To maintain the technical justification for the ongoing use of a performance-based PSMP:

1. At least annually, update the list of Components and Segments and/or description if any changes occur within the Segment.
2. Perform maintenance on the greater of 5% of the Components (addressed in the performance based PSMP) in each Segment or 3 individual Components within the Segment in each year.
3. For the prior year, analyze the maintenance program activities and results for each Segment to determine the overall performance of the Segment.
4. Using the prior year's data, determine the maximum allowable maintenance interval for each Segment such that the Segment experiences Countable Events on no more than 4% of the Components within the Segment, for the greater of either the last 30 Components maintained or all Components maintained in the previous year.

If the Components in a Segment maintained through a performance-based PSMP experience 4% or more Countable Events, develop, document, and implement an action plan to reduce the Countable Events to less than 4% of the Segment population within 3 years.

Implementation Plan

Project 2014-01 Standards Applicability for Dispersed Power Producing Resources PRC-005-X(X)

The standard numbers currently include an (X) to indicate the version numbering will be updated. Some standards are open in current projects and others are pending with governmental authorities. As a result, NERC will assign the appropriate version number prior to BOT adoption.

Standards Involved

Approval:

- PRC-005-X(X) – Protection System, Automatic Reclosing, and Sudden Pressure Relaying Maintenance

Retirement:

- PRC-005-3(X) – Protection System and Automatic Reclosing Maintenance
- PRC-005-X – Protection System, Automatic Reclosing, and Sudden Pressure Relaying Maintenance

Prerequisite Approvals:

N/A

Background:

In light of the adoption of a revised “Bulk Electric System” definition by the Board of Trustees, changes to the applicability sections of certain Reliability Standards, including PRC-005, are necessary to align with the implementation of the revised “Bulk Electric System” definition. The Standard Drafting Team (SDT) for Project 2014-01 – Standards Applicability for Dispersed Power Producing Resources has modified the applicability section of certain Generator Owner/Generator Operator requirements to recognize the unique technical and reliability aspects of dispersed generation in order to ensure the applicability of the standards is consistent with the reliable operation of the Bulk-Power System.

Reliability Standard PRC-005-X has concluded a 45-day comment and ballot period to address sudden pressure relays. The SDT has revised the applicability section of PRC-005-X to align with the revised definition of “Bulk Electric System” in the event that this version of PRC-005 is mandatory and enforceable on the effective date of the revised definition of “Bulk Electric System.”

General Considerations:

PRC-005-X(X) is proposed for approval to align the applicability section of PRC-005-X with the revised definition of “Bulk Electric System.” PRC-005-X may already be retired pursuant to an Implementation

Plan of a successor version of PRC-005 by the time the revised definition of “Bulk Electric System” becomes effective. If this occurs, PRC-005-X(X) will not go into effect.

Effective Date

PRC-005-X(X) shall become effective on the later of the effective date of the revised definition of Bulk Electric System or the first day following the effective date of PRC-005-X.

Retirement of Existing Standards

PRC-005-X shall be retired at midnight of the day immediately prior to the effective date of PRC-005-X(X) in the particular jurisdiction in which the revised standard is becoming effective.

Implementation Plan

PRC-005-X(X) only modifies the applicability for PRC-005-X. All aspects of the Implementation Plan for PRC-005-X will remain applicable to PRC-005-X(X) and are incorporated here by reference.

Cross References

The Implementation Plan for the revised definition of “Bulk Electric System” is available [here](#).¹

The Implementation Plan for PRC-005-X is available [here](#).²

1

2

Unofficial Comment Form

Project 2014-01 Standards Applicability for Dispersed Generation Resources

Please **DO NOT** use this form for submitting comments. Please use the [electronic form](#) to submit comments on the Standards. The electronic comment form must be completed by **July 28, 2014**.

If you have questions please contact [Sean Cavote](#) or by telephone at 404.446.9697.

All documents for this project are available on the [project page](#).

Background Information

This posting solicits formal comments on two of three Project 2014-01 Dispersed Generation Resources (DGR) “high-priority” Reliability Standards as identified in the draft white paper (White Paper) prepared by the Project 2014-01 (Project) drafting team (DGR SDT).

The goal of the Project is to ensure that the Generator Owners (GOs) and Generator Operators (GOPs) of dispersed power producing resources are appropriately assigned responsibility for requirements that impact the reliability of the Bulk Power System, as the characteristics of operating dispersed power producing resources can be unique. In light of the revised Bulk Electric System (BES) definition approved by the Federal Energy Regulatory Commission in 2014, the intent of this Project is generally to maintain the status quo for applicability of the standards as they have been applied over time with respect to dispersed power producing resources where the status quo does not create a reliability gap.

The DGR SDT performed a review of all standards that apply to GOs and GOPs and categorized how each standard should be applied to dispersed power producing resources to accomplish the reliability purpose of the standard. The DGR SDT developed the White Paper to explain its approach, which was posted on April 17, 2014 for an informal comment period.¹ The industry feedback received on the White Paper allowed the DGR SDT to refine its approach and finalize recommended revisions to the standards. As part of this review the DGR SDT determined that there are three high-priority standards in which immediate attention is required to provide direction to industry stakeholders as soon as feasible regarding how to appropriately direct compliance related preparations:

- PRC-004-2.1a;²
- PRC-005; and
- VAR-002.

¹ The current version of the White Paper can be downloaded on the Project web page at <http://www.nerc.com/pa/Stand/Pages/Project-2014-01-Standards-Applicability-for-Dispersed-Generation-Resources.aspx>.

² The DGR SDT has prepared applicability revisions for relevant versions of PRC-004 – the third high-priority standard – which will be posted for ballot and comment separately after the current comment period and ballot of that standard in Project 2010-05.1 ends.

Because each of the “high-priority” standards has recently been revised or is undergoing revision in another current project, the DGR SDT has developed revisions to multiple versions of each standard to allow for different possibilities in the timing of regulatory approvals. When the revisions are being applied to a version that is not the last approved version of the standard or to a version that is pending regulatory approval, the version is noted with “(X)” after it. For example, this posting includes PRC-005-2(X), which proposes applicability changes to PRC-005-2, as well as PRC-005-3(X), which proposes applicability changes to PRC-005-3. Please note that any versions of the standards posted under this project with an “X” suffix will have a version number applied at a later time in order to manage sequencing of version numbers. The intent of balloting the recommended applicability revisions separately from the technical changes that are ongoing in other projects is to provide flexibility to allow approved applicability revisions to move forward on an expedited timeline as needed to support implementation of the revised definition of BES.

The DGR SDT responded to industry comments as contained in its Consideration of Comments, which is included with this posting, along with the DGR SDT’s response to comments on the original Standards Authorization Request (SAR) that defines the scope of this Project.

The DGR SDT continues to coordinate with other NERC Reliability Standards projects currently under development to ensure continuity and to develop a posting strategy that ensures all applicability changes approved by ballot are filed and implemented as quickly as possible without adversely impacting other projects. The DGR SDT Coordination Plan included with this posting details that coordination.

Summary of Proposed Changes

The DGR’s recommended changes are limited to revising the applicability of the relevant versions of PRC-005 and VAR-002 to appropriately exclude certain dispersed power producing resources from the standards. Although the redlined versions of the standards included with this posting contain changes that appear structurally different, the substance of the changes in each respective set of standards is the same.

The drafting team has posted the following standards, along with corresponding implementation plans:

- PRC-005-2(X) (clean and redlined against PRC-005-2)
 - PRC-005-3(X) (clean and redlined against PRC-005-3, which is pending regulatory approval)
 - PRC-005-X(X) (clean and redlined against the latest draft of PRC-005-X from Project 2007-17.1)
 - VAR-002-2b(X) (clean and redlined against currently enforceable VAR-002-2b)
 - VAR-002-4 (clean and redlined against VAR-002-3, which is pending regulatory approval)
- In addition, the drafting team has posted the following supporting documents.
- SAR

- White Paper³
- DGR SDT Response to SAR Comments
- DGR SDT Response to White Paper Comments
- Draft DGR SDT Coordination Plan

Please note that the DGR SDT has not revised the Violation Risk Factors (VRFs) or Violation Severity Levels (VSLs) associated with the subject standards because the proposed revisions do not change the reliability intent or impact of any of the requirements. If the applicability recommendations are approved by industry, the DGR SDT's intent is that the VRFs and VSLs for each requirement would be unchanged from those either previously approved (for currently enforceable versions of standards or those pending regulatory approval) or would be developed by the drafting team responsible for revising technical content (for those versions of standards currently in development in another standards project).

You do not have to answer all questions. Enter comments in simple text format. Bullets, numbers, and special formatting will not be retained.

Questions

1. Do you agree with the revisions made in proposed PRC-005-2(X) to clarify applicability of PRC-005-2 to dispersed power producing resources included in the BES through Inclusion I4 of the BES definition? If not, please provide technical rationale for your disagreement along with suggested language changes.

Yes:

No:

Comments:

2. Do you agree with the revisions made in proposed PRC-005-3(X) to clarify applicability of PRC-005-3 to dispersed power producing resources included in the BES through Inclusion I4 of the BES definition? If not, please provide technical rationale for your disagreement along with suggested language changes.

Yes:

No:

Comments:

3. Do you agree with the revisions made in proposed PRC-005-X(X) to clarify applicability of PRC-005-X (the version of PRC-005 containing revisions to address Sudden Pressure relays, being developed in

³ Please note that the DGR SDT is currently revising the White Paper and will post the next version when it is finalized. However, the DGR SDT's response to White Paper comments identifies areas of the White Paper the DGR SDT intends to clarify.

Project 2007-17.1) to dispersed power-producing resources included in the BES through Inclusion I4 of the BES definition? If not, please provide technical rationale for your disagreement along with suggested language changes.

Yes:

No:

Comments:

4. Do you agree with the revisions made in proposed VAR-002-2b(X) to clarify applicability of VAR-002-2b to dispersed power producing resources included in the BES through Inclusion I4 of the BES definition? If not, please provide technical rationale for your disagreement along with suggested language changes.

Yes:

No:

Comments:

5. Do you agree with the revisions made in proposed VAR-002-4 to clarify applicability of VAR-002-3 to dispersed power producing resources included in the BES through Inclusion I4 of the BES definition? If not, please provide technical rationale for your disagreement along with suggested language changes.

Yes:

No:

Comments:

6. Do you have any additional comments to assist the DGR SDT in further developing its recommendations?

Yes:

No:

Comments:

Project 2014-01 Dispersed Generation Resources

DRAFT Plan for Standards Drafting Team (SDT) Coordination and Balloting Multiple Versions of Standards | June 12, 2014

Background

Pursuant to the Standards Authorization Request for this project posted on November 20, 2014, the Project 2014-01 Dispersed Generation Resources (DGR) SDT proposes to modify PRC-004-2.1a, PRC-004-3, PRC-005-2, PRC-005-3, PRC-005-X, VAR-002-2b, and VAR-002-3 to account for the unique characteristics of dispersed power producing resources. As the DGR SDT has explained in the White Paper it has developed, the DGR SDT has classified each of these standards as high-priority standards requiring applicability changes as soon as practicable.

Because each of the high-priority standards has recently been revised or is undergoing revision in another active standard development project, the DGR SDT has developed revisions to multiple versions of each standard to allow for different possibilities in the timing of regulatory approvals. Specifically, two of the three standards identified by the DGR SDT as high priority (PRC-004 and PRC-005) are being revised by other projects. NERC and the DGR SDT recognize that developing multiple versions of the same standard in different projects may be confusing; however, developing and balloting the recommended DGR applicability revisions separately from the technical changes that are ongoing in other active standard development projects provides flexibility in effectuating applicability revisions on an expedited timeline as needed to support implementation of the revised definition of the Bulk Electric System. The DGR project is being carefully coordinated with other active standard development projects with careful consideration of the period of time various versions of each standard may be in effect.

When DGR revisions are applied to a standard version that is not the last approved version of the standard or to a standard version that may be superseded by another version in active standard development outside the DGR project, the version is noted with "(X)" after it. For example, the DGR SDT is developing PRC-005-2(X), which proposes applicability changes to PRC-005-2, as well as PRC-005-3(X), which proposes applicability changes to PRC-005-3. Please note that NERC will apply at a later time the appropriate version numbers to standard versions containing an "X" suffix in order to effectively manage sequencing of version numbers in these projects.

PRC-004 DGR Applicability Modifications

(Note that since PRC-004-3 is posted for a 45-day comment period and additional ballot through June 30, 2014, NERC is deferring posting DGR applicability recommendations on PRC-004 until after that ballot closes.)

PRC-004-2.1a (Analysis and Mitigation of Transmission and Generation Protection System Misoperations) is FERC-approved and has been enforceable since November 25, 2013. PRC-004-3 is in active standard development in Project 2010-05.1 and may supersede PRC-004-2.1a; however, until PRC-004-3 is completed, approved by applicable government authorities, and becomes enforceable, there may be a need for revisions to tailor the applicability of PRC-004-2.1a, which the DGR SDT intends to ballot as PRC-004-2.1a(X). The proposed implementation period for PRC-004-3 is 12 months.

PRC-004-3 (Analysis and Mitigation of Transmission and Generation Protection System Misoperations) is currently in active standard development in Project 2010-05.1 Protection System Misoperations. The DGR SDT and the Protection System Misoperations SDT are coordinating regarding changes to the applicability of PRC-004. The DGR

SDT intends to ballot proposed applicability revisions to PRC-004-3 as PRC-004-3(X). Depending on the timing of completion of Project 2010-05.1 relative to Project 2014-01, both PRC-004-2.1a(X) and PRC-004-3(X) may be needed.

PRC-005 DGR Applicability Modifications

PRC-005-2 (Protection System Maintenance): PRC-005-2 is FERC-approved and will become enforceable on April 1, 2015. PRC-005-2 has a 12-year phased-in implementation period and may be enforceable for a period of time before PRC-005-3 becomes enforceable after approval by the applicable government authorities. Therefore, the DGR SDT is balloting proposed revisions to the applicability of PRC-005-2 as PRC-005-2(X).

PRC-005-3 (Protection System and Automatic Reclosing Maintenance): PRC-005-3 was adopted by the NERC Board of Trustees (Board) on November 7, 2013 and filed with the applicable governmental authorities on February 14, 2014. Upon regulatory approval, PRC-005-3 will supersede PRC-005-2, and according to its proposed implementation plan, will continue the 12-year implementation period for components included in PRC-005-2. Therefore, the DGR SDT is balloting proposed revisions to the applicability of PRC-005-3 as PRC-005-3(X).

PRC-005-X (Protection System, Automatic Reclosing, and Sudden Pressure Relaying Maintenance): PRC-005-X is currently in an active standards development project. A ballot for PRC-005-X concluded on June 3, 2014 but did not receive sufficient affirmative votes for approval. The PRC-005-X SDT will consider comments and, if needed, make revisions to the standard. Language to clarify the applicability of the requirements of PRC-005-X was agreed to by both SDTs, and is being balloted in the DGR project as PRC-005-X(X). Depending on the timing of the completion of the DGR project relative to Project 2007-17.3, NERC will determine the appropriate approach to filing applicability changes approved by balloters and adopted by the Board.

VAR-002 DGR Applicability Modifications

VAR-002-2b (Generator Operation for Maintaining Network Voltage Schedules) is FERC-approved and has been enforceable since July 1, 2013. A successor version, VAR-002-3, is pending regulatory approval and has a proposed implementation period of one quarter. Depending on the time of regulatory approvals of VAR-002-3, VAR-002-2b may remain in effect. Therefore, the DGR SDT is balloting proposed revisions to clarify the applicability of VAR-002-2b as VAR-002-2b(X).

VAR-002-3 (Generator Operation for Maintaining Network Voltage Schedules) was adopted by the Board on May 7, 2014 and filed with the applicable governmental authorities on June 10, 2014. No other version of VAR-002 is in active standard development outside the DGR project. Therefore, the DGR SDT is balloting proposed revisions to VAR-002-3 as VAR-002-4.

Standards Announcement **Reminder**

Project 2014-01 Applicability for Dispersed Generation
Resources Standards

PRC-005-2(X), PRC-005-3(X), PRC-005-X(X),
VAR-002-2b(X), VAR-002-4

Ballots Now Open through July 28, 2014

[Now Available](#)

Ballots for five **Project 2014-01 Dispersed Generation Resources Reliability Standards, (PRC-005-2(X), PRC-005-3(X), PRC-005-X(X), VAR-002-2b(X), and VAR-002-4)** are open through **8 p.m. Eastern on Monday, July 28, 2014.**

If you have questions please contact [Sean Cavote](#) (via email) or by telephone at (404) 446-9697.

Background information for this project can be found on the [project page](#).

Instructions for Balloting

Members of the ballot pools associated with this project may log in and submit their votes for the standards by clicking [here](#).

Next Steps

The ballot results will be announced and posted on the project page. The drafting team will consider all comments received during the formal comment period and, if needed, make revisions to the standards and post them for an additional ballot. If the comments do not show the need for significant revisions, the standards will proceed to a final ballot.

For information on the **Standards Development Process**, please refer to the [Standard Processes Manual](#).

*For more information or assistance, please contact [Wendy Muller](#),
Standards Development Administrator, or at 404-446-2560.*

North American Electric Reliability Corporation
3353 Peachtree Rd, NE
Suite 600, North Tower
Atlanta, GA 30326
404-446-2560 | www.nerc.com

Standards Announcement

Project 2014-01 Standards Applicability for Dispersed Generation Resources

Formal Comment Period Now Open through July 28, 2014
Ballot Pools Forming Now through July 11, 2014

[Now Available](#)

A 45-day posting to solicit formal comments on two of three Project 2014-01 Dispersed Generation Resources “high-priority” Reliability Standards as identified in the draft white paper prepared by the Project 2014-01 drafting team is open through **8 p.m. Eastern on Monday, July 28, 2014.**

If you have questions please contact [Sean Cavote](#) (via email) or by telephone at (404) 446-9697.

Background information for this project can be found on the [project page](#).

Instructions for Commenting

Please use the [electronic form](#) to submit comments on the standards and implementation plans. If you experience any difficulties in using the electronic form, please contact [Wendy Muller](#). An off-line, unofficial copy of the comment form is posted on the [project page](#).

Instructions for Joining Ballot Pools

Ballot pools are currently being formed. Registered Ballot Body members must join the ballot pools to be eligible to cast ballots. Registered Ballot Body members may join the ballot pools at the following page: [Join Ballot Pool](#)

During the pre-ballot window, members of the ballot pools may communicate with one another by using their “ballot pool list servers.” (Once the balloting begins, ballot pool members are prohibited from using the ballot pool list servers.) The list servers for this project are:

[bp-2014-01_PRC-005-2\(X\)_in@nerc.com](mailto:bp-2014-01_PRC-005-2(X)_in@nerc.com)

[bp-2014-01_PRC-005-3\(X\)_in@nerc.com](mailto:bp-2014-01_PRC-005-3(X)_in@nerc.com)

[bp-2014-01_PRC-005-X\(X\)_in@nerc.com](mailto:bp-2014-01_PRC-005-X(X)_in@nerc.com)

bp-2014-01_VAR-002-4_in@nerc.com

[bp-2014-01_VAR-002-2b\(X\)_in@nerc.com](mailto:bp-2014-01_VAR-002-2b(X)_in@nerc.com)

bp-PRC005_VAR002_DGR_IP_in@nerc.com

Next Steps

A ballot period for the standards and implementation plans will be conducted **July 18-28, 2014**.

For information on the **Standards Development Process**, please refer to the [Standard Processes Manual](#).

*For more information or assistance, please contact [Wendy Muller](#),
Standards Development Administrator, or at 404-446-2560.*

North American Electric Reliability Corporation
3353 Peachtree Rd, NE
Suite 600, North Tower
Atlanta, GA 30326
404-446-2560 | www.nerc.com

Standards Announcement

Project 2014-01 Standards Applicability for Dispersed Generation Resources

Formal Comment Period Now Open through July 28, 2014
Ballot Pools Forming Now through July 11, 2014

[Now Available](#)

A 45-day posting to solicit formal comments on two of three Project 2014-01 Dispersed Generation Resources “high-priority” Reliability Standards as identified in the draft white paper prepared by the Project 2014-01 drafting team is open through **8 p.m. Eastern on Monday, July 28, 2014.**

If you have questions please contact [Sean Cavote](#) (via email) or by telephone at (404) 446-9697.

Background information for this project can be found on the [project page](#).

Instructions for Commenting

Please use the [electronic form](#) to submit comments on the standards and implementation plans. If you experience any difficulties in using the electronic form, please contact [Wendy Muller](#). An off-line, unofficial copy of the comment form is posted on the [project page](#).

Instructions for Joining Ballot Pools

Ballot pools are currently being formed. Registered Ballot Body members must join the ballot pools to be eligible to cast ballots. Registered Ballot Body members may join the ballot pools at the following page: [Join Ballot Pool](#)

During the pre-ballot window, members of the ballot pools may communicate with one another by using their “ballot pool list servers.” (Once the balloting begins, ballot pool members are prohibited from using the ballot pool list servers.) The list servers for this project are:

[bp-2014-01_PRC-005-2\(X\)_in@nerc.com](mailto:bp-2014-01_PRC-005-2(X)_in@nerc.com)

[bp-2014-01_PRC-005-3\(X\)_in@nerc.com](mailto:bp-2014-01_PRC-005-3(X)_in@nerc.com)

[bp-2014-01_PRC-005-X\(X\)_in@nerc.com](mailto:bp-2014-01_PRC-005-X(X)_in@nerc.com)

bp-2014-01_VAR-002-4_in@nerc.com

[bp-2014-01_VAR-002-2b\(X\)_in@nerc.com](mailto:bp-2014-01_VAR-002-2b(X)_in@nerc.com)

bp-PRC005_VAR002_DGR_IP_in@nerc.com

Next Steps

A ballot period for the standards and implementation plans will be conducted **July 18-28, 2014**.

For information on the **Standards Development Process**, please refer to the [Standard Processes Manual](#).

*For more information or assistance, please contact [Wendy Muller](#),
Standards Development Administrator, or at 404-446-2560.*

North American Electric Reliability Corporation
3353 Peachtree Rd, NE
Suite 600, North Tower
Atlanta, GA 30326
404-446-2560 | www.nerc.com

Standards Announcement

Project 2014-01 Standards Applicability for Dispersed Generation Resources

Formal Comment Period Now Open through July 28, 2014
Ballot Pools Forming Now through July 11, 2014

[Now Available](#)

A 45-day posting to solicit formal comments on two of three Project 2014-01 Dispersed Generation Resources “high-priority” Reliability Standards as identified in the draft white paper prepared by the Project 2014-01 drafting team is open through **8 p.m. Eastern on Monday, July 28, 2014.**

If you have questions please contact [Sean Cavote](#) (via email) or by telephone at (404) 446-9697.

Background information for this project can be found on the [project page](#).

Instructions for Commenting

Please use the [electronic form](#) to submit comments on the standards and implementation plans. If you experience any difficulties in using the electronic form, please contact [Wendy Muller](#). An off-line, unofficial copy of the comment form is posted on the [project page](#).

Instructions for Joining Ballot Pools

Ballot pools are currently being formed. Registered Ballot Body members must join the ballot pools to be eligible to cast ballots. Registered Ballot Body members may join the ballot pools at the following page: [Join Ballot Pool](#)

During the pre-ballot window, members of the ballot pools may communicate with one another by using their “ballot pool list servers.” (Once the balloting begins, ballot pool members are prohibited from using the ballot pool list servers.) The list servers for this project are:

[bp-2014-01_PRC-005-2\(X\)_in@nerc.com](mailto:bp-2014-01_PRC-005-2(X)_in@nerc.com)

[bp-2014-01_PRC-005-3\(X\)_in@nerc.com](mailto:bp-2014-01_PRC-005-3(X)_in@nerc.com)

[bp-2014-01_PRC-005-X\(X\)_in@nerc.com](mailto:bp-2014-01_PRC-005-X(X)_in@nerc.com)

bp-2014-01_VAR-002-4_in@nerc.com

[bp-2014-01_VAR-002-2b\(X\)_in@nerc.com](mailto:bp-2014-01_VAR-002-2b(X)_in@nerc.com)

bp-PRC005_VAR002_DGR_IP_in@nerc.com

Next Steps

A ballot period for the standards and implementation plans will be conducted **July 18-28, 2014**.

For information on the **Standards Development Process**, please refer to the [Standard Processes Manual](#).

*For more information or assistance, please contact [Wendy Muller](#),
Standards Development Administrator, or at 404-446-2560.*

North American Electric Reliability Corporation
3353 Peachtree Rd, NE
Suite 600, North Tower
Atlanta, GA 30326
404-446-2560 | www.nerc.com

Standards Announcement

Project 2014-01 Applicability for Dispersed Resources Standards

Ballot Results

[Now Available](#)

Ballots for five **Project 2014-01 Dispersed Generation Resources Reliability Standards, (PRC-005-2(X), PRC-005-3(X), PRC-005-X(X), VAR-002-2b(X), and VAR-002-4)** concluded at **8 p.m. Eastern on Tuesday, July 29, 2014.**

The standards achieved a quorum and received sufficient affirmative votes for approval. Voting statistics are listed below, and the [Ballot Results](#) page provides a link to the detailed results for the ballot.

	Ballot Results
	Quorum /Approval
PRC-005-2(X)	79.49% / 91.38%
PRC-005-3(X)	80.15% / 92.20%
PRC-005-X(X)	80.00% / 89.51%
VAR-002-2b(X)	80.83% / 90.58%
VAR-002-4	80.36% / 87.09%

Background information for this project can be found on the [project page](#).

Next Steps

The drafting team will consider all comments received during the formal comment period and, if needed, make revisions to the standards and post them for an additional ballot. If the comments do not show the need for significant revisions, the standards will proceed to a final ballot.

For more information on the **Standards Development Process**, please refer to the [Standard Processes Manual](#).

*For more information or assistance, please contact [Wendy Muller](#),
Standards Development Administrator, or at 404-446-2560.*

North American Electric Reliability Corporation
3353 Peachtree Rd, NE
Suite 600, North Tower
Atlanta, GA 30326
404-446-2560 | www.nerc.com

Log In

- Ballot Pools
- Current Ballots
- Ballot Results
- Registered Ballot Body
- Proxy Voters
- Register

[Home Page](#)

Ballot Results	
Ballot Name:	Project 2014-01 PRC-005-X(X)
Ballot Period:	7/18/2014 - 7/29/2014
Ballot Type:	Initial
Total # Votes:	316
Total Ballot Pool:	395
Quorum:	80.00 % The Quorum has been reached
Weighted Segment Vote:	89.51 %
Ballot Results:	The ballot has closed

Summary of Ballot Results										
Segment	Ballot Pool	Segment Weight	Affirmative		Negative		Negative Vote without a Comment	Abstain	No Vote	
			# Votes	Fraction	# Votes	Fraction				
1 - Segment 1	105	1	62	0.925	5	0.075	0	19	19	
2 - Segment 2	8	0.5	2	0.2	3	0.3	0	1	2	
3 - Segment 3	89	1	54	0.931	4	0.069	0	15	16	
4 - Segment 4	29	1	16	0.941	1	0.059	0	5	7	
5 - Segment 5	93	1	51	0.895	6	0.105	0	14	22	
6 - Segment 6	54	1	34	0.895	4	0.105	0	7	9	
7 - Segment 7	3	0.1	1	0.1	0	0	0	0	2	
8 - Segment 8	4	0.4	4	0.4	0	0	0	0	0	
9 - Segment 9	2	0.1	1	0.1	0	0	0	0	1	

10 - Segment 10	8	0.7	7	0.7	0	0	0	0	1
Totals	395	6.8	232	6.087	23	0.713	0	61	79

Individual Ballot Pool Results				
Segment	Organization	Member	Ballot	NERC Notes
1	Ameren Services	Eric Scott	Affirmative	
1	American Electric Power	Paul B Johnson	Affirmative	
1	Arizona Public Service Co.	Brian Cole	Affirmative	
1	Associated Electric Cooperative, Inc.	John Bussman	Affirmative	
1	Austin Energy	James Armke	Affirmative	
1	Avista Utilities	Heather Rosentrater	Abstain	
1	Balancing Authority of Northern California	Kevin Smith	Affirmative	
1	Baltimore Gas & Electric Company	Christopher J Scanlon	Affirmative	
1	Basin Electric Power Cooperative	David Rudolph		
1	BC Hydro and Power Authority	Patricia Robertson	Abstain	
1	Beaches Energy Services	Don Cuevas	Affirmative	
1	Black Hills Corp	Wes Wingen	Abstain	
1	Bonneville Power Administration	Donald S. Watkins	Affirmative	
1	Bryan Texas Utilities	John C Fontenot	Affirmative	
1	CenterPoint Energy Houston Electric, LLC	John Brockhan	Affirmative	
1	Central Electric Power Cooperative	Michael B Bax	Affirmative	
1	Central Iowa Power Cooperative	Kevin J Lyons	Affirmative	
1	Central Maine Power Company	Joseph Turano Jr.	Affirmative	
1	City of Tallahassee	Daniel S Langston	Abstain	
1	Clark Public Utilities	Jack Stamper	Affirmative	
1	Colorado Springs Utilities	Shawna Speer	Negative	SUPPORTS THIRD PARTY COMMENTS - (PSEG) - (Colorado Springs Utilities)
1	Consolidated Edison Co. of New York	Christopher L de Graffenried	Affirmative	
1	Dairyland Power Coop.	Robert W. Roddy	Affirmative	
1	Dayton Power & Light Co.	Hertzel Shamash		
1	Dominion Virginia Power	Larry Nash	Negative	SUPPORTS THIRD PARTY COMMENTS - (Dominion's)
1	Duke Energy Carolina	Doug E Hils	Affirmative	
1	Empire District Electric Co.	Ralph F Meyer		
1	Encari	Steven E Hamburg		
1	Entergy Transmission	Oliver A Burke	Abstain	
1	FirstEnergy Corp.	William J Smith	Abstain	
1	Florida Keys Electric Cooperative Assoc.	Dennis Minton	Affirmative	
1	Florida Power & Light Co.	Mike O'Neil	Affirmative	
1	Gainesville Regional Utilities	Richard Bachmeier	Affirmative	
1	Georgia Transmission Corporation	Jason Snodgrass	Affirmative	
1	Great River Energy	Gordon Pietsch	Affirmative	
1	Hydro One Networks, Inc.	Muhammed Ali	Affirmative	
1	Hydro-Quebec TransEnergie	Martin Boisvert	Abstain	
1	Idaho Power Company	Molly Devine	Negative	COMMENT RECEIVED
1	International Transmission Company Holdings Corp	Michael Moltane	Negative	COMMENT RECEIVED
1	JDRJC Associates	Jim D Cyrulewski	Abstain	
1	JEA	Ted E Hobson		
1	KAMO Electric Cooperative	Walter Kenyon		
1	Kansas City Power & Light Co.	Daniel Gibson	Affirmative	
1	Keys Energy Services	Stanley T Rzad	Affirmative	
1	Lakeland Electric	Larry E Watt	Affirmative	
1	Lincoln Electric System	Doug Bantam	Abstain	
1	Long Island Power Authority	Robert Ganley		
1	Lower Colorado River Authority	Martyn Turner	Affirmative	

1	M & A Electric Power Cooperative	William Price	Affirmative	
1	Manitoba Hydro	Jo-Anne M Ross	Affirmative	
1	MEAG Power	Danny Dees	Affirmative	
1	MidAmerican Energy Co.	Terry Harbour	Affirmative	
1	Minnkota Power Coop. Inc.	Daniel L Inman	Affirmative	
1	Muscatine Power & Water	Andrew J Kurriger	Affirmative	
1	N.W. Electric Power Cooperative, Inc.	Mark Ramsey	Affirmative	
1	National Grid USA	Michael Jones	Affirmative	
1	NB Power Corporation	Alan MacNaughton	Abstain	
1	Nebraska Public Power District	Jamison Cawley	Abstain	
1	New York Power Authority	Bruce Metruck	Affirmative	
1	Northeast Missouri Electric Power Cooperative	Kevin White	Affirmative	
1	Northeast Utilities	William Temple	Affirmative	
1	Northern Indiana Public Service Co.	Julaine Dyke	Abstain	
1	Ohio Valley Electric Corp.	Scott R Cunningham		
1	Oklahoma Gas and Electric Co.	Terri Pyle	Affirmative	
1	Omaha Public Power District	Doug Peterchuck	Affirmative	
1	Oncor Electric Delivery	Jen Fiegel	Abstain	
1	Orlando Utilities Commission	Brad Chase	Affirmative	
1	Otter Tail Power Company	Daryl Hanson		
1	Pacific Gas and Electric Company	Bangalore Vijayraghavan		
1	Platte River Power Authority	John C. Collins	Affirmative	
1	Portland General Electric Co.	John T Walker	Affirmative	
1	Potomac Electric Power Co.	David Thorne	Abstain	
1	PPL Electric Utilities Corp.	Brenda L Truhe	Abstain	
1	Public Service Company of New Mexico	Laurie Williams		
1	Public Service Electric and Gas Co.	Kenneth D. Brown		
1	Public Utility District No. 1 of Okanogan County	Dale Dunckel		
1	Puget Sound Energy, Inc.	Denise M Lietz	Affirmative	
1	Rochester Gas and Electric Corp.	John C. Allen	Affirmative	
1	Sacramento Municipal Utility District	Tim Kelley	Affirmative	
1	Salt River Project	Robert Kondziolka	Negative	SUPPORTS THIRD PARTY COMMENTS - (Salt River Project)
1	San Diego Gas & Electric	Will Speer	Abstain	
1	SaskPower	Wayne Guttormson		
1	Seattle City Light	Pawel Krupa	Affirmative	
1	Seminole Electric Cooperative, Inc.	Glenn Spurlock		
1	Sho-Me Power Electric Cooperative	Denise Stevens	Affirmative	
1	Snohomish County PUD No. 1	Long T Duong	Affirmative	
1	South Carolina Electric & Gas Co.	Tom Hanzlik	Affirmative	
1	South Carolina Public Service Authority	Shawn T Abrams	Affirmative	
1	Southern California Edison Company	Steven Mavis	Affirmative	
1	Southern Company Services, Inc.	Robert A. Schaffeld	Affirmative	
1	Southern Illinois Power Coop.	William Hutchison	Affirmative	
1	Southwest Transmission Cooperative, Inc.	John Shaver	Affirmative	
1	Sunflower Electric Power Corporation	Noman Lee Williams	Affirmative	
1	Tacoma Power	John Merrell	Abstain	
1	Tampa Electric Co.	Beth Young		
1	Tennessee Valley Authority	Howell D Scott	Abstain	
1	Trans Bay Cable LLC	Steven Powell	Affirmative	
1	Tri-State Generation & Transmission Association, Inc.	Tracy Sliman	Affirmative	
1	Tucson Electric Power Co.	John Tolo		
1	U.S. Bureau of Reclamation	Richard T Jackson	Abstain	
1	United Illuminating Co.	Jonathan Appelbaum	Affirmative	
1	Westar Energy	Allen Klassen	Affirmative	
1	Western Area Power Administration	Lloyd A Linke		
1	Wolverine Power Supply Coop., Inc.	Michelle Clements		
1	Xcel Energy, Inc.	Gregory L Pieper	Affirmative	
2	BC Hydro	Venkataramakrishnan Vinnakota		
2	California ISO	Rich Vine	Affirmative	
2	Electric Reliability Council of Texas, Inc.	Cheryl Moseley	Negative	SUPPORTS THIRD PARTY COMMENTS -

				(IRC SRC)
2	ISO New England, Inc.	Matthew F Goldberg	Negative	COMMENT RECEIVED
2	MISO	Marie Knox	Negative	SUPPORTS THIRD PARTY COMMENTS - (ISO/RTO SRC)
2	New York Independent System Operator	Gregory Campoli		
2	PJM Interconnection, L.L.C.	stephanie monzon	Abstain	
2	Southwest Power Pool, Inc.	Charles H. Yeung	Affirmative	
3	AEP	Michael E Deloach	Affirmative	
3	Alabama Power Company	Robert S Moore	Affirmative	
3	Ameren Corp.	David J Jendras	Affirmative	
3	APS	Sarah Kist	Affirmative	
3	Associated Electric Cooperative, Inc.	Todd Bennett	Affirmative	
3	Atlantic City Electric Company	NICOLE BUCKMAN	Abstain	
3	Avista Corp.	Scott J Kinney	Abstain	
3	Basin Electric Power Cooperative	Jeremy Voll	Affirmative	
3	BC Hydro and Power Authority	Pat G. Harrington	Abstain	
3	Blue Ridge Electric	James L Layton		
3	Bonneville Power Administration	Rebecca Berdahl	Affirmative	
3	Central Electric Power Cooperative	Adam M Weber	Affirmative	
3	City of Anaheim Public Utilities Department	Dennis M Schmidt		
3	City of Austin dba Austin Energy	Andrew Gallo	Affirmative	
3	City of Clewiston	Lynne Mila	Affirmative	
3	City of Farmington	Linda R Jacobson	Abstain	
3	City of Green Cove Springs	Mark Schultz	Affirmative	
3	City of Redding	Bill Hughes	Affirmative	
3	City of Tallahassee	Bill R Fowler	Abstain	
3	Cleco Corporation	Michelle A Corley	Affirmative	
3	Colorado Springs Utilities	Jean Mueller	Negative	SUPPORTS THIRD PARTY COMMENTS - (PSEG) - (Kaleb Brimhall)
3	ComEd	John Bee	Affirmative	
3	Consolidated Edison Co. of New York	Peter T Yost	Affirmative	
3	Consumers Energy Company	Gerald G Farringer	Affirmative	
3	Cowlitz County PUD	Russell A Noble	Affirmative	
3	CPS Energy	Jose Escamilla		
3	Delmarva Power & Light Co.	Michael R. Mayer	Abstain	
3	Dominion Resources, Inc.	Connie B Lowe	Negative	SUPPORTS THIRD PARTY COMMENTS - (See Dominion's submitted comments)
3	DTE Electric	Kent Kujala	Affirmative	
3	FirstEnergy Corp.	Cindy E Stewart	Abstain	
3	Florida Keys Electric Cooperative	Tom B Anthony	Affirmative	
3	Florida Municipal Power Agency	Joe McKinney	Affirmative	
3	Florida Power & Light Co.	Summer C. Esquerre	Affirmative	
3	Florida Power Corporation	Lee Schuster	Affirmative	
3	Fort Pierce Utilities Authority	Thomas Parker		
3	Gainesville Regional Utilities	Kenneth Simmons	Affirmative	
3	Georgia System Operations Corporation	Scott McGough	Affirmative	
3	Great River Energy	Brian Glover	Affirmative	
3	Hydro One Networks, Inc.	Ayesha Sabouba	Affirmative	
3	Imperial Irrigation District	Jesus S. Alcaraz		
3	JEA	Garry Baker		
3	KAMO Electric Cooperative	Theodore J Hilmes		
3	Kansas City Power & Light Co.	Joshua D Bach	Affirmative	
3	Kissimmee Utility Authority	Gregory D Woessner	Affirmative	
3	Lakeland Electric	Mace D Hunter		
3	Lincoln Electric System	Jason Fortik	Abstain	
3	Los Angeles Department of Water & Power	Mike Ancil	Abstain	
3	Louisville Gas and Electric Co.	Charles A. Freibert	Abstain	

3	M & A Electric Power Cooperative	Stephen D Pogue	Affirmative	
3	Manitoba Hydro	Greg C. Parent	Affirmative	
3	MEAG Power	Roger Brand	Affirmative	
3	MidAmerican Energy Co.	Thomas C. Mielnik	Affirmative	
3	Modesto Irrigation District	Jack W Savage	Affirmative	
3	Muscatine Power & Water	Jenn Stover		
3	National Grid USA	Brian E Shanahan	Affirmative	
3	Nebraska Public Power District	Tony Eddleman	Abstain	
3	New York Power Authority	David R Rivera	Affirmative	
3	Northeast Missouri Electric Power Cooperative	Skyler Wiegmann	Affirmative	
3	Northern Indiana Public Service Co.	Ramon J Barany	Abstain	
3	NW Electric Power Cooperative, Inc.	David McDowell	Affirmative	
3	Ocala Utility Services	Randy Hahn	Affirmative	
3	Oklahoma Gas and Electric Co.	Donald Hargrove	Affirmative	
3	Omaha Public Power District	Blaine R. Dinwiddie		
3	Orlando Utilities Commission	Ballard K Mutters	Affirmative	
3	Owensboro Municipal Utilities	Thomas T Lyons		
3	Pacific Gas and Electric Company	John H Hagen	Affirmative	
3	Platte River Power Authority	Terry L Baker	Affirmative	
3	PNM Resources	Michael Mertz		
3	Portland General Electric Co.	Thomas G Ward	Affirmative	
3	Potomac Electric Power Co.	Mark Yerger	Abstain	
3	Public Service Electric and Gas Co.	Jeffrey Mueller	Negative	SUPPORTS THIRD PARTY COMMENTS - (Public Service Enterprise Group)
3	Puget Sound Energy, Inc.	Mariah R Kennedy	Affirmative	
3	Rutherford EMC	Thomas Haire	Affirmative	
3	Sacramento Municipal Utility District	James Leigh-Kendall	Affirmative	
3	Salt River Project	John T. Underhill	Negative	SUPPORTS THIRD PARTY COMMENTS - (SRP)
3	Santee Cooper	James M Poston	Affirmative	
3	Seattle City Light	Dana Wheelock	Affirmative	
3	Seminole Electric Cooperative, Inc.	James R Frauen		
3	Sho-Me Power Electric Cooperative	Jeff L Neas		
3	Snohomish County PUD No. 1	Mark Oens	Affirmative	
3	South Carolina Electric & Gas Co.	Hubert C Young	Affirmative	
3	Southern California Edison Company	Lujuanna Medina	Affirmative	
3	Tacoma Power	Marc Donaldson	Abstain	
3	Tampa Electric Co.	Ronald L. Donahey		
3	Tennessee Valley Authority	Ian S Grant	Abstain	
3	Tri-State Generation & Transmission Association, Inc.	Janelle Marriott		
3	Westar Energy	Bo Jones	Affirmative	
3	Wisconsin Electric Power Marketing	James R Keller	Affirmative	
3	Xcel Energy, Inc.	Michael Ibold	Affirmative	
4	Alliant Energy Corp. Services, Inc.	Kenneth Goldsmith		
4	Blue Ridge Power Agency	Duane S Dahlquist	Affirmative	
4	City of Austin dba Austin Energy	Reza Ebrahimian	Affirmative	
4	City of New Smyrna Beach Utilities Commission	Tim Beyrle	Affirmative	
4	City of Redding	Nicholas Zettel	Affirmative	
4	City Utilities of Springfield, Missouri	John Allen		
4	Consumers Energy Company	Tracy Goble	Affirmative	
4	Cowlitz County PUD	Rick Syring	Affirmative	
4	DTE Electric	Daniel Herring	Affirmative	
4	Flathead Electric Cooperative	Russ Schneider		
4	Florida Municipal Power Agency	Carol Chinn	Affirmative	
4	Fort Pierce Utilities Authority	Cairo Vanegas	Affirmative	
4	Georgia System Operations Corporation	Guy Andrews	Affirmative	
4	Herb Schrayshuen	Herb Schrayshuen		
4	Illinois Municipal Electric Agency	Bob C. Thomas	Abstain	
4	Indiana Municipal Power Agency	Jack Alvey		
4	Integrus Energy Group, Inc.	Christopher Plante		

4	Madison Gas and Electric Co.	Joseph DePoorter	Affirmative	
4	Modesto Irrigation District	Spencer Tacke	Negative	COMMENT RECEIVED
4	Ohio Edison Company	Douglas Hohlbaugh	Abstain	
4	Oklahoma Municipal Power Authority	Ashley Stringer	Abstain	
4	Public Utility District No. 1 of Snohomish County	John D Martinsen	Affirmative	
4	Sacramento Municipal Utility District	Mike Ramirez	Affirmative	
4	Seattle City Light	Hao Li	Affirmative	
4	Seminole Electric Cooperative, Inc.	Steven R Wallace	Abstain	
4	South Mississippi Electric Power Association	Steve McElhaney		
4	Tacoma Public Utilities	Keith Morisette	Abstain	
4	Utility Services, Inc.	Brian Evans-Mongeon	Affirmative	
4	Wisconsin Energy Corp.	Anthony P Jankowski	Affirmative	
5	Acciona Energy North America	George E Brown	Affirmative	
5	AES Corporation	Leo Bernier		
5	Amerenue	Sam Dwyer	Affirmative	
5	American Electric Power	Thomas Foltz	Affirmative	
5	Arizona Public Service Co.	Scott Takinen	Affirmative	
5	Associated Electric Cooperative, Inc.	Matthew Pacobit	Affirmative	
5	Avista Corp.	Steve Wenke		
5	Basin Electric Power Cooperative	Mike Kraft	Affirmative	
5	BC Hydro and Power Authority	Clement Ma		
5	Black Hills Corp	George Tatar	Affirmative	
5	Boise-Kuna Irrigation District/dba Lucky peak power plant project	Mike D Kukla	Affirmative	
5	Bonneville Power Administration	Francis J. Halpin	Affirmative	
5	BP Wind Energy North America Inc	Carla Holly		
5	Brazos Electric Power Cooperative, Inc.	Shari Heino	Negative	SUPPORTS THIRD PARTY COMMENTS - (ACES)
5	Calpine Corporation	Hamid Zakery		
5	City and County of San Francisco	Daniel Mason		
5	City of Austin dba Austin Energy	Jeanie Doty	Affirmative	
5	City of Redding	Paul A. Cummings	Affirmative	
5	City of Tallahassee	Karen Webb	Abstain	
5	City Water, Light & Power of Springfield	Steve Rose		
5	Cleco Power	Stephanie Huffman	Affirmative	
5	Cogentrix Energy Power Management, LLC	Mike D Hirst		
5	Colorado Springs Utilities	Kaleb Brimhall	Negative	SUPPORTS THIRD PARTY COMMENTS - (PSEG) - (Colorado Springs Utilities)
5	Con Edison Company of New York	Brian O'Boyle	Affirmative	
5	Consumers Energy Company	David C Greyerbiehl	Affirmative	
5	Cowlitz County PUD	Bob Essex	Affirmative	
5	Dairyland Power Coop.	Tommy Drea		
5	Dominion Resources, Inc.	Mike Garton	Negative	SUPPORTS THIRD PARTY COMMENTS - (Dominion)
5	DTE Electric	Mark Stefaniak	Affirmative	
5	Duke Energy	Dale Q Goodwine	Affirmative	
5	E.ON Climate & Renewables North America, LLC	Dana Showalter		
5	EDP Renewables North America LLC	Heather Bowden	Negative	COMMENT RECEIVED
5	Entergy Services, Inc.	Tracey Stubbs		
5	Exelon Nuclear	Mark F Draper	Affirmative	
5	First Wind	John Robertson	Affirmative	
5	FirstEnergy Solutions	Kenneth Dresner	Abstain	
5	Florida Municipal Power Agency	David Schumann	Affirmative	
5	Great River Energy	Preston L Walsh	Affirmative	
5	Hydro-Québec Production	Roger Dufresne	Abstain	
5	Independence Power & Light Dept.	James Nail	Negative	SUPPORTS THIRD PARTY COMMENTS -

				(Southwest Power Pool)
5	Ingleside Cogeneration LP	Michelle R DAntuono	Abstain	
5	Invenergy LLC	Alan Beckham		
5	JEA	John J Babik		
5	Kansas City Power & Light Co.	Brett Holland	Affirmative	
5	Kissimmee Utility Authority	Mike Blough		
5	Lakeland Electric	James M Howard	Affirmative	
5	Liberty Electric Power LLC	Daniel Duff		
5	Lincoln Electric System	Dennis Florom	Abstain	
5	Los Angeles Department of Water & Power	Kenneth Silver	Abstain	
5	Lower Colorado River Authority	Dixie Wells	Affirmative	
5	Luminant Generation Company LLC	Rick Terrill	Affirmative	
5	Manitoba Hydro	Chris Mazur	Affirmative	
5	Massachusetts Municipal Wholesale Electric Company	David Gordon	Abstain	
5	MEAG Power	Steven Grego	Affirmative	
5	Muscatine Power & Water	Mike Avesing	Affirmative	
5	Nebraska Public Power District	Don Schmit	Abstain	
5	Nevada Power Co.	Richard Salgo	Affirmative	
5	New York Power Authority	Wayne Sipperly	Affirmative	
5	NextEra Energy	Allen D Schriver	Affirmative	
5	North Carolina Electric Membership Corp.	Jeffrey S Brame	Affirmative	
5	Northern Indiana Public Service Co.	Michael D Melvin	Abstain	
5	Oglethorpe Power Corporation	Bernard Johnson	Affirmative	
5	Oklahoma Gas and Electric Co.	Henry L Staples	Affirmative	
5	Omaha Public Power District	Mahmood Z. Safi	Affirmative	
5	Pacific Gas and Electric Company	Alex Chua	Affirmative	
5	Platte River Power Authority	Christopher R Wood	Affirmative	
5	Portland General Electric Co.	Matt E. Jastram	Affirmative	
5	PPL Generation LLC	Annette M Bannon	Abstain	
5	PSEG Fossil LLC	Tim Kucey		
5	Public Utility District No. 1 of Lewis County	Steven Grega		
5	Public Utility District No. 2 of Grant County, Washington	Michiko Sell	Affirmative	
5	Puget Sound Energy, Inc.	Lynda Kupfer	Affirmative	
5	Sacramento Municipal Utility District	Susan Gill-Zobitz	Affirmative	
5	Salt River Project	William Alkema	Negative	SUPPORTS THIRD PARTY COMMENTS - (Salt River Project)
5	Santee Cooper	Lewis P Pierce	Affirmative	
5	Seattle City Light	Michael J. Haynes	Affirmative	
5	Seminole Electric Cooperative, Inc.	Brenda K. Atkins		
5	Snohomish County PUD No. 1	Sam Nietfeld	Affirmative	
5	South Carolina Electric & Gas Co.	Edward Magic	Affirmative	
5	South Feather Power Project	Kathryn Zancanella		
5	Southern California Edison Company	Denise Yaffe	Affirmative	
5	Southern Company Generation	William D Shultz	Affirmative	
5	Tacoma Power	Chris Mattson	Abstain	
5	Tampa Electric Co.	RJames Rocha	Abstain	
5	Terra-Gen Power	Jessie Nevarez	Affirmative	
5	Tri-State Generation & Transmission Association, Inc.	Mark Stein		
5	TVA Power System Operations (PSO)	Brandy B Spraker	Abstain	
5	U.S. Army Corps of Engineers	Melissa Kurtz		
5	USD1 Bureau of Reclamation	Erika Doot	Abstain	
5	Westar Energy	Bryan Taggart	Affirmative	
5	Wisconsin Electric Power Co.	Linda Horn	Affirmative	
5	Wisconsin Public Service Corp.	Scott E Johnson		
5	Xcel Energy, Inc.	Mark A Castagneri	Affirmative	
6	AEP Marketing	Edward P. Cox	Affirmative	
6	Ameren Missouri	Robert Quinlivan		
6	APS	Randy A. Young	Affirmative	
6	Associated Electric Cooperative, Inc.	Brian Ackermann	Affirmative	
6	Basin Electric Power Cooperative	Stephen Farnsworth	Affirmative	
6	Bonneville Power Administration	Brenda S. Anderson	Affirmative	
6	Calpine Energy Services	Agus Bintoro		

6	City of Austin dba Austin Energy	Lisa Martin	Affirmative	
6	City of Redding	Marvin Briggs	Affirmative	
6	Cleco Power LLC	Robert Hirschak	Affirmative	
6	Colorado Springs Utilities	Shannon Fair	Negative	SUPPORTS THIRD PARTY COMMENTS - (PSEG) - (Colorado Springs Utilities)
6	Con Edison Company of New York	David Balban	Affirmative	
6	Constellation Energy Commodities Group	David J Carlson	Affirmative	
6	Dominion Resources, Inc.	Louis S. Slade	Negative	SUPPORTS THIRD PARTY COMMENTS - (Dominion)
6	Duke Energy	Greg Cecil	Affirmative	
6	FirstEnergy Solutions	Kevin Querry	Abstain	
6	Florida Municipal Power Agency	Richard L. Montgomery	Affirmative	
6	Florida Municipal Power Pool	Thomas Reedy	Affirmative	
6	Florida Power & Light Co.	Silvia P Mitchell	Affirmative	
6	Kansas City Power & Light Co.	Jessica K Klinghoffer	Affirmative	
6	Lakeland Electric	Paul Shipps	Affirmative	
6	Lincoln Electric System	Eric Ruskamp	Abstain	
6	Los Angeles Department of Water & Power	Brad Packer	Abstain	
6	Lower Colorado River Authority	Michael Shaw	Affirmative	
6	Luminant Energy	Brenda Hampton	Affirmative	
6	Manitoba Hydro	Blair Mukanik	Affirmative	
6	Modesto Irrigation District	James McFall	Affirmative	
6	Muscatine Power & Water	John Stolley		
6	New York Power Authority	Shivaz Chopra	Affirmative	
6	New York State Electric & Gas Corp.	Julie S King		
6	Northern Indiana Public Service Co.	Joseph O'Brien	Abstain	
6	Oglethorpe Power Corporation	Donna Johnson	Affirmative	
6	Oklahoma Gas and Electric Co.	Jerry Nottmangel	Affirmative	
6	Omaha Public Power District	Douglas Collins		
6	PacifiCorp	Sandra L Shaffer	Affirmative	
6	Platte River Power Authority	Carol Ballantine	Affirmative	
6	Portland General Electric Co.	Shawn P Davis	Affirmative	
6	Powerex Corp.	Gordon Dobson-Mack		
6	PPL EnergyPlus LLC	Elizabeth Davis	Abstain	
6	PSEG Energy Resources & Trade LLC	Peter Dolan	Negative	SUPPORTS THIRD PARTY COMMENTS - (Public Service Enterprise Group)
6	Public Utility District No. 1 of Chelan County	Hugh A. Owen		
6	Sacramento Municipal Utility District	Diane Enderby	Affirmative	
6	Salt River Project	William Abraham	Negative	SUPPORTS THIRD PARTY COMMENTS - (Salt River Project)
6	Santee Cooper	Michael Brown	Affirmative	
6	Seattle City Light	Dennis Sismaet	Affirmative	
6	Seminole Electric Cooperative, Inc.	Trudy S. Novak		
6	Snohomish County PUD No. 1	Kenn Backholm	Affirmative	
6	South Carolina Electric & Gas Co.	Matt H Bullard	Affirmative	
6	Southern California Edison Company	Joseph T Marone	Affirmative	
6	Southern Company Generation and Energy Marketing	John J. Ciza	Affirmative	
6	Tacoma Public Utilities	Michael C Hill	Abstain	
6	Tampa Electric Co.	Benjamin F Smith II		
6	Tennessee Valley Authority	Marjorie S. Parsons	Abstain	
6	Westar Energy	Grant L Wilkerson	Affirmative	
7	Luminant Mining Company LLC	Stewart Rake	Affirmative	
7	Occidental Chemical	Venona Greaff		
7	Siemens Energy, Inc.	Frank R. McElvain		
8		Roger C Zaklukiewicz	Affirmative	



8		David L Kiguel	Affirmative	
8	Massachusetts Attorney General	Frederick R Plett	Affirmative	
8	Volkman Consulting, Inc.	Terry Volkman	Affirmative	
9	Commonwealth of Massachusetts Department of Public Utilities	Donald Nelson	Affirmative	
9	New York State Public Service Commission	Diane J Barney		
10	Florida Reliability Coordinating Council	Linda C Campbell		
10	Midwest Reliability Organization	Russel Mountjoy	Affirmative	
10	New York State Reliability Council	Alan Adamson	Affirmative	
10	Northeast Power Coordinating Council	Guy V. Zito	Affirmative	
10	ReliabilityFirst	Anthony E Jablonski	Affirmative	
10	SERC Reliability Corporation	Joseph W Spencer	Affirmative	
10	Texas Reliability Entity, Inc.	Karin Schweitzer	Affirmative	
10	Western Electricity Coordinating Council	Steven L. Rueckert	Affirmative	

Legal and Privacy : 404.446.2560 voice : 404.467.0474 fax : 3353 Peachtree Road, N.E. : Suite 600, North Tower : Atlanta, GA 30326
 Washington Office: 1325 G Street, N.W. : Suite 600 : Washington, DC 20005-3801

[Account Log-In/Register](#)

Copyright © 2014 by the North American Electric Reliability Corporation. : All rights reserved.
 A New Jersey Nonprofit Corporation

Individual or group. (36 Responses)
Name (22 Responses)
Organization (22 Responses)
Group Name (14 Responses)
Lead Contact (14 Responses)
Question 1 (32 Responses)
Question 1 Comments (34 Responses)
Question 2 (32 Responses)
Question 2 Comments (34 Responses)
Question 3 (30 Responses)
Question 3 Comments (34 Responses)
Question 4 (28 Responses)
Question 4 Comments (34 Responses)
Question 5 (27 Responses)
Question 5 Comments (34 Responses)
Question 6 (30 Responses)
Question 6 Comments (34 Responses)

Individual
Heather Bowden
EDP Renewables North America LLC
No
For consistency, it should be considered to have PRC-004 and PRC-005 to be applicable at an aggregate of greater than or equal to 75 MVA of BES facilities.
No
For consistency, it should be considered to have PRC-004 and PRC-005 to be applicable at an aggregate of greater than or equal to 75 MVA of BES facilities.
No
For consistency, it should be considered to have PRC-004 and PRC-005 to be applicable at an aggregate of greater than or equal to 75 MVA of BES facilities.
Yes
Yes
Thank you for your time and efforts.
Individual
Jim Nail`
Independence Power & Light
Group
Northeast Power Coordinating Council
Guy Zito
Yes
Yes
Yes
Yes
Yes

No
Individual
Joe Butterfield
Wisconsin Public Service Corporation
No
The PRC-005-2(X) facilities sections (4.2.6 and 4.2.6.1) should be clarified and consistent with section 4.2.5. Suggested clarification: 4.2.6 Protection Systems for the following BES dispersed power producing resources identified through Inclusion I4 of the BES definition; excluding the individual resources: 4.2.6.1 Protection Systems that act to trip a common point of connection at 100 kV or above where those resources aggregate to greater than 75 MVA, either directly or via a lockout relay. OR 4.2.6.1 Protection Systems that act to trip dispersed power producing resources common point of connection at 100 kV or above where those resources aggregate to greater than 75 MVA, either directly or via lockout relay.
No
The PRC-005-3(X) facilities sections (4.2.6 and 4.2.6.1) should be clarified and consistent with section 4.2.5. Suggested clarification: 4.2.6 Protection Systems for the following BES dispersed power producing resources identified through Inclusion I4 of the BES definition; excluding the individual resources: 4.2.6.1 Protection Systems that act to trip a common point of connection at 100 kV or above where those resources aggregate to greater than 75 MVA, either directly or via a lockout relay. OR 4.2.6.1 Protection Systems that act to trip dispersed power producing resources common point of connection at 100 kV or above where those resources aggregate to greater than 75 MVA, either directly or via lockout relay.
No
The PRC-005-X(X) facilities sections (4.2.6 and 4.2.6.1) should be clarified and consistent with section 4.2.5. Suggested clarification: 4.2.6 Protection Systems for the following BES dispersed power producing resources identified through Inclusion I4 of the BES definition; excluding the individual resources: 4.2.6.1 Protection Systems that act to trip a common point of connection at 100 kV or above where those resources aggregate to greater than 75 MVA, either directly or via a lockout relay. OR 4.2.6.1 Protection Systems that act to trip dispersed power producing resources common point of connection at 100 kV or above where those resources aggregate to greater than 75 MVA, either directly or via lockout relay. In addition, there should be further clarification surrounding the inclusion/exclusion of the sudden pressure relay.
Yes
Yes
No
Group
Arizona Public Service Company
Janet Smith
Yes
Yes
Yes
Yes
Yes
Yes

No
Individual
Terry Volkmann
Volkman COnsulting, Inc
Yes
Yes
Yes
No
The change is neither consistent with the delineation in PRC-004 / 5 nor inclusive of the dispersed generation issue. My interpretation is that VAR-002 change only address change in reactive capability and does not address automatic voltage control and status at each generator site. VAR-002 should be written explicitly to only applicable at the point of aggregation to 75 MVA with the transmission system.
No
see question 4
No
Individual
John Seelke
Public Service Enterprise Group
No
In 4.2.6.1, "75MVA should be changed to "20MVA." This would make it comparable to I2 generators. Although the change to 20MVA would have this standard apply to non-BES assets, many standards do likewise. In fact "Protection Systems," which are the subject of this standard, are non-BES. As written, a reliability gap would be created between I4 generators and I2 generators. The proposed change violates Section 303 of the NERC Rules of Procedure, paragraph 1 that states: "Competition - A Reliability Standard shall not give any market participant an unfair competitive advantage." If alternative language was proposed that required the same 75MVA threshold for I2 generators, PSEG would be fine with that. But the proposed non-comparable treatment of generators is not acceptable.
No
The same comments in Q1 apply.
No
The same comments in Q1 apply.
No
How does one interpret the added "bullet" in R3? The new bullet statement belongs in the Applicability section. Furthermore, the statement creates a reliability gap between I4 generators and I2 generators. It also violates Section 303 of the NERC Rules of Procedure, paragraph 1 that states: "Competition - A Reliability Standard shall not give any market participant an unfair competitive advantage." We suggest the following addition to the bullet to correct both issues (added language is CAPITALIZED): "... Bulk Electric Definition; HOWEVER, REPORTING CHANGES ARE REQUIRED AT THE POINT THAT INDIVIDUAL INCLUSION I4 BES GENERATORS AGGREGATE TO GREATER THAN 20MVA."
No
The same comments in Q3 apply, except replace "R3" with "R4."
No

Individual
Anthony Jablonski
ReliabilityFirst
Yes
ReliabilityFirst submits the following comments for consideration: 1. VAR-002-2b(X) Requirement 3, Part 3.1 - The exclusion for dispersed power producing resources is shown as a bullet point and bullet points are historically described as "OR" statements in NERC Reliability Standards. ReliabilityFirst recommends adding the bulleted language to the end of Requirement 3, Part 3.1 as follows: "A status or capability change on any generator Reactive Power resource, including the status of each automatic voltage regulator and power system stabilizer and the expected duration of the change in status or capability. Reporting of status or capability changes is not applicable to the individual dispersed power producing resources identified through Inclusion I4 of the Bulk Electric System definition."
Group
MRO NSRF
Joseph DePoorter
No
The proposed wording within the Applicability section of 4.2.5 is very wordy and without the Rational box for 4.2.5, entities will be very confused. The NSRF recommend that 4.2.5 be reworded to read; "Protection Systems for BES generation Facilities (Inclusion I4 assets are contained within section 4.2.6)". This will allow all BES connected generators to be covered by this Standard and clearly describes what is applicable per Inclusion I4 via 4.2.6.
No
See comments per question 1.
No
See comments per question 1.
No
The NSRF agrees with the proposed Requirements but has issues with the associated Rational for Footnote 5 in R4, Part 4.1, note that Transmission Provider should be Transmission Planner. The auxiliary transformers stated in R4.1 are usually transformers that provide station services to the generator. The first sentence of the Ration is correct. The second sentence is out of line since it is directed to the collector system (34.5kV), this should be deleted. This rewrite will provide simple clarity that the foot note is trying to provide.
No
The bulleted item under R4 is too wordy and recommend the following rewrite to provide clarity; "Reporting of reactive capability changes is not applicable to (delete "the") individual (delete "for ") dispersed power producing resources identified through Inclusion I4 of the Bulk Electric System definition.
Yes
Please note that NERC has already written a proposed Guidance document on these Standards, including PRC-004. The NSRF, request that the SDT coordinate with NERC so that any Standard and Guidance document complement each other.
Individual
Thomas Foltz
American Electric Power
Yes

Yes
Yes
Was the omission of sudden pressure relays for dispersed generation resources under PRC-005-X Applicability 4.2.6 intentional? In light of the FERC directive associated with SPRs, we are unsure if FERC will accept a version of the standard that does not require testing of SPRs for transformers connected between the point that the resources aggregate to greater than 75 MVA and the point of interconnection.
Yes
Yes
No
Individual
Jo-Anne Ross
Manitoba Hydro
Yes
Yes
Yes
Yes
Yes
No
Individual
Si Truc PHAN
Hydro-Quebec TransEnergie
No
In Quebec, the RTP (Main Transmission System) Elements are applied instead of BES Elements. The Generation Facilities are greater than 50 MVA / 44kV instead of 75 MVA. Also in Quebec, NO Dispersed Generation is connected into the RTP network. To facilitate the compliance, the expression 'inclusion I4' should NOT include in the standard.
No
See response in question 1
No
See response in question 1
No
See response in question 1
No
Group
Dominion
Connie Lowe

No
Dominion recommends revising 4.2.5 to read "Protection Systems for the following BES generator Facilities identified through Inclusions I2 and I3 of the BES definition:" as we believe it is more appropriate to cite how these BES generators are included under this section as opposed to indicating how they are not applicable under this section. Currently the standard's applicability is based first on the NERC Registration Criteria and secondly on facilities identified within the standard (4.2.5 Protection Systems for generator Facilities), regardless of their BES status. This proposed revisions means to change the applicability of the standard first to the NERC Registration Criteria and secondly on facilities identified within the standard (4.2.5 Protection Systems for BES generator Facilities). This BES generator Facilities change in 4.2.5 (i.e. Inclusions I2 and I3) essentially means the Protection System to be considered now is the "generator including the generator terminals through the high-side of the step-up transformer" and no longer considers protection to the point of interconnection.
No
Dominion recommends revising 4.2.5 to read "Protection Systems for the following BES generator Facilities identified through Inclusions I2 and I3 of the BES definition:" as we believe it is more appropriate to cite how these BES generators are included under this section as opposed to indicating how they are not applicable under this section.
No
Dominion recommends revising 4.2.5 to read "Protection Systems for the following BES generator Facilities identified through Inclusions I2 and I3 of the BES definition:" as we believe it is more appropriate to cite how these BES generators are included under this section as opposed to indicating how they are not applicable under this section.
Yes
Rationale for R4, need to change Transmission Provider to 'Transmission Planner'. Since this standard is being revised, Dominion suggests that NERC request the SDT to re-align the Measures with the Requirements to develop a more risk-based standard as NERC has proposed going forward.
Yes
Rationale for R5, need to change Transmission Provider to 'Transmission Planner'.
Yes
Dominion, from a philosophical perspective, cannot support a continent-wide standard (VAR-002) that does not grant a waiver (or waivers) where one or more approved regional standard exists. We cite the following as reason supporting this philosophy; PRC-006, Docket # RM11-20 - In Order No. 763 (issued on May 7, 2012), the Commission directed NERC to submit a Compliance Filing regarding several aspects including how it will address the Commission's directive to establish a schedule by the planning coordinator to comply with PRC-006-1 Requirement R9. In its compliance filing, NERC stated that an entity must be compliant with both the continent wide PRC-006 Standard and the regional standard proposed by SERC in Docket No. RM12-9. Dominion intervened requesting that the Commission modify Requirement R6 to require each UFLS entity in the SERC Region to implement changes to the UFLS scheme within the lesser of 18 months of notification by the planning coordinator, or the schedule established by the planning coordinator. In reply to SERC's responsive comments, Dominion disagrees that its concerns have been adequately addressed. Dominion states that "it is unjust to hold a registered entity responsible for compliance to any requirement within a reliability standard where such compliance is dependent upon that registered entity having also read, and taken into consideration, all statements issued by FERC, NERC and the Regional Entity. The Commission declined Dominion's request and instead affirmed the interpretation as set forth in NERC and SERC's comments. PRC-002-2 – NPCC received approval of its regional standard (PRC-002-NPCC-01) in October 2011. That standard also contained an implementation plan which provides staggered effective dates, i.e., the date on which applicable entities are subject to mandatory compliance, with full compliance required within four years of regulatory approval. During the comment period, Dominion stated potential for conflict between the approved regional standard and the draft continent-wide standard, and also noted that registered entities in that region are 2 years into the 4 year implementation which creates uncertainty for NPCC applicable entities. The drafting team's response did not adequately address Dominion's concerns. Dominion does not agree with the response provided by the SDT relative to comments related to PRC-006, specifically the regional (NPCC and SERC) versions. Both of these approved regional standards apply to

Generator Owner and we therefore agree that the SDT should include the continent wide standard in its review.
Group
Duke energy
Michael Lowman
Yes
Yes
Yes
Yes
Duke Energy suggests the following revision: "Reporting of status or capability changes is not applicable to the individual dispersed power producing resources identified through Inclusion I4 (a) of the Bulk Electric System definition." We believe the addition of "I4 (a)" helps clarify the applicability for individual dispersed power producing resources.
Yes
Duke Energy suggests the following revision: "Reporting of reactive capability changes is not applicable to the individual dispersed power producing resources identified through Inclusion I4 (a) of the Bulk Electric System definition." We believe the addition of "I4 (a)" helps clarify the applicability for individual dispersed power producing resources. We would also like to point out an apparent typo in R4 and suggest modifying "individual for dispersed power producing resources" to "individual dispersed power producing resources". The removal of "for" provides consistency with the language in VAR-002-2b.
Yes
PRC-005 Implementation Plans: We suggest removing "first day following" in all the PRC-005 implementation plans. It appears that as written, there could be a gap between the effective date and retirement date of these standards. VAR-002-2b RSAW : We suggest adding I4 (a) to the R3 Note To Auditor Section of the RSAW for consistency with our comments to Question 4 as follows: "Requirement R3.1 is not applicable to individual dispersed power producing resources identified through Inclusion I4 (a) of the Bulk Electric System definition. Entity assertions regarding applicability of Requirement R3.1 should be supported by evidence such as one-line diagrams, nameplate ratings, manufacturer information, or BES inclusion documentation available at the Regional Entity." VAR-002-3 RSAW : We suggest adding I4 (a) to the R4 Note To Auditor Section of the RSAW with our comments to Question 5 as follows: "Requirement R4 is not applicable to the individual dispersed power producing resources identified through Inclusion I4 (a) of the Bulk Electric System definition. Entity assertions regarding applicability of Requirement R4 should be supported by evidence such as one-line diagrams, nameplate ratings, manufacturer information, commissioning tests, etc."
Individual
Timothy Brown
Idaho Power
No
Inclusion I4 of the BES definition specifically includes each generating resource. It is inconsistent to not include them for testing the protection systems under PRC-005. As written, there would be portions of the Bulk Electric System that would not be required to have the protection systems tested. A GO with a plant of small units aggregating above 75 MVA would be required to test the protection systems on all their units. How is this equitable? I understand that you have addressed this issue in the Consideration of Comments for the White Paper (Pg 9 & 10), however I disagree with your conclusion. If they individual resources are insignificant to test, they why are they considered part of the BES?
No
See discussion in #1.

No
See discussion in #1.
Yes
Yes
Individual
Karin Schweitzer
Texas Reliability Entity
Yes
Yes
Yes
Yes
Yes
Yes
1)Texas RE agrees with the change to applicability but points out that there may be an error in the language of R5 of VAR-002-4. Requirement 4 and 5 have the exact same requirement language: "Each Generator Operator shall notify its associated Transmission Operator within 30 minutes of becoming aware of a change in reactive capability due to factors other than a status change described in Requirement R3. If the capability has been restored within 30 minutes of the Generator Operator becoming aware of such change, then the Generator Operator is not required to notify the Transmission Operator of the change in reactive capability." Requirement 5 goes on to add: "For generator step-up transformers and auxiliary transformers5 with primary voltages equal to or greater than the generator terminal voltage: 5.1.1. Tap settings. 5.1.2. Available fixed tap ranges. 5.1.3. Impedance data. The requirements in VAR-002-2b (R4) and VAR-002-3 (R5) that include the tap settings, ranges and impedance data language have the following requirement language: "The Generator Owner shall provide the following to its associated Transmission Operator and Transmission Planner within 30 calendar days of a request." Texas RE requests the SDT review the language to assure the correct requirement language is included in Requirement R5 of VAR-002-4. 2)It appears that R7 of VAR-002-4 should actually be the Measure for R6, not a Requirement. 3)It appears that VAR-002-2b(X) Requirement R3.1 and VAR-002-4 Requirement R4 map to each other but the exclusion language is slightly different. VAR-002-4, R4 has the word "for" between "individual" and "dispersed power" whereas VAR-002-2b(X) does not. The addition of the word makes the requirement confusing. It may just be a typo but Texas RE wanted to bring this to the attention of the SDT. VAR-002 -2b(X) Requirement R3.1 language: Reporting of status or capability changes is not applicable to the individual dispersed power producing resources identified through Inclusion I4 of the Bulk Electric System definition. VAR-002-4 Requirement R4 language: Reporting of reactive capability changes is not applicable to the individual for dispersed power producing resources identified through Inclusion I4 of the Bulk Electric System definition.
No
Group
DTE Electric
Kathleen Black
Yes
Yes

Yes
Yes
Yes
No
Group
FirstEnergy
Cindy Stewart
No
FirstEnergy abstains as we are not directly impacted by this project. Please see our response to Question #6.
No
FirstEnergy abstains as we are not directly impacted by this project. Please see our response to Question #6.
No
FirstEnergy abstains as we are not directly impacted by this project. Please see our response to Question #6.
No
FirstEnergy abstains as we are not directly impacted by this project. Please see our response to Question #6.
No
FirstEnergy abstains as we are not directly impacted by this project. Please see our response to Question #6.
Yes
FirstEnergy abstains as we are not directly impacted by this project. We question the efficiency of modifying several NERC Reliability Standards in lieu of potentially adjusting the NERC BES definition which may more effectively address the concerns. Additionally there are other revisions to the NERC BES definition needed in regard to generation assets. As written, there is inequality in the NERC BES definition for traditional generation resources versus dispersed generation. A single traditional unit of 25 MVA must meet all NERC Reliability Standards that apply to Generator Owners yet for the dispersed generation they are only subject to the extent that they total 75 MVA or more. When there are standards before FERC pending regulatory approval, all subsequent revisions should be based on the latest NERC Board approved version. It is our opinion that the approach taken to modify and post for ballot several versions of the same standard is inefficient, overly complicated and unnecessarily causes industry confusion. We suggest that the NERC Standards Committee reassess the need to make this a standalone project and work the intended revisions into current ongoing projects.
Individual
David Jendras
Ameren
Yes
Ameren adopts the SERC PCS comments by reference
Yes
Ameren adopts the SERC PCS comments by reference
Yes
Ameren adopts the SERC PCS comments by reference
Yes

No
(1) Regarding proposed standard VAR-002-4, we believe that some language is missing for requirement R5.1. Shouldn't the requirement state that the Generator Operator needs to provide the information on Tap Settings, Available fixed tap ranges, and Impedance data to the Transmission Operator? (2) We believe that VAR-002-4 should include a 30 day time period to complete R5, as alluded to in M5.
No
Group
SERC Protection and Controls Subcommittee
David Greene
Yes
Please word the standard to clearly identify that PRC-005 becomes applicable on facilities where the aggregate generation sums to > 75MVA and it connects at >100kV. Please refer to Figures in the BES Definition Reference document to clearly identify the applicable facilities where the aggregate generation sums to > 75MVA and it connects at >100kV. For example in the BES Definition Reference Document Figures I4-1 through I4-4, is the protection system on the blue bus in the purple circle included given that the green feeders are not BES? Or, is just the transformer protection applicable since it is clearly all blue (BES) in the diagram? As another example in the BES Definition Reference Document Figure I4-1, can each of the 4 green strings of distributed generation be owned by the same or different companies, located at one or separate locations and the blue collector bus actually be a sub transmission line (or distribution line)?
Yes
See comments with Question 1.
Yes
See comments with Question 1.
no comment
no comment
No
The comments expressed herein represent a consensus of the views of the above-named members of the SERC EC Protection and Control Subcommittee only and should not be construed as the position of SERC Reliability Corporation, its board, or its officers.
Group
Florida Municipal Power Agency
Carol Chinn
Yes
Yes
Yes
In the rationale for Footnote 5 in Requirement R4, Part 4.1 the references to Transmission Provider should be Transmission Planner. The reference to "Transmission" should be Transmission Planner.
In the added bullet to R4, the word "for" should be deleted. In the rationale for Footnote 5 in Requirement R5, Part 5.1 the references to Transmission Provider should be deleted. The reference to "Transmission" should be deleted. Although not in the scope of this particular SDT, the reference to Transmission Planner in M5 should be deleted since notification is not required by R5.
No
Group
SPP Standards Review Group

Robert Rhodes
No
Rewrite the 1st line under Description of Current Draft to read: 'This version of PRC-005 contains revisions to the applicability of the Standard intended to...' This eliminates the redline typo. In order to minimize confusion regarding the use of the term 'Facilities' versus 'facilities' in the Applicability Section, we recommend changing the heading of 4.2 to 'Applicable facilities'. Insert a space between the 'apply' and the 'only' in the 6th line of the Rationale Box for 4.2.6. Also expand the box down to capture all of the last line. We also suggest that the formatting in 4.2.6 parallel the formatting, or construction, of 4.2.5 in that specifics are listed in 4.2.5 and they are absent in 4.2.6. Or the drafting team could go in the other direction and modify 4.2.5 to match 4.2.6. The redline version contained several Rationale Boxes which are missing from the clean version. Were the boxes holdovers from previous versions making the clean version the correct copy or were they supposed to be included in the clean version?
No
In order to minimize confusion regarding the use of the term 'Facilities' versus 'facilities' in the Applicability Section, we recommend changing the heading of 4.2 to 'Applicable facilities'. We also suggest that the formatting in 4.2.6 parallel the formatting, or construction, of 4.2.5 in that specifics are listed in 4.2.5 and they are absent in 4.2.6. Or the drafting team could go in the other direction and modify 4.2.5 to match 4.2.6.
No
Shouldn't the reference to PRC-005-3 in the 2nd line under the Description of Current Draft be to PRC-005-4? The redline version shows a Rationale Box with the Introduction Section. This box, even though it contains redline changes, is not included in the clean version. Were the redline changes holdovers from a previous version and should not have been shown in this redline or were they supposed to be included in the clean version? In order to minimize confusion regarding the use of the term 'Facilities' versus 'facilities' in the Applicability Section, we recommend changing the heading of 4.2 to 'Applicable facilities'. The page header includes the PRC-005-4(X) label while within the standard itself it is shown as PRC-005-X. Which is correct? We would also suggest that the formatting in 4.2.6 parallel the formatting, or construction, of 4.2.5 in that specifics are listed in 4.2.5 and they are absent in 4.2.6. Or the drafting team could go in the other direction and modify 4.2.5 to match 4.2.6. The Rationale Boxes for 4.2.5 and 4.2.6 cover-up text. The boxes need to be moved such that they do not cover-up any text.
No
References to R4 and R5 in the Description of Current Draft Section should be to R3 and R4. Also delete the BES in front of Bulk Electric Systems in the line in which the references are made. The proposed change to Requirement R3, Part 3.1 is okay as long as the number of individual units in an aggregated site is not detrimental to the overall operation of the entire site. In that case, the site status, for the entire aggregated facility, should be reported. If this is the intent of Part 3.2, it needs additional clarification to make it stand out. The Rationale Box for Footnote 5 references the Transmission Provider and in one instance only references Transmission. We believe these references should be to the Transmission Planner as indicated in Requirement R4.
No
Since VAR-002-4 only contains minor technical revisions dealing with the applicability specifically for Requirements R4 and R5, is it feasible to believe that VAR-002-4 will be approved before VAR-002-3? The special provisions for 'the later of' aren't needed. Simply go with the normal Effective Date language. Additionally, the way this section is currently worded in those jurisdictions requiring governmental approval, the standard becomes effective immediately upon governmental approval. Yet, if governmental approval is not required, the standard would become effective the first day of the first calendar quarter following NERC Board approval. The concept of 'the first day of the first calendar quarter following approval' needs to be added to the governmental approval clause. The same argument applies to the proposed change for Requirement R4 as we put forth in response to the proposed change to Requirement R3, Part 3.1 in VAR-002-2b(X) in Question 4. The proposal is okay provided that only lost capability of a few individual units does not detract from the overall capability of the entire aggregated site. If the capability of the entire site is degraded the notification should be made. Also, insert the term 'generator' between 'individual' and 'for' in the bullet under Requirement R4. Requirement R5 is a duplicate of Requirement R4 and needs to be replaced with

the correct wording from VAR-002-2b(X), Requirement R4. The clean version is missing the Rationale Box for Footnote 5.
Yes
The various Implementation Plans for each version of PRC-005 are cross referenced in the Implementation Plans for PRC-005-2(X), PRC-005-3(X) and PRC-005-X(X) in this project. We suggest a change in language to an item in the Background Section of each of those referenced Implementation Plans. We propose the following: '2. For entities not presently performing a maintenance activity or using longer intervals than the maximum allowable intervals established in the proposed standard, it is unrealistic for those entities to be immediately compliant with the new activities or intervals. Further, entities should be allowed to become compliant in such a way as to facilitate a continuing maintenance program. Those entities which now fall under the requirements of the standard due to BES definition changes would have twenty-four months from the applicable effective date to demonstrate compliance.' This would eliminate the potential for a repeat of the fiasco of a few years back associated with implementation of PRC-005-1 in which evidence of compliance was required prior to the effective date of the standard. There is inconsistency among the proposed standards on the term dispersed power producing facilities. In some instances power producing is hyphenated, in others it is not. In some instances facilities is capitalized, in others it is not. The SDT needs to determine which is correct and stick to it. There is inconsistency among the proposed standards on the use of the terms 75 MVA and 100 kV. In some instances they are shown with the space and in others they are shown without the space as 75MVA and 100kV. The SDT, again, needs to determine which is correct and stick to it.
Individual
John Pearson
ISO New England
No
Under the standard, a conventional generating resource has to have a documented protection maintenance program which it must follow to ensure reliability. On the other hand, under the proposed revisions to the standard, a similarly-sized, dispersed power producing resource would not be required to do the same. If the standard is not applied to the dispersed generation resource, then there is no required protection maintenance, which can (and does in practice) result in more frequent trips, and degraded reliability. Loss of the dispersed generation resource (as distinct from individual units) would have the same impact as loss of a single, similarly sized conventional generating resource. Thus, a maintenance program that applies beyond the common point of connection should be required. The maintenance program should definitely be tailored to the type of dispersed generation power producing resource as determined by the GO/GOP, but having no requirement in place does not ensure reliable operations.
No
See response for Question 1
No
See response for Question 1
Yes
In PRC-005-2(X), under A.2, the number "2" should not have been deleted and the letter "X" should be in parenthesis as it is shown in the header. In PRC-005-2(X), and VAR-002-2b(X), under D. Compliance 1.1 – It is not necessary to repeat the definition of Compliance Enforcement Authority. A reference to the NERC Rules of Procedure is sufficient. The benefit is that, if the definition ever changes there, it will not have to be changed here. Therefore, 1.1 under Compliance should simply say: "Compliance Enforcement Authority" has the meaning ascribed to it in the NERC Rules of Procedure.
Individual
John Robertson
First Wind
Yes

Applicability is adequate for reliability.
Yes
Applicability is adequate for reliability.
Yes
Applicability is adequate for reliability.
Yes
Yes
No
Individual
George Brown
Acciona Energy North America Corporation
Yes
Yes
Yes
Yes
No
I agree with the intent of the SDT, however, the balloted version VAR-002-4 is incorrect. VAR-002-4 R4: added applicability clause is incorrect and misworded VAR-002-4 R5: Requirement is incorrect and not original requirement from version 3 of this standard
No
Individual
Israel Beasley
Georgia Transmission Corporation
Yes
Yes
The only comments I would suggest are fixing the wording in the Automatic Reclosing section 4.2.7.2 of PRC-005-3/PRC-005-X to refer to section 4.2.7.1 instead of 4.2.6.1. It appears this change was simply overlooked.
Yes
The only comments I would suggest are fixing the wording in the Automatic Reclosing section 4.2.7.2 of PRC-005-3/PRC-005-X to refer to section 4.2.7.1 instead of 4.2.6.1. It appears this change was simply overlooked.
Yes
The only comments I would suggest are fixing the wording in the Automatic Reclosing section 4.2.7.2 of PRC-005-3/PRC-005-X to refer to section 4.2.7.1 instead of 4.2.6.1. It appears this change was simply overlooked.
Group
IRC Standards Review Committee
Greg Campoli

Yes
Yes
Yes
The proposed change to Requirement R3, Part 3.1 is okay as long as the net change to number of the individual units in an aggregated site is not detrimental to affect the overall operation of the entire site or the proper management and control of reactive resources of the site. In that case, the site status, for the entire aggregated facility, should be reported. If this is the intent of Part 3.2 is intended to cover the latter situation (where the impact of changes to individual disperse generating sources is reported at the aggregate level), then Part 3.2 needs , it needs additional to be expanded to clarify it. clarification to make it stand out. Otherwise, the impact of changes to individual units will not be identified and reported for control to meet the objective of control and management of reactive resources. The Rationale Box for Footnote 5 references the Transmission Provider and in one instance only references Transmission. We believe these references should be to the Transmission Planner as indicated in Requirement R4.
Yes
There are multiple postings of the PRC-005 currently underway, each effort addressing different changes. Although we support and understand the need to adhere to the standards development process for standards projects, each one will have individual postings and ballots. This makes it cumbersome to reference and review layers of changes that may impact the other postings and can lead to confusion and unanticipated voting outcomes. The drafting teams need to explain how each proposed change to PRC-005 is not relevant or impactful on the other.
Individual
Joshua Andersen
Salt River Project
Yes
Yes
No
Sudden pressure relays are not "necessary", in fact, older transformers will likely not have them. What is necessary for "reliable operation" as defined in the statute are the differential relays, overcurrent relays, etc., that are there to clear a major phase to phase or phase to ground fault that if left uncleared can cause instability. A sudden pressure relay is there primarily for equipment health monitoring, e.g., detecting a turn-to-turn failure, not a phase to ground or phase to phase fault. If a sudden pressure relay fails to operate, there is no threat to BPS reliability since the differential relay / overcurrent relays are there if the fault develops into a major phase to ground or phase to phase fault.
Yes
Yes
No
Group
ACES Standards Collaborators
Jason Marshall
Yes
We agree with the changes.

Yes
We agree with the changes.
Yes
We agree with the changes.
Yes
(1) We agree with the proposed changes. However, we believe additional changes are needed to the standard. (2) Requirement R1 needs to be modified as well. Because each individual generating unit of a dispersed generation site that exceeds the 75 MVA threshold is included as part of the BES, R1 would apply and would require each of these units to be operated with AVR in voltage regulating mode. These units usually do not have an AVR and are not capable of controlling voltage. Rather, they rely on other voltage regulating equipment such as SVC or capacitor banks to control voltage at the interconnecting point. Thus, we request that R1 is modified so that is not applicable to the individual units of the dispersed power producing resources. (3) Similar to R1, R2 should also be modified to reflect that these dispersed generation resources often do not have AVRs and must rely on other voltage regulating equipment to control voltage at the interconnecting point. Thus, we request that R2 is modified so that is not applicable to the individual units of the dispersed power producing resources.
Yes
(1) We agree with the proposed changes. However, we believe additional changes are needed to the standard. (2) Requirement R1 needs to be modified as well. Because each individual generating unit of a dispersed generation site that exceeds the 75 MVA threshold is included as part of the BES, R1 would apply and would require each of these units to be operated with AVR in voltage regulating mode. These units usually do not have an AVR and are not capable of controlling voltage. Rather, they rely on other voltage regulating equipment such as SVC or capacitor banks to control voltage at the interconnecting point. Thus, we request that R1 is modified so that is not applicable to the individual units of the dispersed power producing resources. (3) Similar to R1, R2 should also be modified to reflect that these dispersed generation resources often do not have AVRs and must rely on other voltage regulating equipment to control voltage at the interconnecting point. Thus, we request that R2 is modified so that is not applicable to the individual units of the dispersed power producing resources.
No
Individual
Steven Lancaster
BES
Group
Southern Company: Southern Company Services, Inc.; Alabama Power Company; Southern Company Generation, Southern Company Generation and Energy Marketing
Pamela Hunter
Yes
The drafting team has identified the appropriate aggregation point for dispersed power producing resources.
Yes
The drafting team has identified the appropriate aggregation point for dispersed power producing resources.
The drafting team has identified the appropriate aggregation point for dispersed power producing resources.
Yes
Yes
No

Individual
Spencer
Tacke
No
For all three PRC-005 proposed modifications, I think we still need to replace the 75 MVA generator size requirement with the 20 MVA size requirement, for the following reasons: WECC requires dynamic model verification for all units 20 MVA or larger connected at voltages 60 kV and above. This is because WECC members have learned over the years to recognize the significant role that smaller size generators play in system response and stability. Also, the WECC MVWG (Modeling and Validation Work Group) is currently performing a study to determine what is the minimum size generator for which model testing and verification needs to be completed. Also, within the next few years, there will be thousands of MWs of PV solar plants on-line in Central California, a large percentage of which will be small, 20 MW plants. We see about 2,500 MW of 20 MW PV units in the queue for the SGIP, SGIP-TC, WDAT, Clusters 1&2, and Clusters 3&4 in California, all coming on-line between now and 2018. Also, past WECC studies over the years of major outages have shown that generators, and indeed loads, below 100 kV, have played a major role in the impact of outages. In fact, the most accurate duplication of the August 1996 outage, and more recent outages that the WECC MVWG has simulated, have shown that the accuracy of the simulated results of actual system outages is highly affected by the accuracy of the modeled system below 100 kV.
No
For all three PRC-005 proposed modifications, I think we still need to replace the 75 MVA generator size requirement with the 20 MVA size requirement, for the following reasons: WECC requires dynamic model verification for all units 20 MVA or larger connected at voltages 60 kV and above. This is because WECC members have learned over the years to recognize the significant role that smaller size generators play in system response and stability. Also, the WECC MVWG (Modeling and Validation Work Group) is currently performing a study to determine what is the minimum size generator for which model testing and verification needs to be completed. Also, within the next few years, there will be thousands of MWs of PV solar plants on-line in Central California, a large percentage of which will be small, 20 MW plants. We see about 2,500 MW of 20 MW PV units in the queue for the SGIP, SGIP-TC, WDAT, Clusters 1&2, and Clusters 3&4 in California, all coming on-line between now and 2018. Also, past WECC studies over the years of major outages have shown that generators, and indeed loads, below 100 kV, have played a major role in the impact of outages. In fact, the most accurate duplication of the August 1996 outage, and more recent outages that the WECC MVWG has simulated, have shown that the accuracy of the simulated results of actual system outages is highly affected by the accuracy of the modeled system below 100 kV.
No
For all three PRC-005 proposed modifications, I think we still need to replace the 75 MVA generator size requirement with the 20 MVA size requirement, for the following reasons: WECC requires dynamic model verification for all units 20 MVA or larger connected at voltages 60 kV and above. This is because WECC members have learned over the years to recognize the significant role that smaller size generators play in system response and stability. Also, the WECC MVWG (Modeling and Validation Work Group) is currently performing a study to determine what is the minimum size generator for which model testing and verification needs to be completed. Also, within the next few years, there will be thousands of MWs of PV solar plants on-line in Central California, a large percentage of which will be small, 20 MW plants. We see about 2,500 MW of 20 MW PV units in the queue for the SGIP, SGIP-TC, WDAT, Clusters 1&2, and Clusters 3&4 in California, all coming on-line between now and 2018. Also, past WECC studies over the years of major outages have shown that generators, and indeed loads, below 100 kV, have played a major role in the impact of outages. In fact, the most accurate duplication of the August 1996 outage, and more recent outages that the WECC MVWG has simulated, have shown that the accuracy of the simulated results of actual system outages is highly affected by the accuracy of the modeled system below 100 kV.
No
For both VAR-002 proposed modifications, I don't think we should state non-applicability of the Standard for dispersed generation resources identified through Inclusion 14 of the BES definition, for the following reasons: WECC requires dynamic model verification for all units 20 MVA or larger connected at voltages 60 kV and above. This is because WECC members have learned over the

years to recognize the significant role that smaller size generators play in system response and stability. Also, the WECC MVWG (Modeling and Validation Work Group) is currently performing a study to determine what is the minimum size generator for which model testing and verification needs to be completed. Also, within the next few years, there will be thousands of MWs of PV solar plants on-line in Central California, a large percentage of which will be small, 20 MW plants. We see about 2,500 MW of 20 MW PV units in the queue for the SGIP, SGIP-TC, WDAT, Clusters 1&2, and Clusters 3&4 in California, all coming on-line between now and 2018. Also, past WECC studies over the years of major outages have shown that generators, and indeed loads, below 100 kV, have played a major role in the impact of outages. In fact, the most accurate duplication of the August 1996 outage, and more recent outages that the WECC MVWG has simulated, have shown that the accuracy of the simulated results of actual system outages is highly affected by the accuracy of the modeled system below 100 kV.

No

For both VAR-002 proposed modifications, I don't think we should state non-applicability of the Standard for dispersed generation resources indentified through Inclusion I4 of the BES definition, for the following reasons: WECC requires dynamic model verification for all units 20 MVA or larger connected at voltages 60 kV and above. This is because WECC members have learned over the years to recognize the significant role that smaller size generators play in system response and stability. Also, the WECC MVWG (Modeling and Validation Work Group) is currently performing a study to determine what is the minimum size generator for which model testing and verification needs to be completed. Also, within the next few years, there will be thousands of MWs of PV solar plants on-line in Central California, a large percentage of which will be small, 20 MW plants. We see about 2,500 MW of 20 MW PV units in the queue for the SGIP, SGIP-TC, WDAT, Clusters 1&2, and Clusters 3&4 in California, all coming on-line between now and 2018. Also, past WECC studies over the years of major outages have shown that generators, and indeed loads, below 100 kV, have played a major role in the impact of outages. In fact, the most accurate duplication of the August 1996 outage, and more recent outages that the WECC MVWG has simulated, have shown that the accuracy of the simulated results of actual system outages is highly affected by the accuracy of the modeled system below 100 kV.

No

Individual

Sergio Banuelos

Tri-State Generation and Transmission Association, Inc.

Yes

4.2.5 is written strangely. "Protection Systems for the following BES generator Facilities not identified through Inclusion I4 of the BES definition" reads better.

Yes

4.2.5 is written strangely. "Protection Systems for the following BES generator Facilities not identified through Inclusion I4 of the BES definition" reads better.

Yes

4.2.5 is written strangely. "Protection Systems for the following BES generator Facilities not identified through Inclusion I4 of the BES definition" reads better.

Yes

Yes

"R7" should be "M6". The effective date is confusing as written and makes it seem as if the standard would be effective immediately. Was that the SDT's intentions? Since VAR-002-3 is still waiting on FERC approval and is not effective yet the industry should have some time to prepare for VAR-002-4.

No

Individual

Michael Moltane

ITC
Yes
Regarding VAR-002, ITC makes the following comments: The Standard should define dispersed power producing resource. While in a practical sense this is a facility comprised of wind turbines or PV inverters, offering exclusions from Requirements based on an undefined criteria is not a good practice. R4 – ITC recommends removal of the sub-bullet under R4 excluding the generators identified through Inclusion I4. The exclusion using BES I4 is confusing and may conflict with existing standard VAR-001-4. A non-BES unit or several non-BES units combined together could have an impact on the BES and thus removing the generators from VAR-002-4 R4 solely based on Inclusion I4 may be detrimental to reliability. Per VAR-001-4 R4, the TOP is required to specify criteria that will exempt generators from following a voltage or reactive power schedule and associated notification requirements. Therefore, ITC recommends that VAR-002-3 R4 should be reworded as “Unless exempted by the Transmission Operator, each Generator Operator shall notify its associated Transmission Operator within 30 minutes of becoming aware of a change in reactive capability due to factors other than a status change described in Requirement 3”. The TOP can determine what notifications are necessary and be more specific depending on the needs of the system or individual facility. For example, a TOP exemption criteria may contain: “Dispersed power producing facilities are exempt from reactive capability change notifications less than 10% of the total aggregate lagging reactive capability as measured at the POI at nominal voltage”. TOPs typically will not want to receive individual turbine outage notifications; however, there may be instances where a dispersed power producing resource could lose an individual unit that may affect reliable operations (i.e. large individual units). In addition, the sub-bullet language in VAR-002-4 may be interpreted such that generators not in BES are exempt from reactive capability notifications and, in turn, exempt from following schedules which may be in conflict with VAR-001-4 and potentially impact the reliability of the BES. VAR-001-4 requires the TOP to determine the exemption criteria for generators and ITC recommends that VAR-002-4 be consistent with this practice as the TOP may require non-BES generators to follow a voltage or reactive power schedule based on the collective impact to the BES. R5 – The language in VAR-002-4 R5 is a repeat of the VAR-002-4 R4 language and does not correspond to sub-requirement R5.1 . Replace with appropriate R5 language from VAR-002-3. Similar to R4, the exclusion shouldn’t be based on BES I4. ITC recommends the footnote is reworded to: “For dispersed power producing resources, this requirement applies only to those transformers that have at least one winding at the same or higher voltage as the lowest voltage Point of Interconnection location(s).”
Group
Bonneville Power Administration
Andrea Jessup
Yes
This approach relies on maintenance practices of individual generators and collector systems before reaching the aggregation points as provided by the generator owner. This is in their best interest and in the best interest of the industry.
Yes
This approach relies on maintenance practices of individual generators and collector systems before reaching the aggregation points as provided by the generator owner. This is in their best interest and in the best interest of the industry.
Yes
This approach relies on maintenance practices of individual generators and collector systems before reaching the aggregation points as provided by the generator owner. This is in their best interest and in the best interest of the industry.
Yes

Yes
No
Individual
Joe Tarantino
Sacramento Municipal Utility District
Yes
Please clarify whether Protection System Maintenance only applies to the aggregate transformers, but not the individual wind generators and its respective step-up transformers.
Yes
Yes
Yes
: Please clarify that Protection System Misoperations of the individual wind generators affects only themselves, but will not cause an aggregate effect with other wind turbines. For example, this standard only applies to aggregate substation transformers. There is a concern that still lies on meeting requirements R1 and R2, operating in voltage control mode. Some existing wind generators operate in a power factor control mode, not voltage control mode, and is not capable of operating in either voltage or power factor control mode.
Yes
Comment 1: These revisions are logical and simply needed to clarify applicability. In fact, not approving these revisions may be detrimental to reliability or not useful to the support of the reliable operation of the BES. Moreover, preparing for implementation under the chance the revisions are not approved is diverting time and resources that could otherwise be devoted to efforts that do contribute to the reliable operation of the BES. Comment 2: Please proceed expeditiously with these revisions and convey such urgency to the approving entities. Although the goal of this effort is to ensure these revisions are approved prior to the June 2016 effective date for newly identified elements under the BES definition, affected entities have no alternative but to expend resources and devote time to plan, prepare and begin compliance related activities well before June 2016.

Additional Comments:

AECI

Phil Hart

1. Do you agree with the revisions made in proposed PRC-005-2(X) to clarify applicability of PRC-005-2 to dispersed power producing resources included in the BES through Inclusion I4 of the BES definition? If not, please provide technical rationale for your disagreement along with suggested language changes.

Yes: X

Comments: Suggest removing "for generators" in 4.2.5, as this is redundant. Also suggest removing "the following" in 4.2.5, as the following is not a list of generators, but a list of Protection Systems. Suggested wording changes:

"The following Protection Systems for BES generator Facilities not identified through Inclusion I4 of the BES definition:"

2. Do you agree with the revisions made in proposed PRC-005-3(X) to clarify applicability of PRC-005-3 to dispersed power producing resources included in the BES through Inclusion I4 of the BES definition? If not, please provide technical rationale for your disagreement along with suggested language changes.

Yes: X

Comments: The same comments provided to question 1 also apply to question 2.

3. Do you agree with the revisions made in proposed PRC-005-X(X) to clarify applicability of PRC-005-X (the version of PRC-005 containing revisions to address Sudden Pressure relays, being developed in Project 2007-17.1) to dispersed power-producing resources included in the BES through Inclusion I4 of the BES definition? If not, please provide technical rationale for your disagreement along with suggested language changes.

Yes: X

Comments: The same comments provided to question 1 also apply to question 3.

4. Do you agree with the revisions made in proposed VAR-002-2b(X) to clarify applicability of VAR-002-2b to dispersed power producing resources included in the BES through Inclusion I4 of the BES definition? If not, please provide technical rationale for your disagreement along with suggested language changes.

Yes: X

5. Do you agree with the revisions made in proposed VAR-002-4 to clarify applicability of VAR-002-3 to dispersed power producing resources included in the BES through Inclusion I4 of the BES definition? If not, please provide technical rationale for your disagreement along with suggested language changes.

Yes:

Comments: The bullet describing the DGR exclusion for R4 lacks identification of what "individual" is being excluded, and as written could create confusion. The rationale states the intent is to exclude the individual resources from R4. Suggested revised bullet: "Reporting of reactive capability changes is not applicable to the individual resource for dispersed power producing resources identified through Inclusion I4 of the Bulk Electric System Definition." The bullet used in VAR-002-2b(X) could also be used here, however it lacks specificity.

6. Do you have any additional comments to assist the DGR SDT in further developing its recommendations?

Yes:

No: X

Consideration of Comments

Project 2014-01 Applicability for Dispersed Generation Resources Standards

The Dispersed Generation Resources (DGR)¹ Standards Drafting Team (SDT) thanks all commenters who submitted comments on the standards. These standards were posted for a 45-day public comment period from June 12, 2014 to July 28, 2014. Stakeholders were asked to provide feedback on the standards and associated documents through a special electronic comment form. There were 36 sets of comments, including comments from approximately 127 different people from approximately 89 companies representing all 10 Industry Segments as shown in the table on the following pages.

All comments submitted may be reviewed in their original format on the standard's [project page](#).

This document contains the SDT's response to all industry comments received during this comment period. The SDT encourages commenters to review its responses to ensure all concerns have been addressed. The SDT notes that a significant majority of commenters agree with the SDT's recommendations on these standards, but that several commenters expressed specific concerns. Some comments supporting the SDT's recommendations are discussed below but in most cases are not specifically addressed in this response. Also, several comments in response to specific questions are duplicated in other questions, and several commenters raise substantively the same concerns as others. Therefore, the SDT's consideration of all comments is addressed in this section in summary form, with duplicate comments treated as a single issue.

1. Summary Consideration

Industry overwhelmingly agrees with the SDT's recommendations to make applicability changes or provide guidance to account for the unique characteristics of DGRs in the NERC PRC-005 and VAR-002 standards as evidenced by the initial ballot results. However, there are some disagreements among stakeholders and typographical errors contained in and illuminated by industry comments. The SDT has carefully reviewed and considered each stakeholder comment and has revised its recommendations where suggested changes are consistent with SDT intent and industry consensus. The SDT's consideration of all comments follows.

2. General Comments

Industry identified a number of typographical and formatting errors in each of the posted high-priority standards PRC-005-2(X), PRC-005-3(X), PRC-005-X(X), VAR-002-2b(X), and VAR-002-4. The SDT also identified additional typographical and formatting errors during its most recent review. The SDT has

¹ The terms "dispersed generation resources" and "dispersed power producing resources" are used interchangeably.

corrected each identified typographical and formatting error as reflected in the posted redlined standards.

Some commenters object to including standard language in bullet format. At least one commenter believes that bullet points are historically described as “OR” statements in NERC Reliability Standards. The SDT is unaware of any drafting requirement that compels it to equate bullet points to “or” statements, and its use of the bullet format is consistent with guidance from NERC staff. In the absence of industry consensus or guidance from NERC staff that supports eliminating the bullet format, the SDT respectfully declines to adopt that suggestion.

At least one commenter notes that in Quebec, the RTP (Main Transmission System) Elements are applied instead of Bulk Electric System (BES) Elements, and that the Generation Facilities are greater than 50 MVA / 44kV instead of 75 MVA. The commenter also notes that in Quebec, no DGRs are connected into the RTP network. The commenter believes that to facilitate compliance, the expression “inclusion I4” should not be included in the standard.

The SDT recognizes that in certain regions there may be additional regional standards and requirements that result in different criteria and thresholds in determining the requirements for Generation Facilities, including those facilities with DGRs. While the SDT intends to provide recommendations on these regional specific standards, making modifications to these standards and their requirements is outside the scope of this project. With respect to the application of the standard under various Canadian provincial and federal regulatory frameworks, the SDT recognizes that certain Canadian provinces have a process to adopt or modify NERC standards for use and enforcement in their specific provinces, and all have discretion to approve and enforce standards according to the needs within their jurisdictions. Therefore, the SDT respectfully declines to adopt this suggestion as inconsistent with its charge, which is specifically to make changes to standards to account for the explicit inclusion of dispersed generation resources under Inclusion I4 of the definition of BES.

3. Recommended Applicability Changes to PRC-005

Several commenters made comments that apply to all DGR versions of the posted PRC-005 standard, which the SDT addresses in this section. Although the SDT addresses industry comments specific to particular versions in the following sections, it considered each comment in the context of all versions of that particular standard to the extent applicable.

At least one commenter asks that the SDT explicitly state in the standard that PRC-005 becomes applicable on facilities where the aggregate generation sums to greater than 75 MVA and it connects at greater than 100 kV, and reference the BES Definition Reference document to clearly identify the applicable facilities where the aggregate generation sums to greater than 75 MVA and it connects at greater than 100 kV.

The BES Definition reference document is intended for use by entities in conjunction with the various reliability standards and their requirements in determining the applicability to their particular facilities. The proposed wording provided by the commenter is included within the BES Definition, which should be used by entities in determining applicability of PRC-005 to their facilities. The Protection Systems applied on the blue busses in figures I4-1 thru I4-4 of the BES Definition Reference Document are intended to be included in the applicable Facilities of the proposed revisions to PRC-005. For inclusion I4 facilities, the owner of the aggregating Facilities that are within scope of the proposed revisions to PRC-005 are responsible for maintaining per the standards requirements, irrespective of whether one or more entities own the various facilities connected. A sub transmission line used in the aggregation of dispersed generation would be within scope of the proposed revision to PRC-005 if the aggregate nameplate generation connected is greater than 75 MVA and the sub-transmission is designed primarily for delivering this generation capacity to a common point of connection at a voltage of 100 kV or above. The SDT respectfully declines to adopt the commenter's recommendations.

At least one commenter suggests that for consistency PRC-004 and PRC-005 should be applicable at an aggregate of greater than or equal to 75 MVA of BES facilities. The SDT recognizes the need to address protection system Misoperations at levels below the aggregate 75 MVA in some instances and has delineated these instances in PRC-004. The SDT believes the proposed "differences" in applicability for PRC-004 and PRC-005 are warranted and that the SDT has provided sufficient technical justification for this approach. Moreover, industry consensus clearly supports the SDT's recommendations on PRC-005. Therefore, the SDT respectfully declines to adopt this suggestion.

At least one commenter advocates replacing the 75 MVA generator size requirement with a 20 MVA size requirement citing a number of factors specific to the WECC region. In order to provide consistent requirements for all generation, the SDT believes it is necessary to assess applicability on individual units greater than 20 MVA and aggregate generation greater than 75 MVA, which are thresholds that have been explicitly recognized and approved by FERC as an appropriate threshold for these types of facilities consistent with the revised BES definition.² The SDT therefore does not believe it would be appropriate or technically justifiable to use different aggregation thresholds. The SDT notes that regional requirements may be more stringent than the national standards upheld through NERC and that all entities will need to abide by the applicable region's requirements. Moreover, this position is supported by clear industry consensus. For these reasons, the SDT respectfully declines to adopt this minority position.

At least one commenter believes Inclusion I4 of the BES definition specifically includes each generating resource, and that it is inconsistent to not include them for testing the protection systems under PRC-005. As written, according to the commenter, there would be portions of the BES that would not be

² See FERC Order Approving Revised Definition, P 20, Docket No. RD14-2-000.

required to have the protection systems tested. The commenter believes that a GO with a plant of small units aggregating above 75 MVA would be required to test the protection systems on all their units.

The SDT's scope was to review the applicability of a number of NERC standards as they apply to DGRs and determine if the standard requirements were appropriate. The SDT asserts that relay maintenance on individual units would not provide a significant reliability benefit to the BES and therefore should remain at the discretion of the entity as opposed to a NERC-enforced requirement. Industry consensus supports the SDT's position on this standard. Moreover, it is not within the scope of this project to evaluate the applicability of these standards to non-dispersed power producing resources, including the example of the GO with a plant of small units aggregating above 75 MVA stated by the commenter. For these reasons, the SDT respectfully declines to adopt the commenter's position.

At least one commenter believes that under the standard, a conventional generating resource has to have a documented protection maintenance program which it must follow to ensure reliability, while under the proposed revisions to the standard, a similarly-sized, DGR would not be required to do the same. According to the commenter, if the standard is not applied to the DGR, then there is no required protection maintenance, which can result in more frequent trips and degraded reliability. The commenter believes that loss of the DGRs as distinct from individual units would have the same impact as loss of a single, similarly sized conventional generating resource, and thus a maintenance program that applies beyond the common point of connection should be required. The commenter believes that the maintenance program should be tailored to the type of DGR as determined by the GO/GOP, but having no requirement in place does not ensure reliable operations.

The SDT believes that the proposed language does require a DGR to have a protection system maintenance plan for the Facilities from the point where those resources aggregate to 75 MVA through to a common point of interconnection at or above 100 kV. In light of clear industry consensus supporting the SDT's recommendations, the SDT respectfully declines to make additional revisions to address this minority concern.

A. PRC-005-2(X)

At least one commenter believes that in order to minimize confusion regarding the use of the term "Facilities" versus "facilities" in the Applicability Section, the SDT should change the heading of 4.2 to "Applicable facilities." The commenter also suggests that the formatting in 4.2.6 parallel the formatting of 4.2.5 in that specifics are listed in 4.2.5 and they are absent in 4.2.6, or modify 4.2.5 to match 4.2.6. Other commenters raise similar consistency concerns.

The SDT intends to refer to "Facilities" in the applicability section; this applicability section and the term "Facilities" is used in a number of standards to describe specific equipment that the standards'

requirements should be applied to. The scope of this SDT is to address the applicability to DGRs only, and the SDT feels that changing this section to “facilities” would go beyond the scope of this project. The SDT chose not to list the specific Protection Systems in 4.2.6 like they are listed in 4.2.5, as the SDT believed the language in 4.2.6.1 (i.e., “. . . Facilities used in aggregating dispersed. . .”) will result in inclusion of the appropriate Protection Systems for DGR facilities. The SDT also believes the current language is adequate and provides for a clear separation between the requirements for inclusion I4 generators and the requirements for all other BES generators. Consistent with clear industry consensus supporting the SDT’s direction on this issue, the SDT respectfully declines to adopt the proposed changes.

At least one commenter believes that in 4.2.6.1, “75 MVA should be changed to “20 MVA.” The commenter believes this would make it comparable to I2 generators, and that although the change to 20 MVA would have this standard apply to non-BES assets, many standards do likewise. The commenter notes that “Protection Systems,” which are the subject of this standard, are non-BES. The commenter believes that as written, a reliability gap would be created between I4 generators and I2 generators. According to the commenter, the proposed change violates Section 303 of the NERC Rules of Procedure, paragraph 1 that states: “Competition - A Reliability Standard shall not give any market participant an unfair competitive advantage.”

In order to provide consistent requirements for all generation, the SDT believes it is necessary to assess applicability on individual units greater than 20 MVA and aggregate generation greater than 75 MVA, which are thresholds that have been explicitly recognized and approved by FERC as appropriate thresholds for these types of facilities consistent with the revised BES definition.³ The SDT therefore does not believe it would be appropriate to use different aggregation thresholds absent a robust technical justification to do so. Moreover, the SDT does not believe that a reliability gap is created, nor any unfair competitive advantages are given as a result, a position that is supported by clear industry consensus supporting the SDT’s direction on these standards. Absent a clear technical justification compelling such a change, the SDT, after consulting with NERC’s legal representative assigned to the project, respectfully declines to adopt the commenter’s suggestion.

At least one commenter recommends revising 4.2.5 to read “Protection Systems for the following BES generator Facilities identified through Inclusions I2 and I3 of the BES definition,” as the commenter believes it is more appropriate to cite how these BES generators are included under this section as opposed to indicating how they are not applicable under this section. Currently, according to the commenter, the standard’s applicability is based first on the NERC Registration Criteria and secondly on facilities identified within the standard, regardless of their BES status. The commenter believes the proposed revisions mean to change the applicability of the standard first to the NERC Registration Criteria and secondly on facilities identified within the standard, and this BES generator Facilities

³ See FERC Order Approving Revised Definition, P 20, Docket No. RD14-2-000.

change in 4.2.5 (i.e. Inclusions I2 and I3) essentially means the Protection System to be considered now is the “generator including the generator terminals through the high-side of the step-up transformer” and no longer considers protection to the point of interconnection.

The SDT believes the current language is adequate and clear. The SDT chose to use Inclusion I4 in the revised language of 4.2.5 such that the section 4.2.5 would resemble as closely as possible the original language of 4.2.5. Introducing the I2 and I3 terminology into this language was considered but determined to be unnecessary in order to specifically address DGRs. Furthermore, the SDT believes that further clarification of the applicability of the standard requirements to BES generators that are not identified under Inclusion I4 generators is beyond the scope of this project. The SDT disagrees that the revised language results in exclusion of the protection at the point of interconnection for these facilities, as this protection would be covered under 4.2.6.1. The SDT’s position is supported by clear industry consensus and it therefore respectfully declines to make the proposed changes.

B. PRC-005-3(X)

At least one commenter recommends revising 4.2.5 to read “Protection Systems for the following BES generator Facilities identified through Inclusions I2 and I3 of the BES definition,” as the commenter believes it is more appropriate to cite how these BES generators are included under this section as opposed to indicating how they are not applicable under this section.

The SDT believes the current language is adequate. The SDT chose to use Inclusion I4 in the revised language of 4.2.5 such that the section 4.2.5 would resemble as closely as possible the original language of 4.2.5. Introducing the I2 and I3 terminology into this language was considered, but determined to be unnecessary in order to specifically address dispersed power producing resources. The SDT believes that further clarification of the applicability of the standard requirements to BES generators that are not identified under Inclusion I4 generators is beyond the scope of this project.

At least one commenter believes that in order to minimize confusion regarding the use of the term “Facilities” versus “facilities” in the Applicability Section, the SDT should change the heading of 4.2 to “Applicable facilities.” The commenter also suggests that the formatting in 4.2.6 parallel the formatting, or construction, of 4.2.5 in that specifics are listed in 4.2.5 and they are absent in 4.2.6, or modify 4.2.5 to match 4.2.6. Another commenter believes that PRC-005-3(X) facilities sections (4.2.6 and 4.2.6.1) should be clarified and consistent with section 4.2.5 and offers suggested language to enhance clarity.

The SDT intends to refer to “Facilities” in the applicability section; this applicability section and the term “Facilities” is used in a number of standards to describe specific equipment that the standards’ requirements should be applied to. The scope of this SDT is to address the applicability to dispersed power producing resources only, and the SDT feels that changing this section to “facilities” would go

beyond the scope of this project. The SDT chose not to list the specific Protection Systems in 4.2.6 like they are listed in 4.2.5, as the SDT believed the language in 4.2.6.1 (i.e., “. . . Facilities used in aggregating dispersed. . .”) will result in inclusion of the appropriate Protections Systems for dispersed power producing facilities, a position supported by clear industry consensus. Therefore, the SDT respectfully declines to change its position.

C. PRC-005-X(X)

At least one commenter recommends revising 4.2.5 to read “Protection Systems for the following BES generator Facilities identified through Inclusions I2 and I3 of the BES definition,” as the commenter believes it is more appropriate to cite how these BES generators are included under this section as opposed to indicating how they are not applicable under this section.

The SDT believes the current language is adequate. The SDT chose to use Inclusion I4 in the revised language of 4.2.5 such that the section 4.2.5 would resemble as closely as possible the original language of 4.2.5. Introducing the I2 and I3 terminology into this language was considered, but determined to be unnecessary in order to specifically address dispersed power producing resources. The SDT believes that further clarification of the applicability of the standard requirements to BES generators that are not identified under Inclusion I4 generators is beyond the scope of this project.

At least one commenter asks whether the reference to PRC-005-3 in the second line under the Description of Current Draft should be to PRC-005-4. The commenter notes that the redline version shows a rationale box with the Introduction section, and that this box, even though it contains redline changes, is not included in the clean version.

The reference to PRC-005-3 in the Description of Current Draft section is intended, as no released version of PRC-005-4 existed at the time of the posting of this project (2014-01). Upon further review, all rationale boxes in the redline version were incorporated into the clean version of the standard as well.

At least one commenter questions whether the omission of sudden pressure relays for dispersed generation resources under PRC-005-X Applicability 4.2.6 was intentional. It was not the intent of the SDT to omit sudden pressure relays on aggregating equipment at facilities with DGRs from the requirements listed in PRC-005-X. The SDT believes that sudden pressure relays utilized on Facilities associated with DGRs should be treated the same as those used on Facilities of other BES generators. The SDT will provide these comments to Project 2007-17.3 for consideration.

At least one commenter believes that sudden pressure relays are not “necessary.” The scope of this SDT is to address the applicability to dispersed power producing resources only, not whether there is technical justification to include or exclude sudden pressure relays as a Protection System within the

scope of PRC-005. The SDT believes that sudden pressure relays used on Facilities associated with DGRs should be treated the same as those used on Facilities of other BES generators. The SDT will provide these comments to Project 2007-17.3 for consideration.

4. Recommended Applicability Changes to VAR-002

Several commenters made comments that apply to both DGR versions of the posted VAR-002 standard, which the SDT addresses in this section. Although the SDT addresses industry comments specific to particular versions in the following sections, it considered each comment in the context of all versions of that particular standard to the extent applicable.

At least one commenter believes that the proposed changes are not consistent with the delineation in PRC-004 and PRC-005 nor inclusive of the DGR issue, and that VAR-002 changes only address change in reactive capability and do not address automatic voltage control and status at each generator site. The commenter suggests that VAR-002 should be written explicitly to only apply at the point of aggregation to 75 MVA with the transmission system.

The SDT is unaware of an automatic voltage control and status at each generator site issue. The SDT has proposed to exempt reporting of status or capability changes as stated in Requirement R3.1. to the DGR individual generating units identified through Inclusion I4 of the BES definition, but did not propose exemption from reporting at the aggregate facility level.

At least one commenter believes proposed R3 creates a reliability gap between I4 generators and I2 generators, and violates Section 303 of the NERC Rules of Procedure. The commenter suggests modifying the language to create a 20 MVA aggregation threshold for reporting. The SDT carefully considered this issue in responding to comments on its White Paper and these standards, and industry consensus clearly supports the SDT's recommendations on this standard, including Requirement R3. Absent clear industry consensus supporting the commenter's suggestion to modify the SDT's recommendations on VAR-002, the SDT has consulted with the NERC legal representative assigned to the project and respectfully declines to adopt the commenter's recommendation.

At least one commenter does not believe VAR-002 should state non-applicability to DGRs identified through Inclusion I4 of the BES definition and cites a number of factors specific to the WECC region, particularly with respect to modeling. The SDT agrees that modeling should be improved and inclusive of DGR facilities. However, VAR-002 deals with reporting of reactive power capability changes. Therefore, in light of clear industry consensus supporting the SDT's direction on VAR-002, the SDT respectfully declines to adopt the commenter's suggestion.

A. VAR-002-2b(X) [Note that FERC approved VAR-002-3 on August 1, 2014, and VAR-002-2b will be retired effective at midnight on September 30, 2014. The SDT is proceeding with balloting of

VAR-002-2b(X) because of differences in the way standards become enforceable in certain Canadian jurisdictions. The intent if VAR-002-2b(X) is approved by balloters is to file it upon Board adoption only in those Canadian jurisdictions that do not tie their enforcement dates to FERC approval.]

At least one commenter asks the SDT to clarify that Protection System Misoperations of the individual wind generators affects only themselves, but will not cause an aggregate effect with other wind turbines. For example, the commenter notes, this standard only applies to aggregate substation transformers. The commenter is concerned that still lies on meeting Requirements R1 and R2, operating in voltage control mode, and that some existing wind generators operate in a power factor control mode, not voltage control mode, and is not capable of operating in either voltage or power factor control mode.

The SDT believes Requirement R1 provides an exemption by the Transmission Operator, such as when “automatic voltage regulator” (AVR) is not required for older DGR facilities. Similarly, Requirement R2 has an exemption clause by the Transmission Operator. It is implied in NERC VAR-001-3 that each GOP and TOP should understand capabilities of the generation facility, including the equipment installed, said equipment’s capabilities and the requirements of the transmission system to ensure a mutually agreeable solution and schedule are used.

At least one commenter notes that references to R4 and R5 in the Description of Current Draft Section should be to R3 and R4, and recommends deleting “BES” in front of “Bulk Electric Systems” referenced in the line in which the references are made. The SDT agrees and has therefore adopted these suggestions. The SDT believes the current language is sufficiently clear, and industry consensus supports the SDTs direction on this issue. Therefore, the SDT respectfully declines to adopt the commenter’s suggestion.

At least one commenter suggests that the SDT modify R1 reasoning that each individual generating unit of a dispersed generation site that exceeds the 75 MVA threshold is included as part of the BES, and R1 would apply requiring each of these units to be operated with AVR in voltage regulating mode. According to the commenter, these units usually do not have an AVR and are not capable of controlling voltage; rather, they rely on other voltage regulating equipment such as SVC or capacitor banks to control voltage at the interconnecting point. Thus, the commenter requests that the SDT modify R1 so that is not applicable to the individual DGR units. The SDT believes the current language is sufficiently clear, and industry consensus supports the SDTs direction on this issue. Therefore, the SDT respectfully declines to adopt the commenter’s suggestion.

At least one commenter believes R2 should also be modified to reflect that these DGRs often do not have AVRs and must rely on other voltage regulating equipment to control voltage at the

interconnecting point, and that the SDT should modify R2 so that is not applicable to the individual DGR units.

The SDT does not agree that additional applicability changes are required for Requirements R1 and R2 because the AVR portion of the requirements cannot be applied to individual generators that do not have AVRs at each individual unit. Furthermore, each generation facility may have a different methodology to ensure the facility has an automatic and dynamic response to changes in voltage to ensure the TOPs instructions are maintained. It is implied in NERC VAR-001-3 that each GOP and TOP should understand the capabilities of the generation facility including the equipment installed, equipment capabilities, and the requirements of the transmission system to ensure that a mutually agreeable solution and schedule are used. Industry consensus supports the approach recommended by the SDT, and the SDT therefore respectfully declines to adopt the suggested changes to Requirements R1 and R2.

The SDT agrees with commenters that additional clarity is warranted in Requirement R3 and has therefore proposed changes as reflected in the posted redlined standard.

Some commenters agree with the SDTs recommended changes to Requirement R3, Part 3.1 but expresses their view that the number of individual units in an aggregated site is not detrimental to the overall operation of the entire site. In that case, according to the commenters, the site status for the entire aggregated facility should be reported. Many commenters further note that the Rationale Box for Footnote 5 references the Transmission Provider and in one instance only references Transmission, and that these references should be to the Transmission Planner as indicated in Requirement R4.

It was not the intent of the SDT to change the reporting requirements at the aggregate facility level. However, the SDT has made changes to the Requirement language to enhance clarity of the applicability to dispersed power producing resources. The SDT agrees the rationale for Requirement R4 should reference Transmission Operator and Transmission Planner and has therefore adopted that suggestion as reflected in the posted redlined standard.

At least one commenter agrees with the proposed Requirements but has issues with the associated Rationale for Footnote 5 in Requirement R4, Part 4.1. The commenter believes auxiliary transformers stated in Requirement R4.1 are usually transformers that provide station services to the generator, and that the second sentence is out of line since it is directed to the collector system (34.5kV), which should be deleted. Another commenter suggests the SDT change "Transmission Provider" to "Transmission Planner." The SDT agrees and has therefore made clarifying changes to the rationale box as reflected in the posted redlined standard.

At least one commenter argues that since the standard is being revised the SDT should make changes to re-align the Measures with the Requirements to develop a more risk-based standard as NERC has

proposed going forward. The SDT expresses no opinion on this point, as the suggested change is outside the scope of this project.

B. VAR-002-4

At least one commenter notes that the bullet describing the DGR exclusion for R4 lacks identification of what “individual” is being excluded, and as written could create confusion. The commenter further notes that the rationale box indicates that the intent is to exclude the individual resources from R4, and suggests the following modification: “Reporting of reactive capability changes is not applicable to the individual resource for dispersed power producing resources identified through Inclusion I4 of the Bulk Electric System Definition.” The SDT believes that changes it has proposed in the posted redlined version of this standard are sufficiently clear.

At least one commenter believes the bulleted item under R4 is too wordy and recommends alternative language to provide clarity. The SDT has made clarifying changes as reflected in the posted redlined standard.

At least one commenter suggests inserting the term “generator” between “individual” and “for” in the bullet under Requirement R4. Another commenter notes that the rationale for R5 should identify the “Transmission Provider” to “Transmission Planner.” The SDT agrees and has therefore made clarifying changes as reflected in the posted redlined standard.

Several commenters identify several errors in the posted version of this standard, specifically, Requirements R4 and R5. The SDT is aware the balloted version of VAR-002-4 was missing language in Requirement R4 and changed the requirement language in Requirement R5. The SDT has corrected these errors as reflected in the posted redlined standard.

At least one commenter believes that since VAR-002-4 only contains minor technical revisions dealing with the applicability specifically for Requirements R4 and R5, it may be feasible that VAR-002-4 will be approved before VAR-002-3, and the special provisions for ‘the later of’ are therefore not needed. The commenter believes the traditional Effective Date language would suffice. The commenter also believes that the concept of ‘the first day of the first calendar quarter following approval’ needs to be added to the governmental approval clause.

The SDT worked in close consultation with NERC staff to develop language that would result in DGR applicability changes as quickly as reasonably practicable regardless of which versions are first approved by FERC. Indeed, although FERC has approved VAR-002-3 and the standard will become enforceable in the U.S. on October 1, 2014, the Effective date language must allow for the different frameworks by which standards become enforceable in Canadian provinces. The SDT therefore respectfully declines to adopt the commenter’s recommendation.

If you feel that your comment has been overlooked, please let us know immediately. Our goal is to give every comment serious consideration in this process. If you feel there has been an error or omission, you can contact the Director of Standards, Valerie Agnew, at 404-446-2566 or at valerie.agnew@nerc.net. In addition, there is a NERC Reliability Standards Appeals Process.⁴

⁴ The appeals process is in the Standard Processes Manual: http://www.nerc.com/comm/SC/Documents/Appendix_3A_StandardsProcessesManual.pdf

1. Do you agree with the revisions made in proposed PRC-005-2(X) to clarify applicability of PRC-005-2 to dispersed power producing resources included in the BES through Inclusion I4 of the BES definition? If not, please provide technical rationale for your disagreement along with suggested language changes.21

2. Do you agree with the revisions made in proposed PRC-005-3(X) to clarify applicability of PRC-005-3 to dispersed power producing resources included in the BES through Inclusion I4 of the BES definition? If not, please provide technical rationale for your disagreement along with suggested language changes.28

3. Do you agree with the revisions made in proposed PRC-005-X(X) to clarify applicability of PRC-005-X (the version of PRC-005 containing revisions to address Sudden Pressure relays, being developed in Project 2007-17.1) to dispersed power-producing resources included in the BES through Inclusion I4 of the BES definition? If not, please provide technical rationale for your disagreement along with suggested language changes33

4. Do you agree with the revisions made in proposed VAR-002-2b(X) to clarify applicability of VAR-002-2b to dispersed power producing resources included in the BES through Inclusion I4 of the BES definition? If not, please provide technical rationale for your disagreement along with suggested language37

5. Do you agree with the revisions made in proposed VAR-002-4 to clarify applicability of VAR-002-3 to dispersed power producing resources included in the BES through Inclusion I4 of the BES definition? If not, please provide technical rationale for your disagreement along with suggested language changes43

6. Do you have any additional comments to assist the DGR SDT in further developing its recommendations?.....49

The Industry Segments are:

- 1 — Transmission Owners
- 2 — RTOs, ISOs
- 3 — Load-serving Entities
- 4 — Transmission-dependent Utilities
- 5 — Electric Generators
- 6 — Electricity Brokers, Aggregators, and Marketers
- 7 — Large Electricity End Users
- 8 — Small Electricity End Users
- 9 — Federal, State, Provincial Regulatory or other Government Entities
- 10 — Regional Reliability Organizations, Regional Entities

Group/Individual		Commenter	Organization	Registered Ballot Body Segment									
				1	2	3	4	5	6	7	8	9	10
1.	Group	Guy Zito	Northeast Power Coordinating Council										X
Additional Member		Additional Organization	Region	Segment Selection									
1.	Alan Adamson	New York State Reliability Council, LLC	NPCC										
2.	David Burke	Orange and Rockland Utilities Inc.	NPCC	3									
3.	Greg Campoli	New York Independent System Operator	NPCC	2									
4.	Sylvain Clermont	Hydro-Quebec TransEnergie	NPCC	1									
5.	Chris de Granfenried	Consolidated Edison Co. of New York, Inc.	NPCC	1									
6.	Gerry Dunbar	Northeast Power Coordinating Council	NPCC	10									
7.	Mike Garton	Dominion Resources Services, Inc.	NPCC	5									
8.	Ben Wu	Orange and Rockland Utilities Inc.	NPCC	1									
9.	Mark Kenny	Northeast Utilities	NPCC	1									

Group/Individual	Commenter	Organization	Registered Ballot Body Segment																	
			1	2	3	4	5	6	7	8	9	10								
10. Peter Yost	Consolidated Edison Co. of New York, Inc.	NPCC	3																	
11. Helen Lainis	Independent Electricity System Operator	NPCC	2																	
12. Michael Jones	National Grid	NPCC	1																	
13. Silvia Parada Mitchell	NextEra Energy, LLC	NPCC	5																	
14. Bruce Metruck	New York Power Authority	NPCC	6																	
15. Alan MacNaughton	New Brunswick Power Corporation	NPCC	9																	
16. Lee Pedowicz	Northeast Power Coordinating Council		10																	
17. Robert Pellegrini	the United Illuminating Company		1																	
18. Ayesha Sabouba	Hydro One Networks Inc.		1																	
19. Brian Robinson	Utility Services		8																	
20. David Ramkalawan	Ontario Power Generation, Inc.		5																	
21. Si Truc Phan	Hydro-Quebec TransEnergie	NPCC	1																	
22. Brian Shanahan	National Grid	NPCC	1																	
23. Wayne Sipperly	New York Power Authority	NPCC	5																	
2.	Group	Janet Smith	Arizona Public Service Company	X		X		X	X											
N/A																				
3.	Group	Joseph DePoorter	MRO NSRF	X	X	X	X	X	X											
	Additional Member	Additional Organization	Region	Segment Selection																
1.	Amy Casucelli	Xcel Energy	MRO	1, 3, 5, 6																
2.	Chuck Wicklund	Otter Tail Power Company	MRO	1, 3, 5																
3.	Dan Inman	Minnkota Power Cooperative	MRO	1, 3, 5, 6																
4.	Dave Rudolph	Basin Electric Power Cooperative	MRO	1, 3, 5, 6																
5.	Kayleigh Wilkerson	Lincoln Electric System	MRO	1, 3, 5, 6																
6.	Jodi Jensen	WAPA	MRO	1, 6																
7.	Joseph DePoorter	Madison Gas & Electric	MRO	3, 4, 5, 6																
8.	Ken Goldsmith	Alliant Energy	MRO	4																
9.	Mahmood Safi	Omaha Public Power District	MRO	1, 3, 5, 6																
10.	Marie Knox	MISO	MRO	2																
11.	Mike Brytowski	Great River Energy	MRO	1, 3, 5, 6																
12.	Randi Nyholm	Minnesota Power	MRO	1, 5																
13.	Scott Nickels	Rochester Public Utiliteis	MRO	4																

Group/Individual	Commenter	Organization	Registered Ballot Body Segment											
			1	2	3	4	5	6	7	8	9	10		
14. Terry Harbour	MidAmerican Energy	MRO	1, 3, 5, 6											
15. Tom Breene	Wisconsin Public Service	MRO	3, 4, 5, 6											
16. Tony Eddleman	Nebraska Public Power District	MRO	1, 3, 5											
4.	Group	Connie Lowe	Dominion	X		X		X		X				
Additional Member Additional Organization Region Segment Selection														
1.	Randi Heise		MRO	NA										
2.	Mike Garton		NPCC	5										
3.	Louis Slade		RFC	5, 6										
4.	Larry Nash		SERC	1, 3, 5, 6										
5.	Group	Michael Lowman	Duke energy	X		X		X	X					
Additional Member Additional Organization Region Segment Selection														
1.	Doug Hils		RFC	1										
2.	Lee Schuter		FRCC	3										
3.	Dale Goodwine		SERC	5										
4.	Greg Cecil		RFC	6										
6.	Group	Kathleen Black	DTE Electric			X	X	X						
Additional Member Additional Organization Region Segment Selection														
1.	Kent Kujala	NERC Compliance	RFC	3										
2.	Daniel Herring	NERC Training & Standards Development	RFC	4										
3.	Mark Stefaniak	Generation Optimization	RFC	5										
4.	Barbara Holland	SOC												
5.	Dave Szulczewski	DE-EE Relay Eng Supv												
7.	Group	Cindy Stewart	FirstEnergy	X		X	X	X	X					
Additional Member Additional Organization Region Segment Selection														
1.	William Smith	FirstEnergy Corp	RFC	1										
2.	Doug Hohlbaugh	Ohio Edison	RFC	4										
3.	Ken Dresner	FirstEnergy Solutions	RFC	5										
4.	Kevin Querry	FirstEnergy Solutions	RFC	7										
8.	Group	David Greene	SERC Protection and Controls Subcommittee											

Group/Individual	Commenter	Organization	Registered Ballot Body Segment									
			1	2	3	4	5	6	7	8	9	10
Additional Member Additional Organization Region Segment Selection												
1.	Bridget Coffman	Santee Cooper										
2.	John Miller	GTC										
3.	George Pitts	TVA										
4.	Joel Masters	SCE&G										
5.	Steve Edwards	Dominion										
6.	David Greene	SERC										
7.	Paul Nauert	Ameren										
9.	Group	Carol Chinn	Florida Municipal Power Agency	X		X	X	X	X			
Additional Member Additional Organization Region Segment Selection												
1.	Tim Beyrle	City of New Smyrna Beach	FRCC	4								
2.	Jim Howard	Lakeland Electric	FRCC	3								
3.	Greg Woessner	Kissimmee Utility Authority	FRCC	3								
4.	Lynne Mila	City of Clewiston	FRCC	3								
5.	Cairo Vanegas	Fort Pierce Utility Authority	FRCC	4								
6.	Randy Hahn	Ocala Utility Service	FRCC	3								
7.	Stanley Rzad	Keys Energy Services	FRCC	4								
8.	Don Cuevas	Beaches Energy Services	FRCC	1								
9.	Mark Schultz	City of Green Cove Springs	FRCC	3								
10.	Tom Reedy	Florida Municipal Power Pool	FRCC	6								
11.	Steve Lancaster	Beaches	FRCC	1								
12.	Richard Bachmeier	Gainesville Regional Utilities	FRCC	1								
13.	Mike Blough	Kissimmee Utility Authority	FRCC	5								
10.	Group	Robert Rhodes	SPP Standards Review Group		X							
Additional Member Additional Organization Region Segment Selection												
1.	Stephanie Johnson	Westar Energy	SPP	1, 3, 5, 6								
2.	Bo Jones	Westar Energy	SPP	1, 3, 5, 6								
3.	Tiffany Lake	Westar Energy	SPP	1, 3, 5, 6								
4.	Ron Losh	Southwest Power Pool	SPP	2								
5.	Shannon Mickens	Southwest Power Pool	SPP	2								

Group/Individual		Commenter	Organization	Registered Ballot Body Segment									
				1	2	3	4	5	6	7	8	9	10
6. Wes Mizzell		Westar Energy	SPP	1, 3, 5, 6									
7. James Nail		City of Independence, MO	SPP	3									
11.	Group	Greg Campoli	IRC Standards Review Committee		X								
Additional Member		Additional Organization	Region	Segment Selection									
1. Charles Yeung		SPP	SPP	2									
2. Ben Li		IESO	NPCC	2									
3. Ali Miremadi		CAISO	WECC	2									
4. Lori Spence		MISO	MRO	2									
5. Cheryl Moseley		ERCOT	ERCOT	2									
6. Matt Goldberg		ISONE	NPCC	2									
7. Stephanie Monzon		PJM	RFC	2									
12.	Group	Jason Marshall	ACES Standards Collaborators						X				
Additional Member		Additional Organization	Region	Segment Selection									
1. Mark Ringhausen		Old Dominion Electric Cooperative	RFC	3, 4									
2. Scott Brame		North Carolina Electric Membership Corporation	SERC	3, 4, 5									
3. Ginger Mercier		Prairie Power	SERC	3									
4. Ellen Watkins		Sunflower Electric Power Corporation	SPP	1									
5. John Shaver		Arizona Electric Power Cooperative	WECC	4, 5									
6. John Shaver		Southwest Transmission Cooperative	WECC	1									
7. Bob Solomon		Hoosier Energy	RFC	1									
13.	Group	Pamela Hunter	Southern Company: Southern Company Services, Inc.; Alabama Power Company; Southern Company Generation, Southern Company Generation and Energy Marketing	X		X		X	X				
N/A													
14.	Group	Andrea Jessup	Bonneville Power Administration	X		X		X	X				
Additional Member		Additional Organization	Region	Segment Selection									
1. Steve Enyeart		Customer Service Engineering	WECC	1									
15.	Individual	Heather Bowden	EDP Renewables North America LLC					X					
16.	Individual	Jim Nail	Independence Power & Light			X		X					

Group/Individual		Commenter	Organization	Registered Ballot Body Segment										
				1	2	3	4	5	6	7	8	9	10	
17.	Individual	Joe Butterfield	Wisconsin Public Service Corporation			X								
18.	Individual	Terry Volkmann	Volkmann COnsulting, Inc								X			
19.	Individual	John Seelke	Public Service Enterprise Group	X		X		X	X					
20.	Individual	Anthony Jablonski	ReliabilityFirst											X
21.	Individual	Thomas Foltz	American Electric Power	X		X		X	X					
22.	Individual	Jo-Anne Ross	Manitoba Hydro	X		X			X					
23.	Individual	Si Truc PHAN	Hydro-Quebec TransEnergie	X										
24.	Individual	Timothy Brown	Idaho Power	X										
25.	Individual	Karin Schweitzer	Texas Reliability Entity											X
26.	Individual	David Jendras	Ameren	X		X		X	X					
27.	Individual	John Pearson	ISO New England		X									
28.	Individual	John Robertson	First Wind					X						
29.	Individual	George Brown	Acciona Energy North America Corporation					X						
30.	Individual	Israel Beasley	Georgia Transmission Corporation	X										
31.	Individual	Joshua Andersen	Salt River Project	X		X		X	X					
32.	Individual	Steven Lancaster	BES			X								
33.	Individual	Spencer	Tacke			X	X		X					
34.	Individual	Sergio Banuelos	Tri-State Generation and Transmission Association, Inc.	X		X		X						
35.	Individual	Michael Moltane	ITC	X										
36.	Individual	Joe Tarantino	Sacramento Municipal Utility District	X		X	X	X	X					

If you support the comments submitted by another entity and would like to indicate you agree with their comments, please select "agree" below and enter the entity's name in the comment section (please provide the name of the organization, trade association, group, or committee, rather than the name of the individual submitter).

Summary Consideration: The SDT thanks all commenters for their input and refers the reader to the summary response above.

Organization	Agree	Supporting Comments of "Entity Name"
Independence Power & Light	Agree	Southwest Power Pool
BES	Agree	FMPA

1. Do you agree with the revisions made in proposed PRC-005-2(X) to clarify applicability of PRC-005-2 to dispersed power producing resources included in the BES through Inclusion I4 of the BES definition? If not, please provide technical rationale for your disagreement along with suggested language changes.

Summary Consideration: The SDT thanks all commenters for their input and refers the reader to the summary response above.

Organization	Yes or No	Question 1 Comment
MRO NSRF	No	The proposed wording within the Applicability section of 4.2.5 is very wordy and without the Rational box for 4.2.5, entities will be very confused. The NSRF recommend that 4.2.5 be reworded to read; "Protection Systems for BES generation Facilities (Inclusion I4 assets are contained within section 4.2.6)". This will allow all BES connected generators to be covered by this Standard and clearly describes what is applicable per Inclusion I4 via 4.2.6.
Dominion	No	Dominion recommends revising 4.2.5 to read "Protection Systems for the following BES generator Facilities identified through Inclusions I2 and I3 of the BES definition:" as we believe it is more appropriate to cite how these BES generators are included under this section as opposed to indicating how they are not applicable under this section. Currently the standard's applicability is based first on the NERC Registration Criteria and secondly on facilities identified within the standard (4.2.5 Protection Systems for generator Facilities), regardless of their BES status. This proposed revisions means to change the applicability of the standard first to the NERC Registration Criteria and secondly on facilities identified within the standard (4.2.5 Protection Systems for BES generator Facilities). This BES generator Facilities change in 4.2.5 (i.e. Inclusions I2 and I3) essentially means the Protection System to be considered now is the "generator including the

Organization	Yes or No	Question 1 Comment
		generator terminals through the high-side of the step-up transformer” and no longer considers protection to the point of interconnection.
FirstEnergy	No	FirstEnergy abstains as we are not directly impacted by this project. Please see our response to Question #6.
SPP Standards Review Group	No	Rewrite the 1st line under Description of Current Draft to read: ‘This version of PRC-005 contains revisions to the applicability of the Standard intended to...’ This eliminates the redline typo. In order to minimize confusion regarding the use of the term ‘Facilities’ versus ‘facilities’ in the Applicability Section, we recommend changing the heading of 4.2 to ‘Applicable facilities’. Insert a space between the ‘apply’ and the ‘only’ in the 6th line of the Rationale Box for 4.2.6. Also expand the box down to capture all of the last line. We also suggest that the formatting in 4.2.6 parallel the formatting, or construction, of 4.2.5 in that specifics are listed in 4.2.5 and they are absent in 4.2.6. Or the drafting team could go in the other direction and modify 4.2.5 to match 4.2.6. The redline version contained several Rationale Boxes which are missing from the clean version. Were the boxes holdovers from previous versions making the clean version the correct copy or were they supposed to be included in the clean version?
EDP Renewables North America LLC	No	For consistency, it should be considered to have PRC-004 and PRC-005 to be applicable at an aggregate of greater than or equal to 75 MVA of BES facilities.
Wisconsin Public Service Corporation	No	The PRC-005-2(X) facilities sections (4.2.6 and 4.2.6.1) should be clarified and consistent with section 4.2.5. Suggested clarification: 4.2.6 Protection Systems for the following BES dispersed power producing resources identified through Inclusion I4 of the BES definition; excluding the individual resources: 4.2.6.1 Protection Systems that act to trip a common point of connection at 100 kV or above where those resources aggregate to greater

Organization	Yes or No	Question 1 Comment
		<p>than 75 MVA, either directly or via a lockout relay. OR4.2.6.1 Protection Systems that act to trip dispersed power producing resources common point of connection at 100 kV or above where those resources aggregate to greater than 75 MVA, either directly or via lockout relay.</p>
Public Service Enterprise Group	No	<p>In 4.2.6.1, “75MVA should be changed to “20MVA.” This would make it comparable to I2 generators. Although the change to 20MVA would have this standard apply to non-BES assets, many standards do likewise. In fact “Protection Systems,” which are the subject of this standard, are non-BES. As written, a reliability gap would be created between I4 generators and I2 generators. The proposed change violates Section 303 of the NERC Rules of Procedure, paragraph 1 that states: “Competition - A Reliability Standard shall not give any market participant an unfair competitive advantage.” If alternative language was proposed that required the same 75MVA threshold for I2 generators, PSEG would be fine with that. But the proposed non-comparable treatment of generators is not acceptable.</p>
Hydro-Quebec TransEnergie	No	<p>In Quebec, the RTP (Main Transmission System) Elements are applied instead of BES Elements. The Generation Facilities are greater than 50 MVA / 44kV instead of 75 MVA. Also in Quebec, NO Dispersed Generation is connected into the RTP network. To facilitate the compliance, the expression ‘inclusion I4’ should NOT include in the standard.</p>
Idaho Power	No	<p>Inclusion I4 of the BES definition specifically includes each generating resource. It is inconsistent to not include them for testing the protection systems under PRC-005. As written, there would be portions of the Bulk Electric System that would not be required to have the protection systems tested. A GO with a plant of small units aggregating above 75 MVA would be required to test the protection systems on all their units. How is this equitable? I understand that you have addressed this issue in the Consideration of Comments for the White Paper (Pg 9 & 10), however I</p>

Organization	Yes or No	Question 1 Comment
		disagree with your conclusion. If they individual resources are insignificant to test, they why are they considered part of the BES?
ISO New England	No	Under the standard, a conventional generating resource has to have a documented protection maintenance program which it must follow to ensure reliability. On the other hand, under the proposed revisions to the standard, a similarly-sized, dispersed power producing resource would not be required to do the same. If the standard is not applied to the dispersed generation resource, then there is no required protection maintenance, which can (and does in practice) result in more frequent trips, and degraded reliability. Loss of the dispersed generation resource (as distinct from individual units) would have the same impact as loss of a single, similarly sized conventional generating resource. Thus, a maintenance program that applies beyond the common point of connection should be required. The maintenance program should definitely be tailored to the type of dispersed generation power producing resource as determined by the GO/GOP, but having no requirement in place does not ensure reliable operations.
Tacke	No	For all three PRC-005 proposed modifications, I think we still need to replace the 75 MVA generator size requirement with the 20 MVA size requirement, for the following reasons:WECC requires dynamic model verification for all units 20 MVA or larger connected at voltages 60 kV and above. This is because WECC members have learned over the years to recognize the significant role that smaller size generators play in system response and stability. Also, the WECC MVWG (Modeling and Validation Work Group) is currently performing a study to determine what is the minimum size generator for which model testing and verification needs to be completed.Also, within the next few years, there will be thousands of MWs of PV solar plants on-line in Central California, a large percentage of which will be small, 20 MW plants. We see about 2,500 MW of 20 MW PV

Organization	Yes or No	Question 1 Comment
		units in the queue for the SGIP, SGIP-TC, WDAT, Clusters 1&2, and Clusters 3&4 in California, all coming on-line between now and 2018. Also, past WECC studies over the years of major outages have shown that generators, and indeed loads, below 100 kV, have played a major role in the impact of outages. In fact, the most accurate duplication of the August 1996 outage, and more recent outages that the WECC MVWG has simulated, have shown that the accuracy of the simulated results of actual system outages is highly affected by the accuracy of the modeled system below 100 kV.
Northeast Power Coordinating Council	Yes	
Arizona Public Service Company	Yes	
Duke energy	Yes	
DTE Electric	Yes	
SERC Protection and Controls Subcommittee	Yes	Please word the standard to clearly identify that PRC-005 becomes applicable on facilities where the aggregate generation sums to > 75MVA and it connects at >100kV. Please refer to Figures in the BES Definition Reference document to clearly identify the applicable facilities where the aggregate generation sums to > 75MVA and it connects at >100kV. For example in the BES Definition Reference Document Figures I4-1 through I4-4, is the protection system on the blue bus in the purple circle included given that the green feeders are not BES? Or, is just the transformer protection applicable since it is clearly all blue (BES) in the diagram? As another example in the BES Definition Reference Document Figure I4-1, can each of the 4 green strings of distributed generation be owned by the same or different companies, located at one or separate locations and the blue collector bus actually be a sub transmission line (or distribution line)?

Organization	Yes or No	Question 1 Comment
Florida Municipal Power Agency	Yes	
IRC Standards Review Committee	Yes	
ACES Standards Collaborators	Yes	We agree with the changes.
Southern Company: Southern Company Services, Inc.; Alabama Power Company; Southern Company Generation, Southern Company Generation and Energy Marketing	Yes	The drafting team has identified the appropriate aggregation point for dispersed power producing resources.
Bonneville Power Administration	Yes	This approach relies on maintenance practices of individual generators and collector systems before reaching the aggregation points as provided by the generator owner. This is in their best interest and in the best interest of the industry.
Volkman Consulting, Inc	Yes	
American Electric Power	Yes	
Manitoba Hydro	Yes	
Texas Reliability Entity	Yes	
Ameren	Yes	Ameren adopts the SERC PCS comments by reference
First Wind	Yes	Applicability is adequate for reliability.
Acciona Energy North America Corporation	Yes	

Organization	Yes or No	Question 1 Comment
Georgia Transmission Corporation	Yes	
Salt River Project	Yes	
Tri-State Generation and Transmission Association, Inc.	Yes	4.2.5 is written strangely. "Protection Systems for the following BES generator Facilities not identified through Inclusion I4 of the BES definition" reads better.
Sacramento Municipal Utility District	Yes	Please clarify whether Protection System Maintenance only applies to the aggregate transformers, but not the individual wind generators and its respective step-up transformers.

2. Do you agree with the revisions made in proposed PRC-005-3(X) to clarify applicability of PRC-005-3 to dispersed power producing resources included in the BES through Inclusion I4 of the BES definition? If not, please provide technical rationale for your disagreement along with suggested language changes.

Summary Consideration: The SDT thanks all commenters for their input and refers the reader to the summary response above.

Organization	Yes or No	Question 2 Comment
MRO NSRF	No	See comments per question 1.
Dominion	No	Dominion recommends revising 4.2.5 to read “Protection Systems for the following BES generator Facilities identified through Inclusions I2 and I3 of the BES definition:” as we believe it is more appropriate to cite how these BES generators are included under this section as opposed to indicating how they are not applicable under this section.
FirstEnergy	No	FirstEnergy abstains as we are not directly impacted by this project. Please see our response to Question #6.
SPP Standards Review Group	No	In order to minimize confusion regarding the use of the term ‘Facilities’ versus ‘facilities’ in the Applicability Section, we recommend changing the heading of 4.2 to ‘Applicable facilities’. We also suggest that the formatting in 4.2.6 parallel the formatting, or construction, of 4.2.5 in that specifics are listed in 4.2.5 and they are absent in 4.2.6. Or the drafting team could go in the other direction and modify 4.2.5 to match 4.2.6.
EDP Renewables North America LLC	No	For consistency, it should be considered to have PRC-004 and PRC-005 to be applicable at an aggregate of greater than or equal to 75 MVA of BES facilities.

Organization	Yes or No	Question 2 Comment
Wisconsin Public Service Corporation	No	The PRC-005-3(X) facilities sections (4.2.6 and 4.2.6.1) should be clarified and consistent with section 4.2.5. Suggested clarification: 4.2.6 Protection Systems for the following BES dispersed power producing resources identified through Inclusion I4 of the BES definition; excluding the individual resources: 4.2.6.1 Protection Systems that act to trip a common point of connection at 100 kV or above where those resources aggregate to greater than 75 MVA, either directly or via a lockout relay. OR4.2.6.1 Protection Systems that act to trip dispersed power producing resources common point of connection at 100 kV or above where those resources aggregate to greater than 75 MVA, either directly or via lockout relay.
Public Service Enterprise Group	No	The same comments in Q1 apply.
Hydro-Quebec TransEnergie	No	See response in question 1
Idaho Power	No	See discussion in #1.
ISO New England	No	See response for Question 1
Tacke	No	For all three PRC-005 proposed modifications, I think we still need to replace the 75 MVA generator size requirement with the 20 MVA size requirement, for the following reasons:WECC requires dynamic model verification for all units 20 MVA or larger connected at voltages 60 kV and above. This is because WECC members have learned over the years to recognize the significant role that smaller size generators play in system response and stability. Also, the WECC MVWG (Modeling and Validation Work Group) is currently performing a study to determine what is the minimum size generator for which model testing and verification needs to be completed.Also, within the next few years, there will be thousands of MWs of PV solar plants on-line in Central California, a large percentage of which will be small, 20 MW plants. We see about 2,500 MW of 20 MW PV units in the queue for the SGIP, SGIP-TC, WDAT, Clusters 1&2, and Clusters 3&4 in California, all coming on-line

Organization	Yes or No	Question 2 Comment
		between now and 2018. Also, past WECC studies over the years of major outages have shown that generators, and indeed loads, below 100 kV, have played a major role in the impact of outages. In fact, the most accurate duplication of the August 1996 outage, and more recent outages that the WECC MVWG has simulated, have shown that the accuracy of the simulated results of actual system outages is highly affected by the accuracy of the modeled system below 100 kV.
Northeast Power Coordinating Council	Yes	
Arizona Public Service Company	Yes	
Duke energy	Yes	
DTE Electric	Yes	
SERC Protection and Controls Subcommittee	Yes	See comments with Question 1.
Florida Municipal Power Agency	Yes	
IRC Standards Review Committee	Yes	
ACES Standards Collaborators	Yes	We agree with the changes.
Southern Company: Southern Company Services, Inc.; Alabama Power Company;	Yes	The drafting team has identified the appropriate aggregation point for dispersed power producing resources.

Organization	Yes or No	Question 2 Comment
Southern Company Generation, Southern Company Generation and Energy Marketing		
Bonneville Power Administration	Yes	This approach relies on maintenance practices of individual generators and collector systems before reaching the aggregation points as provided by the generator owner. This is in their best interest and in the best interest of the industry.
Volkman Consulting, Inc	Yes	
American Electric Power	Yes	
Manitoba Hydro	Yes	
Texas Reliability Entity	Yes	
Ameren	Yes	Ameren adopts the SERC PCS comments by reference
First Wind	Yes	Applicability is adequate for reliability.
Acciona Energy North America Corporation	Yes	
Georgia Transmission Corporation	Yes	The only comments I would suggest are fixing the wording in the Automatic Reclosing section 4.2.7.2 of PRC-005-3/PRC-005-X to refer to section 4.2.7.1 instead of 4.2.6.1. It appears this change was simply overlooked.
Salt River Project	Yes	

Organization	Yes or No	Question 2 Comment
Tri-State Generation and Transmission Association, Inc.	Yes	4.2.5 is written strangely. "Protection Systems for the following BES generator Facilities not identified through Inclusion I4 of the BES definition" reads better.
Sacramento Municipal Utility District	Yes	

3. Do you agree with the revisions made in proposed PRC-005-X(X) to clarify applicability of PRC-005-X (the version of PRC-005 containing revisions to address Sudden Pressure relays, being developed in Project 2007-17.1) to dispersed power-producing resources included in the BES through Inclusion I4 of the BES definition? If not, please provide technical rationale for your disagreement along with suggested language changes

Summary Consideration: The SDT thanks all commenters for their input and refers the reader to the summary response above.

Organization	Yes or No	Question 3 Comment
MRO NSRF	No	See comments per question 1.
Dominion	No	Dominion recommends revising 4.2.5 to read “Protection Systems for the following BES generator Facilities identified through Inclusions I2 and I3 of the BES definition:” as we believe it is more appropriate to cite how these BES generators are included under this section as opposed to indicating how they are not applicable under this section.
FirstEnergy	No	FirstEnergy abstains as we are not directly impacted by this project. Please see our response to Question #6.
SPP Standards Review Group	No	Shouldn't the reference to PRC-005-3 in the 2nd line under the Description of Current Draft be to PRC-005-4?The redline version shows a Rationale Box with the Introduction Section. This box, even though it contains redline changes, is not included in the clean version. Were the redline changes holdovers from a previous version and should not have been shown in this redline or were they supposed to be included in the clean version?In order to minimize confusion regarding the use of the term 'Facilities' versus 'facilities' in the Applicability Section, we recommend changing the heading of 4.2 to 'Applicable facilities'.The page header includes the PRC-005-4(X) label while within the standard itself it is shown as PRC-005-X. Which is correct?We would also suggest that the formatting in 4.2.6 parallel the formatting, or construction, of 4.2.5 in that specifics are listed in 4.2.5 and they are absent in 4.2.6. Or the drafting team could go in the other direction and modify

Organization	Yes or No	Question 3 Comment
		4.2.5 to match 4.2.6.The Rationale Boxes for 4.2.5 and 4.2.6 cover-up text. The boxes need to be moved such that they do not cover-up any text.
EDP Renewables North America LLC	No	For consistency, it should be considered to have PRC-004 and PRC-005 to be applicable at an aggregate of greater than or equal to 75 MVA of BES facilities.
Wisconsin Public Service Corporation	No	The PRC-005-X(X) facilities sections (4.2.6 and 4.2.6.1) should be clarified and consistent with section 4.2.5. Suggested clarification: 4.2.6 Protection Systems for the following BES dispersed power producing resources identified through Inclusion I4 of the BES definition; excluding the individual resources: 4.2.6.1 Protection Systems that act to trip a common point of connection at 100 kV or above where those resources aggregate to greater than 75 MVA, either directly or via a lockout relay. OR4.2.6.1 Protection Systems that act to trip dispersed power producing resources common point of connection at 100 kV or above where those resources aggregate to greater than 75 MVA, either directly or via lockout relay. In addition, there should be further clarification surrounding the inclusion/exclusion of the sudden pressure relay.
Public Service Enterprise Group	No	The same comments in Q1 apply.
Idaho Power	No	See discussion in #1.
ISO New England	No	See response for Question 1
Salt River Project	No	Sudden pressure relays are not “necessary”, in fact, older transformers will likely not have them. What is necessary for “reliable operation” as defined in the statute are the differential relays, overcurrent relays, etc., that are there to clear a major phase to phase or phase to ground fault that if left uncleared can cause instability. A sudden pressure relay is there primarily for equipment health monitoring, e.g., detecting a turn-to-turn failure, not a phase to ground or phase to phase fault. If a sudden pressure relay fails to operate, there is no threat to BPS reliability since the differential relay / overcurrent relays are there if the fault develops into a major phase to ground or phase to phase fault.
Tacke	No	For all three PRC-005 proposed modifications, I think we still need to replace the 75 MVA generator size requirement with the 20 MVA size requirement, for the following reasons:WECC requires dynamic model verification for all units 20 MVA or larger connected at voltages 60 kV and above. This is because WECC members have learned over the years to recognize the significant role that smaller size generators play in system response and stability. Also, the WECC MVWG (Modeling and Validation Work Group) is currently performing a study to determine what is the minimum size generator for which model testing and verification needs to be completed.Also, within the next few years, there will be thousands of MWs of PV solar plants on-line in Central California, a large

Organization	Yes or No	Question 3 Comment
		percentage of which will be small, 20 MW plants. We see about 2,500 MW of 20 MW PV units in the queue for the SGIP, SGIP-TC, WDAT, Clusters 1&2, and Clusters 3&4 in California, all coming on-line between now and 2018. Also, past WECC studies over the years of major outages have shown that generators, and indeed loads, below 100 kV, have played a major role in the impact of outages. In fact, the most accurate duplication of the August 1996 outage, and more recent outages that the WECC MVWG has simulated, have shown that the accuracy of the simulated results of actual system outages is highly affected by the accuracy of the modeled system below 100 kV.
Northeast Power Coordinating Council	Yes	
Arizona Public Service Company	Yes	
Duke energy	Yes	
DTE Electric	Yes	
SERC Protection and Controls Subcommittee	Yes	See comments with Question 1.
Florida Municipal Power Agency	Yes	
IRC Standards Review Committee	Yes	
ACES Standards Collaborators	Yes	We agree with the changes.
Bonneville Power Administration	Yes	This approach relies on maintenance practices of individual generators and collector systems before reaching the aggregation points as provided by the generator owner. This is in their best interest and in the best interest of the industry.
Volkman Consulting, Inc	Yes	
American Electric Power	Yes	Was the omission of sudden pressure relays for dispersed generation resources under PRC-005-X Applicability 4.2.6 intentional? In light of the FERC directive associated with SPRs, we are unsure if FERC will accept a version of the standard that does not require testing of SPRs for transformers connected between the point that the resources aggregate to greater than 75 MVA and the point of interconnection.
Manitoba Hydro	Yes	
Texas Reliability Entity	Yes	

Organization	Yes or No	Question 3 Comment
Ameren	Yes	Ameren adopts the SERC PCS comments by reference
First Wind	Yes	Applicability is adequate for reliability.
Acciona Energy North America Corporation	Yes	
Georgia Transmission Corporation	Yes	The only comments I would suggest are fixing the wording in the Automatic Reclosing section 4.2.7.2 of PRC-005-3/PRC-005-X to refer to section 4.2.7.1 instead of 4.2.6.1. It appears this change was simply overlooked.
Tri-State Generation and Transmission Association, Inc.	Yes	4.2.5 is written strangely. "Protection Systems for the following BES generator Facilities not identified through Inclusion I4 of the BES definition" reads better.
Sacramento Municipal Utility District	Yes	

4. Do you agree with the revisions made in proposed VAR-002-2b(X) to clarify applicability of VAR-002-2b to dispersed power producing resources included in the BES through Inclusion I4 of the BES definition? If not, please provide technical rationale for your disagreement along with suggested language

Summary Consideration: The SDT thanks all commenters for their input and refers the reader to the summary response above.

Organization	Yes or No	Question 4 Comment
MRO NSRF	No	The NSRF agrees with the proposed Requirements but has issues with the associated Ration for Footnote 5 in R4, Part 4.1, note that Transmission Provider should be Transmission Planner. The auxiliary transformers stated in R4.1 are usually transformers that provide station services to the generator. The first sentence of the Ration is correct. The second sentence is out of line since it is directed to the collector system (34.5kV), this should be deleted. This rewrite will provide simple clarity that the foot note is trying to provide.
FirstEnergy	No	FirstEnergy abstains as we are not directly impacted by this project. Please see our response to Question #6.
SPP Standards Review Group	No	References to R4 and R5 in the Description of Current Draft Section should be to R3 and R4. Also delete the BES in front of Bulk Electric Systems in the line in which the references are made.The proposed change to Requirement R3, Part 3.1 is okay as long as the number of individual units in an aggregated site is not detrimental to the overall operation of the entire site. In that case, the site status, for the entire aggregated facility, should be reported. If this is the intent of Part 3.2, it needs additional clarification to make it stand out.The Rationale Box for Footnote 5

Organization	Yes or No	Question 4 Comment
		references the Transmission Provider and in one instance only references Transmission. We believe these references should be to the Transmission Planner as indicated in Requirement R4.
Volkman COnsulting, Inc	No	The change is neither consistent with the delineation in PRC-004 / 5 nor inclusive of the dispersed generation issue. My interpretation is that VAR-002 change only address change in reactive capability and does not address automatic voltage control and status at each generator site. VAR-002 should be written explicitly to only applicable at the point of aggregation to 75 MVA with the transmission system.
Public Service Enterprise Group	No	How does one interpret the added “bullet” in R3? The new bullet statement belongs in the Applicability section. Furthermore, the statement creates a reliability gap between I4 generators and I2 generators. It also violates Section 303 of the NERC Rules of Procedure, paragraph 1 that states: “Competition - A Reliability Standard shall not give any market participant an unfair competitive advantage.” We suggest the following addition to the bullet to correct both issues (added language is CAPITALIZED): “... Bulk Electric Definition; HOWEVER, REPORTING CHANGES ARE REQUIRED AT THE POINT THAT INDIVIDUAL INCLUSION I4 BES GENERATORS AGGREGATE TO GREATER THAN 20MVA.”
Hydro-Quebec TransEnergie	No	See response in question 1
Tacke	No	For both VAR-002 proposed modifications, I don’t think we should state non-applicability of the Standard for dispersed generation resources identified through Inclusion I4 of the BES definition, for the following reasons: WECC requires dynamic model verification for all units 20 MVA or larger connected at voltages 60 kV and above. This is because WECC members have learned over the years to recognize the significant role that smaller size generators play in system response and stability. Also, the WECC MVWG (Modeling and Validation Work Group) is currently performing a study to determine what is the minimum size generator for which model testing and verification needs to be completed. Also, within the next few years,

Organization	Yes or No	Question 4 Comment
		<p>there will be thousands of MWs of PV solar plants on-line in Central California, a large percentage of which will be small, 20 MW plants. We see about 2,500 MW of 20 MW PV units in the queue for the SGIP, SGIP-TC, WDAT, Clusters 1&2, and Clusters 3&4 in California, all coming on-line between now and 2018. Also, past WECC studies over the years of major outages have shown that generators, and indeed loads, below 100 kV, have played a major role in the impact of outages. In fact, the most accurate duplication of the August 1996 outage, and more recent outages that the WECC MVWG has simulated, have shown that the accuracy of the simulated results of actual system outages is highly affected by the accuracy of the modeled system below 100 kV.</p>
Northeast Power Coordinating Council	Yes	
Arizona Public Service Company	Yes	
Dominion	Yes	<p>Rationale for R4, need to change Transmission Provider to ‘Transmission Planner’. Since this standard is being revised, Dominion suggests that NERC request the SDT to re-align the Measures with the Requirements to develop a more risk-based standard as NERC has proposed going forward.</p>
Duke energy	Yes	<p>Duke Energy suggests the following revision: “Reporting of status or capability changes is not applicable to the individual dispersed power producing resources identified through Inclusion I4 (a) of the Bulk Electric System definition.” We believe the addition of “I4 (a)” helps clarify the applicability for individual dispersed power producing resources.</p>
DTE Electric	Yes	

Organization	Yes or No	Question 4 Comment
ACES Standards Collaborators	Yes	<p>(1) We agree with the proposed changes. However, we believe additional changes are needed to the standard.(2) Requirement R1 needs to be modified as well. Because each individual generating unit of a dispersed generation site that exceeds the 75 MVA threshold is included as part of the BES, R1 would apply and would require each of these units to be operated with AVR in voltage regulating mode. These units usually do not have an AVR and are not capable of controlling voltage. Rather, they rely on other voltage regulating equipment such as SVC or capacitor banks to control voltage at the interconnecting point. Thus, we request that R1 is modified so that is not applicable to the individual units of the dispersed power producing resources. (3) Similar to R1, R2 should also be modified to reflect that these dispersed generation resources often do not have AVRs and must rely on other voltage regulating equipment to control voltage at the interconnecting point. Thus, we request that R2 is modified so that is not applicable to the individual units of the dispersed power producing resources.</p>
Southern Company: Southern Company Services, Inc.; Alabama Power Company; Southern Company Generation, Southern Company Generation and Energy Marketing	Yes	
Bonneville Power Administration	Yes	
EDP Renewables North America LLC	Yes	

Organization	Yes or No	Question 4 Comment
Wisconsin Public Service Corporation	Yes	
ReliabilityFirst	Yes	ReliabilityFirst submits the following comments for consideration:1. VAR-002-2b(X) Requirement 3, Part 3.1 - The exclusion for dispersed power producing resources is shown as a bullet point and bullet points are historically described as “OR” statements in NERC Reliability Standards. ReliabilityFirst recommends adding the bulleted language to the end of Requirement 3, Part 3.1 as follows: “A status or capability change on any generator Reactive Power resource, including the status of each automatic voltage regulator and power system stabilizer and the expected duration of the change in status or capability. Reporting of status or capability changes is not applicable to the individual dispersed power producing resources identified through Inclusion I4 of the Bulk Electric System definition.”
American Electric Power	Yes	
Manitoba Hydro	Yes	
Idaho Power	Yes	
Texas Reliability Entity	Yes	
Ameren	Yes	
First Wind	Yes	
Acciona Energy North America Corporation	Yes	
Salt River Project	Yes	

Organization	Yes or No	Question 4 Comment
Tri-State Generation and Transmission Association, Inc.	Yes	
Sacramento Municipal Utility District	Yes	: Please clarify that Protection System Misoperations of the individual wind generators affects only themselves, but will not cause an aggregate effect with other wind turbines. For example, this standard only applies to aggregate substation transformers. There is a concern that still lies on meeting requirements R1 and R2, operating in voltage control mode. Some existing wind generators operate in a power factor control mode, not voltage control mode, and is not capable of operating in either voltage or power factor control mode.
SERC Protection and Controls Subcommittee		no comment
Florida Municipal Power Agency		In the rationale for Footnote 5 in Requirement R4, Part 4.1 the references to Transmission Provider should be Transmission Planner. The reference to “Transmission” should be Transmission Planner.
IRC Standards Review Committee		The proposed change to Requirement R3, Part 3.1 is okay as long as the net change to number of the individual units in an aggregated site is not detrimental to affect the overall operation of the entire site or the proper management and control of reactive resources of the site. In that case, the site status, for the entire aggregated facility, should be reported. If this is the intent of Part 3.2 is intended to cover the latter situation (where the impact of changes to individual disperse generating sources is reported at the aggregate level), then Part 3.2 needs , it needs additional to be expanded to clarify it. clarification to make it stand out. Otherwise, the impact of changes to individual units will not be identified and reported for control to meet the objective of control and management of reactive resources.The Rationale Box for Footnote 5 references the Transmission Provider and in one instance only references

Organization	Yes or No	Question 4 Comment
		Transmission. We believe these references should be to the Transmission Planner as indicated in Requirement R4.

5. Do you agree with the revisions made in proposed VAR-002-4 to clarify applicability of VAR-002-3 to dispersed power producing resources included in the BES through Inclusion I4 of the BES definition? If not, please provide technical rationale for your disagreement along with suggested language changes

Summary Consideration: The SDT thanks all commenters for their input and refers the reader to the summary response above.

Organization	Yes or No	Question 5 Comment
MRO NSRF	No	The bulleted item under R4 is too wordy and recommend the following rewrite to provide clarity; “Reporting of reactive capability changes is not applicable to (delete “the”) individual (delete “for “) dispersed power producing resources identified through Inclusion I4 of the Bulk Electric System definition.
FirstEnergy	No	FirstEnergy abstains as we are not directly impacted by this project. Please see our response to Question #6.
SPP Standards Review Group	No	Since VAR-002-4 only contains minor technical revisions dealing with the applicability specifically for Requirements R4 and R5, is it feasible to believe that VAR-002-4 will be approved before VAR-002-3? The special provisions for ‘the later of’ aren’t

Organization	Yes or No	Question 5 Comment
		<p>needed. Simply go with the normal Effective Date language. Additionally, the way this section is currently worded in those jurisdictions requiring governmental approval, the standard becomes effective immediately upon governmental approval. Yet, if governmental approval is not required, the standard would become effective the first day of the first calendar quarter following NERC Board approval. The concept of ‘the first day of the first calendar quarter following approval’ needs to be added to the governmental approval clause. The same argument applies to the proposed change for Requirement R4 as we put forth in response to the proposed change to Requirement R3, Part 3.1 in VAR-002-2b(X) in Question 4. The proposal is okay provided that only lost capability of a few individual units does not detract from the overall capability of the entire aggregated site. If the capability of the entire site is degraded the notification should be made. Also, insert the term ‘generator’ between ‘individual’ and ‘for’ in the bullet under Requirement R4. Requirement R5 is a duplicate of Requirement R4 and needs to be replaced with the correct wording from VAR-002-2b(X), Requirement R4. The clean version is missing the Rationale Box for Footnote 5.</p>
Volkman Consulting, Inc	No	see question 4
Public Service Enterprise Group	No	The same comments in Q3 apply, except replace “R3” with “R4.”
Hydro-Quebec TransEnergie	No	See response in question 1
Ameren	No	<p>(1) Regarding proposed standard VAR-002-4, we believe that some language is missing for requirement R5.1. Shouldn't the requirement state that the Generator Operator needs to provide the information on Tap Settings, Available fixed tap ranges, and Impedance data to the Transmission Operator?(2) We believe that VAR-002-4 should include a 30 day time period to complete R5, as alluded to in M5.</p>

Organization	Yes or No	Question 5 Comment
Acciona Energy North America Corporation	No	I agree with the intent of the SDT, however, the balloted version VAR-002-4 is incorrect.VAR-002-4 R4: added applicability clause is incorrect and miswordedVAR-002-4 R5: Requirement is incorrect and not original requirement from version 3 of this standard
Tacke	No	For both VAR-002 proposed modifications, I don't think we should state non-applicability of the Standard for dispersed generation resources indentified through Inclusion I4 of the BES definition, for the following reasons: WECC requires dynamic model verification for all units 20 MVA or larger connected at voltages 60 kV and above. This is because WECC members have learned over the years to recognize the significant role that smaller size generators play in system response and stability. Also, the WECC MVWG (Modeling and Validation Work Group) is currently performing a study to determine what is the minimum size generator for which model testing and verification needs to be completed.Also, within the next few years, there will be thousands of MWs of PV solar plants on-line in Central California, a large percentage of which will be small, 20 MW plants. We see about 2,500 MW of 20 MW PV units in the queue for the SGIP, SGIP-TC, WDAT, Clusters 1&2, and Clusters 3&4 in California, all coming on-line between now and 2018.Also, past WECC studies over the years of major outages have shown that generators, and indeed loads, below 100 kV, have played a major role in the impact of outages. In fact, the most accurate duplication of the August 1996 outage, and more recent outages that the WECC MVWG has simulated, have shown that the accuracy of the simulated results of actual system outages is highly affected by the accuracy of the modeled system below 100 kV.
Northeast Power Coordinating Council	Yes	
Arizona Public Service Company	Yes	

Organization	Yes or No	Question 5 Comment
Dominion	Yes	Rationale for R5, need to change Transmission Provider to 'Transmission Planner'.
Duke energy	Yes	Duke Energy suggests the following revision: "Reporting of reactive capability changes is not applicable to the individual dispersed power producing resources identified through Inclusion I4 (a) of the Bulk Electric System definition." We believe the addition of "I4 (a)" helps clarify the applicability for individual dispersed power producing resources. We would also like to point out an apparent typo in R4 and suggest modifying "individual for dispersed power producing resources" to "individual dispersed power producing resources". The removal of "for" provides consistency with the language in VAR-002-2b.
DTE Electric	Yes	
IRC Standards Review Committee	Yes	
ACES Standards Collaborators	Yes	(1) We agree with the proposed changes. However, we believe additional changes are needed to the standard.(2) Requirement R1 needs to be modified as well. Because each individual generating unit of a dispersed generation site that exceeds the 75 MVA threshold is included as part of the BES, R1 would apply and would require each of these units to be operated with AVR in voltage regulating mode. These units usually do not have an AVR and are not capable of controlling voltage. Rather, they rely on other voltage regulating equipment such as SVC or capacitor banks to control voltage at the interconnecting point. Thus, we request that R1 is modified so that is not applicable to the individual units of the dispersed power producing resources. (3) Similar to R1, R2 should also be modified to reflect that these dispersed generation resources often do not have AVRs and must rely on other voltage regulating equipment to control voltage at the interconnecting point. Thus, we request that R2 is modified so that is not applicable to the individual units of the dispersed power producing resources.

Organization	Yes or No	Question 5 Comment
Southern Company: Southern Company Services, Inc.; Alabama Power Company; Southern Company Generation, Southern Company Generation and Energy Marketing	Yes	
Bonneville Power Administration	Yes	
EDP Renewables North America LLC	Yes	
Wisconsin Public Service Corporation	Yes	
American Electric Power	Yes	
Manitoba Hydro	Yes	
Idaho Power	Yes	
Texas Reliability Entity	Yes	1)Texas RE agrees with the change to applicability but points out that there may be an error in the language of R5 of VAR-002-4. Requirement 4 and 5 have the exact same requirement language:“Each Generator Operator shall notify its associated Transmission Operator within 30 minutes of becoming aware of a change in reactive capability due to factors other than a status change described in Requirement R3. If the capability has been restored within 30 minutes of the Generator Operator becoming aware of such change, then the Generator Operator is not required to notify the Transmission Operator of the change in reactive capability.”Requirement 5

Organization	Yes or No	Question 5 Comment
		<p>goes on to add: “For generator step-up transformers and auxiliary transformers5 with primary voltages equal to or greater than the generator terminal voltage:5.1.1. Tap settings.5.1.2. Available fixed tap ranges.5.1.3. Impedance data. The requirements in VAR-002-2b (R4) and VAR-002-3 (R5) that include the tap settings, ranges and impedance data language have the following requirement language:”The Generator Owner shall provide the following to its associated Transmission Operator and Transmission Planner within 30 calendar days of a request.” Texas RE requests the SDT review the language to assure the correct requirement language is included in Requirement R5 of VAR-002-4.2)It appears that R7 of VAR-002-4 should actually be the Measure for R6, not a Requirement. 3)It appears that VAR-002-2b(X) Requirement R3.1 and VAR-002-4 Requirement R4 map to each other but the exclusion language is slightly different. VAR-002-4, R4 has the word “for” between “individual” and “dispersed power” whereas VAR-002-2b(X) does not. The addition of the word makes the requirement confusing. It may just be a typo but Texas RE wanted to bring this to the attention of the SDT. VAR-002 -2b(X) Requirement R3.1 language: Reporting of status or capability changes is not applicable to the individual dispersed power producing resources identified through Inclusion I4 of the Bulk Electric System definition. VAR-002-4 Requirement R4 language: Reporting of reactive capability changes is not applicable to the individual for dispersed power producing resources identified through Inclusion I4 of the Bulk Electric System definition.</p>
First Wind	Yes	
Salt River Project	Yes	
Tri-State Generation and Transmission Association, Inc.	Yes	<p>"R7" should be "M6". The effective date is confusing as written and makes it seem as if the standard would be effective immediately. Was that the SDT's intentions? Since VAR-002-3 is still waiting on FERC approval and is not effective yet the industry should have some time to prepare for VAR-002-4.</p>

Organization	Yes or No	Question 5 Comment
SERC Protection and Controls Subcommittee		no comment
Florida Municipal Power Agency		In the added bullet to R4, the word “for” should be deleted. In the rationale for Footnote 5 in Requirement R5, Part 5.1 the references to Transmission Provider should be deleted. The reference to “Transmission” should be deleted. Although not in the scope of this particular SDT, the reference to Transmission Planner in M5 should be deleted since notification is not required by R5.

6. Do you have any additional comments to assist the DGR SDT in further developing its recommendations?

Summary Consideration: The SDT thanks all commenters for their input and refers the reader to the summary response above.

Organization	Yes or No	Question 6 Comment
Northeast Power Coordinating Council	No	
Arizona Public Service Company	No	
DTE Electric	No	
SERC Protection and Controls Subcommittee	No	The comments expressed herein represent a consensus of the views of the above-named members of the SERC EC Protection and Control Subcommittee only and

Organization	Yes or No	Question 6 Comment
		should not be construed as the position of SERC Reliability Corporation, its board, or its officers.
Florida Municipal Power Agency	No	
ACES Standards Collaborators	No	
Southern Company: Southern Company Services, Inc.; Alabama Power Company; Southern Company Generation, Southern Company Generation and Energy Marketing	No	
Bonneville Power Administration	No	
Wisconsin Public Service Corporation	No	
Volkman Consulting, Inc	No	
Public Service Enterprise Group	No	
American Electric Power	No	
Manitoba Hydro	No	

Organization	Yes or No	Question 6 Comment
Hydro-Quebec TransEnergie	No	
Texas Reliability Entity	No	
Ameren	No	
First Wind	No	
Acciona Energy North America Corporation	No	
Salt River Project	No	
Tacke	No	
Tri-State Generation and Transmission Association, Inc.	No	
MRO NSRF	Yes	Please note that NERC has already written a proposed Guidance document on these Standards, including PRC-004. The NSRF, request that the SDT coordinate with NERC so that any Standard and Guidance document complement each other.
Dominion	Yes	Dominion, from a philosophical perspective, cannot support a continent-wide standard (VAR-002) that does not grant a waiver (or waivers) where one or more approved regional standard exists. We cite the following as reason supporting this philosophy; PRC-006, Docket # RM11-20 - In Order No. 763 (issued on May 7, 2012), the Commission directed NERC to submit a Compliance Filing regarding several aspects including how it will address the Commission’s directive to establish a schedule by the planning coordinator to comply with PRC-006-1 Requirement R9. In its compliance filing, NERC stated that an entity must be compliant with both the continent wide PRC-006 Standard and the regional standard proposed by SERC in

Organization	Yes or No	Question 6 Comment
		<p>Docket No. RM12-9. Dominion intervened requesting that the Commission modify Requirement R6 to require each UFLS entity in the SERC Region to implement changes to the UFLS scheme within the lesser of 18 months of notification by the planning coordinator, or the schedule established by the planning coordinator. In reply to SERC’s responsive comments, Dominion disagrees that its concerns have been adequately addressed. Dominion states that “it is unjust to hold a registered entity responsible for compliance to any requirement within a reliability standard where such compliance is dependent upon that registered entity having also read, and taken into consideration, all statements issued by FERC, NERC and the Regional Entity. The Commission declined Dominion’s request and instead affirmed the interpretation as set forth in NERC and SERC’s comments. PRC-002-2 - NPCC received approval of its regional standard (PRC-002-NPCC-01) in October 2011. That standard also contained an implementation plan which provides staggered effective dates, i.e., the date on which applicable entities are subject to mandatory compliance, with full compliance required within four years of regulatory approval. During the comment period, Dominion stated potential for conflict between the approved regional standard and the draft continent-wide standard, and also noted that registered entities in that region are 2 years into the 4 year implementation which creates uncertainty for NPCC applicable entities. The drafting team’s response did not adequately address Dominion’s concerns. Dominion does not agree with the response provided by the SDT relative to comments related to PRC-006, specifically the regional (NPCC and SERC) versions. Both of these approved regional standards apply to Generator Owner and we therefore agree that the SDT should include the continent wide standard in its review.</p>
Duke energy	Yes	<p>PRC-005 Implementation Plans: We suggest removing “first day following” in all the PRC-005 implementation plans. It appears that as written, there could be a gap between the effective date and retirement date of these standards. VAR-002-2b RSAW : We suggest adding I4 (a) to the R3 Note To Auditor Section of the RSAW for consistency with our comments to Question 4 as follows: “Requirement R3.1 is not applicable to individual dispersed power producing resources identified through</p>

Organization	Yes or No	Question 6 Comment
		<p>Inclusion I4 (a) of the Bulk Electric System definition. Entity assertions regarding applicability of Requirement R3.1 should be supported by evidence such as one-line diagrams, nameplate ratings, manufacturer information, or BES inclusion documentation available at the Regional Entity.”VAR-002-3 RSAW : We suggest adding I4 (a) to the R4 Note To Auditor Section of the RSAW with our comments to Question 5 as follows:”Requirement R4 is not applicable to the individual dispersed power producing resources identified through Inclusion I4 (a) of the Bulk Electric System definition. Entity assertions regarding applicability of Requirement R4 should be supported by evidence such as one-line diagrams, nameplate ratings, manufacturer information, commissioning tests, etc.”</p>
FirstEnergy	Yes	<p>FirstEnergy abstains as we are not directly impacted by this project. We question the efficiency of modifying several NERC Reliability Standards in lieu of potentially adjusting the NERC BES definition which may more effectively address the concerns. Additionally there are other revisions to the NERC BES definition needed in regard to generation assets. As written, there is inequality in the NERC BES definition for traditional generation resources versus dispersed generation. A single traditional unit of 25 MVA must meet all NERC Reliability Standards that apply to Generator Owners yet for the dispersed generation they are only subject to the extent that they total 75 MVA or more. When there are standards before FERC pending regulatory approval, all subsequent revisions should be based on the latest NERC Board approved version. It is our opinion that the approach taken to modify and post for ballot several versions of the same standard is inefficient, overly complicated and unnecessarily causes industry confusion. We suggest that the NERC Standards Committee reassess the need to make this a standalone project and work the intended revisions into current ongoing projects.</p>
SPP Standards Review Group	Yes	<p>The various Implementation Plans for each version of PRC-005 are cross referenced in the Implementation Plans for PRC-005-2(X), PRC-005-3(X) and PRC-005-X(X) in this project. We suggest a change in language to an item in the Background Section of each of those referenced Implementation Plans. We propose the following: ‘2. For</p>

Organization	Yes or No	Question 6 Comment
		<p>entities not presently performing a maintenance activity or using longer intervals than the maximum allowable intervals established in the proposed standard, it is unrealistic for those entities to be immediately compliant with the new activities or intervals. Further, entities should be allowed to become compliant in such a way as to facilitate a continuing maintenance program. Those entities which now fall under the requirements of the standard due to BES definition changes would have twenty-four months from the applicable effective date to demonstrate compliance.’ This would eliminate the potential for a repeat of the fiasco of a few years back associated with implementation of PRC-005-1 in which evidence of compliance was required prior to the effective date of the standard. There is inconsistency among the proposed standards on the term dispersed power producing facilities. In some instances power producing is hyphenated, in others it is not. In some instances facilities is capitalized, in others it is not. The SDT needs to determine which is correct and stick to it. There is inconsistency among the proposed standards on the use of the terms 75 MVA and 100 kV. In some instances they are shown with the space and in others they are shown without the space as 75MVA and 100kV. The SDT, again, needs to determine which is correct and stick to it.</p>
ISO New England	Yes	<p>In PRC-005-2(X), under A.2, the number “2” should not have been deleted and the letter “X” should be in parenthesis as it is shown in the header. In PRC-005-2(X), and VAR-002-2b(X), under D. Compliance 1.1 - It is not necessary to repeat the definition of Compliance Enforcement Authority. A reference to the NERC Rules of Procedure is sufficient. The benefit is that, if the definition ever changes there, it will not have to be changed here. Therefore, 1.1 under Compliance should simply say: “Compliance Enforcement Authority” has the meaning ascribed to it in the NERC Rules of Procedure.</p>
Georgia Transmission Corporation	Yes	<p>The only comments I would suggest are fixing the wording in the Automatic Reclosing section 4.2.7.2 of PRC-005-3/PRC-005-X to refer to section 4.2.7.1 instead of 4.2.6.1. It appears this change was simply overlooked.</p>

Organization	Yes or No	Question 6 Comment
ITC	Yes	<p>Regarding VAR-002, ITC makes the following comments: The Standard should define dispersed power producing resource. While in a practical sense this is a facility comprised of wind turbines or PV inverters, offering exclusions from Requirements based on an undefined criteria is not a good practice. R4 - ITC recommends removal of the sub-bullet under R4 excluding the generators identified through Inclusion I4. The exclusion using BES I4 is confusing and may conflict with existing standard VAR-001-4. A non-BES unit or several non-BES units combined together could have an impact on the BES and thus removing the generators from VAR-002-4 R4 solely based on Inclusion I4 may be detrimental to reliability. Per VAR-001-4 R4, the TOP is required to specify criteria that will exempt generators from following a voltage or reactive power schedule and associated notification requirements. Therefore, ITC recommends that VAR-002-3 R4 should be reworded as “Unless exempted by the Transmission Operator, each Generator Operator shall notify its associated Transmission Operator within 30 minutes of becoming aware of a change in reactive capability due to factors other than a status change described in Requirement 3”. The TOP can determine what notifications are necessary and be more specific depending on the needs of the system or individual facility. For example, a TOP exemption criteria may contain: “Dispersed power producing facilities are exempt from reactive capability change notifications less than 10% of the total aggregate lagging reactive capability as measured at the POI at nominal voltage”. TOPs typically will not want to receive individual turbine outage notifications; however, there may be instances where a dispersed power producing resource could lose an individual unit that may affect reliable operations (i.e. large individual units). In addition, the sub-bullet language in VAR-002-4 may be interpreted such that generators not in BES are exempt from reactive capability notifications and, in turn, exempt from following schedules which may be in conflict with VAR-001-4 and potentially impact the reliability of the BES. VAR-001-4 requires the TOP to determine the exemption criteria for generators and ITC recommends that VAR-002-4 be consistent with this practice as the TOP may require non-BES generators to follow a voltage or reactive power schedule based on the collective impact to the BES. R5 - The language in VAR-</p>

Organization	Yes or No	Question 6 Comment
		002-4 R5 is a repeat of the VAR-002-4 R4 language and does not correspond to sub-requirement R5.1 . Replace with appropriate R5 language from VAR-002-3. Similar to R4, the exclusion shouldn't be based on BES I4. ITC recommends the footnote is reworded to: "For dispersed power producing resources, this requirement applies only to those transformers that have at least one winding at the same or higher voltage as the lowest voltage Point of Interconnection location(s)."
Sacramento Municipal Utility District	Yes	<p>Comment 1: These revisions are logical and simply needed to clarify applicability. In fact, not approving these revisions may be detrimental to reliability or not useful to the support of the reliable operation of the BES. Moreover, preparing for implementation under the chance the revisions are not approved is diverting time and resources that could otherwise be devoted to efforts that do contribute to the reliable operation of the BES.</p> <p>Comment 2: Please proceed expeditiously with these revisions and convey such urgency to the approving entities. Although the goal of this effort is to ensure these revisions are approved prior to the June 2016 effective date for newly identified elements under the BES definition, affected entities have no alternative but to expend resources and devote time to plan, prepare and begin compliance related activities well before June 2016.</p>
IRC Standards Review Committee		There are multiple postings of the PRC-005 currently underway, each effort addressing different changes. Although we support and understand the need to adhere to the standards development process for standards projects, each one will have individual postings and ballots. This makes it cumbersome to reference and review layers of changes that may impact the other postings and can lead to confusion and unanticipated voting outcomes. The drafting teams need to explain how each proposed change to PRC-005 is not relevant or impactful on the other.
EDP Renewables North America LLC		Thank you for your time and efforts.

END OF REPORT

Standard Development Timeline

This section is maintained by the drafting team during the development of the standard and will be removed when the standard becomes effective.

Development Steps Completed

1. SAR posted for comment November 20, 2013 – December 19, 2013.
2. An earlier draft of this standard was posted for a 45-day comment and ballot period June 12, 2014–July 29, 2014.
3. PRC-005-3(X) passed a final ballot, which was posted for a 10-day ballot period of August 27, 2014-September 5, 2014.

Description of Current Draft

The Dispersed Generation Resources Standard Drafting Team (DGR SDT) is posting this version of PRC-005 for a 45-day comment period and ballot in the last ten days of the comment period under the new Standards Process Manual (Effective: June 26, 2013). This version is posted for an initial comment and ballot period because changes previously commented on were superseded by non-DGR standard drafting projects that made substantive changes to PRC-005. This version includes all substantive changes recently approved by the NERC Board of Trustees in addition to applicability changes recommended by the DGR SDT.

Anticipated Actions	Anticipated Dates
45-day Formal Comment Period with Parallel Ballot	December 8, 2014 – January 22, 2015
Final ballot	January 2015
BOT adoption	February 2015

Definitions of Terms Used in Standard

This section includes all newly defined or revised terms used in the proposed standard. Terms already defined in the Reliability Standards Glossary of Terms (Glossary) are not repeated here. New or revised definitions listed below become approved when the proposed standard is approved. When the standard becomes effective, this defined term will be removed from the individual standard and added to the Glossary.

None.

A. Introduction

1. **Title:** Protection System, Automatic Reclosing, and Sudden Pressure Relaying Maintenance
2. **Number:** PRC-005-5
3. **Purpose:** To document and implement programs for the maintenance of all Protection Systems, Automatic Reclosing, and Sudden Pressure Relaying affecting the reliability of the Bulk Electric System (BES) so that they are kept in working order.
4. **Applicability:**
 - 4.1. **Functional Entities:**
 - 4.1.1 Transmission Owner
 - 4.1.2 Generator Owner
 - 4.1.3 Distribution Provider
 - 4.2. **Facilities:**
 - 4.2.1 Protection Systems and Sudden Pressure Relaying that are installed for the purpose of detecting Faults on BES Elements (lines, buses, transformers, etc.)
 - 4.2.2 Protection Systems used for underfrequency load-shedding systems installed per ERO underfrequency load-shedding requirements.
 - 4.2.3 Protection Systems used for undervoltage load-shedding systems installed to prevent system voltage collapse or voltage instability for BES reliability.
 - 4.2.4 Protection Systems installed as a Remedial Action Scheme (RAS) for BES reliability.
 - 4.2.5 Protection Systems and Sudden Pressure Relaying for generator Facilities that are part of the BES, for generators not identified through Inclusion I4 of the BES definition, including:
 - 4.2.5.1 Protection Systems that act to trip the generator either directly or via lockout or auxiliary tripping relays.
 - 4.2.5.2 Protection Systems and Sudden Pressure Relaying for generator step-up transformers for generators that are part of the BES.

Protection Systems and Sudden Pressure Relaying for station service or excitation transformers connected to the generator bus of generators which are part of the BES, that act to trip the generator either directly or via lockout or tripping auxiliary relays.

4.2.6 Protection Systems and Sudden Pressure Relaying for the following BES generator Facilities for dispersed power producing resources identified through Inclusion I4 of the BES definition:

4.2.6.1 Protection Systems and Sudden Pressure Relaying Facilities used in aggregating dispersed BES generation from the point where those resources aggregate to greater than 75 MVA to a common point of connection at 100kV or above.

4.2.7 Automatic Reclosing,¹ including:

4.2.7.1 Automatic Reclosing applied on the terminals of Elements connected to the BES bus located at generating plant substations where the total installed gross generating plant capacity is greater than the gross capacity of the largest BES generating unit within the Balancing Authority Area or, if a member of a Reserve Sharing Group, the largest generating unit within the Reserve Sharing Group.²

4.2.7.2 Automatic Reclosing applied on the terminals of all BES Elements at substations one bus away from generating plants specified in Section 4.2.7.1 when the substation is less than 10 circuit-miles from the generating plant substation.

4.2.7.3. Automatic Reclosing applied as an integral part of an RAS specified in Section 4.2.4.

5. Effective Date: See the Implementation Plan for this standard.

6. Definitions Used in this Standard:

Automatic Reclosing – Includes the following Components:

- Reclosing relay
- Control circuitry associated with the reclosing relay.

Sudden Pressure Relaying – A system that trips an interrupting device(s) to isolate the equipment it is monitoring and includes the following Components:

¹ Automatic Reclosing addressed in Section 4.2.7.1 and 4.2.7.3 may be excluded if the equipment owner can demonstrate that a close-in three-phase fault present for twice the normal clearing time (capturing a minimum trip-close-trip time delay) does not result in a total loss of gross generation in the Interconnection exceeding the gross capacity of the largest relevant BES generating unit where the Automatic Reclosing is applied.

² The largest BES generating unit within the Balancing Authority Area or the largest generating unit within the Reserve Sharing Group, as applicable, is subject to change. As a result of such a change, the Automatic Reclosing Components subject to the standard could change effective on the date of such change.

- Fault pressure relay – a mechanical relay or device that detects rapid changes in gas pressure, oil pressure, or oil flow that are indicative of Faults within liquid-filled, wire-wound equipment
- Control circuitry associated with a fault pressure relay

Unresolved Maintenance Issue – A deficiency identified during a maintenance activity that causes the Component to not meet the intended performance, cannot be corrected during the maintenance interval, and requires follow-up corrective action.

Segment – Components of a consistent design standard, or a particular model or type from a single manufacturer that typically share other common elements. Consistent performance is expected across the entire population of a Segment. A Segment must contain at least sixty (60) individual Components.

Component Type –

- Any one of the five specific elements of a Protection System.
- Any one of the two specific elements of Automatic Reclosing.
- Any one of the two specific elements of Sudden Pressure Relaying.

Component – Any individual discrete piece of equipment included in a Protection System, Automatic Reclosing, or Sudden Pressure Relaying.

Countable Event – A failure of a Component requiring repair or replacement, any condition discovered during the maintenance activities in Tables 1-1 through 1-5, Table 3, Tables 4-1 through 4-2, and Table 5, which requires corrective action or a Protection System Misoperation attributed to hardware failure or calibration failure. Misoperations due to product design errors, software errors, relay settings different from specified settings, Protection System Component, Automatic Reclosing, or Sudden Pressure Relaying configuration or application errors are not included in Countable Events.

B. Requirements and Measures

- R1.** Each Transmission Owner, Generator Owner, and Distribution Provider shall establish a Protection System Maintenance Program (PSMP) for its Protection Systems, Automatic Reclosing, and Sudden Pressure Relaying identified in Section 4.2, Facilities. *[Violation Risk Factor: Medium] [Time Horizon: Operations Planning]*

The PSMP shall:

- 1.1.** Identify which maintenance method (time-based, performance-based per PRC-005 Attachment A, or a combination) is used to address each Protection System, Automatic Reclosing, and Sudden Pressure Relaying Component Type. All batteries associated with the station dc supply Component Type of a Protection

System shall be included in a time-based program as described in Table 1-4 and Table 3.

- 1.2.** Include the applicable monitored Component attributes applied to each Protection System, Automatic Reclosing, and Sudden Pressure Relaying Component Type consistent with the maintenance intervals specified in Tables 1-1 through 1-5, Table 2, Table 3, Table 4-1 through 4-2, and Table 5 where monitoring is used to extend the maintenance intervals beyond those specified for unmonitored Protection System, Automatic Reclosing, and Sudden Pressure Relaying Components.
- M1.** Each Transmission Owner, Generator Owner and Distribution Provider shall have a documented Protection System Maintenance Program in accordance with Requirement R1.

For each Protection System, Automatic Reclosing, and Sudden Pressure Relaying Component Type, the documentation shall include the type of maintenance method applied (time-based, performance-based, or a combination of these maintenance methods), and shall include all batteries associated with the station dc supply Component Types in a time-based program as described in Table 1-4 and Table 3. (Part 1.1)

For Component Types that use monitoring to extend the maintenance intervals, the responsible entity(s) shall have evidence for each Protection System, Automatic Reclosing, and Sudden Pressure Relaying Component Type (such as manufacturer's specifications or engineering drawings) of the appropriate monitored Component attributes as specified in Tables 1-1 through 1-5, Table 2, Table 3, Table 4-1 through 4-2, and Table 5. (Part 1.2)
- R2.** Each Transmission Owner, Generator Owner, and Distribution Provider that uses performance-based maintenance intervals in its PSMP shall follow the procedure established in PRC-005 Attachment A to establish and maintain its performance-based intervals. *[Violation Risk Factor: Medium] [Time Horizon: Operations Planning]*
- M2.** Each Transmission Owner, Generator Owner, and Distribution Provider that uses performance-based maintenance intervals shall have evidence that its current performance-based maintenance program(s) is in accordance with Requirement R2, which may include, but is not limited to, Component lists, dated maintenance records, and dated analysis records and results.
- R3.** Each Transmission Owner, Generator Owner, and Distribution Provider that utilizes time-based maintenance program(s) shall maintain its Protection System, Automatic Reclosing, and Sudden Pressure Relaying Components that are included within the time-based maintenance program in accordance with the minimum maintenance activities and maximum maintenance intervals prescribed within Tables 1-1 through 1-5, Table 2, Table 3, Table 4-1 through 4-2, and Table 5. *[Violation Risk Factor: High] [Time Horizon: Operations Planning]*

- M3.** Each Transmission Owner, Generator Owner, and Distribution Provider that utilizes time-based maintenance program(s) shall have evidence that it has maintained its Protection System, Automatic Reclosing, and Sudden Pressure Relaying Components included within its time-based program in accordance with Requirement R3. The evidence may include, but is not limited to, dated maintenance records, dated maintenance summaries, dated check-off lists, dated inspection records, or dated work orders.
- R4.** Each Transmission Owner, Generator Owner, and Distribution Provider that utilizes performance-based maintenance program(s) in accordance with Requirement R2 shall implement and follow its PSMP for its Protection System, Automatic Reclosing, and Sudden Pressure Relaying Components that are included within the performance-based program(s). *[Violation Risk Factor: High] [Time Horizon: Operations Planning]*
- M4.** Each Transmission Owner, Generator Owner, and Distribution Provider that utilizes performance-based maintenance intervals in accordance with Requirement R2 shall have evidence that it has implemented the Protection System Maintenance Program for the Protection System, Automatic Reclosing, and Sudden Pressure Relaying Components included in its performance-based program in accordance with Requirement R4. The evidence may include, but is not limited to, dated maintenance records, dated maintenance summaries, dated check-off lists, dated inspection records, or dated work orders.
- R5.** Each Transmission Owner, Generator Owner, and Distribution Provider shall demonstrate efforts to correct identified Unresolved Maintenance Issues. *[Violation Risk Factor: Medium] [Time Horizon: Operations Planning]*
- M5.** Each Transmission Owner, Generator Owner, and Distribution Provider shall have evidence that it has undertaken efforts to correct identified Unresolved Maintenance Issues in accordance with Requirement R5. The evidence may include, but is not limited to, work orders, replacement Component orders, invoices, project schedules with completed milestones, return material authorizations (RMAs) or purchase orders.

C. Compliance

1. Compliance Monitoring Process

1.1. Compliance Enforcement Authority

As defined in the NERC Rules of Procedure, “Compliance Enforcement Authority” means NERC or the Regional Entity in their respective roles of monitoring and enforcing compliance with the NERC Reliability Standards.

1.2. Evidence Retention

The following evidence retention periods identify the period of time an entity is required to retain specific evidence to demonstrate compliance. For instances where the evidence retention period specified below is shorter than the time

since the last audit, the Compliance Enforcement Authority may ask an entity to provide other evidence to show that it was compliant for the full time period since the last audit.

The Transmission Owner, Generator Owner, and Distribution Provider shall each keep data or evidence to show compliance as identified below unless directed by its Compliance Enforcement Authority to retain specific evidence for a longer period of time as part of an investigation.

For Requirement R1, the Transmission Owner, Generator Owner, and Distribution Provider shall each keep its current dated Protection System Maintenance Program, as well as any superseded versions since the preceding compliance audit, including the documentation that specifies the type of maintenance program applied for each Protection System, Automatic Reclosing, or Sudden Pressure Relaying Component Type.

For Requirement R2, Requirement R3, and Requirement R4, in cases where the interval of the maintenance activity is longer than the audit cycle, the Transmission Owner, Generator Owner, and Distribution Provider shall each keep documentation of the most recent performance of that maintenance activity for the Protection System, Automatic Reclosing, or Sudden Pressure Relaying Component. In cases where the interval of the maintenance activity is shorter than the audit cycle, documentation of all performances (in accordance with the tables) of that maintenance activity for the Protection System, Automatic Reclosing, or Sudden Pressure Relaying Component since the previous scheduled audit date shall be retained.

For Requirement R5 the Transmission Owner, Generator Owner, and Distribution Provider shall each keep documentation of Unresolved Maintenance Issues identified by the entity since the last audit, including all that were resolved since the last audit.

The Compliance Enforcement Authority shall keep the last audit records and all requested and submitted subsequent audit records.

1.3. Compliance Monitoring and Assessment Processes:

- Compliance Audits
- Self-Certifications
- Spot Checking
- Compliance Violation Investigations
- Self-Reporting
- Complaints

1.4. Additional Compliance Information

None

Table of Compliance Elements

Requirement Number	Lower VSL	Moderate VSL	High VSL	Severe VSL
R1	The entity’s PSMP failed to specify whether one Component Type is being addressed by time-based or performance-based maintenance, or a combination of both (Part 1.1).	The entity’s PSMP failed to specify whether two Component Types are being addressed by time-based or performance-based maintenance, or a combination of both (Part 1.1).	<p>The entity’s PSMP failed to specify whether three Component Types are being addressed by time-based or performance-based maintenance, or a combination of both. (Part 1.1).</p> <p>OR</p> <p>The entity’s PSMP failed to include the applicable monitoring attributes applied to each Component Type consistent with the maintenance intervals specified in Tables 1-1 through 1-5, Table 2, Table 3, Tables 4-1 through 4-2, and Table 5 where monitoring is used to extend the maintenance intervals beyond those specified for unmonitored Components (Part 1.2).</p>	<p>The entity failed to establish a PSMP.</p> <p>OR</p> <p>The entity’s PSMP failed to specify whether four or more Component Types are being addressed by time-based or performance-based maintenance, or a combination of both (Part 1.1).</p> <p>OR</p> <p>The entity’s PSMP failed to include applicable station batteries in a time-based program (Part 1.1).</p>
R2	The entity uses performance-based maintenance intervals in its PSMP but failed to reduce Countable Events to no more than 4% within three years.	NA	The entity uses performance-based maintenance intervals in its PSMP but failed to reduce Countable Events to no more than 4% within four years.	<p>The entity uses performance-based maintenance intervals in its PSMP but:</p> <ol style="list-style-type: none"> 1) Failed to establish the technical justification described within Requirement R2 for the initial use of the performance-based PSMP <p>OR</p> <ol style="list-style-type: none"> 2) Failed to reduce Countable Events to no more than 4% within five years <p>OR</p>

Requirement Number	Lower VSL	Moderate VSL	High VSL	Severe VSL
				3) Maintained a Segment with less than 60 Components OR 4) Failed to: <ul style="list-style-type: none"> • Annually update the list of Components, OR • Annually perform maintenance on the greater of 5% of the Segment population or 3 Components, OR • Annually analyze the program activities and results for each Segment.
R3	For Components included within a time-based maintenance program, the entity failed to maintain 5% or less of the total Components included within a specific Component Type in accordance with the minimum maintenance activities and maximum maintenance intervals prescribed within Tables 1-1 through 1-5, Table 2, Table 3, Tables 4-1 through 4-2, and Table 5.	For Components included within a time-based maintenance program, the entity failed to maintain more than 5% but 10% or less of the total Components included within a specific Component Type in accordance with the minimum maintenance activities and maximum maintenance intervals prescribed within Tables 1-1 through 1-5, Table 2, Table 3, Tables 4-1 through 4-2, and Table 5.	For Components included within a time-based maintenance program, the entity failed to maintain more than 10% but 15% or less of the total Components included within a specific Component Type in accordance with the minimum maintenance activities and maximum maintenance intervals prescribed within Tables 1-1 through 1-5, Table 2, Table 3, Tables 4-1 through 4-2, and Table 5.	For Components included within a time-based maintenance program, the entity failed to maintain more than 15% of the total Components included within a specific Component Type in accordance with the minimum maintenance activities and maximum maintenance intervals prescribed within Tables 1-1 through 1-5, Table 2, Table 3, Tables 4-1 through 4-2, and Table 5.

Requirement Number	Lower VSL	Moderate VSL	High VSL	Severe VSL
R4	For Components included within a performance-based maintenance program, the entity failed to maintain 5% or less of the annual scheduled maintenance for a specific Component Type in accordance with their performance-based PSMP.	For Components included within a performance-based maintenance program, the entity failed to maintain more than 5% but 10% or less of the annual scheduled maintenance for a specific Component Type in accordance with their performance-based PSMP.	For Components included within a performance-based maintenance program, the entity failed to maintain more than 10% but 15% or less of the annual scheduled maintenance for a specific Component Type in accordance with their performance-based PSMP.	For Components included within a performance-based maintenance program, the entity failed to maintain more than 15% of the annual scheduled maintenance for a specific Component Type in accordance with their performance-based PSMP.
R5	The entity failed to undertake efforts to correct 5 or fewer identified Unresolved Maintenance Issues.	The entity failed to undertake efforts to correct greater than 5 but less than or equal to 10 identified Unresolved Maintenance Issues.	The entity failed to undertake efforts to correct greater than 10 but less than or equal to 15 identified Unresolved Maintenance Issues.	The entity failed to undertake efforts to correct greater than 15 identified Unresolved Maintenance Issues.

D. Regional Variances

None.

E. Interpretations

None.

Supplemental Reference Documents

The following documents present a detailed discussion about determination of maintenance intervals and other useful information regarding establishment of a maintenance program.

1. *Supplementary Reference and FAQ - PRC-005-4 Protection System Maintenance*, Protection System Maintenance and Testing Standard Drafting Team (April 2014)
2. *Considerations for Maintenance and Testing of Auto-reclosing Schemes*, NERC System Analysis and Modeling Subcommittee, and NERC System Protection and Control Subcommittee (November 2012)
3. *Sudden Pressure Relays and Other Devices that Respond to Non-Electrical Quantities – SPCS Input for Standard Development in Response to FERC Order No. 758*, NERC System Protection and Control Subcommittee (December 2013)

Version History^[KS1]

Version	Date	Action	Change Tracking
0	April 1, 2005	Effective Date	New
1	December 1, 2005	<ol style="list-style-type: none"> 1. Changed incorrect use of certain hyphens (-) to “en dash” (–) and “em dash (—).” 2. Added “periods” to items where appropriate. 3. Changed “Timeframe” to “Time Frame” in item D, 1.2. 	01/20/05
1a	February 17, 2011	Added Appendix 1 - Interpretation regarding applicability of standard to protection of radially connected transformers	Project 2009-17 interpretation
1a	February 17, 2011	Adopted by Board of Trustees	
1a	September 26, 2011	FERC Order issued approving interpretation of R1 and R2 (FERC’s Order is effective as of September 26, 2011)	

1b	February 3, 2012	FERC Order issued approving interpretation of R1, R1.1, and R1.2 (FERC's Order dated March 14, 2012). Updated version from 1a to 1b.	Project 2009-10 Interpretation
1.1b	April 23, 2012	Updated standard version to 1.1b to reflect FERC approval of PRC-005-1b.	Revision under Project 2010-07
1.1b	May 9, 2012	PRC-005-1.1b was adopted by the Board of Trustees as part of Project 2010-07 (Generator Requirements at the Transmission Interface).	
2	November 7, 2012	Adopted by Board of Trustees	Project 2007-17 - Complete revision, absorbing maintenance requirements from PRC-005-1.1b, PRC-008-0, PRC-011-0, PRC-017-0
2	October 17, 2013	Errata Change: The Standards Committee approved an errata change to the implementation plan for PRC-005-2 to add the phrase "or as otherwise made effective pursuant to the laws applicable to such ERO governmental authorities;" to the second sentence under the "Retirement of Existing	
2(i)	November 13, 2014	Adopted by the NERC Board of Trustees	
2(ii)	November 13, 2014	Adopted by the NERC Board of Trustees	

3	November 7, 2013	Adopted by the NERC Board of Trustees	Revised to address the FERC directive in Order No.758 to include Automatic Reclosing in maintenance programs.
3	February 12, 2014	Approved by the Standards Committee	Errata changes to correct capitalization of defined terms (no change to numbering of standard as a result)
3(i)	November 13, 2014	Adopted by the NERC Board of Trustees	
3(ii)	November 13, 2014	Adopted by the NERC Board of Trustees	
4	November 13, 2014	Adopted by the NERC Board of Trustees	Project 2007-17.3 – Revised to address the FERC directive in Order No. 758 to include sudden pressure relays in maintenance programs.

Table 1-1 Component Type - Protective Relay Excluding distributed UFLS and distributed UVLS (see Table 3)		
Component Attributes	Maximum Maintenance Interval ³	Maintenance Activities
Any unmonitored protective relay not having all the monitoring attributes of a category below.	6 Calendar Years	For all unmonitored relays: <ul style="list-style-type: none"> • Verify that settings are as specified For non-microprocessor relays: <ul style="list-style-type: none"> • Test and, if necessary calibrate For microprocessor relays: <ul style="list-style-type: none"> • Verify operation of the relay inputs and outputs that are essential to proper functioning of the Protection System. • Verify acceptable measurement of power system input values.
Monitored microprocessor protective relay with the following: <ul style="list-style-type: none"> • Internal self-diagnosis and alarming (see Table 2). • Voltage and/or current waveform sampling three or more times per power cycle, and conversion of samples to numeric values for measurement calculations by microprocessor electronics. • Alarming for power supply failure (see Table 2). 	12 Calendar Years	Verify: <ul style="list-style-type: none"> • Settings are as specified. • Operation of the relay inputs and outputs that are essential to proper functioning of the Protection System. • Acceptable measurement of power system input values.

³ For the tables in this standard, a calendar year starts on the first day of a new year (January 1) after a maintenance activity has been completed. For the tables in this standard, a calendar month starts on the first day of the first month after a maintenance activity has been completed.

Table 1-1 Component Type - Protective Relay Excluding distributed UFLS and distributed UVLS (see Table 3)		
Component Attributes	Maximum Maintenance Interval ³	Maintenance Activities
Monitored microprocessor protective relay with preceding row attributes and the following: <ul style="list-style-type: none"> • Ac measurements are continuously verified by comparison to an independent ac measurement source, with alarming for excessive error (See Table 2). • Some or all binary or status inputs and control outputs are monitored by a process that continuously demonstrates ability to perform as designed, with alarming for failure (See Table 2). • Alarming for change of settings (See Table 2). 	12 Calendar Years	Verify only the unmonitored relay inputs and outputs that are essential to proper functioning of the Protection System.

Table 1-2 Component Type - Communications Systems Excluding distributed UFLS and distributed UVLS (see Table 3)		
Component Attributes	Maximum Maintenance Interval	Maintenance Activities
Any unmonitored communications system necessary for correct operation of protective functions, and not having all the monitoring attributes of a category below.	4 Calendar Months	Verify that the communications system is functional.
	6 Calendar Years	Verify that the communications system meets performance criteria pertinent to the communications technology applied (e.g. signal level, reflected power, or data error rate). Verify operation of communications system inputs and outputs that are essential to proper functioning of the Protection System.
Any communications system with continuous monitoring or periodic automated testing for the presence of the channel function, and alarming for loss of function (See Table 2).	12 Calendar Years	Verify that the communications system meets performance criteria pertinent to the communications technology applied (e.g. signal level, reflected power, or data error rate). Verify operation of communications system inputs and outputs that are essential to proper functioning of the Protection System.
Any communications system with all of the following: <ul style="list-style-type: none"> • Continuous monitoring or periodic automated testing for the performance of the channel using criteria pertinent to the communications technology applied (e.g. signal level, reflected power, or data error rate, and alarming for excessive performance degradation). (See Table 2) • Some or all binary or status inputs and control outputs are monitored by a process that continuously demonstrates ability to perform as designed, with alarming for failure (See Table 2). 	12 Calendar Years	Verify only the unmonitored communications system inputs and outputs that are essential to proper functioning of the Protection System

Table 1-3 Component Type - Voltage and Current Sensing Devices Providing Inputs to Protective Relays Excluding distributed UFLS and distributed UVLS (see Table 3)		
Component Attributes	Maximum Maintenance Interval	Maintenance Activities
Any voltage and current sensing devices not having monitoring attributes of the category below.	12 Calendar Years	Verify that current and voltage signal values are provided to the protective relays.
Voltage and Current Sensing devices connected to microprocessor relays with AC measurements are continuously verified by comparison of sensing input value, as measured by the microprocessor relay, to an independent ac measurement source, with alarming for unacceptable error or failure (see Table 2).	No periodic maintenance specified	None.

Table 1-4(a) Component Type – Protection System Station dc Supply Using Vented Lead-Acid (VLA) Batteries Excluding distributed UFLS and distributed UVLS (see Table 3)		
Protection System Station dc supply used only for non-BES interrupting devices for RAS, non-distributed UFLS systems, or non-distributed UVLS systems is excluded (see Table 1-4(e)).		
Component Attributes	Maximum Maintenance Interval	Maintenance Activities
Protection System Station dc supply using Vented Lead-Acid (VLA) batteries not having monitoring attributes of Table 1-4(f).	4 Calendar Months	Verify: <ul style="list-style-type: none"> • Station dc supply voltage Inspect: <ul style="list-style-type: none"> • Electrolyte level • For unintentional grounds
	18 Calendar Months	Verify: <ul style="list-style-type: none"> • Float voltage of battery charger • Battery continuity • Battery terminal connection resistance • Battery intercell or unit-to-unit connection resistance Inspect: <ul style="list-style-type: none"> • Cell condition of all individual battery cells where cells are visible – or measure battery cell/unit internal ohmic values where the cells are not visible • Physical condition of battery rack

<p style="text-align: center;">Table 1-4(a) Component Type – Protection System Station dc Supply Using Vented Lead-Acid (VLA) Batteries Excluding distributed UFLS and distributed UVLS (see Table 3)</p> <p style="text-align: center;">Protection System Station dc supply used only for non-BES interrupting devices for RAS, non-distributed UFLS systems, or non-distributed UVLS systems is excluded (see Table 1-4(e)).</p>		
Component Attributes	Maximum Maintenance Interval	Maintenance Activities
	18 Calendar Months -or- 6 Calendar Years	Verify that the station battery can perform as manufactured by evaluating cell/unit measurements indicative of battery performance (e.g. internal ohmic values or float current) against the station battery baseline. -or- Verify that the station battery can perform as manufactured by conducting a performance or modified performance capacity test of the entire battery bank.

Table 1-4(b) Component Type – Protection System Station dc Supply Using Valve-Regulated Lead-Acid (VRLA) Batteries Excluding distributed UFLS and distributed UVLS (see Table 3)		
Protection System Station dc supply used only for non-BES interrupting devices for RAS, non-distributed UFLS systems, or non-distributed UVLS systems is excluded (see Table 1-4(e)).		
Component Attributes	Maximum Maintenance Interval	Maintenance Activities
Protection System Station dc supply with Valve Regulated Lead-Acid (VRLA) batteries not having monitoring attributes of Table 1-4(f).	4 Calendar Months	Verify: <ul style="list-style-type: none"> • Station dc supply voltage Inspect: <ul style="list-style-type: none"> • For unintentional grounds
	6 Calendar Months	Inspect: <ul style="list-style-type: none"> • Condition of all individual units by measuring battery cell/unit internal ohmic values.
	18 Calendar Months	Verify: <ul style="list-style-type: none"> • Float voltage of battery charger • Battery continuity • Battery terminal connection resistance • Battery intercell or unit-to-unit connection resistance Inspect: <ul style="list-style-type: none"> • Physical condition of battery rack

<p style="text-align: center;">Table 1-4(b) Component Type – Protection System Station dc Supply Using Valve-Regulated Lead-Acid (VRLA) Batteries Excluding distributed UFLS and distributed UVLS (see Table 3)</p> <p style="text-align: center;">Protection System Station dc supply used only for non-BES interrupting devices for RAS, non-distributed UFLS systems, or non-distributed UVLS systems is excluded (see Table 1-4(e)).</p>		
Component Attributes	Maximum Maintenance Interval	Maintenance Activities
	6 Calendar Months -or- 3 Calendar Years	Verify that the station battery can perform as manufactured by evaluating cell/unit measurements indicative of battery performance (e.g. internal ohmic values or float current) against the station battery baseline. -or- Verify that the station battery can perform as manufactured by conducting a performance or modified performance capacity test of the entire battery bank.

Table 1-4(c) Component Type – Protection System Station dc Supply Using Nickel-Cadmium (NiCad) Batteries Excluding distributed UFLS and distributed UVLS (see Table 3)		
Protection System Station dc supply used only for non-BES interrupting devices for RAS, non-distributed UFLS system, or non-distributed UVLS systems is excluded (see Table 1-4(e)).		
Component Attributes	Maximum Maintenance Interval	Maintenance Activities
Protection System Station dc supply Nickel-Cadmium (NiCad) batteries not having monitoring attributes of Table 1-4(f).	4 Calendar Months	Verify: <ul style="list-style-type: none"> • Station dc supply voltage Inspect: <ul style="list-style-type: none"> • Electrolyte level • For unintentional grounds
	18 Calendar Months	Verify: <ul style="list-style-type: none"> • Float voltage of battery charger • Battery continuity • Battery terminal connection resistance • Battery intercell or unit-to-unit connection resistance Inspect: <ul style="list-style-type: none"> • Cell condition of all individual battery cells. • Physical condition of battery rack

Table 1-4(c) Component Type – Protection System Station dc Supply Using Nickel-Cadmium (NiCad) Batteries Excluding distributed UFLS and distributed UVLS (see Table 3)		
Protection System Station dc supply used only for non-BES interrupting devices for RAS, non-distributed UFLS system, or non-distributed UVLS systems is excluded (see Table 1-4(e)).		
Component Attributes	Maximum Maintenance Interval	Maintenance Activities
	6 Calendar Years	Verify that the station battery can perform as manufactured by conducting a performance or modified performance capacity test of the entire battery bank.

Table 1-4(d) Component Type – Protection System Station dc Supply Using Non Battery Based Energy Storage Excluding distributed UFLS and distributed UVLS (see Table 3)		
Protection System Station dc supply used only for non-BES interrupting devices for RAS, non-distributed UFLS system, or non-distributed UVLS systems is excluded (see Table 1-4(e)).		
Component Attributes	Maximum Maintenance Interval	Maintenance Activities
Any Protection System station dc supply not using a battery and not having monitoring attributes of Table 1-4(f).	4 Calendar Months	Verify: <ul style="list-style-type: none"> • Station dc supply voltage Inspect: <ul style="list-style-type: none"> • For unintentional grounds
	18 Calendar Months	Inspect: Condition of non-battery based dc supply
	6 Calendar Years	Verify that the dc supply can perform as manufactured when ac power is not present.

Table 1-4(e) Component Type – Protection System Station dc Supply for non-BES Interrupting Devices for RAS, non-distributed UFLS, and non-distributed UVLS systems		
Component Attributes	Maximum Maintenance Interval	Maintenance Activities
Any Protection System dc supply used for tripping only non-BES interrupting devices as part of a RAS, non-distributed UFLS, or non-distributed UVLS system and not having monitoring attributes of Table 1-4(f).	When control circuits are verified (See Table 1-5)	Verify Station dc supply voltage.

Table 1-4(f) Exclusions for Protection System Station dc Supply Monitoring Devices and Systems		
Component Attributes	Maximum Maintenance Interval	Maintenance Activities
Any station dc supply with high and low voltage monitoring and alarming of the battery charger voltage to detect charger overvoltage and charger failure (See Table 2).	No periodic maintenance specified	No periodic verification of station dc supply voltage is required.
Any battery based station dc supply with electrolyte level monitoring and alarming in every cell (See Table 2).		No periodic inspection of the electrolyte level for each cell is required.
Any station dc supply with unintentional dc ground monitoring and alarming (See Table 2).		No periodic inspection of unintentional dc grounds is required.
Any station dc supply with charger float voltage monitoring and alarming to ensure correct float voltage is being applied on the station dc supply (See Table 2).		No periodic verification of float voltage of battery charger is required.
Any battery based station dc supply with monitoring and alarming of battery string continuity (See Table 2).		No periodic verification of the battery continuity is required.
Any battery based station dc supply with monitoring and alarming of the intercell and/or terminal connection detail resistance of the entire battery (See Table 2).		No periodic verification of the intercell and terminal connection resistance is required.
Any Valve Regulated Lead-Acid (VRLA) or Vented Lead-Acid (VLA) station battery with internal ohmic value or float current monitoring and alarming, and evaluating present values relative to baseline internal ohmic values for every cell/unit (See Table 2).		No periodic evaluation relative to baseline of battery cell/unit measurements indicative of battery performance is required to verify the station battery can perform as manufactured.
Any Valve Regulated Lead-Acid (VRLA) or Vented Lead-Acid (VLA) station battery with monitoring and alarming of each cell/unit internal ohmic value (See Table 2).		No periodic inspection of the condition of all individual units by measuring battery cell/unit internal ohmic values of a station VRLA or Vented Lead-Acid (VLA) battery is required.

Table 1-5 Component Type - Control Circuitry Associated With Protective Functions Excluding distributed UFLS and distributed UVLS (see Table 3), Automatic Reclosing (see Table 4), and Sudden Pressure Relaying (see Table 5) Note: Table requirements apply to all Control Circuitry Components of Protection Systems, and RAS except as noted.		
Component Attributes	Maximum Maintenance Interval	Maintenance Activities
Trip coils or actuators of circuit breakers, interrupting devices, or mitigating devices (regardless of any monitoring of the control circuitry).	6 Calendar Years	Verify that each trip coil is able to operate the circuit breaker, interrupting device, or mitigating device.
Electromechanical lockout devices which are directly in a trip path from the protective relay to the interrupting device trip coil (regardless of any monitoring of the control circuitry).	6 Calendar Years	Verify electrical operation of electromechanical lockout devices.
Unmonitored control circuitry associated with RAS. (See Table 4-2(b) for RAS which include Automatic Reclosing.)	12 Calendar Years	Verify all paths of the control circuits essential for proper operation of the RAS.
Unmonitored control circuitry associated with protective functions inclusive of all auxiliary relays.	12 Calendar Years	Verify all paths of the trip circuits inclusive of all auxiliary relays through the trip coil(s) of the circuit breakers or other interrupting devices.
Control circuitry associated with protective functions and/or RAS whose integrity is monitored and alarmed (See Table 2).	No periodic maintenance specified	None.

<p align="center">Table 2 – Alarming Paths and Monitoring</p> <p align="center">In Tables 1-1 through 1-5, Table 3, Tables 4-1 through 4-2, and Table 5 alarm attributes used to justify extended maximum maintenance intervals and/or reduced maintenance activities are subject to the following maintenance requirements</p>		
Component Attributes	Maximum Maintenance Interval	Maintenance Activities
<p>Any alarm path through which alarms in Tables 1-1 through 1-5, Table 3, Tables 4-1 through 4-2, and Table 5 are conveyed from the alarm origin to the location where corrective action can be initiated, and not having all the attributes of the “Alarm Path with monitoring” category below.</p> <p>Alarms are reported within 24 hours of detection to a location where corrective action can be initiated.</p>	12 Calendar Years	Verify that the alarm path conveys alarm signals to a location where corrective action can be initiated.
<p>Alarm Path with monitoring:</p> <p>The location where corrective action is taken receives an alarm within 24 hours for failure of any portion of the alarming path from the alarm origin to the location where corrective action can be initiated.</p>	No periodic maintenance specified	None.

Table 3 Maintenance Activities and Intervals for distributed UFLS and distributed UVLS Systems		
Component Attributes	Maximum Maintenance Interval	Maintenance Activities
Any unmonitored protective relay not having all the monitoring attributes of a category below.	6 Calendar Years	<p>Verify that settings are as specified.</p> <p>For non-microprocessor relays:</p> <ul style="list-style-type: none"> • Test and, if necessary calibrate. <p>For microprocessor relays:</p> <ul style="list-style-type: none"> • Verify operation of the relay inputs and outputs that are essential to proper functioning of the Protection System. • Verify acceptable measurement of power system input values.
<p>Monitored microprocessor protective relay with the following:</p> <ul style="list-style-type: none"> • Internal self-diagnosis and alarming (See Table 2). • Voltage and/or current waveform sampling three or more times per power cycle, and conversion of samples to numeric values for measurement calculations by microprocessor electronics. <p>Alarming for power supply failure (See Table 2).</p>	12 Calendar Years	<p>Verify:</p> <ul style="list-style-type: none"> • Settings are as specified. • Operation of the relay inputs and outputs that are essential to proper functioning of the Protection System. • Acceptable measurement of power system input values
<p>Monitored microprocessor protective relay with preceding row attributes and the following:</p> <ul style="list-style-type: none"> • Ac measurements are continuously verified by comparison to an independent ac measurement source, with alarming for excessive error (See Table 2). 	12 Calendar Years	<p>Verify only the unmonitored relay inputs and outputs that are essential to proper functioning of the Protection System.</p>

Table 3 Maintenance Activities and Intervals for distributed UFLS and distributed UVLS Systems		
Component Attributes	Maximum Maintenance Interval	Maintenance Activities
<ul style="list-style-type: none"> Some or all binary or status inputs and control outputs are monitored by a process that continuously demonstrates ability to perform as designed, with alarming for failure (See Table 2). Alarming for change of settings (See Table 2).		
Voltage and/or current sensing devices associated with UFLS or UVLS systems.	12 Calendar Years	Verify that current and/or voltage signal values are provided to the protective relays.
Protection System dc supply for tripping non-BES interrupting devices used only for a UFLS or UVLS system.	12 Calendar Years	Verify Protection System dc supply voltage.
Control circuitry between the UFLS or UVLS relays and electromechanical lockout and/or tripping auxiliary devices (excludes non-BES interrupting device trip coils).	12 Calendar Years	Verify the path from the relay to the lockout and/or tripping auxiliary relay (including essential supervisory logic).
Electromechanical lockout and/or tripping auxiliary devices associated only with UFLS or UVLS systems (excludes non-BES interrupting device trip coils).	12 Calendar Years	Verify electrical operation of electromechanical lockout and/or tripping auxiliary devices.
Control circuitry between the electromechanical lockout and/or tripping auxiliary devices and the non-BES interrupting devices in UFLS or UVLS systems, or between UFLS or UVLS relays (with no interposing electromechanical lockout or auxiliary device) and the non-BES interrupting devices (excludes non-BES interrupting device trip coils).	No periodic maintenance specified	None.
Trip coils of non-BES interrupting devices in UFLS or UVLS systems.	No periodic maintenance specified	None.

Table 4-1 Maintenance Activities and Intervals for Automatic Reclosing Components Component Type – Reclosing Relay		
Component Attributes	Maximum Maintenance Interval	Maintenance Activities
Any unmonitored reclosing relay not having all the monitoring attributes of a category below.	6 Calendar Years	Verify that settings are as specified. For non-microprocessor relays: <ul style="list-style-type: none"> • Test and, if necessary calibrate For microprocessor relays: <ul style="list-style-type: none"> • Verify operation of the relay inputs and outputs that are essential to proper functioning of the Automatic Reclosing.
Monitored microprocessor reclosing relay with the following: <ul style="list-style-type: none"> • Internal self-diagnosis and alarming (See Table 2). • Alarming for power supply failure (See Table 2). 	12 Calendar Years	Verify: <ul style="list-style-type: none"> • Settings are as specified. • Operation of the relay inputs and outputs that are essential to proper functioning of the Automatic Reclosing.

Table 4-2(a) Maintenance Activities and Intervals for Automatic Reclosing Components Component Type – Control Circuitry Associated with Reclosing Relays that are NOT an Integral Part of an RAS		
Component Attributes	Maximum Maintenance Interval	Maintenance Activities
Unmonitored Control circuitry associated with Automatic Reclosing that is not an integral part of an RAS.	12 Calendar Years	Verify that Automatic Reclosing, upon initiation, does not issue a premature closing command to the close circuitry.
Control circuitry associated with Automatic Reclosing that is not part of an RAS and is monitored and alarmed for conditions that would result in a premature closing command. (See Table 2)	No periodic maintenance specified	None.

Table 4-2(b) Maintenance Activities and Intervals for Automatic Reclosing Components Component Type – Control Circuitry Associated with Reclosing Relays that ARE an Integral Part of an RAS		
Component Attributes	Maximum Maintenance Interval	Maintenance Activities
Close coils or actuators of circuit breakers or similar devices that are used in conjunction with Automatic Reclosing as part of an RAS (regardless of any monitoring of the control circuitry).	6 Calendar Years	Verify that each close coil or actuator is able to operate the circuit breaker or mitigating device.
Unmonitored close control circuitry associated with Automatic Reclosing used as an integral part of an RAS.	12 Calendar Years	Verify all paths of the control circuits associated with Automatic Reclosing that are essential for proper operation of the RAS.
Control circuitry associated with Automatic Reclosing that is an integral part of an RAS whose integrity is monitored and alarmed. (See Table 2)	No periodic maintenance specified	None.

<p style="text-align: center;">Table 5 Maintenance Activities and Intervals for Sudden Pressure Relaying</p> <p style="text-align: center;">Note: In cases where Components of Sudden Pressure Relaying are common to Components listed in Table 1-5, the Components only need to be tested once during a distinct maintenance interval.</p>		
Component Attributes	Maximum Maintenance Interval	Maintenance Activities
Any fault pressure relay.	6 Calendar Years	Verify the pressure or flow sensing mechanism is operable.
Electromechanical lockout devices which are directly in a trip path from the fault pressure relay to the interrupting device trip coil (regardless of any monitoring of the control circuitry).	6 Calendar Years	Verify electrical operation of electromechanical lockout devices.
Unmonitored control circuitry associated with Sudden Pressure Relaying.	12 Calendar Years	Verify all paths of the trip circuits inclusive of all auxiliary relays through the trip coil(s) of the circuit breakers or other interrupting devices.
Control circuitry associated with Sudden Pressure Relaying whose integrity is monitored and alarmed (See Table 2).	No periodic maintenance specified	None.

Rationale:

During development of this standard, text boxes were embedded within the standard to explain the rationale for various parts of the standard. Upon BOT approval, the text from the rationale text boxes was moved to this section.

Rationale for Applicability Section:

This section does not reflect the applicability changes that will be proposed by the Project 2014-01 Standards Applicability for Dispersed Generation Resources standards drafting team. The changes in this posted version and those being made by the Project 2014-01 standards drafting team do not overlap.

Additionally, to align with ongoing NERC standards development in Project 2010-05.2: Special Protection Systems, the term “Special Protection Systems” in PRC-005-4 was replaced by the term “Remedial Action Schemes.” These terms are synonymous in the NERC Glossary of Terms.

Rationale for the deletion of part of the definition of Component:

The SDT determined that it was explanatory in nature and adequately addressed in the Supplementary Reference and FAQ Document.

Rationale for R3 Part 3.1:

In the last posting, the SDT included language in the standard that was originally in the implementation plan that required completion of maintenance activities within three years for newly-identified Automatic Reclosing Components following a notification under Requirement R6, which has been removed. After further discussion, the SDT determined that a separate shorter timeframe for maintenance of newly-identified Automatic Reclosing Components created unnecessary complication within the standard. The SDT agreed that entities should be responsible for maintaining the Automatic Reclosing Components subject to the standard, whether existing, newly added or newly within scope based on a change in the largest generating unit in the BA or, if a member of a Reserve Sharing Group, the largest generating unit within the Reserve Sharing Group according to the timeframes in the maintenance tables. Therefore, 3.1 and its subparts have been removed and have not been reinserted into the implementation plan.

Rationale for R4 Part 4.1:

In the last posting, the SDT included language in the standard that was originally in the implementation plan that required completion of maintenance activities within three years for newly-identified Automatic Reclosing Components following a notification under Requirement R6, which has been removed. After further discussion, the SDT determined that a separate shorter timeframe for maintenance of newly-identified Automatic Reclosing Components created unnecessary complication within the standard. The SDT agreed that entities should be responsible for maintaining the Automatic Reclosing Components subject to the standard, whether existing, newly added or newly within scope based on a change in the largest generating unit in the BA or, if a member of a Reserve Sharing Group, the largest generating

unit within the Reserve Sharing Group according to the timeframes in the maintenance tables. Therefore, 4.1 and its subparts have been removed and have not been reinserted into the implementation plan.

PRC-005 — Attachment A

Criteria for a Performance-Based Protection System Maintenance Program

Purpose: To establish a technical basis for initial and continued use of a performance-based Protection System Maintenance Program (PSMP).

To establish the technical justification for the initial use of a performance-based PSMP:

1. Develop a list with a description of Components included in each designated Segment, with a minimum Segment population of 60 Components.
2. Maintain the Components in each Segment according to the time-based maximum allowable intervals established in Tables 1-1 through 1-5, Table 3, Tables 4-1 through 4-2, and Table 5 until results of maintenance activities for the Segment are available for a minimum of 30 individual Components of the Segment.
3. Document the maintenance program activities and results for each Segment, including maintenance dates and Countable Events for each included Component.
4. Analyze the maintenance program activities and results for each Segment to determine the overall performance of the Segment and develop maintenance intervals.
5. Determine the maximum allowable maintenance interval for each Segment such that the Segment experiences Countable Events on no more than 4% of the Components within the Segment, for the greater of either the last 30 Components maintained or all Components maintained in the previous year.

To maintain the technical justification for the ongoing use of a performance-based PSMP:

1. At least annually, update the list of Components and Segments and/or description if any changes occur within the Segment.
2. Perform maintenance on the greater of 5% of the Components (addressed in the performance based PSMP) in each Segment or 3 individual Components within the Segment in each year.
3. For the prior year, analyze the maintenance program activities and results for each Segment to determine the overall performance of the Segment.
4. Using the prior year's data, determine the maximum allowable maintenance interval for each Segment such that the Segment experiences Countable Events on no more than 4% of the Components within the Segment, for the greater of either the last 30 Components maintained or all Components maintained in the previous year.

If the Components in a Segment maintained through a performance-based PSMP experience 4% or more Countable Events, develop, document, and implement an action plan to reduce the Countable Events to less than 4% of the Segment population within 3 years.

Standard Development Timeline

This section is maintained by the drafting team during the development of the standard and will be removed when the standard becomes effective.

Development Steps Completed

1. SAR posted for comment November 20, 2013 – December 19, 2013.
2. An earlier draft of this standard was posted for a 45-day comment and ballot period June 12, 2014–July 29, 2014.
3. PRC-005-3(X) passed a final ballot, which was posted for a 10-day ballot period of August 27, 2014-September 5, 2014.

Description of Current Draft

The Dispersed Generation Resources Standard Drafting Team (DGR SDT) is posting this version of PRC-005-~~5~~ for a 45-day comment period and ballot in the last ten days of the comment period under the new Standards Process Manual (Effective: June 26, 2013). This version is posted for an initial comment and ballot period because changes previously commented on were superseded by non-DGR standard drafting projects that made substantive changes to PRC-005. This version includes all substantive changes recently approved by the NERC Board of Trustees in addition to applicability changes recommended by the DGR SDT.

<u>Anticipated Actions</u>	<u>Anticipated Dates</u>
<u>45-day Formal Comment Period with Parallel Ballot</u>	<u>December 8, 2014 – January 22, 2015</u>
<u>Final ballot</u>	<u>January 2015</u>
<u>BOT adoption</u>	<u>February 2015</u>

Definitions of Terms Used in Standard

This section includes all newly defined or revised terms used in the proposed standard. Terms already defined in the Reliability Standards Glossary of Terms (Glossary) are not repeated here. New or revised definitions listed below become approved when the proposed standard is approved. When the standard becomes effective, this defined term will be removed from the individual standard and added to the Glossary.

None.

A. Introduction

1. **Title:** Protection System, Automatic Reclosing, and Sudden Pressure Relaying Maintenance
2. **Number:** PRC-005-45
3. **Purpose:** To document and implement programs for the maintenance of all Protection Systems, Automatic Reclosing, and Sudden Pressure Relaying affecting the reliability of the Bulk Electric System (BES) so that they are kept in working order.

4. **Applicability:**

- 4.1. **Functional Entities:**

- 4.1.1 Transmission Owner
 - 4.1.2 Generator Owner
 - 4.1.3 Distribution Provider

- 4.2. **Facilities:**

- 4.2.1 Protection Systems and Sudden Pressure Relaying that are installed for the purpose of detecting Faults on BES Elements (lines, buses, transformers, etc.)
 - 4.2.2 Protection Systems used for underfrequency load-shedding systems installed per ERO underfrequency load-shedding requirements.
 - 4.2.3 Protection Systems used for undervoltage load-shedding systems installed to prevent system voltage collapse or voltage instability for BES reliability.
 - 4.2.4 Protection Systems installed as a Remedial Action Scheme (RAS) for BES reliability.
 - 4.2.5 Protection Systems and Sudden Pressure Relaying for generator Facilities that are part of the BES, for generators not identified through Inclusion I4 of the BES definition, including:
 - 4.2.5.1 Protection Systems that act to trip the generator either directly or via lockout or auxiliary tripping relays.
 - 4.2.5.2 Protection Systems and Sudden Pressure Relaying for generator step-up transformers for generators that are part of the BES.

~~Protection Systems and Sudden Pressure Relaying for transformers connecting aggregated generation, where the aggregated generation is part of the BES (e.g., transformers connecting facilities such as wind farms to the BES).~~

-Protection Systems and Sudden Pressure Relaying for station service or excitation transformers connected to the generator bus of generators which are part of the BES, that act to trip the generator either directly or via lockout or tripping auxiliary relays.

4.2.6 Protection Systems and Sudden Pressure Relaying for the following BES generator Facilities for dispersed power producing resources identified through Inclusion I4 of the BES definition:

4.2.6.1 Protection Systems and Sudden Pressure Relaying Facilities used in aggregating dispersed BES generation from the point where those resources aggregate to greater than 75 MVA to a common point of connection at 100kV or above.

4.2.6.2.7 Automatic Reclosing,¹ including:

4.2.6.14.2.7.1 Automatic Reclosing applied on the terminals of Elements connected to the BES bus located at generating plant substations where the total installed gross generating plant capacity is greater than the gross capacity of the largest BES generating unit within the Balancing Authority Area or, if a member of a Reserve Sharing Group, the largest generating unit within the Reserve Sharing Group. ²

4.2.6.24.2.7.2 Automatic Reclosing applied on the terminals of all BES Elements at substations one bus away from generating plants specified in Section 4.2.6.7.1 when the substation is less than 10 circuit-miles from the generating plant substation.

4.2.6.7.3. Automatic Reclosing applied as an integral part of an RAS specified in Section 4.2.4.

5. Effective Date: See [the Implementation Plan for this standard.](#)

6. Definitions Used in this Standard:

Automatic Reclosing – Includes the following Components:

¹ Automatic Reclosing addressed in Section 4.2.6.7.1 and 4.2.6.7.2-3 may be excluded if the equipment owner can demonstrate that a close-in three-phase fault present for twice the normal clearing time (capturing a minimum trip-close-trip time delay) does not result in a total loss of gross generation in the Interconnection exceeding the gross capacity of the largest relevant BES generating unit where the Automatic Reclosing is applied.

² The largest BES generating unit within the Balancing Authority Area or the largest generating unit within the Reserve Sharing Group, as applicable, is subject to change. As a result of such a change, the Automatic Reclosing Components subject to the standard could change effective on the date of such change.

- Reclosing relay
- Control circuitry associated with the reclosing relay.

Sudden Pressure Relaying – A system that trips an interrupting device(s) to isolate the equipment it is monitoring and includes the following Components:

- Fault pressure relay – a mechanical relay or device that detects rapid changes in gas pressure, oil pressure, or oil flow that are indicative of Faults within liquid-filled, wire-wound equipment
- Control circuitry associated with a fault pressure relay

Unresolved Maintenance Issue – A deficiency identified during a maintenance activity that causes the Component to not meet the intended performance, cannot be corrected during the maintenance interval, and requires follow-up corrective action.

Segment – Components of a consistent design standard, or a particular model or type from a single manufacturer that typically share other common elements. Consistent performance is expected across the entire population of a Segment. A Segment must contain at least sixty (60) individual Components.

Component Type –

- Any one of the five specific elements of a Protection System.
- Any one of the two specific elements of Automatic Reclosing.
- Any one of the two specific elements of Sudden Pressure Relaying.

Component – Any individual discrete piece of equipment included in a Protection System, Automatic Reclosing, or Sudden Pressure Relaying.

Countable Event – A failure of a Component requiring repair or replacement, any condition discovered during the maintenance activities in Tables 1-1 through 1-5, Table 3, Tables 4-1 through 4-2, and Table 5, which requires corrective action or a Protection System Misoperation attributed to hardware failure or calibration failure. Misoperations due to product design errors, software errors, relay settings different from specified settings, Protection System Component, Automatic Reclosing, or Sudden Pressure Relaying configuration or application errors are not included in Countable Events.

B. Requirements and Measures

- R1.** Each Transmission Owner, Generator Owner, and Distribution Provider shall establish a Protection System Maintenance Program (PSMP) for its Protection Systems, Automatic Reclosing, and Sudden Pressure Relaying identified in Section 4.2, Facilities. *[Violation Risk Factor: Medium] [Time Horizon: Operations Planning]*

The PSMP shall:

- 1.1.** Identify which maintenance method (time-based, performance-based per PRC-005 Attachment A, or a combination) is used to address each Protection System, Automatic Reclosing, and Sudden Pressure Relaying Component Type. All batteries associated with the station dc supply Component Type of a Protection System shall be included in a time-based program as described in Table 1-4 and Table 3.
 - 1.2.** Include the applicable monitored Component attributes applied to each Protection System, Automatic Reclosing, and Sudden Pressure Relaying Component Type consistent with the maintenance intervals specified in Tables 1-1 through 1-5, Table 2, Table 3, Table 4-1 through 4-2, and Table 5 where monitoring is used to extend the maintenance intervals beyond those specified for unmonitored Protection System, Automatic Reclosing, and Sudden Pressure Relaying Components.
- M1.** Each Transmission Owner, Generator Owner and Distribution Provider shall have a documented Protection System Maintenance Program in accordance with Requirement R1.
- For each Protection System, Automatic Reclosing, and Sudden Pressure Relaying Component Type, the documentation shall include the type of maintenance method applied (time-based, performance-based, or a combination of these maintenance methods), and shall include all batteries associated with the station dc supply Component Types in a time-based program as described in Table 1-4 and Table 3. (Part 1.1)
- For Component Types that use monitoring to extend the maintenance intervals, the responsible entity(s) shall have evidence for each Protection System, Automatic Reclosing, and Sudden Pressure Relaying Component Type (such as manufacturer's specifications or engineering drawings) of the appropriate monitored Component attributes as specified in Tables 1-1 through 1-5, Table 2, Table 3, Table 4-1 through 4-2, and Table 5. (Part 1.2)
- R2.** Each Transmission Owner, Generator Owner, and Distribution Provider that uses performance-based maintenance intervals in its PSMP shall follow the procedure established in PRC-005 Attachment A to establish and maintain its performance-based intervals. [*Violation Risk Factor: Medium*] [*Time Horizon: Operations Planning*]
 - M2.** Each Transmission Owner, Generator Owner, and Distribution Provider that uses performance-based maintenance intervals shall have evidence that its current performance-based maintenance program(s) is in accordance with Requirement R2, which may include, but is not limited to, Component lists, dated maintenance records, and dated analysis records and results.
 - R3.** Each Transmission Owner, Generator Owner, and Distribution Provider that utilizes time-based maintenance program(s) shall maintain its Protection System, Automatic

Reclosing, and Sudden Pressure Relaying Components that are included within the time-based maintenance program in accordance with the minimum maintenance activities and maximum maintenance intervals prescribed within Tables 1-1 through 1-5, Table 2, Table 3, Table 4-1 through 4-2, and Table 5. *[Violation Risk Factor: High]*
[Time Horizon: Operations Planning]

- M3.** Each Transmission Owner, Generator Owner, and Distribution Provider that utilizes time-based maintenance program(s) shall have evidence that it has maintained its Protection System, Automatic Reclosing, and Sudden Pressure Relaying Components included within its time-based program in accordance with Requirement R3. The evidence may include, but is not limited to, dated maintenance records, dated maintenance summaries, dated check-off lists, dated inspection records, or dated work orders.
- R4.** Each Transmission Owner, Generator Owner, and Distribution Provider that utilizes performance-based maintenance program(s) in accordance with Requirement R2 shall implement and follow its PSMP for its Protection System, Automatic Reclosing, and Sudden Pressure Relaying Components that are included within the performance-based program(s). *[Violation Risk Factor: High]* *[Time Horizon: Operations Planning]*
- M4.** Each Transmission Owner, Generator Owner, and Distribution Provider that utilizes performance-based maintenance intervals in accordance with Requirement R2 shall have evidence that it has implemented the Protection System Maintenance Program for the Protection System, Automatic Reclosing, and Sudden Pressure Relaying Components included in its performance-based program in accordance with Requirement R4. The evidence may include, but is not limited to, dated maintenance records, dated maintenance summaries, dated check-off lists, dated inspection records, or dated work orders.
- R5.** Each Transmission Owner, Generator Owner, and Distribution Provider shall demonstrate efforts to correct identified Unresolved Maintenance Issues. *[Violation Risk Factor: Medium]* *[Time Horizon: Operations Planning]*
- M5.** Each Transmission Owner, Generator Owner, and Distribution Provider shall have evidence that it has undertaken efforts to correct identified Unresolved Maintenance Issues in accordance with Requirement R5. The evidence may include, but is not limited to, work orders, replacement Component orders, invoices, project schedules with completed milestones, return material authorizations (RMAs) or purchase orders.

C. Compliance

- 1. Compliance Monitoring Process**
 - 1.1. Compliance Enforcement Authority**

As defined in the NERC Rules of Procedure, “Compliance Enforcement Authority” means NERC or the Regional Entity in their respective roles of monitoring and enforcing compliance with the NERC Reliability Standards.

1.2. Evidence Retention

The following evidence retention periods identify the period of time an entity is required to retain specific evidence to demonstrate compliance. For instances where the evidence retention period specified below is shorter than the time since the last audit, the Compliance Enforcement Authority may ask an entity to provide other evidence to show that it was compliant for the full time period since the last audit.

The Transmission Owner, Generator Owner, and Distribution Provider shall each keep data or evidence to show compliance as identified below unless directed by its Compliance Enforcement Authority to retain specific evidence for a longer period of time as part of an investigation.

For Requirement R1, the Transmission Owner, Generator Owner, and Distribution Provider shall each keep its current dated Protection System Maintenance Program, as well as any superseded versions since the preceding compliance audit, including the documentation that specifies the type of maintenance program applied for each Protection System, Automatic Reclosing, or Sudden Pressure Relaying Component Type.

For Requirement R2, Requirement R3, and Requirement R4, in cases where the interval of the maintenance activity is longer than the audit cycle, the Transmission Owner, Generator Owner, and Distribution Provider shall each keep documentation of the most recent performance of that maintenance activity for the Protection System, Automatic Reclosing, or Sudden Pressure Relaying Component. In cases where the interval of the maintenance activity is shorter than the audit cycle, documentation of all performances (in accordance with the tables) of that maintenance activity for the Protection System, Automatic Reclosing, or Sudden Pressure Relaying Component since the previous scheduled audit date shall be retained.

For Requirement R5 the Transmission Owner, Generator Owner, and Distribution Provider shall each keep documentation of Unresolved Maintenance Issues identified by the entity since the last audit, including all that were resolved since the last audit.

The Compliance Enforcement Authority shall keep the last audit records and all requested and submitted subsequent audit records.

1.3. Compliance Monitoring and Assessment Processes:

Compliance Audits

Self-Certifications

Spot Checking

Compliance Violation Investigations

Self-Reporting

Complaints

1.4. Additional Compliance Information

None

Table of Compliance Elements

Requirement Number	Lower VSL	Moderate VSL	High VSL	Severe VSL
R1	The entity’s PSMP failed to specify whether one Component Type is being addressed by time-based or performance-based maintenance, or a combination of both (Part 1.1).	The entity’s PSMP failed to specify whether two Component Types are being addressed by time-based or performance-based maintenance, or a combination of both (Part 1.1).	<p>The entity’s PSMP failed to specify whether three Component Types are being addressed by time-based or performance-based maintenance, or a combination of both. (Part 1.1).</p> <p>OR</p> <p>The entity’s PSMP failed to include the applicable monitoring attributes applied to each Component Type consistent with the maintenance intervals specified in Tables 1-1 through 1-5, Table 2, Table 3, Tables 4-1 through 4-2, and Table 5 where monitoring is used to extend the maintenance intervals beyond those specified for unmonitored Components (Part 1.2).</p>	<p>The entity failed to establish a PSMP.</p> <p>OR</p> <p>The entity’s PSMP failed to specify whether four or more Component Types are being addressed by time-based or performance-based maintenance, or a combination of both (Part 1.1).</p> <p>OR</p> <p>The entity’s PSMP failed to include applicable station batteries in a time-based program (Part 1.1).</p>
R2	The entity uses performance-based maintenance intervals in its PSMP but failed to reduce Countable Events to no more than 4% within three years.	NA	The entity uses performance-based maintenance intervals in its PSMP but failed to reduce Countable Events to no more than 4% within four years.	<p>The entity uses performance-based maintenance intervals in its PSMP but:</p> <ol style="list-style-type: none"> 1) Failed to establish the technical justification described within Requirement R2 for the initial use of the performance-based PSMP <p>OR</p> <ol style="list-style-type: none"> 2) Failed to reduce Countable Events to no more than 4% within five years <p>OR</p>

Requirement Number	Lower VSL	Moderate VSL	High VSL	Severe VSL
				3) Maintained a Segment with less than 60 Components OR 4) Failed to: <ul style="list-style-type: none"> • Annually update the list of Components, OR • Annually perform maintenance on the greater of 5% of the Segment population or 3 Components, OR • Annually analyze the program activities and results for each Segment.
R3	For Components included within a time-based maintenance program, the entity failed to maintain 5% or less of the total Components included within a specific Component Type in accordance with the minimum maintenance activities and maximum maintenance intervals prescribed within Tables 1-1 through 1-5, Table 2, Table 3, Tables 4-1 through 4-2, and Table 5.	For Components included within a time-based maintenance program, the entity failed to maintain more than 5% but 10% or less of the total Components included within a specific Component Type in accordance with the minimum maintenance activities and maximum maintenance intervals prescribed within Tables 1-1 through 1-5, Table 2, Table 3, Tables 4-1 through 4-2, and Table 5.	For Components included within a time-based maintenance program, the entity failed to maintain more than 10% but 15% or less of the total Components included within a specific Component Type in accordance with the minimum maintenance activities and maximum maintenance intervals prescribed within Tables 1-1 through 1-5, Table 2, Table 3, Tables 4-1 through 4-2, and Table 5.	For Components included within a time-based maintenance program, the entity failed to maintain more than 15% of the total Components included within a specific Component Type in accordance with the minimum maintenance activities and maximum maintenance intervals prescribed within Tables 1-1 through 1-5, Table 2, Table 3, Tables 4-1 through 4-2, and Table 5.

Requirement Number	Lower VSL	Moderate VSL	High VSL	Severe VSL
R4	For Components included within a performance-based maintenance program, the entity failed to maintain 5% or less of the annual scheduled maintenance for a specific Component Type in accordance with their performance-based PSMP.	For Components included within a performance-based maintenance program, the entity failed to maintain more than 5% but 10% or less of the annual scheduled maintenance for a specific Component Type in accordance with their performance-based PSMP.	For Components included within a performance-based maintenance program, the entity failed to maintain more than 10% but 15% or less of the annual scheduled maintenance for a specific Component Type in accordance with their performance-based PSMP.	For Components included within a performance-based maintenance program, the entity failed to maintain more than 15% of the annual scheduled maintenance for a specific Component Type in accordance with their performance-based PSMP.
R5	The entity failed to undertake efforts to correct 5 or fewer identified Unresolved Maintenance Issues.	The entity failed to undertake efforts to correct greater than 5 but less than or equal to 10 identified Unresolved Maintenance Issues.	The entity failed to undertake efforts to correct greater than 10 but less than or equal to 15 identified Unresolved Maintenance Issues.	The entity failed to undertake efforts to correct greater than 15 identified Unresolved Maintenance Issues.

D. Regional Variances

None.

E. Interpretations

None.

Supplemental Reference Documents

The following documents present a detailed discussion about determination of maintenance intervals and other useful information regarding establishment of a maintenance program.

1. *Supplementary Reference and FAQ - PRC-005-4 Protection System Maintenance*, Protection System Maintenance and Testing Standard Drafting Team (April 2014)
2. *Considerations for Maintenance and Testing of Auto-reclosing Schemes*, NERC System Analysis and Modeling Subcommittee, and NERC System Protection and Control Subcommittee (November 2012)
3. *Sudden Pressure Relays and Other Devices that Respond to Non-Electrical Quantities – SPCS Input for Standard Development in Response to FERC Order No. 758*, NERC System Protection and Control Subcommittee (December 2013)

Version History^[KS1]

Version	Date	Action	Change Tracking
0	April 1, 2005	Effective Date	New
1	December 1, 2005	<ol style="list-style-type: none"> 1. Changed incorrect use of certain hyphens (-) to “en dash” (–) and “em dash (—).” 2. Added “periods” to items where appropriate. 3. Changed “Timeframe” to “Time Frame” in item D, 1.2. 	01/20/05
1a	February 17, 2011	Added Appendix 1 - Interpretation regarding applicability of standard to protection of radially connected transformers	Project 2009-17 interpretation
1a	February 17, 2011	Adopted by Board of Trustees	
1a	September 26, 2011	FERC Order issued approving interpretation of R1 and R2 (FERC’s Order is effective as of September 26, 2011)	

1b	February 3, 2012	FERC Order issued approving interpretation of R1, R1.1, and R1.2 (FERC's Order dated March 14, 2012). Updated version from 1a to 1b.	Project 2009-10 Interpretation
1.1b	April 23, 2012	Updated standard version to 1.1b to reflect FERC approval of PRC-005-1b.	Revision under Project 2010-07
1.1b	May 9, 2012	PRC-005-1.1b was adopted by the Board of Trustees as part of Project 2010-07 (Generator Requirements at the Transmission Interface).	
2	November 7, 2012	Adopted by Board of Trustees	Project 2007-17 - Complete revision, absorbing maintenance requirements from PRC-005-1.1b, PRC-008-0, PRC-011-0, PRC-017-0
2	October 17, 2013	Errata Change: The Standards Committee approved an errata change to the implementation plan for PRC-005-2 to add the phrase "or as otherwise made effective pursuant to the laws applicable to such ERO governmental authorities;" to the second sentence under the "Retirement of Existing	
2(i)	November 13, 2014	Adopted by the NERC Board of Trustees	
2(ii)	November 13, 2014	Adopted by the NERC Board of Trustees	

3	November 7, 2013	Adopted by the NERC Board of Trustees	Revised to address the FERC directive in Order No.758 to include Automatic Reclosing in maintenance programs.
3	February 12, 2014	Approved by the Standards Committee	Errata changes to correct capitalization of defined terms (no change to numbering of standard as a result)
3(i)	November 13, 2014	Adopted by the NERC Board of Trustees	
3(ii)	November 13, 2014	Adopted by the NERC Board of Trustees	
4	November 13, 2014	Adopted by the NERC Board of Trustees	Project 2007-17.3 – Revised to address the FERC directive in Order No. 758 to include sudden pressure relays in maintenance programs.

Table 1-1 Component Type - Protective Relay Excluding distributed UFLS and distributed UVLS (see Table 3)		
Component Attributes	Maximum Maintenance Interval ³	Maintenance Activities
Any unmonitored protective relay not having all the monitoring attributes of a category below.	6 Calendar Years	For all unmonitored relays: <ul style="list-style-type: none"> • Verify that settings are as specified For non-microprocessor relays: <ul style="list-style-type: none"> • Test and, if necessary calibrate For microprocessor relays: <ul style="list-style-type: none"> • Verify operation of the relay inputs and outputs that are essential to proper functioning of the Protection System. • Verify acceptable measurement of power system input values.
Monitored microprocessor protective relay with the following: <ul style="list-style-type: none"> • Internal self-diagnosis and alarming (see Table 2). • Voltage and/or current waveform sampling three or more times per power cycle, and conversion of samples to numeric values for measurement calculations by microprocessor electronics. • Alarming for power supply failure (see Table 2). 	12 Calendar Years	Verify: <ul style="list-style-type: none"> • Settings are as specified. • Operation of the relay inputs and outputs that are essential to proper functioning of the Protection System. • Acceptable measurement of power system input values.

³ For the tables in this standard, a calendar year starts on the first day of a new year (January 1) after a maintenance activity has been completed. For the tables in this standard, a calendar month starts on the first day of the first month after a maintenance activity has been completed.

Table 1-1 Component Type - Protective Relay Excluding distributed UFLS and distributed UVLS (see Table 3)		
Component Attributes	Maximum Maintenance Interval ³	Maintenance Activities
Monitored microprocessor protective relay with preceding row attributes and the following: <ul style="list-style-type: none"> • Ac measurements are continuously verified by comparison to an independent ac measurement source, with alarming for excessive error (See Table 2). • Some or all binary or status inputs and control outputs are monitored by a process that continuously demonstrates ability to perform as designed, with alarming for failure (See Table 2). • Alarming for change of settings (See Table 2). 	12 Calendar Years	Verify only the unmonitored relay inputs and outputs that are essential to proper functioning of the Protection System.

Table 1-2 Component Type - Communications Systems Excluding distributed UFLS and distributed UVLS (see Table 3)		
Component Attributes	Maximum Maintenance Interval	Maintenance Activities
Any unmonitored communications system necessary for correct operation of protective functions, and not having all the monitoring attributes of a category below.	4 Calendar Months	Verify that the communications system is functional.
	6 Calendar Years	Verify that the communications system meets performance criteria pertinent to the communications technology applied (e.g. signal level, reflected power, or data error rate). Verify operation of communications system inputs and outputs that are essential to proper functioning of the Protection System.
Any communications system with continuous monitoring or periodic automated testing for the presence of the channel function, and alarming for loss of function (See Table 2).	12 Calendar Years	Verify that the communications system meets performance criteria pertinent to the communications technology applied (e.g. signal level, reflected power, or data error rate). Verify operation of communications system inputs and outputs that are essential to proper functioning of the Protection System.
Any communications system with all of the following: <ul style="list-style-type: none"> • Continuous monitoring or periodic automated testing for the performance of the channel using criteria pertinent to the communications technology applied (e.g. signal level, reflected power, or data error rate, and alarming for excessive performance degradation). (See Table 2) • Some or all binary or status inputs and control outputs are monitored by a process that continuously demonstrates ability to perform as designed, with alarming for failure (See Table 2). 	12 Calendar Years	Verify only the unmonitored communications system inputs and outputs that are essential to proper functioning of the Protection System

Table 1-3 Component Type - Voltage and Current Sensing Devices Providing Inputs to Protective Relays Excluding distributed UFLS and distributed UVLS (see Table 3)		
Component Attributes	Maximum Maintenance Interval	Maintenance Activities
Any voltage and current sensing devices not having monitoring attributes of the category below.	12 Calendar Years	Verify that current and voltage signal values are provided to the protective relays.
Voltage and Current Sensing devices connected to microprocessor relays with AC measurements are continuously verified by comparison of sensing input value, as measured by the microprocessor relay, to an independent ac measurement source, with alarming for unacceptable error or failure (see Table 2).	No periodic maintenance specified	None.

Table 1-4(a) Component Type – Protection System Station dc Supply Using Vented Lead-Acid (VLA) Batteries Excluding distributed UFLS and distributed UVLS (see Table 3)		
Protection System Station dc supply used only for non-BES interrupting devices for RAS, non-distributed UFLS systems, or non-distributed UVLS systems is excluded (see Table 1-4(e)).		
Component Attributes	Maximum Maintenance Interval	Maintenance Activities
Protection System Station dc supply using Vented Lead-Acid (VLA) batteries not having monitoring attributes of Table 1-4(f).	4 Calendar Months	Verify: <ul style="list-style-type: none"> • Station dc supply voltage Inspect: <ul style="list-style-type: none"> • Electrolyte level • For unintentional grounds
	18 Calendar Months	Verify: <ul style="list-style-type: none"> • Float voltage of battery charger • Battery continuity • Battery terminal connection resistance • Battery intercell or unit-to-unit connection resistance Inspect: <ul style="list-style-type: none"> • Cell condition of all individual battery cells where cells are visible – or measure battery cell/unit internal ohmic values where the cells are not visible • Physical condition of battery rack

Table 1-4(a) Component Type – Protection System Station dc Supply Using Vented Lead-Acid (VLA) Batteries Excluding distributed UFLS and distributed UVLS (see Table 3)		
Protection System Station dc supply used only for non-BES interrupting devices for RAS, non-distributed UFLS systems, or non-distributed UVLS systems is excluded (see Table 1-4(e)).		
Component Attributes	Maximum Maintenance Interval	Maintenance Activities
	18 Calendar Months -or- 6 Calendar Years	Verify that the station battery can perform as manufactured by evaluating cell/unit measurements indicative of battery performance (e.g. internal ohmic values or float current) against the station battery baseline. -or- Verify that the station battery can perform as manufactured by conducting a performance or modified performance capacity test of the entire battery bank.

Table 1-4(b) Component Type – Protection System Station dc Supply Using Valve-Regulated Lead-Acid (VRLA) Batteries Excluding distributed UFLS and distributed UVLS (see Table 3)		
Protection System Station dc supply used only for non-BES interrupting devices for RAS, non-distributed UFLS systems, or non-distributed UVLS systems is excluded (see Table 1-4(e)).		
Component Attributes	Maximum Maintenance Interval	Maintenance Activities
Protection System Station dc supply with Valve Regulated Lead-Acid (VRLA) batteries not having monitoring attributes of Table 1-4(f).	4 Calendar Months	Verify: <ul style="list-style-type: none"> • Station dc supply voltage Inspect: <ul style="list-style-type: none"> • For unintentional grounds
	6 Calendar Months	Inspect: <ul style="list-style-type: none"> • Condition of all individual units by measuring battery cell/unit internal ohmic values.
	18 Calendar Months	Verify: <ul style="list-style-type: none"> • Float voltage of battery charger • Battery continuity • Battery terminal connection resistance • Battery intercell or unit-to-unit connection resistance Inspect: <ul style="list-style-type: none"> • Physical condition of battery rack

<p align="center">Table 1-4(b)</p> <p align="center">Component Type – Protection System Station dc Supply Using Valve-Regulated Lead-Acid (VRLA) Batteries</p> <p align="center">Excluding distributed UFLS and distributed UVLS (see Table 3)</p> <p align="center">Protection System Station dc supply used only for non-BES interrupting devices for RAS, non-distributed UFLS systems, or non-distributed UVLS systems is excluded (see Table 1-4(e)).</p>		
Component Attributes	Maximum Maintenance Interval	Maintenance Activities
	6 Calendar Months -or- 3 Calendar Years	Verify that the station battery can perform as manufactured by evaluating cell/unit measurements indicative of battery performance (e.g. internal ohmic values or float current) against the station battery baseline. -or- Verify that the station battery can perform as manufactured by conducting a performance or modified performance capacity test of the entire battery bank.

Table 1-4(c) Component Type – Protection System Station dc Supply Using Nickel-Cadmium (NiCad) Batteries Excluding distributed UFLS and distributed UVLS (see Table 3)		
Protection System Station dc supply used only for non-BES interrupting devices for RAS, non-distributed UFLS system, or non-distributed UVLS systems is excluded (see Table 1-4(e)).		
Component Attributes	Maximum Maintenance Interval	Maintenance Activities
Protection System Station dc supply Nickel-Cadmium (NiCad) batteries not having monitoring attributes of Table 1-4(f).	4 Calendar Months	Verify: <ul style="list-style-type: none"> • Station dc supply voltage Inspect: <ul style="list-style-type: none"> • Electrolyte level • For unintentional grounds
	18 Calendar Months	Verify: <ul style="list-style-type: none"> • Float voltage of battery charger • Battery continuity • Battery terminal connection resistance • Battery intercell or unit-to-unit connection resistance Inspect: <ul style="list-style-type: none"> • Cell condition of all individual battery cells. • Physical condition of battery rack

Table 1-4(c) Component Type – Protection System Station dc Supply Using Nickel-Cadmium (NiCad) Batteries Excluding distributed UFLS and distributed UVLS (see Table 3)		
Protection System Station dc supply used only for non-BES interrupting devices for RAS, non-distributed UFLS system, or non-distributed UVLS systems is excluded (see Table 1-4(e)).		
Component Attributes	Maximum Maintenance Interval	Maintenance Activities
	6 Calendar Years	Verify that the station battery can perform as manufactured by conducting a performance or modified performance capacity test of the entire battery bank.

Table 1-4(d) Component Type – Protection System Station dc Supply Using Non Battery Based Energy Storage Excluding distributed UFLS and distributed UVLS (see Table 3)		
Protection System Station dc supply used only for non-BES interrupting devices for RAS, non-distributed UFLS system, or non-distributed UVLS systems is excluded (see Table 1-4(e)).		
Component Attributes	Maximum Maintenance Interval	Maintenance Activities
Any Protection System station dc supply not using a battery and not having monitoring attributes of Table 1-4(f).	4 Calendar Months	Verify: <ul style="list-style-type: none"> • Station dc supply voltage Inspect: <ul style="list-style-type: none"> • For unintentional grounds
	18 Calendar Months	Inspect: Condition of non-battery based dc supply
	6 Calendar Years	Verify that the dc supply can perform as manufactured when ac power is not present.

Table 1-4(e) Component Type – Protection System Station dc Supply for non-BES Interrupting Devices for RAS, non-distributed UFLS, and non-distributed UVLS systems		
Component Attributes	Maximum Maintenance Interval	Maintenance Activities
Any Protection System dc supply used for tripping only non-BES interrupting devices as part of a RAS, non-distributed UFLS, or non-distributed UVLS system and not having monitoring attributes of Table 1-4(f).	When control circuits are verified (See Table 1-5)	Verify Station dc supply voltage.

Table 1-4(f) Exclusions for Protection System Station dc Supply Monitoring Devices and Systems		
Component Attributes	Maximum Maintenance Interval	Maintenance Activities
Any station dc supply with high and low voltage monitoring and alarming of the battery charger voltage to detect charger overvoltage and charger failure (See Table 2).	No periodic maintenance specified	No periodic verification of station dc supply voltage is required.
Any battery based station dc supply with electrolyte level monitoring and alarming in every cell (See Table 2).		No periodic inspection of the electrolyte level for each cell is required.
Any station dc supply with unintentional dc ground monitoring and alarming (See Table 2).		No periodic inspection of unintentional dc grounds is required.
Any station dc supply with charger float voltage monitoring and alarming to ensure correct float voltage is being applied on the station dc supply (See Table 2).		No periodic verification of float voltage of battery charger is required.
Any battery based station dc supply with monitoring and alarming of battery string continuity (See Table 2).		No periodic verification of the battery continuity is required.
Any battery based station dc supply with monitoring and alarming of the intercell and/or terminal connection detail resistance of the entire battery (See Table 2).		No periodic verification of the intercell and terminal connection resistance is required.
Any Valve Regulated Lead-Acid (VRLA) or Vented Lead-Acid (VLA) station battery with internal ohmic value or float current monitoring and alarming, and evaluating present values relative to baseline internal ohmic values for every cell/unit (See Table 2).		No periodic evaluation relative to baseline of battery cell/unit measurements indicative of battery performance is required to verify the station battery can perform as manufactured.
Any Valve Regulated Lead-Acid (VRLA) or Vented Lead-Acid (VLA) station battery with monitoring and alarming of each cell/unit internal ohmic value (See Table 2).		No periodic inspection of the condition of all individual units by measuring battery cell/unit internal ohmic values of a station VRLA or Vented Lead-Acid (VLA) battery is required.

Table 1-5 Component Type - Control Circuitry Associated With Protective Functions Excluding distributed UFLS and distributed UVLS (see Table 3), Automatic Reclosing (see Table 4), and Sudden Pressure Relaying (see Table 5) Note: Table requirements apply to all Control Circuitry Components of Protection Systems, and RAS except as noted.		
Component Attributes	Maximum Maintenance Interval	Maintenance Activities
Trip coils or actuators of circuit breakers, interrupting devices, or mitigating devices (regardless of any monitoring of the control circuitry).	6 Calendar Years	Verify that each trip coil is able to operate the circuit breaker, interrupting device, or mitigating device.
Electromechanical lockout devices which are directly in a trip path from the protective relay to the interrupting device trip coil (regardless of any monitoring of the control circuitry).	6 Calendar Years	Verify electrical operation of electromechanical lockout devices.
Unmonitored control circuitry associated with RAS. (See Table 4-2(b) for RAS which include Automatic Reclosing.)	12 Calendar Years	Verify all paths of the control circuits essential for proper operation of the RAS.
Unmonitored control circuitry associated with protective functions inclusive of all auxiliary relays.	12 Calendar Years	Verify all paths of the trip circuits inclusive of all auxiliary relays through the trip coil(s) of the circuit breakers or other interrupting devices.
Control circuitry associated with protective functions and/or RAS whose integrity is monitored and alarmed (See Table 2).	No periodic maintenance specified	None.

Table 2 – Alarming Paths and Monitoring In Tables 1-1 through 1-5, Table 3, Tables 4-1 through 4-2, and Table 5 alarm attributes used to justify extended maximum maintenance intervals and/or reduced maintenance activities are subject to the following maintenance requirements		
Component Attributes	Maximum Maintenance Interval	Maintenance Activities
Any alarm path through which alarms in Tables 1-1 through 1-5, Table 3, Tables 4-1 through 4-2, and Table 5 are conveyed from the alarm origin to the location where corrective action can be initiated, and not having all the attributes of the “Alarm Path with monitoring” category below. Alarms are reported within 24 hours of detection to a location where corrective action can be initiated.	12 Calendar Years	Verify that the alarm path conveys alarm signals to a location where corrective action can be initiated.
Alarm Path with monitoring: The location where corrective action is taken receives an alarm within 24 hours for failure of any portion of the alarming path from the alarm origin to the location where corrective action can be initiated.	No periodic maintenance specified	None.

Table 3 Maintenance Activities and Intervals for distributed UFLS and distributed UVLS Systems		
Component Attributes	Maximum Maintenance Interval	Maintenance Activities
Any unmonitored protective relay not having all the monitoring attributes of a category below.	6 Calendar Years	Verify that settings are as specified. For non-microprocessor relays: <ul style="list-style-type: none"> • Test and, if necessary calibrate. For microprocessor relays: <ul style="list-style-type: none"> • Verify operation of the relay inputs and outputs that are essential to proper functioning of the Protection System. • Verify acceptable measurement of power system input values.
Monitored microprocessor protective relay with the following: <ul style="list-style-type: none"> • Internal self-diagnosis and alarming (See Table 2). • Voltage and/or current waveform sampling three or more times per power cycle, and conversion of samples to numeric values for measurement calculations by microprocessor electronics. Alarming for power supply failure (See Table 2).	12 Calendar Years	Verify: <ul style="list-style-type: none"> • Settings are as specified. • Operation of the relay inputs and outputs that are essential to proper functioning of the Protection System. • Acceptable measurement of power system input values
Monitored microprocessor protective relay with preceding row attributes and the following: <ul style="list-style-type: none"> • Ac measurements are continuously verified by comparison to an independent ac measurement source, with alarming for excessive error (See Table 2). 	12 Calendar Years	Verify only the unmonitored relay inputs and outputs that are essential to proper functioning of the Protection System.

Table 3 Maintenance Activities and Intervals for distributed UFLS and distributed UVLS Systems		
Component Attributes	Maximum Maintenance Interval	Maintenance Activities
<ul style="list-style-type: none"> Some or all binary or status inputs and control outputs are monitored by a process that continuously demonstrates ability to perform as designed, with alarming for failure (See Table 2). Alarming for change of settings (See Table 2).		
Voltage and/or current sensing devices associated with UFLS or UVLS systems.	12 Calendar Years	Verify that current and/or voltage signal values are provided to the protective relays.
Protection System dc supply for tripping non-BES interrupting devices used only for a UFLS or UVLS system.	12 Calendar Years	Verify Protection System dc supply voltage.
Control circuitry between the UFLS or UVLS relays and electromechanical lockout and/or tripping auxiliary devices (excludes non-BES interrupting device trip coils).	12 Calendar Years	Verify the path from the relay to the lockout and/or tripping auxiliary relay (including essential supervisory logic).
Electromechanical lockout and/or tripping auxiliary devices associated only with UFLS or UVLS systems (excludes non-BES interrupting device trip coils).	12 Calendar Years	Verify electrical operation of electromechanical lockout and/or tripping auxiliary devices.
Control circuitry between the electromechanical lockout and/or tripping auxiliary devices and the non-BES interrupting devices in UFLS or UVLS systems, or between UFLS or UVLS relays (with no interposing electromechanical lockout or auxiliary device) and the non-BES interrupting devices (excludes non-BES interrupting device trip coils).	No periodic maintenance specified	None.
Trip coils of non-BES interrupting devices in UFLS or UVLS systems.	No periodic maintenance specified	None.

Table 4-1 Maintenance Activities and Intervals for Automatic Reclosing Components Component Type – Reclosing Relay		
Component Attributes	Maximum Maintenance Interval	Maintenance Activities
Any unmonitored reclosing relay not having all the monitoring attributes of a category below.	6 Calendar Years	Verify that settings are as specified. For non-microprocessor relays: <ul style="list-style-type: none"> • Test and, if necessary calibrate For microprocessor relays: <ul style="list-style-type: none"> • Verify operation of the relay inputs and outputs that are essential to proper functioning of the Automatic Reclosing.
Monitored microprocessor reclosing relay with the following: <ul style="list-style-type: none"> • Internal self-diagnosis and alarming (See Table 2). • Alarming for power supply failure (See Table 2). 	12 Calendar Years	Verify: <ul style="list-style-type: none"> • Settings are as specified. • Operation of the relay inputs and outputs that are essential to proper functioning of the Automatic Reclosing.

Table 4-2(a) Maintenance Activities and Intervals for Automatic Reclosing Components Component Type – Control Circuitry Associated with Reclosing Relays that are NOT an Integral Part of an RAS		
Component Attributes	Maximum Maintenance Interval	Maintenance Activities
Unmonitored Control circuitry associated with Automatic Reclosing that is not an integral part of an RAS.	12 Calendar Years	Verify that Automatic Reclosing, upon initiation, does not issue a premature closing command to the close circuitry.
Control circuitry associated with Automatic Reclosing that is not part of an RAS and is monitored and alarmed for conditions that would result in a premature closing command. (See Table 2)	No periodic maintenance specified	None.

Table 4-2(b) Maintenance Activities and Intervals for Automatic Reclosing Components Component Type – Control Circuitry Associated with Reclosing Relays that ARE an Integral Part of an RAS		
Component Attributes	Maximum Maintenance Interval	Maintenance Activities
Close coils or actuators of circuit breakers or similar devices that are used in conjunction with Automatic Reclosing as part of an RAS (regardless of any monitoring of the control circuitry).	6 Calendar Years	Verify that each close coil or actuator is able to operate the circuit breaker or mitigating device.
Unmonitored close control circuitry associated with Automatic Reclosing used as an integral part of an RAS.	12 Calendar Years	Verify all paths of the control circuits associated with Automatic Reclosing that are essential for proper operation of the RAS.
Control circuitry associated with Automatic Reclosing that is an integral part of an RAS whose integrity is monitored and alarmed. (See Table 2)	No periodic maintenance specified	None.

<p style="text-align: center;">Table 5 Maintenance Activities and Intervals for Sudden Pressure Relaying</p> <p style="text-align: center;">Note: In cases where Components of Sudden Pressure Relaying are common to Components listed in Table 1-5, the Components only need to be tested once during a distinct maintenance interval.</p>		
Component Attributes	Maximum Maintenance Interval	Maintenance Activities
Any fault pressure relay.	6 Calendar Years	Verify the pressure or flow sensing mechanism is operable.
Electromechanical lockout devices which are directly in a trip path from the fault pressure relay to the interrupting device trip coil (regardless of any monitoring of the control circuitry).	6 Calendar Years	Verify electrical operation of electromechanical lockout devices.
Unmonitored control circuitry associated with Sudden Pressure Relaying.	12 Calendar Years	Verify all paths of the trip circuits inclusive of all auxiliary relays through the trip coil(s) of the circuit breakers or other interrupting devices.
Control circuitry associated with Sudden Pressure Relaying whose integrity is monitored and alarmed (See Table 2).	No periodic maintenance specified	None.

Rationale:

During development of this standard, text boxes were embedded within the standard to explain the rationale for various parts of the standard. Upon BOT approval, the text from the rationale text boxes was moved to this section.

Rationale for Applicability Section:

This section does not reflect the applicability changes that will be proposed by the Project 2014-01 Standards Applicability for Dispersed Generation Resources standards drafting team. The changes in this posted version and those being made by the Project 2014-01 standards drafting team do not overlap.

Additionally, to align with ongoing NERC standards development in Project 2010-05.2: Special Protection Systems, the term “Special Protection Systems” in PRC-005-4 was replaced by the term “Remedial Action Schemes.” These terms are synonymous in the NERC Glossary of Terms.

Rationale for the deletion of part of the definition of Component:

The SDT determined that it was explanatory in nature and adequately addressed in the Supplementary Reference and FAQ Document.

Rationale for R3 Part 3.1:

In the last posting, the SDT included language in the standard that was originally in the implementation plan that required completion of maintenance activities within three years for newly-identified Automatic Reclosing Components following a notification under Requirement R6, which has been removed. After further discussion, the SDT determined that a separate shorter timeframe for maintenance of newly-identified Automatic Reclosing Components created unnecessary complication within the standard. The SDT agreed that entities should be responsible for maintaining the Automatic Reclosing Components subject to the standard, whether existing, newly added or newly within scope based on a change in the largest generating unit in the BA or, if a member of a Reserve Sharing Group, the largest generating unit within the Reserve Sharing Group according to the timeframes in the maintenance tables. Therefore, 3.1 and its subparts have been removed and have not been reinserted into the implementation plan.

Rationale for R4 Part 4.1:

In the last posting, the SDT included language in the standard that was originally in the implementation plan that required completion of maintenance activities within three years for newly-identified Automatic Reclosing Components following a notification under Requirement R6, which has been removed. After further discussion, the SDT determined that a separate shorter timeframe for maintenance of newly-identified Automatic Reclosing Components created unnecessary complication within the standard. The SDT agreed that entities should be responsible for maintaining the Automatic Reclosing Components subject to the standard, whether existing, newly added or newly within scope based on a change in the largest generating unit in the BA or, if a member of a Reserve Sharing Group, the largest generating

unit within the Reserve Sharing Group according to the timeframes in the maintenance tables. Therefore, 4.1 and its subparts have been removed and have not been reinserted into the implementation plan.

PRC-005 — Attachment A

Criteria for a Performance-Based Protection System Maintenance Program

Purpose: To establish a technical basis for initial and continued use of a performance-based Protection System Maintenance Program (PSMP).

To establish the technical justification for the initial use of a performance-based PSMP:

1. Develop a list with a description of Components included in each designated Segment, with a minimum Segment population of 60 Components.
2. Maintain the Components in each Segment according to the time-based maximum allowable intervals established in Tables 1-1 through 1-5, Table 3, Tables 4-1 through 4-2, and Table 5 until results of maintenance activities for the Segment are available for a minimum of 30 individual Components of the Segment.
3. Document the maintenance program activities and results for each Segment, including maintenance dates and Countable Events for each included Component.
4. Analyze the maintenance program activities and results for each Segment to determine the overall performance of the Segment and develop maintenance intervals.
5. Determine the maximum allowable maintenance interval for each Segment such that the Segment experiences Countable Events on no more than 4% of the Components within the Segment, for the greater of either the last 30 Components maintained or all Components maintained in the previous year.

To maintain the technical justification for the ongoing use of a performance-based PSMP:

1. At least annually, update the list of Components and Segments and/or description if any changes occur within the Segment.
2. Perform maintenance on the greater of 5% of the Components (addressed in the performance based PSMP) in each Segment or 3 individual Components within the Segment in each year.
3. For the prior year, analyze the maintenance program activities and results for each Segment to determine the overall performance of the Segment.
4. Using the prior year's data, determine the maximum allowable maintenance interval for each Segment such that the Segment experiences Countable Events on no more than 4% of the Components within the Segment, for the greater of either the last 30 Components maintained or all Components maintained in the previous year.

If the Components in a Segment maintained through a performance-based PSMP experience 4% or more Countable Events, develop, document, and implement an action plan to reduce the Countable Events to less than 4% of the Segment population within 3 years.

Implementation Plan

Project 2014-01 Standards Applicability for Dispersed Generation

Resources

PRC-005-5

Standards Involved

Approval:

- PRC-005-5 – Protection System and Automatic Reclosing Maintenance

Retirement:

- PRC-005-4 – Protection System and Automatic Reclosing Maintenance

Prerequisite Approvals

N/A

Background

In light of the revised “Bulk Electric System” (BES) definition adopted by the NERC Board of Trustees (Board), changes to the applicability sections of certain Reliability Standards, including PRC-005, are necessary to align them with the implementation of the revised BES definition. The Dispersed Generation Resources Standard Drafting Team (DGR SDT) for Project 2014-01 – Standards Applicability for Dispersed Generation Resources, has modified the applicability section of certain Generator Owner/Generator Operator requirements to recognize the unique technical and reliability aspects of dispersed power producing resources in order to ensure the applicability of the standards are consistent with the reliable operation of the BES.

General Considerations

Reliability Standard PRC-005-4, with its associated Implementation Plan, was adopted by the Board on November 7, 2013. The DGR SDT has revised the applicability section of PRC-005-4 to align the standard with the revised definition of the BES in the event that this version of PRC-005 is mandatory and enforceable on the effective date of the revised definition of the BES.

Effective Date

PRC-005-5 shall become effective on the later of the effective date of PRC-005-4, or the date that PRC-005-5 is approved by an applicable governmental authority or as otherwise provided for in a jurisdiction where approval by an applicable governmental authority is required for a standard to go into effect. Where approval by an applicable governmental authority is not required, the standard shall become effective either on the first day of the first calendar quarter after the date the standard is adopted by

the Board or as otherwise provided for in that jurisdiction, or 12 months following the effective date of PRC-005-4, whichever is later.

Retirement of Existing Standards

PRC-005-4 shall be retired at midnight of the day immediately prior to the effective date of PRC-005-5 in the particular jurisdiction in which the revised standard is becoming effective.

Implementation Plan

PRC-005-5 only modifies the applicability for PRC-005-4. All aspects of the Implementation Plan for PRC-005-4 will remain applicable to PRC-005-5 and are incorporated here by reference.

Cross References

The Implementation Plan for the revised definition of “Bulk Electric System” is available [here](#).

The Implementation Plan for PRC-005-4 is available [here](#).

Unofficial Comment Form

Project 2014-01 Standards Applicability for Dispersed Generation Resources

Please **DO NOT** use this form for submitting comments. Please use the [electronic form](#) to submit comments on the Standards. The electronic comment form must be completed by **January 22, 2015**.

If you have questions, please contact [Laura Anderson](#) or by telephone at 404-446-9671.

All documents for this project are available on the [project page](#).

Background Information

This posting solicits formal comments on PRC-005, a Project 2014-01 Standards Applicability for Dispersed Generation Resources (DGR) high-priority Reliability Standard, as identified in the draft White Paper prepared by the Project 2014-01 (Project) standards drafting team (DGR SDT).

The goal of the Project is to ensure that Generator Owners (GOs) and Generator Operators (GOPs) of dispersed power producing resources¹ are appropriately assigned responsibility for requirements that impact the reliability of the Bulk Power System, as the characteristics of operating dispersed power producing resources can be unique. In light of the revised Bulk Electric System (BES) definition approved by the Federal Energy Regulatory Commission in 2014, the intent of this Project is generally to maintain the status quo for applicability of the standards as they have been applied over time with respect to dispersed power producing resources where the status quo does not create a reliability gap.

The DGR SDT reviewed all standards that apply to GOs and GOPs and categorized how each standard should be applied to dispersed power producing resources to accomplish the reliability purpose of the standard. The DGR SDT developed the White Paper to explain its approach, which was posted on April 17, 2014 for an informal comment period.² Industry feedback on the White Paper allowed the DGR SDT to refine its approach and finalize recommended revisions to the standards. As part of this review, the DGR SDT identified three high-priority standards which required immediate attention:

- PRC-004;
- PRC-005; and
- VAR-002.

Because each of the high-priority standards were revised in other concurrent projects focusing on substantive revisions to the standard requirements, the DGR SDT developed revisions to allow for

¹ The terms dispersed generation resources and dispersed power producing resources are used interchangeably.

² The current version of the White Paper can be downloaded on the Project web page at <http://www.nerc.com/pa/Stand/Pages/Project-2014-01-Standards-Applicability-for-Dispersed-Generation-Resources.aspx>.

different possibilities in the timing of regulatory approvals. Now that the substantive revisions to the high-priority standards are complete, and in light of the recent NERC Board of Trustees approval of all high-priority DGR standards to date, the DGR SDT proposes these final changes to PRC-005. The intent of balloting the recommended applicability revisions separately from the technical changes made in other projects is to provide flexibility to allow approved applicability revisions to move forward on an expedited timeline as needed to support implementation of the revised definition of the BES.

Summary of Proposed Changes

The DGR SDT's recommended changes are limited to revising the applicability of the relevant version of PRC-005 to appropriately account for certain dispersed power producing resources.

The DGR SDT has posted the following standard, along with its corresponding Implementation Plan:

- PRC-005-5
- SAR

Please note that the DGR SDT has not revised the Violation Risk Factors (VRFs) or Violation Severity Levels (VSLs) associated with the high-priority standards because the proposed revisions do not change the reliability intent or impact any of the requirements. If the applicability recommendations are approved by industry as proposed, the DGR SDT would not seek to change the VRFs and VSLs.

You do not have to answer all questions. Enter comments in simple text format. Bullets, numbers, and special formatting will not be retained.

Questions

1. Do you agree with the revisions proposed in PRC-005-5 to clarify applicability of PRC-005-4 to dispersed power producing resources included in the BES through Inclusion I4 of the BES definition? If not, please provide technical rationale for your disagreement, along with suggested language changes.

Yes:

No:

Comments:

2. Do you have any additional comments to assist the DGR SDT in further developing its recommendations?

Yes:

No:

Comments:

Standards Authorization Request Form

When completed, please email this form to:
sarcomm@nerc.com

NERC welcomes suggestions to improve the reliability of the bulk power system through improved reliability standards. Please use this form to submit your request to propose a new or a revision to a NERC's Reliability Standard.

Request to propose a new or a revision to a Reliability Standard

Title of Proposed Standard:	Application of certain GO/GOP Reliability Standards and Requirements to Dispersed Generation		
Date Submitted:	10/1/2013		
SAR Requester Information			
Name:	Jennifer Sterling-Exelon, Gary Kruempel-MidAmerican, Allen Schriver-NextEra Energy, Inc., Brian Evans-Mongeon-Utility Services Inc.		
Organization:	Exelon, MidAmerican, NextEra Energy, Utility Services Inc.		
Telephone:	(630) 437-2764 – primary contact	E-mail:	jennifer.sterling@exeloncorp.com primary contact
SAR Type (Check as many as applicable)			
<input type="checkbox"/> New Standard	<input type="checkbox"/> Withdrawal of existing Standard		
<input checked="" type="checkbox"/> Revision to existing Standard	<input type="checkbox"/> Urgent Action		

SAR Information

Industry Need (What is the industry problem this request is trying to solve?):

The industry is requesting that the application section of certain GO/GOP Reliability Standards or the requirements of certain GO/GOP Reliability Standards be revised in order to ensure that the Reliability Standards are not imposing requirements on dispersed generation that are unnecessary and/or counterproductive to the reliable operation of the Bulk Electric System (BES). For purposes of this SAR, dispersed generation are those resources that aggregate to a total capacity greater than 75 MVA (gross

SAR Information

nameplate rating), and that are connected through a system designed primarily for delivering such capacity to a common point of connection at a voltage of 100 kV or above.

This request is related to the proposed new definition of the Bulk Electric System (BES) from Project 2010-17, that results in the identification of elements of new dispersed generation facilities that if included under certain Reliability Standards may result in a detriment to reliability or be technically unsound and not useful to the support of the reliable operation of the BES .

Purpose or Goal (How does this request propose to address the problem described above?):

The goal of the request is to revise the applicability of GO/GOP Reliability Standards or the Requirement(s) of GO/GOP Reliability Standards to recognize the unique technical and reliability aspects of dispersed generation, given the proposed new definition of the BES.

Identify the Objectives of the proposed standard’s requirements (What specific reliability deliverables are required to achieve the goal?):

The objective of the revisions to the applicability section and/or Requirements of certain GO/GOP Reliability Standards is to ensure that these revisions are approved by the Board of Trustees and applicable regulatory agencies prior to the effective date for newly identified elements under the proposed BES definition (i.e., June 2016).

Brief Description (Provide a paragraph that describes the scope of this standard action.)

The scope of this SAR involves revisions to the applicability section of the following GO/GOP Reliability Standard applicability sections and/or Reliability Standard Requirements: (a) PRC-005-2 (-3); (b) FAC-008-3; (c) PRC-023-3/PRC-025-1; (d) PRC-004-2a (-3) ; and (e) VAR-002-2 so it is clear what, if any, requirements should apply to dispersed generation. Also, IRO,MOD, PRC or TOP Standards that require outage and protection and control coordination, planning, next day study or real time data or reporting of changes in real and reactive capability should be examined and revised, as needed, to ensure it is clear that these activities and reporting are conducted at the point of aggregation to 75 MVA, and not at an individual turbine, inverter or unit level for dispersed generation. This scope would also include development of a technical guidance paper for standard drafting teams developing new or revised Standards, so that they do not incorrectly apply requirements to dispersed generation unless such an application is technically sound and promotes the reliable operation of the BES.

To the extent, there are existing Reliability Standard Drafting Teams that have the expertise and can make the requested changes prior to the compliance date of newly identified assets under the BES definition (i.e., June 2016), those projects may be assigned the required changes as opposed to creating new projects.

SAR Information

Detailed Description (Provide a description of the proposed project with sufficient details for the standard drafting team to execute the SAR. Also provide a justification for the development or revision of the standard, including an assessment of the reliability and market interface impacts of implementing or not implementing the standard action.)

The following description and technical justification(including an assessment of reliability impacts) is provided for the standard drafting teams to execute the SAR for each applicable Standard.

PRC-005-2

Testing and maintenance of protection and control equipment for dispersed generation should start at the point of aggregation to 75 MVA. Manufacturers of dispersed generation turbines and solar panels recommend against specific testing and maintenance regimes for protection and control equipment at the dispersed generation turbine and panel level. In fact it is counterproductive to implement protection and control at the individual turbine, solar panel, or unit level. Instead this is best done at an aggregated level. Therefore, PRC-005 should indicate that the standard applies at the point of aggregation to at 75 MVA or greater for dispersed generation. This change would clarify that the facility section 4.2.5.3 is the section that would apply to dispersed generating facilities and that the remaining sections would not apply.

FAC-008-3

For dispersed generation, it is unclear if in FAC-008-3 the term “main step up transformer” refers to the padmount transformer at the base of the windmill tower or to the main aggregating transformer that steps up voltage to transmission system voltage. From a technical standpoint, it should be the point of aggregation at 75 MVA or above that is subject to this standard for dispersed generation, such as wind. It is at the point of aggregation at 75 MVA or above that facilities ratings should start, since it is this injection point at which a planner or operator of the system is relying on the amount of megawatts the dispersed generation is providing with consideration of the most limiting element. To require facility ratings at for each dispersed turbine, panel or generating unit is not useful to a planner or operator of the system, and, therefore, FAC-008-3 should be revised to be clear that facility ratings start at the point of aggregation at 75 MVA or above for dispersed generation.

SAR Information

Also consider that the BES definition specifically excludes collector system equipment at less than 75 MVA from being included in the BES. Thus, those portions of the collector systems that handle less than 75 MVA are not BES "Facilities," and, therefore, need not be evaluated per R1 or R2. Given this, there seems to be no technical value to conduct facility ratings for individual dispersed generation turbines, generating units and panels.

PRC-023-3/PRC-025-1

In keeping with the registration criteria for Generator Owners as well as the proposed BES Definition, the 75MVA point of aggregation should be the starting point for application of relay loadability requirements.

PRC-004-2

There is no technical basis to claim that misoperation analysis, corrective action plan implementation and reporting for dispersed generation at the turbine, generating unit or panel level is needed for the reliable operation of the BES. Similar to the statements above, the appropriate point to require misoperation analysis, corrective action plan implementation and reporting is at the point of aggregation at 75 MVA and above.

VAR-002-2

Voltage control for some types of dispersed generating facilities is accomplished by a controller that is able to adjust either generating unit controls or discrete reactive components to provide transmission system voltage adjustment. The VAR-002 standard should be modified to allow this type of control for dispersed generation facilities under the requirements of the standard.

General review of IROs, MODs, PRCs, TOPs

IRO, MOD, PRC or TOP Standards that require outage and protection and control coordination, planning, next day study or real time data or reporting of changes in real and reactive capability should be examined and revised, as needed, to ensure it is clear that these activities are conducted at the point of aggregation at 75 MVA, and not an individual turbine, generating unit or panel level for dispersed generation. Unless this clarity is provided applicability at a finer level of granularity related to dispersed generation may be seen as required and such granularity will result in activities that have no benefit to

Standards Authorization Request Form

SAR Information

reliable operation of the BES. Furthermore applicability at a finer level of granularity will result in unneeded and ineffective collection, analysis, and reporting activities that may result in a detriment to reliability.

Reliability Functions

The Standard will Apply to the Following Functions (Check each one that applies.)

<input type="checkbox"/> Reliability Coordinator	Responsible for the real-time operating reliability of its Reliability Coordinator Area in coordination with its neighboring Reliability Coordinator’s wide area view.
<input type="checkbox"/> Balancing Authority	Integrates resource plans ahead of time, and maintains load-interchange-resource balance within a Balancing Authority Area and supports Interconnection frequency in real time.
<input type="checkbox"/> Interchange Authority	Ensures communication of interchange transactions for reliability evaluation purposes and coordinates implementation of valid and balanced interchange schedules between Balancing Authority Areas.
<input type="checkbox"/> Planning Coordinator	Assesses the longer-term reliability of its Planning Coordinator Area.
<input type="checkbox"/> Resource Planner	Develops a >one year plan for the resource adequacy of its specific loads within a Planning Coordinator area.
<input type="checkbox"/> Transmission Planner	Develops a >one year plan for the reliability of the interconnected Bulk Electric System within its portion of the Planning Coordinator area.
<input type="checkbox"/> Transmission Service Provider	Administers the transmission tariff and provides transmission services under applicable transmission service agreements (e.g., the pro forma tariff).
<input type="checkbox"/> Transmission Owner	Owns and maintains transmission facilities.
<input type="checkbox"/> Transmission Operator	Ensures the real-time operating reliability of the transmission assets within a Transmission Operator Area.

Standards Authorization Request Form

Reliability Functions	
<input type="checkbox"/> Distribution Provider	Delivers electrical energy to the End-use customer.
<input checked="" type="checkbox"/> Generator Owner	Owns and maintains generation facilities.
<input checked="" type="checkbox"/> Generator Operator	Operates generation unit(s) to provide real and reactive power.
<input type="checkbox"/> Purchasing-Selling Entity	Purchases or sells energy, capacity, and necessary reliability-related services as required.
<input type="checkbox"/> Market Operator	Interface point for reliability functions with commercial functions.
<input type="checkbox"/> Load-Serving Entity	Secures energy and transmission service (and reliability-related services) to serve the End-use Customer.

Reliability and Market Interface Principles	
Applicable Reliability Principles (Check all that apply).	
<input checked="" type="checkbox"/>	1. Interconnected bulk power systems shall be planned and operated in a coordinated manner to perform reliably under normal and abnormal conditions as defined in the NERC Standards.
<input type="checkbox"/>	2. The frequency and voltage of interconnected bulk power systems shall be controlled within defined limits through the balancing of real and reactive power supply and demand.
<input checked="" type="checkbox"/>	3. Information necessary for the planning and operation of interconnected bulk power systems shall be made available to those entities responsible for planning and operating the systems reliably.
<input type="checkbox"/>	4. Plans for emergency operation and system restoration of interconnected bulk power systems shall be developed, coordinated, maintained and implemented.
<input checked="" type="checkbox"/>	5. Facilities for communication, monitoring and control shall be provided, used and maintained for the reliability of interconnected bulk power systems.
<input type="checkbox"/>	6. Personnel responsible for planning and operating interconnected bulk power systems shall be trained, qualified, and have the responsibility and authority to implement actions.
<input type="checkbox"/>	7. The security of the interconnected bulk power systems shall be assessed, monitored and maintained on a wide area basis.
<input type="checkbox"/>	8. Bulk power systems shall be protected from malicious physical or cyber attacks.
Does the proposed Standard comply with all of the following Market Interface Principles?	
Enter (yes/no)	
1. A reliability standard shall not give any market participant an unfair competitive advantage.	Yes

Standards Authorization Request Form

Reliability and Market Interface Principles	
2. A reliability standard shall neither mandate nor prohibit any specific market structure.	Yes
3. A reliability standard shall not preclude market solutions to achieving compliance with that standard.	Yes
4. A reliability standard shall not require the public disclosure of commercially sensitive information. All market participants shall have equal opportunity to access commercially non-sensitive information that is required for compliance with reliability standards.	Yes

Related Standards	
Standard No.	Explanation
PRC-005-2, FAC-008-3, PRC-023-3/PRC-025-1/PRC-004-2a, VAR-002-2b and various IRO, MOD, PRC and TOP Standards	See explanation under technical analysis.

Related SARs	
SAR ID	Explanation
	N/A

Standards Authorization Request Form

Related SARs	

Regional Variances	
Region	Explanation
ERCOT	
FRCC	
MRO	
NPCC	
RFC	
SERC	
SPP	
WECC	

Standards Announcement

Project 2014-01 Standards Applicability for Dispersed Generation Resources

Formal Comment Period Now Open through January 22, 2015
Ballot Pool Forming Now through January 7, 2015

[Now Available](#)

A 45-day posting to solicit formal comments on **PRC-005-5- Protection System, Automatic Reclosing, and Sudden Pressure Relaying Maintenance** is open through **8 p.m. Eastern on Thursday, January 22, 2015**.

If you have questions please contact [Laura Anderson](#) (via email) or by telephone at 404-446-9671.

Background information for this project can be found on the [project page](#).

Instructions for Commenting

Please use the [electronic form](#) to submit comments on the standard and implementation plan. If you experience any difficulties in using the electronic form, please contact [Arielle Cunningham](#). An off-line, unofficial copy of the comment form is posted on the [project page](#).

Instructions for Joining Ballot Pools

A ballot pool is currently being formed. Registered Ballot Body members must join the ballot pool to be eligible to cast a ballot. Registered Ballot Body members may join the ballot pool at the following page: [Join Ballot Pool](#)

NOTE: If you had previously joined a ballot pool for PRC-005, you still must rejoin this ballot pool to cast a vote, as previous PRC-005 ballot pool members are not carried over to this ballot pool.

During the pre-ballot window, members of the ballot pool may communicate with one another by using their "ballot pool listserv." (Once the balloting begins, ballot pool members are prohibited from using the ballot pool listserv) The listserv for this project is:

bp-2014-01-PRC-005-5_in@nerc.com

Next Steps

A ballot period for the standard will be conducted **January 12-22, 2015**.

For information on the **Standards Development Process**, please refer to the [Standard Processes Manual](#).

*For more information or assistance, please contact [Laura Anderson](#),
Standards Developer, or at 404-446-9671.*

North American Electric Reliability Corporation
3353 Peachtree Rd, NE
Suite 600, North Tower
Atlanta, GA 30326
404-446-2560 | www.nerc.com

Standards Announcement

Project 2014-01 Standards Applicability for Dispersed Generation Resources

Formal Comment Period Now Open through January 22, 2015
Ballot Pool Forming Now through January 7, 2015

[Now Available](#)

A 45-day posting to solicit formal comments on **PRC-005-5- Protection System, Automatic Reclosing, and Sudden Pressure Relaying Maintenance** is open through **8 p.m. Eastern on Thursday, January 22, 2015**.

If you have questions please contact [Laura Anderson](#) (via email) or by telephone at 404-446-9671.

Background information for this project can be found on the [project page](#).

Instructions for Commenting

Please use the [electronic form](#) to submit comments on the standard and implementation plan. If you experience any difficulties in using the electronic form, please contact [Arielle Cunningham](#). An off-line, unofficial copy of the comment form is posted on the [project page](#).

Instructions for Joining Ballot Pools

A ballot pool is currently being formed. Registered Ballot Body members must join the ballot pool to be eligible to cast a ballot. Registered Ballot Body members may join the ballot pool at the following page: [Join Ballot Pool](#)

NOTE: If you had previously joined a ballot pool for PRC-005, you still must rejoin this ballot pool to cast a vote, as previous PRC-005 ballot pool members are not carried over to this ballot pool.

During the pre-ballot window, members of the ballot pool may communicate with one another by using their "ballot pool listserv." (Once the balloting begins, ballot pool members are prohibited from using the ballot pool listserv) The listserv for this project is:

bp-2014-01-PRC-005-5_in@nerc.com

Next Steps

A ballot period for the standard will be conducted **January 12-22, 2015**.

For information on the **Standards Development Process**, please refer to the [Standard Processes Manual](#).

*For more information or assistance, please contact [Laura Anderson](#),
Standards Developer, or at 404-446-9671.*

North American Electric Reliability Corporation
3353 Peachtree Rd, NE
Suite 600, North Tower
Atlanta, GA 30326
404-446-2560 | www.nerc.com

Standards Announcement

Project 2014-01 Standards Applicability for Dispersed Generation Resources

Formal Comment Period Now Open through January 22, 2015
Ballot Pool Forming Now through January 7, 2015

[Now Available](#)

A 45-day posting to solicit formal comments on **PRC-005-5- Protection System, Automatic Reclosing, and Sudden Pressure Relaying Maintenance** is open through **8 p.m. Eastern on Thursday, January 22, 2015**.

If you have questions please contact [Laura Anderson](#) (via email) or by telephone at 404-446-9671.

Background information for this project can be found on the [project page](#).

Instructions for Commenting

Please use the [electronic form](#) to submit comments on the standard and implementation plan. If you experience any difficulties in using the electronic form, please contact [Arielle Cunningham](#). An off-line, unofficial copy of the comment form is posted on the [project page](#).

Instructions for Joining Ballot Pools

A ballot pool is currently being formed. Registered Ballot Body members must join the ballot pool to be eligible to cast a ballot. Registered Ballot Body members may join the ballot pool at the following page: [Join Ballot Pool](#)

NOTE: If you had previously joined a ballot pool for PRC-005, you still must rejoin this ballot pool to cast a vote, as previous PRC-005 ballot pool members are not carried over to this ballot pool.

During the pre-ballot window, members of the ballot pool may communicate with one another by using their "ballot pool listserv." (Once the balloting begins, ballot pool members are prohibited from using the ballot pool listserv) The listserv for this project is:

bp-2014-01-PRC-005-5_in@nerc.com

Next Steps

A ballot period for the standard will be conducted **January 12-22, 2015**.

For information on the **Standards Development Process**, please refer to the [Standard Processes Manual](#).

*For more information or assistance, please contact [Laura Anderson](#),
Standards Developer, or at 404-446-9671.*

North American Electric Reliability Corporation
3353 Peachtree Rd, NE
Suite 600, North Tower
Atlanta, GA 30326
404-446-2560 | www.nerc.com

Standards Announcement

Project 2014-01 Standards Applicability for Dispersed Generation Resources PRC-005-5

Initial Ballot Results

[Now Available](#)

An initial ballot for one Project 2014-01 Dispersed Generation Resources Reliability Standard - **PRC-005-5 - Protection System, Automatic Reclosing, and Sudden Pressure Relaying Maintenance** concluded at **8 p.m. Eastern, Thursday, January 22, 2015.**

The standard achieved quorum and received sufficient affirmative votes for approval. Voting statistics are listed below, and the [Ballot Results](#) page provides a link to the detailed results for the ballot.

Quorum /Approval
77.93% / 93.74%

Background information for this project can be found on the [project page](#).

Next Steps

The drafting team will consider all comments received during the formal comment period and, if needed, make revisions to the standard and post it for an additional ballot. If the comments do not show the need for significant revisions, the standard will proceed to a final ballot.

For more information on the **Standards Development Process**, please refer to the [Standard Processes Manual](#).

*For more information or assistance, please contact [Katherine Street](#),
Standards Development Administrator, or at 404-446-9702.*

North American Electric Reliability Corporation
3353 Peachtree Rd, NE
Suite 600, North Tower
Atlanta, GA 30326
404-446-2560 | www.nerc.com

Log In

- Ballot Pools
- Current Ballots
- Ballot Results
- Registered Ballot Body
- Proxy Voters
- Register

[Home Page](#)

Ballot Results	
Ballot Name:	Project 2014-01-DGR-PRC-005-5
Ballot Period:	1/12/2015 - 1/22/2015
Ballot Type:	Initial
Total # Votes:	279
Total Ballot Pool:	358
Quorum:	77.93 % The Quorum has been reached
Weighted Segment Vote:	93.74 %
Ballot Results:	The ballot has closed

Summary of Ballot Results										
Segment	Ballot Pool	Segment Weight	Affirmative		Negative		Negative Vote without a Comment	Abstain	No Vote	
			# Votes	Fraction	# Votes	Fraction				
1 - Segment 1	93	1	61	0.938	4	0.062	0	10	18	
2 - Segment 2	6	0	0	0	0	0	0	4	2	
3 - Segment 3	79	1	49	0.925	4	0.075	0	10	16	
4 - Segment 4	29	1	22	1	0	0	0	3	4	
5 - Segment 5	83	1	48	0.906	5	0.094	0	6	24	
6 - Segment 6	52	1	33	0.943	2	0.057	0	5	12	
7 - Segment 7	2	0	0	0	0	0	0	1	1	
8 - Segment 8	3	0.3	2	0.2	1	0.1	0	0	0	
9 - Segment 9	3	0.2	2	0.2	0	0	0	0	1	

10 - Segment 10	8	0.7	7	0.7	0	0	0	0	1
Totals	358	6.2	224	5.812	16	0.388	0	39	79

Individual Ballot Pool Results				
Segment	Organization	Member	Ballot	NERC Notes
1	Ameren Services	Eric Scott	Negative	SUPPORTS THIRD PARTY COMMENTS - (Ameren)
1	American Electric Power	Paul B Johnson	Negative	SUPPORTS THIRD PARTY COMMENTS - (Tom Foltz - AEP)
1	Arizona Public Service Co.	Brian Cole	Affirmative	
1	Associated Electric Cooperative, Inc.	John Bussman	Affirmative	
1	ATCO Electric	David Downey		
1	Austin Energy	James Armke	Affirmative	
1	Balancing Authority of Northern California	Kevin Smith	Affirmative	
1	Baltimore Gas & Electric Company	Christopher J Scanlon	Affirmative	
1	Beaches Energy Services	Don Cuevas	Affirmative	
1	Black Hills Corp	Wes Wingen		
1	Bonneville Power Administration	Donald S. Watkins	Affirmative	
1	Brazos Electric Power Cooperative, Inc.	Tony Kroskey		
1	Bryan Texas Utilities	John C Fontenot	Affirmative	
1	Central Electric Power Cooperative	Michael B Bax		
1	Central Iowa Power Cooperative	Kevin J Lyons		
1	Central Maine Power Company	Joseph Turano Jr.	Affirmative	
1	City of Tallahassee	Daniel S Langston	Affirmative	
1	Clark Public Utilities	Jack Stamper	Affirmative	
1	Cleco Corporation	John Lindsey	Affirmative	
1	Colorado Springs Utilities	Shawna Speer	Affirmative	
1	Consolidated Edison Co. of New York	Christopher L de Graffenried	Affirmative	
1	CPS Energy	Glenn Pressler	Affirmative	
1	Dairyland Power Coop.	Robert W. Roddy	Affirmative	
1	Dominion Virginia Power	Larry Nash	Affirmative	
1	Duke Energy Carolina	Doug E Hills	Affirmative	
1	Entergy Transmission	Oliver A Burke	Affirmative	
1	FirstEnergy Corp.	William J Smith	Affirmative	
1	Florida Keys Electric Cooperative Assoc.	Dennis Minton	Affirmative	
1	Florida Power & Light Co.	Mike O'Neil	Affirmative	
1	Georgia Transmission Corporation	Jason Snodgrass	Affirmative	
1	Great River Energy	Gordon Pietsch	Affirmative	
1	Hydro One Networks, Inc.	Payam Farahbakhsh	Affirmative	
1	Hydro-Quebec TransEnergie	Martin Boisvert	Abstain	
1	Idaho Power Company	Craig Jones	Affirmative	
1	International Transmission Company Holdings Corp	Michael Moltane	Abstain	
1	JDRJC Associates	Jim D Cyrulewski		
1	JEA	Ted E Hobson		
1	KAMO Electric Cooperative	Walter Kenyon	Affirmative	
1	Kansas City Power & Light Co.	Daniel Gibson	Affirmative	
1	Lakeland Electric	Larry E Watt		
1	Lincoln Electric System	Doug Bantam	Affirmative	
1	Long Island Power Authority	Robert Ganley		
1	Los Angeles Department of Water & Power	faranak sarbaz		
1	Lower Colorado River Authority	Martyn Turner		
1	M & A Electric Power Cooperative	William Price	Affirmative	
1	Manitoba Hydro	Mike Smith	Affirmative	
1	MEAG Power	Danny Dees	Affirmative	
1	MidAmerican Energy Co.	Terry Harbour	Affirmative	

1	Muscatine Power & Water	Andrew J Kurriger		
1	N.W. Electric Power Cooperative, Inc.	Mark Ramsey	Affirmative	
1	National Grid USA	Michael Jones	Affirmative	
1	NB Power Corporation	Alan MacNaughton		
1	Nebraska Public Power District	Jamison Cawley	Affirmative	
1	New York Power Authority	Bruce Metruck	Affirmative	
1	Northeast Missouri Electric Power Cooperative	Kevin White	Affirmative	
1	Northeast Utilities	William Temple	Affirmative	
1	Northern Indiana Public Service Co.	Julaine Dyke	Abstain	
1	Ohio Valley Electric Corp.	Scott R Cunningham	Negative	SUPPORTS THIRD PARTY COMMENTS - (Thomas E. Foltz, American Electric Power)
1	Oklahoma Gas and Electric Co.	Terri Pyle	Affirmative	
1	Omaha Public Power District	Doug Peterchuck	Affirmative	
1	Oncor Electric Delivery	Rod Kinard	Abstain	
1	Platte River Power Authority	John C. Collins	Affirmative	
1	Portland General Electric Co.	John T Walker	Affirmative	
1	Potomac Electric Power Co.	David Thorne	Abstain	
1	PPL Electric Utilities Corp.	Brenda L Truhe	Abstain	
1	Public Service Electric and Gas Co.	Joseph A Smith	Affirmative	
1	Public Utility District No. 1 of Okanogan County	Dale Dunckel	Affirmative	
1	Puget Sound Energy, Inc.	Denise M Lietz	Abstain	
1	Rochester Gas and Electric Corp.	John C. Allen	Affirmative	
1	Sacramento Municipal Utility District	Tim Kelley	Affirmative	
1	Salt River Project	Steven C Cobb	Affirmative	
1	San Diego Gas & Electric	Will Speer		
1	SaskPower	Wayne Guttormson	Abstain	
1	Seattle City Light	Pawel Krupa	Affirmative	
1	Seminole Electric Cooperative, Inc.	Mark Churilla	Affirmative	
1	Sho-Me Power Electric Cooperative	Denise Stevens	Affirmative	
1	Snohomish County PUD No. 1	Long T Duong	Affirmative	
1	South Carolina Electric & Gas Co.	Tom Hanzlik	Affirmative	
1	South Carolina Public Service Authority	Shawn T Abrams		
1	Southern California Edison Company	Steven Mavis	Affirmative	
1	Southern Company Services, Inc.	Robert A. Schaffeld	Affirmative	
1	Southern Illinois Power Coop.	William Hutchison		
1	Southwest Transmission Cooperative, Inc.	John Shaver	Negative	SUPPORTS THIRD PARTY COMMENTS - (ACES)
1	Tacoma Power	John Merrell	Abstain	
1	Tennessee Valley Authority	Howell D Scott	Abstain	
1	Trans Bay Cable LLC	Steven Powell	Affirmative	
1	Tri-State Generation & Transmission Association, Inc.	Tracy Sliman	Affirmative	
1	Tucson Electric Power Co.	John Tolo		
1	U.S. Bureau of Reclamation	Richard T Jackson		
1	United Illuminating Co.	Jonathan Appelbaum	Affirmative	
1	Westar Energy	Kevin Giles	Affirmative	
1	Western Area Power Administration	Steven Johnson	Affirmative	
1	Xcel Energy, Inc.	Gregory L Pieper	Affirmative	
2	BC Hydro	Venkataramakrishnan Vinnakota		
2	Electric Reliability Council of Texas, Inc.	Cheryl Moseley	Abstain	
2	ISO New England, Inc.	Matthew F Goldberg		
2	MISO	Marie Knox	Abstain	
2	PJM Interconnection, L.L.C.	stephanie monzon	Abstain	
2	Southwest Power Pool, Inc.	Charles H. Yeung	Abstain	
3	AEP	Michael E Deloach	Negative	SUPPORTS THIRD PARTY COMMENTS - (Thomas

				Foltz - American Electric Power)
3	Alabama Power Company	Robert S Moore	Affirmative	
3	Ameren Corp.	David J Jendras	Negative	COMMENT RECEIVED
3	APS	Sarah Kist		
3	Associated Electric Cooperative, Inc.	Todd Bennett	Affirmative	
3	Avista Corp.	Scott J Kinney		
3	Basin Electric Power Cooperative	Jeremy Voll	Negative	COMMENT RECEIVED
3	Beaches Energy Services	Steven Lancaster	Affirmative	
3	Bonneville Power Administration	Rebecca Berdahl	Affirmative	
3	Central Electric Power Cooperative	Adam M Weber		
3	City of Austin dba Austin Energy	Andrew Gallo	Affirmative	
3	City of Bartow, Florida	Matt Culverhouse	Affirmative	
3	City of Clewiston	Lynne Mila	Affirmative	
3	City of Farmington	Linda R Jacobson	Abstain	
3	City of Green Cove Springs	Mark Schultz	Affirmative	
3	City of Leesburg	Chris Adkins	Affirmative	
3	City of Redding	Bill Hughes	Affirmative	
3	Cleco Corporation	Michelle A Corley	Affirmative	
3	Colorado Springs Utilities	Jean Mueller	Affirmative	
3	ComEd	John Bee	Affirmative	
3	Consolidated Edison Co. of New York	Peter T Yost		
3	Consumers Energy Company	Gerald G Farringer	Negative	COMMENT RECEIVED
3	Cowlitz County PUD	Russell A Noble	Affirmative	
3	Dominion Resources, Inc.	Connie B Lowe	Affirmative	
3	DTE Electric	Kent Kujala	Abstain	
3	FirstEnergy Corp.	Richard S Hoag	Affirmative	
3	Florida Keys Electric Cooperative	Tom B Anthony	Abstain	
3	Florida Municipal Power Agency	Joe McKinney	Affirmative	
3	Florida Power & Light Co.	Summer C. Esquerre		
3	Florida Power Corporation	Lee Schuster		
3	Fort Pierce Utilities Authority	Thomas Parker	Affirmative	
3	Gainesville Regional Utilities	Kenneth Simmons	Affirmative	
3	Great River Energy	Brian Glover		
3	Hydro One Networks, Inc.	Paul Malozewski	Affirmative	
3	JEA	Garry Baker		
3	KAMO Electric Cooperative	Theodore J Hilmes	Affirmative	
3	Kansas City Power & Light Co.	Joshua D Bach	Affirmative	
3	Kissimmee Utility Authority	Gregory D Woessner	Affirmative	
3	Lakeland Electric	Mace D Hunter	Affirmative	
3	Lincoln Electric System	Jason Fortik	Affirmative	
3	Los Angeles Department of Water & Power	Mike Anctil		
3	Louisville Gas and Electric Co.	Charles A. Freibert	Abstain	
3	M & A Electric Power Cooperative	Stephen D Pogue	Affirmative	
3	Manitoba Hydro	Greg C. Parent	Affirmative	
3	MEAG Power	Roger Brand	Affirmative	
3	MidAmerican Energy Co.	Thomas C. Mielnik	Affirmative	
3	Muscatine Power & Water	Seth Shoemaker		
3	N.W. Electric Power Cooperative, Inc.	John Stickley	Affirmative	
3	National Grid USA	Brian E Shanahan	Affirmative	
3	Nebraska Public Power District	Tony Eddleman	Affirmative	
3	New York Power Authority	David R Rivera	Affirmative	
3	Northeast Missouri Electric Power Cooperative	Skyler Wiegmann	Affirmative	
3	Northern Indiana Public Service Co.	Ramon J Barany	Abstain	
3	Ocala Utility Services	Randy Hahn	Affirmative	
3	Oklahoma Gas and Electric Co.	Donald Hargrove	Affirmative	
3	Orlando Utilities Commission	Ballard K Mutters	Abstain	
3	Owensboro Municipal Utilities	Thomas T Lyons	Abstain	
3	Pacific Gas and Electric Company	John H Hagen	Affirmative	
3	Platte River Power Authority	Terry L Baker		
3	PNM Resources	Michael Mertz		
3	Portland General Electric Co.	Thomas G Ward	Affirmative	
3	Potomac Electric Power Co.	Mark Yerger	Abstain	

3	Public Service Electric and Gas Co.	Jeffrey Mueller	Affirmative	
3	Puget Sound Energy, Inc.	Andrea Basinski		
3	Rutherford EMC	Thomas Haire	Affirmative	
3	Sacramento Municipal Utility District	James Leigh-Kendall	Affirmative	
3	Salt River Project	John T. Underhill	Affirmative	
3	Santee Cooper	James M Poston		
3	Seattle City Light	Dana Wheelock	Affirmative	
3	Seminole Electric Cooperative, Inc.	James R Frauen	Affirmative	
3	Snohomish County PUD No. 1	Mark Oens	Affirmative	
3	South Carolina Electric & Gas Co.	Hubert C Young	Affirmative	
3	Tacoma Power	Marc Donaldson	Abstain	
3	Tampa Electric Co.	Ronald L. Donahey		
3	Tennessee Valley Authority	Ian S Grant	Abstain	
3	Tri-State Generation & Transmission Association, Inc.	Janelle Marriott		
3	Westar Energy	Bo Jones	Affirmative	
3	Wisconsin Electric Power Marketing	James R Keller	Affirmative	
3	Xcel Energy, Inc.	Michael Ibold	Affirmative	
4	Alliant Energy Corp. Services, Inc.	Kenneth Goldsmith	Affirmative	
4	Blue Ridge Power Agency	Duane S Dahlquist	Affirmative	
4	City of Austin dba Austin Energy	Reza Ebrahimian	Affirmative	
4	City of New Smyrna Beach Utilities Commission	Tim Beyrle	Affirmative	
4	City of Redding	Nicholas Zettel	Affirmative	
4	City of Winter Park	Mark Brown	Affirmative	
4	City Utilities of Springfield, Missouri	John Allen	Affirmative	
4	Cowlitz County PUD	Rick Syring	Affirmative	
4	DTE Electric	Daniel Herring	Abstain	
4	Flathead Electric Cooperative	Russ Schneider		
4	Florida Municipal Power Agency	Carol Chinn	Affirmative	
4	Fort Pierce Utilities Authority	Javier Cisneros	Affirmative	
4	Georgia System Operations Corporation	Guy Andrews	Affirmative	
4	Herb Schrayshuen	Herb Schrayshuen	Affirmative	
4	Indiana Municipal Power Agency	Jack Alvey	Abstain	
4	Keys Energy Services	Stan T Rzad	Affirmative	
4	Madison Gas and Electric Co.	Joseph DePoorter	Affirmative	
4	Modesto Irrigation District	Spencer Tacke		
4	Ohio Edison Company	Douglas Hohlbaugh	Affirmative	
4	Oklahoma Municipal Power Authority	Ashley Stringer	Affirmative	
4	Old Dominion Electric Coop.	Mark Ringhausen	Affirmative	
4	Public Utility District No. 1 of Snohomish County	John D Martinsen	Affirmative	
4	Sacramento Municipal Utility District	Mike Ramirez	Affirmative	
4	Seattle City Light	Hao Li	Affirmative	
4	Seminole Electric Cooperative, Inc.	Steven R Wallace		
4	South Mississippi Electric Power Association	Steve McElhaney		
4	Tacoma Public Utilities	Keith Morisette	Abstain	
4	Utility Services, Inc.	Brian Evans-Mongeon	Affirmative	
4	Wisconsin Energy Corp.	Anthony P Jankowski	Affirmative	
5	Acciona Energy North America	George E Brown	Affirmative	
5	Amerenue	Sam Dwyer	Negative	SUPPORTS THIRD PARTY COMMENTS - (Ameren submitted comments)
5	American Electric Power	Thomas Foltz	Negative	COMMENT RECEIVED
5	Arizona Public Service Co.	Scott Takinen	Affirmative	
5	Associated Electric Cooperative, Inc.	Matthew Pacobit	Affirmative	
5	Avista Corp.	Steve Wenke		
5	Basin Electric Power Cooperative	Mike Kraft	Negative	SUPPORTS THIRD PARTY COMMENTS - (Jeremy Voll)
5	BC Hydro and Power Authority	Clement Ma		
5	Boise-Kuna Irrigation District/dba Lucky peak	Mike D Kukla		

	power plant project			
5	Bonneville Power Administration	Francis J. Halpin	Affirmative	
5	Brazos Electric Power Cooperative, Inc.	Shari Heino	Negative	SUPPORTS THIRD PARTY COMMENTS - (ACES)
5	Calpine Corporation	Hamid Zakery	Affirmative	
5	Choctaw Generation Limited Partnership, LLLP	Rob Watson		
5	City of Austin dba Austin Energy	Jeanie Doty	Affirmative	
5	City of Redding	Paul A. Cummings	Affirmative	
5	City of Tallahassee	Karen Webb	Affirmative	
5	Cleco Power	Stephanie Huffman	Affirmative	
5	Cogentrix Energy Power Management, LLC	Mike D Hirst		
5	Colorado Springs Utilities	Kaleb Brimhall	Affirmative	
5	Con Edison Company of New York	Brian O'Boyle	Affirmative	
5	Consumers Energy Company	David C Greyerbiehl	Negative	SUPPORTS THIRD PARTY COMMENTS - (William English)
5	Cowlitz County PUD	Bob Essex	Affirmative	
5	Dairyland Power Coop.	Tommy Drea		
5	Dominion Resources Services	Randall C Heise	Affirmative	
5	DTE Electric	Mark Stefaniak		
5	Duke Energy	Dale Q Goodwine	Affirmative	
5	E.ON Climate & Renewables North America, LLC	Karin Schweitzer		
5	Entergy Services, Inc.	Tracey Stubbs	Affirmative	
5	Exelon Nuclear	Mark F Draper	Affirmative	
5	First Wind	John Robertson	Affirmative	
5	FirstEnergy Solutions	Kenneth Dresner	Affirmative	
5	Florida Municipal Power Agency	David Schumann	Affirmative	
5	Great River Energy	Preston L Walsh		
5	Hydro-Québec Production	Roger Dufresne	Abstain	
5	Ingleside Cogeneration LP	Michelle R DAntuono	Affirmative	
5	Invenery LLC	Alan Beckham	Affirmative	
5	JEA	John J Babik		
5	Kansas City Power & Light Co.	Brett Holland	Affirmative	
5	Kissimmee Utility Authority	Mike Blough	Affirmative	
5	Lakeland Electric	James M Howard		
5	Liberty Electric Power LLC	Daniel Duff	Affirmative	
5	Lincoln Electric System	Dennis Florom	Affirmative	
5	Los Angeles Department of Water & Power	Kenneth Silver		
5	Lower Colorado River Authority	Dixie Wells	Abstain	
5	Luminant Generation Company LLC	Rick Terrill	Affirmative	
5	Manitoba Hydro	Yuguang Xiao	Affirmative	
5	Massachusetts Municipal Wholesale Electric Company	David Gordon	Abstain	
5	MEAG Power	Steven Grego	Affirmative	
5	Muscatine Power & Water	Mike Avesing	Affirmative	
5	Nebraska Public Power District	Don Schmit	Affirmative	
5	Nevada Power Co.	Richard Salgo	Affirmative	
5	New York Power Authority	Wayne Sipperly	Affirmative	
5	NextEra Energy	Allen D Schriver	Affirmative	
5	North Carolina Electric Membership Corp.	Jeffrey S Brame		
5	Northern Indiana Public Service Co.	Michael D Melvin		
5	Oglethorpe Power Corporation	Bernard Johnson	Affirmative	
5	Oklahoma Gas and Electric Co.	Henry L Staples	Affirmative	
5	Omaha Public Power District	Mahmood Z. Safi	Affirmative	
5	Orlando Utilities Commission	Richard K Kinias		
5	Pacific Gas and Electric Company	Alex Chua		
5	Platte River Power Authority	Christopher R Wood	Affirmative	
5	PPL Generation LLC	Annette M Bannon		
5	PSEG Fossil LLC	Tim Kucey	Affirmative	
5	Public Utility District No. 2 of Grant County, Washington	Michiko Sell	Affirmative	
5	Puget Sound Energy, Inc.	Lynda Kupfer	Abstain	

5	Sacramento Municipal Utility District	Susan Gill-Zobitz	Affirmative	
5	Salt River Project	William Alkema	Affirmative	
5	Santee Cooper	Lewis P Pierce		
5	Seattle City Light	Michael J. Haynes	Affirmative	
5	Seminole Electric Cooperative, Inc.	Brenda K. Atkins		
5	Snohomish County PUD No. 1	Sam Nietfeld	Affirmative	
5	South Carolina Electric & Gas Co.	Edward Magic	Affirmative	
5	Southern Company Generation	William D Shultz	Affirmative	
5	Tacoma Power	Chris Mattson	Abstain	
5	Tampa Electric Co.	RJames Rocha		
5	Tennessee Valley Authority	Brandy B Spraker	Abstain	
5	Terra-Gen Power	Jessie Nevarez		
5	Tri-State Generation & Transmission Association, Inc.	Mark Stein		
5	USDI Bureau of Reclamation	Erika Doot		
5	Westar Energy	Stephanie A Johnson	Affirmative	
5	Wisconsin Electric Power Co.	Linda Horn	Affirmative	
5	Wisconsin Public Service Corp.	Scott E Johnson		
5	Xcel Energy, Inc.	Mark A Castagneri	Affirmative	
6	AEP Marketing	Edward P. Cox	Negative	
6	Ameren Missouri	Robert Quinlivan	Negative	SUPPORTS THIRD PARTY COMMENTS - (Ameren)
6	APS	Randy A. Young		
6	Associated Electric Cooperative, Inc.	Brian Ackermann	Affirmative	
6	Bonneville Power Administration	Brenda S. Anderson	Affirmative	
6	City of Austin dba Austin Energy	Lisa Martin	Affirmative	
6	City of Redding	Marvin Briggs	Affirmative	
6	Cleco Power LLC	Robert Hirschak	Affirmative	
6	Colorado Springs Utilities	Shannon Fair	Affirmative	
6	Con Edison Company of New York	David Balban	Affirmative	
6	Constellation Energy Commodities Group	David J Carlson	Affirmative	
6	Dominion Resources, Inc.	Louis S. Slade		
6	Duke Energy	Greg Cecil		
6	FirstEnergy Solutions	Kevin Querry	Affirmative	
6	Florida Municipal Power Agency	Richard L. Montgomery	Affirmative	
6	Florida Municipal Power Pool	Thomas Reedy	Affirmative	
6	Florida Power & Light Co.	Silvia P Mitchell	Affirmative	
6	Great River Energy	Donna Stephenson	Affirmative	
6	Kansas City Power & Light Co.	Jessica L Klinghoffer	Affirmative	
6	Lakeland Electric	Paul Shipps		
6	Lincoln Electric System	Eric Ruskamp	Affirmative	
6	Los Angeles Department of Water & Power	Brad Packer		
6	Lower Colorado River Authority	Michael Shaw	Abstain	
6	Luminant Energy	Brenda Hampton		
6	Manitoba Hydro	Blair Mukanik	Affirmative	
6	Modesto Irrigation District	James McFall	Affirmative	
6	New York Power Authority	Shivaz Chopra	Affirmative	
6	New York State Electric & Gas Corp.	Julie S King	Affirmative	
6	Northern Indiana Public Service Co.	Joseph O'Brien	Abstain	
6	Oglethorpe Power Corporation	Donna Johnson		
6	Oklahoma Gas and Electric Co.	Jerry Nottmagel	Affirmative	
6	Omaha Public Power District	Douglas Collins	Affirmative	
6	Orlando Utilities Commission	Claston Augustus Sunanon		
6	PacifiCorp	Sandra L Shaffer	Affirmative	
6	Platte River Power Authority	Carol Ballantine	Affirmative	
6	Portland General Electric Co.	Shawn P Davis	Affirmative	
6	Power Generation Services, Inc.	Stephen C Knapp		
6	PPL EnergyPlus LLC	Elizabeth Davis	Abstain	
6	PSEG Energy Resources & Trade LLC	Stephen York	Affirmative	
6	Sacramento Municipal Utility District	Diane Enderby	Affirmative	
6	Salt River Project	William Abraham	Affirmative	
6	Santee Cooper	Michael Brown		
6	Seattle City Light	Dennis Sismaet	Affirmative	
6	Seminole Electric Cooperative, Inc.	Trudy S. Novak	Affirmative	
6	Snohomish County PUD No. 1	Kenn Backholm	Affirmative	

6	Southern Company Generation and Energy Marketing	John J. Ciza	Affirmative	
6	Tacoma Public Utilities	Michael C Hill	Abstain	
6	Tampa Electric Co.	Benjamin F Smith II		
6	Tennessee Valley Authority	Marjorie S Parsons	Abstain	
6	Westar Energy	Tiffany Lake	Affirmative	
6	Western Area Power Administration - UGP Marketing	Mark Messerli		
6	Xcel Energy, Inc.	Peter Colussy	Affirmative	
7	Luminant Mining Company LLC	Stewart Rake		
7	Siemens Energy, Inc.	Frank R. McElvain	Abstain	
8		David L Kiguel	Negative	COMMENT RECEIVED
8		Roger C Zaklukiewicz	Affirmative	
8	Massachusetts Attorney General	Frederick R Plett	Affirmative	
9	City of Vero Beach	Ginny Beigel	Affirmative	
9	Commonwealth of Massachusetts Department of Public Utilities	Donald Nelson		
9	New York State Public Service Commission	Diane J Barney	Affirmative	
10	Florida Reliability Coordinating Council	Linda C Campbell	Affirmative	
10	Midwest Reliability Organization	Russel Mountjoy	Affirmative	
10	Northeast Power Coordinating Council	Guy V. Zito	Affirmative	
10	ReliabilityFirst	Anthony E Jablonski	Affirmative	
10	SERC Reliability Corporation	Joseph W Spencer	Affirmative	
10	Southwest Power Pool RE	Bob Reynolds		
10	Texas Reliability Entity, Inc.	Derrick Davis	Affirmative	
10	Western Electricity Coordinating Council	Steven L. Rueckert	Affirmative	

Legal and Privacy : 404.446.2560 voice : 404.467.0474 fax : 3353 Peachtree Road, N.E. : Suite 600, North Tower : Atlanta, GA 30326
 Washington Office: 1325 G Street, N.W. : Suite 600 : Washington, DC 20005-3801

[Account Log-In/Register](#)

Copyright © 2015 by the North American Electric Reliability Corporation. : All rights reserved.
 A New Jersey Nonprofit Corporation

Individual or group. (17 Responses)
Name (10 Responses)
Organization (10 Responses)
Group Name (7 Responses)
Lead Contact (7 Responses)
Question 1 (17 Responses)
Question 1 Comments (17 Responses)
Question 2 (16 Responses)
Question 2 Comments (17 Responses)

Group
Northeast Power Coordinating Council
Guy Zito
No
Sub-Parts 4.2.6 and 4.2.6.1 can be combined into one sub-Part 4.2.6 to read: 4.2.6 Protection Systems and Sudden Pressure Relaying for BES dispersed power producing Facilities identified through Inclusion I4 of the BES definition.
No
Individual
Reena Dhir
Manitoba Hydro
Yes
No
Individual
David Kiguel
David Kiguel
No
The meaning of the phrase "for generators not identified through Inclusion I4 of the BES definition," inserted in Section 4.2.5 of PRC-005-5 is not clear. If the intent is to include protections for generators that are not BES because they are not captured by Inclusion I4 of the BES definition, I suggest inserting the word "and" so the applicability is clearly stated as "Protection Systems and Sudden Pressure Relaying for (a) generator Facilities that are part of the BES, and (b) generator Facilities that are not identified through Inclusion I4 of the BES definition."
No
Individual
Jeremy Voll
Basin Electric Power Cooperative
Yes
Yes
Section 4.2.5 Protection Systems and Sudden Pressure Relaying for generator Facilities that are part of the BES, for generators not identified through Inclusion I4 of the BES definition, including: The inclusion of the "for generators not identified through Inclusion I4 of the BES definition" is worded in a way that makes it sound like all generators that are not BES also need to be subject to this standard. This is the wrong approach to the standard as it would then make every generator applicable to PRC-005. This should be removed from the applicability section.

Group
OG&E Compliance
Don Hargrove
Yes
Yes
The language in 4.2.5 is a little confusing until you read 4.2.6, and still it does not read clearly. We suggest modifying the language as follows. It doesn't change the meaning, but makes it easier to understand. CURRENT - 4.2.5 Protection Systems and Sudden Pressure Relaying for generator Facilities that are part of the BES, for generators not identified through Inclusion I4 of the BES definition, including: SUGGESTED - 4.2.5 Protection Systems and Sudden Pressure Relaying for generator Facilities that are part of the BES and not identified through Inclusion I4 of the BES definition, including:
Individual
Craig Jones
Idaho Power
Yes
No
Group
Associated Electric Cooperative, Inc.
Phil Hart
Yes
Although AECI agrees with the intent of the language, applicability section 4.2.5 could use some clarity. Suggested language: "Protection Systems and Sudden Pressure Relaying for generator Facilities that are included within the BES definition, but not identified through Inclusion I4, including:"
Group
SPP Standards Review Group
Robert Rhodes
No
The structure of 4.2.5 under Applicability is awkward and unclear. We suggest revising 4.2.5 to read 'Protection Systems and Sudden Pressure Relaying for generator Facilities that are part of the BES but not included through Inclusion I4 of the BES definition, including:'
No
Individual
Thomas Foltz
American Electric Power
No
Facilities Section 4.2.5: There appears to be a "stranded paragraph" under section 4.2.5.2 "Protection Systems and Sudden Pressure Relaying for station service or excitation transformers connected to the generator bus of generators which are part of the BES, that act to trip the generator either directly or via lockout or tripping auxiliary relays." Should this paragraph instead be classified as 4.2.5.3? 4.2.6: The word "facilities" should be removed from 4.2.6.1 so that it reads "Protection Systems and Sudden Pressure Relaying used in aggregating...". We suspect its inclusion may have been unintentional, but if not, we request that the drafting team explain its inclusion.
Yes

AEP supports the overall efforts of the drafting team, and agree in principle with the apparent purpose and intent of the standard. Our negative vote is driven solely by the inclusion of the word "facilities" in 4.2.6.1 of the Applicability section.
Group
Dominion
Connie Lowe
Yes
No
Individual
Marc Donaldson
Tacoma Power
Yes
Yes
The Implementation Plan states, "Reliability Standard PRC-005-4, with its associated Implementation Plan, was adopted by the Board of Trustees on November 7, 2013." Version 4 of PRC-005 was adopted later than November 7, 2013.
Individual
William English
Consumers Energy Company
No
I agree with the proposed changes to 4.2 Facilities, however the Standard is missing the label 4.2.5.3 at the bottom of page 3. The Standard should not be approved until this error is corrected.
No
Individual
Sergio Banuelos
Tri-State Generation and Transmission Association, Inc.
Yes
Tri-State G&T believes the language in the Facilities Section 4.2.5 "Protection Systems and Sudden Pressure Relaying for generator Facilities that are part of the BES, for generators not identified through Inclusion I4 of the BES definition, including:" is confusing as it is currently written. We believe the intent was in the right place in trying to exclude the individual dispersed generating units. We would suggest possibly using language such as "Protection System and Sudden Pressure Relaying for generator Facilities that are part of the BES, with the exception of those generator units identified through Inclusion I4 of the BES definition, including:".
No
Individual
Mike Smith
Manitoba Hydro
Yes
No
Individual
David Jendras
Ameren

No
PRC-019-2, PRC-024-2, and PRC-006-2 apply to the individual dispersed generator if the protection applies to the individual unit, (in addition to or rather than the 75MVA aggregate). Thus, we advocate that PRC-005-5 should require maintenance of those Protection Systems on those individual units.
No
Group
Duke energy
Michael Lowman
Yes
Duke Energy would like to thank the SDT for its effort on this project and agrees with the changes made to PRC-005-5.
No
Group
DTE Electric Co.
Kathleen Black
No
We recommend that a statement specifically excluding individual generating units be added in Section 4.2.6.1. Section 4.2.5 should be restated to clarify its meaning, especially the phrase "for generators not identified through Inclusion I4 of the BES definition".
No
No Comments

Additional Comments:

ACES

Jason Marshall

1. Do you agree with the revisions proposed in PRC-005-5 to clarify applicability of PRC-005-4 to dispersed power producing resources included in the BES through Inclusion I4 of the BES definition? If not, please provide technical rationale for your disagreement, along with suggested language changes.

Yes:

No:

Comments: We conceptually agree with the changes, but believe the language in the applicability section requires refinement to accurately capture the intent of the changes. For example, section 4.2.6 states that the standard is applicable to "Protection Systems and Sudden Pressure Relaying for the following BES generator Facilities". Thus, one would expect the next subsection to be a list of Facilities. It is not. It refers to Protection Systems and Sudden Pressure Relaying Facilities which do not meet the NERC definition of Facility. A Facility is a set of electrical equipment that operates as a single BES Element. For example,

a line or generator would be a Facility. A Protection System and Sudden Pressure Relaying would be components of a Facility but they would not be Facilities themselves. We think this issue can be resolved very simply by combining sections 4.2.6 and 4.2.6.1, and instead read: “Protection Systems and Sudden Pressure Relaying for dispersed power producing resources, identified through the BES definition Inclusion I4, where those resources aggregate to greater than 75 MVA and connect to a common point of connection at or above 100 kV”.

2. Do you have any additional comments to assist the DGR SDT in further developing its recommendations?

Yes:

No:

Comments: We think that section 4.2.5 is written in a confusing manner. We suggest moving the clause “for generator not identified through Inclusion I4 of the BES definition” to a footnote. Section 4.2.5 could then be further modified to read: “Protection Systems and Sudden Pressure Relaying for non-dispersed generator Facilities”. By definition, Facilities are limited to the BES, so there is no need to repeat “that are part of the BES” in the applicability section. The footnote could further explain what is intended by non-dispersed generator Facilities. We think this will make it clearer to read and understand.

Consideration of Comments

Project 2014-01 Standards Applicability for Dispersed Generation Resources

The Project 2014-01 Drafting Team thanks all commenters who submitted comments on the standard. The standard was posted for a 45-day public comment period from December 8, 2014 through January 22, 2015. Stakeholders were asked to provide feedback on the standard and associated documents through a special electronic comment form. There were 17 sets of comments, including comments from approximately 64 different people from approximately 50 companies representing all 10 Industry Segments as shown in the table on the following pages.

All comments submitted may be reviewed in their original format on the standard's [project page](#).

This document contains the Project 2014-01 Standards Applicability for Dispersed Generation Resources (DGR) standard drafting team's (SDT) response to all industry comments received during this comment period. The DGR SDT encourages commenters to review its responses to ensure all concerns have been addressed. The DGR SDT notes that a significant majority of commenters agree with the DGR SDT's recommendations on the standards, but that specific concerns were expressed. Some comments supporting the DGR SDT's recommendations are discussed below but in most cases are not specifically addressed in this response. Also, several comments in response to specific questions are duplicated in other questions, and several commenters raise substantively the same concerns as others. Therefore, the DGR SDT's consideration of all comments is addressed in this section in summary form, with duplicate comments treated as a single issue. Any comments made on another standard are addressed in the DGR SDT's response to comments on that standard.

1. Summary Consideration

Based on the results from the recent comment and ballot period, it appears that industry overwhelmingly agrees with the DGR SDT's recommendations on applicability changes to PRC-005-5 to account for the unique characteristics of dispersed power producing resources¹ in the standard. However, there are some disagreements among stakeholders and suggestions for language revisions contained in industry comments. To the extent that there are comments beyond the scope of this SDT, those comments will be communicated to the appropriate team for consideration.

The DGR SDT has carefully reviewed and considered each stakeholder comment and has revised its recommendations where suggested changes improve clarity and are consistent with DGR SDT intent

¹ The terms "dispersed generation resources" and "dispersed power producing resources" are used interchangeably in Project 2014-01 because the former term was used in the Standards Authorization Request for the project, while the latter term is in line with terminology used in the revised definition of the BES.

and apparent industry consensus. Several commenters suggested non-substantive language changes for standard language as well as explanatory language, such as language in particular rationale boxes. The DGR SDT has carefully considered each comment and has implemented non-substantive revisions to further clarify the language included in section 4.2.5 based on comments received. The DGR SDT is not changing the intent of the standard modification.

All recommended changes are non-substantive as contemplated by the NERC Standard Processes Manual and therefore do not require an additional ballot. The DGR SDT's consideration of all comments follows.

2. General Comments

Multiple commenters recommended clarifying the language in 4.2.5. The DGR SDT agrees and has therefore made non-substantive revisions to the terms to clarify the intent of the DGR SDT.

One commenter recommended clarifying the language in 4.2.6.1. The DGR SDT agrees and has therefore made clarifying changes as appropriate.

One commenter noted that the Implementation Plan stated the date PRC-005-4, with its associated Implementation Plan, was adopted by the Board of Trustees was incorrect. The DGR SDT agrees that the date was stated incorrectly and has corrected.

3. PRC-005

At least one commenter suggested combining Sub-Parts 4.2.6 and 4.2.6.1 into one sub-Part. The DGR SDT thanks the commenter for the suggestion; however, the suggested revision does not account for the limitation to applicability as--the point where those resources aggregate to greater than 75 MVA to a common point of connection at 100 kV or above.

At least one commenter recommend that a statement specifically excluding individual generating units be added in Section 4.2.6.1. It is the position of the DGR SDT that 4.2.6.1. adequately excludes the individual generators as written.

More than one commenter noted that there appeared to be a "stranded paragraph" under section 4.2.5.2 and questioned whether the paragraph should be numbered as 4.2.5.3. The SDT has made the formatting and clarifying changes as appropriate.

One commenter noted that PRC-019-2, PRC-024-2, and PRC-006-2 apply to the individual dispersed generator if the protection applies to the individual unit, (in addition to or rather than the 75MVA aggregate), and advocated that PRC-005-5 should require maintenance of those Protection Systems on those individual units.

It is the DGR SDT's position that the proposed revisions to the standard adequately support reliability as written. Therefore, the DGR SDT declines to adopt this suggestion.

If you feel that your comment has been overlooked, please let us know immediately. Our goal is to give every comment serious consideration in this process. If you feel there has been an error or omission, you can contact the Director of Standards, Valerie Agnew, at 404-446-2566 or at valerie.agnew@nerc.net. In addition, there is a NERC Reliability Standards Appeals Process.²

² The appeals process is in the Standard Processes Manual: http://www.nerc.com/comm/SC/Documents/Appendix_3A_StandardsProcessesManual.pdf

- 1. **Do you agree with the revisions proposed in PRC-005-5 to clarify applicability of PRC-005-4 to dispersed power producing resources included in the BES through Inclusion I4 of the BES definition? If not, please provide technical rationale for your disagreement, along with suggested language changes.10**
- 2. **Do you have any additional comments to assist the DGR SDT in further developing its recommendations?.....13**

The Industry Segments are:

- 1 — Transmission Owners
- 2 — RTOs, ISOs
- 3 — Load-serving Entities
- 4 — Transmission-dependent Utilities
- 5 — Electric Generators
- 6 — Electricity Brokers, Aggregators, and Marketers
- 7 — Large Electricity End Users
- 8 — Small Electricity End Users
- 9 — Federal, State, Provincial Regulatory or other Government Entities
- 10 — Regional Reliability Organizations, Regional Entities

Group/Individual		Commenter	Organization	Registered Ballot Body Segment											
				1	2	3	4	5	6	7	8	9	10		
1.	Group	Guy Zito	Northeast Power Coordinating Council												X
Additional Member		Additional Organization		Region	Segment Selection										
1.	Alan Adamson	New York State Reliability Council, LLC		NPCC	10										
2.	David Burke	Orange and Rockland Utilities Inc.		NPCC	3										
3.	Greg Campoli	New York Independent System Operator		NPCC	2										
4.	Sylvain Clermont	Hydro-Quebec TransEnergie		NPCC	1										
5.	Kelly Dash	Consolidated Edison Co. of New York, Inc.		NPCC	1										
6.	Gerry Dunbar	Northeast Power Coordinating Council		NPCC	10										
7.	Kathleen Goodman	ISO - New England		NPCC	2										
8.	Michael Jones	National Grid		NPCC	1										
9.	Mark Kenny	Northeast Utilities		NPCC	1										
10.	Helen Lainis	Independent Electricity System Operator		NPCC	2										

Group/Individual	Commenter	Organization	Registered Ballot Body Segment											
			1	2	3	4	5	6	7	8	9	10		
11. Connie Lowe	Dominion Resources Services, Inc.	NPCC 5												
12. Alan MacNaughton	New Brunswick Power Corporation	NPCC 9												
13. Bruce Metruck	New York Power Authority	NPCC 6												
14. Silvia Parada Mitchell	NextEra Energy, LLC	NPCC 5												
15. Lee Pedowicz	Northeast Power Coordinating Council	NPCC 10												
16. Robert Pellegrini	The United Illuminating Company	NPCC 1												
17. Si Truc Phan	Hydro-Quebec TransEnergie	NPCC 1												
18. David Ramkalawan	Ontario Power Generation, Inc.	NPCC 5												
19. Brian Robinson	Utility Services	NPCC 8												
20. Paul Malozewski	Hydro One Networks Inc.	NPCC 1												
21. Brian Shanahan	National Grid	NPCC 1												
22. Wayne Sipperly	New York Power Authority	NPCC 5												
23. Ben Wu	Orange and Rockland Utilities Inc.	NPCC 1												
24. Peter Yost	Consolidated Edison Co. of New York, Inc.	NPCC 3												
2.	Group	Don Hargrove	OG&E Compliance	X		X		X	X					
Additional Member		Additional Organization	Region	Segment Selection										
1.	Terri Pyle	Oklahoma Gas and Electric Co.	SPP	1										
2.	Don Hargrove	Oklahoma Gas and Electric Co.	SPP	3										
3.	Leo Staples	Oklahoma Gas and Electric Co.	SPP	5										
4.	Jerry Nottnagel	Oklahoma Gas and Electric Co.	SPP	6										
3.	Group	Phil Hart	Associated Electric Cooperative, Inc.	X		X		X	X					
Additional Member		Additional Organization	Region	Segment Selection										
1.	Central Electric Power Cooperative		SERC	1, 3										
2.	KAMO Electric Cooperative		SERC	1, 3										
3.	M & A Electric Power Cooperative		SERC	1, 3										
4.	Northeast Missouri Electric Power Cooperative		SERC	1, 3										
5.	N.W. Electric Power Cooperative, Inc.		SERC	1, 3										
6.	Sho-Me Power Electric Cooperative		SERC	1, 3										
4.	Group	Robert Rhodes	SPP Standards Review Group		X									
Additional Member		Additional Organization	Region	Segment Selection										
1.	Kevin Foflygen	City Utilities of Springfield	SPP	1, 4										

Group/Individual	Commenter	Organization	Registered Ballot Body Segment																	
			1	2	3	4	5	6	7	8	9	10								
2.	Stephanie Johnson	Westar Energy	SPP	1, 3, 5, 6																
3.	Bo Jones	Westar Energy	SPP	1, 3, 5, 6																
4.	Tiffany Lake	Westar Energy	SPP	1, 3, 5, 6																
5.	Shannon Mickens	Southwest Power Pool	SPP	2																
6.	James Mizell	Westar Energy	SPP	1, 3, 5, 6																
7.	James Nail	City of Independence, MO	SPP	3, 5																
8.	Jason Smith	Southwest Power Pool	SPP	2																
9.	Ashley Stringer	Oklahoma Municipal Power Authority	SPP	4																
5.	Group	Connie Lowe	Dominion		X		X		X	X										
Additional Member Additional Organization Region Segment Selection																				
1.	Randi Heise	NERC Compliance Policy	NPCC	5																
2.	Louis Slade	NERC Compliance Policy	RFC	5, 6																
3.	Larry Nash	Electric Transmission Compliance	SERC	1, 3, 5, 6																
6.	Group	Michael Lowman	Duke energy		X		X		X	X										
Additional Member Additional Organization Region Segment Selection																				
1.	Doug Hils		RFC	1																
2.	Lee Schuster		FRCC	3																
3.	Dale Goodwine		SERC	5																
4.	Greg Cecil		RFC	6																
7.	Group	Kathleen Black	DTE Electric Co.				X	X	X											
Additional Member Additional Organization Region Segment Selection																				
1.	Kent Kujala	NERC Compliance	RFC	3																
2.	Daniel Herring	NERC Training & Standards Development	RFC	4																
3.	Mark Stefaniak	Merchant Operations	NPCC	5																
4.	David Szulczewski	DE-EE Relay Eng Supv																		
5.	Chris Divney	Relay Performance																		
8.	Individual	Reena Dhir	Manitoba Hydro		X		X		X	X										
9.	Individual	David Kiguel	David Kiguel																X	
10.	Individual	Jeremy Voll	Basin Electric Power Cooperative		X		X		X						X					
11.	Individual	Craig Jones	Idaho Power																	

Group/Individual		Commenter	Organization	Registered Ballot Body Segment									
				1	2	3	4	5	6	7	8	9	10
12.	Individual	Thomas Foltz	American Electric Power	X		X		X	X				
13.	Individual	Marc Donaldson	Tacoma Power	X		X	X	X	X				
14.	Individual	William English	Consumers Energy Company			X	X	X					
15.	Individual	Sergio Banuelos	Tri-State Generation and Transmission Association, Inc.	X		X		X					
16.	Individual	Mike Smith	Manitoba Hydro	X		X		X	X				
17.	Individual	David Jendras	Ameren	X		X		X	X				

If you support the comments submitted by another entity and would like to indicate you agree with their comments, please select "agree" below and enter the entity's name in the comment section (please provide the name of the organization, trade association, group, or committee, rather than the name of the individual submitter).

Organization	Agree	Supporting Comments of "Entity Name"
N/A	N/A	N/A

1. Do you agree with the revisions proposed in PRC-005-5 to clarify applicability of PRC-005-4 to dispersed power producing resources included in the BES through Inclusion I4 of the BES definition? If not, please provide technical rationale for your disagreement, along with suggested language changes.

Organization	Yes or No	Question 1 Comment
Northeast Power Coordinating Council	No	Sub-Parts 4.2.6 and 4.2.6.1 can be combined into one sub-Part 4.2.6 to read:4.2.6 Protection Systems and Sudden Pressure Relaying for BES dispersed power producing Facilities identified through Inclusion I4 of the BES definition.
SPP Standards Review Group	No	The structure of 4.2.5 under Applicability is awkward and unclear. We suggest revising 4.2.5 to read 'Protection Systems and Sudden Pressure Relaying for generator Facilities that are part of the BES but not included through Inclusion I4 of the BES definition, including:'
DTE Electric Co.	No	We recommend that a statement specifically excluding individual generating units be added in Section 4.2.6.1. Section 4.2.5 should be restated to clarify its meaning, especially the phrase "for generators not identified through Inclusion I4 of the BES definition".
David Kiguel	No	The meaning of the phrase "for generators not identified through Inclusion I4 of the BES definition," inserted in Section 4.2.5 of PRC-005-5 is not clear. If the intent is to include protections for generators that are not BES because they are not captured by Inclusion I4 of the BES definition, I suggest inserting the word "and" so the applicability is clearly stated as "Protection Systems and Sudden Pressure Relaying for (a) generator Facilities that are part of the BES, and (b) generator Facilities that are not identified through Inclusion I4 of the BES definition."
American Electric Power	No	Facilities Section4.2.5:There appears to be a “stranded paragraph” under section 4.2.5.2 “Protection Systems and Sudden Pressure Relaying for

Organization	Yes or No	Question 1 Comment
		<p>station service or excitation transformers connected to the generator bus of generators which are part of the BES, that act to trip the generator either directly or via lockout or tripping auxiliary relays.” Should this paragraph instead be classified as 4.2.5.3?</p> <p>4.2.6: The word “facilities” should be removed from 4.2.6.1 so that it reads “Protection Systems and Sudden Pressure Relaying used in aggregating...”. We suspect its inclusion may have been unintentional, but if not, we request that the drafting team explain its inclusion.</p>
Consumers Energy Company	No	I agree with the proposed changes to 4.2 Facilities, however the Standard is missing the label 4.2.5.3 at the bottom of page 3. The Standard should not be approved until this error is corrected.
Ameren	No	PRC-019-2, PRC-024-2, and PRC-006-2 apply to the individual dispersed generator if the protection applies to the individual unit, (in addition to or rather than the 75MVA aggregate). Thus, we advocate that PRC-005-5 should require maintenance of those Protection Systems on those individual units.
OG&E Compliance	Yes	
Associated Electric Cooperative, Inc.	Yes	Although AECEI agrees with the intent of the language, applicability section 4.2.5 could use some clarity. Suggested language: "Protection Systems and Sudden Pressure Relaying for generator Facilities that are included within the BES definition, but not identified through Inclusion I4, including:"
Dominion	Yes	
Duke energy	Yes	Duke Energy would like to thank the SDT for its effort on this project and agrees with the changes made to PRC-005-5.

Organization	Yes or No	Question 1 Comment
Manitoba Hydro	Yes	
Basin Electric Power Cooperative	Yes	
Idaho Power	Yes	
Tacoma Power	Yes	
Tri-State Generation and Transmission Association, Inc.	Yes	<p>Tri-State G&T believes the language in the Facilities Section 4.2.5 "Protection Systems and Sudden Pressure Relaying for generator Facilities that are part of the BES, for generators not identified through Inclusion I4 of the BES definition, including:" is confusing as it is currently written. We believe the intent was in the right place in trying to exclude the individual dispersed generating units. We would suggest possibly using language such as "Protection System and Sudden Pressure Relaying for generator Facilities that are part of the BES, with the exception of those generator units identified through Inclusion I4 of the BES definition, including:".</p>
Manitoba Hydro	Yes	

2. Do you have any additional comments to assist the DGR SDT in further developing its recommendations?

Organization	Yes or No	Question 2 Comment
Northeast Power Coordinating Council	No	
SPP Standards Review Group	No	
Dominion	No	
Duke energy	No	
DTE Electric Co.	No	No Comments
Manitoba Hydro	No	
David Kiguel	No	
Idaho Power	No	
Consumers Energy Company	No	
Tri-State Generation and Transmission Association, Inc.	No	
Manitoba Hydro	No	
Ameren	No	

Organization	Yes or No	Question 2 Comment
OG&E Compliance	Yes	The language in 4.2.5 is a little confusing until you read 4.2.6, and still it does not read clearly. We suggest modifying the language as follows. It doesn't change the meaning, but makes it easier to understand. CURRENT - 4.2.5 Protection Systems and Sudden Pressure Relaying for generator Facilities that are part of the BES, for generators not identified through Inclusion I4 of the BES definition, including: SUGGESTED - 4.2.5 Protection Systems and Sudden Pressure Relaying for generator Facilities that are part of the BES and not identified through Inclusion I4 of the BES definition, including:
Basin Electric Power Cooperative	Yes	Section 4.2.5 Protection Systems and Sudden Pressure Relaying for generator Facilities that are part of the BES, for generators not identified through Inclusion I4 of the BES definition, including: The inclusion of the "for generators not identified through Inclusion I4 of the BES definition" is worded in a way that makes it sound like all generators that are not BES also need to be subject to this standard. This is the wrong approach to the standard as it would then make every generator applicable to PRC-005. This should be removed from the applicability section.
American Electric Power	Yes	AEP supports the overall efforts of the drafting team, and agree in principle with the apparent purpose and intent of the standard. Our negative vote is driven solely by the inclusion of the word "facilities" in 4.2.6.1 of the Applicability section.
Tacoma Power	Yes	The Implementation Plan states, "Reliability Standard PRC-005-4, with its associated Implementation Plan, was adopted by the Board of Trustees on November 7, 2013." Version 4 of PRC-005 was adopted later than November 7, 2013.

END OF REPORT

Draft White Paper

Proposed Revisions to the Applicability of NERC Reliability Standards NERC Standards Applicability to Dispersed Generation Resources

**Project 2014-01 Standards Applicability for Dispersed
Generation Resources Standard Drafting Team**

December 11, 2014

Table of Contents

1	EXECUTIVE SUMMARY	3
2	PURPOSE	5
3	BACKGROUND	6
3.1	BES DEFINITION	6
3.2	DISPERSED GENERATION RESOURCES	7
3.3	DRAFTING TEAM EFFORTS	8
4	TECHNICAL DISCUSSION	11
4.1	BAL	11
4.2	COM	11
4.3	EOP	11
4.4	FAC	12
4.5	INT	13
4.6	IRO.....	13
4.7	MOD	14
4.8	NUC	16
4.9	PER	16
4.10	PRC	16
4.11	TOP	22
4.12	TPL.....	27
4.13	VAR.....	28
4.14	CIP	29
	APPENDIX A: LIST OF STANDARDS	32
	APPENDIX B: LIST OF STANDARDS RECOMMENDED FOR FURTHER REVIEW	33

1 Executive Summary

The purpose of this White Paper is to provide background and technical rationale for proposed revisions to the applicability of several North American Electric Reliability Corporation (NERC) Reliability Standards, and in some cases the standard requirements. The goal of the NERC Project 2014-01 Standards Applicability for Dispersed Generation Resources¹ standard drafting team (SDT) is to ensure that the Generator Owners (GOs) and Generator Operators (GOPs) of dispersed power producing resources are appropriately assigned responsibility for requirements that impact the reliability of the Bulk Power System (BPS), as the characteristics of operating dispersed power producing resources can be unique. In light of the revised Bulk Electric System (BES) definition approved by the Federal Energy Regulatory Authority (FERC) in 2014², the intent of this effort is generally to maintain the status quo for applicability of the standards as they have been applied over time with respect to dispersed power producing resources where the status quo does not create a reliability gap.

The SDT reviewed all standards that apply to GOs and GOPs³ and determined how each standard requirement should be appropriately applied to dispersed power producing resources, categorized as follows:

- The existing standard language was appropriate when applied to dispersed power producing resources and does not need to be addressed;
- The existing standard language was appropriate when applied to dispersed power producing resources but additional NERC guidance documentation is needed to clarify how to implement the requirements for dispersed power producing resources; and
- The existing standard language needs to be modified in order to account for the unique characteristics of dispersed power producing resources. This could be accomplished through the Applicability Section of the standard in most cases or, if required, through narrowly-tailored changes to the individual requirements.

From this review, the SDT determined that three (3) Reliability Standards required immediate attention to clarify the applicability of the Reliability Standards to dispersed power producing resources for the benefit of industry stakeholders. These standards are:

- PRC-004 (relevant versions)⁴;
- PRC-005 (relevant versions)⁵; and
- VAR-002 (relevant versions).

The SDT recognized that many other standards⁶ required further review to determine the necessity and the type of clarification or guidance for the applicability to dispersed power producing resources. This

¹ Although the BES definition uses the term “dispersed power producing resources,” the SAR and the SDT also use the term “dispersed generation resources.” For the purposes of this paper, these terms are interchangeable.

² Glossary of Terms Used in NERC Reliability Standards, updated March 12, 2014.

³ See Appendix A.

⁴ Reliability Standard PRC-004 was revised as part of Project 2010-05.1 Protection Systems: Misoperations.

⁵ Reliability Standard PRC-005 was revised as part of Project 2007-17.3 – Protection System Maintenance and Testing – Phase 3.

⁶ See Appendix B.

necessity is based on how each standard requirement, as written, would apply to dispersed power producing resources and the individual generating units at these facilities, considering the now currently-enforced BES definition. The proposed resolutions target the applicability of the standard or target specific individual requirements. There are additional methods to ensure consistent applicability throughout the Regions, including having guidance issued by NERC through Reliability Standard Audit Worksheet (RSAW) language revisions. These tools, among others, have been considered and employed by the SDT throughout the drafting effort.

The White Paper includes: 1) description of the history of standards applicability to dispersed power producing resources; 2) identification of circumstances and practices that are unique to dispersed power producing resources; and 3) determination of the priority to address standards, supported by corresponding technical justification.

It is the intent of the SDT to modify this document over the course of this project to document the SDT's rationale and technical justification for each standard until the work of the SDT is complete. The SDT considers the sections of the White Paper that address the high-priority standards to be in final draft form. The SDT may provide further revisions to the remainder of the White Paper.

2 Purpose

The purpose of this White Paper is to provide background and technical rationale for proposed revisions to the applicability of several Reliability Standards⁷ or requirements that apply to GOs and/or GOPs. The goal of the proposed applicability changes is to provide the GOs and GOPs of dispersed generation resources with clarity regarding their responsibility for requirements that impact the reliability of the BPS, as the characteristics of operating dispersed generation can be unique. The SDT seeks to provide clarity through the method most appropriate for each standard, such as by: (1) revising applicability language in the standard; (2) revising language in the requirements to address changes to applicability; (3) recommending changes to the RSAW associated with the standard; or (4) recommending a reliability guideline or reference document.

This document describes the design, operational characteristics, and unique features of dispersed power producing resources. The recommendations identified in this document consider the Purpose and Time Horizon of the standards and requirements, as well as the avoidance of applying requirements in a manner that has no significant effect on reliability.⁸ This document provides justification of, and proposes revisions to, the applicability of the Reliability Standards and requirements, both existing and in development, and should be considered guidance for future standard development efforts. However, please note that the recommendations provided in this paper are subject to further review and revision.

Note that while this White Paper may provide examples of dispersed power producing resources, the concepts presented are not specific to any one technology. The SDT in general has referenced the BES Reference Document, which also refers to “dispersed power producing resources.” Although the BES definition uses the term “dispersed power producing resources,” the Standard Authorization Request (SAR) and the SDT also use the term “dispersed generation resources.” For the purposes of this paper, these terms are interchangeable.

⁷ Note that “Reliability Standard” is defined in the NERC Glossary as “approved by FERC,” but that the SDT reviewed approved standards, as well as revisions to standards proposed in other projects.

⁸ *North American Electric Reliability Corporation*, 138 FERC ¶ 61,193 at P 81 (2012).

3 Background

Industry stakeholders submitted a SAR to the NERC Standards Committee, requesting that the applicability of Reliability Standards or the requirements of Reliability Standards be revised to ensure that the Reliability Standards are not imposing requirements on dispersed generation resource components that are unnecessary or counterproductive to the reliability of the BPS. The SDT's focus has been to ensure that Reliability Standards are applied to dispersed power producing resources to support an effective defense-in-depth strategy and an adequate level of reliability for the interconnected BPS.

For purposes of this effort, dispersed power producing resources are those individual resources that aggregate to a total capacity greater than 75 MVA gross nameplate rating, and that are connected through a system designed primarily for delivering such capacity to a common point of connection at a voltage of 100 kV or above. This request is related to the approved definition of the BES from Project 2010-17,⁹ which resulted in the inclusion of distinct components of dispersed generation resources.

3.1 BES Definition

The BES definition¹⁰ includes the following inclusion criterion addressing dispersed generation resources:

I4. Dispersed power producing resources that aggregate to a total capacity greater than 75 MVA (gross nameplate rating), and that are connected through a system designed primarily for delivering such capacity to a common point of connection at a voltage of 100 kV or above. Thus, the facilities designated as BES are:

- a) The individual resources, and*
- b) The system designed primarily for delivering capacity from the point where those resources aggregate to greater than 75 MVA to a common point of connection at a voltage of 100 kV or above.*

The *BES Definition Reference Document*¹¹ includes a description of what constitutes dispersed generation resource:

“Dispersed power producing resources are small-scale power generation technologies using a system designed primarily for aggregating capacity providing an alternative to, or an enhancement of, the traditional electric power system. Examples could include but are not limited to: solar, geothermal, energy storage, flywheels, wind, micro-turbines, and fuel cells.”

⁹ http://www.nerc.com/pa/Stand/Pages/Project2010-17_BES.aspx

¹⁰ Glossary of Terms Used in NERC Reliability Standards, updated March 12, 2014.
http://www.nerc.com/pa/Stand/Glossary%20of%20Terms/Glossary_of_Terms.pdf

¹¹ Bulk Electric System Definition Reference Document, Version 2, April 2014.
http://www.nerc.com/pa/Stand/Project%20201017%20Proposed%20Definition%20of%20Bulk%20Electri/bes_phase2_reference_document_20140325_final_clean.pdf.

3.2 Dispersed Power Producing Resources

Dispersed power producing resources are often considered to be variable energy resources such as wind and solar. This description is not explicitly stated in the BES definition; however, NERC and FERC characterize variable generation in this manner regarding the purpose of Inclusion I4 of the definition.¹² Therefore, the SDT is considering the reliability impacts of variable generation that depends on a primary fuel source which varies over time and cannot be stored.¹³ Reliably integrating high levels of variable resources – wind, solar, ocean, and some forms of hydro – into the BPS require significant changes to traditional methods used for system planning and operation.¹⁴ While these resources provide challenges to system operation, these resources are instrumental in meeting government-established renewable portfolio standards and requirements that are based on vital public interests.¹⁵

3.2.1 Design Characteristics

For dispersed power producing resources to be economically viable, it is necessary for the equipment to be geographically dispersed. The generating capacity of individual generating modules can be as small as a few hundred watts to as large as several megawatts. Factors leading to this dispersion requirement include:

- Practical maximum size for wind generators to be transported and installed at a height above ground to optimally utilize the available wind resource;
- Spacing of wind generators geographically to avoid interference between units;
- Solar panel conversion efficiency and solar resource concentration to obtain usable output; and
- Cost-effective transformation and transmission of electricity.

The utilization of small generating units results in a large number of units (e.g., several hundred wind generators or several million solar panels) installed collectively as a single facility that is connected to the Transmission system.

Dispersed power producing resources interconnected to the transmission system typically have a control system at the group level that controls voltage and power output of the Facility. The control system is capable of recognizing the capability of each individual unit or inverter to appropriately distribute the contribution required of the Facility across the available units or inverters. The variable generation control system must also recognize and account for the variation of uncontrollable factors such as wind speed and solar irradiance levels. Thus, for some standards discussed in this paper it is appropriate to apply requirements at the plant level rather than the individual generating unit.

¹² NERC December 13, 2013 filing, page 15 (FERC Docket No. RD14-2); NERC December 13, 2013 filing, page 17 (FERC Docket No. RD14-2); NERC January 25, 2012 filing, page 18 (FERC Docket No. RD14-2), FERC Order Approving Revised Definition, Docket No. RD14-2-000, Issued March 20, 2014.

¹³ “*Electricity Markets and Variable Generation Integration*,” WECC, January 6, 2011.

¹⁴ “*Accommodating High Levels of Variable Generation*,” NERC, April, 2009. http://www.nerc.com/files/ivgtf_report_041609.pdf

¹⁵ See *Rules Concerning Certification of the Electric Reliability Organization; and Procedures for the Establishment, Approval, and Enforcement of Electric Reliability Standards*, Order No. 672, FERC Stats. & Regs. ¶ 31,204, at P 335, *order on reh’g*, Order No. 672-A, FERC Stats. & Regs. ¶ 31,212 (2006).

3.2.2 Operational Characteristics

Dispersed power producing resources often rely on a variable energy source (wind, for example) that is not able to be stored. Because of this, a Facility operator cannot provide a precise forecast of the expected output to a Balancing Authority (BA), Transmission Operator (TOP) or Reliability Coordinator (RC); however, short-term forecasting capability is improving and thus reducing uncertainty.¹⁶ The forecasting and variable operating conditions are well understood by BAs, TOPs, and RCs as evidenced by the successful operation of these generating resources over the years. Dispersed generation resources by their nature result in each individual generating unit potentially experiencing varied power system parameters (e.g. voltage, frequency, etc.) due to varied impedances and other variations in the aggregating facilities design.

Many older dispersed power producing resources are limited in their ability to provide essential reliability services. However, due to technological improvements, newer dispersed generation resources are capable of providing system support for voltage and frequency. For efficiency, the facilities are designed to provide the system requirements at the point of interconnection to the transmission system.

3.2.3 Reliability Impact

A dispersed power producing resource is typically made up of many individual generating units. In most cases, the individual generating units are similar in design and from one manufacturer. The aggregated capability of the Facility may in some cases contribute significantly to the reliability of the BPS. As such, there can be reliability benefits from ensuring the equipment utilized to aggregate the individual units to a common point of connection are operated and maintained as required in certain applicable NERC standards. When evaluated individually, however, the individual generating units often do not provide a significant impact to BPS reliability, as the unavailability or failure of any one individual generating resource may have a negligible impact on the aggregated capability of the Facility. The SDT acknowledges that FERC addressed the question of whether individual resources should be included in the BES definition in Order Nos. 773 and 773-A and concluded that individual wind turbine generators should be included as part of the BES. The SDT is not challenging this conclusion, but rather is addressing the applicability of standards on a requirement-by-requirement basis as necessary to account for the unique characteristics of dispersed generation. Thus, the applicability of requirements to individual generating units may be unnecessary except in cases where a common mode issue exists that could lead to a loss of a significant number of units or the entire Facility in response to a transmission system event.

3.3 Drafting Team Efforts

The SDT approached this project in multiple phases. First, after a thorough discussion of the new definition of the BES, the SDT reviewed each standard, as shown in Appendix A, at a high level to recommend changes that would promote consistent applicability for dispersed power producing resources through the entire set of Reliability Standards. This review provided the type of changes proposed, the justification for the changes, and the priority of the changes. The SDT documented its review in this

¹⁶ “*Electricity Markets and Variable Generation Integration*,” WECC, January 6, 2011. <https://www.wecc.biz/committees/StandingCommittees/JGC/VGS/MWG/ActivityM1/WECC%20Whitepaper%20-%20Electricity%20Markets%20and%20Variable%20Generation%20Integration.pdf>

White Paper, which will continue to be updated throughout the SDT efforts. The second phase, currently in progress, includes revising standards where necessary and supporting the balloting and commenting process.

3.3.1 Scope of Standards Reviewed

Initially, the focus of the standards review was on standards and requirements applicable to GOs and GOPs. However, during discussions, a question was raised to the SDT whether consideration is necessary for other requirements that affect the interaction of a Balancing Authority (BA), Transmission Operator (TOP), or Reliability Coordinator (RC) with individual BES Elements. For example, a requirement that states “an RC shall monitor BES Elements” may unintentionally affect the RC operator due to the revised BES definition. As such, the SDT took a high-level look at all standards adopted by the NERC Board of Trustees (Board) or approved by FERC to ensure this issue was not significant.

All standards that were reviewed are listed in Appendix A along with the status of the standards as of December 11, 2014. The fields in Appendix A include the following:

- List of standards (grouped by approval status);
- Approval status of the standards which include
 - Subject to Enforcement
 - Subject to Future Enforcement
 - Filed and Pending Regulatory Approval
 - Pending Regulatory Filing
 - Designated for Retirement (2 standards – MOD-024-1 and MOD-025-1 – officially listed as Filed and Pending Regulatory Approval but will be superseded by MOD-025-2)
 - In concurrent active development; and
- Indication of change or additional review necessary.

The SDT also reviewed, at a high-level, any approved regional standards. In cases where a change is recommended to a regional standard, the SDT will notify the affected Region. In addition, the SDT is prepared to provide recommendations to other active NERC standard development efforts, where appropriate.

Status	Number of Standards	Number of Standards to be Addressed (Standard, RSAW, Guidance or Further Review)
NERC Standards	166	27
Subject to Enforcement	101	12
Subject to Future Enforcement	20	5
Pending Regulatory Approval	28	4
Pending Regulatory Filing	7	0
Designated for Retirement	2	0
Proposed for Remand	8	6
Region-specific Standards (*Out of Scope)	17	4
Subject to Enforcement	15	3
Subject to Future Enforcement	2	1
Pending Regulatory Approval	0	0
Grand Total	183	31

3.3.2 Reliability Objectives

The SDT used the following Reliability Objectives to review the standards:

- Interconnected bulk power systems shall be planned and operated in a coordinated manner to perform reliably under normal and abnormal conditions as defined in the NERC Standards;
- The frequency and voltage of interconnected bulk power systems shall be controlled within defined limits through the balancing of real and reactive power supply and demand;
- Information necessary for the planning and operation of interconnected bulk power systems shall be made available to those entities responsible for planning and operating the systems reliably;
- Plans for Emergency operation and system restoration of interconnected bulk power systems shall be developed, coordinated, maintained, and implemented;
- Facilities for communication, monitoring, and control shall be provided, used, and maintained for the reliability of interconnected bulk power systems;
- Personnel responsible for planning and operating interconnected bulk power systems shall be trained, qualified, and have the responsibility and authority to implement actions;
- The reliability of the interconnected bulk power systems shall be assessed, monitored, and maintained on a wide-area basis; and
- Bulk power systems shall be protected from malicious physical or cyber attacks.

3.3.3 Prioritization Methodology

The SDT established a prioritization to review and modify applicability changes recommended to NERC standards and requirements. The SDT evaluated each requirement to identify the appropriate applicability to support reliability of the BPS. In general, any standard or requirement the SDT determined required modification was assigned a high, medium, or low priority. The standards and requirements priorities were established as follows:

- High priority was assigned so that standard or requirement changes would be made quickly enough to avoid an entity having to expend inordinate resources prematurely to comply with a standard or requirement that, after appropriate modification, would not be applicable to that entity;
- Medium priority was assigned if significant effort and resources with no appreciable reliability benefit would be required by an entity to be compliant; and
- Low priority was assigned to other changes that may need to be made to further ensure requirements add to reliability, but are not perceived as a significant compliance burden.

The prioritization of each recommendation is identified in Appendix B.

- List of standards (grouped by priority);
- Approval status of the standards (same designations as used in Appendix A);
- Recommendation of changing the Applicability Section of the standard or by changing the applicability for specific requirements; and
- Recommendation of which applicability options should apply.

4 Technical Discussion

This section provides a review of each group of standards, focusing on the impact of the BES definition on reliability and compliance efforts. This discussion proposes a resolution for each standard, whether it is a change in the Applicability Section or in a specific requirement, clarification in a guidance document, or no action needed.

4.1 BAL

The group of BAL standards focuses primarily on ensuring the Balancing Authority (BA) has the awareness, ability, and authority to maintain the frequency and operating conditions within its BA Area. Only two standards in this group affect GO and/or GOP, and no BAL standard reviewed affected the interaction of a host BA, TOP, or RC with individual BES Elements.

4.1.1 BAL-005 — Automatic Generation Control

The purpose of this standard, as it applies to GOPs, is to ensure that all facilities electrically synchronized to the Interconnection are included within the metered boundary of a BA Area so that balancing of resources and demand can be achieved. Ensuring the Facility as a whole is within a BA Area ensures the individual units are included. *Therefore, the applicability of the BAL-005 standard does not need to be changed for dispersed power producing resources.*

4.1.2 BAL-001-TRE-1 — Primary Frequency Response in the ERCOT Region

The purpose of BAL-001-TRE-1 standard is to maintain Interconnection steady-state frequency within defined limits. This standard should be modified to clarify the applicability for dispersed power producing resources to the total plant level to ensure coordinated performance. However, this is a regional standard and not part of the SDT scope. *The SDT will communicate this recommendation to the relevant Region.*

4.2 COM

The COM standards focus on communication between the RC, BAs, TOPs, and GOPs. The only requirements in any of the current or future enforceable standards that apply to the GOP are clearly intended to apply to the individual GOP registered functional entity (i.e., requires communication between GOPs, TOPs, BAs, and RCs), not the constituent Elements it operates. Consequently, there is no need to differentiate the GOPs obligation for dispersed power producing resources from any other resources. *Therefore, the applicability of the COM-001-2, COM-002-2a, and COM-002-4 standards that were reviewed do not need to be changed for dispersed power producing resources.*

4.3 EOP

The EOP standards focus on emergency operations and reporting. The standards that apply to GO and/or GOP entities are EOP-004 and EOP-005. No EOP standard reviewed affects the interaction of a host BA, TOP, or RC with individual BES Elements.

4.3.1 EOP-004 — Event Reporting

The purpose of this standard is to improve the reliability of the BES by requiring the reporting of events by Responsible Entities. The requirements of this standard that apply to the GO and GOP appear to apply

to the individual GO and GOP registered functional entity, not the constituent elements. *The SDT has considered whether there is a need to differentiate dispersed power producing resources from any other GO and/or GOP resource and determined that no changes are required to the standard.*

4.3.2 EOP-005 — System Restoration from Blackstart Resources

EOP-005 ensures plans are in place to restore the grid from a de-energized state. The requirements that apply to a GOP are primarily for individual generation facilities designated as Blackstart Resources, with one requirement to participate in restoration exercises or simulations as requested by the RC. The inclusion of Blackstart Resources is already identified in the BES definition through Inclusion I3. The expectation is that all registered GOPs will participate in restoration exercises as requested by its RC. *Therefore, the applicability of EOP-005 does not need to be changed for dispersed power producing resources.*

4.4 FAC

The FAC standards focus on establishing ratings and limits of the Facility and interconnection requirements to the BES. Several standards apply to GOs and/or GOPs. No FAC standard reviewed affects the interaction of a host BA, TOP, or RC with individual BES Elements.

4.4.1 FAC-001 — Facility Connection Requirements

Requirements R2 and R3 of this standard apply to any GO that has an external party applying for interconnection to the GO's existing Facility in order to connect to the transmission system. This scenario is uncommon and there is no precedent for applicability of this standard to dispersed *power producing* resources known to the SDT. Current practice primarily includes the GO stating that they will comply with the standard if this scenario is ever realized. This standard allows the GO to specify the conditions that must be met for the interconnection of the third-party, thus providing inherent flexibility to tailor the requirements specifically for the unique needs of the Facility. *Therefore, the applicability of FAC-001 does not need to be changed for dispersed power producing resources.*

4.4.2 FAC-002 — Coordination of Plans for New Facilities

The purpose of FAC-002 is to ensure coordinated assessments of new facilities. The requirement applicable to GOs requires coordination and cooperation on assessments to demonstrate the impact of new facilities on the interconnected system and to demonstrate compliance with NERC standards and other applicable requirements. The methods used to demonstrate compliance are independent of the type of generation and are typically completed at the point of interconnection. *Therefore, the applicability of FAC-002 does not need to be changed for dispersed power producing resources.*

4.4.3 FAC-003 — Transmission Vegetation Management

The purpose of this standard is to ensure programs and efforts are in place to prevent vegetation-related outages. This standard applies equally to dispersed generation facilities and traditional Facilities in both applicability and current practices, as it pertains to overhead transmission lines of applicable generation interconnection Facilities. *Therefore, the applicability of FAC-003 does not need to be changed for dispersed power producing resources.*

4.4.4 FAC-008 — Facility Ratings

FAC-008 ensures Facility ratings used in the planning and operation of the BES are established and communicated. The Facility ratings requirement has historically been applicable to dispersed power producing resources and current practices associated with compliance are similar to traditional generation facilities. There is inherent flexibility in the standard requirements for the GO to determine the methodology utilized in determining the Facility ratings.

To identify the Facility rating of a dispersed power producing resource the analysis of the entire suite of Facility components is necessary to adequately identify the minimum and maximum Facility Rating and System Operating Limits, and thus there would be no differentiation between the compliance obligations between dispersed power producing resources and traditional generation. *The SDT believes the industry and Regions would benefit from additional guidance on FAC-008 in the form of changes to add a technical guidance section to the standard, or other guidance.*

4.5 INT

The INT standards provide BAs the authority to monitor power interchange between BA Areas. No INT standard is applicable to the GO or GOP, or affects the interaction of a host BA, TOP, or RC with individual BES Elements. *Therefore, the applicability of the INT standards do not need to be changed for dispersed power producing resources.*

4.6 IRO

The IRO standards provide RCs their authority. There are three IRO Standards that apply directly to GO and/or GOP entities. There are three standards that apply to the interaction of the RC with individual BES Elements. No other IRO standard reviewed affected the interaction of a host BA, TOP, or RC with GOs and/or GOPs.

4.6.1 IRO-001 — Reliability Coordination — Responsibilities and Authorities¹⁷

The purpose of these standards and their requirements as applicable to a GOP is to ensure RC directives are complied with so long as they do not violate safety, equipment, or regulatory or statutory requirements, or cannot be physically implemented. If a GOP is unable to follow a RC directive they are to inform the RC immediately of such.

Directives from RCs have been traditionally applied to the dispersed power producing resource at the aggregate Facility level when they are related to either active power or voltage, such as an output reduction or the provision of voltage support. When such directives are not specific to any one Element within the Facility, it is up to the GOP to determine the appropriate method to achieve the desired result of the directive consistent with other applicable NERC Reliability Standards. When an RC directive specifies a particular Element or Elements at the GOP's Facility, it is the expectation and requirement that the GOP will act as directed, so long as doing so does not violate safety, equipment, or regulatory or statutory requirements or cannot be physically implemented. For example, a directive could specify

¹⁷ Note that IRO-001-3, which is adopted by the Board, was included in the proposed remand by FERC and is subject to revision as part of Project 2014-3 – Revisions to TOP and IRO Standards.

operation of a particular circuit breaker at a GOP Facility. *For these reasons, the applicability of IRO-001 does not need to be changed for dispersed power producing resources.*

4.6.2 IRO-005 — Reliability Coordination — Current Day Operations¹⁸

The purpose of this standard and its requirements as it relates to GOPs is to ensure when there is a difference in derived limits the BES is operated to the most limiting parameter. A difference in derived limits can occur on any Element and therefore any limitation of the applicability of this standard may create a reliability gap. There is no need to differentiate applicability to dispersed generation resources from any other GOP resources. *Therefore, the applicability of IRO-005 does not need to be changed for dispersed power producing resources.*

4.6.3 IRO-010 — Reliability Coordinator Data Specification and Collection

The purpose of this standard and its requirement(s) as it relates to GOs and GOPs is to ensure data and information specified by the RC is provided. As each RC area is different in nature, up to and including the tools used to ensure the reliability of the BPS, a ‘one size fits all’ approach is not appropriate. This Reliability Standard allows for the RC to specify the data and information required from the GO and/or the GOP, based on what is required to support the reliability of the BPS. *Therefore, the applicability of IRO-010 does not need to be changed for dispersed power producing resources.*

4.7 MOD

The MOD group of standards ensures consistent modeling data requirements and reporting procedures. The MOD standards provide a path for Transmission Planners (TPs) and Planning Coordinators (PCs) to reach out to entities for specific modeling information, if required. The SDT believes the existing and proposed modeling standards are sufficient for modeling dispersed power producing resources. However, due to the unique nature of dispersed power producing resources and an effort to bring consistency to the models, *the SDT believes additional guidance on the MOD standards would be beneficial and will communicate its determination to the NERC Planning Committee.*

4.7.1 MOD-010 — Steady-State Data for Transmission System Modeling and Simulation

This standard is anticipated to be retired in the near future. There is no need to differentiate dispersed generation resources from any other GOP resources as discussed in 5.7.8 regarding MOD-032. *Therefore, the applicability of MOD-010 does not need to be changed for dispersed generation resources.*

4.7.2 MOD-012 — Dynamics Data for Transmission System Modeling and Simulation

This standard is anticipated to be retired in the near future. There is no need to differentiate dispersed generation resources from any other GOP resources as discussed in 5.7.8 regarding MOD-032. *Therefore, the applicability of MOD-012 does not need to be changed for dispersed generation resources.*

¹⁸ Note that applicability to GOPs has been removed in IRO-005-4, which is adopted by the Board. However, this standard was included in the proposed remand by FERC and is subject to revision as part of Project 2014-3 – Revisions to TOP and IRO Standards.

4.7.3 MOD-024-1 — Verification of Generator Gross and Net Real Power Capability

This standard was established to ensure accurate information on generator gross and net Real Power capability is available for steady-state models used to assess BES reliability. This standard will be superseded by MOD-025-2.¹⁹ *Therefore, the applicability of MOD-024-1 does not need to be changed for dispersed generation resources.*

4.7.4 MOD-025-1 — Verification of Generator Gross and Net Reactive Power Capability

This standard was established to ensure accurate information on generator gross and net Reactive Power capability is available for steady-state models used to assess BES reliability. This standard will be superseded by MOD-025-2. *Therefore, the applicability of MOD-025-1 does not need to be changed for dispersed generation resources.*

4.7.5 MOD-025-2 — Verification and Data Reporting of Generator Real and Reactive Power Capability and Synchronous Condenser Reactive Power Capability

The purpose of MOD-025-2 is to ensure that accurate information on generator gross and net Real and Reactive Power capability is available for planning models used to assess BES reliability. This standard is appropriate for and includes specific provisions for dispersed generation resources to ensure changes in capabilities are reported. *Therefore, the SDT is further evaluating whether to revise the applicability of the standard to align the language with the revised BES definition.*

4.7.6 MOD-026 — Verification of Models and Data for Generator Excitation Control System or Plant Volt/VAR Control Functions

This standard provides for verification of models and data for voltage control functions. This standard is appropriate for dispersed generation resources. *Originally, the DGR SDT considered clarifying the applicability of the Facilities section, however, upon further review, the DGR SDT recommends no change.*

4.7.7 MOD-027 — Verification of Models and Data for Turbine/Governor and Load Control or Active Power/Frequency Control Functions

This standard was established to verify that the turbine/governor and frequency control model accurately represent generator unit Real Power response to system frequency variations. This standard is appropriate for dispersed generation resources. *Originally, the DGR SDT considered clarifying the applicability of the Facilities section, however, upon further review, the DGR SDT recommends no change.*

4.7.8 MOD-032 — Data for Power System Modeling and Analysis

The MOD-032 standard was established to ensure consistent modeling data requirements and reporting procedures for the planning horizon cases. The nature of dispersed generation resources is a challenge in modeling the steady-state and dynamic electrical properties of the individual components (e.g. individual units, collector system, interconnection components, etc.).

¹⁹ MOD-024-1 and MOD-025-1 are Board Adopted but not subject to enforcement. They are commonly followed as good utility practice.

Models for dispersed power producing resources are typically proprietary and unique for each Facility. Generic models exist for dynamic analysis that may provide sufficient accuracy in lieu of a Facility-specific model. Some sections of the MOD-032 Attachment 1 pertain to modeling individual units, which may not be feasible. Guidance should be provided to show how to best model dispersed power producing resources. Such guidance should require modeling requirements for each type of dispersed power producing resource within a Facility and aggregate model for each reasonable aggregation point. *The applicability of MOD-032 does not need to be changed for dispersed power producing resources.*

4.8 NUC

The requirements in standard NUC-001 — *Nuclear Plant Interface Coordination* individually define the applicability to Registered Entities, not to the Elements the entities own or operate. While it is unlikely any Elements that are part of a dispersed power producing resource would be subject to an agreement required by this standard, limiting the applicability of this standard could create a reliability gap and thus, there is no need to differentiate applicability to dispersed generation resources. *Therefore, the applicability of the NUC standard does not need to be changed for dispersed power producing resources.*

4.9 PER

The PER standards focus on operator personnel training. The only requirements in any of the current or future enforceable standards that apply to the GOP is requirement R6 in PER-005-2 – *Operations Personnel Training*, and it is clearly intended to apply to the individual GOP registered functional entity that controls a fleet of generating facilities, not the constituent Elements it operates. As such, there is no need to differentiate dispersed power producing resources from any other GOP resources. *Therefore, the applicability of the PER standards do not need to be changed for dispersed power producing resources.*

4.10 PRC

The PRC standards establish guidance to ensure appropriate protection is established to protect the BES.

4.10.1 PRC-001-1.1 — System Protection Coordination

Requirement R1 requires GOPs to be familiar with the purpose and limitations of Protection System schemes applied in their area. The recently approved changes to the BES definition extend the applicability of this requirement. Often this familiarity is provided to GOP personnel through training on the basic concepts of relay protection and how it is utilized. The basic relaying concepts utilized in protection on the aggregating equipment at a dispersed generation site typically will not vary significantly from the concepts used in Protection Systems on individual generating units.

Requirement R2 requires that GOPs report protective relay or equipment failures that reduce system reliability. Protective System failures occurring within a single individual generating unit at a dispersed power producing resource will not have any impact on overall system reliability and thus it should not be necessary for GOPs to report these failures to their TOP and host BA. Only failures of Protection Systems on aggregating equipment have the potential to impact BPS reliability and may require notification. When interpreted as stated above, no related changes should be required to the existing PRC-001-1 standard, as the BES definition changes do not have an impact on these requirements.

Requirement R3 requires GOPs to coordinate new protective systems. Coordinating new and changes to existing protective relay schemes should be applied to aggregating equipment protection only if a lack of coordination could cause unintended operation or non-operation of an interconnected entity's protection, thus potentially having an adverse impact to the BPS. Existing industry practice is to share/coordinate the protective relay settings on the point of interconnect (e.g. generator leads, radial generator tie-line, etc.) and potentially the main step-up transformer, but not operating (collection) buses, collection feeder, or individual generator protection schemes, as these Protection Systems do not directly coordinate with an interconnected utility's own Protection Systems. Relay protection functions such as under and overfrequency and under and overvoltage changes are independent of the interconnected utility's protective relay settings and the setting criteria are defined in PRC-024.

Requirement R5 requires GOPs to coordinate changes in generation, transmission, load, or operating conditions that could require changes in the Protection Systems of others. A GOP of a dispersed generation resource should be required to notify its TOP of changes to generation, transmission, load, or operating conditions on an aggregate Facility level.

Project 2007-06 – System Protection Coordination and Project 2014-03 – Revisions to TOP and IRO Standards are presently revising various aspects of this standard or addressing certain requirements in other standards.

For these reasons, the DGR SDT coordinated with the other SDTs currently reviewing this standard and recommended revisions to Requirement R3.1 to indicate that coordination by a GOP with their TOP and host BA of new or changes to protection systems on individual generating units of dispersed power producing resources is not required.

4.10.2 PRC-001-2 — System Protection Coordination

The concerns addressed with PRC-001-1.1b are removed in PRC-001-2, which is adopted by the Board. However, this standard was included in the proposed remand by FERC and is subject to revision as part of Project 2014-03 – Revisions to TOP and IRO Standards. This Standard version is not in effect and was withdrawn as the proposed versions of the TOP and IRO Reliability Standards included in Project 2014-3 effectively replace PRC-001-2 and other TOP standards. *For this reason, no changes are required.*

4.10.3 PRC-002-NPCC-01— Disturbance Monitoring PRC-018-1 — Disturbance Monitoring Equipment Installation and Data Reporting

Requirements related to installation of Fault/Disturbance monitoring and/or sequence of events (SOE) recording capabilities on generating units and substation equipment which meet regional specific criteria may require installation of these capabilities on the aggregating equipment at a dispersed power producing resource Facility, and also requires maintenance and periodic reporting requirements to their RRO. However, these requirements have been previously applicable to the aggregating equipment at these dispersed power producing resources, and these capabilities are not required to be installed on the individual generating units. The BES definition changes have no direct impact on applicability of these

standards to dispersed power producing resources. *Therefore, the applicability of these standards do not need to be changed for dispersed power producing resources.*²⁰

4.10.4 PRC-004-2.1a – Analysis and Mitigation of Transmission and Generation Protection System Misoperations

PRC-004-3 — Protection System Misoperation Identification and Correction

Misoperation reporting per PRC-004 is currently a requirement applied on the aggregating equipment at applicable dispersed power producing resource sites meeting BPS criteria. The continuation of this analysis and reporting on the aggregating equipment by dispersed generation resource owners can provide value to BPS reliability and should remain in place. However, based on the experience of the SDT, there is minimal impact to BPS reliability for analyzing, reporting and developing Corrective Action Plans for each individual generating unit that trips at a dispersed power producing resource site, as the tripping of one or a small number of these units has no material impact to the BPS reliability.

Additionally, reporting of Misoperations on each individual generating unit may result in substantial and unnecessary burdens on both the dispersed generation resource owner and the Regional Entities that review and track the resulting reports and Corrective Action Plan implementations. The SDT recognizes that many turbine technologies do not have the design capability of providing sufficient data for an entity to evaluate whether a Misoperation has occurred. Furthermore, dispersed power producing resources by their nature result in each individual generating unit potentially experiencing varied power system parameters (e.g., voltage, frequency, etc.) due to varied impedances and other variations in the aggregating facilities design. This limits the ability to determine whether an individual unit correctly responded to a system disturbance.

However, the SDT maintains that Misoperations occurring on the Protection Systems of individual generation resources identified under Inclusion I4 of the BES definition do not have a material impact on BES reliability when considered individually; however, the aggregate capability of these resources may impact BES reliability if a large number of the individual generation resources (aggregate nameplate rating of greater than 75 MVA) incorrectly operated or failed to operate as designed during a system event. As such, if a trip aggregating to greater than 75 MVA occurs in response to a system disturbance, the SDT proposed requiring analysis and reporting of Misoperations of individual generating units for which the root cause of the Protection System operation(s) affected an aggregate rating of greater than 75 MVA of BES Facilities. Note that the SDT selected the 75 MVA nameplate threshold for consistency and to prevent confusion.

The SDT was also concerned with the applicability of events where one or more individual units tripped and the root cause of the operations was identified as a setting error. In this case, the requirements of PRC-004 would be applicable for any individual units where identical settings were applied on the Protection Systems of like individual generation resources identified under Inclusion I4 of the BES definition.

The SDT concluded that it is not necessary under PRC-004 to analyze each individual Protection System Misoperation affecting individual generating units of a dispersed power producing resource. *The SDT*

²⁰ See NPCC CGS-005.

recommended changes to the applicability of this standard to require misoperation analysis on individual generating units at a dispersed power producing resource site, only for events affecting greater than 75MVA aggregate nameplate; the SDT determined that this will ensure that common mode failure scenarios and their potential impact on BPS reliability are appropriately addressed. The SDT's recommended changes passed industry ballot on November 6, 2014, and were approved by the Board on November 13, 2014, and are currently pending regulatory approval.

4.10.5 PRC-004-WECC-1 — Protection System and Remedial Action Scheme Misoperation

Dispersed power producing resource sites typically would not be associated with a WECC Major Transfer Path or Remedial Action Scheme (RAS), and thus would not be affected by PRC-004-WECC-1. If a site were to be involved with one of these paths or schemes, it is likely that associated protection or RAS equipment would be located on the aggregating equipment rather than the individual generating units. As such, the BES definition changes may have an impact on applicability of this standard to dispersed power producing resources. This standard should be modified to clarify the applicability for dispersed generation resources; however, this is a regional standard and not part of the SDT's scope. *Therefore, the SDT recommends that the relevant Region evaluate the standard for modification.*

4.10.6 PRC-005-1.1b — Transmission and Generation Protection System Maintenance and Testing

The SDT recognizes that PRC-005-1.1b will be phased out beginning in early 2015. Therefore, the SDT recommends only guidance on PRC-005-1.1b rather than suggesting language changes to the standard. *Therefore, the SDT does not recommend revising the applicability of this standard for dispersed generation resources, rather, the SDT provided recommendations for revisions to the applicable RSAW to NERC staff, which NERC has implemented after consultation with the Regions.*

4.10.7 PRC-005-2 — Protection System Maintenance PRC-005-3 — Protection System and Automatic Reclosing Maintenance PRC-005-4 — Protection System, Automatic Reclosing, and Sudden Pressure Relaying Maintenance

The aggregated capability of the individual generating units may in some cases contribute to the reliability of the BPS; as such, there can be reliability benefit from ensuring certain BES equipment utilized to aggregate the individual units to a common point of connection are operated and maintained as required in PRC-005. When evaluated individually, however, the generating units themselves do not have the same impact on BPS reliability as the system used to aggregate the units. The unavailability or failure of any one individual generating unit would have a negligible impact on the aggregated capability of the Facility; this would be irrespective to whether the dispersed generation resource became unavailable due to occurrence of a legitimate fault condition or due to a failure of a control system, protective element, dc supply, etc.

The protection typically utilized in these generating units includes elements which would automatically remove the individual unit from service for certain internal or external conditions, including an internal fault in the unit. These units typically are designed to provide generation output at low voltage levels, (i.e., less than 1000 V). Should these protection elements fail to remove the generating unit for this scenario, the impacts would be limited to the loss the individual generating unit and potentially the next

device upstream in the collection system of the dispersed power producing resource. However, this would still only result in the loss of a portion of the aggregated capability of the Facility, which would be equally likely to occur due to a scenario in which a fault occurs on the collection system.

Internal faults on the low voltage system of these generating units would not be discernible on the interconnected transmission systems, as this is similar to a fault occurring on a typical utility distribution system fed from a substation designed to serve customer load. It is important to note that the collection system equipment (e.g., breakers, relays, etc.) used to aggregate the individual units may be relied upon to clear the fault condition in both of the above scenarios, which further justifies ensuring portions of the BES collection equipment is maintained appropriately.

**4.10.8 For this reason, activities such as Protection System maintenance on each individual generating unit at a dispersed generation Facility would not provide any additional reliability benefits to the BPS, but Protection System maintenance on facilities where generation aggregates to 75 MVA or more would. The SDT proposes that the scope of PRC-005 be limited to include only the protection systems that operate at a point of aggregation above 75 MVA nameplate rating. If the aggregation point occurs at a component in the collection system, then the protection systems associated with this component would be in scope. *The SDT has recommended changes to the Applicability Section (Facilities) of PRC-005-2, -3, and -4 to indicate that maintenance activities should only apply on the aggregating equipment at or above the point where the aggregation exceeds 75 MVA. The SDT's recommended applicability changes to PRC-005-2 and PRC-005-3 were approved by the Board on November 13, 2014. The SDT's recommended applicability changes to PRC-005-4 were posted for an initial ballot period that ends on January 22, 2014.* PRC-006-NPCC-1 — Automatic Underfrequency Load Shedding
PRC-006-SERC -1 — Automatic Underfrequency Load Shedding Requirements**

The regional specific PRC-006 standards deviate from the PRC-006-1 standard in that they have specific requirements for GOs. In particular, the NPCC version requires that GOs set their underfrequency tripping to meet certain criteria to ensure reliability of the BPS. Typically a dispersed generation resource site may have underfrequency protection on both the aggregating equipment (i.e., collection buses or feeders) as well as the individual generating units. Were this standard only to apply to aggregating equipment, the net impact to the BPS should a system disturbance occur may still result in a loss of significant generating capacity should each of the individual generating units trip for the event. Therefore it may be appropriate to include the individual generating units at a dispersed generation resource site as subject to this standard. The standard could be interpreted this way as written, but further clarification in the standard language may be considered. While this standard may need to be modified to clarify the applicability for dispersed generation resources, this is a regional standard and not part of the SDT's scope. *Therefore, the SDT recommends that the relevant Region evaluate the standard for modification.*

The SERC version of PRC-006 requires GOs to provide, upon request, certain under and overfrequency related set points and other related capabilities of the site relative to system disturbances. It may be appropriate to include the capabilities of the individual generating units at a dispersed generation resource site when providing this information; however, it may be sufficient to provide only the capabilities of a

single sample unit within a site as these units are typically set identically. This would be in addition to any related capabilities or limitations of the aggregating equipment as well. This may be accomplished by providing clarifications in the requirements sections. While this standard may need to be modified to clarify the applicability for dispersed power producing resources, this is a regional standard and not part of the SDT's scope. *Therefore, the SDT recommends that the relevant Region evaluate the standard for modification.*

4.10.9 PRC-015 — Special Protection System Data and Documentation
PRC-016 — Special Protection System Misoperations
PRC-017 — Special Protection System Maintenance and Testing

Relatively few dispersed power producing resources own or operate Special Protection Systems (SPSs); however, they do exist and therefore need to be evaluated for applicability based on the revised BES definition. The vast majority of these SPSs involve the aggregating equipment (transformers, collection breakers, etc.) and not the individual generating units. The SPSs are installed to protect the reliability of the BPS, and as such the aggregated response of the site (e.g., reduction in output, complete disconnection from the BES, etc.) is critical, not the response of individual generating units. *Therefore, the applicability of these standards does not need to be changed for dispersed power producing resources.*

4.10.10 PRC-019-1 — Coordination of Generating Unit or Plant Capabilities, Voltage Regulating Controls, and Protection

Dispersed power producing resources typically utilize a site level voltage control scheme that directs the individual generating units to adjust their output to meet the voltage requirements at an aggregate Facility level. In these cases the individual generating units will simply no longer respond once they are “maxed out” in providing voltage or reactive changes, but also need to be properly coordinated with protection trip settings on the aggregating equipment to mitigate risk of tripping in this scenario. For those facilities that solely regulate voltage at the individual unit, these facilities also need to consider the Protection Systems at the individual units and their compatibility with the reactive and voltage limitations of the units. The applicability in PRC-019-1 (section 4.2.3) includes a “Generating plant/Facility consisting of one or more units that are connected to the Bulk Electric System at a common bus with total generation greater than 75 MVA (gross aggregate nameplate rating).” *Therefore, the DGR SDT revised the Facilities section of the standard to clarify that facilities which solely regulate voltage at the individual generating unit are subject to this standard's requirements. The SDT's recommended applicability changes to PRC-019-1 were posted for an initial comment and ballot period scheduled to close December 22, 2014.*

4.10.11 PRC-023— Transmission Relay Loadability

Dispersed power producing resources in some cases contain facilities and Protection Systems that meet the criteria described in the Applicability Section (e.g., load responsive phase Protection System on transmission lines operated at 200 kV or above); however, in the majority of cases these lines are radially connected to the remainder of the BES and are excluded from the standard requirements of PRC-023-3. While certain entities with dispersed power producing resources are required to meet the requirements of PRC-023 on components of their aggregating equipment (e.g., main step-up transformers, interconnecting transmission lines) the standard is not applicable to the individual generating units, as the individual generating units are addressed in PRC-025. The BES definition changes have no direct impact on the

applicability of this standard to dispersed power producing resources. *Therefore, the applicability of this standard does not need to be changed for dispersed power producing resources.*

4.10.12 PRC-024— Generator Frequency and Voltage Protective Relay Settings

If the individual generating units at a dispersed power producing resource were excluded from this requirement, it is possible large portions or perhaps the entire output of a dispersed power producing resource site may be lost during certain system disturbances, negatively impacting BES reliability. The SDT has determined it is appropriate to require that Protection System settings applied on both the individual generating units and aggregating equipment (including any Protection Systems applied on non-BES portions of the aggregating equipment), are set within the “no-trip zone” referenced in the requirements to maintain reliability of the BES. However, for the purpose of compliance evidence, the SDT believes it should be sufficient for an entity to provide evidence for a single sample generating unit within a site rather than providing documentation for each individual unit, providing the entity used that methodology to set its protection systems for all the units, rather than providing documentation for each individual unit. This would be in addition to any Protection System settings evidence for the aggregating equipment. *The SDT therefore recommended changes to the standard requirements to ensure these requirements are applied to the individual power producing resources as well as all equipment, potentially including non-BES equipment, from the individual power producing resource up to the point of interconnection and communicated compliance evidence requirement considerations to NERC staff for RSAW development. The SDT’s recommended applicability changes to PRC-024 were posted for an initial comment and ballot period scheduled to close December 22, 2014.*

4.10.13 PRC-025— Generator Relay Loadability

The Protection System utilized on individual generating units at a dispersed power producing Facility may include load-responsive protective relays and thus would be subject to the settings requirements listed in this standard. Were this standard only to apply to aggregating equipment, the net impact to the BPS should a system disturbance occur, may be a loss of significant generating capacity should each of the individual generating units trip for the event. The SDT has determined it is appropriate to require that Protection System settings applied on both the individual generating units at a dispersed power producing resource site as applicable to this standard. However, for the purpose of compliance evidence, the SDT believes it should be sufficient for an entity to provide evidence for a single sample generating unit within a site rather than providing documentation for each individual unit, providing the entity used that methodology to set its protection systems for all the units, rather than providing documentation for each individual unit. This would be in addition to any Protection System settings evidence for the aggregating equipment. As such the SDT recommends the RSAW be modified as stated above. *The SDT recommended no changes to the standard; however, the DGR SDT communicated compliance evidence requirement considerations to NERC staff for RSAW development.*

4.11 TOP

The TOP standards provide TOPs their authority. There are four TOP standards that apply directly to GO and GOP entities. The TOP standards as they relate to GOs/GOPs ensure RCs and TOPs can issue directives to the GOP, and the GOP follows such directives. They also ensure GOPs render all available

emergency assistance as requested. Finally, they require GO/GOPs to coordinate their operations and outages and provide data and information to the BA and TOP. No TOP standard refers to the interaction of a host BA, TOP, or RC with individual BES Elements.

4.11.1 TOP-001-1a — Reliability Responsibilities and Authorities

This standard as it applies to GOPs is reviewed at the requirement level, with only one change recommended.

4.11.1.1 Requirement R3

The purpose of requirement R3 as it relates to GOPs is to ensure the RC and TOP reliability directives are complied with so long as they do not violate safety, equipment, or regulatory or statutory requirements. If a GOP is unable to follow a RC or TOP reliability directive they are to inform the RC or TOP immediately of such. The requirement is applicable to the registered functional entity, not the constituent Elements it operates. *Therefore, there is no need to differentiate applicability to dispersed power producing resources from any other GOP resources, and no change to this requirement is needed.*

4.11.1.2 Requirement R6

The purpose of requirement R6 as it relates to GOPs is to ensure all available emergency assistance to others as requested, unless such actions would violate safety, equipment, or regulatory or statutory requirements. The requirement is applicable to the registered functional entity, not the constituent Elements it operates. *Therefore, there is no need to differentiate applicability to dispersed power producing resources from any other GOP resources, and no change to this requirement is needed.*

4.11.1.3 Requirement R7

The purpose of requirement R7 as it relates to GOPs is to ensure BES facilities are not removed from service without proper notification and coordination with the TOP and, when time does not permit such prior notification and coordination, notification and coordination shall occur as soon as reasonably possible. This is required to avoid burdens on neighboring systems. It should be noted that the purpose of this standard is to keep the TOP informed of all generating Facility capabilities in case of an emergency. It is assumed that required notification and coordination from the GOP to the TOP would be done in real-time and through verbal communication media. The concern here is how to apply this to a dispersed power producing resource Facility. The SDT recommends that the GOP report at the aggregate Facility level to the TOP any generator outage above 20 MVA for dispersed power producing resource facilities. The justification is based on the following:

- This is consistent with Inclusion I2 of the revised BES definition, which addresses only generating units greater than 20 MVA.
- TOP-002-2.1b Requirement R14 requires real-time notification of changes in Real Power capabilities, planned and unplanned. Setting the threshold at 20 MVA would address routine maintenance on a small portion of the Facility (e.g., 2% of the generators are out of service on any given day) and individual generating units going into a failure. Otherwise, coordinating each individual generating unit outage would burden the TOP without providing an increase in reliability to the interconnected BPS.

Dispersed power producing resource outages should be reported as X MW out of Y MW are available. *Therefore, the SDT recommends that a modification to the applicability of this requirement is necessary for dispersed power producing resources for generator outages greater than 20 MVA.*

4.11.2 TOP-001-3— Transmission Operations²¹

The purpose of this standard as it relates to GOPs is to ensure TOP directives are complied with so long as they do not violate safety, equipment, or regulatory or statutory requirements. If a GOP is unable to follow a TOP directive they are to inform the TOP immediately of such. It directs the TOP to issue directives and as such the TOP may provide special requirements for dispersed power producing resources for its unique capabilities. *The SDT recommends that Project 2014-3 provide direction for a dispersed power producing resource to be only reported at the aggregate facility level. If TOP-001-1a R7 is reintroduced, then the recommendation provided above should be included in their efforts.*

4.11.3 TOP-002-2.1b — Normal Operations Planning²²

This TOP standard has five requirements applied to GOPs. Several modifications are recommended below, and the SDT recommends that the most effective and efficient way to accomplish this is through modification of the Applicability Section of this standard.

4.11.3.1 Requirement R3

The purpose of requirement R3 as it relates to GOPs is to ensure a GOP's current day, next-day and seasonal operations are coordinated with its host BAs and TSP. This requirement relates to planned operations at a generator and does not include unplanned operations such as forced or emergency operations. The SDT recommends that this requirement be applied at the aggregate Facility level for dispersed power producing resources. For example, forecasting available MW at the aggregated Facility level is currently one method used. The SDT does not see any reliability gap in that would prompt this team to apply R3 to any point less than the dispersed power resource aggregated Facility level. *The SDT has not found or been made aware of a reliability gap that would prompt this team to apply R3 to any point less than the dispersed power resource aggregated Facility level and recommends such modification to the applicability of this requirement.*

4.11.3.2 Requirement R13

The purpose of requirement R13 as it relates to GOPs is to ensure Real Power and Reactive Power capabilities are verified as requested by the BA and TOP. The SDT believes a modification to the applicability of this requirement is necessary for dispersed power producing resources. The SDT is recommending that this requirement be applied at the aggregate Facility level for dispersed power producing resources for the following reasons:

- Due to the nature, amount of individual generators at a dispersed power producing resource, internal Real Power losses, and natural inductance and capacitance of dispersed power resource

²¹ Note that TOP-001-2 was adopted by the Board and remanded by FERC. TOP-001-2 is currently under revision as part of Project 2014-03 – Revisions to TOP and IRO Standards, and was posted for additional ballot period that is scheduled to close January 7, 2015 as TOP-001-3.

²² The GOP applicability is removed in TOP-002-3, which was adopted by the Board. However, TOP-002-3 was included in the proposed remand by FERC and is subject to revision as part of Project 2014-3 – Revisions to TOP and IRO Standards.

system connected in series, verification of real and reactive capabilities should be conducted at the dispersed power producing resource aggregate Facility level. Performing verification in this manner will provide an actual net real and reactive capability, which would be seen by both the BA and TOP. In addition, performing verification in this manner is also consistent with operating agreements such as an interconnection agreement, which the dispersed power resource has with the TOP and BA.

- MOD-025-2 also provides that verification for any generator <20MVA may be completed on an individual unit basis or as a “group.” Reporting capability at the aggregated Facility level is consistent with the MOD-025-2 provision for group verification.

The SDT recommends a modification to the applicability of this requirement at the aggregated Facility level for dispersed power producing resources.

4.11.3.3 Requirement R14

The purpose of requirement R14 as it relates to GOPs is to ensure BAs and TOPs are notified of changes in real output capabilities without any intentional time delay. It should be noted that the purpose of this requirement is to address unplanned changes in real output capabilities. It is assumed the required notification and coordination from the GOP to the BA and TOP would be done in real-time and through verbal communication media. The concern here is how to apply this to dispersed power producing resources. The SDT recommends that the GOP notify at the aggregate Facility level to the TOP any unplanned changes in real output capabilities above 20 MVA. The justification is based on the following:

- This is consistent with Inclusion I2 of the revised BES definition which includes generating units greater than 20MVA; and
- TOP-002-2.1b R14 requires real-time notification of changes in Real Power capabilities, planned and unplanned. Setting the threshold at 20 MVA would address routine maintenance on a small portion of the Facility (e.g. 2% of the generators are out of service on any given day) and individual generating units going into a failure. Otherwise, coordinating each individual generating unit outage would burden the TOP without providing an increase in reliability to the interconnected BPS.

Dispersed generation resources changes in real output capabilities should be reported as X MW out of Y MW are available. *The SDT recommends that a modification to the applicability of this requirement is necessary for dispersed power producing resources for unplanned outages greater than 20 MVA.*

4.11.3.4 Requirement R15

The purpose of requirement R15 as it relates to GOPs is to ensure BAs and TOPs are provided a forecast (e.g., seven day) of expected Real Power. The SDT believes this requirement as requested by the BA or TOP is being applied at the aggregate Facility level for dispersed power producing resources.

Based on the SDT’s experience, expected Real Power forecasts (e.g. 5 or 7 forecast) for a dispersed power producing resource has been traditionally coordinated with the BA and TOP at the aggregate Facility level for dispersed power producing resources. *Therefore, the SDT recommends that R15 be applied at the aggregate Facility level for dispersed power resources and as such, modification to the applicability of this requirement is necessary.*

4.11.3.5 Requirement R18

The purpose of requirement R18 as it relates to a GOP is to ensure uniform line identifiers are used when referring to transmission facilities of an interconnected network. The standard applies to transmission facilities of an interconnected network, which would not apply to any Elements within the dispersed generation Facility. There is no need to differentiate applicability to dispersed generation resources from any other GOP resources. *Therefore, the applicability of this requirement does not need to be changed for dispersed generation resources.*

4.11.4 TOP-003-1— Planned Outage Coordination

This TOP Standard has three requirements applied to GOPs. Modification to one of these requirements is recommended.

4.11.4.1 Requirement R1

The purpose of requirement R1 as it relates to GOPs is to ensure TOPs are provided planned outage information on a daily basis for any scheduled generator outage >50MW for the next day. *Therefore, the applicability of this requirement does not need to be changed for dispersed generation resources.*

4.11.4.2 Requirement R2

The purpose of requirement R2 as it relates to GOPs is to ensure all voltage regulating equipment scheduled outages are planned and coordinated with affected BAs and TOPs. A modification to the applicability of this requirement is necessary for dispersed power producing resources. The SDT recommends that this requirement be applied at the aggregate Facility level for dispersed power producing resources.

Based on the SDT's experience, scheduled outages of voltage regulating equipment at a dispersed power producing resource has been traditionally provided to the BA and TOP at the aggregate Facility level for dispersed power producing resources. Outages of voltage regulating equipment at a dispersed power producing resource are coordinated typically as a reduction in Reactive Power capabilities, specifying whether it is inductive, capacitive or both. Additionally, automatic voltage regulators that do not necessarily provide Reactive Power, but direct the actions of equipment that do supply Reactive Power, are typically coordinated at the aggregate Facility level as they usually are the master controller for all voltage regulating equipment at the Facility. A key aspect of the SDT project is to maintain the status quo, if it is determined not to cause a reliability gap. *The SDT has not found or been made aware of a reliability gap, which would prompt this team to apply R2 to any point less than the dispersed power producing resource aggregated Facility level and as such, determined a modification to the applicability of this requirement is necessary for dispersed power producing resources.*

4.11.4.3 Requirement R3

The purpose of requirement R3 as it relates to GOPs is to ensure scheduled outages of telemetering and control equipment and associated communication channels are planned and coordinated among BAs and TOPs. Based on the SDT technical expertise, scheduled outages of telemetering and control equipment and associated communication channels at a dispersed power producing resource have been traditionally provided to the BA and TOP at the aggregate Facility level for dispersed power producing resources. In addition, only scheduled outages of telemetering and control equipment and associated communication

channels that can affect the BA and TOP are coordinated with the BA and TOP. *Therefore, the applicability of this requirement does not need to be changed for dispersed power producing resources.*

4.11.5 TOP-006 — Monitoring System Conditions

The purpose of this standard as it relates to GOPs is to ensure BAs and TOPs know the status of all generation resources available for use as informed by the GOP. It should also be noted that the purpose of this standard is to ensure critical reliability parameters are monitored in real-time. It then can be extrapolated that the requirement, “GOP shall inform...” is done by sending dispersed power producing resource telemetry in real-time and through a digital communication medium, such as an ICCP link or RTU. The SDT feels a modification to the applicability of this requirement is necessary for dispersed power producing resources. The SDT is recommending that this requirement be applied at the aggregate Facility level for dispersed power producing resources for the following reasons:

- This is consistent with Inclusion I2 of the revised BES definition, which includes generating units greater than 20MVA. If removing <20MVA would cause a burden to the BPS, then the threshold for inclusion in the BES would have been less than 20MVA;
- Routine maintenance is frequently completed on a small portion of the entire Facility (e.g. 2% of the generators are out of service on any given day) such as to not have a significant impact to the output capability of the Facility. Additionally, it is not uncommon to have individual generating units at a dispersed power producing resource to go into a failure mode due to internal factors of the equipment, such as hydraulic fluid pressure tolerances, gearbox bearing thermal tolerances, etc. As such, coordinating each individual generating unit outage would burden the TOP without providing an increase in reliability to the interconnected BPS; and
- As this standard requires real-time monitoring, this is most likely completed through a digital medium such as an ICCP link or RTU. The data that a dispersed power resource provides to the BA and TOP in real-time should include the aggregate active power output of the Facility, among other telemetry points. These data specifications are usually outlined in interconnection agreements among the parties.

Based on the SDT technical expertise, BAs and TOPs are informed by the GOP of all generation resources available at the dispersed power producing resource at the aggregate Facility level. Traditionally the dispersed power producing resources are providing the BA and TOP, at minimum, the following telemetry points in real-time: aggregate Real Power, aggregate Reactive Power and main high-side circuit breaker status. A key aspect of the SDT project is to maintain the status quo, if it is determined not to cause a reliability gap. *The SDT has not found or been made aware of a reliability gap, which would prompt this team to apply these requirement to any point less than where the dispersed power producing resource aggregates and as in such, recommends a modification to the applicability of this requirement is necessary for dispersed power producing resources.*

4.12 TPL

At the time of this paper, these standards do not affect GOs or GOPs directly. Input from GO or GOP entities is provided to transmission planning entities through the MOD standards. *Therefore, the applicability of the TPL standards does not need to be changed for dispersed power producing resources.*

4.13 VAR

The VAR standards exist to ensure that voltage levels, reactive flows, and reactive resources are monitored, controlled, and maintained. There are two VAR Standards that apply to GOs and/or GOPs. The voltage and/or reactive schedule provided by TOPs is specified to be at the point of interconnection or the point specified in the interconnection agreement.

4.13.1 VAR-001 — Voltage and Reactive Control (WECC Regional Variance)

The purpose of this standard as it relates to GOPs in WECC is to ensure a generator voltage schedule is issued that is appropriate for the type of generator(s) at a specific Facility. Additionally, it requires GOPs to have a methodology for how the voltage schedule is met taking into account the type of equipment used to maintain the voltage schedule. Based on the SDT technical expertise, voltage control and voltage schedule adherence for dispersed power producing resource occurs at the aggregate Facility level. There is no need to differentiate dispersed generation resources from any other GOP resources. *Therefore, the applicability of VAR-001 does not need to be changed for dispersed generation resources.*

4.13.2 VAR-002-2b — Generator Operation for Maintaining Network Voltage Schedules VAR-002-3 — Generator Operation for Maintaining Network Voltage Schedules

The purpose of these standards as they relate to GOs and GOPs is to ensure generators operate in automatic voltage control mode as required by the TOP voltage or reactive power schedule provided to ensure voltage levels, reactive flows, and reactive resources are maintained within applicable Facility Ratings to protect equipment and reliability of the Interconnection. Based on the SDT technical expertise, voltage control and voltage schedule adherence for dispersed power producing resource occurs at the aggregate Facility level and such guidance should be provided.

In addition, the voltage-controlling equipment and the methodology to ensure the Facility has an automatic and dynamic response to ensure the TOP's instructions are maintained can be very different for each Facility. It is implied in VAR-001-3 that each TOP should understand capabilities of the generation Facility and the requirements of the transmission system to ensure a mutually agreeable solution/schedule is used.

**4.13.3 VAR-002-2b — Requirement R3.1
VAR-002-3 — Requirement R4**

**4.13.4 The purpose of these requirements is to ensure that a GOP notifies the TOP, within 30 minutes, any status and capability changes of any generator Reactive Power resource, including automatic voltage regulator, power system stabilizer or alternative voltage controlling device. Based on the experience of the SDT, status and capability changes is traditionally coordinated at the aggregate Facility level point of interconnection. Therefore, the SDT has recommended changes to the standard to clarify the applicability of VAR-002-2b R3.1 and VAR-002-3 R4 for dispersed power producing resources. These changes were successfully balloted in VAR-002-4 on November 6, 2014, and approved by the Board on November 13, 2014. VAR-002-2b — Requirement R4
VAR-002-3 — Requirement R5**

The purpose of these requirements is to ensure that Transmission Operators and Transmission Planners have appropriate information and provide guidance to the GOP in regards to Generator Operator's transformers to ensure voltage levels, reactive flows, and reactive resources are maintained within applicable Facility Ratings to protect equipment and reliability of the Interconnection. Based on the experience of the SDT dispersed power producing resources individual generator transformers have traditionally been excluded from the requirements of VAR-002-2b R4 and VAR-002-3 R5, as they are not used to improve voltage performance on the Interconnection. As such, applicability should be limited to transformers with at least one winding at a voltage of 100kV or above. *Therefore, the SDT has recommended changes to the standard to clarify the applicability of VAR-002-2b R4 and VAR-002-3 R5 for dispersed generation resources. These changes were successfully balloted in VAR-002-4 on November 6, 2014, and approved by the Board on November 13, 2014.*

4.14 CIP

4.14.1 CIP v5

The CIP standards are still under revision in Project 2014-02. The DGR SDT and the CIP SDT continue to coordinate revisions to the CIP standards, and will update this section to reflect the outcome of that effort at the appropriate time.

The CIP standards ensure physical and cyber security for BES Cyber Assets and BES Cyber Systems critical to the reliability and security of the BES. CIP-002 identifies critical assets or systems of a Facility, while CIP-003 to CIP-011 depend on the outcome of the CIP-002 assessment to determine applicability.

During the Project 2014-02 CIP Version 5 Revisions SDT first comment period, it received comments to modify CIP-003-6 in the Applicability Section. The CIP SDT made drastic modifications to the second posting of CIP-003-6 to take into accounts all of the comments received, which was posted for an additional 45-day comment and ballot period on September 3, 2014.

At its September meeting, the DGR SDT had a focused discussion with the CIP SDT surrounding the technical nature of the dispersed power producing resources and how it relates to the CIP standards. The coordinating effort resulted in discussions of the revised CIP-003-6. As for that posted revised standard,

the CIP SDT took the approach of including an Attachment 1 for Responsible Entities. The Attachment 1 requires elements to be developed in Responsible Entities' cyber security plan(s) for assets containing low impact BES Cyber Systems. The elements in CIP-003-6, Attachment 1 allow flexibility for the controls to be established for each of the main four elements below. The CIP SDT encourages observers of the DGR SDT to review the Attachment 1 in detail. Here is some information regarding the attachment.

Element 1: Security Awareness

The intent of the security awareness program is for entities to reinforce good cyber security practices with their personnel at least once every 15 calendar months. It is up to the entity as to the topics and how it schedules these topics. The Responsible Entity should be able to produce the awareness material that was delivered and the delivery method(s) (posters, emails, topics at staff meetings, etc.) that were used. The SDT does not intend that the Responsible Entity must maintain lists of recipients and track the reception of the awareness material by personnel.

Element 2: Physical Security

The Responsible Entity has flexibility in the controls used to restrict physical access to low impact BES Cyber Systems at a BES asset using one or a combination of access controls, monitoring controls, or other operational, procedural, or technical physical security controls. Entities may utilize perimeter controls (e.g., fences with locked gates, guards, site access policies, etc.) and/or more granular areas of physical access control in areas where low impact BES Cyber Systems are located, such as control rooms or control houses. User authorization programs and lists of authorized users are not required.

Element 3: Electronic Access Controls

Where Low Impact External Routable Connectivity (LERC) or Dial-up Connectivity exists, the Responsible Entity must document and implement controls that include the LERC and Dial-up Connectivity to the BES asset such that the low impact BES Cyber Systems located at the BES asset are protected. Two glossary terms are included in order to help clarify and simplify the language in Attachment 1. The SDT's intent in creating these terms is to avoid confusion with the similar concepts and requirements (ESP, EAP, ERC, EACMS) needed for high and medium impact BES Cyber Systems by utilizing separate terms that apply only to assets containing low impact BES Cyber Systems.

Element 4: Cyber Security Incident Response

The entity should have one or more documented cyber security incident response plans that include each of the topics listed. For assets that do not have LERC, it is not the intent to increase their risk by increasing the level of connectivity in order to have real-time monitoring. The intent is if in the normal course of business suspicious activities are noted at an asset containing low impact BES Cyber Systems, there is a cyber security incident response plan that will guide the entity through responding to the incident and reporting the incident if it rises to the level of a Reportable Cyber Security Incident.

Therefore, the DGR SDT recommends that no changes be made to proposed CIP-003-6. CIP-002-5.1 needs to remain as is because entities must go through the process for identifying and categorizing its BES Cyber Systems and their associated BES Cyber Assets. The controls put in place for proposed CIP-003-6, Attachment 1, are not burdensome, are realistic and achievable, and does not express undue

compliance burden. In conclusion, the DGR SDT states that the reliability objective of these controls are adequate and the applicability of CIP-003-6 should not be modified.

The SDT states that the CIP Version 5 Revisions SDT should consider developing guidance documentation around the following areas:

- Low Impact BES Cyber Systems that must comply with a limited number of requirements, all located in CIP-003-5. The only technical requirement is R2, which will be modified during the current drafting activity to add clarity to the requirement. The SDT notes that the CIP Version 5 Revisions SDT should consider developing guidance around how this requirement relates to dispersed generation;
- Any programmable logic device that has the capability to shut down the plant within 15 minutes; and
- Remote access from third party entities into the SCADA systems that control the aggregate capacity of a Facility should be assessed to determine if there is a need of any additional cyber security policies.

The SDT intends to recommend guidance for those companies that only operate their turbines from one central location. Individual Elements lumped into a BES Cyber System should be addressed. When operations are on a turbine-by-turbine basis, the SDT believes there should not be rigid controls in place. The inability to “swim upstream” should be addressed as well. Further, the guidance intends to address when manufacturers operate or have control of the SCADA environment to conduct troubleshooting and other tasks, and ensure that proper security is in place.

NERC staff has committed to facilitate communication between the SDT and the CIP Version 5 Revisions SDT as appropriate to ensure alignment and to develop language for guidance, coordinated between the two SDTs. *Therefore, the applicability of CIP standards does not need to be changed for dispersed generation resources.*

Appendix A: List of Standards

Appendix B: List of Standards Recommended for Further Review

Draft White Paper

Proposed Revisions to the Applicability of NERC Reliability Standards NERC Standards Applicability to Dispersed Generation Resources

Project 2014-01 Standards Applicability for Dispersed
Generation Resources Standard Drafting Team

~~October 5~~December 11, 2014

Table of Contents

1	EXECUTIVE SUMMARY	3
2	PURPOSE	5
3	BACKGROUND	6
3.1	BES DEFINITION	6
3.2	DISPERSED GENERATION RESOURCES	7
3.3	DRAFTING TEAM EFFORTS	9
4	TECHNICAL DISCUSSION	11
4.1	BAL	11
4.2	COM	12
4.3	EOP	12
4.4	FAC	12
4.5	INT	18
4.6	IRO	19
4.7	MOD	20
4.8	NUC	21
4.9	PER	22
4.10	PRC	22
4.11	TOP	28
4.12	TPL	34
4.13	VAR	34
4.14	CIP	35
	APPENDIX A: LIST OF STANDARDS	38
	APPENDIX B: LIST OF STANDARDS RECOMMENDED FOR FURTHER REVIEW	39

1 Executive Summary

The purpose of this ~~white~~ ~~White paper~~ ~~Paper~~ is to provide background and technical rationale for proposed revisions to the applicability of several North American Electric Reliability Corporation (NERC) Reliability Standards, and in some cases the standard requirements. The goal of the NERC Project 2014-01 Standards Applicability for Dispersed ~~Power Producing~~ ~~Generation~~ Resources¹ standard drafting team (SDT) is to ensure that the Generator Owners (GOs) and Generator Operators (GOPs) of dispersed power producing resources are appropriately assigned responsibility for requirements that impact the reliability of the Bulk Power System (BPS), as the characteristics of operating dispersed power producing resources can be unique. In light of the revised Bulk Electric System (BES) definition approved by the Federal Energy Regulatory Authority (FERC) in 2014², the intent of this effort is generally to maintain the status quo for applicability of the standards as they have been applied over time with respect to dispersed power producing resources where the status quo does not create a reliability gap.

The SDT reviewed all standards that apply to GOs and GOPs³ and determined how each standard requirement should be appropriately applied to dispersed power producing resources, categorized as follows:

- The existing standard language was appropriate when applied to dispersed power producing resources and does not need to be addressed;
- The existing standard language was appropriate when applied to dispersed power producing resources but additional NERC guidance documentation is needed to clarify how to implement the requirements for dispersed power producing resources; and
- The existing standard language needs to be modified in order to account for the unique characteristics of dispersed power producing resources. This could be accomplished through the ~~applicability~~ ~~Applicability section~~ ~~Section~~ of the standard in most cases or, if required, through narrowly ~~tailored~~ changes to the individual requirements.

From this review, ~~the SDT determined that there are~~ three (3) ~~Reliability S~~ ~~standards-~~ ~~required in which the SDT feels~~ immediate attention ~~is required to~~ ~~clarify the applicability of the Reliability Standards to dispersed power producing resources for the benefit~~ ~~provide direction of to~~ industry stakeholders ~~as soon as feasible regarding how to appropriately direct compliance related preparations~~. These standards ~~include~~ ~~are~~:

- PRC-004 (relevant versions)⁴;
- PRC-005 (relevant versions)⁵; and

¹ Although the BES definition uses the term “dispersed power producing resources,” the SAR and the SDT also use the term “dispersed generation resources.” For the purposes of this paper, these terms are interchangeable.

² Glossary of Terms Used in NERC Reliability Standards, updated March 12, 2014.

³ See Appendix A.

⁴ Reliability Standard PRC-004 ~~is currently being~~ ~~was~~ revised as part of Project 2010-05.1 Protection Systems: Misoperations.

⁵ Reliability Standard PRC-005 ~~is currently being~~ ~~was~~ revised as part of Project 2007-17.3 – Protection System Maintenance and Testing – Phase 3.

- VAR-002 (relevant versions)⁶.

However, ~~the~~ SDT ~~has~~ recognized that many other standards⁷ required further review ~~by the SDT~~ to determine the necessity and the type of clarification or guidance for the applicability to dispersed power producing resources. This necessity is based on how each standard requirement, as written, would apply to dispersed power producing resources and the individual generating units at these facilities, considering the ~~recently approved~~ now currently-enforced BES definition. The proposed resolutions target the applicability of the standard ~~noted in the language of the applicability section~~ or ~~specifically~~ target specific individual requirements. There are additional methods to ensure consistent applicability throughout the Regions, including having guidance issued by NERC through Reliability Standard Audit Worksheet (RSAW) language revisions. These tools, among others, have been be considered and employed by the SDT throughout the work-drafting effort.

The ~~technical section of this White Paper~~ ~~includes insight from the SDT review~~; includes:ing 1) description of the history of standards applicability to dispersed power producing resources; 2) identification of ~~any unique~~ circumstances and practices that are unique to ~~for~~ dispersed power producing resources ~~and current practices;~~ and 3) as well as the SDT's categorization and determination of the priority to address standards, supported by corresponding technical justification.

~~This white paper is a living document.~~ It is the intent of the SDT to modify this document over the course of this project to document the SDT's rationale and technical justification for each standard until the work of the SDT is complete. The SDT considers the sections of the ~~w~~White ~~p~~Paper that address the high-priority standards to be in final draft form. The SDT may provide further revisions to the remainder of the ~~w~~White ~~p~~Paper.

⁶ Reliability Standard VAR-002 was ~~is~~ currently being revised as part of Project 2013-04 – Voltage and Reactive Control.

⁷ See Appendix B.

2 Purpose

The purpose of this ~~white paper~~ White Paper is to provide background and technical rationale for proposed revisions to the applicability of several Reliability Standards⁸ or requirements that apply to GOs and/or GOPs. The goal of the proposed applicability changes is to ~~ensure that~~ provide the GOs and GOPs of dispersed generation resources ~~with~~ have clarity ~~regarding~~ as to their responsibility for requirements that impact the reliability of the BPS, as the characteristics of operating dispersed generation can be unique. ~~The SDT seeks to provide is~~ clarity through the method most appropriate for each standard, such as will be accomplished through revised by: (1) revising applicability language in the standard;s; (2) revising language in the requirements to address changes to applicability; (3) recommend~~ing~~ed changes to the RSAW associated with the standard;; or (4) recommend~~ing~~ations for a reliability guideline or reference document.

This document ~~describes~~ lays out a common understanding of the design, ~~and~~ operational characteristics, ~~and unique features~~ of dispersed ~~power producing generation~~ resources, ~~highlighting the unique features of dispersed generation resources~~. The recommendations identified in this document consider the ~~purpose~~ Purpose and ~~time~~ Time horizon ~~Horizon~~ of the standards and requirements, as well as the avoidance of applying requirements in a manner that has no significant effect on reliability.⁹ This document provides justification of, and proposes revisions to, the applicability of the Reliability Standards and requirements, both existing and in development, and should be considered guidance for future standard development efforts. However, please note that the recommendations provided in this paper are subject to ~~comment~~ and further review and revision.

Note that while this ~~paper~~ White Paper may provide examples of dispersed power producing generation resources, the concepts presented are not specific to any one technology. The ~~Dispersed Generation Resources~~ SDT in general has referenced the BES Reference Document, which also refers to “dispersed power producing resources.” Although the BES definition uses the term “dispersed power producing resources,” the Standard Authorization Request (SAR) and the SDT also use the term “dispersed generation resources.” For the purposes of this paper, these terms are interchangeable.

⁸ Note that “Reliability Standard” is defined in the NERC Glossary as “approved by FERC,” but that the ~~Dispersed Generation Resources~~ SDT reviewed approved ~~and unapproved~~ standards, as well as revisions to standards proposed in other projects.

⁹ *North American Electric Reliability Corporation*, 138 FERC ¶ 61,193 at P 81 (2012).

3 Background

~~By submitting Industry stakeholders submitted~~ a SAR to the NERC Standards Committee, ~~industry stakeholders request~~ing ~~ed~~ that the applicability of Reliability Standards or the requirements of Reliability Standards be revised to ensure that the Reliability Standards are not imposing requirements on dispersed generation resource components that are unnecessary or counterproductive to the reliability of the BPS. The SDT's focus has been to ensure that Reliability Standards are applied to dispersed power producing resources to support an effective defense-in-depth strategy and ~~an a~~dequate ~~l~~level of ~~r~~Reliability for the ~~reliability of the~~ interconnected BPS.

For purposes of this effort, dispersed ~~generation power producing~~ resources are those individual resources that aggregate to a total capacity greater than 75 MVA gross nameplate rating, and that are connected through a system designed primarily for delivering such capacity to a common point of connection at a voltage of 100 kV or above. This request is related to the approved definition of the BES from Project 2010-17,¹⁰ which resulted in the inclusion of distinct components of dispersed generation resources.

3.1 BES Definition

The BES definition¹¹ includes the following inclusion criterion addressing dispersed generation resources:

14. Dispersed power producing resources that aggregate to a total capacity greater than 75 MVA (gross nameplate rating), and that are connected through a system designed primarily for delivering such capacity to a common point of connection at a voltage of 100 kV or above. Thus, the facilities designated as BES are:

- a) The individual resources, and*
- b) The system designed primarily for delivering capacity from the point where those resources aggregate to greater than 75 MVA to a common point of connection at a voltage of 100 kV or above.*

~~Upon implementation of Inclusion 14, NERC standards and requirements applicable to Generator Owners and Generator Operators will apply to owners and operators of all of the components included in the definition, notably each individual generator of a dispersed generation resource facility in those requirements, except in certain standards that explicitly identify the applicable facilities or provide specific guidance on applicability to dispersed generation resources.~~

The *BES Definition Reference Document*¹² includes a description of what constitutes dispersed generation resource:

“Dispersed power producing resources are small-scale power generation technologies using a system designed primarily for aggregating capacity

¹⁰ http://www.nerc.com/pa/Stand/Pages/Project2010-17_BES.aspx

¹¹ Glossary of Terms Used in NERC Reliability Standards, updated March 12, 2014.
http://www.nerc.com/pa/Stand/Glossary%20of%20Terms/Glossary_of_Terms.pdf

¹² Bulk Electric System Definition Reference Document, Version 2, April 2014.
http://www.nerc.com/pa/Stand/Project%20201017%20Proposed%20Definition%20of%20Bulk%20Electri/bes_phase2_reference_document_20140325_final_clean.pdf.

providing an alternative to, or an enhancement of, the traditional electric power system. Examples could include but are not limited to: solar, geothermal, energy storage, flywheels, wind, micro-turbines, and fuel cells.”

3.2 Dispersed Power Producing Resources

Dispersed power producing resources are often considered to be variable energy resources such as wind and solar. This description is not explicitly stated in the BES definition; however, NERC and FERC characterize variable generation in this manner regarding the purpose of Inclusion I4 of the definition.¹³ Therefore, the SDT is considering the reliability impacts of variable generation that depends on a primary fuel source which varies over time and cannot be stored.¹⁴ Reliably integrating high levels of variable resources – wind, solar, ocean, and some forms of hydro – into the BPS require significant changes to traditional methods used for system planning and operation.¹⁵ While these resources provide challenges to system operation, these resources are instrumental in meeting government-established renewable portfolio standards and requirements that are based on vital public interests.¹⁶

3.2.1 Design Characteristics

For dispersed power producing resources to be economically viable, it is necessary for the equipment to be geographically dispersed. The generating capacity of individual generating modules can be as small as a few hundred watts to as large as several megawatts. Factors leading to this dispersion requirement include:

- Practical maximum size for wind generators to be transported and installed at a height above ground to optimally utilize the available wind resource;
- Spacing of wind generators geographically to avoid interference between units;
- Solar panel conversion efficiency and solar resource concentration to obtain usable output; and
- Cost-effective transformation and transmission of electricity.

The utilization of ~~these~~ small generating units results in a large number of units (e.g., several hundred wind generators or several million solar panels) installed collectively as a single facility that is connected to the ~~transmission~~ Transmission system.

Dispersed ~~generation power producing~~ resources interconnected to the transmission system typically have a control system at the group level that controls voltage and power output of the ~~facility~~ Facility. The control system is capable of recognizing the capability of each individual unit or inverter to appropriately distribute the contribution required of the ~~facility~~ Facility across the available units or inverters. The

¹³ NERC December 13, 2013 filing, page 15 (FERC Docket No. RD14-2); NERC December 13, 2013 filing, page 17 (FERC Docket No. RD14-2); NERC January 25, 2012 filing, page 18 (FERC Docket No. RD14-2), FERC Order Approving Revised Definition, Docket No. RD14-2-000, Issued March 20, 2014.

¹⁴ “Electricity Markets and Variable Generation Integration,” WECC, January 6, 2011. <https://www.wecc.biz/committees/StandingCommittees/JGC/VGS/MWG/ActivityM1/WECC%20Whitepaper%20-%20Electricity%20Markets%20and%20Variable%20Generation%20Integration.pdf>

¹⁵ “Accommodating High Levels of Variable Generation,” NERC, April, 2009. http://www.nerc.com/files/ivgtf_report_041609.pdf

¹⁶ See Rules Concerning Certification of the Electric Reliability Organization; and Procedures for the Establishment, Approval, and Enforcement of Electric Reliability Standards, Order No. 672, FERC Stats. & Regs. ¶ 31,204, at P 335, order on reh’g, Order No. 672-A, FERC Stats. & Regs. ¶ 31,212 (2006).

variable generation control system must also recognize and account for the variation of uncontrollable factors such as wind speed and solar irradiance levels. Thus, for some standards discussed in this paper it is appropriate to apply requirements at the plant level rather than the individual generating unit.

3.2.2 Operational Characteristics

Dispersed [generation-power producing](#) resources often rely on a variable energy source (wind, for example) that is not able to be stored. Because of this, a ~~facility~~Facility operator cannot provide a precise forecast of the expected output to a Balancing Authority (BA), Transmission Operator (TOP) or Reliability Coordinator (RC); however, short-term forecasting capability is improving and thus reducing uncertainty.¹⁷ The forecasting and variable operating conditions are well understood by BAs, TOPs, and RCs as evidenced by the successful operation of these generating resources over the years. Dispersed generation resources by their nature result in each individual generating unit potentially experiencing varied power system parameters (e.g. voltage, frequency, etc.) due to varied impedances and other variations in the aggregating facilities design.

Many older dispersed [generation-power producing](#) resources are limited in their ability to provide essential reliability services. However, due to technological improvements, newer dispersed generation resources are capable of providing system support for voltage and frequency. For efficiency, the facilities are designed to provide the system requirements at the point of interconnection to the transmission system.

3.2.3 Reliability Impact

A dispersed [generation-power producing](#) resource is typically made up of many individual generating units. In most cases, the individual generating units are similar in design and from one manufacturer. The aggregated capability of the ~~facility~~Facility may in some cases contribute significantly to the reliability of the BPS. As such, there can be reliability benefits from ensuring the equipment utilized to aggregate the individual units to a common point of connection are operated and maintained as required in certain applicable NERC standards. When evaluated individually, however, the individual generating units often do not provide a significant impact to BPS reliability, as the unavailability or failure of any one individual generating resource may have a negligible impact on the aggregated capability of the ~~facility~~Facility. The SDT acknowledges that FERC addressed the question of whether individual resources should be included in the BES definition in Order Nos. 773 and 773-A and concluded that individual wind turbine generators should be included as part of the BES. The SDT is not challenging this conclusion, but rather is addressing the applicability of standards on a requirement-by-requirement basis as necessary to account for the unique characteristics of dispersed generation. Thus, the applicability of requirements to individual generating units may be unnecessary except in cases where a common mode issue exists that could lead to a loss of a significant number of units or the entire ~~facility~~Facility in response to a transmission system event.

¹⁷ “*Electricity Markets and Variable Generation Integration*,” WECC, January 6, 2011. <https://www.wecc.biz/committees/StandingCommittees/JGC/VGS/MWG/ActivityM1/WECC%20Whitepaper%20-%20Electricity%20Markets%20and%20Variable%20Generation%20Integration.pdf>

3.3 Drafting Team Efforts

The SDT ~~is~~ ~~ed~~ing this project in multiple phases. First, after a thorough discussion of the new definition of the BES, the SDT reviewed each standard, as shown in Appendix A, at a high level to recommend changes that would promote consistent applicability for dispersed ~~generation-power producing~~ resources through the entire set of Reliability Standards. This review provided the type of changes proposed, the justification for the changes, and the priority of the changes. The SDT ~~has~~ documented its review in this ~~white paper~~ **White Paper**, which will continue to be updated throughout the SDT efforts. The second phase, currently in progress, includes revising standards where necessary, ~~addressing high-priority issues first~~, and supporting the balloting and commenting process.

3.3.1 Scope of Standards Reviewed

Initially, the focus of the standards review was on standards and requirements applicable to GOs and GOPs. However, during discussions, a question was raised to the SDT whether consideration is necessary for other requirements that affect the interaction of a Balancing Authority (BA), Transmission Operator (TOP), or Reliability Coordinator (RC) with individual BES Elements. For example, a requirement that states “an RC shall monitor BES Elements” may unintentionally affect the RC operator due to the ~~newly~~ revised BES definition. As such, the SDT ~~decided to take~~took a high-level look at all standards adopted by the NERC Board of Trustees (~~Board~~) or approved by FERC to ensure this issue ~~was~~is not significant.

All standards that were reviewed are listed in Appendix A along with the status of the standards as of ~~July 2~~December 11, 2014. ~~There are several new standards included in Appendix A that the drafting team will review and provide updates within this paper if applicability changes are needed. These standards include IRO-001-3, IRO-005-4, MOD-031-1, TOP-002-3, and TOP-003-2.~~ The fields in Appendix A include the following:

- List of standards (grouped by approval status)
- Approval status of the standards which include
 - Subject to Enforcement
 - Subject to Future Enforcement
 - Filed and Pending Regulatory Approval
 - Pending Regulatory Filing
 - Designated for Retirement (2 standards – MOD-024-1 and MOD-025-1 – officially listed as Filed and Pending Regulatory Approval but will be superseded by MOD-025-2)
 - In concurrent active development
- Indication of change or additional review necessary

The SDT also reviewed, at a high-level, any approved regional standards. In cases where a change is recommended to a regional standard, the SDT will notify the affected Region. In addition, the SDT is prepared to provide recommendations to other active NERC standard development efforts, where ~~appropriate~~sc1].

Status	Number of Standards	Number of Standards to be Addressed (Standard, RSAW, Guidance or Further Review)
NERC Standards	166	27
Subject to Enforcement	101	12
Subject to Future Enforcement	20	5
Pending Regulatory Approval	28	4
Pending Regulatory Filing	7	0
Designated for Retirement	2	0
Proposed for Remand	8	6
Region-specific Standards (*Out of Scope)	17	4
Subject to Enforcement	15	3
Subject to Future Enforcement	2	1
Pending Regulatory Approval	0	0
Grand Total	183	31

3.3.2 Reliability Objectives Principles

The SDT used the following Reliability Objectives Principles to review the standards:

- Interconnected bulk power systems shall be planned and operated in a coordinated manner to perform reliably under normal and abnormal conditions as defined in the NERC Standards.
- The frequency and voltage of interconnected bulk power systems shall be controlled within defined limits through the balancing of real and reactive power supply and demand.
- Information necessary for the planning and operation of interconnected bulk power systems shall be made available to those entities responsible for planning and operating the systems reliably.
- Plans for ~~emergency~~-Emergency operation and system restoration of interconnected bulk power systems shall be developed, coordinated, maintained, and implemented.
- Facilities for communication, monitoring, and control shall be provided, used, and maintained for the reliability of interconnected bulk power systems.
- Personnel responsible for planning and operating interconnected bulk power systems shall be trained, qualified, and have the responsibility and authority to implement actions.
- The reliability of the interconnected bulk power systems shall be assessed, monitored, and maintained on a wide-area basis.
- Bulk power systems shall be protected from malicious physical or cyber attacks.

3.3.3 Prioritization Methodology

The SDT established a prioritization ~~for to the~~ review and ~~modification of~~ applicability changes recommended to NERC standards and requirements. The SDT evaluated each requirement to identify the appropriate applicability to support reliability of the BPS. ~~After the SDT identified a standard or requirement where changes to the applicability are warranted, it performed a prioritization.~~ In general, any standard or requirement ~~in which~~ the SDT ~~believes modifications are~~ determined required modification was required has been assigned a high, medium, or low priority. The standards and requirements priorities were established as follows:

- High priority was assigned so that standard or requirement changes would be made quickly enough to avoid an entity having to expend inordinate resources prematurely to comply with a

standard or requirement that, after appropriate modification, would not be applicable to that entity.

- Medium priority was assigned if significant effort and resources with no appreciable reliability benefit would be required by an entity to be compliant; and
- Low priority was assigned to other changes that may need to be made to further ensure requirements add to reliability, but are not perceived as a significant compliance burden.

The prioritization of each recommendation is identified in Appendix B.

- List of standards (grouped by priority)
- Approval status of the standards (same designations as used in Appendix A)
- Recommendation of changing the ~~applicability section~~ Applicability Section of the standard or by changing the applicability for specific requirements
- Recommendation of which applicability options should apply.

~~The SDT remains on schedule to complete its recommendations on the high priority standards by the November 2014 NERC Board of Trustees (Board) meeting, with recommendations on the medium and low priority standards by the February 2015 Board meeting.~~

5.4 Technical Discussion

This section provides a review of each group of standards, focusing on the impact of the BES definition on reliability and compliance efforts. This discussion proposes a resolution for each standard, whether it is a change in the ~~applicability section~~ Applicability Section or in a specific requirement, clarification in a guidance document, or no action needed.

5.14.1 BAL

The group of BAL standards focuses primarily on ensuring the Balancing Authority (BA) has the awareness, ability, and authority to maintain the frequency and operating conditions within its BA Area. Only two standards in this group affect GO and/or GOP, and no BAL standard reviewed affected the interaction of a host BA, TOP, or RC with individual BES Elements.

5.1.14.1.1 BAL-005 — Automatic Generation Control

The purpose of this standard, as it applies to GOPs, is to ensure that all facilities electrically synchronized to the Interconnection are included within the metered boundary of a BA Area so that balancing of resources and demand can be achieved. Ensuring the ~~facility~~ Facility as a whole is within a BA Area ensures the individual units are included. *Therefore, the applicability of the BAL-005 standard does not need to be changed for dispersed ~~power producing~~ generation resources.*

5.1.24.1.2 BAL-001-TRE-1 — Primary Frequency Response in the ERCOT Region

The purpose of BAL-001-TRE-1 standard is to maintain Interconnection steady-state frequency within defined limits. This standard should be modified to clarify the applicability for dispersed generation power producing resources to the total plant level to ensure coordinated performance. However, this is a

regional standard and not part of the SDT scope. *The SDT will communicate this recommendation to the relevant Region.*

5.24.2 COM

The COM¹⁸ standards focus on communication between the RC, BAs, TOPs, and GOPs. The only requirements in any of the current or future enforceable standards that apply to the GOP are clearly intended to apply to the individual GOP registered functional entity (i.e., requires communication between GOPs, TOPs, BAs, and RCs), not the constituent Elements it operates. Consequently, there is no need to differentiate the GOPs obligation for dispersed ~~generation power producing~~ resources from any other resources. *Therefore, the applicability of the COM-001-2, COM-002-2a, and COM-002-4 standards that were reviewed do not need to be changed for dispersed ~~generation power producing~~ resources^[sc2].*

5.34.3 EOP

The EOP standards focus on emergency operations and reporting. The standards that apply to GO and/or GOP entities are EOP-004 and EOP-005. No EOP standard reviewed affects the interaction of a host BA, TOP, or RC with individual BES Elements.

5.3.14.3.1 EOP-004 — Event Reporting

The purpose of this standard is to improve the reliability of the BES by requiring the reporting of events by Responsible Entities. The requirements of this standard that apply to the GO and GOP appear to apply to the individual GO and GOP registered functional entity, not the constituent elements. *The SDT has considered whether there is a need to differentiate dispersed ~~power producing generation~~ resources from any other GO and/or GOP resource and determined that no changes are required to the standard.*

5.3.24.3.2 EOP-005 — System Restoration from Blackstart Resources

EOP-005 ensures plans are in place to restore the grid from a de-energized state. The requirements that apply to a GOP are primarily for individual generation facilities designated as Blackstart Resources, with one requirement to participate in restoration exercises or simulations as requested by the RC. The inclusion of Blackstart Resources is already identified in the BES definition through Inclusion I3. The expectation is that all registered GOPs will participate in restoration exercises as requested by its RC. *Therefore, the applicability of EOP-005 does not need to be changed for dispersed ~~power producing generation~~ resources.*

5.44.4 FAC

The FAC standards focus on establishing ratings and limits of the ~~facility~~ Facility and interconnection requirements to the BES. Several standards apply to GOs and/or GOPs. No FAC standard reviewed affects the interaction of a host BA, TOP, or RC with individual BES Elements.

5.4.14.4.1 FAC-001 — Facility Connection Requirements

Requirements R2 and R3 of this standard apply to any GO that has an external party applying for interconnection to the GO's existing Facility in order to connect to the transmission system. This scenario

¹⁸ ~~Note that COM-002-2a and COM-002-3, which are Pending Regulatory Filing, will be replaced by COM-002-4.~~

is uncommon and there is no precedent for applicability of this standard to dispersed *power producing generation* resources known to the SDT. Current practice primarily includes the GO stating that they will comply with the standard if this scenario is ever realized. This standard allows the GO to specify the conditions that must be met for the interconnection of the third-party, thus providing inherent flexibility to tailor the requirements specifically for the unique needs of the Facility. ~~Furthermore, in 2012, the NERC Integration of Variable Generation Task Force (IVGTF) provided some suggested changes¹⁹ to this standard for the next version. The IVGTF report included modifying requirements to this standard as well as recommended guidance for considering integration of variable generation plants. The recommendations on Standards changes are technology neutral and independent of the type of generation. For these reasons~~Therefore, the applicability of FAC-001 does not need to be changed for dispersed power producing resources.

5.4.24.4.2 FAC-002 — Coordination of Plans for New Facilities

The purpose of FAC-002 is to ensure coordinated assessments of new facilities. The requirement applicable to GOs requires coordination and cooperation on assessments to demonstrate the impact of new facilities on the interconnected system and to demonstrate compliance with NERC standards and other applicable requirements. The methods used to demonstrate compliance are independent of the type of generation and are typically completed at the point of interconnection. *Therefore, the applicability of FAC-002 does not need to be changed for dispersed power producing generation resources.*

5.4.34.4.3 FAC-003 — Transmission Vegetation Management

The purpose of this standard is to ensure programs and efforts are in place to prevent vegetation-related outages. This standard applies equally to dispersed generation facilities and traditional Facilities in both applicability and current practices, as it pertains to overhead transmission lines of applicable generation interconnection Facilities. *Therefore, the applicability of FAC-003 does not need to be changed for dispersed power producing generation resources.*

5.4.44.4.4 FAC-008 — Facility Ratings

FAC-008 ensures ~~facility~~Facility ratings used in the planning and operation of the BES are established and communicated. The ~~facility~~Facility ratings requirement has historically been applicable to dispersed power producing resources and current practices associated with compliance are similar to traditional generation facilities. There is inherent flexibility in the standard requirements for the GO to determine the methodology utilized in determining the ~~facility~~Facility ratings.

To identify the ~~facility~~Facility rating of a dispersed power producing resource the analysis of the entire suite of ~~facility~~Facility components is necessary to adequately identify the minimum and maximum Facility Rating and System Operating Limits, and thus there would be no differentiation between the compliance obligations between dispersed power producing resources and traditional generation. *The SDT believes the industry and Regions would benefit from additional guidance on FAC-008 in the form of changes to add a technical guidance section to the standard the corresponding RSAW, and as follows: or other guidance.*

¹⁹http://www.nerc.com/files/2012_IVGTF_Task_1_3.pdf

~~The applicability language in the standard is somewhat ambiguous as this language can potentially be interpreted to exclude the non-BES equipment from the generator to the low side terminals of the step up transformer (transformer with at least one winding at 100 kV). The use of the term “main step up transformer” in Requirements R1 and R2 refers to the final GSU (the last transformer(s) used exclusively for stepping up the generator output) prior to the point of interconnection or, when the point of interconnection is before the GSU, the GSU that steps up voltage to transmission line voltage level and is used strictly as a delineation point between Requirements R1 and R2. In an attempt to address this potential misinterpretation, the SDT provides the following clarifications:~~

- ~~0. Referencing the NERC Glossary definition of Facility Ratings, identifies that the voltage, current, frequency, real or reactive power flow through a facility must not violate the equipment rating of any equipment of the facility (which is subjected to the voltage, current, etc.). With this definition, it is clear that each component or piece of equipment must be reviewed to ensure the ratings are not exceeded, and that applicable documentation be maintained.~~
- ~~0. The use of the term “Facilities” in the phrase “...determining the Facility Ratings of its solely and jointly owned generator Facility(ies) up to the low side terminals of the main step up transformer...” could potentially be interpreted to refer only to BES Facilities because the Glossary definition of “Facility” includes the term “Bulk Electric System Element,” and for dispersed power producing facilities could leave out portions of the facility, specifically the collection system. However, the intent of the standard is to address the Facility Ratings of all electrical equipment from the generator to the point of interconnection.~~

~~As an example for solar arrays provide ratings for Array or Panel, DC Cables (Positive and Negative), Combiner Boxes, Inverters, as well as associated breakers, Instrument transformers (CVT's, PT's), disconnect switches, and relays, etc. This is shown in Figure X~~

~~If there are multiple chains with the same ratings then only one path needs to be provided with a “multiplier number” for that piece of equipment when calculating the facility rating value. For example; A facility is comprised of 50 identical inverter units rated at 2 MW, which have identical Combiner Box, Module string and module compositions/orientations; then the Facility rating would be $50 * 2 \text{ MW} = 100 \text{ MW}$.~~

~~In order to identify the most limiting component of the facility a complete analysis of every component in a sample unit must be conducted. This will include analysis from the generator (solar module or WTG) up through the high side terminals of the main step up transformer. In an effort to simplify this analysis, grouping of identical equipment configurations into a sample unit is an accepted industry practice. The following discussion and diagrams provide an explanation of how this could be accomplished for dispersed power producing resources (wind and solar).~~

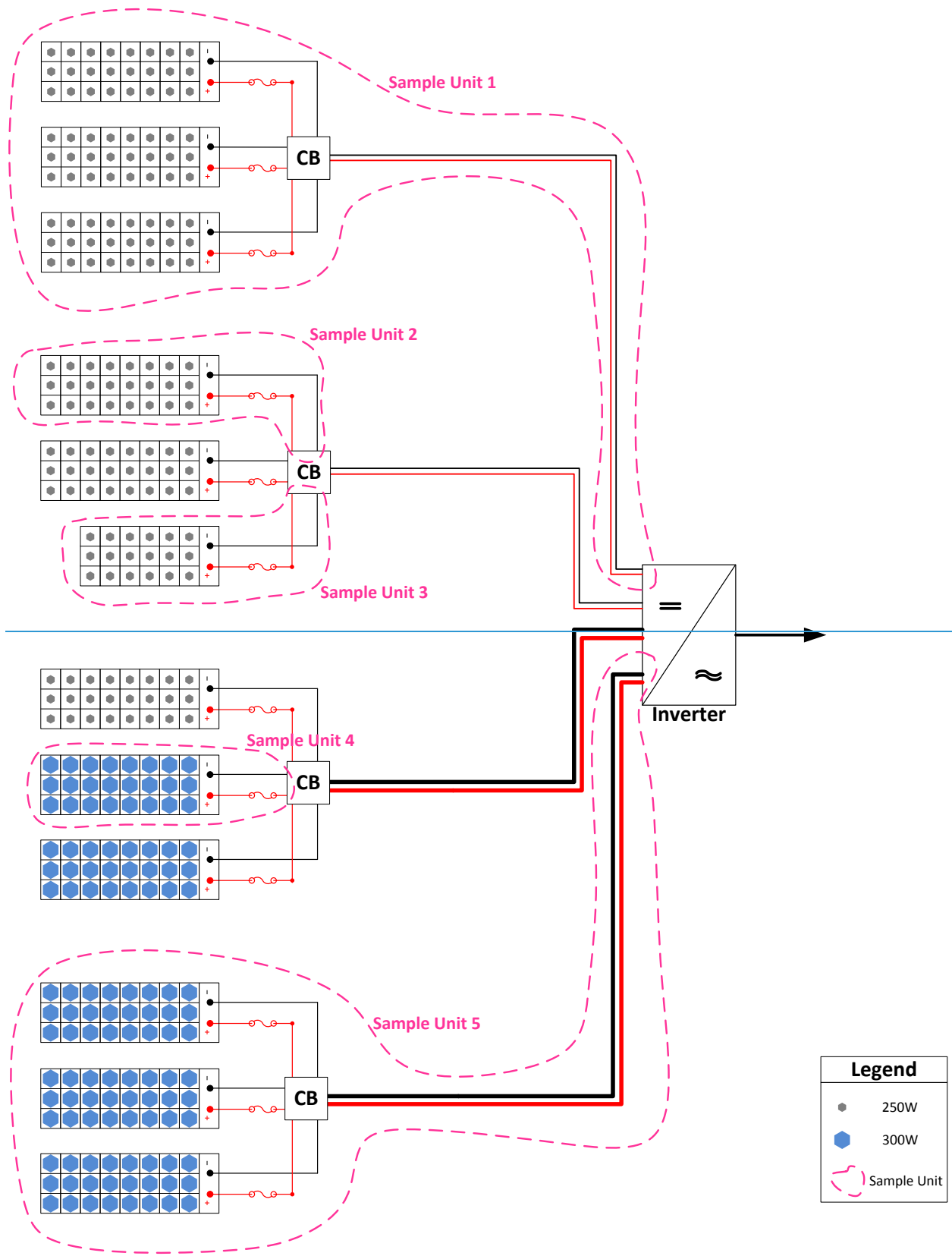

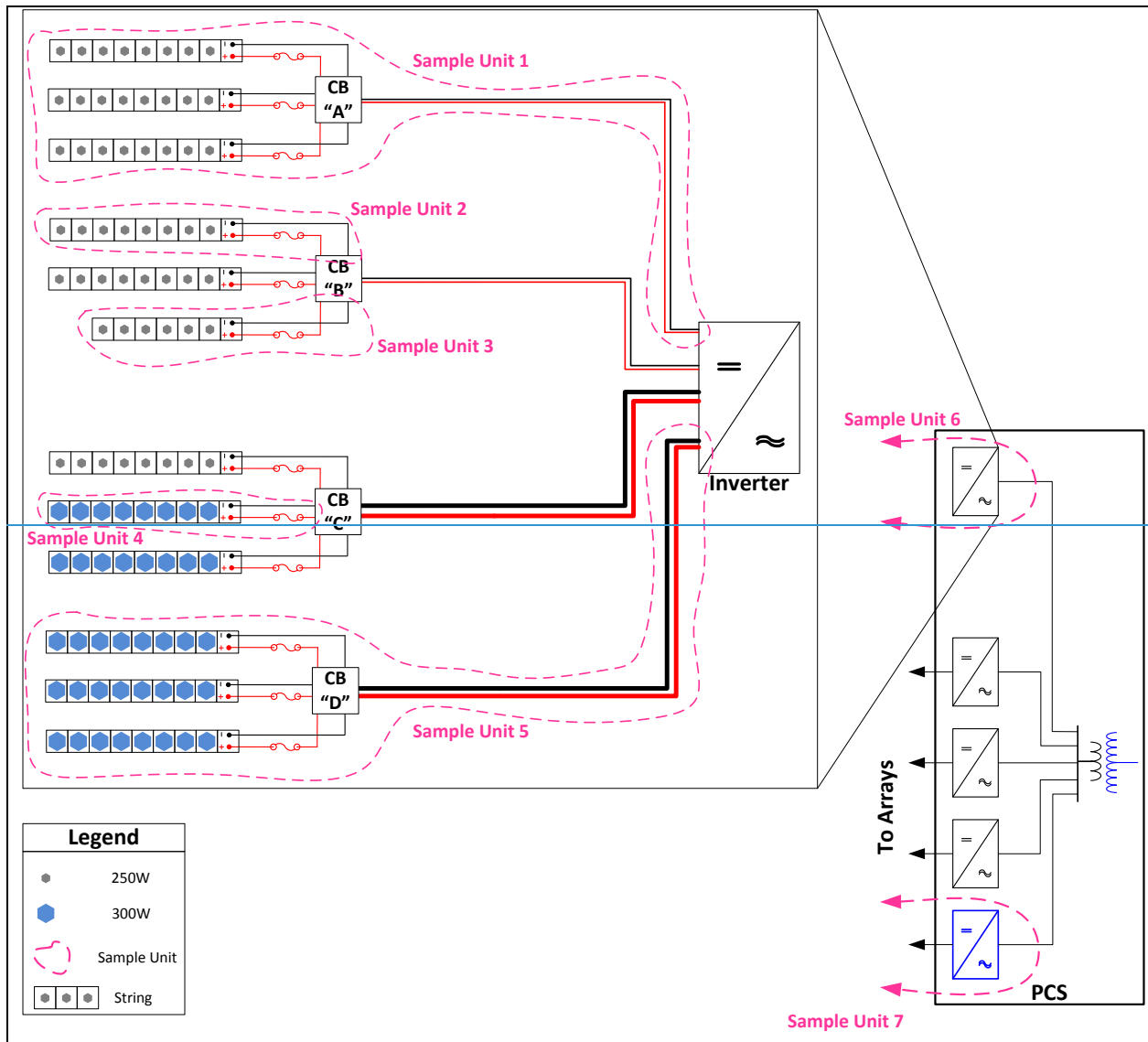

Once a complete analysis of the sample unit is completed, this sample unit can then be referred to in future rating analysis without repeating the complete sample unit analysis.

<u>Element</u>	<u>Unit Rating</u>	<u>#Units in system</u>	<u>Rating</u>
<u>Sample Unit #1 (Nine strings of Eight 250 W modules each)</u>	<u>18 kW</u>	<u>1</u>	<u>18 kW</u>
<u>Sample Unit #2 (Three strings of Eight 250 W modules)</u>	<u>6 kW</u>	<u>3</u>	<u>18 kW</u>
<u>Sample Unit #3 (Three Strings of Six 250 W modules)</u>	<u>4.5 kW</u>	<u>1</u>	<u>4.5 kW</u>
<u>Sample Unit #4 (Three strings of Six 300 W modules)</u>	<u>5.4 kW</u>	<u>2</u>	<u>10.8 kW</u>
<u>Sample Unit #5 (Nine strings of Eight 300 W modules each)</u>	<u>21.6 kW</u>	<u>1</u>	<u>21.6 kW</u>
<u>Sample Unit #6</u>	<u>80 kW</u>	<u>4</u>	<u>320 kW</u>
<u>Sample Unit #7</u>	<u>80 kW</u>	<u>1</u>	<u>80 kW</u>

Element	Multiplier
15-module String	100
Fuses	100
Positive/Negative DC Cables	200
Combiner Box	20
Inverter	20
Transformer	1

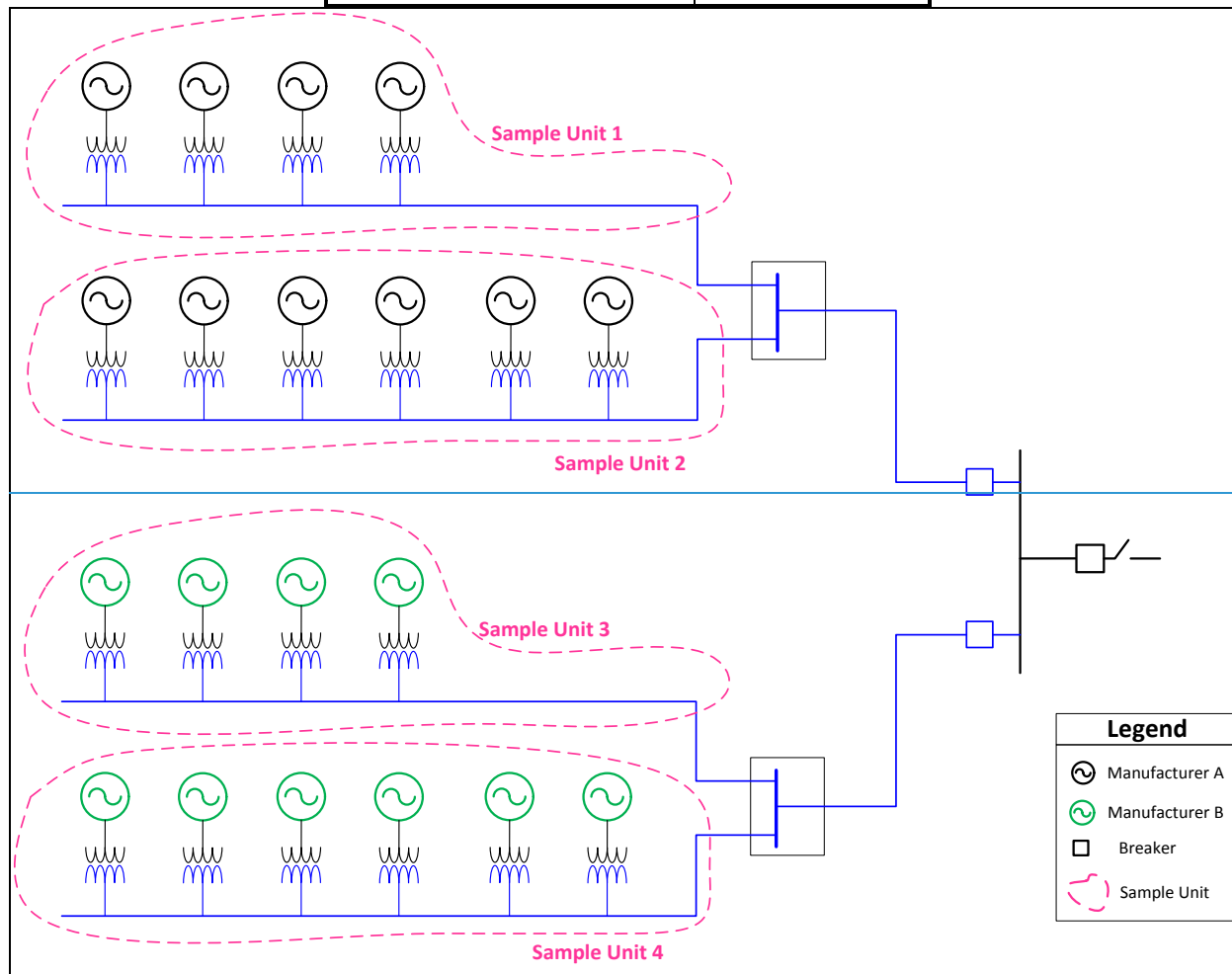

Figure Y: Sample Unit Representation (Wind)

5.454.5 INT

The INT standards provide BAs the authority to monitor power interchange between BA Areas. No INT standard is applicable to the GO or GOP, or affects the interaction of a host BA, TOP, or RC with individual BES Elements. *Therefore, the applicability of the INT standards do not need to be changed for dispersed power producing generation resources.*

5.46.4.6 IRO

The IRO standards provide RCs their authority. There are three IRO Standards that apply directly to GO and/or GOP entities. There are three standards that apply to the interaction of the RC with individual BES Elements. No other IRO standard reviewed affected the interaction of a host BA, TOP, or RC with GOs and/or GOPs.

5.46.14.6.1 IRO-001 — Reliability Coordination — Responsibilities and Authorities²⁰

The purpose of these standards and their requirements as applicable to a GOP is to ensure RC directives are complied with so long as they do not violate safety, equipment, or regulatory or statutory requirements, or cannot be physically implemented. If a GOP is unable to follow a RC directive they are to inform the RC immediately of such.

Directives from RCs have been traditionally applied to the dispersed power producing resource at the aggregate ~~facility~~ Facility level when they are related to either active power or voltage, such as an output reduction or the provision of voltage support. When such directives are not specific to any one Element within the Facility, it is up to the GOP to determine the appropriate method to achieve the desired result of the directive consistent with other applicable NERC Reliability Standards. When an RC directive specifies a particular Element or Elements at the GOP's ~~facility~~ Facility, it is the expectation and requirement that the GOP will act as directed, so long as doing so does not violate safety, equipment, or regulatory or statutory requirements or cannot be physically implemented. For example, a directive could specify operation of a particular circuit breaker at a GOP Facility. *For these reasons, the applicability of IRO-001 does not need to be changed for dispersed ~~generation-power producing~~ resources.*

5.46.24.6.2 IRO-005 — Reliability Coordination — Current Day Operations²¹

The purpose of this standard and its requirements as it relates to GOPs is to ensure when there is a difference in derived limits the BES is operated to the most limiting parameter. A difference in derived limits can occur on any Element and therefore any limitation of the applicability of this standard may create a reliability gap. There is no need to differentiate applicability to dispersed generation resources from any other GOP resources. *Therefore, the applicability of IRO-005 does not need to be changed for dispersed ~~generation-power producing~~ resources.*

5.46.34.6.3 IRO-010 — Reliability Coordinator Data Specification and Collection

The purpose of this standard and its requirement(s) as it relates to GOs and GOPs is to ensure data and information specified by the RC is provided. As each RC area is different in nature, up to and including the tools used to ensure the reliability of the BPS, a 'one size fits all' approach is not appropriate. This Reliability Standard allows for the RC to specify the data and information required from the GO and/or the GOP, based on what is required to support the reliability of the BPS. *Therefore, the applicability of IRO-010 does not need to be changed for dispersed ~~power producing generation~~ resources.*

²⁰ Note that IRO-001-3, which is adopted by the ~~NERC BOT~~ Board, was included in the proposed remand by FERC and is subject to revision as part of Project 2014-3 – Revisions to TOP and IRO Standards.

²¹ Note that applicability to GOPs has been removed in IRO-005-4, which is adopted by the ~~Board~~ NERC BOT. However, this standard was included in the proposed remand by FERC and is subject to revision as part of Project 2014-3 – Revisions to TOP and IRO Standards.

5.474.7 MOD

The MOD group of standards ensures consistent modeling data requirements and reporting procedures. The MOD standards provide a path for Transmission Planners (TPs) and Planning Coordinators (PCs) to reach out to entities for specific modeling information, if required. The SDT believes the existing and proposed modeling standards are sufficient for modeling dispersed ~~generation power producing~~ resources. However, due to the unique nature of dispersed ~~power producing generation~~ resources and an effort to bring consistency to the models, *the SDT believes additional guidance on the MOD standards would be beneficial and will communicate its determination to with other groups responsible for developing such guidance, e.g., the NERC Planning Committee and the MOD-032 SDT, in their determination of whether developing guidelines would be valuable to support accurate modeling.*

5.47.14.7.1 MOD-010 — Steady-State Data for Transmission System Modeling and Simulation

This standard is anticipated to be retired in the near future. There is no need to differentiate dispersed generation resources from any other GOP resources as discussed in 5.7.8 regarding MOD-032. *Therefore, the applicability of MOD-010 does not need to be changed for dispersed generation resources.*

5.47.24.7.2 MOD-012 — Dynamics Data for Transmission System Modeling and Simulation

This standard is anticipated to be retired in the near future. There is no need to differentiate dispersed generation resources from any other GOP resources as discussed in 5.7.8 regarding MOD-032. *Therefore, the applicability of MOD-012 does not need to be changed for dispersed generation resources.*

5.47.34.7.3 MOD-024-1 — Verification of Generator Gross and Net Real Power Capability

This standard was established to ensure accurate information on generator gross and net Real Power capability is available for steady-state models used to assess BES reliability. This standard will be superseded by MOD-025-2.²² *Therefore, the applicability of MOD-024-1 does not need to be changed for dispersed generation resources.*

5.47.44.7.4 MOD-025-1 — Verification of Generator Gross and Net Reactive Power Capability

This standard was established to ensure accurate information on generator gross and net Reactive Power capability is available for steady-state models used to assess BES reliability. This standard will be superseded by MOD-025-2. *Therefore, the applicability of MOD-025-1 does not need to be changed for dispersed generation resources.*

5.47.54.7.5 MOD-025-2 — Verification and Data Reporting of Generator Real and Reactive Power Capability and Synchronous Condenser Reactive Power Capability

The purpose of MOD-025-2 is to ensure that accurate information on generator gross and net Real and Reactive Power capability is available for planning models used to assess BES reliability. This standard is appropriate for and includes specific provisions for dispersed generation resources to ensure changes in

²² MOD-024-1 and MOD-025-1 are ~~NERC BOT Board~~ Adopted but not subject to enforcement. They are commonly followed as good utility practice.

capabilities are reported. *Therefore, the SDT will recommend further evaluating whether to revise to 4.2.3 the applicability of the standard to align the language with the revised BES definition.*

5.47.64.7.6 MOD-026 — Verification of Models and Data for Generator Excitation Control System or Plant Volt/Var Control Functions

This standard provides for verification of models and data for voltage control functions. This standard is appropriate for dispersed generation resources. ~~to ensure changes in control systems and capabilities are reported. However~~ Originally, the DGR SDT considered ~~recommends~~ clarifying the applicability ~~to ensure~~ of the Facilities section ~~aligns with dispersed generation resources, however, upon further review, the DGR SDT recommends no change.~~

5.47.74.7.7 MOD-027 — Verification of Models and Data for Turbine/Governor and Load Control or Active Power/Frequency Control Functions

This standard was established to verify that the turbine/governor and frequency control model accurately represent generator unit Real Power response to system frequency variations. This standard is appropriate for dispersed generation resources ~~to ensure changes in control systems and capabilities are reported. Originally, the DGR SDT considered clarifying the applicability of the Facilities section, however, upon further review, the DGR SDT recommends no change. However, the SDT recommends clarifying the applicability to ensure the Facilities section aligns with dispersed generation resources.~~

5.47.84.7.8 MOD-032 — Data for Power System Modeling and Analysis

The MOD-032 standard was established to ensure consistent modeling data requirements and reporting procedures for the planning horizon cases. The nature of dispersed generation resources is a challenge in modeling the steady-state and dynamic electrical properties of the individual components (e.g. individual units, collector system, interconnection components, etc.).

Models for dispersed ~~generation power producing~~ resources are typically proprietary and unique for each ~~facility~~ Facility. Generic models exist for dynamic analysis that may provide sufficient accuracy in lieu of a ~~facility~~ Facility-specific model. Some sections of the MOD-032 Attachment 1 pertain to modeling individual units, which may not be feasible. Guidance should be provided to show how to best model dispersed ~~generation power producing~~ resources. Such guidance should require modeling requirements for each type of dispersed ~~power producing generation~~ resource within a ~~facility~~ Facility and aggregate model for each reasonable aggregation point. *The applicability of MOD-032 does not need to be changed for dispersed ~~generation power producing~~ resources.*

5.484.8 NUC

The requirements in standard NUC-001 — *Nuclear Plant Interface Coordination* individually define the applicability to Registered Entities, not to the Elements the entities own or operate. While it is unlikely any Elements that are part of a dispersed ~~power producing generation~~ resource would be subject to an agreement required by this standard, limiting the applicability of this standard could create a reliability gap and thus, there is no need to differentiate applicability to dispersed generation resources. *Therefore, the applicability of the NUC standard does not need to be changed for dispersed ~~generation power producing~~ resources.*

5.494.9 PER

The PER standards focus on operator personnel training. The only requirements in any of the current or future enforceable standards that apply to the GOP is requirement R6 in PER-005-2 – *Operations Personnel Training*, and it is clearly intended to apply to the individual GOP registered functional entity that controls a fleet of generating facilities, not the constituent Elements it operates. As such, there is no need to differentiate dispersed [power producing generation](#) resources from any other GOP resources. *Therefore, the applicability of the PER standards do not need to be changed for dispersed [power producing generation](#) resources.*

5.504.10 PRC

The PRC standards establish guidance to ensure appropriate protection is established to protect the BES.

5.50.14.10.1 PRC-001-1.1 — System Protection Coordination

Requirement R1 requires GOPs to be familiar with the purpose and limitations of Protection System schemes applied in their area. The recently approved changes to the BES definition extend the applicability of this requirement. Often this familiarity is provided to GOP personnel through training on the basic concepts of relay protection and how it is utilized. The basic relaying concepts utilized in protection on the aggregating equipment at a dispersed generation site typically will not vary significantly from the concepts used in Protection Systems on individual generating units.

Requirement R2 requires that GOPs report protective relay or equipment failures that reduce system reliability. Protective System failures occurring within a single individual generating unit at a dispersed [power producing generation](#) resource will not have any impact on overall system reliability and thus it should not be necessary for GOPs to report these failures to their TOP and host BA. Only failures of Protection Systems on aggregating equipment have the potential to impact BPS reliability and may require notification. When interpreted as stated above, no related changes should be required to the existing PRC-001-1 standard, as the BES definition changes do not have an impact on these requirements.

Requirement R3 requires GOPs to coordinate new protective systems. Coordinating new and changes to existing protective relay schemes should be applied to aggregating equipment protection only if a lack of coordination could cause unintended operation or non-operation of an interconnected entity's protection, thus potentially having an adverse impact to the BPS. Existing industry practice is to share/coordinate the protective relay settings on the point of interconnect (e.g. generator leads, radial generator tie-line, etc.) and potentially the main step-up transformer, but not operating (collection) buses, collection feeder, or individual generator protection schemes, as these Protection Systems do not directly coordinate with an interconnected utility's own Protection Systems. Relay protection functions such as under and overfrequency and under and overvoltage changes are independent of the interconnected utility's protective relay settings and the setting criteria are defined in PRC-024.

Requirement R5 requires GOPs to coordinate changes in generation, transmission, load, or operating conditions that could require changes in the Protection Systems of others. A GOP of a dispersed generation resource should be required to notify its TOP of changes to generation, transmission, load, or operating conditions on an aggregate ~~facility~~[Facility](#) level.

Project 2007-06 – System Protection Coordination and Project 2014-03 – Revisions to TOP and IRO Standards are presently revising various aspects of this standard or addressing certain requirements in other standards.

For these reasons, the ~~DGR SDT~~ ~~has~~ coordinated with the other SDTs currently reviewing this standard and ~~has~~ recommended revisions to Requirement R3.1 to indicate that coordination by a GOP with their TOP and host BA of new or changes to protection systems on individual generating units of dispersed power producing resources is not required. ~~account for the unique characteristics of dispersed power producing resources.~~

5.50.24.10.2 PRC-001-2 — System Protection Coordination

The concerns addressed with PRC-001-1.1b are removed in PRC-001-2, which is adopted by the ~~NERC BOTBoard~~. However, this standard was included in the proposed remand by FERC and is subject to revision as part of Project 2014-03 – Revisions to TOP and IRO Standards. This Standard version is not in effect and ~~will be~~ ~~was~~ withdrawn ~~when the currently~~ ~~as the~~ proposed versions of the TOP and IRO Reliability Standards included in Project 2014-3 effectively replace PRC-001-2 and other TOP standards are filed at FERC ~~[see]~~. For this reason, no changes are required.

5.50.34.10.3 PRC-002-NPCC-01— Disturbance Monitoring

PRC-018-1 — Disturbance Monitoring Equipment Installation and Data Reporting

Requirements related to installation of Fault/Disturbance monitoring and/or sequence of events (SOE) recording capabilities on generating units and substation equipment which meet regional specific criteria may require installation of these capabilities on the aggregating equipment at a dispersed ~~generation power producing~~ resource ~~facility~~~~Facility~~, and also requires maintenance and periodic reporting requirements to their RRO. However, these requirements have been previously applicable to the aggregating equipment at these dispersed ~~generation power producing~~ resources, and these capabilities are not required to be installed on the individual generating units. The BES definition changes have no direct impact on applicability of these standards to dispersed ~~generation power producing~~ resources. *Therefore, the applicability of these standards ~~does~~ not need to be changed for dispersed ~~generation power producing~~ resources.*²³

5.50.44.10.4 PRC-004-2.1a – Analysis and Mitigation of Transmission and Generation

Protection System Misoperations

PRC-004-3 — Protection System Misoperation Identification and Correction

Misoperation reporting per PRC-004 is currently a requirement applied on the aggregating equipment at applicable dispersed ~~generation power producing~~ resource sites meeting BPS criteria. The continuation of this analysis and reporting on the aggregating equipment by dispersed generation resource owners can provide value to BPS reliability and should remain in place. However, based on the experience of the SDT, there is minimal impact to BPS reliability for analyzing, reporting and developing Corrective Action Plans for each individual generating unit that trips at a dispersed ~~generation power producing~~ resource site, as the tripping of one or a small number of these units has no material impact to the BPS reliability.

²³ See NPCC CGS-005.

Additionally, reporting of Misoperations on each individual generating unit may result in substantial and unnecessary burdens on both the dispersed generation resource owner and the Regional Entities that review and track the resulting reports and Corrective Action Plan implementations. The SDT recognizes that many turbine technologies do not have the design capability of providing sufficient data for an entity to evaluate whether a Misoperation has occurred. Furthermore, dispersed [power producing generation](#) resources by their nature result in each individual generating unit potentially experiencing varied power system parameters (e.g., voltage, frequency, etc.) due to varied impedances and other variations in the aggregating facilities design. This limits the ability to determine whether an individual unit correctly responded to a system disturbance.

However, the SDT maintains that Misoperations occurring on the Protection Systems of individual generation resources identified under Inclusion I4 of the BES definition do not have a material impact on BES reliability when considered individually; however, the aggregate capability of these resources may impact BES reliability if a large number of the individual generation resources (aggregate nameplate rating of greater than 75 MVA) incorrectly operated or failed to operate as designed during a system event. As such, if a trip aggregating to greater than 75 MVA occurs in response to a system disturbance, the SDT ~~proposes-proposed~~ requiring analysis and reporting of Misoperations of individual generating units for which the root cause of the Protection System operation(s) affected an aggregate rating of greater than 75 MVA of BES Facilities. Note that the SDT selected the 75 MVA nameplate threshold for consistency and to prevent confusion.

The SDT ~~was~~ also ~~is~~ concerned with the applicability of events where one or more individual units tripped and the root cause of the operations was identified as a setting error. In this case, the requirements of PRC-004 would be applicable for any individual units where identical settings were applied on the Protection Systems of like individual generation resources identified under Inclusion I4 of the BES definition.

The SDT ~~concludes-concluded~~ that it is not necessary under PRC-004 to analyze each individual Protection System Misoperation affecting individual generating units of a dispersed [generation power producing](#) resource, ~~but is concerned with the potential for unreported Misoperations involving a common mode failure of multiple individual generating units as described.~~ *The SDT ~~has~~ recommended changes to the applicability of this standard to require misoperation analysis on individual generating units at a dispersed [generation power producing](#) resource site, only for events affecting greater than 75MVA aggregate nameplate; the SDT ~~feels-determined that~~ this will ensure that common mode failure scenarios and their potential impact on BPS reliability are appropriately addressed. The SDT's recommended changes passed industry ballot on November 6, 2014, and were approved by the Board on November 13, 2014, and are currently pending regulatory approval.*

5.50.54.10.5 PRC-004-WECC-1 — Protection System and Remedial Action Scheme Misoperation

Dispersed [generation power producing](#) resource sites typically would not be associated with a WECC Major Transfer Path or Remedial Action Scheme (RAS), and thus would not be affected by PRC-004-WECC-1. If a site were to be involved with one of these paths or schemes, it is likely that associated protection or RAS equipment would be located on the aggregating equipment rather than the individual generating units. As such, the BES definition changes may have an impact on applicability of this

standard to dispersed ~~generation-power producing~~ resources. This standard should be modified to clarify the applicability for dispersed generation resources; however, this is a regional standard and not part of the SDT's scope. *Therefore, the SDT ~~will recommend that the relevant Region communicate this recommendation to the evaluate the standard for modification relevant Region.~~*

5.50.64.10.6 PRC-005-1.1b — Transmission and Generation Protection System Maintenance and Testing

The SDT recognizes that PRC-005-1.1b will be phased out beginning in early 2015. Therefore, the SDT recommends only guidance on PRC-005-1.1b rather than suggesting language changes to the standard. *Therefore, the SDT does not recommend revising the applicability of this standard ~~does not need to be changed~~ for dispersed generation resources, ~~as rather, the SDT provided guidance has been provided in the form of recommended changes recommendations for revisions to the applicable RSAW to NERC staff, which NERC has implemented after consultation with the Regions.~~*

5.50.74.10.7 PRC-005-2.— Protection System Maintenance

PRC-005-3 — Protection System and Automatic Reclosing Maintenance

PRC-005-4~~x~~ — ~~Protection System, Automatic Reclosing, and Sudden Pressure Relaying Maintenance~~ Protection System Maintenance and Testing: Sudden Pressure Relays

The aggregated capability of the individual generating units may in some cases contribute to the reliability of the BPS; as such, there can be reliability benefit from ensuring certain BES equipment utilized to aggregate the individual units to a common point of connection are operated and maintained as required in PRC-005²⁴. When evaluated individually, however, the generating units themselves do not have the same impact on BPS reliability as the system used to aggregate the units. The unavailability or failure of any one individual generating unit would have a negligible impact on the aggregated capability of the ~~faeility~~ Facility; this would be irrespective to whether the dispersed generation resource became unavailable due to occurrence of a legitimate fault condition or due to a failure of a control system, protective element, dc supply, etc.

The protection typically utilized in these generating units includes elements which would automatically remove the individual unit from service for certain internal or external conditions, including an internal fault in the unit. These units typically are designed to provide generation output at low voltage levels, (i.e., less than 1000 V). Should these protection elements fail to remove the generating unit for this scenario, the impacts would be limited to the loss the individual generating unit and potentially the next device upstream in the collection system of the dispersed ~~generation-power producing~~ resource. However, this would still only result in the loss of a portion of the aggregated capability of the ~~faeility~~ Facility, which would be equally likely to occur due to a scenario in which a fault occurs on the collection system.

Internal faults on the low voltage system of these generating units would not be discernible on the interconnected transmission systems, as this is similar to a fault occurring on a typical utility distribution

²⁴ ~~Reliability Standard PRC-005 is currently being revised as part of Project 2007-17.3 — Protection System Maintenance and Testing — Phase 3, available here: http://www.nerc.com/pa/Stand/Pages/Project_2007-17-3_Protection_System_Maintenance_and_Testing_Phase_3.aspx. Any proposed changes to the PRC-005 Reliability Standard will be coordinated with this project. Project 2007-17.1 is considering technical changes and Project 2014-01 will consider any applicability change.~~

system fed from a substation designed to serve customer load. It is important to note that the collection system equipment (e.g., breakers, relays, etc.) used to aggregate the individual units may be relied upon to clear the fault condition in both of the above scenarios, which further justifies ensuring portions of the BES collection equipment is maintained appropriately.

For this reason, activities such as Protection System maintenance on each individual generating unit at a dispersed generation ~~facility~~Facility would not provide any additional reliability benefits to the BPS, but Protection System maintenance on facilities where generation aggregates to 75 MVA or more would. The SDT proposes that the scope of PRC-005 be limited to include only the protection systems that operate at a point of aggregation above 75 MVA nameplate rating. If the aggregation point occurs at a component in the collection system, then the protection systems associated with this component would be in scope. *The SDT has recommended changes to the Applicability ~~section~~Section (Facilities) of PRC-005-2, -3, and -~~4~~4 to indicate that maintenance activities should only apply on the aggregating equipment at or above the point where the aggregation exceeds 75 MVA. The SDT's recommended applicability changes to PRC-005-2 and PRC-005-3 were approved by the Board on November 13, 2014. The SDT's recommended applicability changes to PRC-005-4 were posted for an initial ballot period that ends on January 22, 2014.*

5.50.94.10.8 PRC-006-NPCC-1 — Automatic Underfrequency Load Shedding

PRC-006-SERC -1 — Automatic Underfrequency Load Shedding Requirements

The regional specific PRC-006 standards deviate from the PRC-006-1 standard in that they have specific requirements for GOs. In particular, the NPCC version requires that GOs set their underfrequency tripping to meet certain criteria to ensure reliability of the BPS. Typically a dispersed generation resource site may have underfrequency protection on both the aggregating equipment (i.e., collection buses or feeders) as well as the individual generating units. Were this standard only to apply to aggregating equipment, the net impact to the BPS should a system disturbance occur may still result in a loss of significant generating capacity should each of the individual generating units trip for the event. Therefore it may be appropriate to include the individual generating units at a dispersed generation resource site as subject to this standard. The standard could be interpreted this way as written, but further clarification in the standard language may be considered. While this standard may need to be modified to clarify the applicability for dispersed generation resources, this is a regional standard and not part of the SDT's scope. Therefore, the SDT recommends that the relevant Region evaluate the standard for modification. *Therefore, the SDT will communicate this recommendation to the relevant Region.*

The SERC version of PRC-006 requires GOs to provide, upon request, certain under and overfrequency related setpoints and other related capabilities of the site relative to system disturbances. It may be appropriate to include the capabilities of the individual generating units at a dispersed generation resource site when providing this information; however, it may be sufficient to provide only the capabilities of a single sample unit within a site as these units are typically set identically. This would be in addition to any related capabilities or limitations of the aggregating equipment as well. This may be accomplished by providing clarifications in the requirements sections. While this standard may need to be modified to clarify the applicability for dispersed generation power producing resources, this is a regional standard and not part of the SDT's scope. Therefore, the SDT recommends that the relevant Region evaluate the standard for modification. *Therefore, the SDT will communicate this recommendation to the relevant Region.*

5.50.104.10.9 PRC-015 — Special Protection System Data and Documentation

PRC-016 — Special Protection System Misoperations

PRC-017 — Special Protection System Maintenance and Testing

Relatively few dispersed ~~generation-power producing~~ resources own or operate Special Protection Systems (SPSs); however, they do exist and therefore need to be evaluated for applicability based on the revised BES definition. The vast majority of these SPSs involve the aggregating equipment (transformers, collection breakers, etc.) and not the individual generating units. The SPSs are installed to protect the reliability of the BPS, and as such the aggregated response of the site (e.g., reduction in output, complete disconnection from the BES, etc.) is critical, not the response of individual generating units. *Therefore, the applicability of these standards does not need to be changed for dispersed ~~generation-power producing~~ resources.*

5.50.114.10.10 _____ PRC-019-1 — Coordination of Generating Unit or Plant Capabilities, Voltage Regulating Controls, and Protection

Dispersed ~~generation-power producing~~ resources typically utilize a site level voltage control scheme that directs the individual generating units to adjust their output to meet the voltage requirements at an aggregate ~~facility~~Facility level. In these cases the individual generating units will simply no longer respond once they are “maxed out” in providing voltage or reactive changes, but also need to be properly coordinated with protection trip settings on the aggregating equipment to mitigate risk of tripping in this scenario. For those facilities that solely regulate voltage at the individual unit, these facilities also need to consider the Protection Systems at the individual units and their compatibility with the reactive and voltage limitations of the units. The applicability in PRC-019-1 (section 4.2.3) includes a “Generating plant/~~Facility~~ consisting of one or more units that are connected to the Bulk Electric System at a common bus with total generation greater than 75 MVA (gross aggregate nameplate rating).” *Therefore, the DGR SDT revised the Facilities section of the standard to clarify that facilities which solely regulate voltage at the individual generating unit are subject to this standard’s requirements. The SDT’s recommended applicability changes to PRC-019-1 were posted for an initial comment and ballot period scheduled to close December 22, 2014.*

5.50.124.10.11 _____ PRC-023— Transmission Relay Loadability

Dispersed ~~power producing~~generation resources in some cases contain facilities and Protection Systems that meet the criteria described in the ~~applicability section~~Applicability Section (e.g., load responsive phase Protection System on transmission lines operated at 200 kV or above); however, in the majority of cases these lines are radially connected to the remainder of the BES and are excluded from the standard requirements of PRC-023-3. While certain entities with dispersed ~~generation-power producing~~ resources are required to meet the requirements of PRC-023 on components of their aggregating equipment (e.g., main step-up transformers, interconnecting transmission lines) the standard is not applicable to the individual generating units, as the individual generating units are addressed in PRC-025. The BES definition changes have no direct impact on the applicability of this standard to dispersed ~~generation power producing~~ resources. *Therefore, the applicability of th*is*e standards does not need to be changed for dispersed ~~generation-power producing~~ resources.*

5.50.134.10.12 PRC-024— Generator Frequency and Voltage Protective Relay Settings

If the individual generating units at a dispersed ~~generation-power producing~~ resource were excluded from this requirement, it is possible large portions or perhaps the entire output of a dispersed ~~generation-power producing~~ resource site may be lost during certain system disturbances, negatively impacting BES reliability. The SDT has determined it is appropriate to require that Protection System settings applied on both the individual generating units and aggregating equipment (including any Protection Systems applied on non-BES portions of the aggregating equipment), are set within the “no-trip zone” referenced in the requirements to maintain reliability of the BES. However, for the purpose of compliance evidence, the SDT believes it should be sufficient for an entity to provide evidence for a single sample generating unit within a site rather than providing documentation for each individual unit, providing the entity used that methodology to set its protection systems for all the units, rather than providing documentation for each individual unit. This would be in addition to any Protection System settings evidence for the aggregating equipment. *The SDT therefore recommended changes to the standard requirements to ensure these requirements are applied to the individual power producing resources as well as all equipment, potentially including non-BES equipment, from the individual power producing resource up to the point of interconnection and communicated compliance evidence requirement considerations to NERC staff for RSAW development. The SDT’s recommended applicability changes to PRC-024 were posted for an initial comment and ballot period scheduled to close December 22, 2014.*

The SDT therefore recommended changes to the standard requirements addressing the scope of applicability as stated above and will recommend changes to the RSAW to address documentation options.

5.50.144.10.13 PRC-025— Generator Relay Loadability

The Protection System utilized on individual generating units at a dispersed ~~generation-power producing facility~~Facility may include load-responsive protective relays and thus would be subject to the settings requirements listed in this standard. Were this standard only to apply to aggregating equipment, the net impact to the BPS should a system disturbance occur, may be a loss of significant generating capacity should each of the individual generating units trip for the event. The SDT has determined it is appropriate to require that Protection System settings applied on both the individual generating units at a dispersed ~~generation-power producing~~ resource site as applicable to this standard. However, for the purpose of compliance evidence, the SDT believes it should be sufficient for an entity to provide evidence for a single sample generating unit within a site rather than providing documentation for each individual unit, providing the entity used that methodology to set its protection systems for all the units, rather than providing documentation for each individual unit. This would be in addition to any Protection System settings evidence for the aggregating equipment. As such the SDT recommends the RSAW be modified as stated above. *The SDT recommended ~~no~~ changes to the standard ~~are required~~; however, the DGR SDT communicated compliance evidence requirement considerations to NERC staff for RSAW development. is recommending changes to the RSAW to clarify compliance evidence requirements.*

5.514.11 TOP

The TOP standards provide TOPs their authority. There are four TOP standards that apply directly to GO and GOP entities. The TOP standards as they relate to GOs/GOPs ensure RCs and TOPs can issue directives to the GOP, and the GOP follows such directives. They also ensure GOPs render all available

emergency assistance as requested. Finally, they require GO/GOPs to coordinate their operations and outages and provide data and information to the BA and TOP. No TOP standard refers to the interaction of a host BA, TOP, or RC with individual BES Elements.

5.51.14.11.1 TOP-001-1a — Reliability Responsibilities and Authorities

This standard as it applies to GOPs is reviewed at the requirement level, with only one change recommended.

5.51.1.14.11.1.1 Requirement R3

The purpose of requirement R3 as it relates to GOPs is to ensure the RC and TOP reliability directives are complied with so long as they do not violate safety, equipment, or regulatory or statutory requirements. If a GOP is unable to follow a RC or TOP reliability directive they are to inform the RC or TOP immediately of such. The requirement is applicable to the registered functional entity, not the constituent Elements it operates. *Therefore, there is no need to differentiate applicability to dispersed ~~generation power producing~~ resources from any other GOP resources, and no change to this requirement is needed.*

5.51.1.24.11.1.2 Requirement R6

The purpose of requirement R6 as it relates to GOPs is to ensure all available emergency assistance to others as requested, unless such actions would violate safety, equipment, or regulatory or statutory requirements. The requirement is applicable to the registered functional entity, not the constituent Elements it operates. *Therefore, there is no need to differentiate applicability to dispersed ~~generation power producing~~ resources from any other GOP resources, and no change to this requirement is needed.*

5.51.1.34.11.1.3 Requirement R7

The purpose of requirement R7 as it relates to GOPs is to ensure BES facilities are not removed from service without proper notification and coordination with the TOP and, when time does not permit such prior notification and coordination, notification and coordination shall occur as soon as reasonably possible. This is required to avoid burdens on neighboring systems. It should be noted that the purpose of this standard is to keep the TOP informed of all generating ~~facility~~Facility capabilities in case of an emergency. It is assumed that required notification and coordination from the GOP to the TOP would be done in real-time and through verbal communication media. The concern here is how to apply this to a dispersed ~~power producinggeneration~~ resource ~~facility~~Facility. The SDT recommends that the GOP report at the aggregate ~~facility~~Facility level to the TOP any generator outage above 20 MVA for dispersed ~~power producinggeneration~~ resource facilities. The justification is based on the following:

- This is consistent with Inclusion I2 of the revised BES definition, which addresses only generating units greater than 20 MVA.
- TOP-002-2.1b Requirement R14 requires real-time notification of changes in Real Power capabilities, planned and unplanned. Setting the threshold at 20 MVA would address routine maintenance on a small portion of the ~~facility~~Facility (e.g., 2% of the generators are out of service on any given day) and individual generating units going into a failure. Otherwise, coordinating each individual generating unit outage would burden the TOP without providing an increase in reliability to the interconnected BPS.

Dispersed ~~power producing generation~~ resource outages should be reported as X MW out of Y MW are available. *Therefore, the SDT recommends that a modification to the applicability of this requirement is necessary for dispersed power producing resources for generator outages greater than 20 MVA.*

5.51.24.11.2 TOP-001-23— Transmission Operations²⁵

The purpose of this standard as it relates to GOPs is to ensure TOP directives are complied with so long as they do not violate safety, equipment, or regulatory or statutory requirements. If a GOP is unable to follow a TOP directive they are to inform the TOP immediately of such. It directs the TOP to issue directives and as such the TOP may provide special requirements for dispersed ~~power producing generation~~ resources for its unique capabilities. ~~Note that while this standard is adopted by the NERC BOT, this standard was included in the proposed remand by FERC and is subject to revision as part of Project 2014-03—Revisions to TOP and IRO Standards.~~ *The SDT recommends that Project 2014-3 provide direction for a dispersed ~~power producing generation~~ resource to be only reported at the aggregate facility level. If TOP-001-1a R7 is reintroduced, then the recommendation provided above should be included in their efforts.*

5.51.34.11.3 TOP-002-2.1b — Normal Operations Planning²⁶

This TOP standard has five requirements applied to GOPs. Several modifications are recommended below, and the SDT recommends that the most effective and efficient way to accomplish this is through modification of the Applicability ~~section~~ Section of this standard.

5.51.3.14.11.3.1 Requirement R3

The purpose of requirement R3 as it relates to GOPs is to ensure a GOP's current day, next-day and seasonal operations are coordinated with its ~~Host-host~~ BAs and TSP. This requirement relates to planned operations at a generator and does not include unplanned operations such as forced or emergency operations. The SDT recommends that this requirement be applied at the aggregate ~~facility~~ Facility level for dispersed power producing resources. For example, forecasting available MW at the aggregated ~~facility~~ Facility level is currently one method used. The SDT does not see any reliability gap in that would prompt this team to apply R3 to any point less than the dispersed power resource aggregated ~~facility~~ Facility level.

*The SDT has not found or been made aware of a reliability gap that would prompt this team to apply R3 to any point less than the dispersed power resource aggregated ~~facility~~ Facility level and **recommends such modification to the applicability of this requirement.***

5.51.3.24.11.3.2 Requirement R13

The purpose of requirement R13 as it relates to GOPs is to ensure Real Power and Reactive Power capabilities are verified as requested by the BA and TOP. The SDT believes a modification to the applicability of this requirement is necessary for dispersed power producing resources. The SDT is

²⁵ [Note that TOP-001-2 was adopted by the Board and remanded by FERC. TOP-001-2 is currently under revision as part of Project 2014-03 – Revisions to TOP and IRO Standards, and was posted for additional ballot period that is scheduled to close January 7, 2015 as TOP-001-3.](#)

²⁶ The GOP applicability is removed in TOP-002-3, which was adopted by the ~~NERC BOT~~ Board. However, TOP-002-3 was included in the proposed remand by FERC and is subject to revision as part of Project 2014-3 – Revisions to TOP and IRO Standards.

recommending that this requirement be applied at the aggregate ~~facility~~Facility level for dispersed power producing resources for the following reasons:

- Due to the nature, amount of individual generators at a dispersed power producing resource, internal Real Power losses, and natural inductance and capacitance of dispersed power resource system connected in series, verification of real and reactive capabilities should be conducted at the dispersed power producing resource aggregate ~~facility~~Facility level. Performing verification in this manner will provide an actual net real and reactive capability, which would be seen by both the BA and TOP. In addition, performing verification in this manner is also consistent with operating agreements such as an interconnection agreement, which the dispersed power resource has with the TOP and BA.
- MOD-025-2 also provides that verification for any generator <20MVA may be completed on an individual unit basis or as a “group.” Reporting capability at the aggregated ~~facility~~Facility level is consistent with the MOD-025-2 provision for group verification.

The SDT recommends a modification to the applicability of this requirement at the aggregated ~~facility~~Facility level for dispersed power producing resources.

5.51.3.34.11.3.3 Requirement R14

The purpose of requirement R14 as it relates to GOPs is to ensure BAs and TOPs are notified of changes in real output capabilities without any intentional time delay. It should be noted that the purpose of this requirement is to address unplanned changes in real output capabilities. It is assumed the required notification and coordination from the GOP to the BA and TOP would be done in real-time and through verbal communication media. The concern here is how to apply this to dispersed power producing resources. The SDT recommends that the GOP notify at the aggregate ~~facility~~Facility level to the TOP any unplanned changes in real output capabilities above 20 MVA. The justification is based on the following:

- This is consistent with Inclusion I2 of the revised BES definition which includes generating units greater than 20MVA.
- TOP-002-2.1b R14 requires real-time notification of changes in Real Power capabilities, planned and unplanned. Setting the threshold at 20 MVA would address routine maintenance on a small portion of the ~~facility~~Facility (e.g. 2% of the generators are out of service on any given day) and individual generating units going into a failure. Otherwise, coordinating each individual generating unit outage would burden the TOP without providing an increase in reliability to the interconnected BPS.

Dispersed generation resources changes in real output capabilities should be reported as X MW out of Y MW are available. *The SDT recommends that a modification to the applicability of this requirement is necessary for dispersed power producing resources for unplanned outages greater than 20 MVA.*

5.51.3.44.11.3.4 Requirement R15

The purpose of requirement R15 as it relates to GOPs is to ensure BAs and TOPs are provided a forecast (e.g., seven day) of expected Real Power. The SDT believes this requirement as requested by the BA or TOP is being applied at the aggregate ~~facility~~Facility level for dispersed power producing resources.

Based on the SDT's experience, expected Real Power forecasts (e.g. 5 or 7 forecast) for a dispersed power producing resource has been traditionally coordinated with the BA and TOP at the aggregate ~~facility~~Facility level for dispersed power producing resources. *Therefore, the SDT recommends that R15 be applied at the aggregate ~~facility~~Facility level for dispersed power resources and as such, modification to the applicability of this requirement is necessary.*

5.51.3.54.11.3.5 Requirement R18

The purpose of requirement R18 as it relates to a GOP is to ensure uniform line identifiers are used when referring to transmission facilities of an interconnected network. The standard applies to transmission facilities of an interconnected network, which would not apply to any Elements within the dispersed generation ~~facility~~Facility. There is no need to differentiate applicability to dispersed generation resources from any other GOP resources. *Therefore, the applicability of this requirement does not need to be changed for dispersed generation resources.*

5.51.44.11.4 TOP-003-1— Planned Outage Coordination²⁷

This TOP Standard has three requirements applied to GOPs. Modification to one of these requirements is recommended.

5.51.4.14.11.4.1 Requirement R1

The purpose of requirement R1 as it relates to GOPs is to ensure TOPs are provided planned outage information on a daily basis for any scheduled generator outage >50MW for the next day. *Therefore, the applicability of this requirement does not need to be changed for dispersed generation resources.*

5.51.4.24.11.4.2 Requirement R2

The purpose of requirement R2 as it relates to GOPs is to ensure all voltage regulating equipment scheduled outages are planned and coordinated with affected BAs and TOPs. A modification to the applicability of this requirement is necessary for dispersed power producing resources. The SDT recommends that this requirement be applied at the aggregate ~~facility~~Facility level for dispersed power producing resources.

Based on the SDT's experience, scheduled outages of voltage regulating equipment at a dispersed power producing resource has been traditionally provided to the BA and TOP at the aggregate ~~facility~~Facility level for dispersed power producing resources. Outages of voltage regulating equipment at a dispersed power producing resource are coordinated typically as a reduction in Reactive Power capabilities, specifying whether it is inductive, capacitive or both. Additionally, automatic voltage regulators that do not necessarily provide Reactive Power, but direct the actions of equipment that do supply Reactive Power, are typically coordinated at the aggregate ~~facility~~Facility level as they usually are the master controller for all voltage regulating equipment at the ~~facility~~Facility. A key aspect of the SDT project is to maintain the status quo, if it is determined not to cause a reliability gap. *The SDT has not found or been made aware of a reliability gap, which would prompt this team to apply R2 to any point less than the dispersed power ~~producing r-~~resource aggregated ~~facility~~Facility level and as ~~in-~~such, ~~feels-~~determined a*

²⁷ ~~Note that TOP-003-2, which is adopted by the NERC BOT, was included in the proposed remand by FERC and is subject to revision as part of Project 2014-3—Revisions to TOP and IRO Standards.~~

modification to the applicability of this requirement is necessary for dispersed power producing resources.

5.51.4.34.11.4.3 Requirement R3

The purpose of requirement R3 as it relates to GOPs is to ensure scheduled outages of telemetering and control equipment and associated communication channels are planned and coordinated among BAs and TOPs. Based on the SDT technical expertise, scheduled outages of telemetering and control equipment and associated communication channels at a dispersed power producing resource have been traditionally provided to the BA and TOP at the aggregate ~~facility~~Facility level for dispersed power producing resources. In addition, only scheduled outages of telemetering and control equipment and associated communication channels that can affect the BA and TOP are coordinated with the BA and TOP.

Therefore, the applicability of this requirement does not need to be changed for dispersed ~~generation~~ power producing resources.

5.51.54.11.5 TOP-006 — Monitoring System Conditions

The purpose of this standard as it relates to GOPs is to ensure BAs and TOPs know the status of all generation resources available for use as informed by the GOP. It should also be noted that the purpose of this standard is to ensure critical reliability parameters are monitored in real-time. It then can be extrapolated that the requirement, “GOP shall inform...,” is done by sending dispersed power producing resource telemetry in real-time and through a digital communication medium, such as an ICCP link or RTU. The SDT feels a modification to the applicability of this requirement is necessary for dispersed power producing resources. The SDT is recommending that this requirement be applied at the aggregate ~~facility~~Facility level for dispersed power producing resources for the following reasons:

- This is consistent with Inclusion I2 of the revised BES definition, which includes generating units greater than 20MVA. If removing <20MVA would cause a burden to the BPS, then the threshold for inclusion in the BES would have been less than 20MVA.
- Routine maintenance is frequently completed on a small portion of the entire ~~facility~~Facility (e.g. 2% of the generators are out of service on any given day) such as to not have a significant impact to the output capability of the ~~facility~~Facility. Additionally, it is not uncommon to have individual generating units at a dispersed power producing resource to go into a failure mode due to internal factors of the equipment, such as hydraulic fluid pressure tolerances, gearbox bearing thermal tolerances, etc. As such, coordinating each individual generating unit outage would burden the TOP without providing an increase in reliability to the interconnected BPS.
- As this standard requires real-time monitoring, this is most likely completed through a digital medium such as an ICCP link or RTU. The data that a dispersed power resource provides to the BA and TOP in real-time should include the aggregate active power output of the ~~facility~~Facility, among other telemetry points. These data specifications are usually outlined in interconnection agreements among the parties.

Based on the SDT technical expertise, BAs and TOPs are informed by the GOP of all generation resources available at the dispersed power producing resource at the aggregate ~~facility~~Facility level. Traditionally the dispersed power producing resources are providing the BA and TOP, at minimum, the following telemetry points in real-time: aggregate Real Power, aggregate Reactive Power and main high-side circuit breaker status. A key aspect of the SDT project is to maintain the status quo, if it is

determined not to cause a reliability gap. *The SDT has not found or been made aware of a reliability gap, which would prompt this team to apply these requirement to any point less than where the dispersed power producing resource aggregates and as in such, recommends a modification to the applicability of this requirement is necessary for dispersed power producing resources.*

5.524.12 TPL

At the time of this paper, these standards do not affect GOs or GOPs directly. Input from GO or GOP entities is provided to transmission planning entities through the MOD standards. *Therefore, the applicability of the TPL standards does not need to be changed for dispersed generation-power producing resources. ~~The SDT will continue to coordinate with other SDTs that consider changes that encompass new standards that may implicate potential power producing resource applicability changes.~~*

5.534.13 VAR

The VAR standards exist to ensure that voltage levels, reactive flows, and reactive resources are monitored, controlled, and maintained. There are two VAR Standards that apply to GOs and/or GOPs. The voltage and/or reactive schedule provided by TOPs is specified to be at the point of interconnection or the point specified in the interconnection agreement.

5.53.14.13.1 VAR-001 — Voltage and Reactive Control (WECC Regional Variance)

The purpose of this standard as it relates to GOPs in WECC is to ensure a generator voltage schedule is issued that is appropriate for the type of generator(s) at a specific facilityFacility. Additionally, it requires GOPs to have a methodology for how the voltage schedule is met taking into account the type of equipment used to maintain the voltage schedule. Based on the SDT technical expertise, voltage control and voltage schedule adherence for dispersed power producing resource occurs at the aggregate facilityFacility level. There is no need to differentiate dispersed generation resources from any other GOP resources. *Therefore, the applicability of VAR-001 does not need to be changed for dispersed generation resources.*

5.53.24.13.2 VAR-002-2b — Generator Operation for Maintaining Network Voltage Schedules

VAR-002-3 — Generator Operation for Maintaining Network Voltage Schedules

The purpose of these standards as they relate to GOs and GOPs is to ensure generators operate in automatic voltage control mode as required by the TOP voltage or reactive power schedule provided to ensure voltage levels, reactive flows, and reactive resources are maintained within applicable Facility Ratings to protect equipment and reliability of the Interconnection. Based on the SDT technical expertise, voltage control and voltage schedule adherence for dispersed power producing resource occurs at the aggregate facilityFacility level and such guidance should be provided.

In addition, the voltage-controlling equipment and the methodology to ensure the facilityFacility has an automatic and dynamic response to ensure the TOP's instructions are maintained can be very different for each facilityFacility. It is implied in VAR-001-3 that each TOP should understand capabilities of the generation facilityFacility and the requirements of the transmission system to ensure a mutually agreeable solution/schedule is used.

5.53.34.13.3 VAR-002-2b — Requirement R3.1

VAR-002-3 — Requirement R4

The purpose of these requirements is to ensure that a GOP notifies the TOP, within 30 minutes, any status and capability changes of any generator Reactive Power resource, including automatic voltage regulator, power system stabilizer or alternative voltage controlling device. Based on the experience of the SDT, status and capability changes is traditionally coordinated at the aggregate ~~facility~~Facility level point of interconnection. *Therefore, the SDT has recommended changes to the standard to clarify the applicability of VAR-002-2b R3.1 and VAR-002-3 R4 for dispersed power producing resources. [These changes were successfully balloted in VAR-002-4 on November 6, 2014, and approved by the Board on November 13, 2014.](#)*

5.53.54.13.4 VAR-002-2b — Requirement R4

VAR-002-3 — Requirement R5

The purpose of these requirements is to ensure that Transmission Operators and Transmission Planners have appropriate information and provide guidance to the GOP in regards to Generator Operator's transformers to ensure voltage levels, reactive flows, and reactive resources are maintained within applicable Facility Ratings to protect equipment and reliability of the Interconnection. Based on the experience of the SDT dispersed power producing resources individual generator transformers have traditionally been excluded from the requirements of VAR-002-2b R4 and VAR-002-3 R5, as they are not used to improve voltage performance on the Interconnection. As such, applicability should be limited to transformers with at least one winding at a voltage of 100kV or above. *Therefore, the SDT has recommended changes to the standard to clarify the applicability of VAR-002-2b R4 and VAR-002-3 R5 for dispersed generation resources. [These changes were successfully balloted in VAR-002-4 on November 6, 2014, and approved by the Board on November 13, 2014.](#)*

5.544.14 CIP

5.54.14.14.1 CIP v5[SC4]

[The CIP standards are still under revision in Project 2014-02. The DGR SDT and the CIP SDT continue to coordinate revisions to the CIP standards, and will update this section to reflect the outcome of that effort at the appropriate time.](#)

The CIP standards ensure physical and cyber security for BES Cyber Assets and BES Cyber Systems critical to the reliability and security of the BES. CIP-002 identifies critical assets or systems of a ~~facility~~Facility, while CIP-003 to CIP-011 depend on the outcome of the CIP-002 assessment to determine applicability.

~~The DGR SDT and the CIP SDT continued coordination of possible revisions to the CIP standards.~~

During the Project 2014-02 CIP Version 5 Revisions SDT first comment period, it received comments to modify CIP-003-6 in the ~~applicability section~~Applicability Section. The CIP SDT made drastic modifications to the second posting of CIP-003-6 to take into accounts all of the comments received, which was posted for an additional 45-day comment and ballot period on September 3, 2014.

At its September meeting, the DGR SDT had a focused discussion with the CIP SDT surrounding the technical nature of the dispersed power producing resources and how it relates to the CIP standards. The

coordinating effort resulted in discussions of the revised CIP-003-6. As for that posted revised standard, the CIP SDT took the approach of including an Attachment 1 for Responsible Entities. The Attachment 1 requires elements to be developed in Responsible Entities' cyber security plan(s) for assets containing low impact BES Cyber Systems. The elements in CIP-003-6, Attachment 1 allow flexibility for the controls to be established for each of the main four elements below. The CIP SDT encourages observers of the DGR SDT to review the Attachment 1 in detail. Here is some information regarding the attachment.

Element 1: Security Awareness

The intent of the security awareness program is for entities to reinforce good cyber security practices with their personnel at least once every 15 calendar months. It is up to the entity as to the topics and how it schedules these topics. The Responsible Entity should be able to produce the awareness material that was delivered and the delivery method(s) (posters, emails, topics at staff meetings, etc.) that were used. The SDT does not intend that the Responsible Entity must maintain lists of recipients and track the reception of the awareness material by personnel.

Element 2: Physical Security

The Responsible Entity has flexibility in the controls used to restrict physical access to low impact BES Cyber Systems at a BES asset using one or a combination of access controls, monitoring controls, or other operational, procedural, or technical physical security controls. Entities may utilize perimeter controls (e.g., fences with locked gates, guards, site access policies, etc.) and/or more granular areas of physical access control in areas where low impact BES Cyber Systems are located, such as control rooms or control houses. User authorization programs and lists of authorized users are not required.

Element 3: Electronic Access Controls

Where Low Impact External Routable Connectivity (LERC) or Dial-up Connectivity exists, the Responsible Entity must document and implement controls that include the LERC and Dial-up Connectivity to the BES asset such that the low impact BES Cyber Systems located at the BES asset are protected. Two glossary terms are included in order to help clarify and simplify the language in Attachment 1. The SDT's intent in creating these terms is to avoid confusion with the similar concepts and requirements (ESP, EAP, ERC, EACMS) needed for high and medium impact BES Cyber Systems by utilizing separate terms that apply only to assets containing low impact BES Cyber Systems.

Element 4: Cyber Security Incident Response

The entity should have one or more documented cyber security incident response plans that include each of the topics listed. For assets that do not have LERC, it is not the intent to increase their risk by increasing the level of connectivity in order to have real-time monitoring. The intent is if in the normal course of business suspicious activities are noted at an asset containing low impact BES Cyber Systems, there is a cyber security incident response plan that will guide the entity through responding to the incident and reporting the incident if it rises to the level of a Reportable Cyber Security Incident.

Therefore, the DGR SDT recommends that no changes be made to proposed CIP-003-6. CIP-002-5.1 needs to remain as is because entities must go through the process for identifying and categorizing its BES Cyber Systems and their associated BES Cyber Assets. The controls put in place for proposed CIP-

003-6, Attachment 1, are not burdensome, are realistic and achievable, and does not express undue compliance burden. In conclusion, the DGR SDT states that the reliability objective of these controls are adequate and the applicability of CIP-003-6 should not be modified.

The SDT states that the CIP Version 5 Revisions SDT should consider developing guidance documentation around the following areas:

- Low Impact BES Cyber Systems that must comply with a limited number of requirements, all located in CIP-003-5. The only technical requirement is R2, which will be modified during the current drafting activity to add clarity to the requirement. The SDT notes that the CIP Version 5 Revisions SDT should consider developing guidance around how this requirement relates to dispersed generation.
- Any programmable logic device that has the capability to shut down the plant within 15 minutes; and
- Remote access from third party entities into the SCADA systems that control the aggregate capacity of a ~~facility~~Facility should be assessed to determine if there is a need of any additional cyber security policies.

The SDT intends to recommend guidance for those companies that only operate their turbines from one central location. Individual Elements lumped into a BES Cyber System should be addressed. When operations are on a turbine-by-turbine basis, the SDT believes there should not be rigid controls in place. The inability to “swim upstream” should be addressed as well. Further, the guidance intends to address when manufacturers operate or have control of the SCADA environment to conduct troubleshooting and other tasks, and ensure that proper security is in place.

NERC staff has committed to facilitate communication between the SDT and the CIP Version 5 Revisions SDT as appropriate to ensure alignment and to develop language for guidance, coordinated between the two SDTs. *Therefore, the applicability of CIP standards does not need to be changed for dispersed generation resources.*

Appendix A: List of Standards

Appendix B: List of Standards Recommended for Further Review

Standard Number	Status	Further Review by SDT	Regional
BAL-001-1	Subject to Enforcement	No	No
BAL-001-TRE-1	Subject to Enforcement	Yes	Yes
BAL-002-1	Subject to Enforcement	No	No
BAL-002-WECC-2	Subject to Enforcement	No	Yes
BAL-003-0.1b	Subject to Enforcement	No	No
BAL-004-0	Subject to Enforcement	No	No
BAL-004-WECC-02	Subject to Enforcement	No	Yes
BAL-005-0.2b	Subject to Enforcement	No	No
BAL-006-2	Subject to Enforcement	No	No
BAL-502-RFC-02	Subject to Enforcement	No	Yes
CIP-002-3	Subject to Enforcement	No	No
CIP-003-3	Subject to Enforcement	No	No
CIP-004-3a	Subject to Enforcement	No	No
CIP-005-3a	Subject to Enforcement	No	No
CIP-006-3c	Subject to Enforcement	No	No
CIP-007-3a	Subject to Enforcement	No	No
CIP-008-3	Subject to Enforcement	No	No
CIP-009-3	Subject to Enforcement	No	No
COM-001-1.1	Subject to Enforcement	No	No
COM-002-2	Subject to Enforcement	No	No
EOP-001-2.1b	Subject to Enforcement	No	No
EOP-002-3.1	Subject to Enforcement	No	No
EOP-003-2	Subject to Enforcement	No	No
EOP-004-2	Subject to Enforcement	Yes	No
EOP-005-2	Subject to Enforcement	No	No
EOP-006-2	Subject to Enforcement	No	No
EOP-008-1	Subject to Enforcement	No	No
FAC-001-1	Subject to Enforcement	No	No
FAC-002-1	Subject to Enforcement	No	No
FAC-003-3	Subject to Enforcement	No	No
FAC-008-3	Subject to Enforcement	Yes	No
FAC-010-2.1	Subject to Enforcement	No	No
FAC-011-2	Subject to Enforcement	No	No
FAC-013-2	Subject to Enforcement	No	No
FAC-014-2	Subject to Enforcement	No	No
FAC-501-WECC-1	Subject to Enforcement	No	Yes
INT-004-3	Subject to Enforcement	No	No
INT-006-4	Subject to Enforcement	No	No
INT-009-2	Subject to Enforcement	No	No
INT-010-2	Subject to Enforcement	No	No
INT-011-1	Subject to Enforcement	No	No
IRO-001-1.1	Subject to Enforcement	No	No
IRO-002-2	Subject to Enforcement	No	No
IRO-003-2	Subject to Enforcement	No	No
IRO-004-2	Subject to Enforcement	No	No
IRO-005-3.1a	Subject to Enforcement	No	No
IRO-006-5	Subject to Enforcement	No	No
IRO-006-EAST-1	Subject to Enforcement	No	Yes
IRO-006-TRE-1	Subject to Enforcement	No	Yes
IRO-006-WECC-2	Subject to Enforcement	No	Yes
IRO-008-1	Subject to Enforcement	No	No
IRO-009-1	Subject to Enforcement	No	No
IRO-010-1a	Subject to Enforcement	No	No
IRO-014-1	Subject to Enforcement	No	No
IRO-015-1	Subject to Enforcement	No	No
IRO-016-1	Subject to Enforcement	No	No
MOD-001-1a	Subject to Enforcement	No	No
MOD-004-1	Subject to Enforcement	No	No
MOD-008-1	Subject to Enforcement	No	No
MOD-010-0	Subject to Enforcement	No	No

**Note: Make sure
"Appendix A
Source" is correct.
This table will auto-
populate.**

**Zeroes indicate
missing value on
"Appendix A
Source".**

MOD-012-0	Subject to Enforcement	No	No
MOD-016-1.1	Subject to Enforcement	No	No
MOD-017-0.1	Subject to Enforcement	No	No
MOD-018-0	Subject to Enforcement	No	No
MOD-019-0.1	Subject to Enforcement	No	No
MOD-020-0	Subject to Enforcement	No	No
MOD-021-1	Subject to Enforcement	No	No
MOD-026-1	Subject to Enforcement	Yes	No
MOD-027-1	Subject to Enforcement	Yes	No
MOD-028-2	Subject to Enforcement	No	No
MOD-029-1a	Subject to Enforcement	No	No
MOD-030-2	Subject to Enforcement	No	No
NUC-001-2.1	Subject to Enforcement	No	No
PER-001-0.2	Subject to Enforcement	No	No
PER-003-1	Subject to Enforcement	No	No
PER-004-2	Subject to Enforcement	No	No
PER-005-1	Subject to Enforcement	No	No
PRC-001-1.1	Subject to Enforcement	Yes	No
PRC-002-NPCC-01	Subject to Enforcement	No	Yes
PRC-004-2.1a	Subject to Enforcement	Yes	No
PRC-004-WECC-1	Subject to Enforcement	Yes	Yes
PRC-005-1.1b	Subject to Enforcement	Yes	No
PRC-006-1	Subject to Enforcement	No	No
PRC-006-SERC-01	Subject to Enforcement	Yes	Yes
PRC-008-0	Subject to Enforcement	No	No
PRC-010-0	Subject to Enforcement	No	No
PRC-011-0	Subject to Enforcement	No	No
PRC-015-0	Subject to Enforcement	No	No
PRC-016-0.1	Subject to Enforcement	No	No
PRC-017-0	Subject to Enforcement	No	No
PRC-018-1	Subject to Enforcement	No	No
PRC-021-1	Subject to Enforcement	No	No
PRC-022-1	Subject to Enforcement	No	No
PRC-023-3	Subject to Enforcement	No	No
PRC-025-1	Subject to Enforcement	Yes	No
TOP-001-1a	Subject to Enforcement	Yes	No
TOP-002-2.1b	Subject to Enforcement	Yes	No
TOP-003-1	Subject to Enforcement	Yes	No
TOP-004-2	Subject to Enforcement	No	No
TOP-005-2a	Subject to Enforcement	No	No
TOP-006-2	Subject to Enforcement	Yes	No
TOP-007-0	Subject to Enforcement	No	No
TOP-007-WECC-1a	Subject to Enforcement	No	Yes
TOP-008-1	Subject to Enforcement	No	No
TPL-001-0.1	Subject to Enforcement	No	No
TPL-002-0b	Subject to Enforcement	No	No
TPL-003-0b	Subject to Enforcement	No	No
TPL-004-0a	Subject to Enforcement	No	No
VAR-001-4	Subject to Enforcement	No	No
VAR-002-3	Subject to Enforcement	Yes	No
VAR-002-WECC-1	Subject to Enforcement	No	Yes
VAR-501-WECC-1	Subject to Enforcement	No	Yes
BAL-003-1	Subject to Future Enforcement	No	No
CIP-002-5.1	Subject to Future Enforcement	No	No
CIP-003-5	Subject to Future Enforcement	No	No
CIP-004-5.1	Subject to Future Enforcement	No	No
CIP-005-5	Subject to Future Enforcement	No	No
CIP-006-5	Subject to Future Enforcement	No	No
CIP-007-5	Subject to Future Enforcement	No	No
CIP-008-5	Subject to Future Enforcement	No	No
CIP-009-5	Subject to Future Enforcement	No	No

CIP-010-1	Subject to Future Enforcement	No	No
CIP-011-1	Subject to Future Enforcement	No	No
CIP-014-1	Subject to Future Enforcement	No	No
EOP-010-1	Subject to Future Enforcement	No	No
FAC-001-2	Subject to Future Enforcement	No	No
FAC-002-2	Subject to Future Enforcement	No	No
MOD-025-2	Subject to Future Enforcement	Yes	No
MOD-032-1	Subject to Future Enforcement	Yes	No
MOD-033-1	Subject to Future Enforcement	No	No
NUC-001-3	Subject to Future Enforcement	No	No
PER-005-2	Subject to Future Enforcement	No	No
PRC-005-2	Subject to Future Enforcement	Yes	No
PRC-006-NPCC-1	Subject to Future Enforcement	Yes	Yes
PRC-019-1	Subject to Future Enforcement	Yes	No
PRC-024-1	Subject to Future Enforcement	Yes	No
TPL-001-4	Subject to Future Enforcement	No	No
BAL-001-2	Pending Regulatory Approval	No	No
BAL-002-1a	Pending Regulatory Approval	No	No
COM-001-2	Pending Regulatory Approval	No	No
COM-002-4	Pending Regulatory Approval	No	No
MOD-001-2	Pending Regulatory Approval	No	No
MOD-011-0	Pending Regulatory Approval	No	No
MOD-013-1	Pending Regulatory Approval	No	No
MOD-014-0	Pending Regulatory Approval	No	No
MOD-015-0	Pending Regulatory Approval	No	No
MOD-031-1	Pending Regulatory Approval	No	No
PRC-002-1	Pending Regulatory Approval	No	No
PRC-003-1	Pending Regulatory Approval	No	No
PRC-004-3	Pending Regulatory Approval	Yes	No
PRC-005-3	Pending Regulatory Approval	Yes	No
PRC-012-0	Pending Regulatory Approval	No	No
PRC-013-0	Pending Regulatory Approval	No	No
PRC-014-0	Pending Regulatory Approval	No	No
PRC-020-1	Pending Regulatory Approval	No	No
TOP-006-3	Pending Regulatory Approval	Yes	No
TPL-001-3	Pending Regulatory Approval	No	No
TPL-002-2b	Pending Regulatory Approval	No	No
TPL-003-2a	Pending Regulatory Approval	No	No
TPL-004-2	Pending Regulatory Approval	No	No
TPL-005-0	Pending Regulatory Approval	No	No
CIP-002-3b	Pending Regulatory Filing	No	No
CIP-003-3a	Pending Regulatory Filing	No	No
CIP-007-3b	Pending Regulatory Filing	No	No
COM-002-2a	Pending Regulatory Filing	No	No
IRO-001-4	Pending Regulatory Filing	No	No
IRO-002-4	Pending Regulatory Filing	No	No
IRO-008-2	Pending Regulatory Filing	No	No
IRO-010-2	Pending Regulatory Filing	No	No
IRO-014-3	Pending Regulatory Filing	No	No
IRO-017-1	Pending Regulatory Filing	0	No
TOP-002-4	Pending Regulatory Filing	Yes	No
TOP-003-3	Pending Regulatory Filing	Yes	No
IRO-001-3	*See Project 2014-03	Yes	No
IRO-002-3	*See Project 2014-03	No	No
IRO-005-4	*See Project 2014-03	Yes	No
IRO-014-2	*See Project 2014-03	No	No
PRC-001-2	*See Project 2014-03	Yes	No
TOP-001-2	*See Project 2014-03	Yes	No
TOP-002-3	*See Project 2014-03	Yes	No
TOP-003-2	*See Project 2014-03	Yes	No
MOD-024-1	Designated for Retirement	No	No
MOD-025-1	Designated for Retirement	No	No

Status	Number of Standards	Number of Standards to be Addressed (Standard, RSAW, Guidance or Further Review)
NERC Standards	168	24
Subject to Enforcement	98	13
Subject to Future Enforcement	24	5
Pending Regulatory Approval	24	3
Pending Regulatory Filing	12	3
Designated for Retirement	2	0
Proposed for Remand	8	0
Region-specific Standards (*Out of Scope)	15	4
Subject to Enforcement	14	3
Subject to Future Enforcement	1	1
Pending Regulatory Approval	0	0
Grand Total	183	28

Note: Make sure "Appendix A Source" is complete. This table will auto-populate.

Priority	Standard Number	Area To Change	Target Applicability
High	PRC-004-2.1a	Applicability Section	Misoperations affecting >75MVA
High	PRC-004-3	Applicability Section	Misoperations affecting >75MVA
High	PRC-005-1.1b	Guidance	Point where aggregates to >75MVA
High	PRC-005-2	Applicability Section	Point where aggregates to >75MVA
High	PRC-005-3	Applicability Section	Point where aggregates to >75MVA
High	VAR-002-3	Applicability Section& Footnote	Aggregate Facility Level for Voltage Control; Transmission voltage GSUs
Medium	EOP-004-2	No Action	NA
Medium	FAC-008-3	Guidance	Individual BES Resources /Elements to Include Aggregating Equipment
Medium	IRO-017-1	TBD	TBD
Medium	MOD-025-2	No Action	NA
Medium	MOD-026-1	No Action	NA
Medium	MOD-027-1	No Action	NA
Medium	MOD-032-1	No Action	NA
Medium	PRC-001-1.1	Applicability Section	Aggregate Facility Level
Medium	PRC-019-1	Applicability Section	Individual BES Resources/Elements
Medium	PRC-024-1	By Requirement	Individual BES Resources /Elements to Include Aggregating Equipment
Medium	PRC-025-1	Guidance	Individual BES Resources /Elements to Include Aggregating Equipment
Medium	TOP-001-1a	No Action	NA
Medium	TOP-002-2.1b	Applicability Section	Aggregate Facility Level
Medium	TOP-002-4	TBD	TBD
Medium	TOP-003-1	By Requirement	Aggregate Facility Level
Medium	TOP-003-3	TBD	TBD
Medium	TOP-006-2	No Action	NA
Medium	TOP-006-3	TBD	TBD
Low	BAL-001-TRE-1	Applicability Section	Aggregate Facility Level
Low	PRC-004-WECC-1	Applicability Section	Point where aggregates to >75MVA
Low	PRC-006-NPCC-1	By Requirement	Individual BES Resources/Elements
Low	PRC-006-SERC-01	By Requirement	Individual BES Resources/Elements
0	0	0	0
0	0	0	0
0	0	v cells. Ensure rest aligns with the pap	0
0	0	0	0
0	0	0	0
0	0	0	0

Note: Make sure "Appendix B Source" is correct. This table will auto-populate.

Zeros indicate missing value on "Appendix B Source".

Status	Standard	FURTHER REVIEW	REG	Title	ste	reg	ste no reg	ste reg	stfe	reg	sfte no reg	sfte reg	pra	reg	pra no reg	pra reg	prf	reg	prf no reg	prf reg	rem	reg	rem no reg	rem reg	ret	reg	ret no reg	ret reg	total	
Subject to Enforcement	BAL-001-1	No		Real Power Balancing Control Performance	1	0	1	0	0	0	0	0	0	0	0	0	0	0	0	0	0	0	0	0	0	0	0	0	0	1
Subject to Enforcement	BAL-001-TRE-1	Yes	R	Primary Frequency Response in the ERCOT Region	1	1	0	1	0	1	0	0	0	1	0	0	0	1	0	0	0	1	0	0	0	1	0	0	0	1
Subject to Enforcement	BAL-002-1	No		Disturbance Control Performance	1	0	1	0	0	0	0	0	0	0	0	0	0	0	0	0	0	0	0	0	0	0	0	0	0	1
Subject to Enforcement	BAL-002-WECC-2	No	R	Contingency Reserve	1	1	0	1	0	1	0	0	1	0	0	0	0	1	0	0	0	1	0	0	0	1	0	0	0	1
Subject to Enforcement	BAL-003-0.1b	No		Frequency Response and Bias	1	0	1	0	0	0	0	0	0	0	0	0	0	0	0	0	0	0	0	0	0	0	0	0	0	1
Subject to Enforcement	BAL-004-0	No		Time Error Correction	1	0	1	0	0	0	0	0	0	0	0	0	0	0	0	0	0	0	0	0	0	0	0	0	0	1
Subject to Enforcement	BAL-004-WECC-02	No	R	Automatic Time Error Correction (ATEC)	1	1	0	1	0	1	0	0	1	0	0	0	0	1	0	0	0	1	0	0	0	1	0	0	0	1
Subject to Enforcement	BAL-005-0.2b	No		Automatic Generation Control	1	0	1	0	0	0	0	0	0	0	0	0	0	0	0	0	0	0	0	0	0	0	0	0	0	1
Subject to Enforcement	BAL-006-2	No		Inadvertent Interchange	1	0	1	0	0	0	0	0	0	0	0	0	0	0	0	0	0	0	0	0	0	0	0	0	0	1
Subject to Enforcement	BAL-502-RFC-02	No	R	Planning Resource Adequacy Analysis, Assessment and Documentation	1	1	0	1	0	1	0	0	1	0	0	0	0	1	0	0	0	1	0	0	0	1	0	0	0	1
Subject to Enforcement	CIP-002-3	No		Cyber Security — Critical Cyber Asset Identification	1	0	1	0	0	0	0	0	0	0	0	0	0	0	0	0	0	0	0	0	0	0	0	0	0	1
Subject to Enforcement	CIP-003-3	No		Cyber Security — Security Management Controls	1	0	1	0	0	0	0	0	0	0	0	0	0	0	0	0	0	0	0	0	0	0	0	0	0	1
Subject to Enforcement	CIP-004-3a	No		Cyber Security — Personnel & Training	1	0	1	0	0	0	0	0	0	0	0	0	0	0	0	0	0	0	0	0	0	0	0	0	0	1
Subject to Enforcement	CIP-005-3a	No		Cyber Security — Electronic Security Perimeter(s)	1	0	1	0	0	0	0	0	0	0	0	0	0	0	0	0	0	0	0	0	0	0	0	0	0	1
Subject to Enforcement	CIP-006-3c	No		Cyber Security — Physical Security of Critical Cyber Assets	1	0	1	0	0	0	0	0	0	0	0	0	0	0	0	0	0	0	0	0	0	0	0	0	0	1
Subject to Enforcement	CIP-007-3a	No		Cyber Security — Systems Security Management	1	0	1	0	0	0	0	0	0	0	0	0	0	0	0	0	0	0	0	0	0	0	0	0	0	1
Subject to Enforcement	CIP-008-3	No		Cyber Security — Incident Reporting and Response Planning	1	0	1	0	0	0	0	0	0	0	0	0	0	0	0	0	0	0	0	0	0	0	0	0	0	1
Subject to Enforcement	CIP-009-3	No		Cyber Security — Recovery Plans for Critical Cyber Assets	1	0	1	0	0	0	0	0	0	0	0	0	0	0	0	0	0	0	0	0	0	0	0	0	0	1
Subject to Enforcement	COM-001-1.1	No		Telecommunications	1	0	1	0	0	0	0	0	0	0	0	0	0	0	0	0	0	0	0	0	0	0	0	0	0	1
Subject to Enforcement	COM-002-2	No		Communications and Coordination	1	0	1	0	0	0	0	0	0	0	0	0	0	0	0	0	0	0	0	0	0	0	0	0	0	1
Subject to Enforcement	EOP-001-2.1b	No		Emergency Operations Planning	1	0	1	0	0	0	0	0	0	0	0	0	0	0	0	0	0	0	0	0	0	0	0	0	0	1
Subject to Enforcement	EOP-002-3.1	No		Capacity and Energy Emergencies	1	0	1	0	0	0	0	0	0	0	0	0	0	0	0	0	0	0	0	0	0	0	0	0	0	1
Subject to Enforcement	EOP-003-2	No		Load Shedding Plans	1	0	1	0	0	0	0	0	0	0	0	0	0	0	0	0	0	0	0	0	0	0	0	0	0	1
Subject to Enforcement	EOP-004-2	Yes		Event Reporting	1	0	1	0	0	0	0	0	0	0	0	0	0	0	0	0	0	0	0	0	0	0	0	0	0	1
Subject to Enforcement	EOP-005-2	No		System Restoration from Blackstart Resources	1	0	1	0	0	0	0	0	0	0	0	0	0	0	0	0	0	0	0	0	0	0	0	0	0	1
Subject to Enforcement	EOP-006-2	No		System Restoration Coordination	1	0	1	0	0	0	0	0	0	0	0	0	0	0	0	0	0	0	0	0	0	0	0	0	0	1
Subject to Enforcement	EOP-008-1	No		Loss of Control Center Functionality	1	0	1	0	0	0	0	0	0	0	0	0	0	0	0	0	0	0	0	0	0	0	0	0	0	1
Subject to Enforcement	FAC-001-1	No		Facility Connection Requirements	1	0	1	0	0	0	0	0	0	0	0	0	0	0	0	0	0	0	0	0	0	0	0	0	0	1
Subject to Enforcement	FAC-002-1	No		Coordination of Plans For New Generation, Transmission, and End-User Facilities	1	0	1	0	0	0	0	0	0	0	0	0	0	0	0	0	0	0	0	0	0	0	0	0	0	1
Subject to Enforcement	FAC-003-3	No		Transmission Vegetation Management	1	0	1	0	0	0	0	0	0	0	0	0	0	0	0	0	0	0	0	0	0	0	0	0	0	1
Subject to Enforcement	FAC-008-3	Yes		Facility Ratings	1	0	1	0	0	0	0	0	0	0	0	0	0	0	0	0	0	0	0	0	0	0	0	0	0	1
Subject to Enforcement	FAC-010-2.1	No		System Operating Limits Methodology for the Planning Horizon	1	0	1	0	0	0	0	0	0	0	0	0	0	0	0	0	0	0	0	0	0	0	0	0	0	1
Subject to Enforcement	FAC-011-2	No		System Operating Limits Methodology for the Operations Horizon	1	0	1	0	0	0	0	0	0	0	0	0	0	0	0	0	0	0	0	0	0	0	0	0	0	1
Subject to Enforcement	FAC-013-2	No		Assessment of Transfer Capability for the Near-Term Transmission Planning Horizon	1	0	1	0	0	0	0	0	0	0	0	0	0	0	0	0	0	0	0	0	0	0	0	0	0	1
Subject to Enforcement	FAC-014-2	No		Establish and Communicate System Operating Limits	1	0	1	0	0	0	0	0	0	0	0	0	0	0	0	0	0	0	0	0	0	0	0	0	0	1
Subject to Enforcement	FAC-501-WECC-1	No	R	Transmission Maintenance	1	1	0	1	0	1	0	0	1	0	0	0	0	1	0	0	0	1	0	0	0	1	0	0	0	1
Subject to Enforcement	INT-004-3	No		Dynamic Transfers	1	0	1	0	0	0	0	0	0	0	0	0	0	0	0	0	0	0	0	0	0	0	0	0	0	1
Subject to Enforcement	INT-006-4	No		Evaluation of Interchange Transactions	1	0	1	0	0	0	0	0	0	0	0	0	0	0	0	0	0	0	0	0	0	0	0	0	0	1
Subject to Enforcement	INT-009-2	No		Implementation of Interchange	1	0	1	0	0	0	0	0	0	0	0	0	0	0	0	0	0	0	0	0	0	0	0	0	0	1
Subject to Enforcement	INT-010-2	No		Interchange Initiation and Modification for Reliability	1	0	1	0	0	0	0	0	0	0	0	0	0	0	0	0	0	0	0	0	0	0	0	0	0	1
Subject to Enforcement	INT-011-1	No		Intra-Balancing Authority Transaction Identification	1	0	1	0	0	0	0	0	0	0	0	0	0	0	0	0	0	0	0	0	0	0	0	0	0	1
Subject to Enforcement	IRO-001-1.1	No		Reliability Coordination — Responsibilities and Authorities	1	0	1	0	0	0	0	0	0	0	0	0	0	0	0	0	0	0	0	0	0	0	0	0	0	1
Subject to Enforcement	IRO-002-2	No		Reliability Coordination — Facilities	1	0	1	0	0	0	0	0	0	0	0	0	0	0	0	0	0	0	0	0	0	0	0	0	0	1
Subject to Enforcement	IRO-003-2	No		Reliability Coordination — Wide-Area View	1	0	1	0	0	0	0	0	0	0	0	0	0	0	0	0	0	0	0	0	0	0	0	0	0	1
Subject to Enforcement	IRO-004-2	No		Reliability Coordination — Operations Planning	1	0	1	0	0	0	0	0	0	0	0	0	0	0	0	0	0	0	0	0	0	0	0	0	0	1
Subject to Enforcement	IRO-005-3.1a	No		Reliability Coordination — Current Day Operations	1	0	1	0	0	0	0	0	0	0	0	0	0	0	0	0	0	0	0	0	0	0	0	0	0	1
Subject to Enforcement	IRO-006-5	No		Reliability Coordination — Transmission Loading Relief (TLR)	1	0	1	0	0	0	0	0	0	0	0	0	0	0	0	0	0	0	0	0	0	0	0	0	0	1
Subject to Enforcement	IRO-006-EAST-1	No	R	Transmission Loading Relief Procedure for the Eastern Interconnection	1	1	0	1	0	1	0	0	1	0	0	0	0	1	0	0	0	1	0	0	0	1	0	0	0	1
Subject to Enforcement	IRO-006-TRE-1	No	R	IROL and SOL Mitigation in the ERCOT Region	1	1	0	1	0	1	0	0	1	0	0	0	0	1	0	0	0	1	0	0	0	1	0	0	0	1
Subject to Enforcement	IRO-006-WECC-2	No	R	Qualified Transfer Path Unscheduled Flow (USF) Relief	1	1	0	1	0	1	0	0	1	0	0	0	0	1	0	0	0	1	0	0	0	1	0	0	0	1
Subject to Enforcement	IRO-008-1	No		Reliability Coordinator Operational Analyses and Real-time Assessments	1	0	1	0	0	0	0	0	0	0	0	0	0	0	0	0	0	0	0	0	0	0	0	0	0	1
Subject to Enforcement	IRO-009-1	No		Reliability Coordinator Actions to Operate Within IROLs	1	0	1																							

Standard Number	Status	Further Review by SDT	Regional
BAL-001-1	Subject to Enforcement	No	No
BAL-001-TRE-1	Subject to Enforcement	Yes	Yes
BAL-002-1	Subject to Enforcement	No	No
BAL-002-WECC-2	Subject to Enforcement	No	Yes
BAL-003-0.1b	Subject to Enforcement	No	No
BAL-004-0	Subject to Enforcement	No	No
BAL-004-WECC-02	Subject to Enforcement	No	Yes
BAL-005-0.2b	Subject to Enforcement	No	No
BAL-006-2	Subject to Enforcement	No	No
BAL-502-RFC-02	Subject to Enforcement	No	Yes
CIP-002-3	Subject to Enforcement	No	No
CIP-003-3	Subject to Enforcement	No	No
CIP-004-3a	Subject to Enforcement	No	No
CIP-005-3a	Subject to Enforcement	No	No
CIP-006-3c	Subject to Enforcement	No	No
CIP-007-3a	Subject to Enforcement	No	No
CIP-008-3	Subject to Enforcement	No	No
CIP-009-3	Subject to Enforcement	No	No
COM-001-1.1	Subject to Enforcement	No	No
COM-002-2	Subject to Enforcement	No	No
EOP-001-2.1b	Subject to Enforcement	No	No
EOP-002-3.1	Subject to Enforcement	No	No
EOP-003-2	Subject to Enforcement	No	No
EOP-004-2	Subject to Enforcement	Yes	No
EOP-005-2	Subject to Enforcement	No	No
EOP-006-2	Subject to Enforcement	No	No
EOP-008-1	Subject to Enforcement	No	No
FAC-001-1	Subject to Enforcement	No	No
FAC-002-1	Subject to Enforcement	No	No
FAC-003-3	Subject to Enforcement	No	No
FAC-008-3	Subject to Enforcement	Yes	No
FAC-010-2.1	Subject to Enforcement	No	No
FAC-011-2	Subject to Enforcement	No	No
FAC-013-2	Subject to Enforcement	No	No
FAC-014-2	Subject to Enforcement	No	No
FAC-501-WECC-1	Subject to Enforcement	No	Yes
INT-004-3	Subject to Enforcement	No	No
INT-006-4	Subject to Enforcement	No	No
INT-009-2	Subject to Enforcement	No	No
INT-010-2	Subject to Enforcement	No	No
INT-011-1	Subject to Enforcement	No	No
IRO-001-1.1	Subject to Enforcement	No	No
IRO-002-2	Subject to Enforcement	No	No
IRO-003-2	Subject to Enforcement	No	No
IRO-004-2	Subject to Enforcement	No	No
IRO-005-3.1a	Subject to Enforcement	No	No
IRO-006-5	Subject to Enforcement	No	No
IRO-006-EAST-1	Subject to Enforcement	No	Yes
IRO-006-TRE-1	Subject to Enforcement	No	Yes
IRO-006-WECC-2	Subject to Enforcement	No	Yes
IRO-008-1	Subject to Enforcement	No	No
IRO-009-1	Subject to Enforcement	No	No
IRO-010-1a	Subject to Enforcement	No	No
IRO-014-1	Subject to Enforcement	No	No
IRO-015-1	Subject to Enforcement	No	No
IRO-016-1	Subject to Enforcement	No	No
MOD-001-1a	Subject to Enforcement	No	No
MOD-004-1	Subject to Enforcement	No	No
MOD-008-1	Subject to Enforcement	No	No
MOD-010-0	Subject to Enforcement	No	No

**Note: Make sure
"Appendix A
Source" is correct.
This table will auto-
populate.**

**Zeroes indicate
missing value on
"Appendix A
Source".**

MOD-012-0	Subject to Enforcement	No	No
MOD-016-1.1	Subject to Enforcement	No	No
MOD-017-0.1	Subject to Enforcement	No	No
MOD-018-0	Subject to Enforcement	No	No
MOD-019-0.1	Subject to Enforcement	No	No
MOD-020-0	Subject to Enforcement	No	No
MOD-021-1	Subject to Enforcement	No	No
MOD-026-1	Subject to Enforcement	Yes	No
MOD-027-1	Subject to Enforcement	Yes	No
MOD-028-2	Subject to Enforcement	No	No
MOD-029-1a	Subject to Enforcement	No	No
MOD-030-2	Subject to Enforcement	No	No
NUC-001-2.1	Subject to Enforcement	No	No
PER-001-0.2	Subject to Enforcement	No	No
PER-003-1	Subject to Enforcement	No	No
PER-004-2	Subject to Enforcement	No	No
PER-005-1	Subject to Enforcement	No	No
PRC-001-1.1	Subject to Enforcement	Yes	No
PRC-002-NPCC-01	Subject to Enforcement	No	Yes
PRC-004-2.1a	Subject to Enforcement	Yes	No
PRC-004-WECC-1	Subject to Enforcement	Yes	Yes
PRC-005-1.1b	Subject to Enforcement	Yes	No
PRC-006-1	Subject to Enforcement	No	No
PRC-006-SERC-01	Subject to Enforcement	Yes	Yes
PRC-008-0	Subject to Enforcement	No	No
PRC-010-0	Subject to Enforcement	No	No
PRC-011-0	Subject to Enforcement	No	No
PRC-015-0	Subject to Enforcement	No	No
PRC-016-0.1	Subject to Enforcement	No	No
PRC-017-0	Subject to Enforcement	No	No
PRC-018-1	Subject to Enforcement	No	No
PRC-021-1	Subject to Enforcement	No	No
PRC-022-1	Subject to Enforcement	No	No
PRC-023-3	Subject to Enforcement	No	No
PRC-025-1	Subject to Enforcement	Yes	No
TOP-001-1a	Subject to Enforcement	Yes	No
TOP-002-2.1b	Subject to Enforcement	Yes	No
TOP-003-1	Subject to Enforcement	Yes	No
TOP-004-2	Subject to Enforcement	No	No
TOP-005-2a	Subject to Enforcement	No	No
TOP-006-2	Subject to Enforcement	Yes	No
TOP-007-0	Subject to Enforcement	No	No
TOP-007-WECC-1a	Subject to Enforcement	No	Yes
TOP-008-1	Subject to Enforcement	No	No
TPL-001-0.1	Subject to Enforcement	No	No
TPL-002-0b	Subject to Enforcement	No	No
TPL-003-0b	Subject to Enforcement	No	No
TPL-004-0a	Subject to Enforcement	No	No
VAR-001-4	Subject to Enforcement	No	No
VAR-002-3	Subject to Enforcement	Yes	No
VAR-002-WECC-1	Subject to Enforcement	No	Yes
VAR-501-WECC-1	Subject to Enforcement	No	Yes
BAL-003-1	Subject to Future Enforcement	No	No
CIP-002-5.1	Subject to Future Enforcement	No	No
CIP-003-5	Subject to Future Enforcement	No	No
CIP-004-5.1	Subject to Future Enforcement	No	No
CIP-005-5	Subject to Future Enforcement	No	No
CIP-006-5	Subject to Future Enforcement	No	No
CIP-007-5	Subject to Future Enforcement	No	No
CIP-008-5	Subject to Future Enforcement	No	No
CIP-009-5	Subject to Future Enforcement	No	No

CIP-010-1	Subject to Future Enforcement	No	No
CIP-011-1	Subject to Future Enforcement	No	No
CIP-014-1	Subject to Future Enforcement	No	No
EOP-010-1	Subject to Future Enforcement	No	No
FAC-001-2	Subject to Future Enforcement	No	No
FAC-002-2	Subject to Future Enforcement	No	No
MOD-025-2	Subject to Future Enforcement	Yes	No
MOD-032-1	Subject to Future Enforcement	Yes	No
MOD-033-1	Subject to Future Enforcement	No	No
NUC-001-3	Subject to Future Enforcement	No	No
PER-005-2	Subject to Future Enforcement	No	No
PRC-005-2	Subject to Future Enforcement	Yes	No
PRC-006-NPCC-1	Subject to Future Enforcement	Yes	Yes
PRC-019-1	Subject to Future Enforcement	Yes	No
PRC-024-1	Subject to Future Enforcement	Yes	No
TPL-001-4	Subject to Future Enforcement	No	No
BAL-001-2	Pending Regulatory Approval	No	No
BAL-002-1a	Pending Regulatory Approval	No	No
COM-001-2	Pending Regulatory Approval	No	No
COM-002-4	Pending Regulatory Approval	No	No
MOD-001-2	Pending Regulatory Approval	No	No
MOD-011-0	Pending Regulatory Approval	No	No
MOD-013-1	Pending Regulatory Approval	No	No
MOD-014-0	Pending Regulatory Approval	No	No
MOD-015-0	Pending Regulatory Approval	No	No
MOD-031-1	Pending Regulatory Approval	No	No
PRC-002-1	Pending Regulatory Approval	No	No
PRC-003-1	Pending Regulatory Approval	No	No
PRC-004-3	Pending Regulatory Approval	Yes	No
PRC-005-3	Pending Regulatory Approval	Yes	No
PRC-012-0	Pending Regulatory Approval	No	No
PRC-013-0	Pending Regulatory Approval	No	No
PRC-014-0	Pending Regulatory Approval	No	No
PRC-020-1	Pending Regulatory Approval	No	No
TOP-006-3	Pending Regulatory Approval	Yes	No
TPL-001-3	Pending Regulatory Approval	No	No
TPL-002-2b	Pending Regulatory Approval	No	No
TPL-003-2a	Pending Regulatory Approval	No	No
TPL-004-2	Pending Regulatory Approval	No	No
TPL-005-0	Pending Regulatory Approval	No	No
CIP-002-3b	Pending Regulatory Filing	No	No
CIP-003-3a	Pending Regulatory Filing	No	No
CIP-007-3b	Pending Regulatory Filing	No	No
COM-002-2a	Pending Regulatory Filing	No	No
IRO-001-4	Pending Regulatory Filing	No	No
IRO-002-4	Pending Regulatory Filing	No	No
IRO-008-2	Pending Regulatory Filing	No	No
IRO-010-2	Pending Regulatory Filing	No	No
IRO-014-3	Pending Regulatory Filing	No	No
IRO-017-1	Pending Regulatory Filing	0	No
TOP-002-4	Pending Regulatory Filing	Yes	No
TOP-003-3	Pending Regulatory Filing	Yes	No
IRO-001-3	*See Project 2014-03	Yes	No
IRO-002-3	*See Project 2014-03	No	No
IRO-005-4	*See Project 2014-03	Yes	No
IRO-014-2	*See Project 2014-03	No	No
PRC-001-2	*See Project 2014-03	Yes	No
TOP-001-2	*See Project 2014-03	Yes	No
TOP-002-3	*See Project 2014-03	Yes	No
TOP-003-2	*See Project 2014-03	Yes	No
MOD-024-1	Designated for Retirement	No	No
MOD-025-1	Designated for Retirement	No	No

Status	Number of Standards	Number of Standards to be Addressed (Standard, RSAW, Guidance or Further Review)
NERC Standards	168	24
Subject to Enforcement	98	13
Subject to Future Enforcement	24	5
Pending Regulatory Approval	24	3
Pending Regulatory Filing	12	3
Designated for Retirement	2	0
Proposed for Remand	8	0
Region-specific Standards (*Out of Scope)	15	4
Subject to Enforcement	14	3
Subject to Future Enforcement	1	1
Pending Regulatory Approval	0	0
Grand Total	183	28

Note: Make sure "Appendix A Source" is complete. This table will auto-populate.

Priority	Standard Number	Area To Change	Target Applicability
High	PRC-004-2.1a	Applicability Section	Misoperations affecting >75MVA
High	PRC-004-3	Applicability Section	Misoperations affecting >75MVA
High	PRC-005-1.1b	Guidance	Point where aggregates to >75MVA
High	PRC-005-2	Applicability Section	Point where aggregates to >75MVA
High	PRC-005-3	Applicability Section	Point where aggregates to >75MVA
High	VAR-002-3	Applicability Section& Footnote	Aggregate Facility Level for Voltage Control; Transmission voltage GSUs
Medium	EOP-004-2	No Action	NA
Medium	FAC-008-3	Guidance	Individual BES Resources /Elements to Include Aggregating Equipment
Medium	IRO-017-1	TBD	TBD
Medium	MOD-025-2	No Action	NA
Medium	MOD-026-1	No Action	NA
Medium	MOD-027-1	No Action	NA
Medium	MOD-032-1	No Action	NA
Medium	PRC-001-1.1	Applicability Section	Aggregate Facility Level
Medium	PRC-019-1	Applicability Section	Individual BES Resources/Elements
Medium	PRC-024-1	By Requirement	Individual BES Resources /Elements to Include Aggregating Equipment
Medium	PRC-025-1	Guidance	Individual BES Resources /Elements to Include Aggregating Equipment
Medium	TOP-001-1a	No Action	NA
Medium	TOP-002-2.1b	Applicability Section	Aggregate Facility Level
Medium	TOP-002-4	TBD	TBD
Medium	TOP-003-1	By Requirement	Aggregate Facility Level
Medium	TOP-003-3	TBD	TBD
Medium	TOP-006-2	No Action	NA
Medium	TOP-006-3	TBD	TBD
Low	BAL-001-TRE-1	Applicability Section	Aggregate Facility Level
Low	PRC-004-WECC-1	Applicability Section	Point where aggregates to >75MVA
Low	PRC-006-NPCC-1	By Requirement	Individual BES Resources/Elements
Low	PRC-006-SERC-01	By Requirement	Individual BES Resources/Elements
0	0	0	0
0	0	0	0
0	0	v cells. Ensure rest aligns with the pap	0
0	0	0	0
0	0	0	0
0	0	0	0

Note: Make sure "Appendix B Source" is correct. This table will auto-populate.

Zeros indicate missing value on "Appendix B Source".

Priority	Status	Standard		Reg	Title	ste	reg	te	no	re	ste	reg	te	no	rs	fte	reg	te	no	rs	fte	reg	pra	reg	ra	no	re	pra	reg	prf	reg	prf	no	reg	prf	reg	rem	reg	em	no	rer	reg	ret	reg	et	no	re	ret	reg	total			
High	Subject to Enforcement	PRC-004-2.1a	Applicability Section		Misoperations affecting >75MVA	1	0	1	0	0	0	0	0	0	0	0	0	0	0	0	0	0	0	0	0	0	0	0	0	0	0	0	0	0	0	0	0	0	0	0	0	0	0	0	0	0	0	1					
High	Pending Regulatory Approval	PRC-004-3	Applicability Section		Misoperations affecting >75MVA	0	0	0	0	0	0	0	0	0	0	0	0	0	0	0	0	0	0	0	1	0	1	0	0	0	0	0	0	0	0	0	0	0	0	0	0	0	0	0	0	0	0	0	0	1			
High	Subject to Enforcement	PRC-005-1.1b	Guidance		Point where aggregates to >75MVA	1	0	1	0	0	0	0	0	0	0	0	0	0	0	0	0	0	0	0	0	0	0	0	0	0	0	0	0	0	0	0	0	0	0	0	0	0	0	0	0	0	0	0	1				
High	Subject to Future Enforcement	PRC-005-2	Applicability Section		Point where aggregates to >75MVA	0	0	0	0	1	0	0	1	0	0	0	0	0	0	0	0	0	0	0	0	0	0	0	0	0	0	0	0	0	0	0	0	0	0	0	0	0	0	0	0	0	0	0	1				
High	Pending Regulatory Approval	PRC-005-3	Applicability Section		Point where aggregates to >75MVA	0	0	0	0	0	0	0	0	0	0	0	0	0	0	0	0	0	0	0	0	0	0	0	0	0	0	0	0	0	0	0	0	0	0	0	0	0	0	0	0	0	0	0	1				
High	Subject to Enforcement	VAR-002-3	Applicability Section& Footnote		Aggregate Facility Level for Voltage Control; Transmission voltage GSUs	1	0	1	0	0	0	0	0	0	0	0	0	0	0	0	0	0	0	0	0	0	0	0	0	0	0	0	0	0	0	0	0	0	0	0	0	0	0	0	0	0	0	0	1				
Medium	Subject to Enforcement	EOP-004-2	No Action		NA	1	0	1	0	0	0	0	0	0	0	0	0	0	0	0	0	0	0	0	0	0	0	0	0	0	0	0	0	0	0	0	0	0	0	0	0	0	0	0	0	0	0	0	1				
Medium	Subject to Enforcement	FAC-008-3	Guidance		Individual BES Resources /Elements to Include Aggregating Equipment	1	0	1	0	0	0	0	0	0	0	0	0	0	0	0	0	0	0	0	0	0	0	0	0	0	0	0	0	0	0	0	0	0	0	0	0	0	0	0	0	0	0	0	1				
Medium	Pending Regulatory Filing	IRO-017-1	TBD		TBD	0	0	0	0	0	0	0	0	0	0	0	0	0	0	0	0	0	0	0	0	0	0	0	0	0	0	0	0	0	0	0	0	0	0	0	0	0	0	0	0	0	0	0	1				
Medium	Subject to Future Enforcement	MOD-025-2	No Action		NA	0	0	0	0	1	0	0	1	0	0	0	0	0	0	0	0	0	0	0	0	0	0	0	0	0	0	0	0	0	0	0	0	0	0	0	0	0	0	0	0	0	0	0	0	1			
Medium	Subject to Enforcement	MOD-026-1	No Action		NA	1	0	1	0	0	0	0	0	0	0	0	0	0	0	0	0	0	0	0	0	0	0	0	0	0	0	0	0	0	0	0	0	0	0	0	0	0	0	0	0	0	0	0	0	1			
Medium	Subject to Enforcement	MOD-027-1	No Action		NA	1	0	1	0	0	0	0	0	0	0	0	0	0	0	0	0	0	0	0	0	0	0	0	0	0	0	0	0	0	0	0	0	0	0	0	0	0	0	0	0	0	0	0	0	1			
Medium	Subject to Future Enforcement	MOD-032-1	No Action		NA	0	0	0	0	1	0	0	1	0	0	0	0	0	0	0	0	0	0	0	0	0	0	0	0	0	0	0	0	0	0	0	0	0	0	0	0	0	0	0	0	0	0	0	0	1			
Medium	Subject to Enforcement	PRC-001-1.1	Applicability Section		Aggregate Facility Level	1	0	1	0	0	0	0	0	0	0	0	0	0	0	0	0	0	0	0	0	0	0	0	0	0	0	0	0	0	0	0	0	0	0	0	0	0	0	0	0	0	0	0	0	1			
Medium	Subject to Future Enforcement	PRC-019-1	Applicability Section		Individual BES Resources/Elements	0	0	0	0	1	0	0	1	0	0	0	0	0	0	0	0	0	0	0	0	0	0	0	0	0	0	0	0	0	0	0	0	0	0	0	0	0	0	0	0	0	0	0	0	0	1		
Medium	Subject to Future Enforcement	PRC-024-1	By Requirement		Individual BES Resources /Elements to Include Aggregating Equipment	0	0	0	0	1	0	0	1	0	0	0	0	0	0	0	0	0	0	0	0	0	0	0	0	0	0	0	0	0	0	0	0	0	0	0	0	0	0	0	0	0	0	0	0	0	1		
Medium	Subject to Enforcement	PRC-025-1	Guidance		Individual BES Resources /Elements to Include Aggregating Equipment	1	0	1	0	0	0	0	0	0	0	0	0	0	0	0	0	0	0	0	0	0	0	0	0	0	0	0	0	0	0	0	0	0	0	0	0	0	0	0	0	0	0	0	0	0	1		
Medium	Subject to Enforcement	TOP-001-1a	No Action		NA	1	0	1	0	0	0	0	0	0	0	0	0	0	0	0	0	0	0	0	0	0	0	0	0	0	0	0	0	0	0	0	0	0	0	0	0	0	0	0	0	0	0	0	0	0	0	1	
Medium	Subject to Enforcement	TOP-002-2.1b	Applicability Section		Aggregate Facility Level	1	0	1	0	0	0	0	0	0	0	0	0	0	0	0	0	0	0	0	0	0	0	0	0	0	0	0	0	0	0	0	0	0	0	0	0	0	0	0	0	0	0	0	0	0	1		
Medium	Pending Regulatory Filing	TOP-002-4	TBD		TBD	0	0	0	0	0	0	0	0	0	0	0	0	0	0	0	0	0	0	0	0	0	0	0	0	0	0	0	0	0	0	0	0	0	0	0	0	0	0	0	0	0	0	0	0	0	1		
Medium	Subject to Enforcement	TOP-003-1	By Requirement		Aggregate Facility Level	1	0	1	0	0	0	0	0	0	0	0	0	0	0	0	0	0	0	0	0	0	0	0	0	0	0	0	0	0	0	0	0	0	0	0	0	0	0	0	0	0	0	0	0	0	0	1	
Medium	Pending Regulatory Filing	TOP-003-3	TBD		TBD	0	0	0	0	0	0	0	0	0	0	0	0	0	0	0	0	0	0	0	0	0	0	0	0	0	0	0	0	0	0	0	0	0	0	0	0	0	0	0	0	0	0	0	0	0	0	1	
Medium	Subject to Enforcement	TOP-006-2	No Action		NA	1	0	1	0	0	0	0	0	0	0	0	0	0	0	0	0	0	0	0	0	0	0	0	0	0	0	0	0	0	0	0	0	0	0	0	0	0	0	0	0	0	0	0	0	0	0	1	
Medium	Pending Regulatory Approval	TOP-006-3	TBD		TBD	0	0	0	0	0	0	0	0	0	0	0	0	0	0	0	0	0	0	0	0	0	0	0	0	0	0	0	0	0	0	0	0	0	0	0	0	0	0	0	0	0	0	0	0	0	0	1	
Low	Subject to Enforcement	BAL-001-TRE-1	Applicability Section	R	Aggregate Facility Level	1	1	0	1	0	1	0	0	0	0	1	0	0	0	0	1	0	0	0	0	0	0	0	0	0	0	0	0	0	0	0	0	0	0	0	0	0	0	0	0	0	0	0	0	0	0	1	
Low	Subject to Enforcement	PRC-004-WECC-1	Applicability Section	R	Point where aggregates to >75MVA	1	1	0	1	0	1	0	0	0	0	1	0	0	0	0	1	0	0	0	0	0	0	0	0	0	0	0	0	0	0	0	0	0	0	0	0	0	0	0	0	0	0	0	0	0	0	1	
Low	Subject to Future Enforcement	PRC-006-NPCC-1	By Requirement	R	Individual BES Resources/Elements	0	1	0	0	1	1	0	0	1	0	1	0	0	0	1	0	0	0	0	0	0	0	0	0	0	0	0	0	0	0	0	0	0	0	0	0	0	0	0	0	0	0	0	0	0	0	0	1
Low	Subject to Enforcement	PRC-006-SERC-01	By Requirement	R	Individual BES Resources/Elements	1	1	0	1	0	1	0	0	0	0	1	0	0	0	0	1	0	0	0	0	0	0	0	0	0	0	0	0	0	0	0	0	0	0	0	0	0	0	0	0	0	0	0	0	0	0	0	1
						13	3						5	1											3	0																					28						

Note: Verify/complete yellow cells.
Ensure rest aligns with the paper.
Delete rows not needed.

These values populate the summary table.

Unofficial Comment Form

Project 2014-01 Standards Applicability for Dispersed Generation Resources

Please **DO NOT** use this form for submitting comments. Please use the [electronic form](#) to submit comments on the posted documents. The electronic comment form must be completed by **January 20, 2015**.

If you have questions please contact [Katherine Street](#) (by email) or by telephone at 404-446-9702.

All documents for this project are available on the [project page](#).

Background Information

This posting solicits informal comments on the Project 2014-01 Standards Applicability for Dispersed Generation Resources (DGR) standards drafting team (SDT) revised draft White Paper, which provides background and technical rationale for proposed revisions to the applicability of several Reliability Standards. The revised draft White Paper is the second version following the first version posted on April 17, 2014. This version of the White Paper is intended to support the DGR SDT's recommendations on the high-priority DGR standards. The DGR SDT intends to post a third and final version of the White Paper at the conclusion of this project.

As explained in the White Paper, the goal of the DGR SDT is to ensure that Generator Owners (GOs) and Generator Operators (GOPs) of dispersed power producing resources are appropriately assigned responsibility for requirements that impact the reliability of the Bulk Power System (BPS), as the characteristics of operating dispersed power producing resources can be unique. In light of the revised BES definition approved by the Federal Energy Regulatory Authority (FERC) in 2014, the intent of this effort is generally to maintain the status quo for applicability of the standards as they have been applied over time with respect to dispersed power producing resources, where the status quo does not create a reliability gap, and to ensure continent-wide consistency in the application of Reliability Standards to dispersed power producing resources.

The DGR SDT performed a review of all standards that apply to GOs and GOPs (listed in Appendix A, as posted) and determined how each standard requirement should be appropriately applied to dispersed power producing resources, which are categorized as follows:

- The existing standard language is appropriate when applied to dispersed power producing resources and does not need to be addressed;

- The existing standard language is appropriate when applied to dispersed power producing resources but additional guidance is needed to clarify either how to implement the requirements for dispersed generating resources or how to demonstrate compliance for such resources; and
- The existing standard language needs to be modified in order to account for the unique characteristics of dispersed power producing resources. This could be accomplished through the Applicability Section of the standard in most cases; or, if required, through changes to the individual requirements. However, please note that any recommended changes to requirements are limited to changes in the applicability of the subject requirement and will not include technical changes to any requirement.

Other standards (listed in posted Appendix B) have been revised or require further review by the SDT to determine the necessity and the type of clarification or guidance to the applicability for dispersed power producing resources.

This posting includes three documents:

- Revised draft White Paper;
- Appendix A – List of all standards reviewed by the DGR SDT; and
- Appendix B – List of standards recommended as requiring further consideration for dispersed power producing resources.

You do not have to answer all questions. Enter comments in simple text format. Bullets, numbers, and special formatting will not be retained.

Questions

1. Do you agree with the accuracy of the technical content of the posted version of the White Paper? If not, please explain and offer alternative language.

- Yes
- No

Comments:

2. Do you have any additional comments to assist the DGR SDT in further developing its recommendations?

- Yes
- No

Comments:

Standards Announcement

Project 2014-01 Standards Applicability for Dispersed Generation Resources White Paper

Informal Comment Period Now Open through January 20, 2015

[Now Available](#)

An informal comment period for the Project 2014-01 Standards Applicability for Dispersed Generation Resources White Paper is now open through **8 p.m. Eastern on Tuesday, January 20, 2015.**

The white paper is intended to provide technical rationale and justification to support identification of standards that will require modifications to applicability for the unique characteristics of dispersed power producing resources as identified under Inclusion I4 of the BES definition that became effective on July 1, 2014. Background information for this project can be found on the [project page](#).

Instructions for Commenting

Please use the [electronic form](#) to submit comments. If you experience any difficulties in using the electronic form, please contact [Arielle Cunningham](#). An off-line, unofficial copy of the comment form is posted on the [project page](#).

Next Steps

The drafting team will review stakeholder comments and develop modifications for those standards for which modified applicability for dispersed generation resources is justified and supports reliability. In cases where applicability changes are developed for standards that are being modified in another standard development projects, the applicability changes will be coordinated with the drafting team making the technical changes, but will be balloted separately and filed for regulatory approval in a separate petition.

For information on the Standards Development Process, please refer to the [Standard Processes Manual](#).

*For more information or assistance, please contact [Katherine Street](#),
Standards Developer, or at 404-446-9702.*

North American Electric Reliability Corporation
3353 Peachtree Rd, NE
Suite 600, North Tower
Atlanta, GA 30326
404-446-2560 | www.nerc.com

Individual or group. (14 Responses)
Name (5 Responses)
Organization (5 Responses)
Group Name (9 Responses)
Lead Contact (9 Responses)
Question 1 (14 Responses)
Question 1 Comments (14 Responses)
Question 2 (13 Responses)
Question 2 Comments (14 Responses)

Group
Northeast Power Coordinating Council
Guy Zito
Yes
Yes
<p>Page numbers in the following comments refer to the clean version of the document. On the cover page the title should be revised to read Proposed Revisions to the Applicability of NERC Reliability Standards to Dispersed Generation Resources. In the second paragraph on page 5, it states "...This document provides justification of, and proposes revisions to, the applicability of the Reliability Standards and requirements, both existing and in development, and should be considered guidance for future standard development efforts..." This could result in considerable time savings and effort in the development of standards. Is there a mechanism in place for ensuring this is done? On page 9 above the table it is mentioned that "...In cases where a change is recommended to a regional standard, the SDT will notify the affected region." Is it appropriate for the SDT to make this notification, and when will the notification be made? Bulk Power System is used extensively on page 10, and not capitalized. If it is intended for its definition to be consistent with that listed in the NERC Glossary, it should be capitalized. Also, from the NERC Glossary, it should be Bulk-Power System. In Section 3.3.3 Prioritization Methodology, for high priority could exceptions be issued for entities to avoid the pitfalls of rushing changes to standards? Exceptions should be considered for medium and low priorities as well. In the medium priority bullet "appreciable reliability benefit" is used. What is considered an "appreciable reliability benefit"? There are operating conditions where the loss of 5MW can put the Bulk-Power System in an Emergency condition. On page 22 of 33 in Section 4.10.12 PRC-024— Generator Frequency and Voltage Protective Relay Settings, the second sentence should be reworded to read to be consistent with the language in the Rationale for Footnotes 4 and 6 in PRC-024-2: The SDT has determined it is appropriate to require that Protection System settings applied on both the individual generating units and aggregating equipment (including any Protection Systems applied on non-BES portions of the aggregating equipment), are set respecting the "no-trip zone" referenced in the requirements to maintain reliability of the BES. The Appendix A Source incorrectly lists PRC-002-1 as Pending Regulatory Approval. PRC-002-1 was remanded by FERC, and PRC-002-2 has been submitted to FERC and is Pending Regulatory Approval. This might appear elsewhere in the Appendices, and needs to be reviewed. PRC-002-1 dealt with installation requirements; PRC-002-2 deals with the capturing of data.</p>
Group
MRO-NERC Standards Review Forum
Joe Depoorter
No
<p>Page 7 of 33, last sentence states: "Thus, for some standards discussed in this paper it is appropriate to apply requirements at the plant level rather than the individual generating unit". If the SDT is inferring the "plant level" is the point of aggregation of 75 MVA or at the Facility (?), then please state that or provide a foot note. This term can be interpreted differently by each reader of this section. Section 4.4.4. The NSRF recommends that FAC-008-3 be restricted to only the individual generation resource per the I4 inclusion of the BES definition. FAC-001-1, R3 outlines Facility connection requirements. The TO can request updates of this information per R4. Note that</p>

GO/GOPs are either vertically integrated with their TOP or have a good working rapport with their TOP since working together since 2007. The industry does not need granular Requirements that fall outside the scope of the BES definition i.e., ratings of collector systems. If a TOP wants this information they can always request it outside of a NERC Standard.
Group
DTE Electric Co.
Kathleen Black
No
The discussion under PRC-004 (Section 4.10.4, paragraph 4) concerning setting errors on individual units suggests that this may be applicable even if less than 75 MVA is affected. The statement should be modified to clarify that only misoperations affecting more than 75 MVA are in scope.
No
No additional comments.
Individual
Thomas Foltz
American Electric Power
Yes
In the section for PRC-024, we believe the text "are set within the no-trip zone" is incorrect. Instead, the text should read as follows: "The SDT has determined it is appropriate to require that Protection System settings applied on both the individual generating units and aggregating equipment (including any Protection Systems applied on non-BES portions of the aggregating equipment are set *outside (or in accordance with)* the "no-trip zone" referenced in the requirements to maintain reliability of the BES."
No
Individual
Heather Bowden
EDP Renewables North America LLC
No
FAC-008: Technical guidance for FAC-008 is needed for dispersed power producing resources. For dispersed power producing resources, the Facility ratings should only be necessary for equipment which aggregates generation to 75 MVA or higher. The impact the individual generators have to the BES reliability is negligible. Since the NERC technical justification for applicability as presented in the Bulk Electric System Definition Reference Document dated April 2014 defines BES resources of being 75 MVA or higher, only the equipment that meets this threshold should be included. The applicability criteria for dispersed power producing resources should be consistent across the Reliability Standards.
Yes
Since the NERC technical justification for applicability as presented in the Bulk Electric System Definition Reference Document dated April 2014 defines BES resources of being 75 MVA or higher, only the equipment that meets this threshold should be included. The applicability criteria for dispersed power producing resources should be consistent across the Reliability Standards.
Group
Dominion
Connie Lowe
Yes
Yes
Dominion understands this whitepaper is constantly being updated and suggests the following be updated as the due dates below have past since the SDT redlined the document; Section 10.7 PRC-005-2; in the last sentence change January 22, 2014 to January 22, 2015 and update ballot

comments as this ballot has closed. Section 10.10 PRC-019-1; update results of PRC-10-1 comments/ballot that closed December 22, 2014. Section 10.12 PRC-024; needs to be updated with the PRC-024 posting initial comment/ballot that closed December 22, 2014. Section 4.11.2 TOP-001-3; footnote 25 - update results of TOP-001-3 ballot which closed on January 7, 2015.

Individual

Mike Smith

Manitoba Hydro

Yes

The terms BES and BPS are used inconsistently, making the white paper confusing to read.

No

Individual

Craig Jones

Idaho Power

Yes

No

Individual

RoLynda Shumpert

South Carolina Electric and Gas

Yes

No

Group

Southern Company: Southern Company Services, Inc.; Alabama Power Company; Georgia Power Company; Gulf Power Company; Mississippi Power Company; Southern Company Generation; Southern Company Generation and Energy Marketing

Pamela Hunter

No

The proposed changes included in FAC-008-3(X) are essentially specifying an unnecessary design review of entire PV and wind plants. This outcome of the proposed inclusion of generating resources identified in BES Definition Inclusion I4 in FAC-008 is not needed and is not necessary. The GO sharing of the ratings and capabilities of generating plant with planning entities is sufficiently and adequately in other existing NERC standards. To be specific, the generating plant MW and MVAR capabilities are required to be verified by MOD-025-2. The ability of a generating plant to remain connected for specified frequency and voltage excursions (and the reporting to the PC or TP any lack of the ability to do so) is required by PRC-024. The soon to be enforceable MOD-032 contains requirements for the GO to provide a plethora of plant specific modeling information (steady-state, dynamic, and short circuit) to the PC or TP including real power capabilities - gross maximum and minimum values; b. reactive power capabilities - maximum and minimum values at real power capabilities in a above; c. station service auxiliary load for normal plant configuration (provide data in the same manner as that required for aggregate Demand; d. regulated bus* and voltage set point* (as typically provided by the TOP); e. machine MVA base; f. generator step up transformer data (1. nominal voltages of windings, 2. impedance(s), 3. tap ratios (voltage or phase angle)*, 4. minimum and maximum tap position limits, 5. number of tap positions (for both the ULTC and NLTC), 6. regulated bus (for voltage regulating transformers)*, 7. ratings (normal and emergency)*, 8. in-service status*); g. generator type (hydro, wind, fossil, solar, nuclear, etc); h. in-service status* These realizations expose the fact that FAC-008-3 is not needed at all for generating resources. One sentence of the PRC-025 paragraph (page 28 of the 11 Dec 2014 draft) is incomplete: "The SDT has determined it is appropriate to require that Protection System settings applied on both the individual generating units at a dispersed generation power producing resource

site as applicable to this standard." The use of "both" makes it sound as though two independent parts will subsequently named, and they are not. TPL-007-1 contains a GO requirement and should be addressed by the white paper.
Yes
Since some standards (PRC-024) have recently been modified to account for the unique characteristics of dispersed power generating resources using footnotes, this method of modification should be mentioned in the third bullet of page 2 of the red line 11 Dec 2014 draft of the White Paper. This bullet could be revised to read: "The existing standard language needs to be modified in order to account for the unique characteristics of dispersed power producing resources. This could be accomplished through the applicability Applicability section Section of the standard in most cases, through narrowly- tailored changes to the individual requirements, if needed, or through the use of footnotes which clarify the applicability.
Group
Duke Energy
Colby Bellville
Yes
No
Duke Energy would like to thank the drafting team for its efforts in drafting the DGR White Paper.
Group
ACES Standards Collaborators
Jason Marshall
No
(1) The drafting team has done an excellent job reviewing all of the standards that apply to GOs and GOPs and also identifying some of the ancillary issues such as the interaction of BAs, TOPs, and RCs and dispersed generation resources. However, we do believe there are still some issues that have not been fully addressed in the white paper. (2) The white paper should explain why the drafting team modified its view on both MOD-026 and MOD-027. It only says upon further review the drafting team no longer believes the applicability requires further refinement. What specifically in the review changed the drafting team's mind? This should be explained in the white paper. (3) We disagree that PRC-001-1.1 R2 does not require modifications. While we agree with the SDT's interpretation that the loss of an individual generating unit at a dispersed generation resource will not have material impact on reliability and therefore the requirement is not applicable, we do not believe all GOPs (and possibly auditors) will interpret the requirement in this manner. GOPs may not have the transmission system knowledge to understand that losing a single generation resource in a dispersed generation site does not have a material impact on reliability. A simple revision or technical explanation in the application guidelines section is warranted to be sure everyone interprets the standard consistent with the drafting team's explanation in the white paper. (4) The TOP standards section of the white paper needs a wholesale re-evaluation as it appears to be out of sync with the work of the Project 2014-03 TOP and IRO Revisions standards drafting team. This drafting team is wrapping up their work and all standards have either passed the initial/additional ballot or have passed the final ballot and appear to be different than what was evaluated. For instance, TOP-001-3 is much broader than described in the white paper and encompasses much more than ensuring "TOP directives are complied with." Further, TOP-002-4 and TOP-003-3 were not even evaluated in the white paper. Since the SDT has not identified the existing TOP standards as high priority issues, will the SDT truly recommend changes to them when they will be replaced by the standards from Project 2014-03? (5) The CIP section is confusing and requires additional modification. Based on the inclusion of the low impact requirements or "Elements" as described in the white paper and from Attachment 1 in CIP-003-7, it would appear that there is an assumption that these dispersed generation resources could never be categorized as medium or high impact. We are not sure this will be universally true. However, if the drafting team is making this assumption, please document it explicitly in the white paper. Furthermore, we recommend removing the low impact requirements/"Elements" from the white paper as they are not final and do not provide any additional clarification to the work of this drafting team at this juncture.
No

Thank you for the opportunity to comment.
Group
Arizona Public Service Company
Kristie Cocco
No
FAC-008: SDT recommends additional guidance but intent is not clear. Any of the facility components in a dispersed generation complex should not be subjected to facility rating calculations. There is very little reliability benefit in doing so. The dispersed power generation complex is not subjected to higher loadings than the design value for any realistic scenario.
Yes
TOP-001-3 Requirements R13, R14, R15 should not apply to variable generation even at the aggregate level. It is hard to predict reduction in real and reactive power capability of variable generation units in real time. There is no reliability benefits of these standards as applied to variable generation. TOP needs to be prepared for maximum changes in real and reactive power from these complexes.
Group
SPP Standards Review Group
Robert Rhodes
No
Reference is made to BES reliability in 4.7.3 MOD-024-1, 4.7.4 MOD-025-1 and 4.7.5 MOD-025-2 whereas the reference is to 'reliability of the BPS' in 4.6.3 IRO-010. It appears that the drafting team swaps back and forth from one to the other quite often in the document. We should be consistent throughout the whitepaper. We prefer BES reliability. Section 4.11 TOP may need to be revised based on the on-going Project 2014-03 Revisions to TOP and IRO Standards which has extensively revised the TOP standards. TOP-002-4 and TOP-003-3 have been accepted by the industry and adopted by the NERC Board. TOP-001-3 is currently posted for Final Ballot having successfully passed its last additional ballot which closed on January 7, 2015. The 1st sentence in the 1st bullet under 4.11.3.2 Requirement R13 is not very clear. Without knowing exactly what the SDT is trying to say, we offer the following as a possible replacement. 'Due to the number of individual generators at a dispersed power producing resource, the internal Real Power losses, and the natural inductance and capacitance of dispersed power resource systems connected in series, verification of real and reactive capabilities should be conducted at the dispersed power producing resource aggregate Facility level.'
Yes
The following are primarily typo/grammatical suggestions. In the first line of the Executive Summary the SDT uses White Paper when referring to the document. The Project 2014-03 SDT most recently used whitepaper when referencing its System Operating Limit (SOL) document. NERC needs to be consistent with the use of whitepaper in all documentation across all projects. Also in the first paragraph of the Executive Summary, hyphenate Bulk-Power System as defined in the NERC Glossary of Terms Used in Reliability Standards. Change the 'and' at the end of the 2nd bullet in the 2nd paragraph of the Executive Summary to 'or'. Delete 'be' in the next to last line of the 1st paragraph on Page 2 of the Executive Summary. Delete the comma after 'Standards Committee' in the 1st line of the 1st paragraph under 3 Background. Capitalize 'Transmission' in the 1st line of the 3rd paragraph under 3.2.1 Design Characteristics. Be sure it is capitalized correctly throughout the whitepaper. For example, in the last line of the 2nd paragraph under 3.2.2 Operational Characteristics. Insert 'the' between 'affect' and 'GO' in the 3rd line of the paragraph under 4.1 BAL. Delete the phrase 'changes to add' in the next to last line of the 2nd paragraph under 4.4.4 FAC-008 – Facility Ratings. Change the references to MOD-032 in 4.7.1 MOD-010 and 4.7.2 MOD-012 from 5.7.8 to 4.7.8. Replace 'do' with 'does' in the last line of the paragraph under 4.9 PER. Capitalize 'Protection Systems' in the next to last line of the last paragraph under 4.10.1 PRC-001-1.1 – System Protection Coordination. Replace 'is' with 'was' in the first line of the paragraph under 4.10.2 PRC-001-2 – System Protection Coordination. In the 3rd line of the same paragraph, change 'This Standard version...' to 'This standard version...'. Replace 'do' with 'does' in the last line of the paragraph under 4.10.3 PRC-002-NPCC-01 – Disturbance Monitoring. As in the previously mentioned comment on 4.9 PER, standards is not the subject of these sentences, applicability is. 'Does' is the

proper verb to attain subject/verb agreement. Change the reference to 'BPS criteria' in the 2nd line of the 1st paragraph under 4.10.4 PRC-004-2.1a – Analysis and Mitigation of Transmission and Generation Protection System Misoperations to 'BES criteria' since the Purpose of PRC-004-2.1a refers to '...reliability of the Bulk Electric System (BES)...'. Additional consideration should be given to the references to BPS reliability in this paragraph. (See our comment in Question 1 above.) Make the plural 'operations' in the 2nd line of the 4th paragraph under 4.10.4 PRC-004-2.1a – Analysis and Mitigation of Transmission and Generation Protection System Misoperations parenthetical 'operation(s)' since it could be singular or plural. Capitalize 'Misoperation' in the 3rd line of the 5th paragraph under 4.10.4 PRC-004-2.1a – Analysis and Mitigation of Transmission and Generation Protection System Misoperations. Replace 'benefit' with 'benefits' in the 2nd line of the 1st paragraph under 4.10.7 PRC-005-2 – Protection System Maintenance. Capitalize 'Transmission' in the 2nd line of the 3rd paragraph under 4.10.7 PRC-005-2 – Protection System Maintenance. There has apparently been some sort of mix-up between the redline version and the clean version of the whitepaper regarding the last paragraph under 4.10.7 PRC-005-2 – Protection System Maintenance and the beginning of 4.10.8 PRC-006-NPCC-1 – Automatic Underfrequency Load Shedding. Capitalize 'Transmission Lines' in the 3rd and 7th lines of the paragraph under 4.10.11 PRC-023 – Transmission Relay Loadability. Capitalize 'Protection Systems' in the 10th line of the paragraph under 4.10.12 PRC-024 – Generator Frequency and Voltage Protective Relay Settings. Capitalize 'Protection Systems' in the 10th line of the paragraph under 4.10.13 PRC-025 – Generator Relay Loadability. Revise the 3rd line of the paragraph under 4.11 TOP to read 'directives to the GOP, and that the GOP will follow such directives. They also ensure GOPs render all available'. Capitalize 'Real-time' in the 6th line of the 1st paragraph and the 1st line of the 2nd bullet under 4.11.1.3 Requirement R7. Also replace 'generator' with 'generation' in the 9th line of the 1st paragraph and the last line of the 2nd paragraph of the same section. Delete the 'in' in the 6th line of the paragraph under 4.11.3.1 Requirement R3. Replace the '<' with 'less than' in the 1st line of the 2nd bullet under 4.11.3.2 Requirement R13. Capitalize 'Real-time' in the 4th sentence of the 1st paragraph and the 1st line of the 2nd bullet under 4.11.3.3 Requirement R14. Replace the 6th line and part of the 7th line of the 1st paragraph with the following: 'resources. The SDT recommends that the GOP notify the TOP of any unplanned changes in real output capabilities above 20 MVA at the aggregate Facility level.' Replace 'resources' in the 1st line of the 2nd paragraph with 'resource'. Replace 'has' with 'have' in the 2nd line of the 2nd paragraph under 4.11.3.4 Requirement R15. Replace the '>' in the 2nd line of the paragraph under 4.11.4.1 Requirement R1 with 'greater than'. Replace 'has' with 'have' in the 2nd line of the 2nd paragraph under 4.11.4.2 Requirement R2. Capitalize 'Real-time' in the 3rd and 5th lines of the 1st paragraph under 4.11.5 TOP-006 – Monitoring System Conditions. In the same section, also capitalize 'Real-time' in the 1st and 3rd lines of the 3rd bullet. Lastly, capitalize 'Real-time' in the 4th line of the 2nd paragraph of the same section. Replace the '<' in the 2nd line of the 1st bullet of the same section with 'less than'. Also in the 7th line of the 2nd paragraph, replace 'less' with 'other'. In the next line, delete the 'in'. Replace 'resource' with 'resources' in the 5th line of the paragraph under 4.13.1 VAR-001 – Voltage and Reactive Control (WECC Regional Variance). Do not change 'occurs' to 'occur'. Replace 'resource' with 'resources' in the 5th line of the 1st paragraph under 4.13.2 VAR-002-2b – Generator Operation for Maintaining Network Voltage Schedules. Again, do not change 'occurs' to 'occur'. Capitalize 'Transmission' in the last line of the 2nd paragraph. The paragraph under 4.13.3 shows up as part of the title of 4.13.4 in the clean version. Insert 'of' between '30 minutes,' and 'any' in the 1st line of what should be the paragraph under 4.13.3 VAR-002-2b – Requirement R3.1. Replace 'changes' with 'change' in the 2nd line of the same paragraph. Replace 'is' with 'are' in the 4th line of the same paragraph. We suggest rewording the 3rd paragraph under 4.14.1 CIP v5 to read: 'During Project 2014-02 CIP Version 5 Revisions' first comment period, the SDT received comments to modify the Applicability Section of CIP-003-6. The CIP SDT made drastic modifications in the second posting of CIP-003-6, which was posted for an additional 45-day comment and ballot period on September 3, 2014, to take into account all of the comments received during the first posting.' 'Responsible entity' is capitalized extensively in 4.14.1 CIP v5 but it is not a defined term in the Glossary of Terms. Delete 'The' in the 4th line of the 4th paragraph under 4.14.1 CIP v5. Also, delete the 'the' in front of 'Attachment 1' in the last line of the same paragraph.

Standard Development Timeline

This section is maintained by the drafting team during the development of the standard and will be removed when the standard becomes effective.

Development Steps Completed

1. SAR posted for comment November 20, 2013 – December 19, 2013.
2. An earlier draft of this standard was posted for a 45-day comment and ballot period June 12, 2014–July 29, 2014.
3. PRC-005-3(X) passed a final ballot, which was posted for a 10-day ballot period of August 27, 2014-September 5, 2014.
4. PRC-005-5 passed an initial ballot, which was posted for a 45-day Formal Comment Period with Parallel Ballot December 8, 2014 – January 22, 2015.

Description of Current Draft

The Dispersed Generation Resources Standard Drafting Team (DGR SDT) is posting this version of PRC-005 for final ballot under the new Standards Process Manual (Effective: June 26, 2013). This version includes all substantive changes recently approved by the NERC Board of Trustees in addition to applicability changes recommended by the DGR SDT.

Anticipated Actions	Anticipated Dates
45-day Formal Comment Period with Parallel Ballot	December 8, 2014 – January 22, 2015
Final ballot	March 2015
BOT adoption	May 2015

Definitions of Terms Used in Standard

This section includes all newly defined or revised terms used in the proposed standard. Terms already defined in the Reliability Standards Glossary of Terms (Glossary) are not repeated here. New or revised definitions listed below become approved when the proposed standard is approved. When the standard becomes effective, this defined term will be removed from the individual standard and added to the Glossary.

None.

A. Introduction

1. **Title:** Protection System, Automatic Reclosing, and Sudden Pressure Relaying Maintenance
2. **Number:** PRC-005-5
3. **Purpose:** To document and implement programs for the maintenance of all Protection Systems, Automatic Reclosing, and Sudden Pressure Relaying affecting the reliability of the Bulk Electric System (BES) so that they are kept in working order.
4. **Applicability:**
 - 4.1. **Functional Entities:**
 - 4.1.1 Transmission Owner
 - 4.1.2 Generator Owner
 - 4.1.3 Distribution Provider
 - 4.2. **Facilities:**
 - 4.2.1 Protection Systems and Sudden Pressure Relaying that are installed for the purpose of detecting Faults on BES Elements (lines, buses, transformers, etc.)
 - 4.2.2 Protection Systems used for underfrequency load-shedding systems installed per ERO underfrequency load-shedding requirements.
 - 4.2.3 Protection Systems used for undervoltage load-shedding systems installed to prevent system voltage collapse or voltage instability for BES reliability.
 - 4.2.4 Protection Systems installed as a Remedial Action Scheme (RAS) for BES reliability.
 - 4.2.5 Protection Systems and Sudden Pressure Relaying for generator Facilities that are part of the BES, except for generators identified through Inclusion I4 of the BES definition, including:
 - 4.2.5.1 Protection Systems that act to trip the generator either directly or via lockout or auxiliary tripping relays.
 - 4.2.5.2 Protection Systems and Sudden Pressure Relaying for generator step-up transformers for generators that are part of the BES.

Rationale for section 4.2.5: These applicability revisions are intended to clarify and provide for consistent application of the Requirements to BES generator Facilities included in the BES through Inclusion I4 – Dispersed Power Producing Resources. The SDT modified the language for clarity based on comments received and is not changing the intent of the standard modification from the last posted version of this standard.

4.2.5.3 Protection Systems and Sudden Pressure Relaying for station service or excitation transformers connected to the generator bus of generators which are part of the BES, that act to trip the generator either directly or via lockout or tripping auxiliary relays.

4.2.6 Protection Systems and Sudden Pressure Relaying for the following BES generator Facilities for dispersed power producing resources identified through Inclusion I4 of the BES definition:

4.2.6.1 Protection Systems and Sudden Pressure Relaying for Facilities used in aggregating dispersed BES generation from the point where those resources aggregate to greater than 75 MVA to a common point of connection at 100kV or above.

4.2.7 Automatic Reclosing¹, including:

4.2.7.1 Automatic Reclosing applied on the terminals of Elements connected to the BES bus located at generating plant substations where the total installed gross generating plant capacity is greater than the gross capacity of the largest BES generating unit within the Balancing Authority Area or, if a member of a Reserve Sharing Group, the largest generating unit within the Reserve Sharing Group.²

4.2.7.2 Automatic Reclosing applied on the terminals of all BES Elements at substations one bus away from generating plants specified in Section 4.2.7.1 when the substation is less than 10 circuit-miles from the generating plant substation.

4.2.7.3 Automatic Reclosing applied as an integral part of an RAS specified in Section 4.2.4.

5. Effective Date: See the Implementation Plan for this standard.

6. Definitions Used in this Standard:

Automatic Reclosing – Includes the following Components:

- Reclosing relay
- Control circuitry associated with the reclosing relay.

¹ Automatic Reclosing addressed in Section 4.2.7.1 and 4.2.7.2 may be excluded if the equipment owner can demonstrate that a close-in three-phase fault present for twice the normal clearing time (capturing a minimum trip-close-trip time delay) does not result in a total loss of gross generation in the Interconnection exceeding the gross capacity of the largest relevant BES generating unit where the Automatic Reclosing is applied.

² The largest BES generating unit within the Balancing Authority Area or the largest generating unit within the Reserve Sharing Group, as applicable, is subject to change. As a result of such a change, the Automatic Reclosing Components subject to the standard could change effective on the date of such change.

Sudden Pressure Relaying – A system that trips an interrupting device(s) to isolate the equipment it is monitoring and includes the following Components:

- Fault pressure relay – a mechanical relay or device that detects rapid changes in gas pressure, oil pressure, or oil flow that are indicative of Faults within liquid-filled, wire-wound equipment
- Control circuitry associated with a fault pressure relay

Unresolved Maintenance Issue – A deficiency identified during a maintenance activity that causes the Component to not meet the intended performance, cannot be corrected during the maintenance interval, and requires follow-up corrective action.

Segment – Components of a consistent design standard, or a particular model or type from a single manufacturer that typically share other common elements. Consistent performance is expected across the entire population of a Segment. A Segment must contain at least sixty (60) individual Components.

Component Type –

- Any one of the five specific elements of a Protection System.
- Any one of the two specific elements of Automatic Reclosing.
- Any one of the two specific elements of Sudden Pressure Relaying.

Component – Any individual discrete piece of equipment included in a Protection System, Automatic Reclosing, or Sudden Pressure Relaying.

Countable Event – A failure of a Component requiring repair or replacement, any condition discovered during the maintenance activities in Tables 1-1 through 1-5, Table 3, Tables 4-1 through 4-2, and Table 5, which requires corrective action or a Protection System Misoperation attributed to hardware failure or calibration failure. Misoperations due to product design errors, software errors, relay settings different from specified settings, Protection System Component, Automatic Reclosing, or Sudden Pressure Relaying configuration or application errors are not included in Countable Events.

B. Requirements and Measures

- R1.** Each Transmission Owner, Generator Owner, and Distribution Provider shall establish a Protection System Maintenance Program (PSMP) for its Protection Systems, Automatic Reclosing, and Sudden Pressure Relaying identified in Section 4.2, Facilities. *[Violation Risk Factor: Medium] [Time Horizon: Operations Planning]*

The PSMP shall:

- 1.1.** Identify which maintenance method (time-based, performance-based per PRC-005 Attachment A, or a combination) is used to address each Protection System,

Automatic Reclosing, and Sudden Pressure Relaying Component Type. All batteries associated with the station dc supply Component Type of a Protection System shall be included in a time-based program as described in Table 1-4 and Table 3.

- 1.2.** Include the applicable monitored Component attributes applied to each Protection System, Automatic Reclosing, and Sudden Pressure Relaying Component Type consistent with the maintenance intervals specified in Tables 1-1 through 1-5, Table 2, Table 3, Table 4-1 through 4-2, and Table 5 where monitoring is used to extend the maintenance intervals beyond those specified for unmonitored Protection System, Automatic Reclosing, and Sudden Pressure Relaying Components.
- M1.** Each Transmission Owner, Generator Owner and Distribution Provider shall have a documented Protection System Maintenance Program in accordance with Requirement R1.

For each Protection System, Automatic Reclosing, and Sudden Pressure Relaying Component Type, the documentation shall include the type of maintenance method applied (time-based, performance-based, or a combination of these maintenance methods), and shall include all batteries associated with the station dc supply Component Types in a time-based program as described in Table 1-4 and Table 3. (Part 1.1)

For Component Types that use monitoring to extend the maintenance intervals, the responsible entity(s) shall have evidence for each Protection System, Automatic Reclosing, and Sudden Pressure Relaying Component Type (such as manufacturer's specifications or engineering drawings) of the appropriate monitored Component attributes as specified in Tables 1-1 through 1-5, Table 2, Table 3, Table 4-1 through 4-2, and Table 5. (Part 1.2)
- R2.** Each Transmission Owner, Generator Owner, and Distribution Provider that uses performance-based maintenance intervals in its PSMP shall follow the procedure established in PRC-005 Attachment A to establish and maintain its performance-based intervals. [*Violation Risk Factor: Medium*] [*Time Horizon: Operations Planning*]
- M2.** Each Transmission Owner, Generator Owner, and Distribution Provider that uses performance-based maintenance intervals shall have evidence that its current performance-based maintenance program(s) is in accordance with Requirement R2, which may include, but is not limited to, Component lists, dated maintenance records, and dated analysis records and results.
- R3.** Each Transmission Owner, Generator Owner, and Distribution Provider that utilizes time-based maintenance program(s) shall maintain its Protection System, Automatic Reclosing, and Sudden Pressure Relaying Components that are included within the time-based maintenance program in accordance with the minimum maintenance activities and maximum maintenance intervals prescribed within Tables 1-1 through

1-5, Table 2, Table 3, Table 4-1 through 4-2, and Table 5. *[Violation Risk Factor: High]*
[Time Horizon: Operations Planning]

- M3.** Each Transmission Owner, Generator Owner, and Distribution Provider that utilizes time-based maintenance program(s) shall have evidence that it has maintained its Protection System, Automatic Reclosing, and Sudden Pressure Relaying Components included within its time-based program in accordance with Requirement R3. The evidence may include, but is not limited to, dated maintenance records, dated maintenance summaries, dated check-off lists, dated inspection records, or dated work orders.
- R4.** Each Transmission Owner, Generator Owner, and Distribution Provider that utilizes performance-based maintenance program(s) in accordance with Requirement R2 shall implement and follow its PSMP for its Protection System, Automatic Reclosing, and Sudden Pressure Relaying Components that are included within the performance-based program(s). *[Violation Risk Factor: High]* *[Time Horizon: Operations Planning]*
- M4.** Each Transmission Owner, Generator Owner, and Distribution Provider that utilizes performance-based maintenance intervals in accordance with Requirement R2 shall have evidence that it has implemented the Protection System Maintenance Program for the Protection System, Automatic Reclosing, and Sudden Pressure Relaying Components included in its performance-based program in accordance with Requirement R4. The evidence may include, but is not limited to, dated maintenance records, dated maintenance summaries, dated check-off lists, dated inspection records, or dated work orders.
- R5.** Each Transmission Owner, Generator Owner, and Distribution Provider shall demonstrate efforts to correct identified Unresolved Maintenance Issues. *[Violation Risk Factor: Medium]* *[Time Horizon: Operations Planning]*
- M5.** Each Transmission Owner, Generator Owner, and Distribution Provider shall have evidence that it has undertaken efforts to correct identified Unresolved Maintenance Issues in accordance with Requirement R5. The evidence may include, but is not limited to, work orders, replacement Component orders, invoices, project schedules with completed milestones, return material authorizations (RMAs) or purchase orders.

C. Compliance

1. Compliance Monitoring Process

1.1. Compliance Enforcement Authority

As defined in the NERC Rules of Procedure, “Compliance Enforcement Authority” means NERC or the Regional Entity in their respective roles of monitoring and enforcing compliance with the NERC Reliability Standards.

1.2. Evidence Retention

The following evidence retention periods identify the period of time an entity is required to retain specific evidence to demonstrate compliance. For instances where the evidence retention period specified below is shorter than the time since the last audit, the Compliance Enforcement Authority may ask an entity to provide other evidence to show that it was compliant for the full time period since the last audit.

The Transmission Owner, Generator Owner, and Distribution Provider shall each keep data or evidence to show compliance as identified below unless directed by its Compliance Enforcement Authority to retain specific evidence for a longer period of time as part of an investigation.

For Requirement R1, the Transmission Owner, Generator Owner, and Distribution Provider shall each keep its current dated Protection System Maintenance Program, as well as any superseded versions since the preceding compliance audit, including the documentation that specifies the type of maintenance program applied for each Protection System, Automatic Reclosing, or Sudden Pressure Relaying Component Type.

For Requirement R2, Requirement R3, and Requirement R4, in cases where the interval of the maintenance activity is longer than the audit cycle, the Transmission Owner, Generator Owner, and Distribution Provider shall each keep documentation of the most recent performance of that maintenance activity for the Protection System, Automatic Reclosing, or Sudden Pressure Relaying Component. In cases where the interval of the maintenance activity is shorter than the audit cycle, documentation of all performances (in accordance with the tables) of that maintenance activity for the Protection System, Automatic Reclosing, or Sudden Pressure Relaying Component since the previous scheduled audit date shall be retained.

For Requirement R5 the Transmission Owner, Generator Owner, and Distribution Provider shall each keep documentation of Unresolved Maintenance Issues identified by the entity since the last audit, including all that were resolved since the last audit.

The Compliance Enforcement Authority shall keep the last audit records and all requested and submitted subsequent audit records.

1.3. Compliance Monitoring and Assessment Processes:

Compliance Audits

Self-Certifications

Spot Checking

Compliance Violation Investigations

Self-Reporting

Complaints

1.4. Additional Compliance Information

None

Table of Compliance Elements

Requirement Number	Lower VSL	Moderate VSL	High VSL	Severe VSL
R1	The entity’s PSMP failed to specify whether one Component Type is being addressed by time-based or performance-based maintenance, or a combination of both (Part 1.1).	The entity’s PSMP failed to specify whether two Component Types are being addressed by time-based or performance-based maintenance, or a combination of both (Part 1.1).	<p>The entity’s PSMP failed to specify whether three Component Types are being addressed by time-based or performance-based maintenance, or a combination of both. (Part 1.1).</p> <p>OR</p> <p>The entity’s PSMP failed to include the applicable monitoring attributes applied to each Component Type consistent with the maintenance intervals specified in Tables 1-1 through 1-5, Table 2, Table 3, Tables 4-1 through 4-2, and Table 5 where monitoring is used to extend the maintenance intervals beyond those specified for unmonitored Components (Part 1.2).</p>	<p>The entity failed to establish a PSMP.</p> <p>OR</p> <p>The entity’s PSMP failed to specify whether four or more Component Types are being addressed by time-based or performance-based maintenance, or a combination of both (Part 1.1).</p> <p>OR</p> <p>The entity’s PSMP failed to include applicable station batteries in a time-based program (Part 1.1).</p>
R2	The entity uses performance-based maintenance intervals in its PSMP but failed to reduce Countable Events to no more than 4% within three years.	NA	The entity uses performance-based maintenance intervals in its PSMP but failed to reduce Countable Events to no more than 4% within four years.	<p>The entity uses performance-based maintenance intervals in its PSMP but:</p> <ol style="list-style-type: none"> 1) Failed to establish the technical justification described within Requirement R2 for the initial use of the performance-based PSMP <p>OR</p> <ol style="list-style-type: none"> 2) Failed to reduce Countable Events to no more than 4% within five years <p>OR</p>

Requirement Number	Lower VSL	Moderate VSL	High VSL	Severe VSL
				3) Maintained a Segment with less than 60 Components OR 4) Failed to: <ul style="list-style-type: none"> • Annually update the list of Components, OR • Annually perform maintenance on the greater of 5% of the Segment population or 3 Components, OR • Annually analyze the program activities and results for each Segment.
R3	For Components included within a time-based maintenance program, the entity failed to maintain 5% or less of the total Components included within a specific Component Type in accordance with the minimum maintenance activities and maximum maintenance intervals prescribed within Tables 1-1 through 1-5, Table 2, Table 3, Tables 4-1 through 4-2, and Table 5.	For Components included within a time-based maintenance program, the entity failed to maintain more than 5% but 10% or less of the total Components included within a specific Component Type in accordance with the minimum maintenance activities and maximum maintenance intervals prescribed within Tables 1-1 through 1-5, Table 2, Table 3, Tables 4-1 through 4-2, and Table 5.	For Components included within a time-based maintenance program, the entity failed to maintain more than 10% but 15% or less of the total Components included within a specific Component Type in accordance with the minimum maintenance activities and maximum maintenance intervals prescribed within Tables 1-1 through 1-5, Table 2, Table 3, Tables 4-1 through 4-2, and Table 5.	For Components included within a time-based maintenance program, the entity failed to maintain more than 15% of the total Components included within a specific Component Type in accordance with the minimum maintenance activities and maximum maintenance intervals prescribed within Tables 1-1 through 1-5, Table 2, Table 3, Tables 4-1 through 4-2, and Table 5.

Requirement Number	Lower VSL	Moderate VSL	High VSL	Severe VSL
R4	For Components included within a performance-based maintenance program, the entity failed to maintain 5% or less of the annual scheduled maintenance for a specific Component Type in accordance with their performance-based PSMP.	For Components included within a performance-based maintenance program, the entity failed to maintain more than 5% but 10% or less of the annual scheduled maintenance for a specific Component Type in accordance with their performance-based PSMP.	For Components included within a performance-based maintenance program, the entity failed to maintain more than 10% but 15% or less of the annual scheduled maintenance for a specific Component Type in accordance with their performance-based PSMP.	For Components included within a performance-based maintenance program, the entity failed to maintain more than 15% of the annual scheduled maintenance for a specific Component Type in accordance with their performance-based PSMP.
R5	The entity failed to undertake efforts to correct 5 or fewer identified Unresolved Maintenance Issues.	The entity failed to undertake efforts to correct greater than 5 but less than or equal to 10 identified Unresolved Maintenance Issues.	The entity failed to undertake efforts to correct greater than 10 but less than or equal to 15 identified Unresolved Maintenance Issues.	The entity failed to undertake efforts to correct greater than 15 identified Unresolved Maintenance Issues.

D. Regional Variances

None.

E. Interpretations

None.

Supplemental Reference Documents

The following documents present a detailed discussion about determination of maintenance intervals and other useful information regarding establishment of a maintenance program.

1. *Supplementary Reference and FAQ - PRC-005-4 Protection System Maintenance*, Protection System Maintenance and Testing Standard Drafting Team (April 2014)
2. *Considerations for Maintenance and Testing of Auto-reclosing Schemes*, NERC System Analysis and Modeling Subcommittee, and NERC System Protection and Control Subcommittee (November 2012)
3. *Sudden Pressure Relays and Other Devices that Respond to Non-Electrical Quantities – SPCS Input for Standard Development in Response to FERC Order No. 758*, NERC System Protection and Control Subcommittee (December 2013)
4. *Sudden Pressure Relays and Other Devices that Respond to Non-Electrical Quantities – Supplemental Information to Support Project 2007-17.3: Protection System Maintenance and Testing* (October 31, 2014)

Version History

Version	Date	Action	Change Tracking
0	February 8, 2005	Adopted by NERC Board of Trustees	New
1	February 7, 2006	Adopted by NERC Board of Trustees	<ol style="list-style-type: none"> 1. Changed incorrect use of certain hyphens (-) to “en dash” (–) and “em dash (—).” 2. Added “periods” to items where appropriate. Changed “Timeframe” to “Time Frame” in item D, 1.2.
1a	February 17, 2011	Adopted by NERC Board of Trustees	Added Appendix 1 - Interpretation regarding applicability of standard to protection of radially connected transformers developed in Project 2009-17

Version	Date	Action	Change Tracking
1b	November 5, 2009	Adopted by NERC Board of Trustees	Interpretation of R1, R1.1, and R1.2 developed by Project 2009-10
1b	February 3, 2012	FERC Order approving revised definition of “Protection System”	Per footnote 8 of FERC’s order, the definition of “Protection System” supersedes interpretation “b” of PRC-005-1b upon the effective date of the modified definition (i.e., April 1, 2013) <i>See N. Amer. Elec. Reliability Corp., 138 FERC ¶ 61,095 (February 3, 2012).</i>
1.1b	May 9, 2012	Adopted by NERC Board of Trustees	Errata change developed by Project 2010-07, clarified inclusion of generator interconnection Facility in Generator Owner’s responsibility
2	November 7, 2012	Adopted by NERC Board of Trustees	Project 2007-17 - Complete revision, absorbing maintenance requirements from PRC-005-1.1b, PRC-008-0, PRC-011-0, PRC-017-0
2	October 17, 2013	Approved by NERC Standards Committee	Errata Change: The Standards Committee approved an errata change to the implementation plan for PRC-005-2 to add the phrase “or as otherwise made effective pursuant to the laws applicable to such ERO governmental authorities;” to the second sentence under the “Retirement of Existing Standards” section. (no change to standard version number)
2	March 7, 2014	Adopted by NERC Board of Trustees	Modified R1 VSL in response to FERC directive (no change to standard version number)
2(i)	November 13, 2014	Adopted by NERC Board of Trustees	Applicability section revised by Project 2014-01 to clarify application of Requirements to BES dispersed power producing resources

Version	Date	Action	Change Tracking
2(ii)	November 13, 2014	Adopted by NERC Board of Trustees	Replaced references to Special Protection System and SPS with Remedial Action Scheme and RAS
3	November 7, 2013	Adopted by the NERC Board of Trustees	Revised to address the FERC directive in Order No. 758 to include Automatic Reclosing in maintenance programs
3	February 12, 2014	Approved by NERC Standards Committee	Errata Change: The Standards Committee approved errata changes to correct capitalization of certain defined terms within the definitions of “Unresolved Maintenance Issue” and “Protection System Maintenance Program”. The changes will be reflected in the definitions section of PRC-005-3 for “Unresolved Maintenance Issue” and in the NERC Glossary of Terms for “Protection System Maintenance Program”. (no change to standard version number)
3	March 7, 2014	Adopted by NERC Board of Trustees	Modified R1 VSL in response to FERC directive (no change to standard version number)
3(i)	November 13, 2014	Adopted by NERC Board of Trustees	Applicability section revised by Project 2014-01 to clarify application of Requirements to BES dispersed power producing resources
3(ii)	November 13, 2014	Adopted by NERC Board of Trustees	Replaced references to Special Protection System and SPS with Remedial Action Scheme and RAS
4	November 13, 2014	Adopted by NERC Board of Trustees	Added Sudden Pressure Relaying in response to FERC Order No. 758

Version	Date	Action	Change Tracking
5	TBD		Applicability section revised by Project 2014-01 to clarify application of Requirements to BES dispersed power producing resources

Table 1-1 Component Type - Protective Relay Excluding distributed UFLS and distributed UVLS (see Table 3)		
Component Attributes	Maximum Maintenance Interval ³	Maintenance Activities
Any unmonitored protective relay not having all the monitoring attributes of a category below.	6 Calendar Years	For all unmonitored relays: <ul style="list-style-type: none"> • Verify that settings are as specified For non-microprocessor relays: <ul style="list-style-type: none"> • Test and, if necessary calibrate For microprocessor relays: <ul style="list-style-type: none"> • Verify operation of the relay inputs and outputs that are essential to proper functioning of the Protection System. • Verify acceptable measurement of power system input values.
Monitored microprocessor protective relay with the following: <ul style="list-style-type: none"> • Internal self-diagnosis and alarming (see Table 2). • Voltage and/or current waveform sampling three or more times per power cycle, and conversion of samples to numeric values for measurement calculations by microprocessor electronics. • Alarming for power supply failure (see Table 2). 	12 Calendar Years	Verify: <ul style="list-style-type: none"> • Settings are as specified. • Operation of the relay inputs and outputs that are essential to proper functioning of the Protection System. • Acceptable measurement of power system input values.

³ For the tables in this standard, a calendar year starts on the first day of a new year (January 1) after a maintenance activity has been completed. For the tables in this standard, a calendar month starts on the first day of the first month after a maintenance activity has been completed.

Table 1-1 Component Type - Protective Relay Excluding distributed UFLS and distributed UVLS (see Table 3)		
Component Attributes	Maximum Maintenance Interval ³	Maintenance Activities
Monitored microprocessor protective relay with preceding row attributes and the following: <ul style="list-style-type: none"> • Ac measurements are continuously verified by comparison to an independent ac measurement source, with alarming for excessive error (See Table 2). • Some or all binary or status inputs and control outputs are monitored by a process that continuously demonstrates ability to perform as designed, with alarming for failure (See Table 2). • Alarming for change of settings (See Table 2). 	12 Calendar Years	Verify only the unmonitored relay inputs and outputs that are essential to proper functioning of the Protection System.

Table 1-2 Component Type - Communications Systems Excluding distributed UFLS and distributed UVLS (see Table 3)		
Component Attributes	Maximum Maintenance Interval	Maintenance Activities
Any unmonitored communications system necessary for correct operation of protective functions, and not having all the monitoring attributes of a category below.	4 Calendar Months	Verify that the communications system is functional.
	6 Calendar Years	Verify that the communications system meets performance criteria pertinent to the communications technology applied (e.g. signal level, reflected power, or data error rate). Verify operation of communications system inputs and outputs that are essential to proper functioning of the Protection System.
Any communications system with continuous monitoring or periodic automated testing for the presence of the channel function, and alarming for loss of function (See Table 2).	12 Calendar Years	Verify that the communications system meets performance criteria pertinent to the communications technology applied (e.g. signal level, reflected power, or data error rate). Verify operation of communications system inputs and outputs that are essential to proper functioning of the Protection System.
Any communications system with all of the following: <ul style="list-style-type: none"> • Continuous monitoring or periodic automated testing for the performance of the channel using criteria pertinent to the communications technology applied (e.g. signal level, reflected power, or data error rate, and alarming for excessive performance degradation). (See Table 2) • Some or all binary or status inputs and control outputs are monitored by a process that continuously demonstrates ability to perform as designed, with alarming for failure (See Table 2). 	12 Calendar Years	Verify only the unmonitored communications system inputs and outputs that are essential to proper functioning of the Protection System

Table 1-3 Component Type - Voltage and Current Sensing Devices Providing Inputs to Protective Relays Excluding distributed UFLS and distributed UVLS (see Table 3)		
Component Attributes	Maximum Maintenance Interval	Maintenance Activities
Any voltage and current sensing devices not having monitoring attributes of the category below.	12 Calendar Years	Verify that current and voltage signal values are provided to the protective relays.
Voltage and Current Sensing devices connected to microprocessor relays with AC measurements are continuously verified by comparison of sensing input value, as measured by the microprocessor relay, to an independent ac measurement source, with alarming for unacceptable error or failure (see Table 2).	No periodic maintenance specified	None.

Table 1-4(a) Component Type – Protection System Station dc Supply Using Vented Lead-Acid (VLA) Batteries Excluding distributed UFLS and distributed UVLS (see Table 3)		
Protection System Station dc supply used only for non-BES interrupting devices for RAS, non-distributed UFLS systems, or non-distributed UVLS systems is excluded (see Table 1-4(e)).		
Component Attributes	Maximum Maintenance Interval	Maintenance Activities
Protection System Station dc supply using Vented Lead-Acid (VLA) batteries not having monitoring attributes of Table 1-4(f).	4 Calendar Months	Verify: <ul style="list-style-type: none"> • Station dc supply voltage Inspect: <ul style="list-style-type: none"> • Electrolyte level • For unintentional grounds
	18 Calendar Months	Verify: <ul style="list-style-type: none"> • Float voltage of battery charger • Battery continuity • Battery terminal connection resistance • Battery intercell or unit-to-unit connection resistance Inspect: <ul style="list-style-type: none"> • Cell condition of all individual battery cells where cells are visible – or measure battery cell/unit internal ohmic values where the cells are not visible • Physical condition of battery rack

<p style="text-align: center;">Table 1-4(a) Component Type – Protection System Station dc Supply Using Vented Lead-Acid (VLA) Batteries Excluding distributed UFLS and distributed UVLS (see Table 3)</p> <p style="text-align: center;">Protection System Station dc supply used only for non-BES interrupting devices for RAS, non-distributed UFLS systems, or non-distributed UVLS systems is excluded (see Table 1-4(e)).</p>		
Component Attributes	Maximum Maintenance Interval	Maintenance Activities
	18 Calendar Months -or- 6 Calendar Years	Verify that the station battery can perform as manufactured by evaluating cell/unit measurements indicative of battery performance (e.g. internal ohmic values or float current) against the station battery baseline. -or- Verify that the station battery can perform as manufactured by conducting a performance or modified performance capacity test of the entire battery bank.

Table 1-4(b) Component Type – Protection System Station dc Supply Using Valve-Regulated Lead-Acid (VRLA) Batteries Excluding distributed UFLS and distributed UVLS (see Table 3)		
Protection System Station dc supply used only for non-BES interrupting devices for RAS, non-distributed UFLS systems, or non-distributed UVLS systems is excluded (see Table 1-4(e)).		
Component Attributes	Maximum Maintenance Interval	Maintenance Activities
Protection System Station dc supply with Valve Regulated Lead-Acid (VRLA) batteries not having monitoring attributes of Table 1-4(f).	4 Calendar Months	Verify: <ul style="list-style-type: none"> • Station dc supply voltage Inspect: <ul style="list-style-type: none"> • For unintentional grounds
	6 Calendar Months	Inspect: <ul style="list-style-type: none"> • Condition of all individual units by measuring battery cell/unit internal ohmic values.
	18 Calendar Months	Verify: <ul style="list-style-type: none"> • Float voltage of battery charger • Battery continuity • Battery terminal connection resistance • Battery intercell or unit-to-unit connection resistance Inspect: <ul style="list-style-type: none"> • Physical condition of battery rack

<p style="text-align: center;">Table 1-4(b)</p> <p style="text-align: center;">Component Type – Protection System Station dc Supply Using Valve-Regulated Lead-Acid (VRLA) Batteries</p> <p style="text-align: center;">Excluding distributed UFLS and distributed UVLS (see Table 3)</p> <p style="text-align: center;">Protection System Station dc supply used only for non-BES interrupting devices for RAS, non-distributed UFLS systems, or non-distributed UVLS systems is excluded (see Table 1-4(e)).</p>		
Component Attributes	Maximum Maintenance Interval	Maintenance Activities
	6 Calendar Months -or- 3 Calendar Years	Verify that the station battery can perform as manufactured by evaluating cell/unit measurements indicative of battery performance (e.g. internal ohmic values or float current) against the station battery baseline. -or- Verify that the station battery can perform as manufactured by conducting a performance or modified performance capacity test of the entire battery bank.

Table 1-4(c) Component Type – Protection System Station dc Supply Using Nickel-Cadmium (NiCad) Batteries Excluding distributed UFLS and distributed UVLS (see Table 3)		
Protection System Station dc supply used only for non-BES interrupting devices for RAS, non-distributed UFLS system, or non-distributed UVLS systems is excluded (see Table 1-4(e)).		
Component Attributes	Maximum Maintenance Interval	Maintenance Activities
Protection System Station dc supply Nickel-Cadmium (NiCad) batteries not having monitoring attributes of Table 1-4(f).	4 Calendar Months	Verify: <ul style="list-style-type: none"> • Station dc supply voltage Inspect: <ul style="list-style-type: none"> • Electrolyte level • For unintentional grounds
	18 Calendar Months	Verify: <ul style="list-style-type: none"> • Float voltage of battery charger • Battery continuity • Battery terminal connection resistance • Battery intercell or unit-to-unit connection resistance Inspect: <ul style="list-style-type: none"> • Cell condition of all individual battery cells. • Physical condition of battery rack

Table 1-4(c) Component Type – Protection System Station dc Supply Using Nickel-Cadmium (NiCad) Batteries Excluding distributed UFLS and distributed UVLS (see Table 3)		
Protection System Station dc supply used only for non-BES interrupting devices for RAS, non-distributed UFLS system, or non-distributed UVLS systems is excluded (see Table 1-4(e)).		
Component Attributes	Maximum Maintenance Interval	Maintenance Activities
	6 Calendar Years	Verify that the station battery can perform as manufactured by conducting a performance or modified performance capacity test of the entire battery bank.

Table 1-4(d) Component Type – Protection System Station dc Supply Using Non Battery Based Energy Storage Excluding distributed UFLS and distributed UVLS (see Table 3)		
Protection System Station dc supply used only for non-BES interrupting devices for RAS, non-distributed UFLS system, or non-distributed UVLS systems is excluded (see Table 1-4(e)).		
Component Attributes	Maximum Maintenance Interval	Maintenance Activities
Any Protection System station dc supply not using a battery and not having monitoring attributes of Table 1-4(f).	4 Calendar Months	Verify: <ul style="list-style-type: none"> • Station dc supply voltage Inspect: <ul style="list-style-type: none"> • For unintentional grounds
	18 Calendar Months	Inspect: Condition of non-battery based dc supply
	6 Calendar Years	Verify that the dc supply can perform as manufactured when ac power is not present.

Table 1-4(e) Component Type – Protection System Station dc Supply for non-BES Interrupting Devices for RAS, non-distributed UFLS, and non-distributed UVLS systems		
Component Attributes	Maximum Maintenance Interval	Maintenance Activities
Any Protection System dc supply used for tripping only non-BES interrupting devices as part of a RAS, non-distributed UFLS, or non-distributed UVLS system and not having monitoring attributes of Table 1-4(f).	When control circuits are verified (See Table 1-5)	Verify Station dc supply voltage.

Table 1-4(f) Exclusions for Protection System Station dc Supply Monitoring Devices and Systems		
Component Attributes	Maximum Maintenance Interval	Maintenance Activities
Any station dc supply with high and low voltage monitoring and alarming of the battery charger voltage to detect charger overvoltage and charger failure (See Table 2).	No periodic maintenance specified	No periodic verification of station dc supply voltage is required.
Any battery based station dc supply with electrolyte level monitoring and alarming in every cell (See Table 2).		No periodic inspection of the electrolyte level for each cell is required.
Any station dc supply with unintentional dc ground monitoring and alarming (See Table 2).		No periodic inspection of unintentional dc grounds is required.
Any station dc supply with charger float voltage monitoring and alarming to ensure correct float voltage is being applied on the station dc supply (See Table 2).		No periodic verification of float voltage of battery charger is required.
Any battery based station dc supply with monitoring and alarming of battery string continuity (See Table 2).		No periodic verification of the battery continuity is required.
Any battery based station dc supply with monitoring and alarming of the intercell and/or terminal connection detail resistance of the entire battery (See Table 2).		No periodic verification of the intercell and terminal connection resistance is required.
Any Valve Regulated Lead-Acid (VRLA) or Vented Lead-Acid (VLA) station battery with internal ohmic value or float current monitoring and alarming, and evaluating present values relative to baseline internal ohmic values for every cell/unit (See Table 2).		No periodic evaluation relative to baseline of battery cell/unit measurements indicative of battery performance is required to verify the station battery can perform as manufactured.
Any Valve Regulated Lead-Acid (VRLA) or Vented Lead-Acid (VLA) station battery with monitoring and alarming of each cell/unit internal ohmic value (See Table 2).		No periodic inspection of the condition of all individual units by measuring battery cell/unit internal ohmic values of a station VRLA or Vented Lead-Acid (VLA) battery is required.

Table 1-5 Component Type - Control Circuitry Associated With Protective Functions Excluding distributed UFLS and distributed UVLS (see Table 3), Automatic Reclosing (see Table 4), and Sudden Pressure Relaying (see Table 5) Note: Table requirements apply to all Control Circuitry Components of Protection Systems, and RAS except as noted.		
Component Attributes	Maximum Maintenance Interval	Maintenance Activities
Trip coils or actuators of circuit breakers, interrupting devices, or mitigating devices (regardless of any monitoring of the control circuitry).	6 Calendar Years	Verify that each trip coil is able to operate the circuit breaker, interrupting device, or mitigating device.
Electromechanical lockout devices which are directly in a trip path from the protective relay to the interrupting device trip coil (regardless of any monitoring of the control circuitry).	6 Calendar Years	Verify electrical operation of electromechanical lockout devices.
Unmonitored control circuitry associated with RAS. (See Table 4-2(b) for RAS which include Automatic Reclosing.)	12 Calendar Years	Verify all paths of the control circuits essential for proper operation of the RAS.
Unmonitored control circuitry associated with protective functions inclusive of all auxiliary relays.	12 Calendar Years	Verify all paths of the trip circuits inclusive of all auxiliary relays through the trip coil(s) of the circuit breakers or other interrupting devices.
Control circuitry associated with protective functions and/or RAS whose integrity is monitored and alarmed (See Table 2).	No periodic maintenance specified	None.

Table 2 – Alarming Paths and Monitoring In Tables 1-1 through 1-5, Table 3, Tables 4-1 through 4-2, and Table 5 alarm attributes used to justify extended maximum maintenance intervals and/or reduced maintenance activities are subject to the following maintenance requirements		
Component Attributes	Maximum Maintenance Interval	Maintenance Activities
Any alarm path through which alarms in Tables 1-1 through 1-5, Table 3, Tables 4-1 through 4-2, and Table 5 are conveyed from the alarm origin to the location where corrective action can be initiated, and not having all the attributes of the “Alarm Path with monitoring” category below. Alarms are reported within 24 hours of detection to a location where corrective action can be initiated.	12 Calendar Years	Verify that the alarm path conveys alarm signals to a location where corrective action can be initiated.
Alarm Path with monitoring: The location where corrective action is taken receives an alarm within 24 hours for failure of any portion of the alarming path from the alarm origin to the location where corrective action can be initiated.	No periodic maintenance specified	None.

Table 3 Maintenance Activities and Intervals for distributed UFLS and distributed UVLS Systems		
Component Attributes	Maximum Maintenance Interval	Maintenance Activities
Any unmonitored protective relay not having all the monitoring attributes of a category below.	6 Calendar Years	<p>Verify that settings are as specified.</p> <p>For non-microprocessor relays:</p> <ul style="list-style-type: none"> • Test and, if necessary calibrate. <p>For microprocessor relays:</p> <ul style="list-style-type: none"> • Verify operation of the relay inputs and outputs that are essential to proper functioning of the Protection System. • Verify acceptable measurement of power system input values.
<p>Monitored microprocessor protective relay with the following:</p> <ul style="list-style-type: none"> • Internal self-diagnosis and alarming (See Table 2). • Voltage and/or current waveform sampling three or more times per power cycle, and conversion of samples to numeric values for measurement calculations by microprocessor electronics. <p>Alarming for power supply failure (See Table 2).</p>	12 Calendar Years	<p>Verify:</p> <ul style="list-style-type: none"> • Settings are as specified. • Operation of the relay inputs and outputs that are essential to proper functioning of the Protection System. • Acceptable measurement of power system input values
<p>Monitored microprocessor protective relay with preceding row attributes and the following:</p> <ul style="list-style-type: none"> • Ac measurements are continuously verified by comparison to an independent ac measurement source, with alarming for excessive error (See Table 2). 	12 Calendar Years	<p>Verify only the unmonitored relay inputs and outputs that are essential to proper functioning of the Protection System.</p>

Table 3 Maintenance Activities and Intervals for distributed UFLS and distributed UVLS Systems		
Component Attributes	Maximum Maintenance Interval	Maintenance Activities
<ul style="list-style-type: none"> Some or all binary or status inputs and control outputs are monitored by a process that continuously demonstrates ability to perform as designed, with alarming for failure (See Table 2). Alarming for change of settings (See Table 2).		
Voltage and/or current sensing devices associated with UFLS or UVLS systems.	12 Calendar Years	Verify that current and/or voltage signal values are provided to the protective relays.
Protection System dc supply for tripping non-BES interrupting devices used only for a UFLS or UVLS system.	12 Calendar Years	Verify Protection System dc supply voltage.
Control circuitry between the UFLS or UVLS relays and electromechanical lockout and/or tripping auxiliary devices (excludes non-BES interrupting device trip coils).	12 Calendar Years	Verify the path from the relay to the lockout and/or tripping auxiliary relay (including essential supervisory logic).
Electromechanical lockout and/or tripping auxiliary devices associated only with UFLS or UVLS systems (excludes non-BES interrupting device trip coils).	12 Calendar Years	Verify electrical operation of electromechanical lockout and/or tripping auxiliary devices.
Control circuitry between the electromechanical lockout and/or tripping auxiliary devices and the non-BES interrupting devices in UFLS or UVLS systems, or between UFLS or UVLS relays (with no interposing electromechanical lockout or auxiliary device) and the non-BES interrupting devices (excludes non-BES interrupting device trip coils).	No periodic maintenance specified	None.
Trip coils of non-BES interrupting devices in UFLS or UVLS systems.	No periodic maintenance specified	None.

Table 4-1 Maintenance Activities and Intervals for Automatic Reclosing Components Component Type – Reclosing Relay		
Component Attributes	Maximum Maintenance Interval	Maintenance Activities
Any unmonitored reclosing relay not having all the monitoring attributes of a category below.	6 Calendar Years	Verify that settings are as specified. For non-microprocessor relays: <ul style="list-style-type: none"> • Test and, if necessary calibrate For microprocessor relays: <ul style="list-style-type: none"> • Verify operation of the relay inputs and outputs that are essential to proper functioning of the Automatic Reclosing.
Monitored microprocessor reclosing relay with the following: <ul style="list-style-type: none"> • Internal self-diagnosis and alarming (See Table 2). • Alarming for power supply failure (See Table 2). 	12 Calendar Years	Verify: <ul style="list-style-type: none"> • Settings are as specified. • Operation of the relay inputs and outputs that are essential to proper functioning of the Automatic Reclosing.

Table 4-2(a) Maintenance Activities and Intervals for Automatic Reclosing Components Component Type – Control Circuitry Associated with Reclosing Relays that are NOT an Integral Part of an RAS		
Component Attributes	Maximum Maintenance Interval	Maintenance Activities
Unmonitored Control circuitry associated with Automatic Reclosing that is not an integral part of an RAS.	12 Calendar Years	Verify that Automatic Reclosing, upon initiation, does not issue a premature closing command to the close circuitry.
Control circuitry associated with Automatic Reclosing that is not part of an RAS and is monitored and alarmed for conditions that would result in a premature closing command. (See Table 2)	No periodic maintenance specified	None.

Table 4-2(b) Maintenance Activities and Intervals for Automatic Reclosing Components Component Type – Control Circuitry Associated with Reclosing Relays that ARE an Integral Part of an RAS		
Component Attributes	Maximum Maintenance Interval	Maintenance Activities
Close coils or actuators of circuit breakers or similar devices that are used in conjunction with Automatic Reclosing as part of an RAS (regardless of any monitoring of the control circuitry).	6 Calendar Years	Verify that each close coil or actuator is able to operate the circuit breaker or mitigating device.
Unmonitored close control circuitry associated with Automatic Reclosing used as an integral part of an RAS.	12 Calendar Years	Verify all paths of the control circuits associated with Automatic Reclosing that are essential for proper operation of the RAS.
Control circuitry associated with Automatic Reclosing that is an integral part of an RAS whose integrity is monitored and alarmed. (See Table 2)	No periodic maintenance specified	None.

<p style="text-align: center;">Table 5 Maintenance Activities and Intervals for Sudden Pressure Relaying</p> <p style="text-align: center;">Note: In cases where Components of Sudden Pressure Relaying are common to Components listed in Table 1-5, the Components only need to be tested once during a distinct maintenance interval.</p>		
Component Attributes	Maximum Maintenance Interval	Maintenance Activities
Any fault pressure relay.	6 Calendar Years	Verify the pressure or flow sensing mechanism is operable.
Electromechanical lockout devices which are directly in a trip path from the fault pressure relay to the interrupting device trip coil (regardless of any monitoring of the control circuitry).	6 Calendar Years	Verify electrical operation of electromechanical lockout devices.
Unmonitored control circuitry associated with Sudden Pressure Relaying.	12 Calendar Years	Verify all paths of the trip circuits inclusive of all auxiliary relays through the trip coil(s) of the circuit breakers or other interrupting devices.
Control circuitry associated with Sudden Pressure Relaying whose integrity is monitored and alarmed (See Table 2).	No periodic maintenance specified	None.

PRC-005 — Attachment A

Criteria for a Performance-Based Protection System Maintenance Program

Purpose: To establish a technical basis for initial and continued use of a performance-based Protection System Maintenance Program (PSMP).

To establish the technical justification for the initial use of a performance-based PSMP:

1. Develop a list with a description of Components included in each designated Segment, with a minimum Segment population of 60 Components.
2. Maintain the Components in each Segment according to the time-based maximum allowable intervals established in Tables 1-1 through 1-5, Table 3, Tables 4-1 through 4-2, and Table 5 until results of maintenance activities for the Segment are available for a minimum of 30 individual Components of the Segment.
3. Document the maintenance program activities and results for each Segment, including maintenance dates and Countable Events for each included Component.
4. Analyze the maintenance program activities and results for each Segment to determine the overall performance of the Segment and develop maintenance intervals.
5. Determine the maximum allowable maintenance interval for each Segment such that the Segment experiences Countable Events on no more than 4% of the Components within the Segment, for the greater of either the last 30 Components maintained or all Components maintained in the previous year.

To maintain the technical justification for the ongoing use of a performance-based PSMP:

1. At least annually, update the list of Components and Segments and/or description if any changes occur within the Segment.
2. Perform maintenance on the greater of 5% of the Components (addressed in the performance based PSMP) in each Segment or 3 individual Components within the Segment in each year.
3. For the prior year, analyze the maintenance program activities and results for each Segment to determine the overall performance of the Segment.
4. Using the prior year's data, determine the maximum allowable maintenance interval for each Segment such that the Segment experiences Countable Events on no more than 4% of the Components within the Segment, for the greater of either the last 30 Components maintained or all Components maintained in the previous year.

If the Components in a Segment maintained through a performance-based PSMP experience 4% or more Countable Events, develop, document, and implement an action plan to reduce the Countable Events to less than 4% of the Segment population within 3 years.

Rationale:

During development of this standard, text boxes were embedded within the standard to explain the rationale for various parts of the standard. Upon BOT approval, the text from the rationale text boxes was moved to this section.

Rationale for Applicability Section:

This section does not reflect the applicability changes that will be proposed by the Project 2014-01 Standards Applicability for Dispersed Generation Resources standards drafting team. The changes in this posted version and those being made by the Project 2014-01 standards drafting team do not overlap.

Additionally, to align with ongoing NERC standards development in Project 2010-05.2: Special Protection Systems, the term “Special Protection Systems” in PRC-005-4 was replaced by the term “Remedial Action Schemes.” These terms are synonymous in the NERC Glossary of Terms.

Rationale for the deletion of part of the definition of Component:

The SDT determined that it was explanatory in nature and adequately addressed in the Supplementary Reference and FAQ Document.

Rationale for R3 Part 3.1:

In the last posting, the SDT included language in the standard that was originally in the implementation plan that required completion of maintenance activities within three years for newly-identified Automatic Reclosing Components following a notification under Requirement R6, which has been removed. After further discussion, the SDT determined that a separate shorter timeframe for maintenance of newly-identified Automatic Reclosing Components created unnecessary complication within the standard. The SDT agreed that entities should be responsible for maintaining the Automatic Reclosing Components subject to the standard, whether existing, newly added or newly within scope based on a change in the largest generating unit in the BA or, if a member of a Reserve Sharing Group, the largest generating unit within the Reserve Sharing Group according to the timeframes in the maintenance tables. Therefore, 3.1 and its subparts have been removed and have not been reinserted into the implementation plan.

Rationale for R4 Part 4.1:

In the last posting, the SDT included language in the standard that was originally in the implementation plan that required completion of maintenance activities within three years for newly-identified Automatic Reclosing Components following a notification under Requirement R6, which has been removed. After further discussion, the SDT determined that a separate shorter timeframe for maintenance of newly-identified Automatic Reclosing Components created unnecessary complication within the standard. The SDT agreed that entities should be responsible for maintaining the Automatic Reclosing Components subject to the standard, whether existing, newly added or newly within scope based on a change in the largest generating unit in the BA or, if a member of a Reserve Sharing Group, the largest generating

unit within the Reserve Sharing Group according to the timeframes in the maintenance tables. Therefore, 4.1 and its subparts have been removed and have not been reinserted into the implementation plan.

Standard Development Timeline

This section is maintained by the drafting team during the development of the standard and will be removed when the standard becomes effective.

Development Steps Completed

1. SAR posted for comment November 20, 2013 – December 19, 2013.
2. An earlier draft of this standard was posted for a 45-day comment and ballot period June 12, 2014–July 29, 2014.
3. PRC-005-3(X) passed a final ballot, which was posted for a 10-day ballot period of August 27, 2014-September 5, 2014.
4. PRC-005-5 passed an initial ballot, which was posted for a 45-day Formal Comment Period with Parallel Ballot December 8, 2014 – January 22, 2015.

Description of Current Draft

The Dispersed Generation Resources Standard Drafting Team (DGR SDT) is posting this version of PRC-005 for final ballot under the new Standards Process Manual (Effective: June 26, 2013). This version includes all substantive changes recently approved by the NERC Board of Trustees in addition to applicability changes recommended by the DGR SDT.

Anticipated Actions	Anticipated Dates
45-day Formal Comment Period with Parallel Ballot	December 8, 2014 – January 22, 2015
Final ballot	March 2015
BOT adoption	May 2015

Definitions of Terms Used in Standard

This section includes all newly defined or revised terms used in the proposed standard. Terms already defined in the Reliability Standards Glossary of Terms (Glossary) are not repeated here. New or revised definitions listed below become approved when the proposed standard is approved. When the standard becomes effective, this defined term will be removed from the individual standard and added to the Glossary.

None.

A. Introduction

1. **Title:** Protection System, Automatic Reclosing, and Sudden Pressure Relaying Maintenance
2. **Number:** PRC-005-5
3. **Purpose:** To document and implement programs for the maintenance of all Protection Systems, Automatic Reclosing, and Sudden Pressure Relaying affecting the reliability of the Bulk Electric System (BES) so that they are kept in working order.

4. **Applicability:**

- 4.1. **Functional Entities:**

- 4.1.1 Transmission Owner
 - 4.1.2 Generator Owner
 - 4.1.3 Distribution Provider

- 4.2. **Facilities:**

- 4.2.1 Protection Systems and Sudden Pressure Relaying that are installed for the purpose of detecting Faults on BES Elements (lines, buses, transformers, etc.)
 - 4.2.2 Protection Systems used for underfrequency load-shedding systems installed per ERO underfrequency load-shedding requirements.
 - 4.2.3 Protection Systems used for undervoltage load-shedding systems installed to prevent system voltage collapse or voltage instability for BES reliability.
 - 4.2.4 Protection Systems installed as a Remedial Action Scheme (RAS) for BES reliability.

- 4.2.5 Protection Systems and Sudden Pressure Relaying for generator Facilities that are part of the BES, except for generators ~~not~~ identified through Inclusion I4 of the BES definition, including:

- 4.2.5.1 Protection Systems that act to trip the generator either directly or via lockout or auxiliary tripping relays.

- 4.2.5.2 Protection Systems and Sudden Pressure Relaying for generator step-up transformers for generators that are part of the BES.

Rationale for section 4.2.5: These applicability revisions are intended to clarify and provide for consistent application of the Requirements to BES generator Facilities included in the BES through Inclusion I4 – Dispersed Power Producing Resources. The SDT modified the language for clarity based on comments received and is not changing the intent of the standard modification from the last posted version of this standard.

4.2.5.24.2.5.3 Protection Systems and Sudden Pressure Relaying for station service or excitation transformers connected to the generator bus of generators which are part of the BES, that act to trip the generator either directly or via lockout or tripping auxiliary relays.

4.2.6 Protection Systems and Sudden Pressure Relaying for the following BES generator Facilities for dispersed power producing resources identified through Inclusion I4 of the BES definition:

4.2.6.1 Protection Systems and Sudden Pressure Relaying for Facilities used in aggregating dispersed BES generation from the point where those resources aggregate to greater than 75 MVA to a common point of connection at 100kV or above.

4.2.7 Automatic Reclosing,¹ including:

4.2.7.1 Automatic Reclosing applied on the terminals of Elements connected to the BES bus located at generating plant substations where the total installed gross generating plant capacity is greater than the gross capacity of the largest BES generating unit within the Balancing Authority Area or, if a member of a Reserve Sharing Group, the largest generating unit within the Reserve Sharing Group.²

4.2.7.2 Automatic Reclosing applied on the terminals of all BES Elements at substations one bus away from generating plants specified in Section 4.2.7.1 when the substation is less than 10 circuit-miles from the generating plant substation.

4.2.7.3. Automatic Reclosing applied as an integral part of an RAS specified in Section 4.2.4.

5. Effective Date: See the Implementation Plan for this standard.

6. Definitions Used in this Standard:

Automatic Reclosing – Includes the following Components:

- Reclosing relay
- Control circuitry associated with the reclosing relay.

¹ Automatic Reclosing addressed in Section 4.2.7.1 and 4.2.7.2~~3~~ may be excluded if the equipment owner can demonstrate that a close-in three-phase fault present for twice the normal clearing time (capturing a minimum trip-close-trip time delay) does not result in a total loss of gross generation in the Interconnection exceeding the gross capacity of the largest relevant BES generating unit where the Automatic Reclosing is applied.

² The largest BES generating unit within the Balancing Authority Area or the largest generating unit within the Reserve Sharing Group, as applicable, is subject to change. As a result of such a change, the Automatic Reclosing Components subject to the standard could change effective on the date of such change.

Sudden Pressure Relaying – A system that trips an interrupting device(s) to isolate the equipment it is monitoring and includes the following Components:

- Fault pressure relay – a mechanical relay or device that detects rapid changes in gas pressure, oil pressure, or oil flow that are indicative of Faults within liquid-filled, wire-wound equipment
- Control circuitry associated with a fault pressure relay

Unresolved Maintenance Issue – A deficiency identified during a maintenance activity that causes the Component to not meet the intended performance, cannot be corrected during the maintenance interval, and requires follow-up corrective action.

Segment – Components of a consistent design standard, or a particular model or type from a single manufacturer that typically share other common elements. Consistent performance is expected across the entire population of a Segment. A Segment must contain at least sixty (60) individual Components.

Component Type –

- Any one of the five specific elements of a Protection System.
- Any one of the two specific elements of Automatic Reclosing.
- Any one of the two specific elements of Sudden Pressure Relaying.

Component – Any individual discrete piece of equipment included in a Protection System, Automatic Reclosing, or Sudden Pressure Relaying.

Countable Event – A failure of a Component requiring repair or replacement, any condition discovered during the maintenance activities in Tables 1-1 through 1-5, Table 3, Tables 4-1 through 4-2, and Table 5, which requires corrective action or a Protection System Misoperation attributed to hardware failure or calibration failure. Misoperations due to product design errors, software errors, relay settings different from specified settings, Protection System Component, Automatic Reclosing, or Sudden Pressure Relaying configuration or application errors are not included in Countable Events.

B. Requirements and Measures

- R1.** Each Transmission Owner, Generator Owner, and Distribution Provider shall establish a Protection System Maintenance Program (PSMP) for its Protection Systems, Automatic Reclosing, and Sudden Pressure Relaying identified in Section 4.2, Facilities. *[Violation Risk Factor: Medium] [Time Horizon: Operations Planning]*

The PSMP shall:

- 1.1.** Identify which maintenance method (time-based, performance-based per PRC-005 Attachment A, or a combination) is used to address each Protection System,

Automatic Reclosing, and Sudden Pressure Relaying Component Type. All batteries associated with the station dc supply Component Type of a Protection System shall be included in a time-based program as described in Table 1-4 and Table 3.

- 1.2.** Include the applicable monitored Component attributes applied to each Protection System, Automatic Reclosing, and Sudden Pressure Relaying Component Type consistent with the maintenance intervals specified in Tables 1-1 through 1-5, Table 2, Table 3, Table 4-1 through 4-2, and Table 5 where monitoring is used to extend the maintenance intervals beyond those specified for unmonitored Protection System, Automatic Reclosing, and Sudden Pressure Relaying Components.
- M1.** Each Transmission Owner, Generator Owner and Distribution Provider shall have a documented Protection System Maintenance Program in accordance with Requirement R1.
- For each Protection System, Automatic Reclosing, and Sudden Pressure Relaying Component Type, the documentation shall include the type of maintenance method applied (time-based, performance-based, or a combination of these maintenance methods), and shall include all batteries associated with the station dc supply Component Types in a time-based program as described in Table 1-4 and Table 3. (Part 1.1)
- For Component Types that use monitoring to extend the maintenance intervals, the responsible entity(s) shall have evidence for each Protection System, Automatic Reclosing, and Sudden Pressure Relaying Component Type (such as manufacturer's specifications or engineering drawings) of the appropriate monitored Component attributes as specified in Tables 1-1 through 1-5, Table 2, Table 3, Table 4-1 through 4-2, and Table 5. (Part 1.2)
- R2.** Each Transmission Owner, Generator Owner, and Distribution Provider that uses performance-based maintenance intervals in its PSMP shall follow the procedure established in PRC-005 Attachment A to establish and maintain its performance-based intervals. [*Violation Risk Factor: Medium*] [*Time Horizon: Operations Planning*]
- M2.** Each Transmission Owner, Generator Owner, and Distribution Provider that uses performance-based maintenance intervals shall have evidence that its current performance-based maintenance program(s) is in accordance with Requirement R2, which may include, but is not limited to, Component lists, dated maintenance records, and dated analysis records and results.
- R3.** Each Transmission Owner, Generator Owner, and Distribution Provider that utilizes time-based maintenance program(s) shall maintain its Protection System, Automatic Reclosing, and Sudden Pressure Relaying Components that are included within the time-based maintenance program in accordance with the minimum maintenance activities and maximum maintenance intervals prescribed within Tables 1-1 through

1-5, Table 2, Table 3, Table 4-1 through 4-2, and Table 5. *[Violation Risk Factor: High]*
[Time Horizon: Operations Planning]

- M3.** Each Transmission Owner, Generator Owner, and Distribution Provider that utilizes time-based maintenance program(s) shall have evidence that it has maintained its Protection System, Automatic Reclosing, and Sudden Pressure Relaying Components included within its time-based program in accordance with Requirement R3. The evidence may include, but is not limited to, dated maintenance records, dated maintenance summaries, dated check-off lists, dated inspection records, or dated work orders.
- R4.** Each Transmission Owner, Generator Owner, and Distribution Provider that utilizes performance-based maintenance program(s) in accordance with Requirement R2 shall implement and follow its PSMP for its Protection System, Automatic Reclosing, and Sudden Pressure Relaying Components that are included within the performance-based program(s). *[Violation Risk Factor: High]* *[Time Horizon: Operations Planning]*
- M4.** Each Transmission Owner, Generator Owner, and Distribution Provider that utilizes performance-based maintenance intervals in accordance with Requirement R2 shall have evidence that it has implemented the Protection System Maintenance Program for the Protection System, Automatic Reclosing, and Sudden Pressure Relaying Components included in its performance-based program in accordance with Requirement R4. The evidence may include, but is not limited to, dated maintenance records, dated maintenance summaries, dated check-off lists, dated inspection records, or dated work orders.
- R5.** Each Transmission Owner, Generator Owner, and Distribution Provider shall demonstrate efforts to correct identified Unresolved Maintenance Issues. *[Violation Risk Factor: Medium]* *[Time Horizon: Operations Planning]*
- M5.** Each Transmission Owner, Generator Owner, and Distribution Provider shall have evidence that it has undertaken efforts to correct identified Unresolved Maintenance Issues in accordance with Requirement R5. The evidence may include, but is not limited to, work orders, replacement Component orders, invoices, project schedules with completed milestones, return material authorizations (RMAs) or purchase orders.

C. Compliance

1. Compliance Monitoring Process

1.1. Compliance Enforcement Authority

As defined in the NERC Rules of Procedure, “Compliance Enforcement Authority” means NERC or the Regional Entity in their respective roles of monitoring and enforcing compliance with the NERC Reliability Standards.

1.2. Evidence Retention

The following evidence retention periods identify the period of time an entity is required to retain specific evidence to demonstrate compliance. For instances where the evidence retention period specified below is shorter than the time since the last audit, the Compliance Enforcement Authority may ask an entity to provide other evidence to show that it was compliant for the full time period since the last audit.

The Transmission Owner, Generator Owner, and Distribution Provider shall each keep data or evidence to show compliance as identified below unless directed by its Compliance Enforcement Authority to retain specific evidence for a longer period of time as part of an investigation.

For Requirement R1, the Transmission Owner, Generator Owner, and Distribution Provider shall each keep its current dated Protection System Maintenance Program, as well as any superseded versions since the preceding compliance audit, including the documentation that specifies the type of maintenance program applied for each Protection System, Automatic Reclosing, or Sudden Pressure Relaying Component Type.

For Requirement R2, Requirement R3, and Requirement R4, in cases where the interval of the maintenance activity is longer than the audit cycle, the Transmission Owner, Generator Owner, and Distribution Provider shall each keep documentation of the most recent performance of that maintenance activity for the Protection System, Automatic Reclosing, or Sudden Pressure Relaying Component. In cases where the interval of the maintenance activity is shorter than the audit cycle, documentation of all performances (in accordance with the tables) of that maintenance activity for the Protection System, Automatic Reclosing, or Sudden Pressure Relaying Component since the previous scheduled audit date shall be retained.

For Requirement R5 the Transmission Owner, Generator Owner, and Distribution Provider shall each keep documentation of Unresolved Maintenance Issues identified by the entity since the last audit, including all that were resolved since the last audit.

The Compliance Enforcement Authority shall keep the last audit records and all requested and submitted subsequent audit records.

1.3. Compliance Monitoring and Assessment Processes:

Compliance Audits

Self-Certifications

Spot Checking

Compliance Violation Investigations

Self-Reporting

Complaints

1.4. Additional Compliance Information

None

Table of Compliance Elements

Requirement Number	Lower VSL	Moderate VSL	High VSL	Severe VSL
R1	The entity's PSMP failed to specify whether one Component Type is being addressed by time-based or performance-based maintenance, or a combination of both (Part 1.1).	The entity's PSMP failed to specify whether two Component Types are being addressed by time-based or performance-based maintenance, or a combination of both (Part 1.1).	<p>The entity's PSMP failed to specify whether three Component Types are being addressed by time-based or performance-based maintenance, or a combination of both. (Part 1.1).</p> <p>OR</p> <p>The entity's PSMP failed to include the applicable monitoring attributes applied to each Component Type consistent with the maintenance intervals specified in Tables 1-1 through 1-5, Table 2, Table 3, Tables 4-1 through 4-2, and Table 5 where monitoring is used to extend the maintenance intervals beyond those specified for unmonitored Components (Part 1.2).</p>	<p>The entity failed to establish a PSMP.</p> <p>OR</p> <p>The entity's PSMP failed to specify whether four or more Component Types are being addressed by time-based or performance-based maintenance, or a combination of both (Part 1.1).</p> <p>OR</p> <p>The entity's PSMP failed to include applicable station batteries in a time-based program (Part 1.1).</p>
R2	The entity uses performance-based maintenance intervals in its PSMP but failed to reduce Countable Events to no more than 4% within three years.	NA	The entity uses performance-based maintenance intervals in its PSMP but failed to reduce Countable Events to no more than 4% within four years.	<p>The entity uses performance-based maintenance intervals in its PSMP but:</p> <ol style="list-style-type: none"> 1) Failed to establish the technical justification described within Requirement R2 for the initial use of the performance-based PSMP <p>OR</p> <ol style="list-style-type: none"> 2) Failed to reduce Countable Events to no more than 4% within five years <p>OR</p>

Requirement Number	Lower VSL	Moderate VSL	High VSL	Severe VSL
				3) Maintained a Segment with less than 60 Components OR 4) Failed to: <ul style="list-style-type: none"> • Annually update the list of Components, OR • Annually perform maintenance on the greater of 5% of the Segment population or 3 Components, OR • Annually analyze the program activities and results for each Segment.
R3	For Components included within a time-based maintenance program, the entity failed to maintain 5% or less of the total Components included within a specific Component Type in accordance with the minimum maintenance activities and maximum maintenance intervals prescribed within Tables 1-1 through 1-5, Table 2, Table 3, Tables 4-1 through 4-2, and Table 5.	For Components included within a time-based maintenance program, the entity failed to maintain more than 5% but 10% or less of the total Components included within a specific Component Type in accordance with the minimum maintenance activities and maximum maintenance intervals prescribed within Tables 1-1 through 1-5, Table 2, Table 3, Tables 4-1 through 4-2, and Table 5.	For Components included within a time-based maintenance program, the entity failed to maintain more than 10% but 15% or less of the total Components included within a specific Component Type in accordance with the minimum maintenance activities and maximum maintenance intervals prescribed within Tables 1-1 through 1-5, Table 2, Table 3, Tables 4-1 through 4-2, and Table 5.	For Components included within a time-based maintenance program, the entity failed to maintain more than 15% of the total Components included within a specific Component Type in accordance with the minimum maintenance activities and maximum maintenance intervals prescribed within Tables 1-1 through 1-5, Table 2, Table 3, Tables 4-1 through 4-2, and Table 5.

Requirement Number	Lower VSL	Moderate VSL	High VSL	Severe VSL
R4	For Components included within a performance-based maintenance program, the entity failed to maintain 5% or less of the annual scheduled maintenance for a specific Component Type in accordance with their performance-based PSMP.	For Components included within a performance-based maintenance program, the entity failed to maintain more than 5% but 10% or less of the annual scheduled maintenance for a specific Component Type in accordance with their performance-based PSMP.	For Components included within a performance-based maintenance program, the entity failed to maintain more than 10% but 15% or less of the annual scheduled maintenance for a specific Component Type in accordance with their performance-based PSMP.	For Components included within a performance-based maintenance program, the entity failed to maintain more than 15% of the annual scheduled maintenance for a specific Component Type in accordance with their performance-based PSMP.
R5	The entity failed to undertake efforts to correct 5 or fewer identified Unresolved Maintenance Issues.	The entity failed to undertake efforts to correct greater than 5 but less than or equal to 10 identified Unresolved Maintenance Issues.	The entity failed to undertake efforts to correct greater than 10 but less than or equal to 15 identified Unresolved Maintenance Issues.	The entity failed to undertake efforts to correct greater than 15 identified Unresolved Maintenance Issues.

D. Regional Variances

None.

E. Interpretations

None.

Supplemental Reference Documents

The following documents present a detailed discussion about determination of maintenance intervals and other useful information regarding establishment of a maintenance program.

1. *Supplementary Reference and FAQ - PRC-005-4 Protection System Maintenance*, Protection System Maintenance and Testing Standard Drafting Team (April 2014)
2. *Considerations for Maintenance and Testing of Auto-reclosing Schemes*, NERC System Analysis and Modeling Subcommittee, and NERC System Protection and Control Subcommittee (November 2012)
3. *Sudden Pressure Relays and Other Devices that Respond to Non-Electrical Quantities – SPCS Input for Standard Development in Response to FERC Order No. 758*, NERC System Protection and Control Subcommittee (December 2013)

Version History

Version	Date	Action	Change Tracking
0	February 8, 2005	Adopted by NERC Board of Trustees	New
1	February 7, 2006	Adopted by NERC Board of Trustees	<ol style="list-style-type: none"> 1. Changed incorrect use of certain hyphens (-) to “en dash” (–) and “em dash (—).” 2. Added “periods” to items where appropriate. Changed “Timeframe” to “Time Frame” in item D, 1.2.
1a	February 17, 2011	Adopted by NERC Board of Trustees	Added Appendix 1 - Interpretation regarding applicability of standard to protection of radially connected transformers developed in Project 2009-17
1b	November 5, 2009	Adopted by NERC Board of Trustees	Interpretation of R1, R1.1, and R1.2 developed by Project 2009-10
1b	February 3, 2012	FERC Order approving revised definition of “Protection System”	Per footnote 8 of FERC’s order, the definition of “Protection

Version	Date	Action	Change Tracking
			System” supersedes interpretation “b” of PRC-005-1b upon the effective date of the modified definition (i.e., April 1, 2013) <i>See N. Amer. Elec. Reliability Corp.</i> , 138 FERC ¶ 61,095 (February 3, 2012).
1.1b	May 9, 2012	Adopted by NERC Board of Trustees	Errata change developed by Project 2010-07, clarified inclusion of generator interconnection Facility in Generator Owner’s responsibility

Version	Date	Action	Change Tracking
2	November 7, 2012	Adopted by NERC Board of Trustees	Project 2007-17 - Complete revision, absorbing maintenance requirements from PRC-005-1.1b, PRC-008-0, PRC-011-0, PRC-017-0
2	October 17, 2013	Approved by NERC Standards Committee	Errata Change: The Standards Committee approved an errata change to the implementation plan for PRC-005-2 to add the phrase “or as otherwise made effective pursuant to the laws applicable to such ERO governmental authorities;” to the second sentence under the “Retirement of Existing Standards” section. (no change to standard version number)
2	March 7, 2014	Adopted by NERC Board of Trustees	Modified R1 VSL in response to FERC directive (no change to standard version number)
2(i)	November 13, 2014	Adopted by NERC Board of Trustees	Applicability section revised by Project 2014-01 to clarify application of Requirements to BES dispersed power producing resources
2(ii)	November 13, 2014	Adopted by NERC Board of Trustees	Replaced references to Special Protection System and SPS with Remedial Action Scheme and RAS
3	November 7, 2013	Adopted by the NERC Board of Trustees	Revised to address the FERC directive in Order No. 758 to include Automatic Reclosing in maintenance programs

Version	Date	Action	Change Tracking
3	February 12, 2014	Approved by NERC Standards Committee	Errata Change: The Standards Committee approved errata changes to correct capitalization of certain defined terms within the definitions of “Unresolved Maintenance Issue” and “Protection System Maintenance Program”. The changes will be reflected in the definitions section of PRC-005-3 for “Unresolved Maintenance Issue” and in the NERC Glossary of Terms for “Protection System Maintenance Program”. (no change to standard version number)
3	March 7, 2014	Adopted by NERC Board of Trustees	Modified R1 VSL in response to FERC directive (no change to standard version number)
3(i)	November 13, 2014	Adopted by NERC Board of Trustees	Applicability section revised by Project 2014-01 to clarify application of Requirements to BES dispersed power producing resources
3(ii)	November 13, 2014	Adopted by NERC Board of Trustees	Replaced references to Special Protection System and SPS with Remedial Action Scheme and RAS
4	November 13, 2014	Adopted by NERC Board of Trustees	Added Sudden Pressure Relaying in response to FERC Order No. 758

Table 1-1 Component Type - Protective Relay Excluding distributed UFLS and distributed UVLS (see Table 3)		
Component Attributes	Maximum Maintenance Interval ³	Maintenance Activities
Any unmonitored protective relay not having all the monitoring attributes of a category below.	6 Calendar Years	For all unmonitored relays: <ul style="list-style-type: none"> • Verify that settings are as specified For non-microprocessor relays: <ul style="list-style-type: none"> • Test and, if necessary calibrate For microprocessor relays: <ul style="list-style-type: none"> • Verify operation of the relay inputs and outputs that are essential to proper functioning of the Protection System. • Verify acceptable measurement of power system input values.
Monitored microprocessor protective relay with the following: <ul style="list-style-type: none"> • Internal self-diagnosis and alarming (see Table 2). • Voltage and/or current waveform sampling three or more times per power cycle, and conversion of samples to numeric values for measurement calculations by microprocessor electronics. • Alarming for power supply failure (see Table 2). 	12 Calendar Years	Verify: <ul style="list-style-type: none"> • Settings are as specified. • Operation of the relay inputs and outputs that are essential to proper functioning of the Protection System. • Acceptable measurement of power system input values.

³ For the tables in this standard, a calendar year starts on the first day of a new year (January 1) after a maintenance activity has been completed. For the tables in this standard, a calendar month starts on the first day of the first month after a maintenance activity has been completed.

Table 1-1 Component Type - Protective Relay Excluding distributed UFLS and distributed UVLS (see Table 3)		
Component Attributes	Maximum Maintenance Interval ³	Maintenance Activities
Monitored microprocessor protective relay with preceding row attributes and the following: <ul style="list-style-type: none"> • Ac measurements are continuously verified by comparison to an independent ac measurement source, with alarming for excessive error (See Table 2). • Some or all binary or status inputs and control outputs are monitored by a process that continuously demonstrates ability to perform as designed, with alarming for failure (See Table 2). • Alarming for change of settings (See Table 2). 	12 Calendar Years	Verify only the unmonitored relay inputs and outputs that are essential to proper functioning of the Protection System.

Table 1-2 Component Type - Communications Systems Excluding distributed UFLS and distributed UVLS (see Table 3)		
Component Attributes	Maximum Maintenance Interval	Maintenance Activities
Any unmonitored communications system necessary for correct operation of protective functions, and not having all the monitoring attributes of a category below.	4 Calendar Months	Verify that the communications system is functional.
	6 Calendar Years	Verify that the communications system meets performance criteria pertinent to the communications technology applied (e.g. signal level, reflected power, or data error rate). Verify operation of communications system inputs and outputs that are essential to proper functioning of the Protection System.
Any communications system with continuous monitoring or periodic automated testing for the presence of the channel function, and alarming for loss of function (See Table 2).	12 Calendar Years	Verify that the communications system meets performance criteria pertinent to the communications technology applied (e.g. signal level, reflected power, or data error rate). Verify operation of communications system inputs and outputs that are essential to proper functioning of the Protection System.
Any communications system with all of the following: <ul style="list-style-type: none"> • Continuous monitoring or periodic automated testing for the performance of the channel using criteria pertinent to the communications technology applied (e.g. signal level, reflected power, or data error rate, and alarming for excessive performance degradation). (See Table 2) • Some or all binary or status inputs and control outputs are monitored by a process that continuously demonstrates ability to perform as designed, with alarming for failure (See Table 2). 	12 Calendar Years	Verify only the unmonitored communications system inputs and outputs that are essential to proper functioning of the Protection System

Table 1-3 Component Type - Voltage and Current Sensing Devices Providing Inputs to Protective Relays Excluding distributed UFLS and distributed UVLS (see Table 3)		
Component Attributes	Maximum Maintenance Interval	Maintenance Activities
Any voltage and current sensing devices not having monitoring attributes of the category below.	12 Calendar Years	Verify that current and voltage signal values are provided to the protective relays.
Voltage and Current Sensing devices connected to microprocessor relays with AC measurements are continuously verified by comparison of sensing input value, as measured by the microprocessor relay, to an independent ac measurement source, with alarming for unacceptable error or failure (see Table 2).	No periodic maintenance specified	None.

Table 1-4(a) Component Type – Protection System Station dc Supply Using Vented Lead-Acid (VLA) Batteries Excluding distributed UFLS and distributed UVLS (see Table 3)		
Protection System Station dc supply used only for non-BES interrupting devices for RAS, non-distributed UFLS systems, or non-distributed UVLS systems is excluded (see Table 1-4(e)).		
Component Attributes	Maximum Maintenance Interval	Maintenance Activities
Protection System Station dc supply using Vented Lead-Acid (VLA) batteries not having monitoring attributes of Table 1-4(f).	4 Calendar Months	Verify: <ul style="list-style-type: none"> • Station dc supply voltage Inspect: <ul style="list-style-type: none"> • Electrolyte level • For unintentional grounds
	18 Calendar Months	Verify: <ul style="list-style-type: none"> • Float voltage of battery charger • Battery continuity • Battery terminal connection resistance • Battery intercell or unit-to-unit connection resistance Inspect: <ul style="list-style-type: none"> • Cell condition of all individual battery cells where cells are visible – or measure battery cell/unit internal ohmic values where the cells are not visible • Physical condition of battery rack

<p style="text-align: center;">Table 1-4(a) Component Type – Protection System Station dc Supply Using Vented Lead-Acid (VLA) Batteries Excluding distributed UFLS and distributed UVLS (see Table 3)</p> <p style="text-align: center;">Protection System Station dc supply used only for non-BES interrupting devices for RAS, non-distributed UFLS systems, or non-distributed UVLS systems is excluded (see Table 1-4(e)).</p>		
Component Attributes	Maximum Maintenance Interval	Maintenance Activities
	18 Calendar Months -or- 6 Calendar Years	Verify that the station battery can perform as manufactured by evaluating cell/unit measurements indicative of battery performance (e.g. internal ohmic values or float current) against the station battery baseline. -or- Verify that the station battery can perform as manufactured by conducting a performance or modified performance capacity test of the entire battery bank.

Table 1-4(b) Component Type – Protection System Station dc Supply Using Valve-Regulated Lead-Acid (VRLA) Batteries Excluding distributed UFLS and distributed UVLS (see Table 3)		
Protection System Station dc supply used only for non-BES interrupting devices for RAS, non-distributed UFLS systems, or non-distributed UVLS systems is excluded (see Table 1-4(e)).		
Component Attributes	Maximum Maintenance Interval	Maintenance Activities
Protection System Station dc supply with Valve Regulated Lead-Acid (VRLA) batteries not having monitoring attributes of Table 1-4(f).	4 Calendar Months	Verify: <ul style="list-style-type: none"> • Station dc supply voltage Inspect: <ul style="list-style-type: none"> • For unintentional grounds
	6 Calendar Months	Inspect: <ul style="list-style-type: none"> • Condition of all individual units by measuring battery cell/unit internal ohmic values.
	18 Calendar Months	Verify: <ul style="list-style-type: none"> • Float voltage of battery charger • Battery continuity • Battery terminal connection resistance • Battery intercell or unit-to-unit connection resistance Inspect: <ul style="list-style-type: none"> • Physical condition of battery rack

<p align="center">Table 1-4(b)</p> <p align="center">Component Type – Protection System Station dc Supply Using Valve-Regulated Lead-Acid (VRLA) Batteries</p> <p align="center">Excluding distributed UFLS and distributed UVLS (see Table 3)</p> <p align="center">Protection System Station dc supply used only for non-BES interrupting devices for RAS, non-distributed UFLS systems, or non-distributed UVLS systems is excluded (see Table 1-4(e)).</p>		
Component Attributes	Maximum Maintenance Interval	Maintenance Activities
	6 Calendar Months -or- 3 Calendar Years	Verify that the station battery can perform as manufactured by evaluating cell/unit measurements indicative of battery performance (e.g. internal ohmic values or float current) against the station battery baseline. -or- Verify that the station battery can perform as manufactured by conducting a performance or modified performance capacity test of the entire battery bank.

Table 1-4(c) Component Type – Protection System Station dc Supply Using Nickel-Cadmium (NiCad) Batteries Excluding distributed UFLS and distributed UVLS (see Table 3)		
Protection System Station dc supply used only for non-BES interrupting devices for RAS, non-distributed UFLS system, or non-distributed UVLS systems is excluded (see Table 1-4(e)).		
Component Attributes	Maximum Maintenance Interval	Maintenance Activities
Protection System Station dc supply Nickel-Cadmium (NiCad) batteries not having monitoring attributes of Table 1-4(f).	4 Calendar Months	Verify: <ul style="list-style-type: none"> • Station dc supply voltage Inspect: <ul style="list-style-type: none"> • Electrolyte level • For unintentional grounds
	18 Calendar Months	Verify: <ul style="list-style-type: none"> • Float voltage of battery charger • Battery continuity • Battery terminal connection resistance • Battery intercell or unit-to-unit connection resistance Inspect: <ul style="list-style-type: none"> • Cell condition of all individual battery cells. • Physical condition of battery rack

Table 1-4(c) Component Type – Protection System Station dc Supply Using Nickel-Cadmium (NiCad) Batteries Excluding distributed UFLS and distributed UVLS (see Table 3)		
Protection System Station dc supply used only for non-BES interrupting devices for RAS, non-distributed UFLS system, or non-distributed UVLS systems is excluded (see Table 1-4(e)).		
Component Attributes	Maximum Maintenance Interval	Maintenance Activities
	6 Calendar Years	Verify that the station battery can perform as manufactured by conducting a performance or modified performance capacity test of the entire battery bank.

Table 1-4(d) Component Type – Protection System Station dc Supply Using Non Battery Based Energy Storage Excluding distributed UFLS and distributed UVLS (see Table 3)		
Protection System Station dc supply used only for non-BES interrupting devices for RAS, non-distributed UFLS system, or non-distributed UVLS systems is excluded (see Table 1-4(e)).		
Component Attributes	Maximum Maintenance Interval	Maintenance Activities
Any Protection System station dc supply not using a battery and not having monitoring attributes of Table 1-4(f).	4 Calendar Months	Verify: <ul style="list-style-type: none"> • Station dc supply voltage Inspect: <ul style="list-style-type: none"> • For unintentional grounds
	18 Calendar Months	Inspect: Condition of non-battery based dc supply
	6 Calendar Years	Verify that the dc supply can perform as manufactured when ac power is not present.

Table 1-4(e) Component Type – Protection System Station dc Supply for non-BES Interrupting Devices for RAS, non-distributed UFLS, and non-distributed UVLS systems		
Component Attributes	Maximum Maintenance Interval	Maintenance Activities
Any Protection System dc supply used for tripping only non-BES interrupting devices as part of a RAS, non-distributed UFLS, or non-distributed UVLS system and not having monitoring attributes of Table 1-4(f).	When control circuits are verified (See Table 1-5)	Verify Station dc supply voltage.

Table 1-4(f) Exclusions for Protection System Station dc Supply Monitoring Devices and Systems		
Component Attributes	Maximum Maintenance Interval	Maintenance Activities
Any station dc supply with high and low voltage monitoring and alarming of the battery charger voltage to detect charger overvoltage and charger failure (See Table 2).	No periodic maintenance specified	No periodic verification of station dc supply voltage is required.
Any battery based station dc supply with electrolyte level monitoring and alarming in every cell (See Table 2).		No periodic inspection of the electrolyte level for each cell is required.
Any station dc supply with unintentional dc ground monitoring and alarming (See Table 2).		No periodic inspection of unintentional dc grounds is required.
Any station dc supply with charger float voltage monitoring and alarming to ensure correct float voltage is being applied on the station dc supply (See Table 2).		No periodic verification of float voltage of battery charger is required.
Any battery based station dc supply with monitoring and alarming of battery string continuity (See Table 2).		No periodic verification of the battery continuity is required.
Any battery based station dc supply with monitoring and alarming of the intercell and/or terminal connection detail resistance of the entire battery (See Table 2).		No periodic verification of the intercell and terminal connection resistance is required.
Any Valve Regulated Lead-Acid (VRLA) or Vented Lead-Acid (VLA) station battery with internal ohmic value or float current monitoring and alarming, and evaluating present values relative to baseline internal ohmic values for every cell/unit (See Table 2).		No periodic evaluation relative to baseline of battery cell/unit measurements indicative of battery performance is required to verify the station battery can perform as manufactured.
Any Valve Regulated Lead-Acid (VRLA) or Vented Lead-Acid (VLA) station battery with monitoring and alarming of each cell/unit internal ohmic value (See Table 2).		No periodic inspection of the condition of all individual units by measuring battery cell/unit internal ohmic values of a station VRLA or Vented Lead-Acid (VLA) battery is required.

Table 1-5 Component Type - Control Circuitry Associated With Protective Functions Excluding distributed UFLS and distributed UVLS (see Table 3), Automatic Reclosing (see Table 4), and Sudden Pressure Relaying (see Table 5) Note: Table requirements apply to all Control Circuitry Components of Protection Systems, and RAS except as noted.		
Component Attributes	Maximum Maintenance Interval	Maintenance Activities
Trip coils or actuators of circuit breakers, interrupting devices, or mitigating devices (regardless of any monitoring of the control circuitry).	6 Calendar Years	Verify that each trip coil is able to operate the circuit breaker, interrupting device, or mitigating device.
Electromechanical lockout devices which are directly in a trip path from the protective relay to the interrupting device trip coil (regardless of any monitoring of the control circuitry).	6 Calendar Years	Verify electrical operation of electromechanical lockout devices.
Unmonitored control circuitry associated with RAS. (See Table 4-2(b) for RAS which include Automatic Reclosing.)	12 Calendar Years	Verify all paths of the control circuits essential for proper operation of the RAS.
Unmonitored control circuitry associated with protective functions inclusive of all auxiliary relays.	12 Calendar Years	Verify all paths of the trip circuits inclusive of all auxiliary relays through the trip coil(s) of the circuit breakers or other interrupting devices.
Control circuitry associated with protective functions and/or RAS whose integrity is monitored and alarmed (See Table 2).	No periodic maintenance specified	None.

Table 2 – Alarming Paths and Monitoring In Tables 1-1 through 1-5, Table 3, Tables 4-1 through 4-2, and Table 5 alarm attributes used to justify extended maximum maintenance intervals and/or reduced maintenance activities are subject to the following maintenance requirements		
Component Attributes	Maximum Maintenance Interval	Maintenance Activities
Any alarm path through which alarms in Tables 1-1 through 1-5, Table 3, Tables 4-1 through 4-2, and Table 5 are conveyed from the alarm origin to the location where corrective action can be initiated, and not having all the attributes of the “Alarm Path with monitoring” category below. Alarms are reported within 24 hours of detection to a location where corrective action can be initiated.	12 Calendar Years	Verify that the alarm path conveys alarm signals to a location where corrective action can be initiated.
Alarm Path with monitoring: The location where corrective action is taken receives an alarm within 24 hours for failure of any portion of the alarming path from the alarm origin to the location where corrective action can be initiated.	No periodic maintenance specified	None.

Table 3 Maintenance Activities and Intervals for distributed UFLS and distributed UVLS Systems		
Component Attributes	Maximum Maintenance Interval	Maintenance Activities
Any unmonitored protective relay not having all the monitoring attributes of a category below.	6 Calendar Years	<p>Verify that settings are as specified.</p> <p>For non-microprocessor relays:</p> <ul style="list-style-type: none"> • Test and, if necessary calibrate. <p>For microprocessor relays:</p> <ul style="list-style-type: none"> • Verify operation of the relay inputs and outputs that are essential to proper functioning of the Protection System. • Verify acceptable measurement of power system input values.
<p>Monitored microprocessor protective relay with the following:</p> <ul style="list-style-type: none"> • Internal self-diagnosis and alarming (See Table 2). • Voltage and/or current waveform sampling three or more times per power cycle, and conversion of samples to numeric values for measurement calculations by microprocessor electronics. <p>Alarming for power supply failure (See Table 2).</p>	12 Calendar Years	<p>Verify:</p> <ul style="list-style-type: none"> • Settings are as specified. • Operation of the relay inputs and outputs that are essential to proper functioning of the Protection System. • Acceptable measurement of power system input values
<p>Monitored microprocessor protective relay with preceding row attributes and the following:</p> <ul style="list-style-type: none"> • Ac measurements are continuously verified by comparison to an independent ac measurement source, with alarming for excessive error (See Table 2). 	12 Calendar Years	<p>Verify only the unmonitored relay inputs and outputs that are essential to proper functioning of the Protection System.</p>

Table 3 Maintenance Activities and Intervals for distributed UFLS and distributed UVLS Systems		
Component Attributes	Maximum Maintenance Interval	Maintenance Activities
<ul style="list-style-type: none"> Some or all binary or status inputs and control outputs are monitored by a process that continuously demonstrates ability to perform as designed, with alarming for failure (See Table 2). Alarming for change of settings (See Table 2).		
Voltage and/or current sensing devices associated with UFLS or UVLS systems.	12 Calendar Years	Verify that current and/or voltage signal values are provided to the protective relays.
Protection System dc supply for tripping non-BES interrupting devices used only for a UFLS or UVLS system.	12 Calendar Years	Verify Protection System dc supply voltage.
Control circuitry between the UFLS or UVLS relays and electromechanical lockout and/or tripping auxiliary devices (excludes non-BES interrupting device trip coils).	12 Calendar Years	Verify the path from the relay to the lockout and/or tripping auxiliary relay (including essential supervisory logic).
Electromechanical lockout and/or tripping auxiliary devices associated only with UFLS or UVLS systems (excludes non-BES interrupting device trip coils).	12 Calendar Years	Verify electrical operation of electromechanical lockout and/or tripping auxiliary devices.
Control circuitry between the electromechanical lockout and/or tripping auxiliary devices and the non-BES interrupting devices in UFLS or UVLS systems, or between UFLS or UVLS relays (with no interposing electromechanical lockout or auxiliary device) and the non-BES interrupting devices (excludes non-BES interrupting device trip coils).	No periodic maintenance specified	None.
Trip coils of non-BES interrupting devices in UFLS or UVLS systems.	No periodic maintenance specified	None.

Table 4-1 Maintenance Activities and Intervals for Automatic Reclosing Components Component Type – Reclosing Relay		
Component Attributes	Maximum Maintenance Interval	Maintenance Activities
Any unmonitored reclosing relay not having all the monitoring attributes of a category below.	6 Calendar Years	Verify that settings are as specified. For non-microprocessor relays: <ul style="list-style-type: none"> • Test and, if necessary calibrate For microprocessor relays: <ul style="list-style-type: none"> • Verify operation of the relay inputs and outputs that are essential to proper functioning of the Automatic Reclosing.
Monitored microprocessor reclosing relay with the following: <ul style="list-style-type: none"> • Internal self-diagnosis and alarming (See Table 2). • Alarming for power supply failure (See Table 2). 	12 Calendar Years	Verify: <ul style="list-style-type: none"> • Settings are as specified. • Operation of the relay inputs and outputs that are essential to proper functioning of the Automatic Reclosing.

Table 4-2(a) Maintenance Activities and Intervals for Automatic Reclosing Components Component Type – Control Circuitry Associated with Reclosing Relays that are NOT an Integral Part of an RAS		
Component Attributes	Maximum Maintenance Interval	Maintenance Activities
Unmonitored Control circuitry associated with Automatic Reclosing that is not an integral part of an RAS.	12 Calendar Years	Verify that Automatic Reclosing, upon initiation, does not issue a premature closing command to the close circuitry.
Control circuitry associated with Automatic Reclosing that is not part of an RAS and is monitored and alarmed for conditions that would result in a premature closing command. (See Table 2)	No periodic maintenance specified	None.

Table 4-2(b) Maintenance Activities and Intervals for Automatic Reclosing Components Component Type – Control Circuitry Associated with Reclosing Relays that ARE an Integral Part of an RAS		
Component Attributes	Maximum Maintenance Interval	Maintenance Activities
Close coils or actuators of circuit breakers or similar devices that are used in conjunction with Automatic Reclosing as part of an RAS (regardless of any monitoring of the control circuitry).	6 Calendar Years	Verify that each close coil or actuator is able to operate the circuit breaker or mitigating device.
Unmonitored close control circuitry associated with Automatic Reclosing used as an integral part of an RAS.	12 Calendar Years	Verify all paths of the control circuits associated with Automatic Reclosing that are essential for proper operation of the RAS.
Control circuitry associated with Automatic Reclosing that is an integral part of an RAS whose integrity is monitored and alarmed. (See Table 2)	No periodic maintenance specified	None.

Table 5 Maintenance Activities and Intervals for Sudden Pressure Relaying Note: In cases where Components of Sudden Pressure Relaying are common to Components listed in Table 1-5, the Components only need to be tested once during a distinct maintenance interval.		
Component Attributes	Maximum Maintenance Interval	Maintenance Activities
Any fault pressure relay.	6 Calendar Years	Verify the pressure or flow sensing mechanism is operable.
Electromechanical lockout devices which are directly in a trip path from the fault pressure relay to the interrupting device trip coil (regardless of any monitoring of the control circuitry).	6 Calendar Years	Verify electrical operation of electromechanical lockout devices.
Unmonitored control circuitry associated with Sudden Pressure Relaying.	12 Calendar Years	Verify all paths of the trip circuits inclusive of all auxiliary relays through the trip coil(s) of the circuit breakers or other interrupting devices.
Control circuitry associated with Sudden Pressure Relaying whose integrity is monitored and alarmed (See Table 2).	No periodic maintenance specified	None.

Rationale:

During development of this standard, text boxes were embedded within the standard to explain the rationale for various parts of the standard. Upon BOT approval, the text from the rationale text boxes was moved to this section.

Rationale for Applicability Section:

This section does not reflect the applicability changes that will be proposed by the Project 2014-01 Standards Applicability for Dispersed Generation Resources standards drafting team. The changes in this posted version and those being made by the Project 2014-01 standards drafting team do not overlap.

Additionally, to align with ongoing NERC standards development in Project 2010-05.2: Special Protection Systems, the term “Special Protection Systems” in PRC-005-4 was replaced by the term “Remedial Action Schemes.” These terms are synonymous in the NERC Glossary of Terms.

Rationale for the deletion of part of the definition of Component:

The SDT determined that it was explanatory in nature and adequately addressed in the Supplementary Reference and FAQ Document.

Rationale for R3 Part 3.1:

In the last posting, the SDT included language in the standard that was originally in the implementation plan that required completion of maintenance activities within three years for newly-identified Automatic Reclosing Components following a notification under Requirement R6, which has been removed. After further discussion, the SDT determined that a separate shorter timeframe for maintenance of newly-identified Automatic Reclosing Components created unnecessary complication within the standard. The SDT agreed that entities should be responsible for maintaining the Automatic Reclosing Components subject to the standard, whether existing, newly added or newly within scope based on a change in the largest generating unit in the BA or, if a member of a Reserve Sharing Group, the largest generating unit within the Reserve Sharing Group according to the timeframes in the maintenance tables. Therefore, 3.1 and its subparts have been removed and have not been reinserted into the implementation plan.

Rationale for R4 Part 4.1:

In the last posting, the SDT included language in the standard that was originally in the implementation plan that required completion of maintenance activities within three years for newly-identified Automatic Reclosing Components following a notification under Requirement R6, which has been removed. After further discussion, the SDT determined that a separate shorter timeframe for maintenance of newly-identified Automatic Reclosing Components created unnecessary complication within the standard. The SDT agreed that entities should be responsible for maintaining the Automatic Reclosing Components subject to the standard, whether existing, newly added or newly within scope based on a change in the largest generating unit in the BA or, if a member of a Reserve Sharing Group, the largest generating

unit within the Reserve Sharing Group according to the timeframes in the maintenance tables. Therefore, 4.1 and its subparts have been removed and have not been reinserted into the implementation plan.

PRC-005 — Attachment A

Criteria for a Performance-Based Protection System Maintenance Program

Purpose: To establish a technical basis for initial and continued use of a performance-based Protection System Maintenance Program (PSMP).

To establish the technical justification for the initial use of a performance-based PSMP:

1. Develop a list with a description of Components included in each designated Segment, with a minimum Segment population of 60 Components.
2. Maintain the Components in each Segment according to the time-based maximum allowable intervals established in Tables 1-1 through 1-5, Table 3, Tables 4-1 through 4-2, and Table 5 until results of maintenance activities for the Segment are available for a minimum of 30 individual Components of the Segment.
3. Document the maintenance program activities and results for each Segment, including maintenance dates and Countable Events for each included Component.
4. Analyze the maintenance program activities and results for each Segment to determine the overall performance of the Segment and develop maintenance intervals.
5. Determine the maximum allowable maintenance interval for each Segment such that the Segment experiences Countable Events on no more than 4% of the Components within the Segment, for the greater of either the last 30 Components maintained or all Components maintained in the previous year.

To maintain the technical justification for the ongoing use of a performance-based PSMP:

1. At least annually, update the list of Components and Segments and/or description if any changes occur within the Segment.
2. Perform maintenance on the greater of 5% of the Components (addressed in the performance based PSMP) in each Segment or 3 individual Components within the Segment in each year.
3. For the prior year, analyze the maintenance program activities and results for each Segment to determine the overall performance of the Segment.
4. Using the prior year's data, determine the maximum allowable maintenance interval for each Segment such that the Segment experiences Countable Events on no more than 4% of the Components within the Segment, for the greater of either the last 30 Components maintained or all Components maintained in the previous year.

If the Components in a Segment maintained through a performance-based PSMP experience 4% or more Countable Events, develop, document, and implement an action plan to reduce the Countable Events to less than 4% of the Segment population within 3 years.

Standard Development Timeline

This section is maintained by the drafting team during the development of the standard and will be removed when the standard becomes effective.

Development Steps Completed

1. SAR posted for comment November 20, 2013 – December 19, 2013.
2. An earlier draft of this standard was posted for a 45-day comment and ballot period June 12, 2014–July 29, 2014.
3. PRC-005-3(X) passed a final ballot, which was posted for a 10-day ballot period of August 27, 2014-September 5, 2014.
4. PRC-005-5 passed an initial ballot, which was posted for a 45-day Formal Comment Period with Parallel Ballot December 8, 2014 – January 22, 2015.

Description of Current Draft

The Dispersed Generation Resources Standard Drafting Team (DGR SDT) is posting this version of PRC-005 for final ballot under the new Standards Process Manual (Effective: June 26, 2013). This version includes all substantive changes recently approved by the NERC Board of Trustees in addition to applicability changes recommended by the DGR SDT.

<u>Anticipated Actions</u>	<u>Anticipated Dates</u>
<u>45-day Formal Comment Period with Parallel Ballot</u>	<u>December 8, 2014 – January 22, 2015</u>
<u>Final ballot</u>	<u>March 2015</u>
<u>BOT adoption</u>	<u>May 2015</u>

Definitions of Terms Used in Standard

This section includes all newly defined or revised terms used in the proposed standard. Terms already defined in the Reliability Standards Glossary of Terms (Glossary) are not repeated here. New or revised definitions listed below become approved when the proposed standard is approved. When the standard becomes effective, this defined term will be removed from the individual standard and added to the Glossary.

None.

A. Introduction

1. **Title:** Protection System, Automatic Reclosing, and Sudden Pressure Relaying Maintenance
2. **Number:** PRC-005-54
3. **Purpose:** To document and implement programs for the maintenance of all Protection Systems, Automatic Reclosing, and Sudden Pressure Relaying affecting the reliability of the Bulk Electric System (BES) so that they are kept in working order.
4. **Applicability:**
 - 4.1. **Functional Entities:**
 - 4.1.1 Transmission Owner
 - 4.1.2 Generator Owner
 - 4.1.3 Distribution Provider
 - 4.2. **Facilities:**
 - 4.2.1 Protection Systems and Sudden Pressure Relaying that are installed for the purpose of detecting Faults on BES Elements (lines, buses, transformers, etc.)
 - 4.2.2 Protection Systems used for underfrequency load-shedding systems installed per ERO underfrequency load-shedding requirements.
 - 4.2.3 Protection Systems used for undervoltage load-shedding systems installed to prevent system voltage collapse or voltage instability for BES reliability.
 - 4.2.4 Protection Systems installed as a Remedial Action Scheme (RAS) for BES reliability.
 - 4.2.5 Protection Systems and Sudden Pressure Relaying for generator Facilities that are part of the BES, except for generators identified through Inclusion I4 of the BES definition, including:
 - 4.2.5.1 Protection Systems that act to trip the generator either directly or via lockout or auxiliary tripping relays.
 - 4.2.5.2 Protection Systems and Sudden Pressure Relaying for generator step-up transformers for generators that are part of the BES.

Rationale for section 4.2.5: These applicability revisions are intended to clarify and provide for consistent application of the Requirements to BES generator Facilities included in the BES through Inclusion I4 – Dispersed Power Producing Resources. The SDT modified the language for clarity based on comments received and is not changing the intent of the standard modification from the last posted version of this standard.

~~4.2.5.3~~ ~~Protection Systems and Sudden Pressure Relaying for transformers connecting aggregated generation, where the aggregated generation is part of the BES (e.g., transformers connecting facilities such as wind farms to the BES).~~

4.2.5.3 Protection Systems and Sudden Pressure Relaying for station service or excitation transformers connected to the generator bus of generators which are part of the BES, that act to trip the generator either directly or via lockout or tripping auxiliary relays.

4.2.6 Protection Systems and Sudden Pressure Relaying for the following BES generator Facilities for dispersed power producing resources identified through Inclusion I4 of the BES definition:

~~4.2.5.44.2.6.1~~ 4.2.6.14.2.6.1 Protection Systems and Sudden Pressure Relaying for Facilities used in aggregating dispersed BES generation from the point where those resources aggregate to greater than 75 MVA to a common point of connection at 100kV or above.

4.2.6.4.2.7 Automatic Reclosing¹, including:

~~4.2.6.14.2.7.1~~ 4.2.6.14.2.7.1 Automatic Reclosing applied on the terminals of Elements connected to the BES bus located at generating plant substations where the total installed gross generating plant capacity is greater than the gross capacity of the largest BES generating unit within the Balancing Authority Area or, if a member of a Reserve Sharing Group, the largest generating unit within the Reserve Sharing Group.²

~~4.2.6.24.2.7.2~~ 4.2.6.24.2.7.2 Automatic Reclosing applied on the terminals of all BES Elements at substations one bus away from generating plants specified in Section 4.2.76.1 when the substation is less than 10 circuit-miles from the generating plant substation.

~~4.2.6.34.2.7.3~~ 4.2.6.34.2.7.3 Automatic Reclosing applied as an integral part of an RAS specified in Section 4.2.4.

¹ Automatic Reclosing addressed in Section 4.2.76.1 and 4.2.76.2 may be excluded if the equipment owner can demonstrate that a close-in three-phase fault present for twice the normal clearing time (capturing a minimum trip-close-trip time delay) does not result in a total loss of gross generation in the Interconnection exceeding the gross capacity of the largest relevant BES generating unit where the Automatic Reclosing is applied.

² The largest BES generating unit within the Balancing Authority Area or the largest generating unit within the Reserve Sharing Group, as applicable, is subject to change. As a result of such a change, the Automatic Reclosing Components subject to the standard could change effective on the date of such change.

5. **Effective Date:** See [the Implementation Plan for this standard.](#)

6. **Definitions Used in this Standard:**

Automatic Reclosing – Includes the following Components:

- Reclosing relay
- Control circuitry associated with the reclosing relay.

Sudden Pressure Relaying – A system that trips an interrupting device(s) to isolate the equipment it is monitoring and includes the following Components:

- Fault pressure relay – a mechanical relay or device that detects rapid changes in gas pressure, oil pressure, or oil flow that are indicative of Faults within liquid-filled, wire-wound equipment
- Control circuitry associated with a fault pressure relay

Unresolved Maintenance Issue – A deficiency identified during a maintenance activity that causes the Component to not meet the intended performance, cannot be corrected during the maintenance interval, and requires follow-up corrective action.

Segment – Components of a consistent design standard, or a particular model or type from a single manufacturer that typically share other common elements. Consistent performance is expected across the entire population of a Segment. A Segment must contain at least sixty (60) individual Components.

Component Type –

- Any one of the five specific elements of a Protection System.
- Any one of the two specific elements of Automatic Reclosing.
- Any one of the two specific elements of Sudden Pressure Relaying.

Component – Any individual discrete piece of equipment included in a Protection System, Automatic Reclosing, or Sudden Pressure Relaying.

Countable Event – A failure of a Component requiring repair or replacement, any condition discovered during the maintenance activities in Tables 1-1 through 1-5, Table 3, Tables 4-1 through 4-2, and Table 5, which requires corrective action or a Protection System Misoperation attributed to hardware failure or calibration failure. Misoperations due to product design errors, software errors, relay settings different from specified settings, Protection System Component, Automatic Reclosing, or Sudden Pressure Relaying configuration or application errors are not included in Countable Events.

B. Requirements and Measures

- R1.** Each Transmission Owner, Generator Owner, and Distribution Provider shall establish a Protection System Maintenance Program (PSMP) for its Protection Systems, Automatic Reclosing, and Sudden Pressure Relaying identified in Section 4.2, Facilities. *[Violation Risk Factor: Medium] [Time Horizon: Operations Planning]*

The PSMP shall:

- 1.1.** Identify which maintenance method (time-based, performance-based per PRC-005 Attachment A, or a combination) is used to address each Protection System, Automatic Reclosing, and Sudden Pressure Relaying Component Type. All batteries associated with the station dc supply Component Type of a Protection System shall be included in a time-based program as described in Table 1-4 and Table 3.
 - 1.2.** Include the applicable monitored Component attributes applied to each Protection System, Automatic Reclosing, and Sudden Pressure Relaying Component Type consistent with the maintenance intervals specified in Tables 1-1 through 1-5, Table 2, Table 3, Table 4-1 through 4-2, and Table 5 where monitoring is used to extend the maintenance intervals beyond those specified for unmonitored Protection System, Automatic Reclosing, and Sudden Pressure Relaying Components.
- M1.** Each Transmission Owner, Generator Owner and Distribution Provider shall have a documented Protection System Maintenance Program in accordance with Requirement R1.
- For each Protection System, Automatic Reclosing, and Sudden Pressure Relaying Component Type, the documentation shall include the type of maintenance method applied (time-based, performance-based, or a combination of these maintenance methods), and shall include all batteries associated with the station dc supply Component Types in a time-based program as described in Table 1-4 and Table 3. (Part 1.1)
- For Component Types that use monitoring to extend the maintenance intervals, the responsible entity(s) shall have evidence for each Protection System, Automatic Reclosing, and Sudden Pressure Relaying Component Type (such as manufacturer's specifications or engineering drawings) of the appropriate monitored Component attributes as specified in Tables 1-1 through 1-5, Table 2, Table 3, Table 4-1 through 4-2, and Table 5. (Part 1.2)
- R2.** Each Transmission Owner, Generator Owner, and Distribution Provider that uses performance-based maintenance intervals in its PSMP shall follow the procedure established in PRC-005 Attachment A to establish and maintain its performance-based intervals. *[Violation Risk Factor: Medium] [Time Horizon: Operations Planning]*
- M2.** Each Transmission Owner, Generator Owner, and Distribution Provider that uses performance-based maintenance intervals shall have evidence that its current performance-based maintenance program(s) is in accordance with Requirement R2,

which may include, but is not limited to, Component lists, dated maintenance records, and dated analysis records and results.

- R3.** Each Transmission Owner, Generator Owner, and Distribution Provider that utilizes time-based maintenance program(s) shall maintain its Protection System, Automatic Reclosing, and Sudden Pressure Relaying Components that are included within the time-based maintenance program in accordance with the minimum maintenance activities and maximum maintenance intervals prescribed within Tables 1-1 through 1-5, Table 2, Table 3, Table 4-1 through 4-2, and Table 5. *[Violation Risk Factor: High]*
[Time Horizon: Operations Planning]
- M3.** Each Transmission Owner, Generator Owner, and Distribution Provider that utilizes time-based maintenance program(s) shall have evidence that it has maintained its Protection System, Automatic Reclosing, and Sudden Pressure Relaying Components included within its time-based program in accordance with Requirement R3. The evidence may include, but is not limited to, dated maintenance records, dated maintenance summaries, dated check-off lists, dated inspection records, or dated work orders.
- R4.** Each Transmission Owner, Generator Owner, and Distribution Provider that utilizes performance-based maintenance program(s) in accordance with Requirement R2 shall implement and follow its PSMP for its Protection System, Automatic Reclosing, and Sudden Pressure Relaying Components that are included within the performance-based program(s). *[Violation Risk Factor: High]* *[Time Horizon: Operations Planning]*
- M4.** Each Transmission Owner, Generator Owner, and Distribution Provider that utilizes performance-based maintenance intervals in accordance with Requirement R2 shall have evidence that it has implemented the Protection System Maintenance Program for the Protection System, Automatic Reclosing, and Sudden Pressure Relaying Components included in its performance-based program in accordance with Requirement R4. The evidence may include, but is not limited to, dated maintenance records, dated maintenance summaries, dated check-off lists, dated inspection records, or dated work orders.
- R5.** Each Transmission Owner, Generator Owner, and Distribution Provider shall demonstrate efforts to correct identified Unresolved Maintenance Issues. *[Violation Risk Factor: Medium]* *[Time Horizon: Operations Planning]*
- M5.** Each Transmission Owner, Generator Owner, and Distribution Provider shall have evidence that it has undertaken efforts to correct identified Unresolved Maintenance Issues in accordance with Requirement R5. The evidence may include, but is not limited to, work orders, replacement Component orders, invoices, project schedules with completed milestones, return material authorizations (RMAs) or purchase orders.

C. Compliance

1. Compliance Monitoring Process

1.1. Compliance Enforcement Authority

As defined in the NERC Rules of Procedure, “Compliance Enforcement Authority” means NERC or the Regional Entity in their respective roles of monitoring and enforcing compliance with the NERC Reliability Standards.

1.2. Evidence Retention

The following evidence retention periods identify the period of time an entity is required to retain specific evidence to demonstrate compliance. For instances where the evidence retention period specified below is shorter than the time since the last audit, the Compliance Enforcement Authority may ask an entity to provide other evidence to show that it was compliant for the full time period since the last audit.

The Transmission Owner, Generator Owner, and Distribution Provider shall each keep data or evidence to show compliance as identified below unless directed by its Compliance Enforcement Authority to retain specific evidence for a longer period of time as part of an investigation.

For Requirement R1, the Transmission Owner, Generator Owner, and Distribution Provider shall each keep its current dated Protection System Maintenance Program, as well as any superseded versions since the preceding compliance audit, including the documentation that specifies the type of maintenance program applied for each Protection System, Automatic Reclosing, or Sudden Pressure Relaying Component Type.

For Requirement R2, Requirement R3, and Requirement R4, in cases where the interval of the maintenance activity is longer than the audit cycle, the Transmission Owner, Generator Owner, and Distribution Provider shall each keep documentation of the most recent performance of that maintenance activity for the Protection System, Automatic Reclosing, or Sudden Pressure Relaying Component. In cases where the interval of the maintenance activity is shorter than the audit cycle, documentation of all performances (in accordance with the tables) of that maintenance activity for the Protection System, Automatic Reclosing, or Sudden Pressure Relaying Component since the previous scheduled audit date shall be retained.

For Requirement R5 the Transmission Owner, Generator Owner, and Distribution Provider shall each keep documentation of Unresolved Maintenance Issues identified by the entity since the last audit, including all that were resolved since the last audit.

The Compliance Enforcement Authority shall keep the last audit records and all requested and submitted subsequent audit records.

1.3. Compliance Monitoring and Assessment Processes:

Compliance Audits

Self-Certifications

Spot Checking

Compliance Violation Investigations

Self-Reporting

Complaints

1.4. Additional Compliance Information

None

Table of Compliance Elements

Requirement Number	Lower VSL	Moderate VSL	High VSL	Severe VSL
R1	The entity’s PSMP failed to specify whether one Component Type is being addressed by time-based or performance-based maintenance, or a combination of both (Part 1.1).	The entity’s PSMP failed to specify whether two Component Types are being addressed by time-based or performance-based maintenance, or a combination of both (Part 1.1).	The entity’s PSMP failed to specify whether three Component Types are being addressed by time-based or performance-based maintenance, or a combination of both. (Part 1.1). OR The entity’s PSMP failed to include the applicable monitoring attributes applied to each Component Type consistent with the maintenance intervals specified in Tables 1-1 through 1-5, Table 2, Table 3, Tables 4-1 through 4-2, and Table 5 where monitoring is used to extend the maintenance intervals beyond those specified for unmonitored Components (Part 1.2).	The entity failed to establish a PSMP. OR The entity’s PSMP failed to specify whether four or more Component Types are being addressed by time-based or performance-based maintenance, or a combination of both (Part 1.1). OR The entity’s PSMP failed to include applicable station batteries in a time-based program (Part 1.1).
R2	The entity uses performance-based maintenance intervals in its PSMP but failed to reduce Countable Events to no more than 4% within three years.	NA	The entity uses performance-based maintenance intervals in its PSMP but failed to reduce Countable Events to no more than 4% within four years.	The entity uses performance-based maintenance intervals in its PSMP but: 1) Failed to establish the technical justification described within Requirement R2 for the initial use of the performance-based PSMP OR 2) Failed to reduce Countable Events to no more than 4% within five years OR

Requirement Number	Lower VSL	Moderate VSL	High VSL	Severe VSL
				3) Maintained a Segment with less than 60 Components OR 4) Failed to: <ul style="list-style-type: none"> • Annually update the list of Components, OR • Annually perform maintenance on the greater of 5% of the Segment population or 3 Components, OR • Annually analyze the program activities and results for each Segment.
R3	For Components included within a time-based maintenance program, the entity failed to maintain 5% or less of the total Components included within a specific Component Type in accordance with the minimum maintenance activities and maximum maintenance intervals prescribed within Tables 1-1 through 1-5, Table 2, Table 3, Tables 4-1 through 4-2, and Table 5.	For Components included within a time-based maintenance program, the entity failed to maintain more than 5% but 10% or less of the total Components included within a specific Component Type in accordance with the minimum maintenance activities and maximum maintenance intervals prescribed within Tables 1-1 through 1-5, Table 2, Table 3, Tables 4-1 through 4-2, and Table 5.	For Components included within a time-based maintenance program, the entity failed to maintain more than 10% but 15% or less of the total Components included within a specific Component Type in accordance with the minimum maintenance activities and maximum maintenance intervals prescribed within Tables 1-1 through 1-5, Table 2, Table 3, Tables 4-1 through 4-2, and Table 5.	For Components included within a time-based maintenance program, the entity failed to maintain more than 15% of the total Components included within a specific Component Type in accordance with the minimum maintenance activities and maximum maintenance intervals prescribed within Tables 1-1 through 1-5, Table 2, Table 3, Tables 4-1 through 4-2, and Table 5.

Requirement Number	Lower VSL	Moderate VSL	High VSL	Severe VSL
R4	For Components included within a performance-based maintenance program, the entity failed to maintain 5% or less of the annual scheduled maintenance for a specific Component Type in accordance with their performance-based PSMP.	For Components included within a performance-based maintenance program, the entity failed to maintain more than 5% but 10% or less of the annual scheduled maintenance for a specific Component Type in accordance with their performance-based PSMP.	For Components included within a performance-based maintenance program, the entity failed to maintain more than 10% but 15% or less of the annual scheduled maintenance for a specific Component Type in accordance with their performance-based PSMP.	For Components included within a performance-based maintenance program, the entity failed to maintain more than 15% of the annual scheduled maintenance for a specific Component Type in accordance with their performance-based PSMP.
R5	The entity failed to undertake efforts to correct 5 or fewer identified Unresolved Maintenance Issues.	The entity failed to undertake efforts to correct greater than 5 but less than or equal to 10 identified Unresolved Maintenance Issues.	The entity failed to undertake efforts to correct greater than 10 but less than or equal to 15 identified Unresolved Maintenance Issues.	The entity failed to undertake efforts to correct greater than 15 identified Unresolved Maintenance Issues.

D. Regional Variances

None.

E. Interpretations

None.

Supplemental Reference Documents

The following documents present a detailed discussion about determination of maintenance intervals and other useful information regarding establishment of a maintenance program.

1. *Supplementary Reference and FAQ - PRC-005-4 Protection System Maintenance*, Protection System Maintenance and Testing Standard Drafting Team (April 2014)
2. *Considerations for Maintenance and Testing of Auto-reclosing Schemes*, NERC System Analysis and Modeling Subcommittee, and NERC System Protection and Control Subcommittee (November 2012)
3. *Sudden Pressure Relays and Other Devices that Respond to Non-Electrical Quantities – SPCS Input for Standard Development in Response to FERC Order No. 758*, NERC System Protection and Control Subcommittee (December 2013)
4. *Sudden Pressure Relays and Other Devices that Respond to Non-Electrical Quantities – Supplemental Information to Support Project 2007-17.3: Protection System Maintenance and Testing* (October 31, 2014)

Version History

Version	Date	Action	Change Tracking
0	February 8, 2005	Adopted by NERC Board of Trustees	New
1	February 7, 2006	Adopted by NERC Board of Trustees	<ol style="list-style-type: none"> 1. Changed incorrect use of certain hyphens (-) to “en dash” (–) and “em dash (—).” 2. Added “periods” to items where appropriate. Changed “Timeframe” to “Time Frame” in item D, 1.2.
1a	February 17, 2011	Adopted by NERC Board of Trustees	Added Appendix 1 - Interpretation regarding applicability of standard to protection of radially connected transformers developed in Project 2009-17

Version	Date	Action	Change Tracking
1b	November 5, 2009	Adopted by NERC Board of Trustees	Interpretation of R1, R1.1, and R1.2 developed by Project 2009-10
1b	February 3, 2012	FERC Order approving revised definition of “Protection System”	Per footnote 8 of FERC’s order, the definition of “Protection System” supersedes interpretation “b” of PRC-005-1b upon the effective date of the modified definition (i.e., April 1, 2013) <i>See N. Amer. Elec. Reliability Corp., 138 FERC ¶ 61,095 (February 3, 2012).</i>
1.1b	May 9, 2012	Adopted by NERC Board of Trustees	Errata change developed by Project 2010-07, clarified inclusion of generator interconnection Facility in Generator Owner’s responsibility
2	November 7, 2012	Adopted by NERC Board of Trustees	Project 2007-17 - Complete revision, absorbing maintenance requirements from PRC-005-1.1b, PRC-008-0, PRC-011-0, PRC-017-0
2	October 17, 2013	Approved by NERC Standards Committee	Errata Change: The Standards Committee approved an errata change to the implementation plan for PRC-005-2 to add the phrase “or as otherwise made effective pursuant to the laws applicable to such ERO governmental authorities;” to the second sentence under the “Retirement of Existing Standards” section. (no change to standard version number)
2	March 7, 2014	Adopted by NERC Board of Trustees	Modified R1 VSL in response to FERC directive (no change to standard version number)
2(i)	November 13, 2014	Adopted by NERC Board of Trustees	Applicability section revised by Project 2014-01 to clarify application of Requirements to BES dispersed power producing resources

Version	Date	Action	Change Tracking
2(ii)	November 13, 2014	Adopted by NERC Board of Trustees	Replaced references to Special Protection System and SPS with Remedial Action Scheme and RAS
3	November 7, 2013	Adopted by the NERC Board of Trustees	Revised to address the FERC directive in Order No. 758 to include Automatic Reclosing in maintenance programs
3	February 12, 2014	Approved by NERC Standards Committee	Errata Change: The Standards Committee approved errata changes to correct capitalization of certain defined terms within the definitions of “Unresolved Maintenance Issue” and “Protection System Maintenance Program”. The changes will be reflected in the definitions section of PRC-005-3 for “Unresolved Maintenance Issue” and in the NERC Glossary of Terms for “Protection System Maintenance Program”. (no change to standard version number)
3	March 7, 2014	Adopted by NERC Board of Trustees	Modified R1 VSL in response to FERC directive (no change to standard version number)
3(i)	November 13, 2014	Adopted by NERC Board of Trustees	Applicability section revised by Project 2014-01 to clarify application of Requirements to BES dispersed power producing resources
3(ii)	November 13, 2014	Adopted by NERC Board of Trustees	Replaced references to Special Protection System and SPS with Remedial Action Scheme and RAS
4	November 13, 2014	Adopted by NERC Board of Trustees	Added Sudden Pressure Relaying in response to FERC Order No. 758

Version	Date	Action	Change Tracking
<u>5</u>	<u>TBD</u>		<u>Applicability section revised by Project 2014-01 to clarify application of Requirements to BES dispersed power producing resources</u>

Table 1-1 Component Type - Protective Relay Excluding distributed UFLS and distributed UVLS (see Table 3)		
Component Attributes	Maximum Maintenance Interval ³	Maintenance Activities
Any unmonitored protective relay not having all the monitoring attributes of a category below.	6 Calendar Years	For all unmonitored relays: <ul style="list-style-type: none"> • Verify that settings are as specified For non-microprocessor relays: <ul style="list-style-type: none"> • Test and, if necessary calibrate For microprocessor relays: <ul style="list-style-type: none"> • Verify operation of the relay inputs and outputs that are essential to proper functioning of the Protection System. • Verify acceptable measurement of power system input values.
Monitored microprocessor protective relay with the following: <ul style="list-style-type: none"> • Internal self-diagnosis and alarming (see Table 2). • Voltage and/or current waveform sampling three or more times per power cycle, and conversion of samples to numeric values for measurement calculations by microprocessor electronics. • Alarming for power supply failure (see Table 2). 	12 Calendar Years	Verify: <ul style="list-style-type: none"> • Settings are as specified. • Operation of the relay inputs and outputs that are essential to proper functioning of the Protection System. • Acceptable measurement of power system input values.

³ For the tables in this standard, a calendar year starts on the first day of a new year (January 1) after a maintenance activity has been completed. For the tables in this standard, a calendar month starts on the first day of the first month after a maintenance activity has been completed.

Table 1-1 Component Type - Protective Relay Excluding distributed UFLS and distributed UVLS (see Table 3)		
Component Attributes	Maximum Maintenance Interval ³	Maintenance Activities
Monitored microprocessor protective relay with preceding row attributes and the following: <ul style="list-style-type: none"> • Ac measurements are continuously verified by comparison to an independent ac measurement source, with alarming for excessive error (See Table 2). • Some or all binary or status inputs and control outputs are monitored by a process that continuously demonstrates ability to perform as designed, with alarming for failure (See Table 2). • Alarming for change of settings (See Table 2). 	12 Calendar Years	Verify only the unmonitored relay inputs and outputs that are essential to proper functioning of the Protection System.

Table 1-2 Component Type - Communications Systems Excluding distributed UFLS and distributed UVLS (see Table 3)		
Component Attributes	Maximum Maintenance Interval	Maintenance Activities
Any unmonitored communications system necessary for correct operation of protective functions, and not having all the monitoring attributes of a category below.	4 Calendar Months	Verify that the communications system is functional.
	6 Calendar Years	Verify that the communications system meets performance criteria pertinent to the communications technology applied (e.g. signal level, reflected power, or data error rate). Verify operation of communications system inputs and outputs that are essential to proper functioning of the Protection System.
Any communications system with continuous monitoring or periodic automated testing for the presence of the channel function, and alarming for loss of function (See Table 2).	12 Calendar Years	Verify that the communications system meets performance criteria pertinent to the communications technology applied (e.g. signal level, reflected power, or data error rate). Verify operation of communications system inputs and outputs that are essential to proper functioning of the Protection System.
Any communications system with all of the following: <ul style="list-style-type: none"> • Continuous monitoring or periodic automated testing for the performance of the channel using criteria pertinent to the communications technology applied (e.g. signal level, reflected power, or data error rate, and alarming for excessive performance degradation). (See Table 2) • Some or all binary or status inputs and control outputs are monitored by a process that continuously demonstrates ability to perform as designed, with alarming for failure (See Table 2). 	12 Calendar Years	Verify only the unmonitored communications system inputs and outputs that are essential to proper functioning of the Protection System

Table 1-3 Component Type - Voltage and Current Sensing Devices Providing Inputs to Protective Relays Excluding distributed UFLS and distributed UVLS (see Table 3)		
Component Attributes	Maximum Maintenance Interval	Maintenance Activities
Any voltage and current sensing devices not having monitoring attributes of the category below.	12 Calendar Years	Verify that current and voltage signal values are provided to the protective relays.
Voltage and Current Sensing devices connected to microprocessor relays with AC measurements are continuously verified by comparison of sensing input value, as measured by the microprocessor relay, to an independent ac measurement source, with alarming for unacceptable error or failure (see Table 2).	No periodic maintenance specified	None.

Table 1-4(a) Component Type – Protection System Station dc Supply Using Vented Lead-Acid (VLA) Batteries Excluding distributed UFLS and distributed UVLS (see Table 3)		
Protection System Station dc supply used only for non-BES interrupting devices for RAS, non-distributed UFLS systems, or non-distributed UVLS systems is excluded (see Table 1-4(e)).		
Component Attributes	Maximum Maintenance Interval	Maintenance Activities
Protection System Station dc supply using Vented Lead-Acid (VLA) batteries not having monitoring attributes of Table 1-4(f).	4 Calendar Months	Verify: <ul style="list-style-type: none"> • Station dc supply voltage Inspect: <ul style="list-style-type: none"> • Electrolyte level • For unintentional grounds
	18 Calendar Months	Verify: <ul style="list-style-type: none"> • Float voltage of battery charger • Battery continuity • Battery terminal connection resistance • Battery intercell or unit-to-unit connection resistance Inspect: <ul style="list-style-type: none"> • Cell condition of all individual battery cells where cells are visible – or measure battery cell/unit internal ohmic values where the cells are not visible • Physical condition of battery rack

Table 1-4(a) Component Type – Protection System Station dc Supply Using Vented Lead-Acid (VLA) Batteries Excluding distributed UFLS and distributed UVLS (see Table 3)		
Protection System Station dc supply used only for non-BES interrupting devices for RAS, non-distributed UFLS systems, or non-distributed UVLS systems is excluded (see Table 1-4(e)).		
Component Attributes	Maximum Maintenance Interval	Maintenance Activities
	18 Calendar Months -or- 6 Calendar Years	Verify that the station battery can perform as manufactured by evaluating cell/unit measurements indicative of battery performance (e.g. internal ohmic values or float current) against the station battery baseline. -or- Verify that the station battery can perform as manufactured by conducting a performance or modified performance capacity test of the entire battery bank.

Table 1-4(b) Component Type – Protection System Station dc Supply Using Valve-Regulated Lead-Acid (VRLA) Batteries Excluding distributed UFLS and distributed UVLS (see Table 3)		
Protection System Station dc supply used only for non-BES interrupting devices for RAS, non-distributed UFLS systems, or non-distributed UVLS systems is excluded (see Table 1-4(e)).		
Component Attributes	Maximum Maintenance Interval	Maintenance Activities
Protection System Station dc supply with Valve Regulated Lead-Acid (VRLA) batteries not having monitoring attributes of Table 1-4(f).	4 Calendar Months	Verify: <ul style="list-style-type: none"> • Station dc supply voltage Inspect: <ul style="list-style-type: none"> • For unintentional grounds
	6 Calendar Months	Inspect: <ul style="list-style-type: none"> • Condition of all individual units by measuring battery cell/unit internal ohmic values.
	18 Calendar Months	Verify: <ul style="list-style-type: none"> • Float voltage of battery charger • Battery continuity • Battery terminal connection resistance • Battery intercell or unit-to-unit connection resistance Inspect: <ul style="list-style-type: none"> • Physical condition of battery rack

Table 1-4(b) Component Type – Protection System Station dc Supply Using Valve-Regulated Lead-Acid (VRLA) Batteries Excluding distributed UFLS and distributed UVLS (see Table 3)		
Protection System Station dc supply used only for non-BES interrupting devices for RAS, non-distributed UFLS systems, or non-distributed UVLS systems is excluded (see Table 1-4(e)).		
Component Attributes	Maximum Maintenance Interval	Maintenance Activities
	6 Calendar Months -or- 3 Calendar Years	Verify that the station battery can perform as manufactured by evaluating cell/unit measurements indicative of battery performance (e.g. internal ohmic values or float current) against the station battery baseline. -or- Verify that the station battery can perform as manufactured by conducting a performance or modified performance capacity test of the entire battery bank.

Table 1-4(c) Component Type – Protection System Station dc Supply Using Nickel-Cadmium (NiCad) Batteries Excluding distributed UFLS and distributed UVLS (see Table 3)		
Protection System Station dc supply used only for non-BES interrupting devices for RAS, non-distributed UFLS system, or non-distributed UVLS systems is excluded (see Table 1-4(e)).		
Component Attributes	Maximum Maintenance Interval	Maintenance Activities
Protection System Station dc supply Nickel-Cadmium (NiCad) batteries not having monitoring attributes of Table 1-4(f).	4 Calendar Months	Verify: <ul style="list-style-type: none"> • Station dc supply voltage Inspect: <ul style="list-style-type: none"> • Electrolyte level • For unintentional grounds
	18 Calendar Months	Verify: <ul style="list-style-type: none"> • Float voltage of battery charger • Battery continuity • Battery terminal connection resistance • Battery intercell or unit-to-unit connection resistance Inspect: <ul style="list-style-type: none"> • Cell condition of all individual battery cells. • Physical condition of battery rack

Table 1-4(c) Component Type – Protection System Station dc Supply Using Nickel-Cadmium (NiCad) Batteries Excluding distributed UFLS and distributed UVLS (see Table 3)		
Protection System Station dc supply used only for non-BES interrupting devices for RAS, non-distributed UFLS system, or non-distributed UVLS systems is excluded (see Table 1-4(e)).		
Component Attributes	Maximum Maintenance Interval	Maintenance Activities
	6 Calendar Years	Verify that the station battery can perform as manufactured by conducting a performance or modified performance capacity test of the entire battery bank.

Table 1-4(d) Component Type – Protection System Station dc Supply Using Non Battery Based Energy Storage Excluding distributed UFLS and distributed UVLS (see Table 3) Protection System Station dc supply used only for non-BES interrupting devices for RAS, non-distributed UFLS system, or non-distributed UVLS systems is excluded (see Table 1-4(e)).		
Component Attributes	Maximum Maintenance Interval	Maintenance Activities
Any Protection System station dc supply not using a battery and not having monitoring attributes of Table 1-4(f).	4 Calendar Months	Verify: <ul style="list-style-type: none"> • Station dc supply voltage Inspect: <ul style="list-style-type: none"> • For unintentional grounds
	18 Calendar Months	Inspect: Condition of non-battery based dc supply
	6 Calendar Years	Verify that the dc supply can perform as manufactured when ac power is not present.

Table 1-4(e) Component Type – Protection System Station dc Supply for non-BES Interrupting Devices for RAS, non-distributed UFLS, and non-distributed UVLS systems		
Component Attributes	Maximum Maintenance Interval	Maintenance Activities
Any Protection System dc supply used for tripping only non-BES interrupting devices as part of a RAS, non-distributed UFLS, or non-distributed UVLS system and not having monitoring attributes of Table 1-4(f).	When control circuits are verified (See Table 1-5)	Verify Station dc supply voltage.

Table 1-4(f) Exclusions for Protection System Station dc Supply Monitoring Devices and Systems		
Component Attributes	Maximum Maintenance Interval	Maintenance Activities
Any station dc supply with high and low voltage monitoring and alarming of the battery charger voltage to detect charger overvoltage and charger failure (See Table 2).	No periodic maintenance specified	No periodic verification of station dc supply voltage is required.
Any battery based station dc supply with electrolyte level monitoring and alarming in every cell (See Table 2).		No periodic inspection of the electrolyte level for each cell is required.
Any station dc supply with unintentional dc ground monitoring and alarming (See Table 2).		No periodic inspection of unintentional dc grounds is required.
Any station dc supply with charger float voltage monitoring and alarming to ensure correct float voltage is being applied on the station dc supply (See Table 2).		No periodic verification of float voltage of battery charger is required.
Any battery based station dc supply with monitoring and alarming of battery string continuity (See Table 2).		No periodic verification of the battery continuity is required.
Any battery based station dc supply with monitoring and alarming of the intercell and/or terminal connection detail resistance of the entire battery (See Table 2).		No periodic verification of the intercell and terminal connection resistance is required.
Any Valve Regulated Lead-Acid (VRLA) or Vented Lead-Acid (VLA) station battery with internal ohmic value or float current monitoring and alarming, and evaluating present values relative to baseline internal ohmic values for every cell/unit (See Table 2).		No periodic evaluation relative to baseline of battery cell/unit measurements indicative of battery performance is required to verify the station battery can perform as manufactured.
Any Valve Regulated Lead-Acid (VRLA) or Vented Lead-Acid (VLA) station battery with monitoring and alarming of each cell/unit internal ohmic value (See Table 2).		No periodic inspection of the condition of all individual units by measuring battery cell/unit internal ohmic values of a station VRLA or Vented Lead-Acid (VLA) battery is required.

Table 1-5 Component Type - Control Circuitry Associated With Protective Functions Excluding distributed UFLS and distributed UVLS (see Table 3), Automatic Reclosing (see Table 4), and Sudden Pressure Relaying (see Table 5) Note: Table requirements apply to all Control Circuitry Components of Protection Systems, and RAS except as noted.		
Component Attributes	Maximum Maintenance Interval	Maintenance Activities
Trip coils or actuators of circuit breakers, interrupting devices, or mitigating devices (regardless of any monitoring of the control circuitry).	6 Calendar Years	Verify that each trip coil is able to operate the circuit breaker, interrupting device, or mitigating device.
Electromechanical lockout devices which are directly in a trip path from the protective relay to the interrupting device trip coil (regardless of any monitoring of the control circuitry).	6 Calendar Years	Verify electrical operation of electromechanical lockout devices.
Unmonitored control circuitry associated with RAS. (See Table 4-2(b) for RAS which include Automatic Reclosing.)	12 Calendar Years	Verify all paths of the control circuits essential for proper operation of the RAS.
Unmonitored control circuitry associated with protective functions inclusive of all auxiliary relays.	12 Calendar Years	Verify all paths of the trip circuits inclusive of all auxiliary relays through the trip coil(s) of the circuit breakers or other interrupting devices.
Control circuitry associated with protective functions and/or RAS whose integrity is monitored and alarmed (See Table 2).	No periodic maintenance specified	None.

Table 2 – Alarming Paths and Monitoring In Tables 1-1 through 1-5, Table 3, Tables 4-1 through 4-2, and Table 5 alarm attributes used to justify extended maximum maintenance intervals and/or reduced maintenance activities are subject to the following maintenance requirements		
Component Attributes	Maximum Maintenance Interval	Maintenance Activities
Any alarm path through which alarms in Tables 1-1 through 1-5, Table 3, Tables 4-1 through 4-2, and Table 5 are conveyed from the alarm origin to the location where corrective action can be initiated, and not having all the attributes of the “Alarm Path with monitoring” category below. Alarms are reported within 24 hours of detection to a location where corrective action can be initiated.	12 Calendar Years	Verify that the alarm path conveys alarm signals to a location where corrective action can be initiated.
Alarm Path with monitoring: The location where corrective action is taken receives an alarm within 24 hours for failure of any portion of the alarming path from the alarm origin to the location where corrective action can be initiated.	No periodic maintenance specified	None.

Table 3 Maintenance Activities and Intervals for distributed UFLS and distributed UVLS Systems		
Component Attributes	Maximum Maintenance Interval	Maintenance Activities
Any unmonitored protective relay not having all the monitoring attributes of a category below.	6 Calendar Years	Verify that settings are as specified. For non-microprocessor relays: <ul style="list-style-type: none"> • Test and, if necessary calibrate. For microprocessor relays: <ul style="list-style-type: none"> • Verify operation of the relay inputs and outputs that are essential to proper functioning of the Protection System. • Verify acceptable measurement of power system input values.
Monitored microprocessor protective relay with the following: <ul style="list-style-type: none"> • Internal self-diagnosis and alarming (See Table 2). • Voltage and/or current waveform sampling three or more times per power cycle, and conversion of samples to numeric values for measurement calculations by microprocessor electronics. Alarming for power supply failure (See Table 2).	12 Calendar Years	Verify: <ul style="list-style-type: none"> • Settings are as specified. • Operation of the relay inputs and outputs that are essential to proper functioning of the Protection System. • Acceptable measurement of power system input values
Monitored microprocessor protective relay with preceding row attributes and the following: <ul style="list-style-type: none"> • Ac measurements are continuously verified by comparison to an independent ac measurement source, with alarming for excessive error (See Table 2). 	12 Calendar Years	Verify only the unmonitored relay inputs and outputs that are essential to proper functioning of the Protection System.

Table 3 Maintenance Activities and Intervals for distributed UFLS and distributed UVLS Systems		
Component Attributes	Maximum Maintenance Interval	Maintenance Activities
<ul style="list-style-type: none"> Some or all binary or status inputs and control outputs are monitored by a process that continuously demonstrates ability to perform as designed, with alarming for failure (See Table 2). Alarming for change of settings (See Table 2).		
Voltage and/or current sensing devices associated with UFLS or UVLS systems.	12 Calendar Years	Verify that current and/or voltage signal values are provided to the protective relays.
Protection System dc supply for tripping non-BES interrupting devices used only for a UFLS or UVLS system.	12 Calendar Years	Verify Protection System dc supply voltage.
Control circuitry between the UFLS or UVLS relays and electromechanical lockout and/or tripping auxiliary devices (excludes non-BES interrupting device trip coils).	12 Calendar Years	Verify the path from the relay to the lockout and/or tripping auxiliary relay (including essential supervisory logic).
Electromechanical lockout and/or tripping auxiliary devices associated only with UFLS or UVLS systems (excludes non-BES interrupting device trip coils).	12 Calendar Years	Verify electrical operation of electromechanical lockout and/or tripping auxiliary devices.
Control circuitry between the electromechanical lockout and/or tripping auxiliary devices and the non-BES interrupting devices in UFLS or UVLS systems, or between UFLS or UVLS relays (with no interposing electromechanical lockout or auxiliary device) and the non-BES interrupting devices (excludes non-BES interrupting device trip coils).	No periodic maintenance specified	None.
Trip coils of non-BES interrupting devices in UFLS or UVLS systems.	No periodic maintenance specified	None.

Table 4-1 Maintenance Activities and Intervals for Automatic Reclosing Components Component Type – Reclosing Relay		
Component Attributes	Maximum Maintenance Interval	Maintenance Activities
Any unmonitored reclosing relay not having all the monitoring attributes of a category below.	6 Calendar Years	Verify that settings are as specified. For non-microprocessor relays: <ul style="list-style-type: none"> • Test and, if necessary calibrate For microprocessor relays: <ul style="list-style-type: none"> • Verify operation of the relay inputs and outputs that are essential to proper functioning of the Automatic Reclosing.
Monitored microprocessor reclosing relay with the following: <ul style="list-style-type: none"> • Internal self-diagnosis and alarming (See Table 2). • Alarming for power supply failure (See Table 2). 	12 Calendar Years	Verify: <ul style="list-style-type: none"> • Settings are as specified. • Operation of the relay inputs and outputs that are essential to proper functioning of the Automatic Reclosing.

Table 4-2(a) Maintenance Activities and Intervals for Automatic Reclosing Components Component Type – Control Circuitry Associated with Reclosing Relays that are NOT an Integral Part of an RAS		
Component Attributes	Maximum Maintenance Interval	Maintenance Activities
Unmonitored Control circuitry associated with Automatic Reclosing that is not an integral part of an RAS.	12 Calendar Years	Verify that Automatic Reclosing, upon initiation, does not issue a premature closing command to the close circuitry.
Control circuitry associated with Automatic Reclosing that is not part of an RAS and is monitored and alarmed for conditions that would result in a premature closing command. (See Table 2)	No periodic maintenance specified	None.

Table 4-2(b) Maintenance Activities and Intervals for Automatic Reclosing Components Component Type – Control Circuitry Associated with Reclosing Relays that ARE an Integral Part of an RAS		
Component Attributes	Maximum Maintenance Interval	Maintenance Activities
Close coils or actuators of circuit breakers or similar devices that are used in conjunction with Automatic Reclosing as part of an RAS (regardless of any monitoring of the control circuitry).	6 Calendar Years	Verify that each close coil or actuator is able to operate the circuit breaker or mitigating device.
Unmonitored close control circuitry associated with Automatic Reclosing used as an integral part of an RAS.	12 Calendar Years	Verify all paths of the control circuits associated with Automatic Reclosing that are essential for proper operation of the RAS.
Control circuitry associated with Automatic Reclosing that is an integral part of an RAS whose integrity is monitored and alarmed. (See Table 2)	No periodic maintenance specified	None.

Table 5 Maintenance Activities and Intervals for Sudden Pressure Relaying		
Note: In cases where Components of Sudden Pressure Relaying are common to Components listed in Table 1-5, the Components only need to be tested once during a distinct maintenance interval.		
Component Attributes	Maximum Maintenance Interval	Maintenance Activities
Any fault pressure relay.	6 Calendar Years	Verify the pressure or flow sensing mechanism is operable.
Electromechanical lockout devices which are directly in a trip path from the fault pressure relay to the interrupting device trip coil (regardless of any monitoring of the control circuitry).	6 Calendar Years	Verify electrical operation of electromechanical lockout devices.
Unmonitored control circuitry associated with Sudden Pressure Relaying.	12 Calendar Years	Verify all paths of the trip circuits inclusive of all auxiliary relays through the trip coil(s) of the circuit breakers or other interrupting devices.
Control circuitry associated with Sudden Pressure Relaying whose integrity is monitored and alarmed (See Table 2).	No periodic maintenance specified	None.

PRC-005 — Attachment A

Criteria for a Performance-Based Protection System Maintenance Program

Purpose: To establish a technical basis for initial and continued use of a performance-based Protection System Maintenance Program (PSMP).

To establish the technical justification for the initial use of a performance-based PSMP:

1. Develop a list with a description of Components included in each designated Segment, with a minimum Segment population of 60 Components.
2. Maintain the Components in each Segment according to the time-based maximum allowable intervals established in Tables 1-1 through 1-5, Table 3, Tables 4-1 through 4-2, and Table 5 until results of maintenance activities for the Segment are available for a minimum of 30 individual Components of the Segment.
3. Document the maintenance program activities and results for each Segment, including maintenance dates and Countable Events for each included Component.
4. Analyze the maintenance program activities and results for each Segment to determine the overall performance of the Segment and develop maintenance intervals.
5. Determine the maximum allowable maintenance interval for each Segment such that the Segment experiences Countable Events on no more than 4% of the Components within the Segment, for the greater of either the last 30 Components maintained or all Components maintained in the previous year.

To maintain the technical justification for the ongoing use of a performance-based PSMP:

1. At least annually, update the list of Components and Segments and/or description if any changes occur within the Segment.
2. Perform maintenance on the greater of 5% of the Components (addressed in the performance based PSMP) in each Segment or 3 individual Components within the Segment in each year.
3. For the prior year, analyze the maintenance program activities and results for each Segment to determine the overall performance of the Segment.
4. Using the prior year's data, determine the maximum allowable maintenance interval for each Segment such that the Segment experiences Countable Events on no more than 4% of the Components within the Segment, for the greater of either the last 30 Components maintained or all Components maintained in the previous year.

If the Components in a Segment maintained through a performance-based PSMP experience 4% or more Countable Events, develop, document, and implement an action plan to reduce the Countable Events to less than 4% of the Segment population within 3 years.

Rationale:

During development of this standard, text boxes were embedded within the standard to explain the rationale for various parts of the standard. Upon BOT approval, the text from the rationale text boxes was moved to this section.

Rationale for Applicability Section:

This section does not reflect the applicability changes that will be proposed by the Project 2014-01 Standards Applicability for Dispersed Generation Resources standards drafting team. The changes in this posted version and those being made by the Project 2014-01 standards drafting team do not overlap.

Additionally, to align with ongoing NERC standards development in Project 2010-05.2: Special Protection Systems, the term “Special Protection Systems” in PRC-005-4 was replaced by the term “Remedial Action Schemes.” These terms are synonymous in the NERC Glossary of Terms.

Rationale for the deletion of part of the definition of Component:

The SDT determined that it was explanatory in nature and adequately addressed in the Supplementary Reference and FAQ Document.

Rationale for R3 Part 3.1:

In the last posting, the SDT included language in the standard that was originally in the implementation plan that required completion of maintenance activities within three years for newly-identified Automatic Reclosing Components following a notification under Requirement R6, which has been removed. After further discussion, the SDT determined that a separate shorter timeframe for maintenance of newly-identified Automatic Reclosing Components created unnecessary complication within the standard. The SDT agreed that entities should be responsible for maintaining the Automatic Reclosing Components subject to the standard, whether existing, newly added or newly within scope based on a change in the largest generating unit in the BA or, if a member of a Reserve Sharing Group, the largest generating unit within the Reserve Sharing Group according to the timeframes in the maintenance tables. Therefore, 3.1 and its subparts have been removed and have not been reinserted into the implementation plan.

Rationale for R4 Part 4.1:

In the last posting, the SDT included language in the standard that was originally in the implementation plan that required completion of maintenance activities within three years for newly-identified Automatic Reclosing Components following a notification under Requirement R6, which has been removed. After further discussion, the SDT determined that a separate shorter timeframe for maintenance of newly-identified Automatic Reclosing Components created unnecessary complication within the standard. The SDT agreed that entities should be responsible for maintaining the Automatic Reclosing Components subject to the standard, whether existing, newly added or newly within scope based on a change in the largest generating unit in the BA or, if a member of a Reserve Sharing Group, the largest generating

unit within the Reserve Sharing Group according to the timeframes in the maintenance tables. Therefore, 4.1 and its subparts have been removed and have not been reinserted into the implementation plan.

Implementation Plan

Project 2014-01 Standards Applicability for Dispersed Power Producing Resources PRC-005-5

Standards Involved

Approval:

- PRC-005-5 – Protection System, Automatic Reclosing, and Sudden Pressure Relaying Maintenance

Retirement:

- PRC-005-4 – Protection System, Automatic Reclosing, and Sudden Pressure Relaying Maintenance

Prerequisite Approvals

N/A

Background

In light of the adoption of a revised “Bulk Electric System” definition by the NERC Board of Trustees (Board), changes to the applicability sections of certain Reliability Standards, including PRC-005, are necessary to align with the implementation of the revised BES definition. The Dispersed Generation Resources Standard Drafting Team (DGR SDT) for Project 2014-01 – Standards Applicability for Dispersed Power Producing Resources has modified the applicability section of certain Generator Owner/Generator Operator requirements to recognize the unique technical and reliability aspects of dispersed power producing resources in order to ensure the applicability of the standards is consistent with the reliable operation of the BES.

General Considerations

Reliability Standard PRC-005-4, with its associated Implementation Plan, was adopted by the Board on November 13, 2014. The DGR SDT has revised the applicability section of PRC-005-4 to align the standard with the revised definition of the BES.

Effective Date

PRC-005-5 shall become effective on the later of the first day following the Effective Date of PRC-005-4 or the first day following approval by an applicable governmental authority or as otherwise provided for in a jurisdiction where approval by an applicable governmental authority is required for a standard to go into effect. Where approval by an applicable governmental authority is not required, the standard shall

become effective on the later of the first day following the Effective Date of PRC-005-4 or the first day of the first calendar quarter after the date the standard is adopted by the Board or as otherwise provided for in that jurisdiction.

Retirement of Existing Standards

PRC-005-4 shall be retired at midnight of the day immediately prior to the Effective Date of PRC-005-5 in the particular jurisdiction in which the revised standard is becoming effective.

Implementation Plan

PRC-005-5 only modifies the applicability for PRC-005-4. All aspects of the Implementation Plan for PRC-005-4 will remain applicable to PRC-005-5 and are incorporated here by reference.

Cross References

The Implementation Plan for the revised definition of “Bulk Electric System” is available [here](#).

The Implementation Plan for PRC-005-4 is available [here](#).

Implementation Plan

Project 2014-01 Standards Applicability for Dispersed Generation

Resources

PRC-005-5

Standards Involved

Approval:

- PRC-005-5 – Protection System and Automatic Reclosing Maintenance

Retirement:

- PRC-005-4 – Protection System and Automatic Reclosing Maintenance

Prerequisite Approvals

N/A

Background

In light of the adoption of a revised “Bulk Electric System” (BES) definition ~~adopted~~ by the NERC Board of Trustees (Board), changes to the applicability sections of certain Reliability Standards, including PRC-005, are necessary to align them with the implementation of the revised BES definition. The Dispersed Generation Resources Standard Drafting Team (DGR SDT) for Project 2014-01 – Standards Applicability for Dispersed Power Producing Generation Resources, has modified the applicability section of certain Generator Owner/Generator Operator requirements to recognize the unique technical and reliability aspects of dispersed power producing resources in order to ensure the applicability of the standards ~~are~~ is consistent with the reliable operation of the BES.

General Considerations

Reliability Standard PRC-005-4, with its associated Implementation Plan, was adopted by the Board on November ~~713, 2013~~ 2014. The DGR SDT has revised the applicability section of PRC-005-4 to align the standard with the revised definition of the BES. ~~in the event that this version of PRC-005 is mandatory and enforceable on the effective date of the revised definition of the BES.~~

Effective Date

PRC-005-5 shall become effective on the later of the first day following the Effective Date~~effective date~~ of PRC-005-4, or the first day~~date following approval~~ ~~that PRC-005-5 is approved~~ by an applicable governmental authority or as otherwise provided for in a jurisdiction where approval by an applicable governmental authority is required for a standard to go into effect. Where approval by an applicable governmental authority is not required, the standard shall become effective on the later of either on the first day following the Effective Date of PRC-005-4 or the first day of the first calendar quarter after

the date the standard is adopted by the Board or as otherwise provided for in that jurisdiction, ~~or 12 months following the effective date of PRC-005-4, whichever is later.~~

Retirement of Existing Standards

PRC-005-4 shall be retired at midnight of the day immediately prior to the effective date of PRC-005-5 in the particular jurisdiction in which the revised standard is becoming effective.

Implementation Plan

PRC-005-5 only modifies the applicability for PRC-005-4. All aspects of the Implementation Plan for PRC-005-4 will remain applicable to PRC-005-5 and are incorporated here by reference.

Cross References

The Implementation Plan for the revised definition of “Bulk Electric System” is available [here](#).

The Implementation Plan for PRC-005-4 is available [here](#).

Standards Authorization Request Form

When completed, please email this form to:
sarcomm@nerc.com

NERC welcomes suggestions to improve the reliability of the bulk power system through improved reliability standards. Please use this form to submit your request to propose a new or a revision to a NERC's Reliability Standard.

Request to propose a new or a revision to a Reliability Standard

Title of Proposed Standard:	Application of certain GO/GOP Reliability Standards and Requirements to Dispersed Generation		
Date Submitted:	10/1/2013		
SAR Requester Information			
Name:	Jennifer Sterling-Exelon, Gary Kruempel-MidAmerican, Allen Schriver-NextEra Energy, Inc., Brian Evans-Mongeon-Utility Services Inc.		
Organization:	Exelon, MidAmerican, NextEra Energy, Utility Services Inc.		
Telephone:	(630) 437-2764 – primary contact	E-mail:	jennifer.sterling@exeloncorp.com primary contact
SAR Type (Check as many as applicable)			
<input type="checkbox"/>	New Standard	<input type="checkbox"/>	Withdrawal of existing Standard
<input checked="" type="checkbox"/>	Revision to existing Standard	<input type="checkbox"/>	Urgent Action

SAR Information

Industry Need (What is the industry problem this request is trying to solve?):

The industry is requesting that the application section of certain GO/GOP Reliability Standards or the requirements of certain GO/GOP Reliability Standards be revised in order to ensure that the Reliability Standards are not imposing requirements on dispersed generation that are unnecessary and/or counterproductive to the reliable operation of the Bulk Electric System (BES). For purposes of this SAR, dispersed generation are those resources that aggregate to a total capacity greater than 75 MVA (gross

SAR Information

nameplate rating), and that are connected through a system designed primarily for delivering such capacity to a common point of connection at a voltage of 100 kV or above.

This request is related to the proposed new definition of the Bulk Electric System (BES) from Project 2010-17, that results in the identification of elements of new dispersed generation facilities that if included under certain Reliability Standards may result in a detriment to reliability or be technically unsound and not useful to the support of the reliable operation of the BES .

Purpose or Goal (How does this request propose to address the problem described above?):

The goal of the request is to revise the applicability of GO/GOP Reliability Standards or the Requirement(s) of GO/GOP Reliability Standards to recognize the unique technical and reliability aspects of dispersed generation, given the proposed new definition of the BES.

Identify the Objectives of the proposed standard’s requirements (What specific reliability deliverables are required to achieve the goal?):

The objective of the revisions to the applicability section and/or Requirements of certain GO/GOP Reliability Standards is to ensure that these revisions are approved by the Board of Trustees and applicable regulatory agencies prior to the effective date for newly identified elements under the proposed BES definition (i.e., June 2016).

Brief Description (Provide a paragraph that describes the scope of this standard action.)

The scope of this SAR involves revisions to the applicability section of the following GO/GOP Reliability Standard applicability sections and/or Reliability Standard Requirements: (a) PRC-005-2 (-3); (b) FAC-008-3; (c) PRC-023-3/PRC-025-1; (d) PRC-004-2a (-3) ; and (e) VAR-002-2 so it is clear what, if any, requirements should apply to dispersed generation. Also, IRO,MOD, PRC or TOP Standards that require outage and protection and control coordination, planning, next day study or real time data or reporting of changes in real and reactive capability should be examined and revised, as needed, to ensure it is clear that these activities and reporting are conducted at the point of aggregation to 75 MVA, and not at an individual turbine, inverter or unit level for dispersed generation. This scope would also include development of a technical guidance paper for standard drafting teams developing new or revised Standards, so that they do not incorrectly apply requirements to dispersed generation unless such an application is technically sound and promotes the reliable operation of the BES.

To the extent, there are existing Reliability Standard Drafting Teams that have the expertise and can make the requested changes prior to the compliance date of newly identified assets under the BES definition (i.e., June 2016), those projects may be assigned the required changes as opposed to creating new projects.

SAR Information

Detailed Description (Provide a description of the proposed project with sufficient details for the standard drafting team to execute the SAR. Also provide a justification for the development or revision of the standard, including an assessment of the reliability and market interface impacts of implementing or not implementing the standard action.)

The following description and technical justification(including an assessment of reliability impacts) is provided for the standard drafting teams to execute the SAR for each applicable Standard.

PRC-005-2

Testing and maintenance of protection and control equipment for dispersed generation should start at the point of aggregation to 75 MVA. Manufacturers of dispersed generation turbines and solar panels recommend against specific testing and maintenance regimes for protection and control equipment at the dispersed generation turbine and panel level. In fact it is counterproductive to implement protection and control at the individual turbine, solar panel, or unit level. Instead this is best done at an aggregated level. Therefore, PRC-005 should indicate that the standard applies at the point of aggregation to at 75 MVA or greater for dispersed generation. This change would clarify that the facility section 4.2.5.3 is the section that would apply to dispersed generating facilities and that the remaining sections would not apply.

FAC-008-3

For dispersed generation, it is unclear if in FAC-008-3 the term “main step up transformer” refers to the padmount transformer at the base of the windmill tower or to the main aggregating transformer that steps up voltage to transmission system voltage. From a technical standpoint, it should be the point of aggregation at 75 MVA or above that is subject to this standard for dispersed generation, such as wind. It is at the point of aggregation at 75 MVA or above that facilities ratings should start, since it is this injection point at which a planner or operator of the system is relying on the amount of megawatts the dispersed generation is providing with consideration of the most limiting element. To require facility ratings at for each dispersed turbine, panel or generating unit is not useful to a planner or operator of the system, and, therefore, FAC-008-3 should be revised to be clear that facility ratings start at the point of aggregation at 75 MVA or above for dispersed generation.

SAR Information

Also consider that the BES definition specifically excludes collector system equipment at less than 75 MVA from being included in the BES. Thus, those portions of the collector systems that handle less than 75 MVA are not BES "Facilities," and, therefore, need not be evaluated per R1 or R2. Given this, there seems to be no technical value to conduct facility ratings for individual dispersed generation turbines, generating units and panels.

PRC-023-3/PRC-025-1

In keeping with the registration criteria for Generator Owners as well as the proposed BES Definition, the 75MVA point of aggregation should be the starting point for application of relay loadability requirements.

PRC-004-2

There is no technical basis to claim that misoperation analysis, corrective action plan implementation and reporting for dispersed generation at the turbine, generating unit or panel level is needed for the reliable operation of the BES. Similar to the statements above, the appropriate point to require misoperation analysis, corrective action plan implementation and reporting is at the point of aggregation at 75 MVA and above.

VAR-002-2

Voltage control for some types of dispersed generating facilities is accomplished by a controller that is able to adjust either generating unit controls or discrete reactive components to provide transmission system voltage adjustment. The VAR-002 standard should be modified to allow this type of control for dispersed generation facilities under the requirements of the standard.

General review of IROs, MODs, PRCs, TOPs

IRO, MOD, PRC or TOP Standards that require outage and protection and control coordination, planning, next day study or real time data or reporting of changes in real and reactive capability should be examined and revised, as needed, to ensure it is clear that these activities are conducted at the point of aggregation at 75 MVA, and not an individual turbine, generating unit or panel level for dispersed generation. Unless this clarity is provided applicability at a finer level of granularity related to dispersed generation may be seen as required and such granularity will result in activities that have no benefit to

Standards Authorization Request Form

SAR Information

reliable operation of the BES. Furthermore applicability at a finer level of granularity will result in unneeded and ineffective collection, analysis, and reporting activities that may result in a detriment to reliability.

Reliability Functions

The Standard will Apply to the Following Functions (Check each one that applies.)

<input type="checkbox"/> Reliability Coordinator	Responsible for the real-time operating reliability of its Reliability Coordinator Area in coordination with its neighboring Reliability Coordinator’s wide area view.
<input type="checkbox"/> Balancing Authority	Integrates resource plans ahead of time, and maintains load-interchange-resource balance within a Balancing Authority Area and supports Interconnection frequency in real time.
<input type="checkbox"/> Interchange Authority	Ensures communication of interchange transactions for reliability evaluation purposes and coordinates implementation of valid and balanced interchange schedules between Balancing Authority Areas.
<input type="checkbox"/> Planning Coordinator	Assesses the longer-term reliability of its Planning Coordinator Area.
<input type="checkbox"/> Resource Planner	Develops a >one year plan for the resource adequacy of its specific loads within a Planning Coordinator area.
<input type="checkbox"/> Transmission Planner	Develops a >one year plan for the reliability of the interconnected Bulk Electric System within its portion of the Planning Coordinator area.
<input type="checkbox"/> Transmission Service Provider	Administers the transmission tariff and provides transmission services under applicable transmission service agreements (e.g., the pro forma tariff).
<input type="checkbox"/> Transmission Owner	Owns and maintains transmission facilities.
<input type="checkbox"/> Transmission Operator	Ensures the real-time operating reliability of the transmission assets within a Transmission Operator Area.

Standards Authorization Request Form

Reliability Functions	
<input type="checkbox"/> Distribution Provider	Delivers electrical energy to the End-use customer.
<input checked="" type="checkbox"/> Generator Owner	Owns and maintains generation facilities.
<input checked="" type="checkbox"/> Generator Operator	Operates generation unit(s) to provide real and reactive power.
<input type="checkbox"/> Purchasing-Selling Entity	Purchases or sells energy, capacity, and necessary reliability-related services as required.
<input type="checkbox"/> Market Operator	Interface point for reliability functions with commercial functions.
<input type="checkbox"/> Load-Serving Entity	Secures energy and transmission service (and reliability-related services) to serve the End-use Customer.

Reliability and Market Interface Principles	
Applicable Reliability Principles (Check all that apply).	
<input checked="" type="checkbox"/>	1. Interconnected bulk power systems shall be planned and operated in a coordinated manner to perform reliably under normal and abnormal conditions as defined in the NERC Standards.
<input type="checkbox"/>	2. The frequency and voltage of interconnected bulk power systems shall be controlled within defined limits through the balancing of real and reactive power supply and demand.
<input checked="" type="checkbox"/>	3. Information necessary for the planning and operation of interconnected bulk power systems shall be made available to those entities responsible for planning and operating the systems reliably.
<input type="checkbox"/>	4. Plans for emergency operation and system restoration of interconnected bulk power systems shall be developed, coordinated, maintained and implemented.
<input checked="" type="checkbox"/>	5. Facilities for communication, monitoring and control shall be provided, used and maintained for the reliability of interconnected bulk power systems.
<input type="checkbox"/>	6. Personnel responsible for planning and operating interconnected bulk power systems shall be trained, qualified, and have the responsibility and authority to implement actions.
<input type="checkbox"/>	7. The security of the interconnected bulk power systems shall be assessed, monitored and maintained on a wide area basis.
<input type="checkbox"/>	8. Bulk power systems shall be protected from malicious physical or cyber attacks.
Does the proposed Standard comply with all of the following Market Interface Principles?	
Enter (yes/no)	
1. A reliability standard shall not give any market participant an unfair competitive advantage.	Yes

Standards Authorization Request Form

Reliability and Market Interface Principles	
2. A reliability standard shall neither mandate nor prohibit any specific market structure.	Yes
3. A reliability standard shall not preclude market solutions to achieving compliance with that standard.	Yes
4. A reliability standard shall not require the public disclosure of commercially sensitive information. All market participants shall have equal opportunity to access commercially non-sensitive information that is required for compliance with reliability standards.	Yes

Related Standards	
Standard No.	Explanation
PRC-005-2, FAC-008-3, PRC-023-3/PRC-025-1/PRC-004-2a, VAR-002-2b and various IRO, MOD, PRC and TOP Standards	See explanation under technical analysis.

Related SARs	
SAR ID	Explanation
	N/A

Standards Authorization Request Form

Related SARs	

Regional Variances	
Region	Explanation
ERCOT	
FRCC	
MRO	
NPCC	
RFC	
SERC	
SPP	
WECC	

Standards Announcement

Project 2014-01 Standards Applicability for Dispersed Generation Resources

PRC-005-5

Final Ballot Now Open through March 11, 2015

[Now Available](#)

A final ballot for **PRC-005-5- Protection System, Automatic Reclosing, and Sudden Pressure Relaying Maintenance** is open through **8 p.m. Eastern, Wednesday, March 11, 2015.**

Background information for this project can be found on the [project page](#).

Instructions for Balloting

In the final ballot, votes are counted by exception. Only members of the ballot pool may cast a ballot; all ballot pool members may change their previously cast votes. A ballot pool member who failed to cast a vote during the last ballot window may cast a vote in the final ballot window. If a ballot pool member cast a vote in the previous ballot and does not participate in the final ballot, that member's vote will be carried over in the final ballot.

Members of the ballot pool associated with this project may log in and submit their vote for the standard by clicking [here](#).

Next Steps

The voting results for the standard will be posted and announced after the ballot window closes. If approved, it will be submitted to the Board of Trustees for adoption and then filed with the appropriate regulatory authorities.

For information on the **Standards Development Process**, please refer to the [Standard Processes Manual](#).

For more information or assistance, please contact Standards Developer, [Katherine Street](#), (via email) or at 404-446-9702.

North American Electric Reliability Corporation

3353 Peachtree Rd, NE

Suite 600, North Tower

Atlanta, GA 30326

404-446-2560 | www.nerc.com

Standards Announcement

Project 2014-01 Standards Applicability for Dispersed Generation Resources - PRC-005-5

Final Ballot Results

[Now Available](#)

A final ballot for **PRC-005-5 - Protection System, Automatic Reclosing, and Sudden Pressure Relaying Maintenance** concluded at **8 p.m. Eastern on Wednesday, March 11, 2015**.

The standard achieved a quorum and sufficient affirmative votes for approval. Voting statistics are listed below, and the [Ballot Results](#) page provides a link to the detailed results for the ballot.

Standard	Quorum / Approval
PRC-005-5	83.52% / 98.03%

Background information for this project can be found on the [project page](#).

Next Steps

The standard will be submitted to the Board of Trustees for adoption and then filed with the appropriate regulatory authorities.

For information on the **Standards Development Process**, refer to the [Standard Processes Manual](#).

For more information or assistance, contact [Arielle Cunningham](#) (via email), Standards Development Administrator, or at 404-446-9653.

North American Electric Reliability Corporation
3353 Peachtree Rd, NE
Suite 600, North Tower
Atlanta, GA 30326
404-446-2560 | www.nerc.com

Log In

- Ballot Pools
- Current Ballots
- Ballot Results
- Registered Ballot Body
- Proxy Voters
- Register

[Home Page](#)

Ballot Results	
Ballot Name:	Project 2014-01-DGR-PRC-005-5_Final_Ballot_March_2015
Ballot Period:	3/2/2015 - 3/11/2015
Ballot Type:	Final
Total # Votes:	299
Total Ballot Pool:	358
Quorum:	83.52 % The Quorum has been reached
Weighted Segment Vote:	98.03 %
Ballot Results:	A quorum was reached and there were sufficient affirmative votes for approval.

Summary of Ballot Results										
Segment	Ballot Pool	Segment Weight	Affirmative		Negative		Negative Vote without a Comment	Abstain	No Vote	
			# Votes	Fraction	# Votes	Fraction				
1 - Segment 1	93	1	63	0.955	3	0.045	0	14	13	
2 - Segment 2	6	0	0	0	0	0	0	5	1	
3 - Segment 3	79	1	57	0.983	1	0.017	0	9	12	
4 - Segment 4	29	1	24	1	0	0	0	2	3	
5 - Segment 5	83	1	54	0.964	2	0.036	0	7	20	
6 - Segment 6	52	1	37	0.974	1	0.026	0	6	8	
7 - Segment 7	2	0	0	0	0	0	0	1	1	
8 - Segment 8	3	0.3	3	0.3	0	0	0	0	0	
9 - Segment 9	3	0.3	3	0.3	0	0	0	0	0	

10 - Segment 10	8	0.7	7	0.7	0	0	0	0	1
Totals	358	6.3	248	6.176	7	0.124	0	44	59

Individual Ballot Pool Results				
Segment	Organization	Member	Ballot	NERC Notes
1	Ameren Services	Eric Scott	Negative	SUPPORTS THIRD PARTY COMMENTS
1	American Electric Power	Paul B Johnson	Affirmative	
1	Arizona Public Service Co.	Brian Cole	Affirmative	
1	Associated Electric Cooperative, Inc.	John Bussman	Affirmative	
1	ATCO Electric	David Downey		
1	Austin Energy	James Armke	Affirmative	
1	Balancing Authority of Northern California	Kevin Smith	Affirmative	
1	Baltimore Gas & Electric Company	Christopher J Scanlon	Affirmative	
1	Beaches Energy Services	Don Cuevas	Affirmative	
1	Black Hills Corp	Wes Wingen		
1	Bonneville Power Administration	Donald S. Watkins	Affirmative	
1	Brazos Electric Power Cooperative, Inc.	Tony Kroskey		
1	Bryan Texas Utilities	John C Fontenot	Affirmative	
1	Central Electric Power Cooperative	Michael B Bax		
1	Central Iowa Power Cooperative	Kevin J Lyons		
1	Central Maine Power Company	Joseph Turano Jr.	Affirmative	
1	City of Tallahassee	Daniel S Langston	Abstain	
1	Clark Public Utilities	Jack Stamper	Affirmative	
1	Cleco Corporation	John Lindsey	Affirmative	
1	Colorado Springs Utilities	Shawna Speer	Affirmative	
1	Consolidated Edison Co. of New York	Christopher L de Graffenried	Affirmative	
1	CPS Energy	Glenn Pressler	Affirmative	
1	Dairyland Power Coop.	Robert W. Roddy	Affirmative	
1	Dominion Virginia Power	Larry Nash	Affirmative	
1	Duke Energy Carolina	Doug E Hils	Affirmative	
1	Entergy Transmission	Oliver A Burke	Affirmative	
1	FirstEnergy Corp.	William J Smith	Affirmative	
1	Florida Keys Electric Cooperative Assoc.	Dennis Minton	Affirmative	
1	Florida Power & Light Co.	Mike O'Neil	Affirmative	
1	Georgia Transmission Corporation	Jason Snodgrass	Affirmative	
1	Great River Energy	Gordon Pietsch	Affirmative	
1	Hydro One Networks, Inc.	Payam Farahbakhsh	Affirmative	
1	Hydro-Quebec TransEnergie	Martin Boisvert	Abstain	
1	Idaho Power Company	Craig Jones	Affirmative	
1	International Transmission Company Holdings Corp	Michael Moltane	Abstain	
1	JDRJC Associates	Jim D Cyrulewski	Abstain	
1	JEA	Ted E Hobson		
1	KAMO Electric Cooperative	Walter Kenyon	Affirmative	
1	Kansas City Power & Light Co.	Daniel Gibson	Affirmative	
1	Lakeland Electric	Larry E Watt		
1	Lincoln Electric System	Doug Bantam	Affirmative	
1	Long Island Power Authority	Robert Ganley		
1	Los Angeles Department of Water & Power	faranak sarbaz		
1	Lower Colorado River Authority	Martyn Turner		
1	M & A Electric Power Cooperative	William Price	Affirmative	
1	Manitoba Hydro	Mike Smith	Affirmative	
1	MEAG Power	Danny Dees	Affirmative	
1	MidAmerican Energy Co.	Terry Harbour	Affirmative	
1	Muscatine Power & Water	Andrew J Kurriger		
1	N.W. Electric Power Cooperative, Inc.	Mark Ramsey	Affirmative	
1	National Grid USA	Michael Jones	Affirmative	
1	NB Power Corporation	Alan MacNaughton	Abstain	
1	Nebraska Public Power District	Jamison Cawley	Affirmative	

1	New York Power Authority	Bruce Metruck	Affirmative	
1	Northeast Missouri Electric Power Cooperative	Kevin White	Affirmative	
1	Northeast Utilities	William Temple	Affirmative	
1	Northern Indiana Public Service Co.	Julaine Dyke	Abstain	
1	Ohio Valley Electric Corp.	Scott R Cunningham	Negative	SUPPORTS THIRD PARTY COMMENTS
1	Oklahoma Gas and Electric Co.	Terri Pyle	Affirmative	
1	Omaha Public Power District	Doug Peterchuck	Affirmative	
1	Oncor Electric Delivery	Rod Kinard	Abstain	
1	Platte River Power Authority	John C. Collins	Affirmative	
1	Portland General Electric Co.	John T Walker	Affirmative	
1	Potomac Electric Power Co.	David Thorne	Abstain	
1	PPL Electric Utilities Corp.	Brenda L Truhe	Abstain	
1	Public Service Electric and Gas Co.	Joseph A Smith	Affirmative	
1	Public Utility District No. 1 of Okanogan County	Dale Dunckel	Affirmative	
1	Puget Sound Energy, Inc.	Denise M Lietz	Affirmative	
1	Rochester Gas and Electric Corp.	John C. Allen	Affirmative	
1	Sacramento Municipal Utility District	Tim Kelley	Affirmative	
1	Salt River Project	Steven C Cobb	Affirmative	
1	San Diego Gas & Electric	Will Speer		
1	SaskPower	Wayne Guttormson	Abstain	
1	Seattle City Light	Pawel Krupa	Affirmative	
1	Seminole Electric Cooperative, Inc.	Mark Churilla	Affirmative	
1	Sho-Me Power Electric Cooperative	Denise Stevens	Affirmative	
1	Snohomish County PUD No. 1	Long T Duong	Affirmative	
1	South Carolina Electric & Gas Co.	Tom Hanzlik	Affirmative	
1	South Carolina Public Service Authority	Shawn T Abrams	Abstain	
1	Southern California Edison Company	Steven Mavis	Affirmative	
1	Southern Company Services, Inc.	Robert A. Schaffeld	Affirmative	
1	Southern Illinois Power Coop.	William Hutchison	Abstain	
1	Southwest Transmission Cooperative, Inc.	John Shaver	Negative	SUPPORTS THIRD PARTY COMMENTS
1	Tacoma Power	John Merrell	Abstain	
1	Tennessee Valley Authority	Howell D Scott	Abstain	
1	Trans Bay Cable LLC	Steven Powell	Affirmative	
1	Tri-State Generation & Transmission Association, Inc.	Tracy Sliman	Affirmative	
1	Tucson Electric Power Co.	John Tolo	Affirmative	
1	U.S. Bureau of Reclamation	Richard T Jackson		
1	United Illuminating Co.	Jonathan Appelbaum	Affirmative	
1	Westar Energy	Kevin Giles	Affirmative	
1	Western Area Power Administration	Steven Johnson	Affirmative	
1	Xcel Energy, Inc.	Gregory L Pieper	Affirmative	
2	BC Hydro	Venkataramakrishnan Vinnakota		
2	Electric Reliability Council of Texas, Inc.	Cheryl Moseley	Abstain	
2	ISO New England, Inc.	Matthew F Goldberg	Abstain	
2	MISO	Marie Knox	Abstain	
2	PJM Interconnection, L.L.C.	stephanie monzon	Abstain	
2	Southwest Power Pool, Inc.	Charles H. Yeung	Abstain	
3	AEP	Michael E Deloach	Affirmative	
3	Alabama Power Company	Robert S Moore	Affirmative	
3	Ameren Corp.	David J Jendras	Negative	COMMENT RECEIVED
3	APS	Sarah Kist	Affirmative	
3	Associated Electric Cooperative, Inc.	Todd Bennett	Affirmative	
3	Avista Corp.	Scott J Kinney		
3	Basin Electric Power Cooperative	Jeremy Voll	Affirmative	
3	Beaches Energy Services	Steven Lancaster	Affirmative	
3	Bonneville Power Administration	Rebecca Berdahl	Affirmative	
3	Central Electric Power Cooperative	Adam M Weber		
3	City of Austin dba Austin Energy	Andrew Gallo	Affirmative	
3	City of Bartow, Florida	Matt Culverhouse	Affirmative	
3	City of Clewiston	Lynne Mila	Affirmative	

3	City of Farmington	Linda R Jacobson	Abstain	
3	City of Green Cove Springs	Mark Schultz	Affirmative	
3	City of Leesburg	Chris Adkins	Affirmative	
3	City of Redding	Bill Hughes	Affirmative	
3	Cleco Corporation	Michelle A Corley	Affirmative	
3	Colorado Springs Utilities	Jean Mueller	Affirmative	
3	ComEd	John Bee	Affirmative	
3	Consolidated Edison Co. of New York	Peter T Yost	Affirmative	
3	Consumers Energy Company	Gerald G Farringer	Affirmative	COMMENT RECEIVED
3	Cowlitz County PUD	Russell A Noble	Affirmative	
3	Dominion Resources, Inc.	Connie B Lowe	Affirmative	
3	DTE Electric	Kent Kujala	Affirmative	
3	FirstEnergy Corp.	Richard S Hoag	Affirmative	
3	Florida Keys Electric Cooperative	Tom B Anthony	Abstain	
3	Florida Municipal Power Agency	Joe McKinney	Affirmative	
3	Florida Power & Light Co.	Summer C. Esquerre		
3	Florida Power Corporation	Lee Schuster		
3	Fort Pierce Utilities Authority	Thomas Parker	Affirmative	
3	Gainesville Regional Utilities	Kenneth Simmons	Affirmative	
3	Great River Energy	Brian Glover		
3	Hydro One Networks, Inc.	Paul Malozewski	Affirmative	
3	JEA	Garry Baker		
3	KAMO Electric Cooperative	Theodore J Hilmes	Affirmative	
3	Kansas City Power & Light Co.	Joshua D Bach	Affirmative	
3	Kissimmee Utility Authority	Gregory D Woessner	Affirmative	
3	Lakeland Electric	Mace D Hunter	Affirmative	
3	Lincoln Electric System	Jason Fortik	Affirmative	
3	Los Angeles Department of Water & Power	Mike Anctil		
3	Louisville Gas and Electric Co.	Charles A. Freibert	Abstain	
3	M & A Electric Power Cooperative	Stephen D Pogue	Affirmative	
3	Manitoba Hydro	Greg C. Parent	Affirmative	
3	MEAG Power	Roger Brand	Affirmative	
3	MidAmerican Energy Co.	Thomas C. Mielnik	Affirmative	
3	Muscatine Power & Water	Seth Shoemaker		
3	N.W. Electric Power Cooperative, Inc.	John Stickley	Affirmative	
3	National Grid USA	Brian E Shanahan	Affirmative	
3	Nebraska Public Power District	Tony Eddleman	Affirmative	
3	New York Power Authority	David R Rivera	Affirmative	
3	Northeast Missouri Electric Power Cooperative	Skyler Wiegmann	Affirmative	
3	Northern Indiana Public Service Co.	Ramon J Barany	Abstain	
3	Ocala Utility Services	Randy Hahn	Affirmative	
3	Oklahoma Gas and Electric Co.	Donald Hargrove	Affirmative	
3	Orlando Utilities Commission	Ballard K Mutters	Affirmative	
3	Owensboro Municipal Utilities	Thomas T Lyons	Abstain	
3	Pacific Gas and Electric Company	John H Hagen	Affirmative	
3	Platte River Power Authority	Terry L Baker	Affirmative	
3	PNM Resources	Michael Mertz		
3	Portland General Electric Co.	Thomas G Ward	Affirmative	
3	Potomac Electric Power Co.	Mark Yerger	Abstain	
3	Public Service Electric and Gas Co.	Jeffrey Mueller	Affirmative	
3	Puget Sound Energy, Inc.	Andrea Basinski		
3	Rutherford EMC	Thomas Haire	Affirmative	
3	Sacramento Municipal Utility District	James Leigh-Kendall	Affirmative	
3	Salt River Project	John T. Underhill	Affirmative	
3	Santee Cooper	James M Poston	Abstain	
3	Seattle City Light	Dana Wheelock	Affirmative	
3	Seminole Electric Cooperative, Inc.	James R Frauen	Affirmative	
3	Snohomish County PUD No. 1	Mark Oens	Affirmative	
3	South Carolina Electric & Gas Co.	Hubert C Young	Affirmative	
3	Tacoma Power	Marc Donaldson	Abstain	
3	Tampa Electric Co.	Ronald L. Donahey		
3	Tennessee Valley Authority	Ian S Grant	Abstain	
3	Tri-State Generation & Transmission Association, Inc.	Janelle Marriott		
3	Westar Energy	Bo Jones	Affirmative	
3	Wisconsin Electric Power Marketing	James R Keller	Affirmative	

3	Xcel Energy, Inc.	Michael Ibold	Affirmative	
4	Alliant Energy Corp. Services, Inc.	Kenneth Goldsmith	Affirmative	
4	Blue Ridge Power Agency	Duane S Dahlquist	Affirmative	
4	City of Austin dba Austin Energy	Reza Ebrahimian	Affirmative	
4	City of New Smyrna Beach Utilities Commission	Tim Beyrle	Affirmative	
4	City of Redding	Nicholas Zettel	Affirmative	
4	City of Winter Park	Mark Brown	Affirmative	
4	City Utilities of Springfield, Missouri	John Allen	Affirmative	
4	Cowlitz County PUD	Rick Syring	Affirmative	
4	DTE Electric	Daniel Herring	Affirmative	
4	Flathead Electric Cooperative	Russ Schneider		
4	Florida Municipal Power Agency	Carol Chinn	Affirmative	
4	Fort Pierce Utilities Authority	Javier Cisneros	Affirmative	
4	Georgia System Operations Corporation	Guy Andrews	Affirmative	
4	Herb Schrayshuen	Herb Schrayshuen	Affirmative	
4	Indiana Municipal Power Agency	Jack Alvey	Abstain	
4	Keys Energy Services	Stan T Rzad	Affirmative	
4	Madison Gas and Electric Co.	Joseph DePoorter	Affirmative	
4	Modesto Irrigation District	Spencer Tacke		
4	Ohio Edison Company	Douglas Hohlbaugh	Affirmative	
4	Oklahoma Municipal Power Authority	Ashley Stringer	Affirmative	
4	Old Dominion Electric Coop.	Mark Ringhausen	Affirmative	
4	Public Utility District No. 1 of Snohomish County	John D Martinsen	Affirmative	
4	Sacramento Municipal Utility District	Mike Ramirez	Affirmative	
4	Seattle City Light	Hao Li	Affirmative	
4	Seminole Electric Cooperative, Inc.	Steven R Wallace	Affirmative	
4	South Mississippi Electric Power Association	Steve McElhaney		
4	Tacoma Public Utilities	Keith Morisette	Abstain	
4	Utility Services, Inc.	Brian Evans-Mongeon	Affirmative	
4	Wisconsin Energy Corp.	Anthony P Jankowski	Affirmative	
5	Acciona Energy North America	George E Brown	Affirmative	
5	Amerenue	Sam Dwyer	Negative	SUPPORTS THIRD PARTY COMMENTS
5	American Electric Power	Thomas Foltz	Affirmative	
5	Arizona Public Service Co.	Scott Takinen	Affirmative	
5	Associated Electric Cooperative, Inc.	Matthew Pacobit	Affirmative	
5	Avista Corp.	Steve Wenke		
5	Basin Electric Power Cooperative	Mike Kraft	Affirmative	
5	BC Hydro and Power Authority	Clement Ma		
5	Boise-Kuna Irrigation District/dba Lucky peak power plant project	Mike D Kukla		
5	Bonneville Power Administration	Francis J. Halpin	Affirmative	
5	Brazos Electric Power Cooperative, Inc.	Shari Heino	Negative	
5	Calpine Corporation	Hamid Zakery	Affirmative	
5	Choctaw Generation Limited Partnership, LLLP	Rob Watson		
5	City of Austin dba Austin Energy	Jeanie Doty	Affirmative	
5	City of Redding	Paul A. Cummings	Affirmative	
5	City of Tallahassee	Karen Webb	Abstain	
5	Cleco Power	Stephanie Huffman	Affirmative	
5	Cogentrix Energy Power Management, LLC	Mike D Hirst		
5	Colorado Springs Utilities	Kaleb Brimhall	Affirmative	
5	Con Edison Company of New York	Brian O'Boyle	Affirmative	
5	Consumers Energy Company	David C Greyerbiehl	Affirmative	
5	Cowlitz County PUD	Bob Essex	Affirmative	
5	Dairyland Power Coop.	Tommy Drea		
5	Dominion Resources Services	Randall C Heise	Affirmative	
5	DTE Electric	Mark Stefaniak	Affirmative	
5	Duke Energy	Dale Q Goodwine	Affirmative	
5	E.ON Climate & Renewables North America, LLC	Karin Schweitzer		
5	Entergy Services, Inc.	Tracey Stubbs	Affirmative	
5	Exelon Nuclear	Mark F Draper	Affirmative	
5	First Wind	John Robertson	Affirmative	
5	FirstEnergy Solutions	Kenneth Dresner	Affirmative	

5	Florida Municipal Power Agency	David Schumann	Affirmative	
5	Great River Energy	Preston L Walsh		
5	Hydro-Québec Production	Roger Dufresne	Abstain	
5	Ingleside Cogeneration LP	Michelle R DAntuono	Affirmative	
5	Invenergy LLC	Alan Beckham	Affirmative	
5	JEA	John J Babik		
5	Kansas City Power & Light Co.	Brett Holland	Affirmative	
5	Kissimmee Utility Authority	Mike Blough	Affirmative	
5	Lakeland Electric	James M Howard		
5	Liberty Electric Power LLC	Daniel Duff	Affirmative	
5	Lincoln Electric System	Dennis Florom	Affirmative	
5	Los Angeles Department of Water & Power	Kenneth Silver		
5	Lower Colorado River Authority	Dixie Wells	Abstain	
5	Luminant Generation Company LLC	Rick Terrill	Affirmative	
5	Manitoba Hydro	Yuguang Xiao	Affirmative	
5	Massachusetts Municipal Wholesale Electric Company	David Gordon	Abstain	
5	MEAG Power	Steven Grego	Affirmative	
5	Muscatine Power & Water	Mike Avesing	Affirmative	
5	Nebraska Public Power District	Don Schmit	Affirmative	
5	Nevada Power Co.	Richard Salgo	Affirmative	
5	New York Power Authority	Wayne Sipperly	Affirmative	
5	NextEra Energy	Allen D Schriver	Affirmative	
5	North Carolina Electric Membership Corp.	Jeffrey S Brame	Affirmative	
5	Northern Indiana Public Service Co.	Michael D Melvin		
5	Oglethorpe Power Corporation	Bernard Johnson	Affirmative	
5	Oklahoma Gas and Electric Co.	Henry L Staples	Affirmative	
5	Omaha Public Power District	Mahmood Z. Safi	Affirmative	
5	Orlando Utilities Commission	Richard K Kinan		
5	Pacific Gas and Electric Company	Alex Chua		
5	Platte River Power Authority	Christopher R Wood	Affirmative	
5	PPL Generation LLC	Annette M Bannon		
5	PSEG Fossil LLC	Tim Kucey	Affirmative	
5	Public Utility District No. 2 of Grant County, Washington	Michiko Sell	Affirmative	
5	Puget Sound Energy, Inc.	Lynda Kupfer	Affirmative	
5	Sacramento Municipal Utility District	Susan Gill-Zobitz	Affirmative	
5	Salt River Project	William Alkema	Affirmative	
5	Santee Cooper	Lewis P Pierce	Abstain	
5	Seattle City Light	Michael J. Haynes	Affirmative	
5	Seminole Electric Cooperative, Inc.	Brenda K. Atkins	Affirmative	
5	Snohomish County PUD No. 1	Sam Nietfeld	Affirmative	
5	South Carolina Electric & Gas Co.	Edward Magic	Affirmative	
5	Southern Company Generation	William D Shultz	Affirmative	
5	Tacoma Power	Chris Mattson	Abstain	
5	Tampa Electric Co.	RJames Rocha		
5	Tennessee Valley Authority	Brandy B Spraker	Abstain	
5	Terra-Gen Power	Jessie Nevarez		
5	Tri-State Generation & Transmission Association, Inc.	Mark Stein		
5	USDI Bureau of Reclamation	Erika Doot		
5	Westar Energy	Stephanie A Johnson	Affirmative	
5	Wisconsin Electric Power Co.	Linda Horn	Affirmative	
5	Wisconsin Public Service Corp.	Scott E Johnson		
5	Xcel Energy, Inc.	Mark A Castagneri	Affirmative	
6	AEP Marketing	Edward P. Cox	Affirmative	
6	Ameren Missouri	Robert Quinlivan	Negative	SUPPORTS THIRD PARTY COMMENTS
6	APS	Randy A. Young	Affirmative	
6	Associated Electric Cooperative, Inc.	Brian Ackermann	Affirmative	
6	Bonneville Power Administration	Brenda S. Anderson	Affirmative	
6	City of Austin dba Austin Energy	Lisa Martin	Affirmative	
6	City of Redding	Marvin Briggs	Affirmative	
6	Cleco Power LLC	Robert Hirchak	Affirmative	
6	Colorado Springs Utilities	Shannon Fair	Affirmative	
6	Con Edison Company of New York	David Balban	Affirmative	

6	Constellation Energy Commodities Group	David J Carlson	Affirmative
6	Dominion Resources, Inc.	Louis S. Slade	Affirmative
6	Duke Energy	Greg Cecil	
6	FirstEnergy Solutions	Kevin Querry	Affirmative
6	Florida Municipal Power Agency	Richard L. Montgomery	Affirmative
6	Florida Municipal Power Pool	Thomas Reedy	Affirmative
6	Florida Power & Light Co.	Silvia P Mitchell	Affirmative
6	Great River Energy	Donna Stephenson	Affirmative
6	Kansas City Power & Light Co.	Jessica L Klinghoffer	Affirmative
6	Lakeland Electric	Paul Shipps	
6	Lincoln Electric System	Eric Ruskamp	Affirmative
6	Los Angeles Department of Water & Power	Brad Packer	
6	Lower Colorado River Authority	Michael Shaw	Abstain
6	Luminant Energy	Brenda Hampton	
6	Manitoba Hydro	Blair Mukanik	Affirmative
6	Modesto Irrigation District	James McFall	Affirmative
6	New York Power Authority	Shivaz Chopra	Affirmative
6	New York State Electric & Gas Corp.	Julie S King	Affirmative
6	Northern Indiana Public Service Co.	Joseph O'Brien	Abstain
6	Oglethorpe Power Corporation	Donna Johnson	Affirmative
6	Oklahoma Gas and Electric Co.	Jerry Nottmagel	Affirmative
6	Omaha Public Power District	Douglas Collins	Affirmative
6	Orlando Utilities Commission	Claston Augustus Sunanon	
6	PacifiCorp	Sandra L Shaffer	Affirmative
6	Platte River Power Authority	Carol Ballantine	Affirmative
6	Portland General Electric Co.	Shawn P Davis	Affirmative
6	Power Generation Services, Inc.	Stephen C Knapp	
6	PPL EnergyPlus LLC	Elizabeth Davis	Abstain
6	PSEG Energy Resources & Trade LLC	Stephen York	Affirmative
6	Sacramento Municipal Utility District	Diane Enderby	Affirmative
6	Salt River Project	William Abraham	Affirmative
6	Santee Cooper	Michael Brown	Abstain
6	Seattle City Light	Dennis Sismaet	Affirmative
6	Seminole Electric Cooperative, Inc.	Trudy S. Novak	Affirmative
6	Snohomish County PUD No. 1	Kenn Backholm	Affirmative
6	Southern Company Generation and Energy Marketing	John J. Ciza	Affirmative
6	Tacoma Public Utilities	Michael C Hill	Abstain
6	Tampa Electric Co.	Benjamin F Smith II	
6	Tennessee Valley Authority	Marjorie S Parsons	Abstain
6	Westar Energy	Tiffany Lake	Affirmative
6	Western Area Power Administration - UGP Marketing	Mark Messerli	
6	Xcel Energy, Inc.	Peter Colussy	Affirmative
7	Luminant Mining Company LLC	Stewart Rake	
7	Siemens Energy, Inc.	Frank R. McElvain	Abstain
8		David L Kiguel	Affirmative
8		Roger C Zaklukiewicz	Affirmative
8	Massachusetts Attorney General	Frederick R Plett	Affirmative
9	City of Vero Beach	Ginny Beigel	Affirmative
9	Commonwealth of Massachusetts Department of Public Utilities	Donald Nelson	Affirmative
9	New York State Public Service Commission	Diane J Barney	Affirmative
10	Florida Reliability Coordinating Council	Linda C Campbell	Affirmative
10	Midwest Reliability Organization	Russel Mountjoy	Affirmative
10	Northeast Power Coordinating Council	Guy V. Zito	Affirmative
10	ReliabilityFirst	Anthony E Jablonski	Affirmative
10	SERC Reliability Corporation	Joseph W Spencer	Affirmative
10	Southwest Power Pool RE	Bob Reynolds	
10	Texas Reliability Entity, Inc.	Derrick Davis	Affirmative
10	Western Electricity Coordinating Council	Steven L. Rueckert	Affirmative



[Legal and Privacy](#) : 404.446.2560 voice : 404.467.0474 fax : 3353 Peachtree Road, N.E. : Suite 600, North Tower : Atlanta, GA 30326
Washington Office: 1325 G Street, N.W. : Suite 600 : Washington, DC 20005-3801

 [Account Log-In/Register](#)

.....
[Copyright](#) © 2015 by the North American Electric Reliability Corporation. : All rights reserved.
A New Jersey Nonprofit Corporation

Summary of Development PRC-005-6

Summary of Development History

The development record for proposed Reliability Standard PRC-005-6 is summarized below.

I. Overview of the Standard Drafting Team

When evaluating a proposed Reliability Standard, the Commission is expected to give “due weight” to the technical expertise of the ERO.¹ The technical expertise of the ERO is derived from the standard drafting team. For this project, the standard drafting team consisted of industry experts, all with a diverse set of experiences. A roster of the standard drafting team members is included in Exhibit J.

II. Standard Development History

A. Standard Authorization Request Development

To address the Commission’s directives in Order No. 803,² NERC revised the Standard Authorization Request (“SAR”) approved by the Standards Committee (“SC”) for the development of Reliability Standard PRC-005-4. The initial SAR was posted for comment from March 12, 2015 through April 10, 2015. The revised SAR was posted for comment from June 11, 2015 through July 10, 2015 and was approved by the SC on July 28, 2015.

B. First Posting - Comment Period, Initial Ballot and Non-Binding Poll

Proposed Reliability Standard PRC-005-6 was posted for a 45-day comment period from July 30, 2015 through September 16, 2015 with an initial ballot held from September 4, 2015 through September 16, 2015. Several documents were posted for guidance with the first draft, including the Unofficial Comment Form, SAR, Violation

¹ Section 215(d)(2) of the Federal Power Act; 16 U.S.C. §824(d) (2) (2012).

² *Protection System Maintenance Reliability Standard*, Order No. 803, 150 FERC ¶ 61,039 (2015).

Risk Factors (“VRFs”) and Violation Severity Levels (“VSLs”) Justification documents, Supplementary Reference and FAQ document and Consideration of Directives. The initial ballot received 86.97% quorum, and 96.73% approval. The Non-Binding Poll received 84.69% quorum and 96.46% of supportive opinions. There were 30 sets of comments, including comments from approximately 108 different individuals from approximately 79 companies, representing 9 of the 10 industry segments.³

C. Final Ballot

Proposed Reliability Standard PRC-005-6 was posted for a 10-day final ballot period from October 15, 2015 through October 26, 2015. The proposed Reliability Standard received 90.00% quorum and 96.38% approval.

D. Board of Trustees Adoption

Proposed Reliability Standard PRC-005-6 was adopted by the NERC Board of Trustees on November 5, 2015.

³ NERC, *Consideration of Comments*, Project 2007-17.4, (November 4, 2015), available at http://www.nerc.com/pa/Stand/Project%20201505%20PRC005%20Order%20No%20803%20Directives%20DL/2007-17_4_PRC-005_Consideration_of_Comments_2015Oct09.pdf.

Complete Record of Development PRC-005-6

Program Areas & Departments > Standards > Project 2007-17.4 PRC-005 FERC Order No. 803 Directive
Project 2007-17.4 PRC-005 FERC Order No. 803 Directive

Related Files

Status

A final ballot for **PRC-005-6– Protection System, Automatic Reclosing, and Sudden Pressure Relaying Maintenance** concluded **8 p.m. Eastern, Monday, October 26, 2015**. The ballot results can be accessed via the links below. The standard will be submitted to the Board of Trustees for adoption and then filed with the appropriate regulatory authorities.

Background

In [Order No. 803](#), FERC approved Standard PRC-005-3 and, in Paragraph 31, directed NERC to:

"...direct that, pursuant to section 215(d)(5) of the FPA, NERC develop modifications to PRC-005-3 to include supervisory devices associated with auto-reclosing relay schemes to which the Reliability Standard applies. Further, we clarify that NERC's proposal regarding the scope of supervisory devices is an acceptable approach to satisfy the Commission directive. Specifically, NERC proposed in its NOPR comments, and we find acceptable, that the scope of the supervisory devices to be encompassed in the Reliability Standard are those providing voltage supervision, supervisory inputs associated with selective auto-reclosing, and sync-check relays that are part of a reclosing scheme covered by PRC-005-3."

In addition, NERC filed a petition for approval of PRC-005-4 on December 18, 2014 and currently a notice of proposed rulemaking has been issued by FERC pending comments due back from industry by June 15, 2014.

PRC-005-5 was adopted by the Board on May 7, 2015 and is pending regulatory filing.

- PRC-005-3 – [Project 2007-17.2 PRC-005 Protection System Maintenance and Testing – Phase 2 \(Reclosing Relays\)](#)
- PRC-005-4 – [Project 2007-17.3 \(PRC-005-X\) Protection System Maintenance and Testing – Phase 3 \(Sudden Pressure Relays\)](#)
- PRC-005-5 – [Project 2014-01 Standards Applicability for Dispersed Generation Resources](#)

Standard(s) Affected: [PRC-005-3](#) - Protection System and Automatic Reclosing Maintenance

Purpose/Industry Need

Provide clear, unambiguous requirements and standard(s) to address the directive in FERC Order 803.

Draft	Actions	Dates	Results	Consideration of Comments
<p>Draft 1</p> <p>PRC-005-6 Clean (41) Redline to Last Posted (42)</p> <p>Redline to Last Approved (PRC-005-5) (43)</p> <p>Implementation Plan Clean (44) Redline to Last Posted (45)</p> <p>Implementation Plan Rationale Clean (46) Redline to Last Posted (47)</p> <p>Supporting Materials</p> <p>Standard Authorization Request Clean (48) Redline to Last Posted (49)</p> <p>Supplementary Reference and FAQ Clean (50) Redline to Last Posted (51)</p> <p>Consideration of Directives Clean (52) Redline to Last Posted (53)</p>	<p>Final Ballot</p> <p>Info (54)</p> <p>Vote</p>	<p>10/15/15 - 10/26/15</p>	<p>Summary (55)</p> <p>Ballot Results (56)</p>	

<p>Draft 1</p> <p>PRC-005-6 Clean (19) Redline to Last Approved (PRC-005-5) (20)</p> <p>Implementation Plan Clean (21) Redline to Last Posted (22)</p> <p>Implementation Plan Rationale (23)</p> <p>Supporting Materials</p> <p>Unofficial Comment Form (Word) (24)</p> <p>Standard Authorization Request Clean (25) Redline to Last Posted (26)</p> <p>VRF/VSL Justification Clean (27) Redline to Last Approved (28)</p> <p>Supplementary Reference and FAQ Clean (29) Redline to Last Posted (30)</p> <p>Consideration of Directives (31)</p> <p>Draft RSAW</p>	<p>Initial Ballot and Non-binding Poll</p> <p>Updated Info (32)</p> <p>Info (33)</p> <p>Vote</p>	09/04/15 - 09/16/15	<p>Summary (36)</p> <p>Ballot Results (37)</p> <p>Non-binding Poll Results (38)</p>	
	<p>Comment Period</p> <p>Info (34)</p> <p>Submit Comments</p>	07/30/15 - 09/16/15	Comments Received (39)	Consideration of Comments (40)
	<p>Join Ballot Pools</p>	07/30/15 - 08/28/15		
	<p>Info (35)</p> <p>Send RSAW feedback to: RSAWfeedback@nerc.net</p>	08/13/15 - 09/16/15		
<p>Second Posting</p> <p>SAR (6)</p> <p>Implementation Plan (7)</p> <p>Implementation Plan Rationale (8)</p> <p>Supporting Materials</p> <p>Unofficial Comment Form (Word) (9)</p>	<p>Comment Period</p> <p>Info (17)</p> <p>Submit Comments</p>	06/11/15 - 07/10/15	Comments Received (18)	

<p>PRC-005-6 Clean (10) Redline to PRC-005-5 (11)</p> <p>VRF/VSL Justification Clean (12) Redline to Last Approved (13)</p> <p>Supplementary Reference and FAQ Clean (14) Redline to Last Posted (15)</p> <p>Consideration of Directives (16)</p>				
<p>SAR (1)</p> <p>Supporting Materials</p> <p>Unofficial Comment Form (Word) (2)</p> <p>Proposed Methodology PRC-005 Directive (3)</p>	<p>Comment Period</p> <p>Info (4)</p> <p>Submit Comments</p>	<p>3/12/15 - 4/10/15</p>	<p>Comments Received (5)</p>	

Standards Authorization Request Form

When completed, email this form to:

Valerie.Agnew@nerc.net

For questions about this form or for assistance in completing the form, call Valerie Agnew at 404-446-2566.

NERC welcomes suggestions for improving the reliability of the Bulk-Power System through improved Reliability Standards. Please use this form to submit your proposal for a new NERC Reliability Standard or a revision to an existing standard.

Request to propose a new or a revision to a Reliability Standard

Proposed Standard:	PRC-005-4		
Date Submitted:	2/12/2014 <u>(Revised March 1, 2015)</u>		
SAR Requester Information			
Name:	Charles Rogers		
Organization:	Protection System Maintenance Standard Drafting Team		
Telephone:	517-788-0027	E-mail:	Charles.Rogers@cmsenergy.com
SAR Type (Check as many as applicable)			
<input type="checkbox"/>	New Standard	<input type="checkbox"/>	Withdrawal of existing Standard
<input checked="" type="checkbox"/>	Revision to existing Standard	<input type="checkbox"/>	Urgent Action

SAR Information

Industry Need (What is the industry problem this request is trying to solve?):

The Federal Energy Regulatory Commission, in paragraphs 11-15 of Order No. 758, accepted NERC's proposal to "develop, either independently or in association with other technical organizations such as IEEE, one or more technical documents which:

1. describe the devices and functions (to include sudden pressure relays which trip for fault conditions) that should address FERC's concern; and
2. propose minimum maintenance activities for such devices and maximum maintenance intervals, including the technical basis for each."

NERC is following through on its commitment to "propose a new or revised standard (e.g. PRC-005) using the NERC Reliability Standards development process to include maintenance of such devices, including establishment of minimum maintenance activities and maximum maintenance intervals." FERC also directed NERC to file an informational filing with a schedule for the development of the changes to the standard.

The NERC System Protection and Control Subcommittee has subsequently issued a technical paper entitled "Sudden Pressure Relays and Other Devices that Respond to Non-Electrical Quantities". The SPCS recommended the following guidance to address the concerns stated in FERC Order No. 758: "Modify PRC-005 to explicitly address maintenance and testing of the actuator device of the sudden pressure relay when applied as a protective device that trips a facility described in the applicability section of the Reliability Standard.

- Develop minimum maintenance activities for sudden pressure relays similar to Table 1-1: Protective Relay. Based on the survey results, the SPCS recommends the maximum interval for time-based maintenance programs be 6 years.
- Modify Table 1-5: Control Circuitry Associated With Protective Functions to explicitly include the sudden pressure control circuitry."

In addition to the above need to address sudden pressure relays, during the development of PRC-005-3, several commenters raised concerns that there is no obligation for the Balancing Authority (BA) to provide the essential data (the largest BES generating unit within the BA area, per Applicability section 4.2.6.1 of PRC-005-3) for the responsible entities to implement PRC-005-3. Modifying the Applicability of PRC-005-2 was determined to be outside the scope of the PRC-005-3 SAR; consequently, the issue was placed in the NERC Issues Database for consideration during the development of PRC-005-4, and therefore is set forth in this SAR to ensure it is within its scope.

SAR Information

SAR Information

Industry Need (What is the industry problem this request is trying to solve?):

Also, during the development of NERC Reliability Standard PRC-025-1, a possible inconsistency between that standard and PRC-005-2 was identified regarding the applicability of generator station service transformers. This issue will be considered during the development of PRC-005-4.

Additionally, the SDT will review the standard to determine if any modifications are necessary to align the standard with changes made to other NERC Reliability Standards, the BES definition, and any other developments that followed the NERC BOT adoption of PRC-005-2 and PRC-005-3.

Finally, NERC staff has requested that possible alternatives to the 24-year record retention period be evaluated by the SDT. During the consideration of PRC-005-2, the Office of Management and Budget requested additional support for the lengthy retention period. Possible solutions include modifying the measures in Section C 'Measures' or the evidence retention in Section D 'Compliance' of the standard.

Modifying the standard as set forth will promote the reliable operation of the Bulk Electric System (BES) by: assuring that sudden pressure relays are properly maintained so they may be expected to perform properly; assuring that the Applicability section of PRC-005-4 accurately reflects the relevant Functional Entities and Facilities; improving consistency with other Reliability Standards and the BES definition.

No market interface impacts are anticipated.

In Order No. 803, FERC approved Standard PRC-005-3 and, in Paragraph 31, directed NERC to:

"...direct that, pursuant to section 215(d)(5) of the FPA, NERC develop modifications to PRC-005-3 to include supervisory devices associated with auto-reclosing relay schemes to which the Reliability Standard applies. Further, we clarify that NERC's proposal regarding the scope of supervisory devices is an acceptable approach to satisfy the Commission directive. Specifically, NERC proposed in its NOPR comments, and we find acceptable, that the scope of the supervisory devices to be encompassed in the Reliability Standard are those providing voltage supervision, supervisory inputs associated with selective auto-reclosing, and sync-check relays that are part of a reclosing scheme covered by PRC-005-3."

SAR Information
Purpose or Goal (How does this request propose to address the problem described above?):
<p>The definition of Protection System may be revised, or a new definition created that describes the relays becoming applicable to the revised standard.</p> <p>The Applicability section of the standard may be modified to: 1) describe explicitly those sudden pressure relays that must be maintained in accordance with the revised standard; 2) include Balancing Authorities; and 3) provide consistency with other Reliability Standards and the BES definition.</p> <p>The tables of minimum maintenance activities and maximum maintenance intervals will be modified or added to include appropriate intervals and activities for sudden pressure relays.</p> <p>The SDT shall consider possible alternatives to the 24-year record retention period in PRC-005-3. Possible solutions include modifying the measures in Section C ‘Measures’ or the evidence retention in Section D ‘Compliance’.</p> <p>The SDT shall consider modifications, as needed, to address any the <u>FERC directives contained in Order 803 that may result</u>ing from the Commission’s consideration of PRC-005-3, which is pending regulatory approval.</p> <p>Finally, the Supplementary Reference Document (provided as a technical reference for PRC-005-43) should be modified to provide the rationale for the maintenance activities and intervals within the revised standard, as well as to provide application guidance to industry.</p>
Identify the Objectives of the proposed standard’s requirements (What specific reliability deliverables are required to achieve the goal?):
<p><u>Provide clear, unambiguous requirements and standard(s) to address the directives in FERC Order 803. The SDT shall consider modifications, as needed, to address any FERC directives or guidance that may result from the Commission’s consideration of PRC-005-4, which is pending regulatory approval, or subsequent versions of the standard that FERC may issue directive(s) for.</u></p> <p>Successful implementation of the revised standard will assure that the sudden pressure relays will perform as needed for the conditions anticipated by those performance requirements.</p>
Brief Description (Provide a paragraph that describes the scope of this standard action.)
<p>The Standard Drafting Team (SDT) shall modify NERC Standard PRC-005-43 to explicitly address the <u>directive in Order 803 maintenance of sudden pressure relays that trip a facility as described in the Applicability section of the Reliability Standard</u>. The SDT shall also consider changes to the standard that</p>

SAR Information

provide consistency and alignment with other Reliability Standards. Additionally, the SDT shall modify the standard to address any directives issued by FERC related to the approval of PRC-005-~~43~~ or subsequent versions of the standard.

Detailed Description (Provide a description of the proposed project with sufficient details for the standard drafting team to execute the SAR. Also provide a justification for the development or revision of the standard, including an assessment of the reliability and market interface impacts of implementing or not implementing the standard action.)

The SDTs execution of this SAR requires the SDT to address the directive in FERC Order 803. The SDT will develop requirement(s) to include supervisory devices associated with auto-reclosing relay schemes to which the Reliability Standard applies. The SDT may elect to propose revisions to the standard regarding the scope of supervisory devices as an acceptable approach to satisfy the Commission directive, as proposed in the NOPR comments submitted by NERC. Specifically, NERC proposed that the scope of the supervisory devices to be encompassed in the Reliability Standard are those providing voltage supervision, supervisory inputs associated with selective auto-reclosing, and sync-check relays that are part of a reclosing scheme covered by PRC-005-3.

The SDT shall also:

1. Consider modifications as needed to address any FERC directives or guidance that may result from the Commission's consideration of PRC-005-4 or subsequent versions of the standard.
2. Revise the Implementation Plans for PRC-005-2, PRC-005-3, PRC-005-4 and subsequent versions of the standard as needed to assure consistent and systematic implementation.
3. Modify the informative Supplementary Reference Document (provided as a technical reference for PRC-005-4) as necessary to provide application guidance to industry.

The drafting team shall:

- ~~1. Consider revising the title of the standard to appropriately include sudden pressure relays.~~
- ~~2. Consider modifying the Purpose of the standard as necessary to address sudden pressure relays.~~
- ~~3. Consider revising the definition of Protection System, or creating a new definition for the applicable sudden pressure relays.~~
- ~~4. Modify the Applicability section of the standard as necessary.~~
- ~~5. Revise or add requirements as necessary.~~
- ~~6. Modify or create additional tables within the standard to include maximum intervals and minimum activities appropriate for the devices being addressed, with consideration for the~~

SAR Information

~~technology of the devices and for any condition monitoring that may be in place for those devices.~~

- ~~7. Modify the measures and Violation Severity Levels as necessary to address the modified requirements.~~
- ~~8. Modify Section C 'Measures' or Section D 'Compliance' of the standard, as needed, to address the 24-year record retention issue.~~
- ~~9. Consider modifications as needed to address any FERC directives that may result from the Commission's consideration of PRC-005-3.~~
- ~~10. Revise the implementation elements for PRC-005-2 and PRC-005-3 as needed to assure consistent and systematic implementation.~~
- ~~11. Modify the informative Supplementary Reference Document (provided as a technical reference for PRC-005-3) to provide the rationale for the maintenance activities and intervals within the modified standard, as well as to provide application guidance to industry.~~

Reliability Functions

The Standard will Apply to the Following Functions (Check each one that applies.)

<input type="checkbox"/> Regional Reliability Organization	Conducts the regional activities related to planning and operations, and coordinates activities of Responsible Entities to secure the reliability of the Bulk Electric System within the region and adjacent regions.
<input type="checkbox"/> Reliability Coordinator	Responsible for the real-time operating reliability of its Reliability Coordinator Area in coordination with its neighboring Reliability Coordinator's wide area view.
<input checked="" type="checkbox"/> Balancing Authority	Integrates resource plans ahead of time, and maintains load-interchange-resource balance within a Balancing Authority Area and supports Interconnection frequency in real time.

Reliability Functions	
<input type="checkbox"/> Interchange Authority	Ensures communication of interchange transactions for reliability evaluation purposes and coordinates implementation of valid and balanced interchange schedules between Balancing Authority Areas.
<input type="checkbox"/> Planning Coordinator	Assesses the longer-term reliability of its Planning Coordinator Area.
<input type="checkbox"/> Resource Planner	Develops a >one year plan for the resource adequacy of its specific loads within a Planning Coordinator area.
<input type="checkbox"/> Transmission Planner	Develops a >one year plan for the reliability of the interconnected Bulk Electric System within its portion of the Planning Coordinator area.
<input type="checkbox"/> Transmission Service Provider	Administers the transmission tariff and provides transmission services under applicable transmission service agreements (e.g., the pro forma tariff).
<input checked="" type="checkbox"/> Transmission Owner	Owens and maintains transmission facilities.
<input type="checkbox"/> Transmission Operator	Ensures the real-time operating reliability of the transmission assets within a Transmission Operator Area.
<input checked="" type="checkbox"/> Distribution Provider	Delivers electrical energy to the End-use customer.
<input checked="" type="checkbox"/> Generator Owner	Owens and maintains generation facilities.
<input type="checkbox"/> Generator Operator	Operates generation unit(s) to provide real and reactive power.
The Standard will Apply to the Following Functions (Check each one that applies.)	
<input type="checkbox"/> Purchasing-Selling Entity	Purchases or sells energy, capacity, and necessary reliability-related services as required.
<input type="checkbox"/> Market Operator	Interface point for reliability functions with commercial functions.
<input type="checkbox"/> Load-Serving Entity	Secures energy and transmission service (and reliability-related services) to serve the End-use Customer.

Reliability and Market Interface Principles

Applicable Reliability Principles (Check all that apply).

<input checked="" type="checkbox"/>	1. Interconnected bulk power systems shall be planned and operated in a coordinated manner to perform reliably under normal and abnormal conditions as defined in the NERC Standards.
<input type="checkbox"/>	2. The frequency and voltage of interconnected bulk power systems shall be controlled within defined limits through the balancing of real and reactive power supply and demand.
<input type="checkbox"/>	3. Information necessary for the planning and operation of interconnected bulk power systems shall be made available to those entities responsible for planning and operating the systems reliably.
<input type="checkbox"/>	4. Plans for emergency operation and system restoration of interconnected bulk power systems shall be developed, coordinated, maintained and implemented.
<input checked="" type="checkbox"/>	5. Facilities for communication, monitoring and control shall be provided, used and maintained for the reliability of interconnected bulk power systems.
<input type="checkbox"/>	6. Personnel responsible for planning and operating interconnected bulk power systems shall be trained, qualified, and have the responsibility and authority to implement actions.
<input type="checkbox"/>	7. The security of the interconnected bulk power systems shall be assessed, monitored and maintained on a wide area basis.
<input type="checkbox"/>	8. Bulk power systems shall be protected from malicious physical or cyber attacks.

Does the proposed Standard comply with all of the following Market Interface Principles?	Enter (yes/no)
1. A reliability standard shall not give any market participant an unfair competitive advantage.	Yes
2. A reliability standard shall neither mandate nor prohibit any specific market structure.	Yes
Does the proposed Standard comply with all of the following Market Interface Principles?	Enter (yes/no)
3. A reliability standard shall not preclude market solutions to achieving compliance with that standard.	Yes
4. A reliability standard shall not require the public disclosure of commercially sensitive information. All market participants shall have equal opportunity to access commercially non-sensitive information that is required for compliance with reliability standards.	Yes

Related Standards	
Standard No.	Explanation

Related SARs	
SAR ID	Explanation

Regional Variances	
Region	Explanation
ERCOT	
FRCC	
MRO	
NPCC	
RFC	
SERC	
SPP	
WECC	

Unofficial Comment Form

Project 2007-17.4 PRC-005 Order No. 803 Directives

DO NOT use this form for submitting comments. Use the [electronic form](#) to submit comments on the SAR. The electronic comment form must be completed by 8:00 p.m. ET on **April 10, 2015**.

If you have questions please contact Stephen Crutchfield via email or by telephone at stephen.crutchfield@nerc.net or 609-651-9455.

The project page may be accessed by [clicking here](#).

Background Information

In Order No. 803, FERC approved Standard PRC-005-3 and, in Paragraph 31, directed NERC to:

"...direct that, pursuant to section 215(d)(5) of the FPA, NERC develop modifications to PRC-005-3 to include supervisory devices associated with auto-reclosing relay schemes to which the Reliability Standard applies. Further, we clarify that NERC's proposal regarding the scope of supervisory devices is an acceptable approach to satisfy the Commission directive. Specifically, NERC proposed in its NOPR comments, and we find acceptable, that the scope of the supervisory devices to be encompassed in the Reliability Standard are those providing voltage supervision, supervisory inputs associated with selective auto-reclosing, and sync-check relays that are part of a reclosing scheme covered by PRC-005-3."

A revised Standards Authorization Request (SAR) was prepared along with a proposal to address the directive. The SAR provides background information regarding the directive. The proposed solution that the PSMTSDT developed to address the directive revises the standard specific defined terms "Automatic Reclosing" and "Component Type" as follows:

Automatic Reclosing – Includes the following Components:

- Reclosing relay
- **Supervisory relay that monitors BES quantities (such as voltage, frequency, or voltage angle) and supervises operation of the reclosing relay**
- **Voltage and Current Sensing Devices associated with the supervisory**
- Control circuitry associated with the reclosing relay **or supervisory relay.**

Component Type –

- Any one of the five specific elements of a Protection System.
- Any one of the ~~two~~-four specific elements of Automatic Reclosing.
- Any one of the two specific elements of Sudden Pressure Relaying.

The term “supervisory relay” was also added as appropriate to Table 4-1. The Rationale section was also revised to reflect the proposed revisions to the defined terms above. A new Table 4-3 was added to address maintenance activities and testing for Automatic Reclosing with supervisory relays. No revisions are being proposed for the Requirements of the standard. This version of PRC-005 uses PRC-005-5 being developer under Project 2014-01 as the starting point for revisions to address the directive.

Questions

1. Do you agree that the scope and objectives of the revised SAR address the directive in Order No. 803? If not, please explain why you do not agree and, if possible, provide specific language revisions that would make it acceptable to you.

- Yes
 No

Comments:

2. The PSTMSDT has proposed revising the definition of “Automatic Reclosing” and “Component Type” to address the FERC directive in Order 803. Do you agree that the proposed revisions to defined terms as shown above address the directive? If not, please provide specific comments regarding the revision and any suggestions for alternatives to address the directive.

- Yes
 No

Comments:

Proposed Methodology

PRC-005 Directive

Directive

In Order No. 803, FERC approved Standard PRC-005-3 and, in Paragraph 31, directed NERC to:

"...direct that, pursuant to section 215(d)(5) of the FPA, NERC develop modifications to PRC-005-3 to include supervisory devices associated with auto-reclosing relay schemes to which the Reliability Standard applies. Further, we clarify that NERC's proposal regarding the scope of supervisory devices is an acceptable approach to satisfy the Commission directive. Specifically, NERC proposed in its NOPR comments, and we find acceptable, that the scope of the supervisory devices to be encompassed in the Reliability Standard are those providing voltage supervision, supervisory inputs associated with selective auto-reclosing, and sync-check relays that are part of a reclosing scheme covered by PRC-005-3."

Proposed Methodology to Address Directive

The proposed solution that the Protection System Maintenance and Testing Standard Drafting Team (PSMTSDT) developed to address the directive revises the standard specific defined terms "Automatic Reclosing" and "Component Type" as follows:

Automatic Reclosing – Includes the following Components:

- Reclosing relay
- **Supervisory relay that monitors BES quantities (such as voltage, frequency, or voltage angle) and supervises operation of the reclosing relay**
- **Voltage and Current Sensing Devices associated with the supervisory**
- Control circuitry associated with the reclosing relay **or supervisory relay.**

Component Type –

- Any one of the five specific elements of a Protection System.
- Any one of the ~~two~~**four** specific elements of Automatic Reclosing.
- Any one of the two specific elements of Sudden Pressure Relaying.

The PSMTSDT also proposes that a new table, Table 4-3, be added to address maintenance activities and testing for Automatic Reclosing with supervisory relays.

**Table 4-3
Maintenance Activities and Intervals for Automatic Reclosing Components
Component Type – Voltage and Current Sensing Devices Associated with Supervisory Relays**

Component Attributes	Maximum Maintenance Interval	Maintenance Activities
Any voltage and current sensing devices not having monitoring attributes of the category below.	12 Calendar Years	Verify that current and voltage signal values are provided to the supervisory relays.
Voltage and Current Sensing devices that are connected to microprocessor supervisory relays with AC measurements are continuously verified by comparison of sensing input value, as measured by the microprocessor relay, to an independent ac measurement source, with alarming for unacceptable error or failure. (See Table 2)	No periodic maintenance specified	None.

No revisions are being proposed for the Requirements of the standard. This version of PRC-005 uses PRC-005-5 being developed under Project 2014-01 as the starting point for revisions to address the directive.

Standards Announcement

Project 2007-17.4 PRC-005 Order No. 803 Directive

SAR Informal Comment Period Now Open Through April 10, 2015

[Now Available](#)

A 30-day informal comment period for the **Project 2007-17.4 PRC-005 Order No. 803 Directive** Standard Authorization Request (SAR) is now open through **8 p.m. Eastern on Friday, April 10, 2015**. The Standard Drafting Team is also seeking input on the **Proposed Methodology PRC-005 Directive** to meet Order No. 803 Directive **during this informal comment period**.

Background information for this project can be found on the [project page](#).

Commenting

Use the [electronic form](#) to submit comments on the SAR and the Proposed Methodology PRC-005 Directive. If you experience any difficulties in using the electronic form, contact [Arielle Cunningham](#). An off-line, unofficial copy of the comment form is posted on the [project page](#).

For information on the **Standards Development Process**, refer to the [Standard Processes Manual](#).

For more information or assistance, contact Senior Standards Developer, [Stephen Crutchfield](#) (via email), or at 609-651-9455.

North American Electric Reliability Corporation
3353 Peachtree Rd, NE
Suite 600, North Tower
Atlanta, GA 30326
404-446-2560 | www.nerc.com

Comments Received Report

Name	2007-17.4 Order 803 Directive PRC-005 SAR
Start Date	3/12/2015
End Date	4/11/2015

The Industry Segments are:

- 1 — Transmission Owners
- 2 — RTOs, ISOs
- 3 — Load-serving Entities
- 4 — Transmission-dependent Utilities
- 5 — Electric Generators
- 6 — Electricity Brokers, Aggregators, and Marketers
- 7 — Large Electricity End Users
- 8 — Small Electricity End Users
- 9 — Federal, State, Provincial Regulatory or other Government Entities
- 10 — Regional Reliability Organizations, Regional Entities

Full Name	Entity Name	Segment(s)	Region	Group Name	Group Member Name	Group Member Organization	Group Member Region
Jason Marshall	ACES Power Marketing	6	MRO,WECC,TRE,SERC,SPP,RF C	ACES Standards Collaborators	Bob Solomon	Hoosier Energy	RFC
					Matt Caves	Western Farmers Electric Cooperative	SPP
					Ellen Watkins	Sunflower Electric Power Corporation	SPP
					Bill Hutchison	Southern Illinois Power Cooperative	SERC
					Ginger Mercier	Prairie Power	SERC
					Scott Brame	North Carolina Electric Membership Corporation	SERC
					Chip Koloini	Golden Spread Electric Cooperative	SPP
					Kevin Lyons	Central Iowa Power Cooperative	MRO
					Ryan Strom	Buckeye Power	RFC
Randi Heise	Dominion - Dominion	5		Dominion - RCS	Larry Nash	Dominion Virginia Power	SERC

	Resources, Inc.				Louis Slade	Dominion Resources, Inc.	SERC
					Connie Lowe	Dominion Resources, Inc.	RFC
					Randi Heise	Dominion Resources, Inc,	NPCC
Michael Lowman	Duke Energy	1,3,5,6	FRCC,SERC,RFC	Duke Ballot Body Members	Doug Hils	Duke Energy	RFC
					Lee Schuster		FRCC
					Dale Goodwine		SERC
					Greg Cecil		RFC
Emily Rousseau	MRO	1,2,3,4,5,6	MRO	MRO-NERC Standards Review Forum (NSRF)	Joe Depoorter	Madison Gas & Electric	MRO
					Amy Casucelli	Xcel Energy	
					Chuck Lawrence	American Transmission Company	
					Chuck Wicklund	Otter Tail Power Company	
					Dan Inman	Minnkota Power Cooperative, Inc	
					Dave Rudolph	Basin Electric Power Cooperative	

					Kayleigh Wilkerson	Lincoln Electric System	
					Jodi Jenson	Western Area Power Administration	
					Larry Heckert	Alliant Energy	
					Mahmood Safi	Omaha Public Utility District	
					Marie Knox	Midwest ISO Inc.	
					Mike Brytowski	Great River Energy	
					Randi Nyholm	Minnesota Power	
					Scott Nickels	Rochester Public Utilities	
					Terry Harbour	MidAmerican Energy Company	
					Tom Breene	Wisconsin Public Service Corporation	
					Tony Eddleman	Nebraska Public Power District	
	Northeast Power	10	NPCC		Alan Adamson	New York State	NPCC

Lee Pedowicz	Coordinating Council			NPCC--RSC-- 2014-04		Reliability Council, LLC	
					David Burke	Orange and Rockland Utilities Inc.	
					Greg Campoli	New York Independent System Operator	
					Sylvain Clermont	Hydro-Quebec TransEnergie	
					Kelly Dash	Consolidated Edison Co. of New York, Inc.	
					Gerry Dunbar	Northeast Power Coordinating Council	
					Kathleen Goodman	ISO - New England	
					Mark Kenny	Northeast Utilities	
					Helen Lainis	Independent Electricity System Operator	
					Alan MacNaughton	New Brunswick Power Corporation	

					Paul Malozewski	Hydro One Networks Inc.	
					Bruce Metruck	New York Power Authority	
					Lee Pedowicz	Northeast Power Coordinating Council	
					Robert Pellegrini	The United Illuminating Company	
					Si Truc Phan	Hydro-Quebec TransEnergie	
					David Ramkalawan	Ontario Power Generation, Inc.	
					Brian Robinson	Utility Services	
					Wayne Sipperly	New York Power Authority	
					Ben Wu	Orange and Rockland Utilities Inc.	
					Peter Yost	Consolidated Edison Co. of New York, Inc.	
					Michael Jones	National Grid	
					Brian Shanahan	National Grid	

					Connie Lowe	Dominion Resources Services, Inc.	
					Silvia Parada Mitchell	NextEra Energy, LLC	
Jeni Renew	SERC Reliability Corporation	10	SERC	SERC PCS	David Greene	SERC	SERC
					John Miller	GTC	
					Joel Masters	SCE&G	
					Charlie Fink	Entergy	
					Ryland Revelle	TVA	
					Steve Edwards	Dominion	
Pamela Hunter	Southern Company - Southern Company Services, Inc.	1,3,5,6	SERC	Southern Company	Robert A. Schaffeld	Southern Company Services, Inc.	SERC
					R. Scott Moore	Alabama Power Company	
					William D. Shultz	Southern Company Generation	
					John J. Ciza	Southern Company Generation and Energy Marketing	
Shannon Mickens	Southwest Power Pool, Inc. (RTO)	2	SPP	SPP Standards Review Group	Shannon Mickens	Southwest Power Pool Inc.	SPP

					Karl Diekevers	Nebraska Public Power District	MRO
					Stephanie Johnson	Westar Energy Inc	SPP
					Bo Jones	Westar Energy Inc	SPP
					Tiffany Lake	Westar Energy Inc	SPP
					Steve Shipps	Westar Energy Inc	SPP
					James Nail	City of Independence , Missouri	SPP
					Kayleigh Wilkerson	Lincoln Electric System	MRO
					Jason Smith	Southwest Power Pool Inc	SPP

Survey Questions

See the *Unofficial Comment Form* on the [Project Page](#) for additional background information.

If you would like to bypass taking the survey, scroll down to submit.

This will allow you to view Social Survey and agree/disagree with an already posted comment using the "thumbs up/thumbs down" feature.

Submitting a "thumbs up/thumbs down" on another entity's comment enables a negative vote to count in the calculation of consensus.

I want to bypass taking the survey.

1. Do you agree that the scope and objectives of the revised SAR address the directive in Order No. 803? If not, please explain why you do not agree and, if possible, provide specific language revisions that would make it acceptable to you.

Yes

No

2. The PSTMSDT has proposed revising the definition of "Automatic Reclosing" and "Component Type" to address the FERC directive in Order 803. Do you agree that the proposed revisions to defined terms as shown above address the directive? If not, please provide specific comments regarding the revision and any suggestions for alternatives to address the directive.

Yes

No

Responses By Question

See the *Unofficial Comment Form* on the [Project Page](#) for additional background information.

Charles Yeung - Southwest Power Pool, Inc. (RTO) - 2 - SPP

Selected Answer:

Answer Comment:

Document Name:

Likes: 0

Dislikes: 0

John Fontenot - Bryan Texas Utilities - 1 -

Selected Answer:

Answer Comment:

Document Name:

Likes: 0

Dislikes: 0

Gul Khan - Oncor Electric Delivery - 1 - TRE

Selected Answer:

Answer Comment:

Document Name:

Likes: 0

Dislikes: 0

Dennis Minton - Florida Keys Electric Cooperative Assoc. - 1 -

Selected Answer:

Answer Comment:

Document Name:

Likes: 0

Dislikes: 0

Amy Casuscelli - Xcel Energy, Inc. - 1,3,5,6 - MRO,WECC,SPP

Selected Answer:

Answer Comment:

Document Name:

Likes: 0

Dislikes: 0

Oliver Burke - Entergy - Entergy Services, Inc. - 1 -

Selected Answer:

Answer Comment:

Document Name:

Likes: 0

Dislikes: 0

Thomas Foltz - AEP - 5 -

Selected Answer:

Answer Comment:

Document Name:

Likes: 0

Dislikes: 0

Emily Rousseau - MRO - 1,2,3,4,5,6 - MRO

Error: Subreport could not be shown.

Selected Answer:

Answer Comment:

Document Name:

Likes: 0

Dislikes: 0

Leonard Kula - Independent Electricity System Operator - 2 -

Selected Answer:

Answer Comment:

Document Name:

Likes: 0

Dislikes: 0

RoLynda Shumpert - SCANA - South Carolina Electric and Gas Co. - 1,3,5,6 - SERC

Selected Answer:

Answer Comment:

Document Name:

Likes: 0

Dislikes: 0

David Jendras - Ameren - Ameren Services - 3 -

Selected Answer:

Answer Comment:

Document Name:

Likes: 0

Dislikes: 0

Michelle D'Antuono - Oxy - Ingleside Cogeneration LP - 5 -

Selected Answer:

Answer Comment:

Document Name:

Likes: 0

Dislikes: 0

Michelle D'Antuono - Oxy - Ingleside Cogeneration LP - 5 -

Selected Answer:

Answer Comment:

Document Name:

Likes: 0

Dislikes: 0

Andrew Puztai - American Transmission Company, LLC - 1 -

Selected Answer:

Answer Comment:

Document Name:

Likes: 0

Dislikes: 0

Kathleen Black - DTE Energy - 3,4,5 - RFC

Selected Answer:

Answer Comment:

Document Name:

Likes: 0

Dislikes: 0

Pamela Hunter - Southern Company - Southern Company Services, Inc. - 1,3,5,6 - SERC

Error: Subreport could not be shown.

Selected Answer:

Answer Comment:

Document Name:

Likes: 0

Dislikes: 0

Rachel Coyne - Texas Reliability Entity, Inc. - 10 -

Selected Answer:

Answer Comment:

Document Name:

Likes: 0

Dislikes: 0

David Kiguel - David Kiguel - 8 -

Selected Answer:

Answer Comment:

Document Name:

Likes: 0

Dislikes: 0

John Merrell - Tacoma Public Utilities (Tacoma, WA) - 1 -

Selected Answer:

Answer Comment:

Document Name:

Likes: 0

Dislikes: 0

christina bigelow - Electric Reliability Council of Texas, Inc. - 2 -

Selected Answer:

Answer Comment:

Document Name:

Likes: 0

Dislikes: 0

Lee Pedowicz - Northeast Power Coordinating Council - 10 - NPCC

Error: Subreport could not be shown.

Selected Answer:

Answer Comment:

Document Name:

Likes: 0

Dislikes: 0

Si Truc Phan - Hydro-Qu?bec TransEnergie - 1 - NPCC

Selected Answer:

Answer Comment:

Document Name:

Likes: 0

Dislikes: 0

Mike Smith - Manitoba Hydro - 1 -

Selected Answer:

Answer Comment:

Document Name:

Likes: 0

Dislikes: 0

Michael Lowman - Duke Energy - 1,3,5,6 - FRCC,SERC,RFC

Error: Subreport could not be shown.

Selected Answer:

Answer Comment:

Document Name:

Likes: 0

Dislikes: 0

Dan Bamber - ATCO Electric - 1 - WECC

Selected Answer:

Answer Comment:

Document Name:

Likes: 0

Dislikes: 0

Randi Heise - Dominion - Dominion Resources, Inc. - 5 -

Error: Subreport could not be shown.

Selected Answer:

Answer Comment:

Document Name:

Likes: 0

Dislikes: 0

Andy Bolivar - NextEra Energy - Florida Power and Light Co. - 1 - FRCC,TRE,NPCC

Selected Answer:

Answer Comment:

Document Name:

Likes: 0

Dislikes: 0

Jeni Renew - SERC Reliability Corporation - 10 - SERC

Error: Subreport could not be shown.

Selected Answer:

Answer Comment:

Document Name:

Likes: 0

Dislikes: 0

Molly Devine - IDACORP - Idaho Power Company - 1 -

Selected Answer:

Answer Comment:

Document Name:

Likes: 0

Dislikes: 0

Dennis Chastain - Tennessee Valley Authority - 1,3,5,6 - SERC

Selected Answer:

Answer Comment:

Document Name:

Likes: 0

Dislikes: 0

Paul Malozewski - Hydro One Networks, Inc. - 3 -

Selected Answer:

Answer Comment:

Document Name:

Likes: 1 Hydro One Networks, Inc., 1, Farahbakhsh Payam

Dislikes: 0

Payam Farahbakhsh - Hydro One Networks, Inc. - 1 -

Selected Answer:

Answer Comment:

Document Name:

Likes: 0

Dislikes: 0

Jason Marshall - ACES Power Marketing - 6 - MRO,WECC,TRE,SERC,SPP,RFC

Error: Subreport could not be shown.

Selected Answer:

Answer Comment:

Document Name:

Likes: 0

Dislikes: 0

Shannon Mickens - Southwest Power Pool, Inc. (RTO) - 2 - SPP

Error: Subreport could not be shown.

Selected Answer:

Answer Comment:

Document Name:

Likes: 0

Dislikes: 0

Chris Gowder - Florida Municipal Power Agency - 3,4,5,6 - FRCC

Selected Answer:

Answer Comment:

Document Name:

Likes: 0

Dislikes: 0

Fuchsia Davis - Bonneville Power Administration - 1,3,5,6 - WECC

Selected Answer:

Answer Comment:

Document Name:

Likes: 0

Dislikes: 0

Shannon Fair - Colorado Springs Utilities - 6 -

Selected Answer:

Answer Comment:

Document Name:

Likes: 0

Dislikes: 0

If you would like to bypass taking the survey, scroll down to submit.

This will allow you to view Social Survey and agree/disagree with an already posted comment using the "thumbs up/thumbs down" feature.

Submitting a "thumbs up/thumbs down" on another entity's comment enables a negative vote to count in the calculation of consensus.

Charles Yeung - Southwest Power Pool, Inc. (RTO) - 2 - SPP

Selected Answer: I want to bypass taking the survey.

Answer Comment:

Document Name:

Likes: 0

Dislikes: 0

John Fontenot - Bryan Texas Utilities - 1 -

Selected Answer:

Answer Comment:

Document Name:

Likes: 0

Dislikes: 0

Gul Khan - Oncor Electric Delivery - 1 - TRE

Selected Answer:

Answer Comment:

Document Name:

Likes: 0

Dislikes: 0

Dennis Minton - Florida Keys Electric Cooperative Assoc. - 1 -

Selected Answer: I want to bypass taking the survey.

Answer Comment:

Document Name:

Likes: 0

Dislikes: 0

Amy Casuscelli - Xcel Energy, Inc. - 1,3,5,6 - MRO,WECC,SPP

Selected Answer:

Answer Comment:

Document Name:

Likes: 0

Dislikes: 0

Oliver Burke - Entergy - Entergy Services, Inc. - 1 -

Selected Answer:

Answer Comment:

Document Name:

Likes: 0

Dislikes: 0

Thomas Foltz - AEP - 5 -

Selected Answer:

Answer Comment:

Document Name:

Likes: 0

Dislikes: 0

Emily Rousseau - MRO - 1,2,3,4,5,6 - MRO

Error: Subreport could not be shown.

Selected Answer:

Answer Comment:

Document Name:

Likes: 0

Dislikes: 0

Leonard Kula - Independent Electricity System Operator - 2 -

Selected Answer:

Answer Comment:

Document Name:

Likes: 0

Dislikes: 0

RoLynda Shumpert - SCANA - South Carolina Electric and Gas Co. - 1,3,5,6 - SERC

Selected Answer: I want to bypass taking the survey.

Answer Comment:

Document Name:

Likes: 0

Dislikes: 0

David Jendras - Ameren - Ameren Services - 3 -

Selected Answer:

Answer Comment:

Document Name:

Likes: 0

Dislikes: 0

Michelle D'Antuono - Oxy - Ingleside Cogeneration LP - 5 -

Selected Answer: I want to bypass taking the survey.

Answer Comment:

Document Name:

Likes: 0

Dislikes: 0

Michelle D'Antuono - Oxy - Ingleside Cogeneration LP - 5 -

Selected Answer: I want to bypass taking the survey.

Answer Comment:

Document Name:

Likes: 0

Dislikes: 0

Andrew Pusztai - American Transmission Company, LLC - 1 -

Selected Answer:

Answer Comment:

Document Name:

Likes: 0

Dislikes: 0

Kathleen Black - DTE Energy - 3,4,5 - RFC

Selected Answer:

Answer Comment:

Document Name:

Likes: 0

Dislikes: 0

Pamela Hunter - Southern Company - Southern Company Services, Inc. - 1,3,5,6 - SERC

Error: Subreport could not be shown.

Selected Answer:

Answer Comment:

Document Name:

Likes: 0

Dislikes: 0

Rachel Coyne - Texas Reliability Entity, Inc. - 10 -

Selected Answer:

Answer Comment:

Document Name:

Likes: 0

Dislikes: 0

David Kiguel - David Kiguel - 8 -

Selected Answer:

Answer Comment:

Document Name:

Likes: 0

Dislikes: 0

John Merrell - Tacoma Public Utilities (Tacoma, WA) - 1 -

Selected Answer:

Answer Comment:

Document Name:

Likes: 0

Dislikes: 0

christina bigelow - Electric Reliability Council of Texas, Inc. - 2 -

Selected Answer:

Answer Comment:

Document Name:

Likes: 0

Dislikes: 0

Lee Pedowicz - Northeast Power Coordinating Council - 10 - NPCC

Error: Subreport could not be shown.

Selected Answer:

Answer Comment:

Document Name:

Likes: 1 Hydro-Qu?bec TransEnergie, 1, Phan Si Truc

Dislikes: 0

Si Truc Phan - Hydro-Qu?bec TransEnergie - 1 - NPCC

Selected Answer:

Answer Comment:

Document Name:

Likes: 0

Dislikes: 0

Mike Smith - Manitoba Hydro - 1 -

Selected Answer:

Answer Comment:

Document Name:

Likes: 0

Dislikes: 0

Michael Lowman - Duke Energy - 1,3,5,6 - FRCC,SERC,RFC

Error: Subreport could not be shown.

Selected Answer:

Answer Comment:

Document Name:

Likes: 0

Dislikes: 0

Dan Bamber - ATCO Electric - 1 - WECC

Selected Answer:

Answer Comment:

Document Name:

Likes: 0

Dislikes: 0

Randi Heise - Dominion - Dominion Resources, Inc. - 5 -

Error: Subreport could not be shown.

Selected Answer:

Answer Comment:

Document Name:

Likes: 0

Dislikes: 0

Andy Bolivar - NextEra Energy - Florida Power and Light Co. - 1 - FRCC,TRE,NPCC

Selected Answer:

Answer Comment:

Document Name:

Likes: 0

Dislikes: 0

Jeni Renew - SERC Reliability Corporation - 10 - SERC

Error: Subreport could not be shown.

Selected Answer:

Answer Comment:

Document Name:

Likes: 0

Dislikes: 0

Molly Devine - IDACORP - Idaho Power Company - 1 -

Selected Answer:

Answer Comment:

Document Name:

Likes: 0

Dislikes: 0

Dennis Chastain - Tennessee Valley Authority - 1,3,5,6 - SERC

Selected Answer:

Answer Comment:

Document Name:

Likes: 0

Dislikes: 0

Paul Malozewski - Hydro One Networks, Inc. - 3 -

Selected Answer:

Answer Comment:

Document Name:

Likes: 0

Dislikes: 0

Payam Farahbakhsh - Hydro One Networks, Inc. - 1 -

Selected Answer: I want to bypass taking the survey.

Answer Comment:

Document Name:

Likes: 0

Dislikes: 0

Jason Marshall - ACES Power Marketing - 6 - MRO,WECC,TRE,SERC,SPP,RFC

Error: Subreport could not be shown.

Selected Answer:

Answer Comment:

Document Name:

Likes: 0

Dislikes: 0

Shannon Mickens - Southwest Power Pool, Inc. (RTO) - 2 - SPP

Error: Subreport could not be shown.

Selected Answer:

Answer Comment:

Document Name:

Likes: 0

Dislikes: 0

Chris Gowder - Florida Municipal Power Agency - 3,4,5,6 - FRCC

Selected Answer:

Answer Comment:

Document Name:

Likes: 0

Dislikes: 0

Fuchsia Davis - Bonneville Power Administration - 1,3,5,6 - WECC

Selected Answer:

Answer Comment:

Document Name:

Likes: 0

Dislikes: 0

Shannon Fair - Colorado Springs Utilities - 6 -

Selected Answer:

Answer Comment:

Document Name:

Likes: 0

Dislikes: 0

1. Do you agree that the scope and objectives of the revised SAR address the directive in Order No. 803? If not, please explain why you do not agree and, if possible, provide specific language revisions that would make it acceptable to you.

Charles Yeung - Southwest Power Pool, Inc. (RTO) - 2 - SPP

Selected Answer:

Answer Comment:

Document Name:

Likes: 0

Dislikes: 0

John Fontenot - Bryan Texas Utilities - 1 -

Selected Answer: Yes

Answer Comment:

Document Name:

Likes: 0

Dislikes: 0

Gul Khan - Oncor Electric Delivery - 1 - TRE

Selected Answer: Yes

Answer Comment:

Document Name:

Likes: 0

Dislikes: 0

Dennis Minton - Florida Keys Electric Cooperative Assoc. - 1 -

Selected Answer:

Answer Comment:

Document Name:

Likes: 0

Dislikes: 0

Amy Casuscelli - Xcel Energy, Inc. - 1,3,5,6 - MRO,WECC,SPP

Selected Answer: Yes

Answer Comment:

Document Name:

Likes: 0

Dislikes: 0

Oliver Burke - Entergy - Entergy Services, Inc. - 1 -

Selected Answer: No

Answer Comment:

Entergy support comments of the SERC Protection and Control Subcommittee (PCS).

Document Name:

Likes: 0

Dislikes: 0

Thomas Foltz - AEP - 5 -

Selected Answer: No

Answer Comment:

AEP believes the overall scope and objectives of the revised SAR are appropriate, however as discussed below, a definition needs to be drafted for “supervisory relay” so that it is clear exactly which devices are, and are-not, supervisory relays. As such, the SAR should be modified to accommodate the addition of this definition.

Document Name:

Likes: 0

Dislikes: 0

Emily Rousseau - MRO - 1,2,3,4,5,6 - MRO

Error: Subreport could not be shown.

Selected Answer: No

Answer Comment:

The consideration of the applicability of generator station service transformers, and possible inconsistency with PRC-025-1, is not mentioned anywhere in FERC

Order No. 803, contradicts the BES Definition application process, exceeds the scope of the mandate, and should be removed from the SAR. The NSRF believes that this may have been left in this version of the SAR since the original SAR has been updated for this Project.

There is no conflict with PRC-025-1. The Applicability section of PRC-025-1 only capitalizes "Facilities" as a subsection heading, not to indicate BES Element per the defined term. "The following Elements associated with Bulk Electric System (BES) generating units..." proves this, as Element is defined as any electrical device, not necessarily BES. The Elements are only associated with BES Elements, otherwise Section 3.2 would just read "The following BES Elements...". FERC Order No. 733, paragraph 104, directs NERC to address Unit Auxiliary Transformers in PRC-025; there is no equivalent direction in Order No. 803 for PRC-005.

These are no BES Elements per the BES Definition. Per the NERC Bulk Electric System Definition Reference Document, April 2014, page 12: "The presence of a system service, a station service, or a generator auxiliary transformer does not affect the application of Inclusion I2. Transformers associated with system service, station service, or generator auxiliaries are evaluated under the core definition and Inclusion I1." They do not meet I1: "Transformers with the primary terminal and at least one secondary terminal operated at 100 kV or higher...", are not BES Elements, and do not belong in PRC-005.

We understand this paragraph is legacy wording from the previous recycled SAR. It would be best to remove it before this SAR is finalized.

Document Name:

Likes: 0

Dislikes: 0

Leonard Kula - Independent Electricity System Operator - 2 -

Selected Answer: Yes

Answer Comment:

Document Name:

Likes: 0

Dislikes: 0

RoLynda Shumpert - SCANA - South Carolina Electric and Gas Co. - 1,3,5,6 - SERC

Selected Answer:

Answer Comment:

Document Name:

Likes: 0

Dislikes: 0

David Jendras - Ameren - Ameren Services - 3 -

Selected Answer: Yes

Answer Comment:

Document Name:

Likes: 0

Dislikes: 0

Michelle D'Antuono - Oxy - Ingleside Cogeneration LP - 5 -

Selected Answer:

Answer Comment:

Document Name:

Likes: 0

Dislikes: 0

Michelle D'Antuono - Oxy - Ingleside Cogeneration LP - 5 -

Selected Answer: Yes

Answer Comment:

Ingleside Cogeneration LP (ICLP) agrees that the project team has captured FERC's language and intent in the SAR for Project 2007-17.4. However, we agree with a number of respondents to Order 803 that the reliability costs do not match the expected benefit. As a result, we would like to see the project team solicit this kind of information from stakeholders for further analysis. We believe that this supports the Risk-based processes that NERC has been moving toward – realizing that scarce resources expended on low-value initiatives takes attention away for more pressing ones (e.g.; cyber security and frequency response.)

Document Name:

Likes: 0

Dislikes: 0

Andrew Pusztai - American Transmission Company, LLC - 1 -

Selected Answer: Yes

Answer Comment:

Document Name:

Likes: 0

Dislikes: 0

Kathleen Black - DTE Energy - 3,4,5 - RFC

Selected Answer: Yes

Answer Comment:

Document Name:

Likes: 0

Dislikes: 0

Pamela Hunter - Southern Company - Southern Company Services, Inc. - 1,3,5,6 - SERC

Error: Subreport could not be shown.

Selected Answer: No

Answer Comment:

a) The Directive does not specifically require the addition "Voltage and Current Sensing Devices associated with the supervisory".

b) Although we do not disagree that the appropriate voltage needed to determine 'hot vs dead line' and 'synch check' associated with reclosing schemes should be verified at the appropriate input to the supervisory relays, the devices themselves should not be included. See suggested solution in 2c.

- c) The SAR should be fresh and not drag along with it the original PRC-005-4 SAR wording – that previous SAR has already been vetted, voted, and the work resulting from it is already pending FERC approval.
- d) The SAR indicates various versions of the standards as the finished product – these conflicts should be resolved (won't the product of this drafting work be -6?)
- e) The SAR should be clean and only address the FERC Order 803. The red text at the bottom of page 3 of the SAR should be the content of the Industry Need section.
- f) The second paragraph of the Purpose or Goal section of the SAR is not needed.
- g) In the Detailed Description paragraph, suggest changing Item 2 from "Revise the implementation plans of PRC-005-2, PRC-005-3, ... to assure consistent and systematic implementation." to "Revise the implementation plans of PRC-005-3, to assure practically possible implementation." [note that PRC-005-2 has been removed and words have been changed].

Document Name:

Likes: 0

Dislikes: 0

Rachel Coyne - Texas Reliability Entity, Inc. - 10 -

Selected Answer: Yes

Answer Comment:

Document Name:

Likes: 0

Dislikes: 0

David Kiguel - David Kiguel - 8 -

Selected Answer: Yes

Answer Comment:

Document Name:

Likes: 0

Dislikes: 0

John Merrell - Tacoma Public Utilities (Tacoma, WA) - 1 -

Selected Answer: Yes

Answer Comment:

Document Name:

Likes: 0

Dislikes: 0

christina bigelow - Electric Reliability Council of Texas, Inc. - 2 -

Selected Answer: Yes

Answer Comment:

ERCOT references and supports the comments provided by the ISO/RTO Standards

Review Committee.

Document Name:

Likes: 0

Dislikes: 0

Lee Pedowicz - Northeast Power Coordinating Council - 10 - NPCC

Error: Subreport could not be shown.

Selected Answer: No

Answer Comment:

The Objective section on page 4 of the SAR should be revised to stipulate the revisions that will be needed for Automatic Reclosing, and Component Type that are listed in the Definitions Used in this Standard section of PRC-005-3. (The Proposed Methodology - PRC-005 Directive states on its page 2 that "This version of PRC-005 uses PRC-005-5 being developed under Project 2014-01 as the starting point for revisions to address the directive.") Suggest revising the Objectives section in the SAR to read "Provide clear, unambiguous requirements, standard specific definitions, and standard(s)..."

Document Name:

Likes: 1 Hydro-Qu?bec TransEnergie, 1, Phan Si Truc

Dislikes: 0

Si Truc Phan - Hydro-Qu?bec TransEnergie - 1 - NPCC

Selected Answer: No

Answer Comment:

Hydro-Quebec TransEnergie supports comments from RSC-NPCC

Document Name:

Likes:

0

Dislikes:

0

Mike Smith - Manitoba Hydro - 1 -

Selected Answer:

Yes

Answer Comment:

Document Name:

Likes:

0

Dislikes:

0

Michael Lowman - Duke Energy - 1,3,5,6 - FRCC,SERC,RFC

Error: Subreport could not be shown.

Selected Answer:

Yes

Answer Comment:

Document Name:

Likes: 0

Dislikes: 0

Dan Bamber - ATCO Electric - 1 - WECC

Selected Answer: No

Answer Comment:

Supervisory relay and voltage and current sensing devices are required on elements that need true synchronization. The sync-check required elements are at generating sites or on interconnecting elements that tie two transmission systems together.

Elements within a transmission system have limited sync-check functionality that can be by-passed. Does required maintenance in Table 4-3 actually enhance reliability on the BES? Can the maintenance cost out-weight the reliability benefits?

Document Name:

Likes: 0

Dislikes: 0

Randi Heise - Dominion - Dominion Resources, Inc. - 5 -

Error: Subreport could not be shown.

Selected Answer: Yes

Answer Comment:

Document Name:

Likes: 0

Dislikes: 0

Andy Bolivar - NextEra Energy - Florida Power and Light Co. - 1 - FRCC,TRE,NPCC

Selected Answer: Yes

Answer Comment:

*NHT is in general agreement with the revised scope/objective included in this SAR regarding the addition of Supervisory type relays and voltage/current sensing devices. However, this revision when combined with the terminology "control circuitry associated with the reclosing relay or supervisory relay" (as stated in **Proposed Methodology** PRC-005 Directive bullet 4) may lead to misinterpretation by end users. Use of the terminology provided in the SAR may imply that circuit breaker"control circuit" testing will need to include formal "close (circuit) checks" to verify integrity of the entire close circuit. This may lead to unnecessary cycling/wear and tear of circuit breakers. Recommend that "bullet 4" be entirely eliminated or consider modifying the language in bullet 4 to "close circuitry **interconnections** associated with the reclosing relay or supervisor relay"*

Document Name:

Likes: 0

Dislikes: 0

Jeni Renew - SERC Reliability Corporation - 10 - SERC

Error: Subreport could not be shown.

Selected Answer: No

Answer Comment:

1) The Directive specifically required the addition of the "Supervisory relay that

monitors BES quantities (such as voltage, frequency, or voltage angle) and supervises operation of the reclosing relay” but does not require the addition of the “Voltage and Current Sensing Devices associated with the supervisory”. The addition of the “Voltage and Current Sensing Devices” seems to be an increase in scope relative to the original Directive.

To make the language acceptable, remove all requirements for Voltage and Current Sensing Devices associated with supervisory relays.

Document Name:

Likes: 1 SCANA - South Carolina Electric and Gas Co., 1,3,5,6, Shumpert RoLynda

Dislikes: 0

Molly Devine - IDACORP - Idaho Power Company - 1 -

Selected Answer: Yes

Answer Comment:

Document Name:

Likes: 0

Dislikes: 0

Dennis Chastain - Tennessee Valley Authority - 1,3,5,6 - SERC

Selected Answer: No

Answer Comment:

The proposed language is an expansion of scope beyond the directive in that it includes “Voltage and Current Sensing Devices associated with supervisory relays”, which is not a requirement of the directive. To make this language acceptable,

please remove all requirements for "Voltage and Current Sensing Devices associated with supervisory relays".

As currently proposed, the scope of this SAR is not clear. The cover page suggests that version 4 is being proposed by this SAR, while other edits suggest we are considering version 6. Superfluous information has been retained from the issue of this document as the SAR for PRC-005-4. Consequently, the "Industry Need" section is unnecessarily muddled. From the third paragraph forward, this section discusses Sudden Pressure relays rather than auto-reclosing schemes, and also addresses BA obligations, inconsistency with PRC-025-1, developments that followed PRC-005 versions 2 or 3, and the 24-year record retention requirements. These issues were supposedly addressed in the SAR for PRC-005-4 dated 2/12/2014. Were they not resolved in version 4?

Document Name:

Likes: 0

Dislikes: 0

Paul Malozewski - Hydro One Networks, Inc. - 3 -

Selected Answer: No

Answer Comment:

The Revised SAR should recognize that definitions would also require revision in order to address the FERC directive in Order 803. We suggest the following addition on Page 4 of the Revised SAR: *"Provide clear, unambiguous requirements, **definitions**, and standard(s)..."*.

Document Name:

Likes: 0

Dislikes: 0

Payam Farahbakhsh - Hydro One Networks, Inc. - 1 -

Selected Answer:

Answer Comment:

Document Name:

Likes: 0

Dislikes: 0

Jason Marshall - ACES Power Marketing - 6 - MRO,WECC,TRE,SERC,SPP,RFC

Error: Subreport could not be shown.

Selected Answer: No

Answer Comment:

(1) First, we are disappointed in NERC's response to the NOPR. We found it to be inappropriately specific in prescribing modifications to the standard. We believe the comments more appropriately would have simply agreed to address the Commission's concerns through the use of the standards development process. We believe NERC's very specific response was inconsistent with the purpose and intent of the standards development process, and that , in essence, NERC's action constitutes developing a standard outside the standards development process. We do note that the careful wording of the Commission directive does not appear to require NERC to implement the changes exactly as NERC proposed in its response. The Commission simply indicated that they find NERC's proposed changes acceptable, but there is no language ordering those changes to be implemented. The Commission directive is to "include supervisory devices," and not to implement NERC's proposed changes. This would be consistent with previous Commission guidance regarding reliability standards directives in which the Commission allows equally efficient and effective alternatives that meet the directive to be used.

(2) We believe a new clean SAR should be issued. The SAR appears to append the inclusion of supervisory relays in a Automatic Reclosing scheme to the previous

SAR which authorized adding sudden pressure relaying to PRC-005. However, the scope of the previous SAR has been completed since the sudden pressure relaying project will be presented to the NERC Board of Trustees for adoption in May.

(3) We are not opposed conceptually to the approach of including important supervising relays in the standard. However, our main concerns are around the process utilized as expressed above.

Document Name:

Likes: 1 Florida Municipal Power Agency, 3,4,5,6, Gowder Chris

Dislikes: 0

Shannon Mickens - Southwest Power Pool, Inc. (RTO) - 2 - SPP

Error: Subreport could not be shown.

Selected Answer: Yes

Answer Comment:

Document Name:

Likes: 0

Dislikes: 0

Chris Gowder - Florida Municipal Power Agency - 3,4,5,6 - FRCC

Selected Answer: No

Answer Comment:

It is FMPPA's opinion that the effort to address the FERC directive in Order No. 803

should be initiated by a new SAR, and not by a revision to an existing SAR, especially one that has been completed. The revised SAR contains a number of artifacts referring to development of PRC-005-4, which as already been adopted by the BOT and filed with FERC. The proposed methodology for addressing the directive states that PRC-005-5 will be used as the starting point for revisions, however, there is no mention of PRC-005-5 in the revised SAR.

The revised SAR states that the “SDT will develop requirement(s)”, but the proposed methodology being presented states that no revisions to Requirements are being proposed. The statement “(t)he SDT may elect to propose revisions to the standard regarding the scope of supervisory devices” is confusing to FMPA since NERC has already told FERC in its NOPR comments what the industry’s position is without consulting the industry through the standard development process. It seems to FMPA that NERC has already determined what standard revisions are to be made, and the SDT does not have any leeway to elect to do anything other than accept the scope of devices proposed by NERC.

FMPA is also confused as to why Balancing Authority has been selected as an applicable functional entity.

Document Name:

Likes: 0

Dislikes: 0

Fuchsia Davis - Bonneville Power Administration - 1,3,5,6 - WECC

Selected Answer: Yes

Answer Comment:

Document Name:

Likes: 0

Dislikes: 0

Shannon Fair - Colorado Springs Utilities - 6 -

Selected Answer: No

Answer Comment:

1. We disagree with the findings of the NERC System Protection and Control Subcommittee technical paper in regards to sudden pressure relays being critical to the Reliability of the BES. Therefore including sudden pressure relays is not meeting the FERC directive in Order No. 803.

Sudden pressure relays, which do trip some transformers, are not important in preventing "instability, cascading, or separation." CSU believes that the inclusion of sudden pressure relays in the NERC Standards will not improve

The reliability of the BES, and are outside the FPA Section 215 jurisdiction. The following are some additional notes on this topic:

• Many transformers are not protected using sudden pressure relays. In fact, due to the sensitivity of sudden pressure relays to vibration, some areas of the country purposefully do not use sudden pressure relays for transformer protection.

• Many transformers that are protected using sudden pressure relays use a guarded trip scheme. For example, in order for the sudden pressure relay to trip the transformer there must also be another condition present such as an over current or differential trip.

• There is not a consistent application of sudden pressure relays in the industry, many transformers do not utilize these relays for protection, and no requirements exist to have sudden pressure relays. CSU believes that including them in a standard will discourage their use and/or encourage those that

currently use them to remove them from their protection scheme. Sudden pressure relays when applied correctly can be an asset in transformer protection, but are not important in preventing “instability, cascading, or separation.

2. We also dis-agree with including a requirement that the BA be required to provide largest unit information. This will happen upon request and does not need a requirement .

Document Name:

Likes: 0

Dislikes: 0

2. The PSTMSDT has proposed revising the definition of “Automatic Reclosing” and “Component Type” to address the FERC directive in Order 803. Do you agree that the proposed revisions to defined terms as shown above address the directive? If not, please provide specific comments regarding the revision and any suggestions for alternatives to address the directive.

Charles Yeung - Southwest Power Pool, Inc. (RTO) - 2 - SPP

Selected Answer:

Answer Comment:

Document Name:

Likes: 0

Dislikes: 0

John Fontenot - Bryan Texas Utilities - 1 -

Selected Answer: Yes

Answer Comment:

Document Name:

Likes: 0

Dislikes: 0

Gul Khan - Oncor Electric Delivery - 1 - TRE

Selected Answer: Yes

Answer Comment:

Document Name:

Likes: 0

Dislikes: 0

Dennis Minton - Florida Keys Electric Cooperative Assoc. - 1 -

Selected Answer:

Answer Comment:

Document Name:

Likes: 0

Dislikes: 0

Amy Casuscelli - Xcel Energy, Inc. - 1,3,5,6 - MRO,WECC,SPP

Selected Answer: Yes

Answer Comment:

Document Name:

Likes: 0

Dislikes: 0

Oliver Burke - Entergy - Entergy Services, Inc. - 1 -

Selected Answer: No

Answer Comment:

Entergy supports comments of the SERC Protection and Control Subcommittee (PCS).

Document Name:

Likes: 0

Dislikes: 0

Thomas Foltz - AEP - 5 -

Selected Answer: No

Answer Comment:

Since there is no universally accepted definition of supervisory relays, simply adding “supervisory relays” as a qualifier to the definition of Automatic Reclosing would not be sufficient, as it is not clear which devices would or would-not be considered a supervisory relay. AEP recommends that clarity be provided as to the exact meaning of “supervisory relay”, as well as the team’s intent in including it, to remove any ambiguity in its potential application. AEP would like to clarify that the inclusion of the supervisory relay function pertains only to those functions which are automatic in nature. The following is what AEP would consider the difference between automatic supervisory relays (which we believe the team wishes to include) and manual supervisory relays (which we believe should be excluded from the proposed definition).

Automatic Supervisory Relay

An automatic supervisory relay uses a combination of one or more signal inputs, as listed below, within a predefined logic to initiate action on a certain component/circuit. Typically, this is done to verify proper operation/function.

- Voltage/Potential
- Current
- Frequency
- Communication signal from another device

Manually Operated Supervisory Relay

A manually operated supervisory relay is a static device that permits an operator/user to initiate action on a certain component/circuit. This can be done both:

•□□□□□□ Locally - Allows local operators/users, on-site, to initiate action on a certain component/circuit.

•□□□□□□ Remotely – Allows remote operators, typically in a dispatch center, to initiate action on a certain component/circuit.

AEP would also like to seek clarity on the maintenance activities applicable to supervisory relays. For example, the testing and calibration of supervisory relays as opposed to simply verifying their operation.

Document Name:

Likes: 0

Dislikes: 0

Emily Rousseau - MRO - 1,2,3,4,5,6 - MRO

Error: Subreport could not be shown.

Selected Answer: Yes

Answer Comment:

Document Name:

Likes: 0

Dislikes: 0

Leonard Kula - Independent Electricity System Operator - 2 -

Selected Answer: Yes

Answer Comment:

Document Name:

Likes: 0

Dislikes: 0

RoLynda Shumpert - SCANA - South Carolina Electric and Gas Co. - 1,3,5,6 - SERC

Selected Answer:

Answer Comment:

Document Name:

Likes: 0

Dislikes: 0

David Jendras - Ameren - Ameren Services - 3 -

Selected Answer: No

Answer Comment:

Related to the third bullet: Please delete 'and Current Sensing' from “Voltage and Current Sensing Devices”. No Automatic Reclosing technologies use Current Sensing because current is not yet flowing. Both the ‘hot vs dead line’ and the ‘synch check’ are voltage functions.

Document Name:

Likes: 0

Dislikes: 0

Michelle D'Antuono - Oxy - Ingleside Cogeneration LP - 5 -

Selected Answer:

Answer Comment:

Document Name:

Likes: 0

Dislikes: 0

Michelle D'Antuono - Oxy - Ingleside Cogeneration LP - 5 -

Selected Answer: Yes

Answer Comment:

ICLP believes the language that has been proposed for the standard is technically accurate and consistent with other NERC Glossary terms. However, we are concerned that it does not directly match that used in the FERC Order. This will not be a problem if the rationale is provided in the initial posting of PRC-005-TBD, and clearly captured in the Supplementary Reference and RSAW. We assume that is the intent – but want to reinforce the reality that any ambiguity will be almost certainly be interpreted in the most all-encompassing manner; even penalizing those who are doing their best to comply with FERC's directives.

Document Name:

Likes: 0

Dislikes: 0

Andrew Pusztai - American Transmission Company, LLC - 1 -

Selected Answer: Yes

Answer Comment:

Document Name:

Likes: 0

Dislikes: 0

Kathleen Black - DTE Energy - 3,4,5 - RFC

Selected Answer: Yes

Answer Comment:

Document Name:

Likes: 0

Dislikes: 0

Pamela Hunter - Southern Company - Southern Company Services, Inc. - 1,3,5,6 - SERC

Error: Subreport could not be shown.

Selected Answer: No

Answer Comment:

a) Related to the third bullet:

1. If it remains note that 'relay' is missing after supervisory in third bullet.
2. Please explain the need for 'Current Sensing Devices since both the 'hot vs dead line' and the 'synch check' are voltage functions.

b) Our specific recommendation is as follows:

1. Make relay potentially plural in the first and forth bullet: 'relay(s)'
2. Remove the third bullet from the SAR language. Note: If it remains, add 'relay' after supervisory
3. Change 'four' to 'three' in bullet sixth bullet.

c) In order to address the voltage inputs to the Supervisory Relays, we recommend a similar approach that was done with the UFLS distributed relays. As such, add a Maintenance Activity associated with the Supervisory Relays to "Verify acceptable measurement of power system input values".

Document Name:

Likes: 0

Dislikes: 0

Rachel Coyne - Texas Reliability Entity, Inc. - 10 -

Selected Answer: Yes

Answer Comment:

Document Name:

Likes: 0

Dislikes: 0

David Kiguel - David Kiguel - 8 -

Selected Answer: No

Answer Comment:

The proposed definition of "Automatic Reclosing" should not be restricted to "Supervisory relay that monitors **BES** quantities ." The definition should be sufficiently general to include all supervisory relays that monitor **electrical quantities** (such as voltage, frequency, or voltage angle). The applicability to Supervisory relays that **monitor BES quantities** should then appear in the PRC-005 standard itself.

Document Name:

Likes: 0

Dislikes: 0

John Merrell - Tacoma Public Utilities (Tacoma, WA) - 1 -

Selected Answer: No

Answer Comment:

Tacoma Power generally supports the revised definitions, but has two comments. First, "Voltage and Current Sensing Devices associated with the supervisory" should be changed to "Voltage and current sensing devices associated with the supervisory relay." Second, clarification will be needed for what is intended by "Control circuitry associated with the...supervisory relay."

Document Name:

Likes: 0

Dislikes: 0

christina bigelow - Electric Reliability Council of Texas, Inc. - 2 -

Selected Answer: Yes

Answer Comment:

ERCOT references and supports the comments provided by the ISO/RTO Standards Review Committee.

Document Name:

Likes: 0

Dislikes: 0

Lee Pedowicz - Northeast Power Coordinating Council - 10 - NPCC

Error: Subreport could not be shown.

Selected Answer: No

Answer Comment:

“Any one of the two specific elements of Sudden Pressure Relaying.” does not appear in the posted PRC-005-3, but it does appear in PRC-005-4, PRC-005-5. Sudden Pressure Relaying should only be capitalized if it is formally defined. It is assumed that the two specific elements of sudden pressure relaying are the actuating device and the associated control wiring.

Document Name:

Likes: 1 Hydro-Qu?bec TransEnergie, 1, Phan Si Truc

Dislikes: 0

Si Truc Phan - Hydro-Qu?bec TransEnergie - 1 - NPCC

Selected Answer: No

Answer Comment: Hydro-Quebec supports comments from RSC-NPCC

Document Name:

Likes: 0

Dislikes: 0

Mike Smith - Manitoba Hydro - 1 -

Selected Answer: Yes

Answer Comment:

Document Name:

Likes: 0

Dislikes: 0

Michael Lowman - Duke Energy - 1,3,5,6 - FRCC,SERC,RFC

Error: Subreport could not be shown.

Selected Answer: No

Answer Comment:

Duke Energy suggests the following revisions to Automatic Reclosing:

A. In bullet 2, replace “BES quantities” with “AC quantities”. We believe that “BES quantities” is undefined, unmeasurable, and vague. We believe this revision clarifies the components that are contained within an Automatic Reclosing scheme. For example, personnel performing the testing would actually be testing and/or verifying AC quantities and not BES quantities. Finally, any BES Element subject to the family of PRC-005 revisions would already be encompassed as part of the Applicability Section.

B. In bullet 3 we suggest changing “associated with the supervisory” with “associated with the supervisory relay” for consistency.

Document Name:

Likes: 0

Dislikes: 0

Dan Bamber - ATCO Electric - 1 - WECC

Selected Answer: No

Answer Comment:

Is the terminology "BES quantities" correctly used here? BES is usually refers to elements such as lines, transformers, etc.

Document Name:

Likes: 0

Dislikes: 0

Randi Heise - Dominion - Dominion Resources, Inc. - 5 -

Error: Subreport could not be shown.

Selected Answer: Yes

Answer Comment:

Minor comment; neither of the links provided in the SAR work (Roster, IERP report).

Document Name:

Likes: 0

Dislikes: 0

Andy Bolivar - NextEra Energy - Florida Power and Light Co. - 1 - FRCC,TRE,NPCC

Selected Answer: Yes

Answer Comment:

Document Name:

Likes: 0

Dislikes: 0

Jeni Renew - SERC Reliability Corporation - 10 - SERC

Error: Subreport could not be shown.

Selected Answer: No

Answer Comment:

1) Related to the third bullet: if "Voltage and Current Sensing Devices" remains, please explain the need for 'Current Sensing Devices' since both the 'hot vs dead line' and the 'synch check' are voltage functions.

The comments expressed herein represent a consensus of the views of the above-named members of the SERC PCS only and should not be construed as the position of SERC Reliability Corporation, its board, or its officers.

Document Name:

Likes: 1 SCANA - South Carolina Electric and Gas Co., 1,3,5,6, Shumpert RoLynda

Dislikes: 0

Molly Devine - IDACORP - Idaho Power Company - 1 -

Selected Answer: Yes

Answer Comment:

Document Name:

Likes: 0

Dislikes: 0

Dennis Chastain - Tennessee Valley Authority - 1,3,5,6 - SERC

Selected Answer: No

Answer Comment:

To our knowledge, current sensing devices cannot be used to supervise reclosing. This needs correcting in the proposed language.

Document Name:

Likes: 0

Dislikes: 0

Paul Malozewski - Hydro One Networks, Inc. - 3 -

Selected Answer: Yes

Answer Comment:

Sudden pressure relays are not included in the NERC Glossary of Terms. We recommend de-capitalizing the term "Sudden Pressure Relays".

Document Name:

Likes: 0

Dislikes: 0

Payam Farahbakhsh - Hydro One Networks, Inc. - 1 -

Selected Answer:

Answer Comment:

Document Name:

Likes: 0

Dislikes: 0

Jason Marshall - ACES Power Marketing - 6 - MRO,WECC,TRE,SERC,SPP,RFC

Error: Subreport could not be shown.

Selected Answer: Yes

Answer Comment:

Document Name:

Likes: 0

Dislikes: 0

Shannon Mickens - Southwest Power Pool, Inc. (RTO) - 2 - SPP

Error: Subreport could not be shown.

Selected Answer: Yes

Answer Comment:

We would suggest to the drafting team to include in the standard a definition for the term 'Supervisory Devices' to make sure that there is no confusion on how this term will be used in reference to Automatic Reclosing Components.

Document Name:

Likes: 0

Dislikes: 0

Chris Gowder - Florida Municipal Power Agency - 3,4,5,6 - FRCC

Selected Answer: Yes

Answer Comment:

FMPA does not agree that the addition of supervisory devices to PRC-005 is necessary to ensure the reliable operation of the Bulk Electric System. However, FMPA recognizes such additions have been directed by FERC, and agrees that the proposed revisions accomplish that goal.

The third bullet under Automatic Reclosing appears to be incomplete, and should have " relay." added to the end.

Document Name:

Likes: 0

Dislikes: 0

Fuchsia Davis - Bonneville Power Administration - 1,3,5,6 - WECC

Selected Answer: Yes

Answer Comment:

Document Name:

Likes: 0

Dislikes: 0

Shannon Fair - Colorado Springs Utilities - 6 -

Selected Answer: Yes

Answer Comment:

Document Name:

Likes: 0

Dislikes: 0

Additional Comments

ISO RTO Council Standards Review Committee

Charles Yeung

1. Do you agree that the scope and objectives of the revised SAR address the directive in Order No. 803? If not, please explain why you do not agree and, if possible, provide specific language revisions that would make it acceptable to you.

Yes

No

Comments:

The SRC is uncertain regarding the meaning of the first bullet shown in the “Detailed Description” section. First, this bullet seems to provide the SDT the ability to modify PRC-005 in perpetuity with the addition of the phrase “...subsequent versions of the standard”. Second, the SRC recommends that any additional directives that would result in revisions to PRC-005 and that are outside Order No. 803 should be subject to a new SAR. This phrase should be deleted from the “Detailed Description”.

1. Consider modifications as needed to address any FERC directives or guidance that may result from the Commission’s consideration of PRC-005-4 or subsequent versions of the standard.
2. The PSTMSDT has proposed revising the definition of “Automatic Reclosing” and “Component Type” to address the FERC directive in Order 803. Do you agree that the proposed revisions to defined terms as shown above address the directive? If not, please provide specific comments regarding the revision and any suggestions for alternatives to address the directive.

Yes

No

Standards Authorization Request Form

When completed, email this form to:

Valerie.Agnew@nerc.net

For questions about this form or for assistance in completing the form, call Valerie Agnew at 404-446-2566.

NERC welcomes suggestions for improving the reliability of the Bulk-Power System through improved Reliability Standards. Please use this form to submit your proposal for a new NERC Reliability Standard or a revision to an existing standard.

Request to propose a new or a revision to a Reliability Standard

Proposed Standard:	PRC-005-6		
Date Submitted:	May 21, 2015		
SAR Requester Information			
Name:	Charles Rogers		
Organization:	Protection System Maintenance Standard Drafting Team		
Telephone:	517-788-0027	E-mail:	Charles.Rogers@cmsenergy.com
SAR Type (Check as many as applicable)			
<input type="checkbox"/>	New Standard	<input type="checkbox"/>	Withdrawal of existing Standard
<input checked="" type="checkbox"/>	Revision to existing Standard	<input type="checkbox"/>	Urgent Action

SAR Information
Industry Need (What is the industry problem this request is trying to solve?):
In Order No. 803, FERC approved Standard PRC-005-3 and, in Paragraph 31, directed that: "...pursuant to section 215(d)(5) of the FPA, NERC develop modifications to PRC-005-3 to include supervisory devices associated with auto-reclosing relay schemes to which the Reliability Standard applies. Further, we clarify that NERC’s proposal regarding the scope of supervisory devices is an acceptable approach to satisfy the Commission directive. Specifically, NERC proposed in its NOPR comments, and we find acceptable, that the scope of the supervisory devices to be encompassed in the Reliability Standard are those providing voltage supervision, supervisory inputs associated with selective auto-reclosing, and sync-check relays that are part of a reclosing scheme covered by PRC-005-3."

SAR Information
Purpose or Goal (How does this request propose to address the problem described above?):
The SDT shall consider modifications, as needed, to address the FERC directive contained in Order 803 resulting from the Commission’s consideration of PRC-005-3. The Supplementary Reference Document (provided as a technical reference for PRC-005-3) should also be modified to provide the rationale for the maintenance activities and intervals within the revised standard, as well as to provide application guidance to industry.
Identify the Objectives of the proposed standard’s requirements (What specific reliability deliverables are required to achieve the goal?):
Provide clear, unambiguous requirements, standard specific definitions standard(s), and advisory guidance to address the directives in FERC Order 803.
Brief Description (Provide a paragraph that describes the scope of this standard action.)
The Standard Drafting Team (SDT) shall modify NERC Standard PRC-005-3 to explicitly address the directive in Order 803. The SDT shall also consider changes to the standard and supporting documents that provide consistency and alignment with other Reliability Standards.

SAR Information

Detailed Description (Provide a description of the proposed project with sufficient details for the standard drafting team to execute the SAR. Also provide a justification for the development or revision of the standard, including an assessment of the reliability and market interface impacts of implementing or not implementing the standard action.)

The SDTs execution of this SAR requires the SDT to address the directive in FERC Order 803. The SDT will develop requirement(s) to include supervisory devices associated with automatic reclosing relay schemes to which the Reliability Standard applies. The SDT may elect to propose revisions to the standard regarding the scope of supervisory devices as an acceptable approach to satisfy the Commission directive, as proposed in the NOPR comments submitted by NERC. Specifically, NERC proposed that the scope of the supervisory devices to be encompassed in the Reliability Standard are those providing voltage supervision, supervisory inputs associated with selective automatic reclosing, and synchronism check relays that are part of a reclosing scheme covered by PRC-005-3.

The SDT shall also:

1. Revise the Implementation Plans for PRC-002i, PRC-005-2ii, PRC-005-3, PRC-005-3i, PRC-005-3ii, PRC-005-4 and PRC-005-5 as needed to facilitate consistent and systematic implementation.
2. Modify the informative Supplementary Reference Document (provided as a technical reference for PRC-005-3) as necessary to provide application guidance to industry.

Reliability Functions

The Standard will Apply to the Following Functions (Check each one that applies.)

<input type="checkbox"/> Regional Reliability Organization	Conducts the regional activities related to planning and operations, and coordinates activities of Responsible Entities to secure the reliability of the Bulk Electric System within the region and adjacent regions.
<input type="checkbox"/> Reliability Coordinator	Responsible for the real-time operating reliability of its Reliability Coordinator Area in coordination with its neighboring Reliability Coordinator’s wide area view.

Reliability Functions	
<input checked="" type="checkbox"/> Balancing Authority	Integrates resource plans ahead of time, and maintains load-interchange-resource balance within a Balancing Authority Area and supports Interconnection frequency in real time.
<input type="checkbox"/> Interchange Authority	Ensures communication of interchange transactions for reliability evaluation purposes and coordinates implementation of valid and balanced interchange schedules between Balancing Authority Areas.
<input type="checkbox"/> Planning Coordinator	Assesses the longer-term reliability of its Planning Coordinator Area.
<input type="checkbox"/> Resource Planner	Develops a >one year plan for the resource adequacy of its specific loads within a Planning Coordinator area.
<input type="checkbox"/> Transmission Planner	Develops a >one year plan for the reliability of the interconnected Bulk Electric System within its portion of the Planning Coordinator area.
<input type="checkbox"/> Transmission Service Provider	Administers the transmission tariff and provides transmission services under applicable transmission service agreements (e.g., the pro forma tariff).
<input checked="" type="checkbox"/> Transmission Owner	Owns and maintains transmission facilities.
<input type="checkbox"/> Transmission Operator	Ensures the real-time operating reliability of the transmission assets within a Transmission Operator Area.
<input checked="" type="checkbox"/> Distribution Provider	Delivers electrical energy to the End-use customer.
<input checked="" type="checkbox"/> Generator Owner	Owns and maintains generation facilities.
<input type="checkbox"/> Generator Operator	Operates generation unit(s) to provide real and reactive power.
The Standard will Apply to the Following Functions (Check each one that applies.)	
<input type="checkbox"/> Purchasing-Selling Entity	Purchases or sells energy, capacity, and necessary reliability-related services as required.
<input type="checkbox"/> Market Operator	Interface point for reliability functions with commercial functions.
<input type="checkbox"/> Load-Serving Entity	Secures energy and transmission service (and reliability-related services) to serve the End-use Customer.

Reliability and Market Interface Principles

Applicable Reliability Principles (Check all that apply).	
<input checked="" type="checkbox"/>	1. Interconnected bulk power systems shall be planned and operated in a coordinated manner to perform reliably under normal and abnormal conditions as defined in the NERC Standards.
<input type="checkbox"/>	2. The frequency and voltage of interconnected bulk power systems shall be controlled within defined limits through the balancing of real and reactive power supply and demand.
<input type="checkbox"/>	3. Information necessary for the planning and operation of interconnected bulk power systems shall be made available to those entities responsible for planning and operating the systems reliably.
<input type="checkbox"/>	4. Plans for emergency operation and system restoration of interconnected bulk power systems shall be developed, coordinated, maintained and implemented.
<input checked="" type="checkbox"/>	5. Facilities for communication, monitoring and control shall be provided, used and maintained for the reliability of interconnected bulk power systems.
<input type="checkbox"/>	6. Personnel responsible for planning and operating interconnected bulk power systems shall be trained, qualified, and have the responsibility and authority to implement actions.
<input type="checkbox"/>	7. The security of the interconnected bulk power systems shall be assessed, monitored and maintained on a wide area basis.
<input type="checkbox"/>	8. Bulk power systems shall be protected from malicious physical or cyber attacks.
Does the proposed Standard comply with all of the following Market Interface Principles?	
1. A reliability standard shall not give any market participant an unfair competitive advantage.	Enter (yes/no) Yes
2. A reliability standard shall neither mandate nor prohibit any specific market structure.	Enter (yes/no) Yes
Does the proposed Standard comply with all of the following Market Interface Principles?	
3. A reliability standard shall not preclude market solutions to achieving compliance with that standard.	Enter (yes/no) Yes
4. A reliability standard shall not require the public disclosure of commercially sensitive information. All market participants shall have equal opportunity to access commercially non-sensitive information that is required for compliance with reliability standards.	Enter (yes/no) Yes

Related Standards	
Standard No.	Explanation

Related SARs	
SAR ID	Explanation

Regional Variances	
Region	Explanation
ERCOT	
FRCC	
MRO	
NPCC	
RFC	
SERC	
SPP	
WECC	

Implementation Plan

Project 2007-17.4 PRC-005 FERC Order No. 803 Directive
PRC-005-6

Standards Involved

Approval:

- PRC-005-6 – Protection System, Automatic Reclosing, and Sudden Pressure Relaying Maintenance

Retirement:

- PRC-005-5 – Protection System, Automatic Reclosing, and Sudden Pressure Relaying Maintenance
- PRC-005-4 Protection System, Automatic Reclosing, and Sudden Pressure Relaying Maintenance
- PRC-005-3 (ii) Protection System and Automatic Reclosing Maintenance
- PRC-005-3 (i) Protection System and Automatic Reclosing Maintenance
- PRC-005-3 Protection System and Automatic Reclosing Maintenance
- PRC-005-2 (ii) Protection System Maintenance
- PRC-005-2 (i) Protection System Maintenance
- PRC-005-2 Protection System Maintenance
- PRC-005-1b – Transmission and Generation Protection System Maintenance and Testing
- PRC-008-0 – Implementation and Documentation of Underfrequency Load Shedding Equipment Maintenance Program
- PRC-011-0 – Undervoltage Load Shedding System Maintenance and Testing
- PRC-017-0 – Special Protection System Maintenance and Testing

Prerequisite Approvals:

N/A

Background:

In Order No. 803, FERC approved Standard PRC-005-3 and, in Paragraph 31, directed NERC to:

"...develop modifications to PRC-005-3 to include supervisory devices associated with auto-reclosing relay schemes to which the Reliability Standard applies. Further, we clarify that NERC's proposal regarding the scope of supervisory devices is an acceptable approach to satisfy the Commission directive. Specifically, NERC proposed in its NOPR comments, and we find acceptable, that the scope of the supervisory devices to be encompassed in the Reliability Standard are those providing voltage supervision, supervisory inputs associated with selective auto-reclosing, and sync-check relays that are part of a reclosing scheme covered by PRC-005-3."

This Implementation Plan adds:

- The implementation of changes relating to maintenance and testing of supervisory relays and associated voltage sensing devices related to Automatic Reclosing.
- The phased implementation approach included in the approved PRC-005-2 and proposed PRC-005-2(i) will remain as-is.
- This implementation schedule lays out the implementation timeline for the currently effective PRC-005-2 and proposed PRC-005-2(i), and combines the implementation plans for the approved PRC-005-3 and all subsequent pending PRC-005 versions (PRC-005-2(ii), PRC-005-3(i), PRC-005-3(ii), PRC-005-4 and PRC-005-5), making all versions from PRC-005-3 onwards effective on the same day PRC-005-6 becomes effective. The effective dates for the various phases specified in PRC-005-3 and each subsequent version of PRC-005 will align with the effective dates for those phases included in the PRC-005-6 Implementation Plan. For the pending versions that do not entail phased implementation, the versions will become effective on the date PRC-005-6 first becomes effective.
- Notwithstanding any order to the contrary, PRC-005-2(ii), PRC-005-3, PRC-005-3(i), PRC-005-3(ii), PRC-005-4 and PRC-005-5 will not become effective, and PRC-005-2 will remain in effect and not be retired until the effective date of the PRC-005-6 standard under this implementation plan.¹

The Implementation Plan reflects consideration of the following:

1. The requirements set forth in the proposed standard, which carry forward requirements from PRC-005-2, PRC-005-2(i), PRC-005-2(ii), PRC-005-3, PRC-005-3(i), PRC-005-3(ii), PRC-005-4 and PRC-005-5, establish minimum maintenance activities for Protection System, Automatic Reclosing, and Sudden Pressure Relaying Component Types as well as the maximum allowable maintenance intervals for these maintenance activities.

¹ In jurisdictions where previous versions of PRC-005 have not yet become effective according to their implementation plans (even if approved by order), this implementation plan and the PRC-005-6 standard supersedes and replaces the implementation plans and standards for PRC-005-2(i), PRC-005-2(ii), PRC-005-3, PRC-005-3(i), PRC-005-3(ii), PRC-005-4, and PRC-005-5.

2. The maintenance activities established in the various PRC-005 versions may not be presently performed by some registered entities and the established maximum allowable intervals may be shorter than those currently in use by some entities. Therefore, registered entities may not be presently performing a maintenance activity or may be using longer intervals than the maximum allowable intervals established in the PRC-005 standards. For these registered entities, it is unrealistic to become immediately compliant with the new activities or intervals. Further, registered entities should be allowed to become compliant in such a way as to facilitate a continuing PRC-005 maintenance program. The registered entities that have previously been performing maintenance within the newly specified intervals may not have all the documentation needed to demonstrate compliance with all of the maintenance activities specified.
3. The implementation schedule set forth below carries forward the implementation schedules contained in PRC-005-2 and proposed PRC-005-2(i), and combines the implementation schedules for PRC-005-2(ii), PRC-005-3, PRC-005-3(i), PRC-005-3(ii), PRC-005-4 and PRC-005-5. In addition, the implementation schedule includes changes needed to address the addition of Automatic Reclosing supervisory relays and associated voltage sensing devices in PRC-005-6.

General Considerations:

Each Transmission Owner, Generator Owner, and Distribution Provider shall maintain documentation to demonstrate compliance with PRC-005-1b, PRC-008-0, PRC-011-0, and PRC-017-0 until that entity meets all of the requirements of the effective PRC-005-2, or its combined successor standards, in accordance with this implementation plan.

While registered entities are implementing the requirements of PRC-005-2 or its combined successor standards, each registered entity must be prepared to identify:

- All of its applicable Protection System, Automatic Reclosing, and Sudden Pressure Relaying Components, and
- Whether each component has last been maintained according to PRC-005-2 (or its combined successor standards), PRC-005-1b, PRC-008-0, PRC-011-0, PRC-017-0, or a combination thereof.

Effective Date

PRC-005-6 shall become effective on the first day of the first calendar quarter after the date that the standard is approved by an applicable governmental authority or as otherwise provided for in a jurisdiction where approval by an applicable governmental authority is required for a standard to go into effect. Where approval by an applicable governmental authority is not required, the standard shall become effective on the first day of the first calendar quarter after the date the standard is adopted by the NERC Board of Trustees or as otherwise provided for in that jurisdiction.

Retirement of Existing Standards:

Standards PRC-005-1b, PRC-008-0, PRC-011-0, and PRC-017-0 shall remain active throughout the phased implementation period of PRC-005-2 and shall be applicable to a registered entity's Protection System Component maintenance activities not yet transitioned to PRC-005-2. Standards PRC-005-1b, PRC-008-0, PRC-011-0, and PRC-017-0 shall be retired at midnight of March 31, 2027 or as otherwise made effective pursuant to the laws applicable to such Electric Reliability Organization (ERO) governmental authorities; or, in those jurisdictions where no regulatory approval is required, at midnight of March 31, 2027.

PRC-005-2 and PRC-005-2(i) shall be retired at midnight of the day immediately prior to the first day of the first calendar quarter, twelve (12) calendar months following applicable regulatory approval of PRC-005-6, or as otherwise made effective pursuant to the laws applicable to such ERO governmental authorities; or, in those jurisdictions where no regulatory approval is required, the first day of the first calendar quarter from the date of Board of Trustees' adoption.

If approved by FERC prior to the approval of PRC-005-6, PRC-005-2(ii), PRC-005-3, PRC-005-3(i), PRC-005-3(ii), PRC-005-4 and PRC-005-5 shall be retired on the date immediately prior to the first day of the first calendar quarter following regulatory approval of PRC-005-6.

Implementation Plan for Definitions:

This section includes all newly defined or revised terms used in the proposed standard. Terms already defined in the Reliability Standards Glossary of Terms (Glossary) are not repeated here. New or revised definitions listed below become approved when the proposed standard is approved. When the standard becomes effective, the Glossary definition will be removed from the individual standard and added to the Glossary. The definitions of terms used only in the standard will remain in the standard.

Glossary Definition:

- None

Definitions of Terms Used in the Standard:

Automatic Reclosing – Includes the following Components:

- Reclosing relay
- Supervisory relay(s) – relay(s) that perform voltage and/or sync check functions that enable or disable operation of the reclosing relay
- Voltage sensing devices associated with the supervisory relay(s)
- Control circuitry associated with the reclosing relay or supervisory relay(s)

Component Type –

- Any one of the five specific elements of a Protection System.

- Any one of the four specific elements of Automatic Reclosing.
- Any one of the two specific elements of Sudden Pressure Relaying.

Component – Any individual discrete piece of equipment included in a Protection System, Automatic Reclosing, or Sudden Pressure Relaying.

Countable Event – A failure of a Component requiring repair or replacement, any condition discovered during the maintenance activities in Tables 1-1 through 1-5, Table 3, Tables 4-1 through 4-3, and Table 5, which requires corrective action or a Protection System Misoperation attributed to hardware failure or calibration failure. Misoperations due to product design errors, software errors, relay settings different from specified settings, Protection System Component, Automatic Reclosing, or Sudden Pressure Relaying configuration or application errors are not included in Countable Events.

Implementation Plan for New or Revised Definitions:

The revised definitions (Automatic Reclosing, Component, and Countable Event) become effective upon the effective date of PRC-005-6.

Implementation Plan for PRC-005-2 and PRC-005-6

Requirements R1, R2, and R5:

PRC-005-2: For Protection System Components, entities shall be 100% compliant on April 1, 2015 or, in those jurisdictions where no regulatory approval is required, on January 1, 2015 or as otherwise made effective pursuant to the laws applicable to such ERO governmental authorities.

PRC-005-6: For Automatic Reclosing Components, Sudden Pressure Relaying Components, and Dispersed Generation Resources, entities shall be 100% compliant on the first day of the first calendar quarter twelve (12) months following applicable regulatory approvals of PRC-005-6 or, in those jurisdictions where no regulatory approval is required, on the first day of the first calendar quarter twenty-four (24) months following NERC Board of Trustees' adoption of PRC-005-6 or as otherwise made effective pursuant to the laws applicable to such ERO governmental authorities.

Implementation Plan for Requirements R3 and R4:

PRC-005-2:

1. For Protection System Component maintenance activities with maximum allowable intervals of less than one (1) calendar year, as established in Tables 1-1 through 1-5:
 - The entity shall be 100% compliant on October 1, 2015, or in those jurisdictions where no regulatory approval is required, on July 1, 2016, or as otherwise made effective pursuant to the laws applicable to such ERO governmental authorities.

2. For Protection System Component maintenance activities with maximum allowable intervals one (1) calendar year or more, but two (2) calendar years or less, as established in Tables 1-1 through 1-5:
 - The entity shall be 100% compliant on April 1, 2017 or, in those jurisdictions where no regulatory approval is required, on January 1, 2017 or as otherwise made effective pursuant to the laws applicable to such ERO governmental authorities.
3. For Protection System Component maintenance activities with maximum allowable intervals of three (3) calendar years, as established in Tables 1-1 through 1-5:
 - The entity shall be at least 30% compliant on April 1, 2016 (or, for generating plants with scheduled outage intervals exceeding two years, at the conclusion of the first succeeding maintenance outage) or, in those jurisdictions where no regulatory approval is required, on January 1, 2016 or as otherwise made effective pursuant to the laws applicable to such ERO governmental authorities.
 - The entity shall be at least 60% compliant on April 1, 2017 or, in those jurisdictions where no regulatory approval is required, on January 1, 2017 or as otherwise made effective pursuant to the laws applicable to such ERO governmental authorities.
 - The entity shall be 100% compliant on April 1, 2018 or, in those jurisdictions where no regulatory approval is required, on January 1, 2018 or as otherwise made effective pursuant to the laws applicable to such ERO governmental authorities.
4. For Protection System Component maintenance activities with maximum allowable intervals of six (6) calendar years, as established in Tables 1-1 through 1-5 and Table 3:
 - The entity shall be at least 30% compliant on April 1, 2017 (or, for generating plants with scheduled outage intervals exceeding three years, at the conclusion of the first succeeding maintenance outage) or, in those jurisdictions where no regulatory approval is required, on January 1, 2017 or as otherwise made effective pursuant to the laws applicable to such ERO governmental authorities.
 - The entity shall be at least 60% compliant on April 1, 2019 or, in those jurisdictions where no regulatory approval is required, on January 1, 2019 or as otherwise made effective pursuant to the laws applicable to such ERO governmental authorities.
 - The entity shall be 100% compliant on April 1, 2021 or, in those jurisdictions where no regulatory approval is required, on January 1, 2021 or as otherwise made effective pursuant to the laws applicable to such ERO governmental authorities.
5. For Protection System Component maintenance activities with maximum allowable intervals of twelve (12) calendar years, as established in Tables 1-1 through 1-5, Table 2, and Table 3:

- The entity shall be at least 30% compliant on April 1, 2019 or, in those jurisdictions where no regulatory approval is required, on January 1, 2019 or as otherwise made effective pursuant to the laws applicable to such ERO governmental authorities.
- The entity shall be at least 60% compliant on April 1, 2023 or, in those jurisdictions where no regulatory approval is required, on January 1, 2023 or as otherwise made effective pursuant to the laws applicable to such ERO governmental authorities.
- The entity shall be 100% compliant on April 1, 2027 or, in those jurisdictions where no regulatory approval is required, on January 1, 2027 or as otherwise made effective pursuant to the laws applicable to such ERO governmental authorities.

PRC-005-6:

1. For Automatic Reclosing Components, Sudden Pressure Relaying Components, and Dispersed Generation Resources maintenance activities with maximum allowable intervals of six (6) calendar years, as established in Table 4-1, 4-2(a) and 4-2(b):
 - The entity shall be at least 30% compliant on the first day of the first calendar quarter thirty-six (36) months following applicable regulatory approval of PRC-005-6 (or, for generating plants with scheduled outage intervals exceeding three years, at the conclusion of the first succeeding maintenance outage) or, in those jurisdictions where no regulatory approval is required, on the first day of the first calendar quarter forty-eight (48) months following NERC Board of Trustees' adoption of PRC-005-6 or as otherwise made effective pursuant to the laws applicable to such ERO governmental authorities.
 - The entity shall be at least 60% compliant on the first day of the first calendar quarter sixty (60) months following applicable regulatory approval of PRC-005-6 or, in those jurisdictions where no regulatory approval is required, on the first day of the first calendar quarter seventy-two (72) months following NERC Board of Trustees' adoption of PRC-005-6, or as otherwise made effective pursuant to the laws applicable to such ERO governmental authorities.
 - The entity shall be 100% compliant on the first day of the first calendar quarter eighty-four (84) months following applicable regulatory approval of PRC-005-6 or, in those jurisdictions where no regulatory approval is required, on the first day of the first calendar quarter ninety-six (96) months following NERC Board of Trustees' adoption of PRC-005-6 or as otherwise made effective pursuant to the laws applicable to such ERO governmental authorities.
2. For Automatic Reclosing Components, Sudden Pressure Relaying Components, and Dispersed Generation Resources maintenance activities, with maximum allowable intervals of twelve (12) calendar years, as established in Table 4-1, 4.2(a), or 4.2(b):
 - The entity shall be at least 30% compliant on the first day of the first calendar quarter sixty (60) months following applicable regulatory approval of PRC-005-6 or, in those jurisdictions where no regulatory approval is required, on the first day of the first calendar quarter seventy-two

(72) months following NERC Board of Trustees' adoption of PRC-005-6 or as otherwise made effective pursuant to the laws applicable to such ERO governmental authorities.

- The entity shall be at least 60% compliant on the first day of the first calendar quarter following one hundred eight (108) months following applicable regulatory approval of PRC-005-6 or, in those jurisdictions where no regulatory approval is required, on the first day of the first calendar quarter one hundred twenty (120) months following NERC Board of Trustees' adoption of PRC-005-6 or as otherwise made effective pursuant to the laws applicable to such ERO governmental authorities.
- The entity shall be 100% compliant on the first day of the first calendar quarter one hundred fifty-six (156) months following applicable regulatory approval of PRC-005-6 or, in those jurisdictions where no regulatory approval is required, on the first day of the first calendar quarter one hundred sixty-eight (168) months following NERC Board of Trustees' adoption of PRC-005-6 or as otherwise made effective pursuant to the laws applicable to such ERO governmental authorities.

Applicability:

This standard applies to the following functional entities:

- Transmission Owner
- Generator Owner
- Distribution Provider

Alignment of PRC-005 Compliance Dates

I. PRC-005 Compliance Issue and Proposal to Align Compliance Dates

Since the approval of PRC-005-2, which is currently mandatory and enforceable, a number of standards development projects have resulted in either including or excluding devices from the scope of PRC-005. Currently, there are eight approved or currently proposed PRC-005 versions, and each Version comes with a separate implementation schedule. Depending on the type of device and specific requirement in some of the PRC-005 versions, the implementation is divided into phases, requiring registered entities to gradually ensure compliance of a percentage of their devices until they reach 100% compliance.

Versions -3, -4, and -6 will require three consecutive updates to the registered entities' Protection System Maintenance Programs (PSMP), which is expected to be a time-consuming task for many. Based on the implementation plans for these three Versions, the required PSMP updates would have to be completed within a year to 18 months. According to the PRC-005 drafting team, which represents various industry members, this short period of time for review and identification of all assets subject to the revised PRC-005 Versions could lead to errors and misidentification of devices. Further, the existence of eight implementation plans could lead to misinterpretations and inconsistencies in the compliance and auditing practices throughout the ERO Enterprise.

To address this compliance issue, the PRC-005 drafting team requested that NERC align the effective dates of all outstanding PRC-005 Versions, thus simplifying the implementation schedule for this Reliability Standard. In response to the drafting team's request, NERC plans to petition the Federal Energy Regulatory Commission (FERC) to delay the implementation of PRC-005-3 and have PRC-005-2(ii), PRC-005-3, PRC-005-3(i), PRC-005-3(ii), PRC-005-4, PRC-005-5, and PRC-005-6 all become effective on the same date. NERC is also proposing that the implementation of PRC-005-2(i) is aligned with the currently effective PRC-005-2. The phased implementation approach will remain but the effective dates for each phase will align across all applicable Versions.

This proposal is reflected in the implementation plan for PRC-005-6. If supported by industry members, the implementation plan will be included in the PRC-005-6 petition to be filed with FERC for review.

II. PRC-005 Versions Overview

The draft PRC-005-6 incorporates all revisions made to PRC-005-2 as a result of the development of PRC-005-2(i), PRC-005-2(ii), PRC-005-3, PRC-005-3(i), PRC-005-3(ii), PRC-005-4, and PRC-005-5, and PRC-005-6. Version 3 added Automatic Reclosing devices; Versions 2(i), 3(i), and -5 exclude individual dispersed generation resources from the applicability of the Standard; Versions 2(ii) and 3(ii) replace the term "Special Protection System" with the term "Remedial Action Scheme"; Version 4 added Sudden Pressure Relays; and Version 6 will add supervisory relays and exclude individual dispersed generation resources from the applicability of this Reliability Standard.

From this list of all PRC-005 Versions, Version 3 is approved by FERC; PRC-005-2(i), PRC-005-2(ii), PRC-005-3(i), PRC-005-3(ii), and PRC-005-4 are pending regulatory approval; PRC-005-5 has not yet been filed for approval with FERC; and PRC-005-6 is currently under development.

III. Impact on the Reliability of the Bulk Power System and on Compliance with PRC-005

Based on the implementation schedule for the FERC-approved PRC-005-3 and estimated approval and effective dates for the remaining Versions, the delay in the implementation of PRC-005-3 created by this proposal is anticipated to be approximately one year.

The proposed changes described here and in the proposed PRC-005-6 implementation plan will not affect the immediate implementation of Versions 2(i), 3(i), and -5. These Versions exclude certain dispersed generation resources from the definition of Bulk Electric System, and from the applicability of PRC-005. Thus, registered entities that own and operate dispersed generation resources will remain unaffected by the proposed changes.

PRC-005-2(ii) and PRC-005-3(ii) reflect enhancements to the NERC Glossary of Terms related to Special Protection Systems and Remedial Action Schemes. While alignment between the standards and the Glossary of Terms is important, potential delays in this alignment would not present a risk to the reliability of the BPS. The petition requesting changes to PRC-005-2(ii) and PRC-005-3(ii) is pending and its review will likely be delayed until the Commission reviews the petition for PRC-010-1 related to Under-Voltage Load Shedding Program. Finally, the anticipated changes related to Remedial Action Schemes are minor in nature and are unlikely to introduce an actual reliability risk.

Because the Automatic Reclosing devices and Sudden Pressure Relays brought in by Versions -3 and -4 are limited in scope, a potential delay in the implementation of these Versions of PRC-005 is also unlikely to increase risk to the BPS. Many of these devices are already monitored by industry in anticipation of the upcoming compliance requirements, but may not be specifically included in the registered entities' PSMPs at this time.

IV. Benefits to Registered Entities

The proposal aims to simplify the compliance efforts of all registered entities subject to PRC-005 and give industry additional time to comply with Versions -3, -4, and -6, which require PSMP updates. Having PRC-005-2(ii), PRC-005-3, PRC-005-3(i), PRC-005-3(ii), PRC-005-4, and PRC-005-5, PRC-005-6 become effective at the same time minimizes the possibility of misinterpretations of each Version and associated compliance obligations, thus limiting the compliance risk for registered entities. In addition, the proposed changes will not affect the anticipated exclusion of certain dispersed generation resources from the applicability of the standard.

To further facilitate compliance, NERC plans to use the additional time until PRC-005-6 becomes effective to conduct outreach and provide training to ensure that registered entities are well aware and prepared to meet their obligations under the various PRC-005 Versions.

Effective Date Information

Table 1 provides information regarding each version of the PRC-005 standard.

Table 1: PRC-005 Effective Date Information		
Standard	Effective Date¹	Comments
PRC-005-2	April 1, 2015	
PRC-005-2(i)	May 29, 2015	Proposed effective with version 2, which will be immediately following FERC Approval.
PRC-005-2(ii)	Filed and Pending Regulatory Approval	Proposed to be deferred until version 6 effective date. ²
PRC-005-3	April 1, 2016	Proposed to be deferred until version 6 effective date.
PRC-005-3(i)	April 1, 2016	Proposed to be deferred until version 6 effective date.
PRC-005-3(ii)	Filed and Pending Regulatory Approval	Proposed to be deferred until version 6 effective date.
PRC-005-4	Filed and Pending Regulatory Approval	Proposed to be deferred until version 6 effective date.
PRC-005-5	Pending Regulatory Filing	Proposed to be deferred until version 6 effective date.
PRC-005-6	Pending Regulatory Filing	TBD

¹ The effective date listed is the start date of when the standard becomes effective. This does not include the phased in approach.

² This is based on when FERC approves PRC-005-6, which could be from three (3) months to one (1) year.

Unofficial Comment Form

Project 2007-17.4 PRC-005 Order No. 803 Directive Standard Authorization Request

DO NOT use this form for submitting comments. Use the [electronic form](#) to submit comments on the Standard Authorization Request (SAR) by **8:00 p.m. Eastern, July 10, 2015**.

Documents and information about this project are available on the [project page](#). If you have questions contact Senior Standards Developer, [Stephen Crutchfield](#) (via email) or at (609) 651-9455.

Background Information

In Order No. 803, FERC approved Standard PRC-005-3 and, in Paragraph 31, directed NERC to:

"...direct that, pursuant to section 215(d)(5) of the FPA, NERC develop modifications to PRC-005-3 to include supervisory devices associated with auto-reclosing relay schemes to which the Reliability Standard applies. Further, we clarify that NERC's proposal regarding the scope of supervisory devices is an acceptable approach to satisfy the Commission directive. Specifically, NERC proposed in its NOPR comments, and we find acceptable, that the scope of the supervisory devices to be encompassed in the Reliability Standard are those providing voltage supervision, supervisory inputs associated with selective auto-reclosing, and sync-check relays that are part of a reclosing scheme covered by PRC-005-3."

The Protection System Maintenance and Testing Standard Drafting Team (PSMTSDT) proposed revision of the standard specific defined terms "Automatic Reclosing" and "Component Type" as follows:

Automatic Reclosing – Includes the following Components:

- Reclosing relay
- **Supervisory relay(s) – relay(s) that perform voltage and/or sync check functions that enables or disables operation of the reclosing relay**
- **Voltage sensing devices associated with the supervisory relay(s)**
- Control circuitry associated with the reclosing relay **or supervisory relay(s)**

Component Type –

- Any one of the five specific elements of a Protection System.
- Any one of the ~~two~~**four** specific elements of Automatic Reclosing.
- Any one of the two specific elements of Sudden Pressure Relaying.

The Rationales for “Automatic Relaying” and “Component Type” were also revised to reflect the proposed revisions to the defined terms above. Tables 4-1 and 4-2 were updated by adding “supervisory relay(s)” as appropriate. A new Table 4-3 was added to address maintenance activities and intervals for Automatic Reclosing with supervisory relays. No substantive revisions are being proposed for the Requirements of the standard. The only revisions to Requirements R1 and R3 included updating the Table numbering to reflect the addition of Table 4-3. The VSLs were updated to reflect the Requirement language for R1 and R3. All references to table numbering throughout the standard have also been corrected to reflect the addition of Table 4-3. This version of PRC-005 used PRC-005-5 developed under Project 2014-01 as the starting point for revisions to address the directive.

The PSMTSDT has proposed combining the Implementation Plans for previous versions of PRC-005 (including PRC-005-3, PRC-005-3i, PRC-005-3ii, PRC-005-4 and PRC-005-5). The team believes that the proposed Implementation Plan for PRC-005-6 alleviates the burden of multiple revisions of the Protection System Maintenance Program (PSMP) by aligning the effective dates of all of these version of PRC-005 while minimizing risk to the Bulk Electric System.

You do not have to answer all questions below. Due to the expected volume of comments, the PSMTSDT asks that commenters consider consolidating responses and endorsing comments provided by another.

Questions

1. Do you agree that the scope and objectives of the SAR address the directive in Order No. 803? If not, please explain why you do not agree and, if possible, provide specific language revisions that would make it acceptable to you.

Yes

No

Comments:

2. The PSMTSDT has proposed revising the definition of “Automatic Reclosing” and “Component Type” to address the FERC directive in Order 803. Do you agree that the proposed revised definitions? If not, please provide specific comments regarding the revision and any suggestions for alternatives to address the directive.

Yes

No

Comments:

3. The PSMTSDT has added Table 4-3 to address maintenance activities and intervals for voltage sensing devices associated with supervisory relays. Do you agree with the proposed table? If not, please provide specific comments regarding the table and any suggestions for alternative language.

Yes

No

Comments:

4. The PSMTSDT has made revisions to the Supplementary Reference and FAQ Document. Do you agree with the proposed revisions? If not, please provide specific comments regarding the revisions and any suggestions for alternative language.

Yes

No

Comments:

5. The PSMTSDT has proposed combining the Implementation Plans for previous versions of PRC-005 (including PRC-005-3, PRC-005-3i, PRC-005-3ii, PRC-005-4 and PRC-005-5). Do you agree with the proposed Implementation Plan? If not, please provide specific comments regarding the Implementation Plan and any suggestions for alternative language.

Yes

No

Comments:

Standard Development Timeline

This section is maintained by the drafting team during the development of the standard and will be removed when the standard becomes effective.

Development Steps Completed

1. SAR posted for comment March 12 – April 10, 2015.

Description of Current Draft

This version of PRC-005 is posted for a 45-day concurrent comment and ballot period to address directives from [FERC Order No. 803](#), addressing Automatic Reclosing. Specifically, supervisory relays, associated voltage sensing devices, and associated control circuitry were added.

Anticipated Actions	Anticipated Dates
45-day Formal Comment Period with Parallel Ballot	May 2015 – July 2015
Final ballot	July 2015
BOT adoption	August 2015

Definitions of Terms Used in Standard

This section includes all newly defined or revised terms used in the proposed standard. Terms already defined in the Reliability Standards Glossary of Terms (Glossary) are not repeated here. New or revised definitions listed below become approved when the proposed standard is approved. When the standard becomes effective, this defined term will be removed from the individual standard and added to the Glossary.

Automatic Reclosing (see Section 6 of the Standard)

A. Introduction

1. **Title:** Protection System, Automatic Reclosing, and Sudden Pressure Relaying Maintenance
2. **Number:** PRC-005-6
3. **Purpose:** To document and implement programs for the maintenance of all Protection Systems, Automatic Reclosing, and Sudden Pressure Relaying affecting the reliability of the Bulk Electric System (BES) so that they are kept in working order.
4. **Applicability:**
 - 4.1. **Functional Entities:**
 - 4.1.1 Transmission Owner
 - 4.1.2 Generator Owner
 - 4.1.3 Distribution Provider
 - 4.2. **Facilities:**
 - 4.2.1 Protection Systems and Sudden Pressure Relaying that are installed for the purpose of detecting Faults on BES Elements (lines, buses, transformers, etc.)
 - 4.2.2 Protection Systems used for underfrequency load-shedding systems installed per ERO underfrequency load-shedding requirements.
 - 4.2.3 Protection Systems used for undervoltage load-shedding systems installed to prevent system voltage collapse or voltage instability for BES reliability.
 - 4.2.4 Protection Systems installed as a Remedial Action Scheme (RAS) for BES reliability.
 - 4.2.5 Protection Systems and Sudden Pressure Relaying for generator Facilities that are part of the BES, except for generators identified through Inclusion I4 of the BES definition, including:
 - 4.2.5.1 Protection Systems that act to trip the generator either directly or via lockout or auxiliary tripping relays.
 - 4.2.5.2 Protection Systems and Sudden Pressure Relaying for generator step-up transformers for generators that are part of the BES.
 - 4.2.5.3 Protection Systems and Sudden Pressure Relaying for station service or excitation transformers connected to the generator bus of generators which are part of the BES, that act to trip the generator either directly or via lockout or tripping auxiliary relays.

4.2.6 Protection Systems and Sudden Pressure Relaying for the following BES generator Facilities for dispersed power producing resources identified through Inclusion I4 of the BES definition:

4.2.6.1 Protection Systems and Sudden Pressure Relaying for Facilities used in aggregating dispersed BES generation from the point where those resources aggregate to greater than 75 MVA to a common point of connection at 100kV or above.

4.2.7 Automatic Reclosing¹, including:

4.2.7.1 Automatic Reclosing applied on the terminals of Elements connected to the BES bus located at generating plant substations where the total installed gross generating plant capacity is greater than the gross capacity of the largest BES generating unit within the Balancing Authority Area or, if a member of a Reserve Sharing Group, the largest generating unit within the Reserve Sharing Group.²

4.2.7.2 Automatic Reclosing applied on the terminals of all BES Elements at substations one bus away from generating plants specified in Section 4.2.7.1 when the substation is less than 10 circuit-miles from the generating plant substation.

4.2.7.3 Automatic Reclosing applied as an integral part of an RAS specified in Section 4.2.4.

5. Effective Date: See the Implementation Plan for this standard.

6. Definitions Used in this Standard:

Automatic Reclosing – Includes the following Components:

- Reclosing relay
- Supervisory relay(s) – relay(s) that perform voltage and/or sync check functions that enable or disable operation of the reclosing relay

Rationale for revisions to Automatic Reclosing: To address directives from FERC Order No. 803 addressing Automatic Reclosing, the definition for Automatic Reclosing was revised to add supervisory relays, the associated voltage sensing devices, and the associated control circuitry.

¹ Automatic Reclosing addressed in Section 4.2.7.1 and 4.2.7.2 may be excluded if the equipment owner can demonstrate that a close-in three-phase fault present for twice the normal clearing time (capturing a minimum trip-close-trip time delay) does not result in a total loss of gross generation in the Interconnection exceeding the gross capacity of the largest relevant BES generating unit where the Automatic Reclosing is applied.

² The largest BES generating unit within the Balancing Authority Area or the largest generating unit within the Reserve Sharing Group, as applicable, is subject to change. As a result of such a change, the Automatic Reclosing Components subject to the standard could change effective on the date of such change.

- Voltage sensing devices associated with the supervisory relay(s)
- Control circuitry associated with the reclosing relay or supervisory relay(s)

Sudden Pressure Relaying – A system that trips an interrupting device(s) to isolate the equipment it is monitoring and includes the following Components:

- Fault pressure relay – a mechanical relay or device that detects rapid changes in gas pressure, oil pressure, or oil flow that are indicative of Faults within liquid-filled, wire-wound equipment
- Control circuitry associated with a fault pressure relay

Unresolved Maintenance Issue – A deficiency identified during a maintenance activity that causes the Component to not meet the intended performance, cannot be corrected during the maintenance interval, and requires follow-up corrective action.

Segment – Components of a consistent design standard, or a particular model or type from a single manufacturer that typically share other common elements. Consistent performance is expected across the entire population of a Segment. A Segment must contain at least sixty (60) individual Components.

Component Type –

- Any one of the five specific elements of a Protection System.
- Any one of the four specific elements of Automatic Reclosing.
- Any one of the two specific elements of Sudden Pressure Relaying.

Rationale for revisions to Component Type:

With the revision of the definition of Automatic Reclosing, there are four specific elements of this definition, rather than two as stated in the prior version.

Component – Any individual discrete piece of equipment included in a Protection System, Automatic Reclosing, or Sudden Pressure Relaying.

Countable Event – A failure of a Component requiring repair or replacement, any condition discovered during the maintenance activities in Tables 1-1 through 1-5, Table 3, Tables 4-1 through 4-3, and Table 5, which requires corrective action or a Protection System Misoperation attributed to hardware failure or calibration failure.

Misoperations due to product design errors, software errors, relay settings different from specified settings, Protection System Component, Automatic Reclosing, or Sudden Pressure Relaying configuration or application errors are not included in Countable Events.

B. Requirements and Measures

- R1.** Each Transmission Owner, Generator Owner, and Distribution Provider shall establish a Protection System Maintenance Program (PSMP) for its Protection Systems, Automatic Reclosing, and Sudden Pressure Relaying identified in Section 4.2, Facilities. *[Violation Risk Factor: Medium] [Time Horizon: Operations Planning]*

The PSMP shall:

- 1.1.** Identify which maintenance method (time-based, performance-based per PRC-005 Attachment A, or a combination) is used to address each Protection System, Automatic Reclosing, and Sudden Pressure Relaying Component Type. All batteries associated with the station DC supply Component Type of a Protection System shall be included in a time-based program as described in Table 1-4 and Table 3.
- 1.2.** Include the applicable monitored Component attributes applied to each Protection System, Automatic Reclosing, and Sudden Pressure Relaying Component Type consistent with the maintenance intervals specified in Tables 1-1 through 1-5, Table 2, Table 3, Table 4-1 through 4-3, and Table 5 where monitoring is used to extend the maintenance intervals beyond those specified for unmonitored Protection System, Automatic Reclosing, and Sudden Pressure Relaying Components.
- M1.** Each Transmission Owner, Generator Owner and Distribution Provider shall have a documented PSMP in accordance with Requirement R1.

For each Protection System, Automatic Reclosing, and Sudden Pressure Relaying Component Type, the documentation shall include the type of maintenance method applied (time-based, performance-based, or a combination of these maintenance methods), and shall include all batteries associated with the station DC supply Component Types in a time-based program as described in Table 1-4 and Table 3. (Part 1.1)

For Component Types that use monitoring to extend the maintenance intervals, the responsible entity(s) shall have evidence for each Protection System, Automatic Reclosing, and Sudden Pressure Relaying Component Type (such as manufacturer's specifications or engineering drawings) of the appropriate monitored Component attributes as specified in Tables 1-1 through 1-5, Table 2, Table 3, Table 4-1 through 4-3, and Table 5. (Part 1.2)

- R2.** Each Transmission Owner, Generator Owner, and Distribution Provider that uses performance-based maintenance intervals in its PSMP shall follow the procedure established in PRC-005 Attachment A to establish and maintain its performance-based intervals. *[Violation Risk Factor: Medium] [Time Horizon: Operations Planning]*
- M2.** Each Transmission Owner, Generator Owner, and Distribution Provider that uses performance-based maintenance intervals shall have evidence that its current performance-based maintenance program(s) is in accordance with Requirement R2,

which may include, but is not limited to, Component lists, dated maintenance records, and dated analysis records and results.

- R3.** Each Transmission Owner, Generator Owner, and Distribution Provider that utilizes time-based maintenance program(s) shall maintain its Protection System, Automatic Reclosing, and Sudden Pressure Relaying Components that are included within the time-based maintenance program in accordance with the minimum maintenance activities and maximum maintenance intervals prescribed within Tables 1-1 through 1-5, Table 2, Table 3, Table 4-1 through 4-3, and Table 5. *[Violation Risk Factor: High]*
[Time Horizon: Operations Planning]
- M3.** Each Transmission Owner, Generator Owner, and Distribution Provider that utilizes time-based maintenance program(s) shall have evidence that it has maintained its Protection System, Automatic Reclosing, and Sudden Pressure Relaying Components included within its time-based program in accordance with Requirement R3. The evidence may include, but is not limited to, dated maintenance records, dated maintenance summaries, dated check-off lists, dated inspection records, or dated work orders.
- R4.** Each Transmission Owner, Generator Owner, and Distribution Provider that utilizes performance-based maintenance program(s) in accordance with Requirement R2 shall implement and follow its PSMP for its Protection System, Automatic Reclosing, and Sudden Pressure Relaying Components that are included within the performance-based program(s). *[Violation Risk Factor: High]* *[Time Horizon: Operations Planning]*
- M4.** Each Transmission Owner, Generator Owner, and Distribution Provider that utilizes performance-based maintenance intervals in accordance with Requirement R2 shall have evidence that it has implemented the PSMP for the Protection System, Automatic Reclosing, and Sudden Pressure Relaying Components included in its performance-based program in accordance with Requirement R4. The evidence may include, but is not limited to, dated maintenance records, dated maintenance summaries, dated check-off lists, dated inspection records, or dated work orders.
- R5.** Each Transmission Owner, Generator Owner, and Distribution Provider shall demonstrate efforts to correct identified Unresolved Maintenance Issues. *[Violation Risk Factor: Medium]* *[Time Horizon: Operations Planning]*
- M5.** Each Transmission Owner, Generator Owner, and Distribution Provider shall have evidence that it has undertaken efforts to correct identified Unresolved Maintenance Issues in accordance with Requirement R5. The evidence may include, but is not limited to, work orders, replacement Component orders, invoices, project schedules with completed milestones, return material authorizations (RMAs) or purchase orders.

C. Compliance

1. Compliance Monitoring Process

1.1. Compliance Enforcement Authority

As defined in the NERC Rules of Procedure, “Compliance Enforcement Authority” means NERC or the Regional Entity in their respective roles of monitoring and enforcing compliance with the NERC Reliability Standards.

1.2. Evidence Retention

The following evidence retention periods identify the period of time an entity is required to retain specific evidence to demonstrate compliance. For instances where the evidence retention period specified below is shorter than the time since the last audit, the Compliance Enforcement Authority may ask an entity to provide other evidence to show that it was compliant for the full time period since the last audit.

The Transmission Owner, Generator Owner, and Distribution Provider shall each keep data or evidence to show compliance as identified below unless directed by its Compliance Enforcement Authority to retain specific evidence for a longer period of time as part of an investigation.

For Requirement R1, the Transmission Owner, Generator Owner, and Distribution Provider shall each keep its current dated PSMP, as well as any superseded versions since the preceding compliance audit, including the documentation that specifies the type of maintenance program applied for each Protection System, Automatic Reclosing, or Sudden Pressure Relaying Component Type.

For Requirement R2, Requirement R3, and Requirement R4, in cases where the interval of the maintenance activity is longer than the audit cycle, the Transmission Owner, Generator Owner, and Distribution Provider shall each keep documentation of the most recent performance of that maintenance activity for the Protection System, Automatic Reclosing, or Sudden Pressure Relaying Component. In cases where the interval of the maintenance activity is shorter than the audit cycle, documentation of all performances (in accordance with the tables) of that maintenance activity for the Protection System, Automatic Reclosing, or Sudden Pressure Relaying Component since the previous scheduled audit date shall be retained.

For Requirement R5 the Transmission Owner, Generator Owner, and Distribution Provider shall each keep documentation of Unresolved Maintenance Issues identified by the entity since the last audit, including all that were resolved since the last audit.

The Compliance Enforcement Authority shall keep the last audit records and all requested and submitted subsequent audit records.

1.3. Compliance Monitoring and Assessment Processes:

Compliance Audits

Self-Certifications

Spot Checking

Compliance Violation Investigations

Self-Reporting

Complaints

1.4. Additional Compliance Information

None

Table of Compliance Elements

Requirement Number	Lower VSL	Moderate VSL	High VSL	Severe VSL
R1	The entity's PSMP failed to specify whether one Component Type is being addressed by time-based or performance-based maintenance, or a combination of both (Part 1.1).	The entity's PSMP failed to specify whether two Component Types are being addressed by time-based or performance-based maintenance, or a combination of both (Part 1.1).	<p>The entity's PSMP failed to specify whether three Component Types are being addressed by time-based or performance-based maintenance, or a combination of both. (Part 1.1).</p> <p>OR</p> <p>The entity's PSMP failed to include the applicable monitoring attributes applied to each Component Type consistent with the maintenance intervals specified in Tables 1-1 through 1-5, Table 2, Table 3, Tables 4-1 through 4-3, and Table 5 where monitoring is used to extend the maintenance intervals beyond those specified for unmonitored Components (Part 1.2).</p>	<p>The entity failed to establish a PSMP.</p> <p>OR</p> <p>The entity's PSMP failed to specify whether four or more Component Types are being addressed by time-based or performance-based maintenance, or a combination of both (Part 1.1).</p> <p>OR</p> <p>The entity's PSMP failed to include applicable station batteries in a time-based program (Part 1.1).</p>
R2	The entity uses performance-based maintenance intervals in its PSMP but failed to reduce Countable Events to no more than 4% within three years.	NA	The entity uses performance-based maintenance intervals in its PSMP but failed to reduce Countable Events to no more than 4% within four years.	<p>The entity uses performance-based maintenance intervals in its PSMP but:</p> <ol style="list-style-type: none"> 1) Failed to establish the technical justification described within Requirement R2 for the initial use of the performance-based PSMP <p>OR</p> <ol style="list-style-type: none"> 2) Failed to reduce Countable Events to no more than 4% within five years <p>OR</p>

Requirement Number	Lower VSL	Moderate VSL	High VSL	Severe VSL
				3) Maintained a Segment with less than 60 Components OR 4) Failed to: <ul style="list-style-type: none"> • Annually update the list of Components, OR • Annually perform maintenance on the greater of 5% of the Segment population or 3 Components, OR • Annually analyze the program activities and results for each Segment.
R3	For Components included within a time-based maintenance program, the entity failed to maintain 5% or less of the total Components included within a specific Component Type in accordance with the minimum maintenance activities and maximum maintenance intervals prescribed within Tables 1-1 through 1-5, Table 2, Table 3, Tables 4-1 through 4-3, and Table 5.	For Components included within a time-based maintenance program, the entity failed to maintain more than 5% but 10% or less of the total Components included within a specific Component Type in accordance with the minimum maintenance activities and maximum maintenance intervals prescribed within Tables 1-1 through 1-5, Table 2, Table 3, Tables 4-1 through 4-3, and Table 5.	For Components included within a time-based maintenance program, the entity failed to maintain more than 10% but 15% or less of the total Components included within a specific Component Type in accordance with the minimum maintenance activities and maximum maintenance intervals prescribed within Tables 1-1 through 1-5, Table 2, Table 3, Tables 4-1 through 4-3, and Table 5.	For Components included within a time-based maintenance program, the entity failed to maintain more than 15% of the total Components included within a specific Component Type in accordance with the minimum maintenance activities and maximum maintenance intervals prescribed within Tables 1-1 through 1-5, Table 2, Table 3, Tables 4-1 through 4-3, and Table 5.

Requirement Number	Lower VSL	Moderate VSL	High VSL	Severe VSL
R4	For Components included within a performance-based maintenance program, the entity failed to maintain 5% or less of the annual scheduled maintenance for a specific Component Type in accordance with their performance-based PSMP.	For Components included within a performance-based maintenance program, the entity failed to maintain more than 5% but 10% or less of the annual scheduled maintenance for a specific Component Type in accordance with their performance-based PSMP.	For Components included within a performance-based maintenance program, the entity failed to maintain more than 10% but 15% or less of the annual scheduled maintenance for a specific Component Type in accordance with their performance-based PSMP.	For Components included within a performance-based maintenance program, the entity failed to maintain more than 15% of the annual scheduled maintenance for a specific Component Type in accordance with their performance-based PSMP.
R5	The entity failed to undertake efforts to correct 5 or fewer identified Unresolved Maintenance Issues.	The entity failed to undertake efforts to correct greater than 5 but less than or equal to 10 identified Unresolved Maintenance Issues.	The entity failed to undertake efforts to correct greater than 10 but less than or equal to 15 identified Unresolved Maintenance Issues.	The entity failed to undertake efforts to correct greater than 15 identified Unresolved Maintenance Issues.

D. Regional Variances

None.

E. Interpretations

None.

Supplemental Reference Documents

The following documents present a detailed discussion about determination of maintenance intervals and other useful information regarding establishment of a maintenance program.

1. *Supplementary Reference and FAQ - PRC-005 Protection System Maintenance*, Protection System Maintenance and Testing Standard Drafting Team (April 2015)
2. *Considerations for Maintenance and Testing of Auto-reclosing Schemes*, NERC System Analysis and Modeling Subcommittee, and NERC System Protection and Control Subcommittee (November 2012)
3. *Sudden Pressure Relays and Other Devices that Respond to Non-Electrical Quantities – SPCS Input for Standard Development in Response to FERC Order No. 758*, NERC System Protection and Control Subcommittee (December 2013)
4. *Sudden Pressure Relays and Other Devices that Respond to Non-Electrical Quantities – Supplemental Information to Support Project 2007-17.3: Protection System Maintenance and Testing* (October 31, 2014)

Version History

Version	Date	Action	Change Tracking
0	February 8, 2005	Adopted by NERC Board of Trustees	New.
1	February 7, 2006	Adopted by NERC Board of Trustees	<ol style="list-style-type: none"> 1. Changed incorrect use of certain hyphens (-) to “en dash” (–) and “em dash (—).” 2. Added “periods” to items where appropriate. Changed “Timeframe” to “Time Frame” in item D, 1.2.
1a	February 17, 2011	Adopted by NERC Board of Trustees	Added Appendix 1 - Interpretation regarding applicability of standard to protection of radially connected transformers developed in Project 2009-17.

Version	Date	Action	Change Tracking
1b	November 5, 2009	Adopted by NERC Board of Trustees	Interpretation of R1, R1.1, and R1.2 developed by Project 2009-10.
1b	February 3, 2012	FERC Order approving revised definition of “Protection System”	Per footnote 8 of FERC’s order, the definition of “Protection System” supersedes interpretation “b” of PRC-005-1b upon the effective date of the modified definition (i.e., April 1, 2013). <i>See N. Amer. Elec. Reliability Corp., 138 FERC ¶ 61,095 (February 3, 2012).</i>
1.1b	May 9, 2012	Adopted by NERC Board of Trustees	Errata change developed by Project 2010-07, clarified inclusion of generator interconnection Facility in Generator Owner’s responsibility.
2	November 7, 2012	Adopted by NERC Board of Trustees	Project 2007-17 - Complete revision, absorbing maintenance requirements from PRC-005-1.1b, PRC-008-0, PRC-011-0, PRC-017-0.
2	October 17, 2013	Approved by NERC Standards Committee	Errata Change: The Standards Committee approved an errata change to the implementation plan for PRC-005-2 to add the phrase “or as otherwise made effective pursuant to the laws applicable to such ERO governmental authorities;” to the second sentence under the “Retirement of Existing Standards” section. (no change to standard version number)
2	March 7, 2014	Adopted by NERC Board of Trustees	Modified R1 VSL in response to FERC directive (no change to standard version number).
2(i)	November 13, 2014	Adopted by NERC Board of Trustees	Applicability section revised by Project 2014-01 to clarify application of Requirements to BES dispersed power producing resources.

Version	Date	Action	Change Tracking
2(ii)	November 13, 2014	Adopted by NERC Board of Trustees	Replaced references to Special Protection System and SPS with Remedial Action Scheme and RAS.
3	November 7, 2013	Adopted by the NERC Board of Trustees	Revised to address the FERC directive in Order No. 758 to include Automatic Reclosing in maintenance programs.
3	February 12, 2014	Approved by NERC Standards Committee	Errata Change: The Standards Committee approved errata changes to correct capitalization of certain defined terms within the definitions of “Unresolved Maintenance Issue” and “Protection System Maintenance Program”. The changes will be reflected in the definitions section of PRC-005-3 for “Unresolved Maintenance Issue” and in the NERC Glossary of Terms for “Protection System Maintenance Program”. (no change to standard version number)
3	March 7, 2014	Adopted by NERC Board of Trustees	Modified R1 VSL in response to FERC directive (no change to standard version number).
3(i)	November 13, 2014	Adopted by NERC Board of Trustees	Applicability section revised by Project 2014-01 to clarify application of Requirements to BES dispersed power producing resources.
3(ii)	November 13, 2014	Adopted by NERC Board of Trustees	Replaced references to Special Protection System and SPS with Remedial Action Scheme and RAS.
4	November 13, 2014	Adopted by NERC Board of Trustees	Added Sudden Pressure Relaying in response to FERC Order No. 758.

Version	Date	Action	Change Tracking
5	TBD		Applicability section revised by Project 2014-01 to clarify application of Requirements to BES dispersed power producing resources.
6	TBD		Revised to add supervisory relays to Automatic Reclosing in accordance with the directives in FERC Order 803.

Table 1-1 Component Type - Protective Relay Excluding distributed UFLS and distributed UVLS (see Table 3)		
Component Attributes	Maximum Maintenance Interval ³	Maintenance Activities
Any unmonitored protective relay not having all the monitoring attributes of a category below.	6 Calendar Years	For all unmonitored relays: <ul style="list-style-type: none"> • Verify that settings are as specified For non-microprocessor relays: <ul style="list-style-type: none"> • Test and, if necessary calibrate For microprocessor relays: <ul style="list-style-type: none"> • Verify operation of the relay inputs and outputs that are essential to proper functioning of the Protection System. • Verify acceptable measurement of power system input values.
Monitored microprocessor protective relay with the following: <ul style="list-style-type: none"> • Internal self-diagnosis and alarming (see Table 2). • Voltage and/or current waveform sampling three or more times per power cycle, and conversion of samples to numeric values for measurement calculations by microprocessor electronics. • Alarming for power supply failure (see Table 2). 	12 Calendar Years	Verify: <ul style="list-style-type: none"> • Settings are as specified. • Operation of the relay inputs and outputs that are essential to proper functioning of the Protection System. • Acceptable measurement of power system input values.

³ For the tables in this standard, a calendar year starts on the first day of a new year (January 1) after a maintenance activity has been completed. For the tables in this standard, a calendar month starts on the first day of the first month after a maintenance activity has been completed.

Table 1-1 Component Type - Protective Relay Excluding distributed UFLS and distributed UVLS (see Table 3)		
Component Attributes	Maximum Maintenance Interval ³	Maintenance Activities
Monitored microprocessor protective relay with preceding row attributes and the following: <ul style="list-style-type: none"> • Ac measurements are continuously verified by comparison to an independent AC measurement source, with alarming for excessive error (See Table 2). • Some or all binary or status inputs and control outputs are monitored by a process that continuously demonstrates ability to perform as designed, with alarming for failure (See Table 2). • Alarming for change of settings (See Table 2). 	12 Calendar Years	Verify only the unmonitored relay inputs and outputs that are essential to proper functioning of the Protection System.

Table 1-2 Component Type - Communications Systems Excluding distributed UFLS and distributed UVLS (see Table 3)		
Component Attributes	Maximum Maintenance Interval	Maintenance Activities
Any unmonitored communications system necessary for correct operation of protective functions, and not having all the monitoring attributes of a category below.	4 Calendar Months	Verify that the communications system is functional.
	6 Calendar Years	Verify that the communications system meets performance criteria pertinent to the communications technology applied (e.g. signal level, reflected power, or data error rate). Verify operation of communications system inputs and outputs that are essential to proper functioning of the Protection System.
Any communications system with continuous monitoring or periodic automated testing for the presence of the channel function, and alarming for loss of function (See Table 2).	12 Calendar Years	Verify that the communications system meets performance criteria pertinent to the communications technology applied (e.g. signal level, reflected power, or data error rate). Verify operation of communications system inputs and outputs that are essential to proper functioning of the Protection System.
Any communications system with all of the following: <ul style="list-style-type: none"> • Continuous monitoring or periodic automated testing for the performance of the channel using criteria pertinent to the communications technology applied (e.g. signal level, reflected power, or data error rate, and alarming for excessive performance degradation). (See Table 2) • Some or all binary or status inputs and control outputs are monitored by a process that continuously demonstrates ability to perform as designed, with alarming for failure (See Table 2). 	12 Calendar Years	Verify only the unmonitored communications system inputs and outputs that are essential to proper functioning of the Protection System

Table 1-3 Component Type - Voltage and Current Sensing Devices Providing Inputs to Protective Relays Excluding distributed UFLS and distributed UVLS (see Table 3)		
Component Attributes	Maximum Maintenance Interval	Maintenance Activities
Any voltage and current sensing devices not having monitoring attributes of the category below.	12 Calendar Years	Verify that current and voltage signal values are provided to the protective relays.
Voltage and Current Sensing devices connected to microprocessor relays with AC measurements that are continuously verified by comparison of sensing input value, as measured by the microprocessor relay, to an independent AC measurement source, with alarming for unacceptable error or failure (see Table 2).	No periodic maintenance specified	None.

Table 1-4(a) Component Type – Protection System Station DC Supply Using Vented Lead-Acid (VLA) Batteries Excluding distributed UFLS and distributed UVLS (see Table 3)		
Protection System Station DC supply used only for non-BES interrupting devices for RAS, non-distributed UFLS systems, or non-distributed UVLS systems is excluded (see Table 1-4(e)).		
Component Attributes	Maximum Maintenance Interval	Maintenance Activities
Protection System Station DC supply using Vented Lead-Acid (VLA) batteries not having monitoring attributes of Table 1-4(f).	4 Calendar Months	Verify: <ul style="list-style-type: none"> • Station DC supply voltage Inspect: <ul style="list-style-type: none"> • Electrolyte level • For unintentional grounds
	18 Calendar Months	Verify: <ul style="list-style-type: none"> • Float voltage of battery charger • Battery continuity • Battery terminal connection resistance • Battery intercell or unit-to-unit connection resistance Inspect: <ul style="list-style-type: none"> • Cell condition of all individual battery cells where cells are visible – or measure battery cell/unit internal ohmic values where the cells are not visible • Physical condition of battery rack

<p style="text-align: center;">Table 1-4(a) Component Type – Protection System Station DC Supply Using Vented Lead-Acid (VLA) Batteries Excluding distributed UFLS and distributed UVLS (see Table 3)</p> <p style="text-align: center;">Protection System Station DC supply used only for non-BES interrupting devices for RAS, non-distributed UFLS systems, or non-distributed UVLS systems is excluded (see Table 1-4(e)).</p>		
Component Attributes	Maximum Maintenance Interval	Maintenance Activities
	<p>18 Calendar Months</p> <p style="text-align: center;">-or-</p> <p>6 Calendar Years</p>	<p>Verify that the station battery can perform as manufactured by evaluating cell/unit measurements indicative of battery performance (e.g. internal ohmic values or float current) against the station battery baseline.</p> <p style="text-align: center;">-or-</p> <p>Verify that the station battery can perform as manufactured by conducting a performance or modified performance capacity test of the entire battery bank.</p>

Table 1-4(b) Component Type – Protection System Station DC Supply Using Valve-Regulated Lead-Acid (VRLA) Batteries Excluding distributed UFLS and distributed UVLS (see Table 3)		
Protection System Station DC supply used only for non-BES interrupting devices for RAS, non-distributed UFLS systems, or non-distributed UVLS systems is excluded (see Table 1-4(e)).		
Component Attributes	Maximum Maintenance Interval	Maintenance Activities
Protection System Station DC supply with Valve Regulated Lead-Acid (VRLA) batteries not having monitoring attributes of Table 1-4(f).	4 Calendar Months	Verify: <ul style="list-style-type: none"> • Station DC supply voltage Inspect: <ul style="list-style-type: none"> • For unintentional grounds
	6 Calendar Months	Inspect: <ul style="list-style-type: none"> • Condition of all individual units by measuring battery cell/unit internal ohmic values.
	18 Calendar Months	Verify: <ul style="list-style-type: none"> • Float voltage of battery charger • Battery continuity • Battery terminal connection resistance • Battery intercell or unit-to-unit connection resistance Inspect: <ul style="list-style-type: none"> • Physical condition of battery rack

<p style="text-align: center;">Table 1-4(b) Component Type – Protection System Station DC Supply Using Valve-Regulated Lead-Acid (VRLA) Batteries Excluding distributed UFLS and distributed UVLS (see Table 3)</p> <p style="text-align: center;">Protection System Station DC supply used only for non-BES interrupting devices for RAS, non-distributed UFLS systems, or non-distributed UVLS systems is excluded (see Table 1-4(e)).</p>		
Component Attributes	Maximum Maintenance Interval	Maintenance Activities
	6 Calendar Months -or- 3 Calendar Years	Verify that the station battery can perform as manufactured by evaluating cell/unit measurements indicative of battery performance (e.g. internal ohmic values or float current) against the station battery baseline. -or- Verify that the station battery can perform as manufactured by conducting a performance or modified performance capacity test of the entire battery bank.

Table 1-4(c) Component Type – Protection System Station DC Supply Using Nickel-Cadmium (NiCad) Batteries Excluding distributed UFLS and distributed UVLS (see Table 3)		
Protection System Station DC supply used only for non-BES interrupting devices for RAS, non-distributed UFLS system, or non-distributed UVLS systems is excluded (see Table 1-4(e)).		
Component Attributes	Maximum Maintenance Interval	Maintenance Activities
Protection System Station DC supply Nickel-Cadmium (NiCad) batteries not having monitoring attributes of Table 1-4(f).	4 Calendar Months	Verify: <ul style="list-style-type: none"> • Station DC supply voltage Inspect: <ul style="list-style-type: none"> • Electrolyte level • For unintentional grounds
	18 Calendar Months	Verify: <ul style="list-style-type: none"> • Float voltage of battery charger • Battery continuity • Battery terminal connection resistance • Battery intercell or unit-to-unit connection resistance Inspect: <ul style="list-style-type: none"> • Cell condition of all individual battery cells. • Physical condition of battery rack

Table 1-4(c) Component Type – Protection System Station DC Supply Using Nickel-Cadmium (NiCad) Batteries Excluding distributed UFLS and distributed UVLS (see Table 3)		
Protection System Station DC supply used only for non-BES interrupting devices for RAS, non-distributed UFLS system, or non-distributed UVLS systems is excluded (see Table 1-4(e)).		
Component Attributes	Maximum Maintenance Interval	Maintenance Activities
	6 Calendar Years	Verify that the station battery can perform as manufactured by conducting a performance or modified performance capacity test of the entire battery bank.

Table 1-4(d) Component Type – Protection System Station DC Supply Using Non Battery Based Energy Storage Excluding distributed UFLS and distributed UVLS (see Table 3) Protection System Station DC supply used only for non-BES interrupting devices for RAS, non-distributed UFLS system, or non-distributed UVLS systems is excluded (see Table 1-4(e)).		
Component Attributes	Maximum Maintenance Interval	Maintenance Activities
Any Protection System station DC supply not using a battery and not having monitoring attributes of Table 1-4(f).	4 Calendar Months	Verify: <ul style="list-style-type: none"> • Station DC supply voltage Inspect: <ul style="list-style-type: none"> • For unintentional grounds
	18 Calendar Months	Inspect: Condition of non-battery based DC supply
	6 Calendar Years	Verify that the DC supply can perform as manufactured when AC power is not present.

Table 1-4(e)		
Component Type – Protection System Station DC Supply for non-BES Interrupting Devices for RAS, non-distributed UFLS, and non-distributed UVLS systems		
Component Attributes	Maximum Maintenance Interval	Maintenance Activities
Any Protection System DC supply used for tripping only non-BES interrupting devices as part of a RAS, non-distributed UFLS, or non-distributed UVLS system and not having monitoring attributes of Table 1-4(f).	When control circuits are verified (See Table 1-5)	Verify Station DC supply voltage.

Table 1-4(f) Exclusions for Protection System Station DC Supply Monitoring Devices and Systems		
Component Attributes	Maximum Maintenance Interval	Maintenance Activities
Any station DC supply with high and low voltage monitoring and alarming of the battery charger voltage to detect charger overvoltage and charger failure (See Table 2).	No periodic maintenance specified	No periodic verification of station DC supply voltage is required.
Any battery based station DC supply with electrolyte level monitoring and alarming in every cell (See Table 2).		No periodic inspection of the electrolyte level for each cell is required.
Any station DC supply with unintentional DC ground monitoring and alarming (See Table 2).		No periodic inspection of unintentional DC grounds is required.
Any station DC supply with charger float voltage monitoring and alarming to ensure correct float voltage is being applied on the station DC supply (See Table 2).		No periodic verification of float voltage of battery charger is required.
Any battery based station DC supply with monitoring and alarming of battery string continuity (See Table 2).		No periodic verification of the battery continuity is required.
Any battery based station DC supply with monitoring and alarming of the intercell and/or terminal connection detail resistance of the entire battery (See Table 2).		No periodic verification of the intercell and terminal connection resistance is required.
Any Valve Regulated Lead-Acid (VRLA) or Vented Lead-Acid (VLA) station battery with internal ohmic value or float current monitoring and alarming, and evaluating present values relative to baseline internal ohmic values for every cell/unit (See Table 2).		No periodic evaluation relative to baseline of battery cell/unit measurements indicative of battery performance is required to verify the station battery can perform as manufactured.
Any Valve Regulated Lead-Acid (VRLA) or Vented Lead-Acid (VLA) station battery with monitoring and alarming of each cell/unit internal ohmic value (See Table 2).		No periodic inspection of the condition of all individual units by measuring battery cell/unit internal ohmic values of a station VRLA or Vented Lead-Acid (VLA) battery is required.

Table 1-5 Component Type - Control Circuitry Associated With Protective Functions Excluding distributed UFLS and distributed UVLS (see Table 3), Automatic Reclosing (see Table 4), and Sudden Pressure Relaying (see Table 5) Note: Table requirements apply to all Control Circuitry Components of Protection Systems, and RAS except as noted.		
Component Attributes	Maximum Maintenance Interval	Maintenance Activities
Trip coils or actuators of circuit breakers, interrupting devices, or mitigating devices (regardless of any monitoring of the control circuitry).	6 Calendar Years	Verify that each trip coil is able to operate the circuit breaker, interrupting device, or mitigating device.
Electromechanical lockout devices which are directly in a trip path from the protective relay to the interrupting device trip coil (regardless of any monitoring of the control circuitry).	6 Calendar Years	Verify electrical operation of electromechanical lockout devices.
Unmonitored control circuitry associated with RAS. (See Table 4-2(b) for RAS which include Automatic Reclosing.)	12 Calendar Years	Verify all paths of the control circuits essential for proper operation of the RAS.
Unmonitored control circuitry associated with protective functions inclusive of all auxiliary relays.	12 Calendar Years	Verify all paths of the trip circuits inclusive of all auxiliary relays through the trip coil(s) of the circuit breakers or other interrupting devices.
Control circuitry associated with protective functions and/or RAS whose integrity is monitored and alarmed (See Table 2).	No periodic maintenance specified	None.

<p align="center">Table 2 – Alarming Paths and Monitoring</p> <p align="center">In Tables 1-1 through 1-5, Table 3, Tables 4-1 through 4-3, and Table 5 alarm attributes used to justify extended maximum maintenance intervals and/or reduced maintenance activities are subject to the following maintenance requirements</p>		
Component Attributes	Maximum Maintenance Interval	Maintenance Activities
<p>Any alarm path through which alarms in Tables 1-1 through 1-5, Table 3, Tables 4-1 through 4-3, and Table 5 are conveyed from the alarm origin to the location where corrective action can be initiated, and not having all the attributes of the “Alarm Path with monitoring” category below.</p> <p>Alarms are reported within 24 hours of detection to a location where corrective action can be initiated.</p>	12 Calendar Years	Verify that the alarm path conveys alarm signals to a location where corrective action can be initiated.
<p>Alarm Path with monitoring:</p> <p>The location where corrective action is taken receives an alarm within 24 hours for failure of any portion of the alarming path from the alarm origin to the location where corrective action can be initiated.</p>	No periodic maintenance specified	None.

Table 3 Maintenance Activities and Intervals for distributed UFLS and distributed UVLS Systems		
Component Attributes	Maximum Maintenance Interval	Maintenance Activities
Any unmonitored protective relay not having all the monitoring attributes of a category below.	6 Calendar Years	<p>Verify that settings are as specified.</p> <p>For non-microprocessor relays:</p> <ul style="list-style-type: none"> • Test and, if necessary calibrate. <p>For microprocessor relays:</p> <ul style="list-style-type: none"> • Verify operation of the relay inputs and outputs that are essential to proper functioning of the Protection System. • Verify acceptable measurement of power system input values.
<p>Monitored microprocessor protective relay with the following:</p> <ul style="list-style-type: none"> • Internal self-diagnosis and alarming (See Table 2). • Voltage and/or current waveform sampling three or more times per power cycle, and conversion of samples to numeric values for measurement calculations by microprocessor electronics. <p>Alarming for power supply failure (See Table 2).</p>	12 Calendar Years	<p>Verify:</p> <ul style="list-style-type: none"> • Settings are as specified. • Operation of the relay inputs and outputs that are essential to proper functioning of the Protection System. • Acceptable measurement of power system input values.
<p>Monitored microprocessor protective relay with preceding row attributes and the following:</p> <ul style="list-style-type: none"> • Ac measurements are continuously verified by comparison to an independent AC measurement source, with alarming for excessive error (See Table 2). 	12 Calendar Years	<p>Verify only the unmonitored relay inputs and outputs that are essential to proper functioning of the Protection System.</p>

Table 3 Maintenance Activities and Intervals for distributed UFLS and distributed UVLS Systems		
Component Attributes	Maximum Maintenance Interval	Maintenance Activities
<ul style="list-style-type: none"> Some or all binary or status inputs and control outputs are monitored by a process that continuously demonstrates ability to perform as designed, with alarming for failure (See Table 2). Alarming for change of settings (See Table 2).		
Voltage and/or current sensing devices associated with UFLS or UVLS systems.	12 Calendar Years	Verify that current and/or voltage signal values are provided to the protective relays.
Protection System DC supply for tripping non-BES interrupting devices used only for a UFLS or UVLS system.	12 Calendar Years	Verify Protection System DC supply voltage.
Control circuitry between the UFLS or UVLS relays and electromechanical lockout and/or tripping auxiliary devices (excludes non-BES interrupting device trip coils).	12 Calendar Years	Verify the path from the relay to the lockout and/or tripping auxiliary relay (including essential supervisory logic).
Electromechanical lockout and/or tripping auxiliary devices associated only with UFLS or UVLS systems (excludes non-BES interrupting device trip coils).	12 Calendar Years	Verify electrical operation of electromechanical lockout and/or tripping auxiliary devices.
Control circuitry between the electromechanical lockout and/or tripping auxiliary devices and the non-BES interrupting devices in UFLS or UVLS systems, or between UFLS or UVLS relays (with no interposing electromechanical lockout or auxiliary device) and the non-BES interrupting devices (excludes non-BES interrupting device trip coils).	No periodic maintenance specified	None.
Trip coils of non-BES interrupting devices in UFLS or UVLS systems.	No periodic maintenance specified	None.

<p style="text-align: center;">Table 4-1 Maintenance Activities and Intervals for Automatic Reclosing Components Component Type – Reclosing and Supervisory Relay</p>		
<p>Note: In cases where Components of Automatic Reclosing are common to Components listed in Table 1-1 through 1-5, the Components only need to be tested once during a distinct maintenance interval.</p>		
Component Attributes	Maximum Maintenance Interval	Maintenance Activities
<p>Any unmonitored reclosing relay or supervisory relay not having all the monitoring attributes of a category below.</p>	<p>6 Calendar Years</p>	<p>Verify that settings are as specified.</p> <p>For non-microprocessor relays:</p> <ul style="list-style-type: none"> • Test and, if necessary calibrate <p>For microprocessor relays:</p> <ul style="list-style-type: none"> • Verify operation of the relay inputs and outputs that are essential to proper functioning of the Automatic Reclosing. <p>For microprocessor supervisory relays:</p> <ul style="list-style-type: none"> • Verify acceptable measurement of power system input values.
<ul style="list-style-type: none"> • Monitored microprocessor reclosing relay or supervisory relay with the following: Internal self-diagnosis and alarming (See Table 2). • Alarming for power supply failure (See Table 2). <p>For supervisory relay:</p> <ul style="list-style-type: none"> • Voltage waveform sampling three or more times per power cycle, and conversion of samples to numeric values for measurement calculations by microprocessor electronics. 	<p>12 Calendar Years</p>	<p>Verify:</p> <ul style="list-style-type: none"> • Settings are as specified. <p>Operation of the relay inputs and outputs that are essential to proper functioning of the Automatic Reclosing.</p> <p>For supervisory relays:</p> <ul style="list-style-type: none"> • Verify acceptable measurement of power system input values.

Table 4-1 Maintenance Activities and Intervals for Automatic Reclosing Components Component Type – Reclosing and Supervisory Relay		
Note: In cases where Components of Automatic Reclosing are common to Components listed in Table 1-1 through 1-5, the Components only need to be tested once during a distinct maintenance interval.		
Component Attributes	Maximum Maintenance Interval	Maintenance Activities
Monitored microprocessor reclosing relay or supervisory relay with preceding row attributes and the following: <ul style="list-style-type: none"> Some or all binary or status inputs and control outputs are monitored by a process that continuously demonstrates ability to perform as designed, with alarming for failure (See Table 2). Alarming for change of settings (See Table 2). For supervisory relay: <ul style="list-style-type: none"> AC measurements are continuously verified by comparison to an independent AC measurement source, with alarming for excessive error (See Table 2). 	12 Calendar Years	Verify only the unmonitored relay inputs and outputs that are essential to proper functioning of the Automatic Reclosing.

Table 4-2(a) Maintenance Activities and Intervals for Automatic Reclosing Components Component Type – Control Circuitry Associated with Reclosing and Supervisory Relays that are NOT an Integral Part of an RAS		
Component Attributes	Maximum Maintenance Interval	Maintenance Activities
Unmonitored Control circuitry associated with Automatic Reclosing that is not an integral part of an RAS.	12 Calendar Years	Verify that Automatic Reclosing, upon initiation, does not issue a premature closing command to the close circuitry.
Control circuitry associated with Automatic Reclosing that is not part of an RAS and is monitored and alarmed for conditions that would result in a premature closing command. (See Table 2)	No periodic maintenance specified	None.

Table 4-2(b) Maintenance Activities and Intervals for Automatic Reclosing Components Component Type – Control Circuitry Associated with Reclosing and Supervisory Relays that ARE an Integral Part of an RAS		
Component Attributes	Maximum Maintenance Interval	Maintenance Activities
Close coils or actuators of circuit breakers or similar devices that are used in conjunction with Automatic Reclosing as part of an RAS (regardless of any monitoring of the control circuitry).	6 Calendar Years	Verify that each close coil or actuator is able to operate the circuit breaker or mitigating device.
Unmonitored close control circuitry associated with Automatic Reclosing used as an integral part of an RAS.	12 Calendar Years	Verify all paths of the control circuits associated with Automatic Reclosing that are essential for proper operation of the RAS.
Control circuitry associated with Automatic Reclosing that is an integral part of an RAS whose integrity is monitored and alarmed. (See Table 2)	No periodic maintenance specified	None.

Table 4-3 Maintenance Activities and Intervals for Automatic Reclosing Components Component Type – Voltage Sensing Devices Associated with Supervisory Relays		
Component Attributes	Maximum Maintenance Interval	Maintenance Activities
Any voltage sensing devices not having monitoring attributes of the category below.	12 Calendar Years	Verify that voltage signal values are provided to the supervisory relays.
Voltage sensing devices that are connected to microprocessor supervisory relays with AC measurements that are continuously verified by comparison of sensing input value, as measured by the microprocessor relay, to an independent AC measurement source, with alarming for unacceptable error or failure. (See Table 2)	No periodic maintenance specified	None.

<p style="text-align: center;">Table 5 Maintenance Activities and Intervals for Sudden Pressure Relaying</p> <p style="text-align: center;">Note: In cases where Components of Sudden Pressure Relaying are common to Components listed in Table 1-5, the Components only need to be tested once during a distinct maintenance interval.</p>		
Component Attributes	Maximum Maintenance Interval	Maintenance Activities
Any fault pressure relay.	6 Calendar Years	Verify the pressure or flow sensing mechanism is operable.
Electromechanical lockout devices which are directly in a trip path from the fault pressure relay to the interrupting device trip coil (regardless of any monitoring of the control circuitry).	6 Calendar Years	Verify electrical operation of electromechanical lockout devices.
Unmonitored control circuitry associated with Sudden Pressure Relaying.	12 Calendar Years	Verify all paths of the trip circuits inclusive of all auxiliary relays through the trip coil(s) of the circuit breakers or other interrupting devices.
Control circuitry associated with Sudden Pressure Relaying whose integrity is monitored and alarmed (See Table 2).	No periodic maintenance specified	None.

PRC-005 — Attachment A

Criteria for a Performance-Based Protection System Maintenance Program

Purpose: To establish a technical basis for initial and continued use of a performance-based Protection System Maintenance Program (PSMP).

To establish the technical justification for the initial use of a performance-based PSMP:

1. Develop a list with a description of Components included in each designated Segment, with a minimum Segment population of 60 Components.
2. Maintain the Components in each Segment according to the time-based maximum allowable intervals established in Tables 1-1 through 1-5, Table 3, Tables 4-1 through 4-3, and Table 5 until results of maintenance activities for the Segment are available for a minimum of 30 individual Components of the Segment.
3. Document the maintenance program activities and results for each Segment, including maintenance dates and Countable Events for each included Component.
4. Analyze the maintenance program activities and results for each Segment to determine the overall performance of the Segment and develop maintenance intervals.
5. Determine the maximum allowable maintenance interval for each Segment such that the Segment experiences Countable Events on no more than 4% of the Components within the Segment, for the greater of either the last 30 Components maintained or all Components maintained in the previous year.

To maintain the technical justification for the ongoing use of a performance-based PSMP:

1. At least annually, update the list of Components and Segments and/or description if any changes occur within the Segment.
2. Perform maintenance on the greater of 5% of the Components (addressed in the performance based PSMP) in each Segment or 3 individual Components within the Segment in each year.
3. For the prior year, analyze the maintenance program activities and results for each Segment to determine the overall performance of the Segment.
4. Using the prior year's data, determine the maximum allowable maintenance interval for each Segment such that the Segment experiences Countable Events on no more than 4% of the Components within the Segment, for the greater of either the last 30 Components maintained or all Components maintained in the previous year.

If the Components in a Segment maintained through a performance-based PSMP experience 4% or more Countable Events, develop, document, and implement an action plan to reduce the Countable Events to less than 4% of the Segment population within 3 years.

Rationale:

During development of this standard, text boxes were embedded within the standard to explain the rationale for various parts of the standard. Upon BOT approval, the text from the rationale text boxes was moved to this section.

Standard Development Timeline

This section is maintained by the drafting team during the development of the standard and will be removed when the standard becomes effective.

Development Steps Completed

1. SAR posted for comment March 12 – April 10, 2015.

Description of Current Draft

This version of PRC-005 is posted for a 45-day concurrent comment and ballot period to address directives from [FERC Order No. 803](#), addressing Automatic Reclosing. Specifically, supervisory relays, associated voltage sensing devices, and associated control circuitry were added.

Anticipated Actions	Anticipated Dates
45-day Formal Comment Period with Parallel Ballot	May 2015 – July 2015
Final ballot	July 2015
BOT adoption	August 2015

Definitions of Terms Used in Standard

This section includes all newly defined or revised terms used in the proposed standard. Terms already defined in the Reliability Standards Glossary of Terms (Glossary) are not repeated here. New or revised definitions listed below become approved when the proposed standard is approved. When the standard becomes effective, this defined term will be removed from the individual standard and added to the Glossary.

Automatic Reclosing (see [Section 6](#) of the Standard)

A. Introduction

1. **Title:** Protection System, Automatic Reclosing, and Sudden Pressure Relaying Maintenance
2. **Number:** PRC-005-~~65~~
3. **Purpose:** To document and implement programs for the maintenance of all Protection Systems, Automatic Reclosing, and Sudden Pressure Relaying affecting the reliability of the Bulk Electric System (BES) so that they are kept in working order.
4. **Applicability:**
 - 4.1. **Functional Entities:**
 - 4.1.1 Transmission Owner
 - 4.1.2 Generator Owner
 - 4.1.3 Distribution Provider
 - 4.2. **Facilities:**
 - 4.2.1 Protection Systems and Sudden Pressure Relaying that are installed for the purpose of detecting Faults on BES Elements (lines, buses, transformers, etc.)
 - 4.2.2 Protection Systems used for underfrequency load-shedding systems installed per ERO underfrequency load-shedding requirements.
 - 4.2.3 Protection Systems used for undervoltage load-shedding systems installed to prevent system voltage collapse or voltage instability for BES reliability.
 - 4.2.4 Protection Systems installed as a Remedial Action Scheme (RAS) for BES reliability.
 - 4.2.5 Protection Systems and Sudden Pressure Relaying for generator Facilities that are part of the BES, except for generators identified through Inclusion I4 of the BES definition, including:
 - 4.2.5.1 Protection Systems that act to trip the generator either directly or via lockout or auxiliary tripping relays.
 - 4.2.5.2 Protection Systems and Sudden Pressure Relaying for generator step-up transformers for generators that are part of the BES.
 - 4.2.5.3 Protection Systems and Sudden Pressure Relaying for station service or excitation transformers connected to the generator bus of generators which are part of the BES, that act to trip the generator either directly or via lockout or tripping auxiliary relays.

4.2.6 Protection Systems and Sudden Pressure Relaying for the following BES generator Facilities for dispersed power producing resources identified through Inclusion I4 of the BES definition:

4.2.6.1 Protection Systems and Sudden Pressure Relaying for Facilities used in aggregating dispersed BES generation from the point where those resources aggregate to greater than 75 MVA to a common point of connection at 100kV or above.

4.2.7 Automatic Reclosing¹, including:

4.2.7.1 Automatic Reclosing applied on the terminals of Elements connected to the BES bus located at generating plant substations where the total installed gross generating plant capacity is greater than the gross capacity of the largest BES generating unit within the Balancing Authority Area or, if a member of a Reserve Sharing Group, the largest generating unit within the Reserve Sharing Group.²

4.2.7.2 Automatic Reclosing applied on the terminals of all BES Elements at substations one bus away from generating plants specified in Section 4.2.7.1 when the substation is less than 10 circuit-miles from the generating plant substation.

4.2.7.3 Automatic Reclosing applied as an integral part of an RAS specified in Section 4.2.4.

5. Effective Date: See the Implementation Plan for this standard.

6. Definitions Used in this Standard:

¹ Automatic Reclosing addressed in Section 4.2.7.1 and 4.2.7.2 may be excluded if the equipment owner can demonstrate that a close-in three-phase fault present for twice the normal clearing time (capturing a minimum trip-close-trip time delay) does not result in a total loss of gross generation in the Interconnection exceeding the gross capacity of the largest relevant BES generating unit where the Automatic Reclosing is applied.

² The largest BES generating unit within the Balancing Authority Area or the largest generating unit within the Reserve Sharing Group, as applicable, is subject to change. As a result of such a change, the Automatic Reclosing Components subject to the standard could change effective on the date of such change.

Automatic Reclosing – Includes the following Components:

- Reclosing relay
- Supervisory relay(s) – relay(s) that perform voltage and/or sync check functions that enable or disable operation of the reclosing relay
- Voltage sensing devices associated with the supervisory relay(s)
- Control circuitry associated with the reclosing relay or supervisory relay(s)

Rationale for revisions to Automatic Reclosing: To address directives from FERC Order No. 803 addressing Automatic Reclosing, the definition for Automatic Reclosing was revised to add supervisory relays, the associated voltage sensing devices, and the associated control circuitry.

Sudden Pressure Relaying – A system that trips an interrupting device(s) to isolate the equipment it is monitoring and includes the following Components:

- Fault pressure relay – a mechanical relay or device that detects rapid changes in gas pressure, oil pressure, or oil flow that are indicative of Faults within liquid-filled, wire-wound equipment
- Control circuitry associated with a fault pressure relay

Unresolved Maintenance Issue – A deficiency identified during a maintenance activity that causes the Component to not meet the intended performance, cannot be corrected during the maintenance interval, and requires follow-up corrective action.

Segment – Components of a consistent design standard, or a particular model or type from a single manufacturer that typically share other common elements. Consistent performance is expected across the entire population of a Segment. A Segment must contain at least sixty (60) individual Components.

Component Type –

- Any one of the five specific elements of a Protection System.
- Any one of the ~~two~~ four specific elements of Automatic Reclosing.
- Any one of the two specific elements of Sudden Pressure Relaying.

Rationale for revisions to Component Type: With the revision of the definition of Automatic Reclosing, there are four specific elements of this definition, rather than two as stated in the prior version.

Component – Any individual discrete piece of equipment included in a Protection System, Automatic Reclosing, or Sudden Pressure Relaying.

Countable Event – A failure of a Component requiring repair or replacement, any condition discovered during the maintenance activities in Tables 1-1 through 1-5, Table

3, Tables 4-1 through 4-~~32~~, and Table 5, which requires corrective action or a Protection System Misoperation attributed to hardware failure or calibration failure. Misoperations due to product design errors, software errors, relay settings different from specified settings, Protection System Component, Automatic Reclosing, or Sudden Pressure Relaying configuration or application errors are not included in Countable Events.

B. Requirements and Measures

- R1.** Each Transmission Owner, Generator Owner, and Distribution Provider shall establish a Protection System Maintenance Program (PSMP) for its Protection Systems, Automatic Reclosing, and Sudden Pressure Relaying identified in Section 4.2, Facilities. *[Violation Risk Factor: Medium] [Time Horizon: Operations Planning]*

The PSMP shall:

- 1.1.** Identify which maintenance method (time-based, performance-based per PRC-005 Attachment A, or a combination) is used to address each Protection System, Automatic Reclosing, and Sudden Pressure Relaying Component Type. All batteries associated with the station ~~dc-DC~~ supply Component Type of a Protection System shall be included in a time-based program as described in Table 1-4 and Table 3.
 - 1.2.** Include the applicable monitored Component attributes applied to each Protection System, Automatic Reclosing, and Sudden Pressure Relaying Component Type consistent with the maintenance intervals specified in Tables 1-1 through 1-5, Table 2, Table 3, Table 4-1 through 4-~~32~~, and Table 5 where monitoring is used to extend the maintenance intervals beyond those specified for unmonitored Protection System, Automatic Reclosing, and Sudden Pressure Relaying Components.
- M1.** Each Transmission Owner, Generator Owner and Distribution Provider shall have a documented ~~PSMP Protection System Maintenance Program~~ in accordance with Requirement R1.

For each Protection System, Automatic Reclosing, and Sudden Pressure Relaying Component Type, the documentation shall include the type of maintenance method applied (time-based, performance-based, or a combination of these maintenance methods), and shall include all batteries associated with the station ~~dc-DC~~ supply Component Types in a time-based program as described in Table 1-4 and Table 3. (Part 1.1)

For Component Types that use monitoring to extend the maintenance intervals, the responsible entity(s) shall have evidence for each Protection System, Automatic Reclosing, and Sudden Pressure Relaying Component Type (such as manufacturer's specifications or engineering drawings) of the appropriate monitored Component attributes as specified in Tables 1-1 through 1-5, Table 2, Table 3, Table 4-1 through 4-~~32~~, and Table 5. (Part 1.2)

- R2.** Each Transmission Owner, Generator Owner, and Distribution Provider that uses performance-based maintenance intervals in its PSMP shall follow the procedure established in PRC-005 Attachment A to establish and maintain its performance-based intervals. *[Violation Risk Factor: Medium] [Time Horizon: Operations Planning]*
- M2.** Each Transmission Owner, Generator Owner, and Distribution Provider that uses performance-based maintenance intervals shall have evidence that its current performance-based maintenance program(s) is in accordance with Requirement R2, which may include, but is not limited to, Component lists, dated maintenance records, and dated analysis records and results.
- R3.** Each Transmission Owner, Generator Owner, and Distribution Provider that utilizes time-based maintenance program(s) shall maintain its Protection System, Automatic Reclosing, and Sudden Pressure Relaying Components that are included within the time-based maintenance program in accordance with the minimum maintenance activities and maximum maintenance intervals prescribed within Tables 1-1 through 1-5, Table 2, Table 3, Table 4-1 through 4-~~3~~2, and Table 5. *[Violation Risk Factor: High] [Time Horizon: Operations Planning]*
- M3.** Each Transmission Owner, Generator Owner, and Distribution Provider that utilizes time-based maintenance program(s) shall have evidence that it has maintained its Protection System, Automatic Reclosing, and Sudden Pressure Relaying Components included within its time-based program in accordance with Requirement R3. The evidence may include, but is not limited to, dated maintenance records, dated maintenance summaries, dated check-off lists, dated inspection records, or dated work orders.
- R4.** Each Transmission Owner, Generator Owner, and Distribution Provider that utilizes performance-based maintenance program(s) in accordance with Requirement R2 shall implement and follow its PSMP for its Protection System, Automatic Reclosing, and Sudden Pressure Relaying Components that are included within the performance-based program(s). *[Violation Risk Factor: High] [Time Horizon: Operations Planning]*
- M4.** Each Transmission Owner, Generator Owner, and Distribution Provider that utilizes performance-based maintenance intervals in accordance with Requirement R2 shall have evidence that it has implemented the ~~PSMP~~**Protection System Maintenance Program** for the Protection System, Automatic Reclosing, and Sudden Pressure Relaying Components included in its performance-based program in accordance with Requirement R4. The evidence may include, but is not limited to, dated maintenance records, dated maintenance summaries, dated check-off lists, dated inspection records, or dated work orders.
- R5.** Each Transmission Owner, Generator Owner, and Distribution Provider shall demonstrate efforts to correct identified Unresolved Maintenance Issues. *[Violation Risk Factor: Medium] [Time Horizon: Operations Planning]*
- M5.** Each Transmission Owner, Generator Owner, and Distribution Provider shall have evidence that it has undertaken efforts to correct identified Unresolved Maintenance

Issues in accordance with Requirement R5. The evidence may include, but is not limited to, work orders, replacement Component orders, invoices, project schedules with completed milestones, return material authorizations (RMAs) or purchase orders.

C. Compliance

1. Compliance Monitoring Process

1.1. Compliance Enforcement Authority

As defined in the NERC Rules of Procedure, “Compliance Enforcement Authority” means NERC or the Regional Entity in their respective roles of monitoring and enforcing compliance with the NERC Reliability Standards.

1.2. Evidence Retention

The following evidence retention periods identify the period of time an entity is required to retain specific evidence to demonstrate compliance. For instances where the evidence retention period specified below is shorter than the time since the last audit, the Compliance Enforcement Authority may ask an entity to provide other evidence to show that it was compliant for the full time period since the last audit.

The Transmission Owner, Generator Owner, and Distribution Provider shall each keep data or evidence to show compliance as identified below unless directed by its Compliance Enforcement Authority to retain specific evidence for a longer period of time as part of an investigation.

For Requirement R1, the Transmission Owner, Generator Owner, and Distribution Provider shall each keep its current dated ~~PSM~~Protection System Maintenance Program, as well as any superseded versions since the preceding compliance audit, including the documentation that specifies the type of maintenance program applied for each Protection System, Automatic Reclosing, or Sudden Pressure Relaying Component Type.

For Requirement R2, Requirement R3, and Requirement R4, in cases where the interval of the maintenance activity is longer than the audit cycle, the Transmission Owner, Generator Owner, and Distribution Provider shall each keep documentation of the most recent performance of that maintenance activity for the Protection System, Automatic Reclosing, or Sudden Pressure Relaying Component. In cases where the interval of the maintenance activity is shorter than the audit cycle, documentation of all performances (in accordance with the tables) of that maintenance activity for the Protection System, Automatic Reclosing, or Sudden Pressure Relaying Component since the previous scheduled audit date shall be retained.

For Requirement R5 the Transmission Owner, Generator Owner, and Distribution Provider shall each keep documentation of Unresolved Maintenance Issues identified by the entity since the last audit, including all that were resolved since the last audit.

The Compliance Enforcement Authority shall keep the last audit records and all requested and submitted subsequent audit records.

1.3. Compliance Monitoring and Assessment Processes:

Compliance Audits

Self-Certifications

Spot Checking

Compliance Violation Investigations

Self-Reporting

Complaints

1.4. Additional Compliance Information

None

Table of Compliance Elements

Requirement Number	Lower VSL	Moderate VSL	High VSL	Severe VSL
R1	The entity's PSMP failed to specify whether one Component Type is being addressed by time-based or performance-based maintenance, or a combination of both (Part 1.1).	The entity's PSMP failed to specify whether two Component Types are being addressed by time-based or performance-based maintenance, or a combination of both (Part 1.1).	The entity's PSMP failed to specify whether three Component Types are being addressed by time-based or performance-based maintenance, or a combination of both. (Part 1.1). OR The entity's PSMP failed to include the applicable monitoring attributes applied to each Component Type consistent with the maintenance intervals specified in Tables 1-1 through 1-5, Table 2, Table 3, Tables 4-1 through 4-32, and Table 5 where monitoring is used to extend the maintenance intervals beyond those specified for unmonitored Components (Part 1.2).	The entity failed to establish a PSMP. OR The entity's PSMP failed to specify whether four or more Component Types are being addressed by time-based or performance-based maintenance, or a combination of both (Part 1.1). OR The entity's PSMP failed to include applicable station batteries in a time-based program (Part 1.1).
R2	The entity uses performance-based maintenance intervals in its PSMP but failed to reduce Countable Events to no more than 4% within three years.	NA	The entity uses performance-based maintenance intervals in its PSMP but failed to reduce Countable Events to no more than 4% within four years.	The entity uses performance-based maintenance intervals in its PSMP but: 1) Failed to establish the technical justification described within Requirement R2 for the initial use of the performance-based PSMP OR 2) Failed to reduce Countable Events to no more than 4% within five years OR 3) Maintained a Segment with

Requirement Number	Lower VSL	Moderate VSL	High VSL	Severe VSL
				less than 60 Components OR 4) Failed to: <ul style="list-style-type: none"> • Annually update the list of Components, <li style="text-align: center;">OR • Annually perform maintenance on the greater of 5% of the Segment population or 3 Components, <li style="text-align: center;">OR • Annually analyze the program activities and results for each Segment.
R3	For Components included within a time-based maintenance program, the entity failed to maintain 5% or less of the total Components included within a specific Component Type in accordance with the minimum maintenance activities and maximum maintenance intervals prescribed within Tables 1-1 through 1-5, Table 2, Table 3, Tables 4-1 through 4-23, and Table 5.	For Components included within a time-based maintenance program, the entity failed to maintain more than 5% but 10% or less of the total Components included within a specific Component Type in accordance with the minimum maintenance activities and maximum maintenance intervals prescribed within Tables 1-1 through 1-5, Table 2, Table 3, Tables 4-1 through 4-23, and Table 5.	For Components included within a time-based maintenance program, the entity failed to maintain more than 10% but 15% or less of the total Components included within a specific Component Type in accordance with the minimum maintenance activities and maximum maintenance intervals prescribed within Tables 1-1 through 1-5, Table 2, Table 3, Tables 4-1 through 4-23, and Table 5.	For Components included within a time-based maintenance program, the entity failed to maintain more than 15% of the total Components included within a specific Component Type in accordance with the minimum maintenance activities and maximum maintenance intervals prescribed within Tables 1-1 through 1-5, Table 2, Table 3, Tables 4-1 through 4-23, and Table 5.

Requirement Number	Lower VSL	Moderate VSL	High VSL	Severe VSL
R4	For Components included within a performance-based maintenance program, the entity failed to maintain 5% or less of the annual scheduled maintenance for a specific Component Type in accordance with their performance-based PSMP.	For Components included within a performance-based maintenance program, the entity failed to maintain more than 5% but 10% or less of the annual scheduled maintenance for a specific Component Type in accordance with their performance-based PSMP.	For Components included within a performance-based maintenance program, the entity failed to maintain more than 10% but 15% or less of the annual scheduled maintenance for a specific Component Type in accordance with their performance-based PSMP.	For Components included within a performance-based maintenance program, the entity failed to maintain more than 15% of the annual scheduled maintenance for a specific Component Type in accordance with their performance-based PSMP.
R5	The entity failed to undertake efforts to correct 5 or fewer identified Unresolved Maintenance Issues.	The entity failed to undertake efforts to correct greater than 5 but less than or equal to 10 identified Unresolved Maintenance Issues.	The entity failed to undertake efforts to correct greater than 10 but less than or equal to 15 identified Unresolved Maintenance Issues.	The entity failed to undertake efforts to correct greater than 15 identified Unresolved Maintenance Issues.

D. Regional Variances

None.

E. Interpretations

None.

Supplemental Reference Documents

The following documents present a detailed discussion about determination of maintenance intervals and other useful information regarding establishment of a maintenance program.

1. *Supplementary Reference and FAQ - PRC-005-~~4~~ Protection System Maintenance*, Protection System Maintenance and Testing Standard Drafting Team (April 201~~5~~4)
2. *Considerations for Maintenance and Testing of Auto-reclosing Schemes*, NERC System Analysis and Modeling Subcommittee, and NERC System Protection and Control Subcommittee (November 2012)
3. *Sudden Pressure Relays and Other Devices that Respond to Non-Electrical Quantities – SPCS Input for Standard Development in Response to FERC Order No. 758*, NERC System Protection and Control Subcommittee (December 2013)
4. *Sudden Pressure Relays and Other Devices that Respond to Non-Electrical Quantities – Supplemental Information to Support Project 2007-17.3: Protection System Maintenance and Testing* (October 31, 2014)

Version History

Version	Date	Action	Change Tracking
0	February 8, 2005	Adopted by NERC Board of Trustees	New.
1	February 7, 2006	Adopted by NERC Board of Trustees	<ol style="list-style-type: none"> 1. Changed incorrect use of certain hyphens (-) to “en dash” (–) and “em dash (—).” 2. Added “periods” to items where appropriate. Changed “Timeframe” to “Time Frame” in item D, 1.2.
1a	February 17, 2011	Adopted by NERC Board of Trustees	Added Appendix 1 - Interpretation regarding applicability of standard to protection of radially connected transformers developed in Project 2009-17.
1b	November 5,	Adopted by NERC Board of	Interpretation of R1, R1.1, and

Version	Date	Action	Change Tracking
	2009	Trustees	R1.2 developed by Project 2009-10.
1b	February 3, 2012	FERC Order approving revised definition of “Protection System”	Per footnote 8 of FERC’s order, the definition of “Protection System” supersedes interpretation “b” of PRC-005-1b upon the effective date of the modified definition (i.e., April 1, 2013). <i>See N. Amer. Elec. Reliability Corp., 138 FERC ¶ 61,095 (February 3, 2012).</i>
1.1b	May 9, 2012	Adopted by NERC Board of Trustees	Errata change developed by Project 2010-07, clarified inclusion of generator interconnection Facility in Generator Owner’s responsibility.
2	November 7, 2012	Adopted by NERC Board of Trustees	Project 2007-17 - Complete revision, absorbing maintenance requirements from PRC-005-1.1b, PRC-008-0, PRC-011-0, PRC-017-0.
2	October 17, 2013	Approved by NERC Standards Committee	Errata Change: The Standards Committee approved an errata change to the implementation plan for PRC-005-2 to add the phrase “or as otherwise made effective pursuant to the laws applicable to such ERO governmental authorities;” to the second sentence under the “Retirement of Existing Standards” section. (no change to standard version number)
2	March 7, 2014	Adopted by NERC Board of Trustees	Modified R1 VSL in response to FERC directive (no change to standard version number).
2(i)	November 13, 2014	Adopted by NERC Board of Trustees	Applicability section revised by Project 2014-01 to clarify application of Requirements to BES dispersed power producing resources.

Version	Date	Action	Change Tracking
2(ii)	November 13, 2014	Adopted by NERC Board of Trustees	Replaced references to Special Protection System and SPS with Remedial Action Scheme and RAS.
3	November 7, 2013	Adopted by the NERC Board of Trustees	Revised to address the FERC directive in Order No. 758 to include Automatic Reclosing in maintenance programs.
3	February 12, 2014	Approved by NERC Standards Committee	Errata Change: The Standards Committee approved errata changes to correct capitalization of certain defined terms within the definitions of “Unresolved Maintenance Issue” and “Protection System Maintenance Program”. The changes will be reflected in the definitions section of PRC-005-3 for “Unresolved Maintenance Issue” and in the NERC Glossary of Terms for “Protection System Maintenance Program”. (no change to standard version number)
3	March 7, 2014	Adopted by NERC Board of Trustees	Modified R1 VSL in response to FERC directive (no change to standard version number).
3(i)	November 13, 2014	Adopted by NERC Board of Trustees	Applicability section revised by Project 2014-01 to clarify application of Requirements to BES dispersed power producing resources.
3(ii)	November 13, 2014	Adopted by NERC Board of Trustees	Replaced references to Special Protection System and SPS with Remedial Action Scheme and RAS.
4	November 13, 2014	Adopted by NERC Board of Trustees	Added Sudden Pressure Relaying in response to FERC Order No. 758.
5	TBD		Applicability section revised by Project 2014-01 to clarify application of Requirements to

Version	Date	Action	Change Tracking
			BES dispersed power producing resources.
<u>6</u>	<u>TBD</u>		<u>Revised to add supervisory relays to Automatic Reclosing in accordance with the directives in FERC Order 803.</u>

Table 1-1 Component Type - Protective Relay Excluding distributed UFLS and distributed UVLS (see Table 3)		
Component Attributes	Maximum Maintenance Interval ³	Maintenance Activities
Any unmonitored protective relay not having all the monitoring attributes of a category below.	6 Calendar Years	For all unmonitored relays: <ul style="list-style-type: none"> • Verify that settings are as specified For non-microprocessor relays: <ul style="list-style-type: none"> • Test and, if necessary calibrate For microprocessor relays: <ul style="list-style-type: none"> • Verify operation of the relay inputs and outputs that are essential to proper functioning of the Protection System. • Verify acceptable measurement of power system input values.
Monitored microprocessor protective relay with the following: <ul style="list-style-type: none"> • Internal self-diagnosis and alarming (see Table 2). • Voltage and/or current waveform sampling three or more times per power cycle, and conversion of samples to numeric values for measurement calculations by microprocessor electronics. • Alarming for power supply failure (see Table 2). 	12 Calendar Years	Verify: <ul style="list-style-type: none"> • Settings are as specified. • Operation of the relay inputs and outputs that are essential to proper functioning of the Protection System. • Acceptable measurement of power system input values.

³ For the tables in this standard, a calendar year starts on the first day of a new year (January 1) after a maintenance activity has been completed. For the tables in this standard, a calendar month starts on the first day of the first month after a maintenance activity has been completed.

Table 1-1 Component Type - Protective Relay Excluding distributed UFLS and distributed UVLS (see Table 3)		
Component Attributes	Maximum Maintenance Interval ³	Maintenance Activities
Monitored microprocessor protective relay with preceding row attributes and the following: <ul style="list-style-type: none"> • Ac measurements are continuously verified by comparison to an independent ac AC measurement source, with alarming for excessive error (See Table 2). • Some or all binary or status inputs and control outputs are monitored by a process that continuously demonstrates ability to perform as designed, with alarming for failure (See Table 2). • Alarming for change of settings (See Table 2). 	12 Calendar Years	Verify only the unmonitored relay inputs and outputs that are essential to proper functioning of the Protection System.

Table 1-2 Component Type - Communications Systems Excluding distributed UFLS and distributed UVLS (see Table 3)		
Component Attributes	Maximum Maintenance Interval	Maintenance Activities
Any unmonitored communications system necessary for correct operation of protective functions, and not having all the monitoring attributes of a category below.	4 Calendar Months	Verify that the communications system is functional.
	6 Calendar Years	Verify that the communications system meets performance criteria pertinent to the communications technology applied (e.g. signal level, reflected power, or data error rate). Verify operation of communications system inputs and outputs that are essential to proper functioning of the Protection System.
Any communications system with continuous monitoring or periodic automated testing for the presence of the channel function, and alarming for loss of function (See Table 2).	12 Calendar Years	Verify that the communications system meets performance criteria pertinent to the communications technology applied (e.g. signal level, reflected power, or data error rate). Verify operation of communications system inputs and outputs that are essential to proper functioning of the Protection System.
Any communications system with all of the following: <ul style="list-style-type: none"> • Continuous monitoring or periodic automated testing for the performance of the channel using criteria pertinent to the communications technology applied (e.g. signal level, reflected power, or data error rate, and alarming for excessive performance degradation). (See Table 2) • Some or all binary or status inputs and control outputs are monitored by a process that continuously demonstrates ability to perform as designed, with alarming for failure (See Table 2). 	12 Calendar Years	Verify only the unmonitored communications system inputs and outputs that are essential to proper functioning of the Protection System

Table 1-3 Component Type - Voltage and Current Sensing Devices Providing Inputs to Protective Relays Excluding distributed UFLS and distributed UVLS (see Table 3)		
Component Attributes	Maximum Maintenance Interval	Maintenance Activities
Any voltage and current sensing devices not having monitoring attributes of the category below.	12 Calendar Years	Verify that current and voltage signal values are provided to the protective relays.
Voltage and Current Sensing devices connected to microprocessor relays with AC measurements <u>that</u> are continuously verified by comparison of sensing input value, as measured by the microprocessor relay, to an independent <u>AC</u> measurement source, with alarming for unacceptable error or failure (see Table 2).	No periodic maintenance specified	None.

Table 1-4(a) Component Type – Protection System Station d e-DC Supply Using Vented Lead-Acid (VLA) Batteries Excluding distributed UFLS and distributed UVLS (see Table 3)		
Protection System Station d e-DC supply used only for non-BES interrupting devices for RAS, non-distributed UFLS systems, or non-distributed UVLS systems is excluded (see Table 1-4(e)).		
Component Attributes	Maximum Maintenance Interval	Maintenance Activities
Protection System Station d e-DC supply using Vented Lead-Acid (VLA) batteries not having monitoring attributes of Table 1-4(f).	4 Calendar Months	Verify: <ul style="list-style-type: none"> • Station de-DC supply voltage Inspect: <ul style="list-style-type: none"> • Electrolyte level • For unintentional grounds
	18 Calendar Months	Verify: <ul style="list-style-type: none"> • Float voltage of battery charger • Battery continuity • Battery terminal connection resistance • Battery intercell or unit-to-unit connection resistance Inspect: <ul style="list-style-type: none"> • Cell condition of all individual battery cells where cells are visible – or measure battery cell/unit internal ohmic values where the cells are not visible • Physical condition of battery rack

Table 1-4(a) Component Type – Protection System Station dc -DC Supply Using Vented Lead-Acid (VLA) Batteries Excluding distributed UFLS and distributed UVLS (see Table 3)		
Protection System Station dc -DC supply used only for non-BES interrupting devices for RAS, non-distributed UFLS systems, or non-distributed UVLS systems is excluded (see Table 1-4(e)).		
Component Attributes	Maximum Maintenance Interval	Maintenance Activities
	18 Calendar Months -or- 6 Calendar Years	Verify that the station battery can perform as manufactured by evaluating cell/unit measurements indicative of battery performance (e.g. internal ohmic values or float current) against the station battery baseline. -or- Verify that the station battery can perform as manufactured by conducting a performance or modified performance capacity test of the entire battery bank.

Table 1-4(b) Component Type – Protection System Station dc DC Supply Using Valve-Regulated Lead-Acid (VRLA) Batteries Excluding distributed UFLS and distributed UVLS (see Table 3)		
Protection System Station dc DC supply used only for non-BES interrupting devices for RAS, non-distributed UFLS systems, or non-distributed UVLS systems is excluded (see Table 1-4(e)).		
Component Attributes	Maximum Maintenance Interval	Maintenance Activities
Protection System Station dc DC supply with Valve Regulated Lead-Acid (VRLA) batteries not having monitoring attributes of Table 1-4(f).	4 Calendar Months	Verify: <ul style="list-style-type: none"> • Station dcDC supply voltage Inspect: <ul style="list-style-type: none"> • For unintentional grounds
	6 Calendar Months	Inspect: <ul style="list-style-type: none"> • Condition of all individual units by measuring battery cell/unit internal ohmic values.
	18 Calendar Months	Verify: <ul style="list-style-type: none"> • Float voltage of battery charger • Battery continuity • Battery terminal connection resistance • Battery intercell or unit-to-unit connection resistance Inspect: <ul style="list-style-type: none"> • Physical condition of battery rack

Table 1-4(b) Component Type – Protection System Station dc DC Supply Using Valve-Regulated Lead-Acid (VRLA) Batteries Excluding distributed UFLS and distributed UVLS (see Table 3)		
Protection System Station dc DC supply used only for non-BES interrupting devices for RAS, non-distributed UFLS systems, or non-distributed UVLS systems is excluded (see Table 1-4(e)).		
Component Attributes	Maximum Maintenance Interval	Maintenance Activities
	6 Calendar Months -or- 3 Calendar Years	Verify that the station battery can perform as manufactured by evaluating cell/unit measurements indicative of battery performance (e.g. internal ohmic values or float current) against the station battery baseline. -or- Verify that the station battery can perform as manufactured by conducting a performance or modified performance capacity test of the entire battery bank.

Table 1-4(c) Component Type – Protection System Station 4e-DC Supply Using Nickel-Cadmium (NiCad) Batteries Excluding distributed UFLS and distributed UVLS (see Table 3)		
Protection System Station 4e-DC supply used only for non-BES interrupting devices for RAS, non-distributed UFLS system, or non-distributed UVLS systems is excluded (see Table 1-4(e)).		
Component Attributes	Maximum Maintenance Interval	Maintenance Activities
Protection System Station 4e-DC supply Nickel-Cadmium (NiCad) batteries not having monitoring attributes of Table 1-4(f).	4 Calendar Months	Verify: <ul style="list-style-type: none"> • Station 4e-DC supply voltage Inspect: <ul style="list-style-type: none"> • Electrolyte level • For unintentional grounds
	18 Calendar Months	Verify: <ul style="list-style-type: none"> • Float voltage of battery charger • Battery continuity • Battery terminal connection resistance • Battery intercell or unit-to-unit connection resistance Inspect: <ul style="list-style-type: none"> • Cell condition of all individual battery cells. • Physical condition of battery rack

Table 1-4(c) Component Type – Protection System Station dc-DC Supply Using Nickel-Cadmium (NiCad) Batteries Excluding distributed UFLS and distributed UVLS (see Table 3)		
Protection System Station dc-DC supply used only for non-BES interrupting devices for RAS, non-distributed UFLS system, or non-distributed UVLS systems is excluded (see Table 1-4(e)).		
Component Attributes	Maximum Maintenance Interval	Maintenance Activities
	6 Calendar Years	Verify that the station battery can perform as manufactured by conducting a performance or modified performance capacity test of the entire battery bank.

Table 1-4(d) Component Type – Protection System Station dc -DC Supply Using Non Battery Based Energy Storage Excluding distributed UFLS and distributed UVLS (see Table 3)		
Protection System Station dc -DC supply used only for non-BES interrupting devices for RAS, non-distributed UFLS system, or non-distributed UVLS systems is excluded (see Table 1-4(e)).		
Component Attributes	Maximum Maintenance Interval	Maintenance Activities
Any Protection System station dc -DC supply not using a battery and not having monitoring attributes of Table 1-4(f).	4 Calendar Months	Verify: <ul style="list-style-type: none"> • Station dc-DC supply voltage Inspect: <ul style="list-style-type: none"> • For unintentional grounds
	18 Calendar Months	Inspect: Condition of non-battery based dc -DC supply
	6 Calendar Years	Verify that the dc -DC supply can perform as manufactured when ac AC power is not present.

Table 1-4(e) Component Type – Protection System Station de-DC Supply for non-BES Interrupting Devices for RAS, non-distributed UFLS, and non-distributed UVLS systems		
Component Attributes	Maximum Maintenance Interval	Maintenance Activities
Any Protection System de-DC supply used for tripping only non-BES interrupting devices as part of a RAS, non-distributed UFLS, or non-distributed UVLS system and not having monitoring attributes of Table 1-4(f).	When control circuits are verified (See Table 1-5)	Verify Station de-DC supply voltage.

Table 1-4(f) Exclusions for Protection System Station e-DC Supply Monitoring Devices and Systems		
Component Attributes	Maximum Maintenance Interval	Maintenance Activities
Any station e-DC supply with high and low voltage monitoring and alarming of the battery charger voltage to detect charger overvoltage and charger failure (See Table 2).	No periodic maintenance specified	No periodic verification of station e-DC supply voltage is required.
Any battery based station e-DC supply with electrolyte level monitoring and alarming in every cell (See Table 2).		No periodic inspection of the electrolyte level for each cell is required.
Any station e-DC supply with unintentional e-DC ground monitoring and alarming (See Table 2).		No periodic inspection of unintentional e-DC grounds is required.
Any station e-DC supply with charger float voltage monitoring and alarming to ensure correct float voltage is being applied on the station e-DC supply (See Table 2).		No periodic verification of float voltage of battery charger is required.
Any battery based station e-DC supply with monitoring and alarming of battery string continuity (See Table 2).		No periodic verification of the battery continuity is required.
Any battery based station e-DC supply with monitoring and alarming of the intercell and/or terminal connection detail resistance of the entire battery (See Table 2).		No periodic verification of the intercell and terminal connection resistance is required.
Any Valve Regulated Lead-Acid (VRLA) or Vented Lead-Acid (VLA) station battery with internal ohmic value or float current monitoring and alarming, and evaluating present values relative to baseline internal ohmic values for every cell/unit (See Table 2).		No periodic evaluation relative to baseline of battery cell/unit measurements indicative of battery performance is required to verify the station battery can perform as manufactured.
Any Valve Regulated Lead-Acid (VRLA) or Vented Lead-Acid (VLA) station battery with monitoring and alarming of each cell/unit internal ohmic value (See Table 2).		No periodic inspection of the condition of all individual units by measuring battery cell/unit internal ohmic values of a station VRLA or Vented Lead-Acid (VLA) battery is required.

Table 1-5 Component Type - Control Circuitry Associated With Protective Functions Excluding distributed UFLS and distributed UVLS (see Table 3), Automatic Reclosing (see Table 4), and Sudden Pressure Relaying (see Table 5) Note: Table requirements apply to all Control Circuitry Components of Protection Systems, and RAS except as noted.		
Component Attributes	Maximum Maintenance Interval	Maintenance Activities
Trip coils or actuators of circuit breakers, interrupting devices, or mitigating devices (regardless of any monitoring of the control circuitry).	6 Calendar Years	Verify that each trip coil is able to operate the circuit breaker, interrupting device, or mitigating device.
Electromechanical lockout devices which are directly in a trip path from the protective relay to the interrupting device trip coil (regardless of any monitoring of the control circuitry).	6 Calendar Years	Verify electrical operation of electromechanical lockout devices.
Unmonitored control circuitry associated with RAS. (See Table 4-2(b) for RAS which include Automatic Reclosing.)	12 Calendar Years	Verify all paths of the control circuits essential for proper operation of the RAS.
Unmonitored control circuitry associated with protective functions inclusive of all auxiliary relays.	12 Calendar Years	Verify all paths of the trip circuits inclusive of all auxiliary relays through the trip coil(s) of the circuit breakers or other interrupting devices.
Control circuitry associated with protective functions and/or RAS whose integrity is monitored and alarmed (See Table 2).	No periodic maintenance specified	None.

Table 2 – Alarming Paths and Monitoring In Tables 1-1 through 1-5, Table 3, Tables 4-1 through 4-23, and Table 5 alarm attributes used to justify extended maximum maintenance intervals and/or reduced maintenance activities are subject to the following maintenance requirements		
Component Attributes	Maximum Maintenance Interval	Maintenance Activities
Any alarm path through which alarms in Tables 1-1 through 1-5, Table 3, Tables 4-1 through 4-23, and Table 5 are conveyed from the alarm origin to the location where corrective action can be initiated, and not having all the attributes of the “Alarm Path with monitoring” category below. Alarms are reported within 24 hours of detection to a location where corrective action can be initiated.	12 Calendar Years	Verify that the alarm path conveys alarm signals to a location where corrective action can be initiated.
Alarm Path with monitoring: The location where corrective action is taken receives an alarm within 24 hours for failure of any portion of the alarming path from the alarm origin to the location where corrective action can be initiated.	No periodic maintenance specified	None.

Table 3 Maintenance Activities and Intervals for distributed UFLS and distributed UVLS Systems		
Component Attributes	Maximum Maintenance Interval	Maintenance Activities
Any unmonitored protective relay not having all the monitoring attributes of a category below.	6 Calendar Years	<p>Verify that settings are as specified.</p> <p>For non-microprocessor relays:</p> <ul style="list-style-type: none"> • Test and, if necessary calibrate. <p>For microprocessor relays:</p> <ul style="list-style-type: none"> • Verify operation of the relay inputs and outputs that are essential to proper functioning of the Protection System. • Verify acceptable measurement of power system input values.
<p>Monitored microprocessor protective relay with the following:</p> <ul style="list-style-type: none"> • Internal self-diagnosis and alarming (See Table 2). • Voltage and/or current waveform sampling three or more times per power cycle, and conversion of samples to numeric values for measurement calculations by microprocessor electronics. <p>Alarming for power supply failure (See Table 2).</p>	12 Calendar Years	<p>Verify:</p> <ul style="list-style-type: none"> • Settings are as specified. • Operation of the relay inputs and outputs that are essential to proper functioning of the Protection System. • Acceptable measurement of power system input values.
<p>Monitored microprocessor protective relay with preceding row attributes and the following:</p> <ul style="list-style-type: none"> • Ac measurements are continuously verified by comparison to an independent ac AC measurement source, with alarming for excessive error (See Table 2). • Some or all binary or status inputs and control outputs are monitored by a process that continuously demonstrates ability to perform as 	12 Calendar Years	<p>Verify only the unmonitored relay inputs and outputs that are essential to proper functioning of the Protection System.</p>

Table 3 Maintenance Activities and Intervals for distributed UFLS and distributed UVLS Systems		
Component Attributes	Maximum Maintenance Interval	Maintenance Activities
designed, with alarming for failure (See Table 2). Alarming for change of settings (See Table 2).		
Voltage and/or current sensing devices associated with UFLS or UVLS systems.	12 Calendar Years	Verify that current and/or voltage signal values are provided to the protective relays.
Protection System dc -DC supply for tripping non-BES interrupting devices used only for a UFLS or UVLS system.	12 Calendar Years	Verify Protection System dc -DC supply voltage.
Control circuitry between the UFLS or UVLS relays and electromechanical lockout and/or tripping auxiliary devices (excludes non-BES interrupting device trip coils).	12 Calendar Years	Verify the path from the relay to the lockout and/or tripping auxiliary relay (including essential supervisory logic).
Electromechanical lockout and/or tripping auxiliary devices associated only with UFLS or UVLS systems (excludes non-BES interrupting device trip coils).	12 Calendar Years	Verify electrical operation of electromechanical lockout and/or tripping auxiliary devices.
Control circuitry between the electromechanical lockout and/or tripping auxiliary devices and the non-BES interrupting devices in UFLS or UVLS systems, or between UFLS or UVLS relays (with no interposing electromechanical lockout or auxiliary device) and the non-BES interrupting devices (excludes non-BES interrupting device trip coils).	No periodic maintenance specified	None.
Trip coils of non-BES interrupting devices in UFLS or UVLS systems.	No periodic maintenance specified	None.

Table 4-1 Maintenance Activities and Intervals for Automatic Reclosing Components Component Type – Reclosing <u>and Supervisory</u> Relay		
Note: In cases where Components of Automatic Reclosing are common to Components listed in Table 1-1 through 1-5, the Components only need to be tested once during a distinct maintenance interval.		
Component Attributes	Maximum Maintenance Interval	Maintenance Activities
Any unmonitored reclosing relay <u>or supervisory relay</u> not having all the monitoring attributes of a category below.	6 Calendar Years	Verify that settings are as specified. For non-microprocessor relays: <ul style="list-style-type: none"> • Test and, if necessary calibrate For microprocessor relays: <ul style="list-style-type: none"> • <u>Verify operation of the relay inputs and outputs that are essential to proper functioning of the Automatic Reclosing.</u> <u>For microprocessor supervisory relays:</u> <ul style="list-style-type: none"> • <u>Verify acceptable measurement of power system input values.</u>
Monitored microprocessor reclosing relay <u>or supervisory relay</u> with the following: <ul style="list-style-type: none"> • Internal self-diagnosis and alarming (See Table 2). • <u>Alarming for power supply failure (See Table 2).</u> <u>For supervisory relay:</u> <ul style="list-style-type: none"> • <u>Voltage waveform sampling three or more times per power cycle, and conversion of samples to numeric values for measurement calculations by microprocessor electronics.</u> 	12 Calendar Years	Verify: <ul style="list-style-type: none"> • Settings are as specified. Operation of the relay inputs and outputs that are essential to proper functioning of the Automatic Reclosing. <u>For supervisory relays:</u> <ul style="list-style-type: none"> • <u>Verify acceptable measurement of power system input values.</u>

Table 4-1

Maintenance Activities and Intervals for Automatic Reclosing Components

Component Type – Reclosing and Supervisory Relay

Note: In cases where Components of Automatic Reclosing are common to Components listed in Table 1-1 through 1-5, the Components only need to be tested once during a distinct maintenance interval.

<u>Component Attributes</u>	<u>Maximum Maintenance Interval</u>	<u>Maintenance Activities</u>
<p><u>Monitored microprocessor reclosing relay or supervisory relay with preceding row attributes and the following:</u></p> <ul style="list-style-type: none"> • <u>Some or all binary or status inputs and control outputs are monitored by a process that continuously demonstrates ability to perform as designed, with alarming for failure (See Table 2).</u> • <u>Alarming for change of settings (See Table 2).</u> <p><u>For supervisory relay:</u></p> <ul style="list-style-type: none"> • <u>AC measurements are continuously verified by comparison to an independent AC measurement source, with alarming for excessive error (See Table 2).</u> 	<p><u>12 Calendar Years</u></p>	<p><u>Verify only the unmonitored relay inputs and outputs that are essential to proper functioning of the Automatic Reclosing.</u></p>

Table 4-2(a) Maintenance Activities and Intervals for Automatic Reclosing Components Component Type – Control Circuitry Associated with Reclosing <u>and Supervisory</u> Relays that are NOT an Integral Part of an RAS		
Component Attributes	Maximum Maintenance Interval	Maintenance Activities
Unmonitored Control circuitry associated with Automatic Reclosing that is not an integral part of an RAS.	12 Calendar Years	Verify that Automatic Reclosing, upon initiation, does not issue a premature closing command to the close circuitry.
Control circuitry associated with Automatic Reclosing that is not part of an RAS and is monitored and alarmed for conditions that would result in a premature closing command. (See Table 2)	No periodic maintenance specified	None.

Table 4-2(b) Maintenance Activities and Intervals for Automatic Reclosing Components Component Type – Control Circuitry Associated with Reclosing and Supervisory Relays that ARE an Integral Part of an RAS		
Component Attributes	Maximum Maintenance Interval	Maintenance Activities
Close coils or actuators of circuit breakers or similar devices that are used in conjunction with Automatic Reclosing as part of an RAS (regardless of any monitoring of the control circuitry).	6 Calendar Years	Verify that each close coil or actuator is able to operate the circuit breaker or mitigating device.
Unmonitored close control circuitry associated with Automatic Reclosing used as an integral part of an RAS.	12 Calendar Years	Verify all paths of the control circuits associated with Automatic Reclosing that are essential for proper operation of the RAS.
Control circuitry associated with Automatic Reclosing that is an integral part of an RAS whose integrity is monitored and alarmed. (See Table 2)	No periodic maintenance specified	None.

Table 4-3 Maintenance Activities and Intervals for Automatic Reclosing Components Component Type – Voltage Sensing Devices Associated with Supervisory Relays		
<u>Component Attributes</u>	<u>Maximum Maintenance Interval</u>	<u>Maintenance Activities</u>
<u>Any voltage sensing devices not having monitoring attributes of the category below.</u>	<u>12 Calendar Years</u>	<u>Verify that voltage signal values are provided to the supervisory relays.</u>
<u>Voltage sensing devices that are connected to microprocessor supervisory relays with AC measurements that are continuously verified by comparison of sensing input value, as measured by the microprocessor relay, to an independent AC measurement source, with alarming for unacceptable error or failure. (See Table 2)</u>	<u>No periodic maintenance specified</u>	<u>None.</u>

<p style="text-align: center;">Table 5</p> <p style="text-align: center;">Maintenance Activities and Intervals for Sudden Pressure Relaying</p> <p style="text-align: center;">Note: In cases where Components of Sudden Pressure Relaying are common to Components listed in Table 1-5, the Components only need to be tested once during a distinct maintenance interval.</p>		
Component Attributes	Maximum Maintenance Interval	Maintenance Activities
Any fault pressure relay.	6 Calendar Years	Verify the pressure or flow sensing mechanism is operable.
Electromechanical lockout devices which are directly in a trip path from the fault pressure relay to the interrupting device trip coil (regardless of any monitoring of the control circuitry).	6 Calendar Years	Verify electrical operation of electromechanical lockout devices.
Unmonitored control circuitry associated with Sudden Pressure Relaying.	12 Calendar Years	Verify all paths of the trip circuits inclusive of all auxiliary relays through the trip coil(s) of the circuit breakers or other interrupting devices.
Control circuitry associated with Sudden Pressure Relaying whose integrity is monitored and alarmed (See Table 2).	No periodic maintenance specified	None.

PRC-005 — Attachment A

Criteria for a Performance-Based Protection System Maintenance Program

Purpose: To establish a technical basis for initial and continued use of a performance-based Protection System Maintenance Program (PSMP).

To establish the technical justification for the initial use of a performance-based PSMP:

1. Develop a list with a description of Components included in each designated Segment, with a minimum Segment population of 60 Components.
2. Maintain the Components in each Segment according to the time-based maximum allowable intervals established in Tables 1-1 through 1-5, Table 3, Tables 4-1 through 4-~~32~~, and Table 5 until results of maintenance activities for the Segment are available for a minimum of 30 individual Components of the Segment.
3. Document the maintenance program activities and results for each Segment, including maintenance dates and Countable Events for each included Component.
4. Analyze the maintenance program activities and results for each Segment to determine the overall performance of the Segment and develop maintenance intervals.
5. Determine the maximum allowable maintenance interval for each Segment such that the Segment experiences Countable Events on no more than 4% of the Components within the Segment, for the greater of either the last 30 Components maintained or all Components maintained in the previous year.

To maintain the technical justification for the ongoing use of a performance-based PSMP:

1. At least annually, update the list of Components and Segments and/or description if any changes occur within the Segment.
2. Perform maintenance on the greater of 5% of the Components (addressed in the performance based PSMP) in each Segment or 3 individual Components within the Segment in each year.
3. For the prior year, analyze the maintenance program activities and results for each Segment to determine the overall performance of the Segment.
4. Using the prior year's data, determine the maximum allowable maintenance interval for each Segment such that the Segment experiences Countable Events on no more than 4% of the Components within the Segment, for the greater of either the last 30 Components maintained or all Components maintained in the previous year.

If the Components in a Segment maintained through a performance-based PSMP experience 4% or more Countable Events, develop, document, and implement an action plan to reduce the Countable Events to less than 4% of the Segment population within 3 years.

Rationale:

During development of this standard, text boxes were embedded within the standard to explain the rationale for various parts of the standard. Upon BOT approval, the text from the rationale text boxes was moved to this section.

Violation Risk Factor and Violation Severity Level Justifications

Project 2007-17.4 PRC-005-6

Protection System, Automatic Reclosing and Sudden Pressure Relaying Maintenance

Violation Risk Factor and Violation Severity Level Justifications

This document provides the drafting team's justification for assignment of violation risk factors (VRFs) and violation severity levels (VSLs) for each requirement in PRC-005-6 - Protection System, Automatic Reclosing and Sudden Pressure Relaying Maintenance.

Each primary requirement is assigned a VRF and a set of one or more VSLs. These elements support the determination of an initial value range for the Base Penalty Amount regarding violations of requirements in FERC-approved Reliability Standards, as defined in the ERO Sanction Guidelines.

The Protection System Maintenance and Testing Standard Drafting Team applied the following NERC criteria and FERC Guidelines when proposing VRFs and VSLs for the requirements under this project:

NERC Criteria – VRFs

High Risk Requirement

A requirement that, if violated, could directly cause or contribute to bulk electric system instability, separation, or a cascading sequence of failures, or could place the bulk electric system at an unacceptable risk of instability, separation, or cascading failures; or, a requirement in a planning time frame that, if violated, could, under emergency, abnormal, or restorative conditions anticipated by the preparations, directly cause or contribute to bulk electric system instability, separation, or a cascading sequence of failures, or could place the bulk electric system at an unacceptable risk of instability, separation, or cascading failures, or could hinder restoration to a normal condition.

Medium Risk Requirement

A requirement that, if violated, could directly affect the electrical state or the capability of the bulk electric system, or the ability to effectively monitor and control the bulk electric system. However, violation of a medium risk requirement is unlikely to lead to bulk electric system instability, separation, or cascading failures; or, a requirement in a planning time frame that, if violated, could, under emergency, abnormal, or restorative conditions anticipated by the preparations, directly and adversely affect the electrical state or capability of the bulk electric system, or the ability to effectively monitor, control, or restore the bulk electric system. However, violation of a medium risk requirement is unlikely, under emergency, abnormal, or restoration conditions anticipated by the

preparations, to lead to bulk electric system instability, separation, or cascading failures, nor to hinder restoration to a normal condition.

Lower Risk Requirement

A requirement that is administrative in nature and a requirement that, if violated, would not be expected to adversely affect the electrical state or capability of the bulk electric system, or the ability to effectively monitor and control the bulk electric system; or, a requirement that is administrative in nature and a requirement in a planning time frame that, if violated, would not, under the emergency, abnormal, or restorative conditions anticipated by the preparations, be expected to adversely affect the electrical state or capability of the bulk electric system, or the ability to effectively monitor, control, or restore the bulk electric system. A planning requirement that is administrative in nature.

FERC VRF Guidelines

Guideline (1) — Consistency with the Conclusions of the Final Blackout Report

The Commission seeks to ensure that VRFs assigned to Requirements of Reliability Standards in these identified areas appropriately reflect their historical critical impact on the reliability of the Bulk-Power System.

In the VSL Order, FERC listed critical areas (from the Final Blackout Report) where violations could severely affect the reliability of the Bulk-Power System:

- Emergency operations
- Vegetation management
- Operator personnel training
- Protection systems and their coordination
- Operating tools and backup facilities
- Reactive power and voltage control
- System modeling and data exchange
- Communication protocol and facilities
- Requirements to determine equipment ratings
- Synchronized data recorders
- Clearer criteria for operationally critical facilities
- Appropriate use of transmission loading relief

Guideline (2) — Consistency within a Reliability Standard

The Commission expects a rational connection between the sub-Requirement VRF assignments and the main Requirement VRF assignment.

Guideline (3) — Consistency among Reliability Standards

The Commission expects the assignment of VRFs corresponding to Requirements that address similar reliability goals in different Reliability Standards would be treated comparably.

Guideline (4) — Consistency with NERC's Definition of the VRF Level

Guideline (4) was developed to evaluate whether the assignment of a particular VRF level conforms to NERC's definition of that risk level.

Guideline (5) — Treatment of Requirements that Co-mingle More Than One Obligation

Where a single Requirement co-mingles a higher risk reliability objective and a lesser risk reliability objective, the VRF assignment for such Requirements must not be watered down to reflect the lower risk level associated with the less important objective of the Reliability Standard.

The following discussion addresses how the SDT considered FERC's VRF Guidelines 2 through 5. The team did not address Guideline 1 directly because of an apparent conflict between Guidelines 1 and 4. Whereas Guideline 1 identifies a list of topics that encompass nearly all topics within NERC's Reliability Standards and implies that these requirements should be assigned a "High" VRF, Guideline 4 directs assignment of VRFs based on the impact of a specific requirement to the reliability of the system. The SDT believes that Guideline 4 is reflective of the intent of VRFs in the first instance and therefore concentrated its approach on the reliability impact of the requirements.

PRC-005-6 Protection System, Automatic Reclosing and Sudden Pressure Relaying Maintenance is a revision of PRC-005-3 Protection System and Automatic Reclosing Maintenance with the stated purpose: To document and implement programs for the maintenance of all Protection Systems, Automatic Reclosing, and Sudden Pressure Relaying affecting the reliability of the Bulk Electric System (BES) so that they are kept in working order.

PRC-005-6 has five (5) requirements that address the inclusion of Sudden Pressure Relaying. A Table of minimum maintenance activities and maximum maintenance intervals for Sudden Pressure Relaying has been added to PRC-005-3 to address FERC's directives from Order 758. The revised standard requires that entities develop an appropriate Protection System Maintenance Program (PSMP), that they implement their PSMP, and that, in the event they are unable to restore Sudden Pressure Relaying Components to proper working order while performing maintenance, they initiate the follow-up activities necessary to resolve those maintenance issues.

The requirements of PRC-005-6 map one-to-one with the requirements of PRC-005-3. The drafting team did not revise the VRFs for the requirements of PRC-005-3.

PRC-005-6 Requirements R1 and R2 are related to developing and documenting a Protection System Maintenance Program. The Standard Drafting Team determined that the assignment of a VRF of Medium was consistent with the NERC criteria that violations of these requirements could directly affect the electrical state or the capability of the bulk electric system, or the ability to effectively monitor and control the bulk electric system but are unlikely to lead to bulk electric system instability, separation, or cascading failures. Additionally, a review of the body of existing NERC Standards with approved VRFs revealed that requirements with similar reliability objectives in other standards are largely assigned a VRF of Medium.

PRC-005-6 Requirements R3 and R4 are related to implementation of the Protection System Maintenance Program. The SDT determined that the assignment of a VRF of High was consistent with the NERC criteria that that violation of these requirements could directly cause or contribute to bulk electric system instability, separation, or a cascading sequence of failures, or could place the bulk electric system at an unacceptable risk of instability, separation, or cascading failures. Additionally, a review of the body of existing NERC Standards with approved VRFs revealed that requirements with similar reliability objectives in other standards are assigned a VRF of High.

PRC-005-6 Requirement R5 relates to the initiation of resolution of unresolved maintenance issues, which describe situations where an entity was unable to restore a Component to proper working order during the performance of the maintenance activity. The Standard Drafting Team determined that the assignment of a VRF of Medium was consistent with the NERC criteria that violation of this requirements could directly affect the electrical state or the capability of the bulk electric system, or the ability to effectively monitor and control the bulk electric system but are unlikely to lead to bulk electric system instability, separation, or cascading failures. Additionally, a review of the body of existing NERC Standards with approved VRFs revealed that requirements with similar reliability objectives in other standards are largely assigned a VRF of Medium.

NERC Criteria - VSLs

VSLs define the degree to which compliance with a requirement was not achieved. Each requirement must have at least one VSL. While it is preferable to have four VSLs for each requirement, some requirements do not have multiple “degrees” of noncompliant performance and may have only one, two, or three VSLs.

VSLs should be based on the guidelines shown in the table below:

Lower	Moderate	High	Severe
<p>Missing a minor element (or a small percentage) of the required performance</p> <p>The performance or product measured has significant value as it almost meets the full intent of the requirement.</p>	<p>Missing at least one significant element (or a moderate percentage) of the required performance.</p> <p>The performance or product measured still has significant value in meeting the intent of the requirement.</p>	<p>Missing more than one significant element (or is missing a high percentage) of the required performance or is missing a single vital Component.</p> <p>The performance or product has limited value in meeting the intent of the requirement.</p>	<p>Missing most or all of the significant elements (or a significant percentage) of the required performance.</p> <p>The performance measured does not meet the intent of the requirement or the product delivered cannot be used in meeting the intent of the requirement.</p>

FERC Order on VSLs

In its June 19, 2008 Order on VSLs, FERC indicated it would use the following four guidelines for determining whether to approve VSLs:

Guideline 1: VSL Assignments Should Not Have the Unintended Consequence of Lowering the Current Level of Compliance

- Compare the VSLs to any prior Levels of Non-compliance and avoid significant changes that may encourage a lower level of compliance than was required when Levels of Non-compliance were used.

Guideline 2: VSL Assignments Should Ensure Uniformity and Consistency in the Determination of Penalties

- Guideline 2a: A violation of a “binary” type requirement must be a “Severe” VSL.
- Guideline 2b: Do not use ambiguous terms such as “minor” and “significant” to describe noncompliant performance.

Guideline 3: VSL Assignment Should Be Consistent with the Corresponding Requirement

- VSLs should not expand on what is required in the requirement.

Guideline 4: VSL Assignment Should Be Based on A Single Violation, Not on A Cumulative Number of Violations

- . . . unless otherwise stated in the requirement, each instance of non-compliance with a requirement is a separate violation. Section 4 of the Sanction Guidelines states that assessing penalties on a per violation per day basis is the “default” for penalty calculations.

VRF and VSL Justifications

VRF and VSL Justifications – PRC-005-6, R1	
Proposed VRF	Medium
NERC VRF Discussion	Failure to establish a Protection System Maintenance Program (PSMP) for Protection Systems designed to provide protection for BES Element(s) could directly affect the electrical state or the capability of the bulk power system. However, violation of this requirement is unlikely to lead to bulk power system instability, separation, or cascading failures. The applicable entities are always responsible for maintaining the reliability of the bulk power system regardless of the situation. This VRF emphasizes the risk to system performance that results from mal-performing Protection System Components. Failure to establish a Protection System Maintenance Program (PSMP) for Protection Systems will not, by itself, lead to instability, separation, or cascading failures. Thus, the requirement meets NERC’s criteria for a Medium VRF.
FERC VRF G1 Discussion	Guideline 1- Consistency w/ Blackout Report: N/A
FERC VRF G2 Discussion	Guideline 2- Consistency within a Reliability Standard: The requirement has no sub-requirements so only one VRF was assigned. The requirement utilizes Parts to identify the items to be included within a Protection System Maintenance Program. The VRF for this requirement is consistent with others in the standard with regard to relative risk; therefore, there is no conflict.
FERC VRF G3 Discussion	Guideline 3- Consistency among Reliability Standards: The SDT has determined that there is no consistency among existing approved Standards relative to requirements of this nature. The SDT has assigned a MEDIUM VRF, which is consistent with recent FERC guidance on FAC-008-3 Requirement R2 and FAC-013-2 Requirement R1, which are similar in nature to PRC-005-6 Requirement R1.

VRF and VSL Justifications – PRC-005-6, R1			
Proposed VRF	Medium		
FERC VRF G4 Discussion	<p>Guideline 4- Consistency with NERC Definitions of VRFs:</p> <p>Failure to establish a Protection System Maintenance Program (PSMP) for Protection Systems designed to provide protection for BES Element(s) could directly affect the electrical state or the capability of the bulk power system. However, violation of this requirement is unlikely to lead to bulk power system instability, separation, or cascading failures. The applicable entities are always responsible for maintaining the reliability of the bulk power system regardless of the situation. This VRF emphasizes the risk to system performance that results from mal-performing Protection System Components. Failure to establish a Protection System Maintenance Program (PSMP) for Protection Systems will not, by itself, lead to instability, separation, or cascading failures. Thus, the requirement meets NERC’s criteria for a Medium VRF.</p>		
FERC VRF G5 Discussion	<p>Guideline 5- Treatment of Requirements that Co-mingle More than One Obligation:</p> <p>This requirement establishes a single risk-level, and the assigned VRF is consistent with that risk level.</p>		
Proposed VSL – PRC-005-6, R1			
Lower	Moderate	High	Severe
The entity’s PSMP failed to specify whether one Component Type is being addressed by time-based or performance-based maintenance, or a combination of both. (Part 1.1)	The entity’s PSMP failed to specify whether two Component Types are being addressed by time-based or performance-based maintenance, or a combination of both. (Part 1.1)	The entity’s PSMP failed to specify whether three Component Types are being addressed by time-based or performance-based maintenance, or a combination of both. (Part 1.1). OR	The entity failed to establish a PSMP. OR The entity’s PSMP failed to specify whether four or more Component Types are being addressed by time-based or performance-based maintenance, or a combination of both. (Part 1.1).

Proposed VSL – PRC-005-6, R1			
Lower	Moderate	High	Severe
		<p>The entity’s PSMP failed to include the applicable monitoring attributes applied to each Component Type consistent with the maintenance intervals specified in Tables 1-1 through 1-5, Table 2, Table 3, Table 4-1 through 4-3, and Table 5 where monitoring is used to extend the maintenance intervals beyond those specified for unmonitored Components. (Part 1.2).</p>	<p>OR</p> <p>The entity’s PSMP failed to include applicable station batteries in a time-based program (Part 1.1)</p>

VRF and VSL Justifications – PRC-005-6, R1	
NERC VSL Guidelines	Meets NERC’s VSL Guidelines—There is an incremental aspect to the violation and the VSLs follow the guidelines for incremental violations.
FERC VSL G1 VSL Assignments Should Not Have the Unintended Consequence of Lowering the Current Level of Compliance	This VSL is consistent with the current VSLs associated with the existing requirements of the standards being replaced by this proposed standard.
FERC VSL G2 VSL Level Assignments Should Ensure Uniformity and Consistency in the Determination of Penalties Guideline 2a: The Single VSL Assignment Category for "Binary" Requirements Is Not Consistent Guideline 2b: VSL Assignments that Contain Ambiguous Language	Guideline 2a: N/A Guideline 2b: The proposed VSL does not use any ambiguous terminology, thereby supporting uniformity and consistency in the determination of similar penalties for similar violations.

VRF and VSL Justifications – PRC-005-6, R1

FERC VSL G3 VSL Assignment Should Be Consistent with the Corresponding Requirement	The proposed VSL uses similar terminology to that used in the associated requirement, and is therefore consistent with the requirement.
FERC VSL G4 VSL Assignment Should Be Based on A Single Violation, Not on A Cumulative Number of Violations	The VSL is based on a single violation and not cumulative violations.

VRF and VSL Justifications – PRC-005-6, R2	
Proposed VRF	Medium
NERC VRF Discussion	Failure to properly establish a performance-based Protection System Maintenance Program (PSMP) for Protection Systems designed to provide protection for BES Element(s) could directly affect the electrical state or the capability of the bulk power system. However, violation of this requirement is unlikely to lead to bulk power system instability, separation, or cascading failures. The applicable entities are always responsible for maintaining the reliability of the bulk power system regardless of the situation. This VRF emphasizes the risk to system performance that results from mal-performing Protection System Components. Failure to properly establish a performance-based Protection System Maintenance Program (PSMP) for Protection Systems will not, by itself, lead to instability, separation, or cascading failures. Thus, the requirement meets NERC’s criteria for a Medium VRF.
FERC VRF G1 Discussion	Guideline 1- Consistency w/ Blackout Report: N/A
FERC VRF G2 Discussion	Guideline 2- Consistency within a Reliability Standard: The requirement has no subpart(s); therefore, only one VRF was assigned and no conflict(s) exist.
FERC VRF G3 Discussion	Guideline 3- Consistency among Reliability Standards: The SDT has determined that there is no consistency among existing approved Standards relative to requirements of this nature. The SDT has assigned a MEDIUM VRF, which is consistent with recent FERC guidance on FAC-008-3 Requirement R2 and FAC-013-2 Requirement R1, which are similar in nature to PRC-005-6 Requirement R1.
FERC VRF G4 Discussion	Guideline 4- Consistency with NERC Definitions of VRFs: Failure to properly establish a performance-based Protection System Maintenance Program (PSMP) for.

VRF and VSL Justifications – PRC-005-6, R2			
Proposed VRF	Medium		
	Protection Systems designed to provide protection for BES Element(s) could directly affect the electrical state or the capability of the bulk power system. However, violation of this requirement is unlikely to lead to bulk power system instability, separation, or cascading failures. The applicable entities are always responsible for maintaining the reliability of the bulk power system regardless of the situation. This VRF emphasizes the risk to system performance that results from mal-performing Protection System Components. Failure to properly establish a performance-based Protection System Maintenance Program (PSMP) for Protection Systems will not, by itself, lead to instability, separation, or cascading failures. Thus, the requirement meets NERC’s criteria for a Medium VRF.		
FERC VRF G5 Discussion	Guideline 5- Treatment of Requirements that Co-mingle More than One Obligation: This requirement establishes a single risk-level, and the assigned VRF is consistent with that risk level.		
Proposed VSL – PRC-005-6, R2			
Lower	Moderate	High	Severe
The entity uses performance-based maintenance intervals in its PSMP but failed to reduce Countable Events to no more than 4% within three years.	N/A	The entity uses performance-based maintenance intervals in its PSMP but failed to reduce Countable Events to no more than 4% within four years.	The entity uses performance-based maintenance intervals in its PSMP but: 1) Failed to establish the technical justification described within Requirement R2 for the initial use of the performance-based PSMP

Proposed VSL – PRC-005-6, R2			
Lower	Moderate	High	Severe
			<p>OR</p> <p>2) Failed to reduce countable events to no more than 4% within five years</p> <p>OR</p> <p>3) Maintained a Segment with less than 60 Components</p> <p>OR</p> <p>4) Failed to:</p> <ul style="list-style-type: none"> • Annually update the list of Components, <p>OR</p> <ul style="list-style-type: none"> • Annually perform maintenance on the greater of 5% of the Segment population or 3 Components, <p>OR</p> <ul style="list-style-type: none"> • Annually analyze the program activities and results for each Segment.

VRF and VSL Justifications – PRC-005-6, R2	
NERC VSL Guidelines	Meets NERC’s VSL Guidelines—There is an incremental aspect to the violation and the VSLs follow the guidelines for incremental violations.
FERC VSL G1 VSL Assignments Should Not Have the Unintended Consequence of Lowering the Current Level of Compliance	This VSL is consistent with the current VSLs associated with the existing requirements of the standards being replaced by this proposed standard.
FERC VSL G2 VSL Assignments Should Ensure Uniformity and Consistency in the Determination of Penalties Guideline 2a: The Single VSL Assignment Category for "Binary" Requirements Is Not Consistent	Guideline 2a: N/A Guideline 2b: The proposed VSL does not use any ambiguous terminology, thereby supporting uniformity and consistency in the determination of similar penalties for similar violations.

VRF and VSL Justifications – PRC-005-6, R2

Guideline 2b: VSL Assignments that Contain Ambiguous Language	
FERC VSL G3 VSL Assignment Should Be Consistent with the Corresponding Requirement	The proposed VSL uses similar terminology to that used in the associated requirement, and is therefore consistent with the requirement.
FERC VSL G4 VSL Assignment Should Be Based on A Single Violation, Not on A Cumulative Number of Violations	The VSL is based on a single violation and not cumulative violations.

VRF and VSL Justifications – PRC-005-6, R3	
Proposed VRF	High
NERC VRF Discussion	Failure to implement and follow its Protection System Maintenance Program (PSMP) could, under emergency, abnormal, or restorative conditions anticipated by the preparations, directly cause or contribute to bulk electric system instability, separation, or a cascading sequence of failures, or could place the bulk electric system at an unacceptable risk of instability, separation, or cascading failures, or could hinder restoration to a normal condition. Thus, this requirement meets the criteria for a High VRF.
FERC VRF G1 Discussion	Guideline 1- Consistency w/ Blackout Report: N/A
FERC VRF G2 Discussion	Guideline 2- Consistency within a Reliability Standard: The requirement has no subpart(s); therefore, only one VRF was assigned and no conflict(s) exist.
FERC VRF G3 Discussion	Guideline 3- Consistency among Reliability Standards: The only Reliability Standards with similar goals are those being replaced by this standard, and the High VRF assignment for this requirement is consistent with the assigned VRFs for companion requirements in those existing standards.
FERC VRF G4 Discussion	Guideline 4- Consistency with NERC Definitions of VRFs: Failure to implement and follow its Protection System Maintenance Program (PSMP) could, under emergency, abnormal, or restorative conditions anticipated by the preparations, directly cause or contribute to bulk electric system instability, separation, or a cascading sequence of failures, or could place the bulk electric system at an unacceptable risk of instability, separation, or cascading failures, or could hinder restoration to a normal condition. Thus, this requirement meets the criteria for a High VRF.
FERC VRF G5 Discussion	Guideline 5- Treatment of Requirements that Co-mingle More than One Obligation: This requirement establishes a single risk-level, and the assigned VRF is consistent with that risk level.

Proposed VSL – PRC-005-6, R3			
Lower	Moderate	High	Severe
For Components included within a time-based maintenance program, the entity failed to maintain 5% or less of the total Components included within a specific Component Type, in accordance with the minimum maintenance activities and maximum maintenance intervals prescribed within Tables 1-1 through 1-5, Table 2, Table 3, Table 4-1 through 4-3, and Table 5.	For Components included within a time-based maintenance program, the entity failed to maintain more than 5% but 10% or less of the total Components included within a specific Component Type, in accordance with the minimum maintenance activities and maximum maintenance intervals prescribed within Tables 1-1 through 1-5, Table 2, Table 3, Table 4-1 through 4-3, and Table 5.	For Components included within a time-based maintenance program, the entity failed to maintain more than 10% but 15% or less of the total Components included within a specific Component Type, in accordance with the minimum maintenance activities and maximum maintenance intervals prescribed within Tables 1-1 through 1-5, Table 2, Table 3, Table 4-1 through 4-3, and Table 5.	For Components included within a time-based maintenance program, the entity failed to maintain more than 15% of the total Components included within a specific Component Type, in accordance with the minimum maintenance activities and maximum maintenance intervals prescribed within Tables 1-1 through 1-5, Table 2, Table 3, Table 4-1 through 4-3, and Table 5.

VRF and VSL Justifications – PRC-005-6, R3	
NERC VSL Guidelines	Meets NERC’s VSL Guidelines—There is an incremental aspect to the violation and the VSLs follow the guidelines for incremental violations.
FERC VSL G1 VSL Assignments Should Not Have the Unintended Consequence of Lowering the Current Level of Compliance	This VSL is consistent with the current VSLs associated with the existing requirements of the standards being replaced by this proposed standard.
FERC VSL G2 VSL Assignments Should Ensure Uniformity and Consistency in the Determination of Penalties Guideline 2a: The Single VSL Assignment Category for "Binary" Requirements Is Not Consistent Guideline 2b: VSL Assignments that Contain Ambiguous Language	Guideline 2a: N/A Guideline 2b: The proposed VSL does not use any ambiguous terminology, thereby supporting uniformity and consistency in the determination of similar penalties for similar violations.

VRF and VSL Justifications – PRC-005-6, R3	
FERC VSL G3 VSL Assignment Should Be Consistent with the Corresponding Requirement	The proposed VSL uses similar terminology to that used in the associated requirement, and is therefore consistent with the requirement.
FERC VSL G4 VSL Assignment Should Be Based on A Single Violation, Not on A Cumulative Number of Violations	The VSL is based on a single violation and not cumulative violations.

VRF and VSL Justifications – PRC-005-6, R4	
Proposed VRF	High
NERC VRF Discussion	Failure to implement and follow its Protection System Maintenance Program (PSMP) could, under emergency, abnormal, or restorative conditions anticipated by the preparations, directly cause or contribute to bulk electric system instability, separation, or a cascading sequence of failures, or could place the bulk electric system at an unacceptable risk of instability, separation, or cascading failures, or could hinder restoration to a normal condition. Thus, this requirement meets the criteria for a High VRF.
FERC VRF G1 Discussion	Guideline 1- Consistency w/ Blackout Report: N/A
FERC VRF G2 Discussion	Guideline 2- Consistency within a Reliability Standard: The requirement has no subpart(s); therefore, only one VRF was assigned and no conflict(s) exist.
FERC VRF G3 Discussion	Guideline 3- Consistency among Reliability Standards: The only Reliability Standards with similar goals are those being replaced by this standard, and the High VRF assignment for this requirement is consistent with the assigned VRFs for companion requirements in those existing standards.
FERC VRF G4 Discussion	Guideline 4- Consistency with NERC Definitions of VRFs: Failure to implement and follow its Protection System Maintenance Program (PSMP) could, under emergency, abnormal, or restorative conditions anticipated by the preparations, directly cause or contribute to bulk electric system instability, separation, or a cascading sequence of failures, or could place the bulk electric system at an unacceptable risk of instability, separation, or cascading failures, or could hinder restoration to a normal condition. Thus, this requirement meets the criteria for a High VRF.
FERC VRF G5 Discussion	Guideline 5- Treatment of Requirements that Co-mingle More than One Obligation: This requirement establishes a single risk-level, and the assigned VRF is consistent with that risk level.

Proposed VSL – PRC-005-6, R4			
Lower	Moderate	High	Severe
For Components included within a performance-based maintenance program, the entity failed to maintain 5% or less of the annual scheduled maintenance for a specific Component Type in accordance with their performance-based PSMP.	For Components included within a performance-based maintenance program, the entity failed to maintain more than 5% but 10% or less of the annual scheduled maintenance for a specific Component Type in accordance with their performance-based PSMP.	For Components included within a performance-based maintenance program, the entity failed to maintain more than 10% but 15% or less of the annual scheduled maintenance for a specific Component Type in accordance with their performance-based PSMP.	For Components included within a performance-based maintenance program, the entity failed to maintain more than 15% of the annual scheduled maintenance for a specific Component Type in accordance with their performance-based PSMP.

VRF and VSL Justifications – PRC-005-6, R4	
NERC VSL Guidelines	Meets NERC’s VSL Guidelines—There is an incremental aspect to the violation and the VSLs follow the guidelines for incremental violations.
FERC VSL G1 VSL Assignments Should Not Have the Unintended Consequence of Lowering the Current Level of Compliance	This VSL is consistent with the current VSLs associated with the existing requirements of the standards being replaced by this proposed standard.
FERC VSL G2 VSL Assignments Should Ensure Uniformity and Consistency in the Determination of Penalties Guideline 2a: The Single VSL Assignment Category for "Binary" Requirements Is Not Consistent Guideline 2b: VSL Assignments that Contain Ambiguous Language	Guideline 2a: N/A Guideline 2b: The proposed VSL does not use any ambiguous terminology, thereby supporting uniformity and consistency in the determination of similar penalties for similar violations.

VRF and VSL Justifications – PRC-005-6, R4

FERC VSL G3 VSL Assignment Should Be Consistent with the Corresponding Requirement	The proposed VSL uses similar terminology to that used in the associated requirement, and is therefore consistent with the requirement.
FERC VSL G4 VSL Assignment Should Be Based on A Single Violation, Not on A Cumulative Number of Violations	The VSL is based on a single violation and not cumulative violations.

VRF and VSL Justifications – PRC-005-6, R5	
Proposed VRF	Medium
NERC VRF Discussion	Failure to initiate resolution of an unresolved maintenance issue for a Protection System Component could directly affect the electrical state or the capability of the bulk power system. However, violation of this requirement is unlikely to lead to bulk power system instability, separation, or cascading failures. The applicable entities are always responsible for maintaining the reliability of the bulk power system regardless of the situation. This VRF emphasizes the risk to system performance that results from mal-performing Protection System Components. Failure to initiate resolution of an unresolved maintenance issue for a Protection System Component will not, by itself, lead to instability, separation, or cascading failures. Thus, the requirement meets NERC’s criteria for a Medium VRF.
FERC VRF G1 Discussion	Guideline 1- Consistency w/ Blackout Report: N/A
FERC VRF G2 Discussion	Guideline 2- Consistency within a Reliability Standard: The requirement has no subpart(s); therefore, only one VRF was assigned and no conflict(s) exist.
FERC VRF G3 Discussion	Guideline 3- Consistency among Reliability Standards: The only requirement within approved Standards, PRC-004-2a Requirements R1 and R2 contain a similar requirement and is assigned a HIGH VRF. However, these requirements contain several subparts, and the VRF must address the most egregious risk related to these subparts, and a comparison to these requirements may be irrelevant. PRC-022-1 Requirement R1.5 contains only a similar requirement, and is assigned a MEDIUM VRF. FAC-003-2 Requirement R5 contains only a similar requirement, and is assigned a MEDIUM VRF.
FERC VRF G4 Discussion	Guideline 4- Consistency with NERC Definitions of VRFs: Failure to initiate resolution of an unresolved maintenance issue for a Protection System Component could directly affect the electrical state or the capability of the bulk power system.

VRF and VSL Justifications – PRC-005-6, R5			
Proposed VRF	Medium		
	<p>However, violation of this requirement is unlikely to lead to bulk power system instability, separation, or cascading failures. The applicable entities are always responsible for maintaining the reliability of the bulk power system regardless of the situation. This VRF emphasizes the risk to system performance that results from mal-performing Protection System Components. Failure to initiate resolution of an unresolved maintenance issue for a Protection System Component will not, by itself, lead to instability, separation, or cascading failures. Thus, the requirement meets NERC’s criteria for a Medium VRF.</p>		
FERC VRF G5 Discussion	<p>Guideline 5- Treatment of Requirements that Co-mingle More than One Obligation: This requirement establishes a single risk-level, and the assigned VRF is consistent with that risk level.</p>		
Proposed VSL – PRC-005-6, R5			
Lower	Moderate	High	Severe
The entity failed to undertake efforts to correct 5 or fewer identified Unresolved Maintenance Issues.	The entity failed to undertake efforts to correct greater than 5, but less than or equal to 10 identified Unresolved Maintenance Issues.	The entity failed to undertake efforts to correct greater than 10, but less than or equal to 15 identified Unresolved Maintenance Issues.	The entity failed to undertake efforts to correct greater than 15 identified Unresolved Maintenance Issues.

VRF and VSL Justifications – PRC-005-6, R5	
NERC VSL Guidelines	Meets NERC’s VSL Guidelines—There is an incremental aspect to the violation and the VSLs follow the guidelines for incremental violations.
FERC VSL G1 VSL Assignments Should Not Have the Unintended Consequence of Lowering the Current Level of Compliance	The Requirement in PRC-005-6 is identical to that in PRC-005-3, which has identical VSLs.
FERC VSL G2 VSL Assignments Should Ensure Uniformity and Consistency in the Determination of Penalties Guideline 2a: The Single VSL Assignment Category for "Binary" Requirements Is Not Consistent Guideline 2b: VSL Assignments that Contain Ambiguous Language	Guideline 2a: N/A Guideline 2b: The proposed VSL does not use any ambiguous terminology, thereby supporting uniformity and consistency in the determination of similar penalties for similar violations.

VRF and VSL Justifications – PRC-005-6, R5

FERC VSL G3 VSL Assignment Should Be Consistent with the Corresponding Requirement	The proposed VSL uses similar terminology to that used in the associated requirement, and is therefore consistent with the requirement.
FERC VSL G4 VSL Assignment Should Be Based on A Single Violation, Not on A Cumulative Number of Violations	The VSL is based on a single violation and not cumulative violations.

Violation Risk Factor and Violation Severity Level Justifications

Project 2007-17.4 PRC-005-6

Protection System, Automatic Reclosing and Sudden Pressure Relaying Maintenance

Violation Risk Factor and Violation Severity Level Justifications

This document provides the drafting team's justification for assignment of violation risk factors (VRFs) and violation severity levels (VSLs) for each requirement in PRC-005-62 - Protection System, Automatic Reclosing and Sudden Pressure Relaying Maintenance.

Each primary requirement is assigned a VRF and a set of one or more VSLs. These elements support the determination of an initial value range for the Base Penalty Amount regarding violations of requirements in FERC-approved Reliability Standards, as defined in the ERO Sanction Guidelines.

The Protection System Maintenance and Testing Standard Drafting Team applied the following NERC criteria and FERC Guidelines when proposing VRFs and VSLs for the requirements under this project:

NERC Criteria – VRFs

High Risk Requirement

A requirement that, if violated, could directly cause or contribute to bulk electric system instability, separation, or a cascading sequence of failures, or could place the bulk electric system at an unacceptable risk of instability, separation, or cascading failures; or, a requirement in a planning time frame that, if violated, could, under emergency, abnormal, or restorative conditions anticipated by the preparations, directly cause or contribute to bulk electric system instability, separation, or a cascading sequence of failures, or could place the bulk electric system at an unacceptable risk of instability, separation, or cascading failures, or could hinder restoration to a normal condition.

Medium Risk Requirement

A requirement that, if violated, could directly affect the electrical state or the capability of the bulk electric system, or the ability to effectively monitor and control the bulk electric system. However, violation of a medium risk requirement is unlikely to lead to bulk electric system instability, separation, or cascading failures; or, a requirement in a planning time frame that, if violated, could, under emergency, abnormal, or restorative conditions anticipated by the preparations, directly and adversely affect the electrical state or capability of the bulk electric system, or the ability to effectively monitor, control, or restore the bulk electric system. However, violation of a medium risk requirement is unlikely, under emergency, abnormal, or restoration conditions anticipated by the

preparations, to lead to bulk electric system instability, separation, or cascading failures, nor to hinder restoration to a normal condition.

Lower Risk Requirement

A requirement that is administrative in nature and a requirement that, if violated, would not be expected to adversely affect the electrical state or capability of the bulk electric system, or the ability to effectively monitor and control the bulk electric system; or, a requirement that is administrative in nature and a requirement in a planning time frame that, if violated, would not, under the emergency, abnormal, or restorative conditions anticipated by the preparations, be expected to adversely affect the electrical state or capability of the bulk electric system, or the ability to effectively monitor, control, or restore the bulk electric system. A planning requirement that is administrative in nature.

FERC VRF Guidelines

Guideline (1) — Consistency with the Conclusions of the Final Blackout Report

The Commission seeks to ensure that VRFs assigned to Requirements of Reliability Standards in these identified areas appropriately reflect their historical critical impact on the reliability of the Bulk-Power System.

In the VSL Order, FERC listed critical areas (from the Final Blackout Report) where violations could severely affect the reliability of the Bulk-Power System:

- Emergency operations
- Vegetation management
- Operator personnel training
- Protection systems and their coordination
- Operating tools and backup facilities
- Reactive power and voltage control
- System modeling and data exchange
- Communication protocol and facilities
- Requirements to determine equipment ratings
- Synchronized data recorders
- Clearer criteria for operationally critical facilities
- Appropriate use of transmission loading relief

Guideline (2) — Consistency within a Reliability Standard

The Commission expects a rational connection between the sub-Requirement VRF assignments and the main Requirement VRF assignment.

Guideline (3) — Consistency among Reliability Standards

The Commission expects the assignment of VRFs corresponding to Requirements that address similar reliability goals in different Reliability Standards would be treated comparably.

Guideline (4) — Consistency with NERC’s Definition of the VRF Level

Guideline (4) was developed to evaluate whether the assignment of a particular VRF level conforms to NERC’s definition of that risk level.

Guideline (5) — Treatment of Requirements that Co-mingle More Than One Obligation

Where a single Requirement co-mingles a higher risk reliability objective and a lesser risk reliability objective, the VRF assignment for such Requirements must not be watered down to reflect the lower risk level associated with the less important objective of the Reliability Standard.

The following discussion addresses how the SDT considered FERC’s VRF Guidelines 2 through 5. The team did not address Guideline 1 directly because of an apparent conflict between Guidelines 1 and 4. Whereas Guideline 1 identifies a list of topics that encompass nearly all topics within NERC’s Reliability Standards and implies that these requirements should be assigned a “High” VRF, Guideline 4 directs assignment of VRFs based on the impact of a specific requirement to the reliability of the system. The SDT believes that Guideline 4 is reflective of the intent of VRFs in the first instance and therefore concentrated its approach on the reliability impact of the requirements.

PRC-005-~~X-6~~ Protection System, Automatic Reclosing and Sudden Pressure Relaying Maintenance is a revision of PRC-005-3 Protection System and Automatic Reclosing Maintenance with the stated purpose: To document and implement programs for the maintenance of all Protection Systems, Automatic Reclosing, and Sudden Pressure Relaying affecting the reliability of the Bulk Electric System (BES) so that they are kept in working order.

PRC-005-~~X-6~~ has five (5) requirements that address the inclusion of Sudden Pressure Relaying. A Table of minimum maintenance activities and maximum maintenance intervals for Sudden Pressure Relaying has been added to PRC-005-3 to address FERC’s directives from Order 758. The revised standard requires that entities develop an appropriate Protection System Maintenance Program (PSMP), that they implement their PSMP, and that, in the event they are unable to restore Sudden Pressure Relaying Components to proper working order while performing maintenance, they initiate the follow-up activities necessary to resolve those maintenance issues.

The requirements of PRC-005-~~X-6~~ map one-to-one with the requirements of PRC-005-3. The drafting team did not revise the VRFs for the requirements of PRC-005-3.

PRC-005-~~X-6~~ Requirements R1 and R2 are related to developing and documenting a Protection System Maintenance Program. The Standard Drafting Team determined that the assignment of a VRF of Medium was consistent with the NERC criteria that violations of these requirements could directly affect the electrical state or the capability of the bulk electric system, or the ability to effectively monitor and control the bulk electric system but are unlikely to lead to bulk electric system instability, separation, or cascading failures. Additionally, a review of the body of existing NERC Standards with approved VRFs revealed that requirements with similar reliability objectives in other standards are largely assigned a VRF of Medium.

PRC-005-~~6~~⁴ Requirements R3 and R4 are related to implementation of the Protection System Maintenance Program. The SDT determined that the assignment of a VRF of High was consistent with the NERC criteria that that violation of these requirements could directly cause or contribute to bulk electric system instability, separation, or a cascading sequence of failures, or could place the bulk electric system at an unacceptable risk of instability, separation, or cascading failures. Additionally, a review of the body of existing NERC Standards with approved VRFs revealed that requirements with similar reliability objectives in other standards are assigned a VRF of High.

PRC-005-~~X-6~~ Requirement R5 relates to the initiation of resolution of unresolved maintenance issues, which describe situations where an entity was unable to restore a Component to proper working order during the performance of the maintenance activity. The Standard Drafting Team determined that the assignment of a VRF of Medium was consistent with the NERC criteria that violation of this requirements could directly affect the electrical state or the capability of the bulk electric system, or the ability to effectively monitor and control the bulk electric system but are unlikely to lead to bulk electric system instability, separation, or cascading failures. Additionally, a review of the body of existing NERC Standards with approved VRFs revealed that requirements with similar reliability objectives in other standards are largely assigned a VRF of Medium.

NERC Criteria - VSLs

VSLs define the degree to which compliance with a requirement was not achieved. Each requirement must have at least one VSL. While it is preferable to have four VSLs for each requirement, some requirements do not have multiple “degrees” of noncompliant performance and may have only one, two, or three VSLs.

VSLs should be based on the guidelines shown in the table below:

Lower	Moderate	High	Severe
<p>Missing a minor element (or a small percentage) of the required performance</p> <p>The performance or product measured has significant value as it almost meets the full intent of the requirement.</p>	<p>Missing at least one significant element (or a moderate percentage) of the required performance.</p> <p>The performance or product measured still has significant value in meeting the intent of the requirement.</p>	<p>Missing more than one significant element (or is missing a high percentage) of the required performance or is missing a single vital Component.</p> <p>The performance or product has limited value in meeting the intent of the requirement.</p>	<p>Missing most or all of the significant elements (or a significant percentage) of the required performance.</p> <p>The performance measured does not meet the intent of the requirement or the product delivered cannot be used in meeting the intent of the requirement.</p>

FERC Order on VSLs

In its June 19, 2008 Order on VSLs, FERC indicated it would use the following four guidelines for determining whether to approve VSLs:

Guideline 1: VSL Assignments Should Not Have the Unintended Consequence of Lowering the Current Level of Compliance

- Compare the VSLs to any prior Levels of Non-compliance and avoid significant changes that may encourage a lower level of compliance than was required when Levels of Non-compliance were used.

Guideline 2: VSL Assignments Should Ensure Uniformity and Consistency in the Determination of Penalties

- Guideline 2a: A violation of a “binary” type requirement must be a “Severe” VSL.
- Guideline 2b: Do not use ambiguous terms such as “minor” and “significant” to describe noncompliant performance.

Guideline 3: VSL Assignment Should Be Consistent with the Corresponding Requirement

- VSLs should not expand on what is required in the requirement.

Guideline 4: VSL Assignment Should Be Based on A Single Violation, Not on A Cumulative Number of Violations

- . . . unless otherwise stated in the requirement, each instance of non-compliance with a requirement is a separate violation. Section 4 of the Sanction Guidelines states that assessing penalties on a per violation per day basis is the “default” for penalty calculations.

VRF and VSL Justifications

VRF and VSL Justifications – PRC-005- 5 , R1	
Proposed VRF	Medium
NERC VRF Discussion	Failure to establish a Protection System Maintenance Program (PSMP) for Protection Systems designed to provide protection for BES Element(s) could directly affect the electrical state or the capability of the bulk power system. However, violation of this requirement is unlikely to lead to bulk power system instability, separation, or cascading failures. The applicable entities are always responsible for maintaining the reliability of the bulk power system regardless of the situation. This VRF emphasizes the risk to system performance that results from mal-performing Protection System Components. Failure to establish a Protection System Maintenance Program (PSMP) for Protection Systems will not, by itself, lead to instability, separation, or cascading failures. Thus, the requirement meets NERC’s criteria for a Medium VRF.
FERC VRF G1 Discussion	Guideline 1- Consistency w/ Blackout Report: N/A
FERC VRF G2 Discussion	Guideline 2- Consistency within a Reliability Standard: The requirement has no sub-requirements so only one VRF was assigned. The requirement utilizes Parts to identify the items to be included within a Protection System Maintenance Program. The VRF for this requirement is consistent with others in the standard with regard to relative risk; therefore, there is no conflict.
FERC VRF G3 Discussion	Guideline 3- Consistency among Reliability Standards: The SDT has determined that there is no consistency among existing approved Standards relative to requirements of this nature. The SDT has assigned a MEDIUM VRF, which is consistent with recent FERC guidance on FAC-008-3 Requirement R2 and FAC-013-2 Requirement R1, which are similar in nature to PRC-005- 5 Requirement R1.

VRF and VSL Justifications – PRC-005- X-5 , R1			
Proposed VRF	Medium		
FERC VRF G4 Discussion	<p>Guideline 4- Consistency with NERC Definitions of VRFs:</p> <p>Failure to establish a Protection System Maintenance Program (PSMP) for Protection Systems designed to provide protection for BES Element(s) could directly affect the electrical state or the capability of the bulk power system. However, violation of this requirement is unlikely to lead to bulk power system instability, separation, or cascading failures. The applicable entities are always responsible for maintaining the reliability of the bulk power system regardless of the situation. This VRF emphasizes the risk to system performance that results from mal-performing Protection System Components. Failure to establish a Protection System Maintenance Program (PSMP) for Protection Systems will not, by itself, lead to instability, separation, or cascading failures. Thus, the requirement meets NERC’s criteria for a Medium VRF.</p>		
FERC VRF G5 Discussion	<p>Guideline 5- Treatment of Requirements that Co-mingle More than One Obligation:</p> <p>This requirement establishes a single risk-level, and the assigned VRF is consistent with that risk level.</p>		
Proposed VSL – PRC-005- X-5 , R1			
Lower	Moderate	High	Severe
The entity’s PSMP failed to specify whether one Component Type is being addressed by time-based or performance-based maintenance, or a combination of both. (Part 1.1)	The entity’s PSMP failed to specify whether two Component Types are being addressed by time-based or performance-based maintenance, or a combination of both. (Part 1.1)	The entity’s PSMP failed to specify whether three Component Types are being addressed by time-based or performance-based maintenance, or a combination of both. (Part 1.1). OR	The entity failed to establish a PSMP. OR The entity’s PSMP failed to specify whether four or more Component Types are being addressed by time-based or performance-based maintenance, or a combination of both. (Part 1.1).

Proposed VSL – PRC-005- 4-5 , R1			
Lower	Moderate	High	Severe
		<p>The entity’s PSMP failed to include the applicable monitoring attributes applied to each Component Type consistent with the maintenance intervals specified in Tables 1-1 through 1-5, Table 2, Table 3, Table 4-1 through 4-23, and Table 5 where monitoring is used to extend the maintenance intervals beyond those specified for unmonitored Components. (Part 1.2).</p>	<p>OR</p> <p>The entity’s PSMP failed to include applicable station batteries in a time-based program (Part 1.1)</p>

VRF and VSL Justifications – PRC-005-~~4-6~~, R1

<p>NERC VSL Guidelines</p>	<p>Meets NERC’s VSL Guidelines—There is an incremental aspect to the violation and the VSLs follow the guidelines for incremental violations.</p>
<p>FERC VSL G1 VSL Assignments Should Not Have the Unintended Consequence of Lowering the Current Level of Compliance</p>	<p>This VSL is consistent with the current VSLs associated with the existing requirements of the standards being replaced by this proposed standard.</p>
<p>FERC VSL G2 VSL Level Assignments Should Ensure Uniformity and Consistency in the Determination of Penalties Guideline 2a: The Single VSL Assignment Category for "Binary" Requirements Is Not Consistent Guideline 2b: VSL Assignments that Contain Ambiguous Language</p>	<p>Guideline 2a: N/A</p> <p>Guideline 2b: The proposed VSL does not use any ambiguous terminology, thereby supporting uniformity and consistency in the determination of similar penalties for similar violations.</p>

VRF and VSL Justifications – PRC-005-~~4.6~~, R1

FERC VSL G3 VSL Assignment Should Be Consistent with the Corresponding Requirement	The proposed VSL uses similar terminology to that used in the associated requirement, and is therefore consistent with the requirement.
FERC VSL G4 VSL Assignment Should Be Based on A Single Violation, Not on A Cumulative Number of Violations	The VSL is based on a single violation and not cumulative violations.

VRF and VSL Justifications – PRC-005- X-5 , R2	
Proposed VRF	Medium
NERC VRF Discussion	Failure to properly establish a performance-based Protection System Maintenance Program (PSMP) for Protection Systems designed to provide protection for BES Element(s) could directly affect the electrical state or the capability of the bulk power system. However, violation of this requirement is unlikely to lead to bulk power system instability, separation, or cascading failures. The applicable entities are always responsible for maintaining the reliability of the bulk power system regardless of the situation. This VRF emphasizes the risk to system performance that results from mal-performing Protection System Components. Failure to properly establish a performance-based Protection System Maintenance Program (PSMP) for Protection Systems will not, by itself, lead to instability, separation, or cascading failures. Thus, the requirement meets NERC’s criteria for a Medium VRF.
FERC VRF G1 Discussion	Guideline 1- Consistency w/ Blackout Report: N/A
FERC VRF G2 Discussion	Guideline 2- Consistency within a Reliability Standard: The requirement has no subpart(s); therefore, only one VRF was assigned and no conflict(s) exist.
FERC VRF G3 Discussion	Guideline 3- Consistency among Reliability Standards: The SDT has determined that there is no consistency among existing approved Standards relative to requirements of this nature. The SDT has assigned a MEDIUM VRF, which is consistent with recent FERC guidance on FAC-008-3 Requirement R2 and FAC-013-2 Requirement R1, which are similar in nature to PRC-005- X-6 Requirement R1.
FERC VRF G4 Discussion	Guideline 4- Consistency with NERC Definitions of VRFs: Failure to properly establish a performance-based Protection System Maintenance Program (PSMP) for.

VRF and VSL Justifications – PRC-005- X-5 , R2			
Proposed VRF	Medium		
	Protection Systems designed to provide protection for BES Element(s) could directly affect the electrical state or the capability of the bulk power system. However, violation of this requirement is unlikely to lead to bulk power system instability, separation, or cascading failures. The applicable entities are always responsible for maintaining the reliability of the bulk power system regardless of the situation. This VRF emphasizes the risk to system performance that results from mal-performing Protection System Components. Failure to properly establish a performance-based Protection System Maintenance Program (PSMP) for Protection Systems will not, by itself, lead to instability, separation, or cascading failures. Thus, the requirement meets NERC’s criteria for a Medium VRF.		
FERC VRF G5 Discussion	Guideline 5- Treatment of Requirements that Co-mingle More than One Obligation: This requirement establishes a single risk-level, and the assigned VRF is consistent with that risk level.		
Proposed VSL – PRC-005- X-5 , R2			
Lower	Moderate	High	Severe
The entity uses performance-based maintenance intervals in its PSMP but failed to reduce Countable Events to no more than 4% within three years.	N/A	The entity uses performance-based maintenance intervals in its PSMP but failed to reduce Countable Events to no more than 4% within four years.	The entity uses performance-based maintenance intervals in its PSMP but: 1) Failed to establish the technical justification described within Requirement R2 for the initial use of the performance-based PSMP

Proposed VSL – PRC-005- 4.5 , R2			
Lower	Moderate	High	Severe
			<p>OR</p> <p>2) Failed to reduce countable events to no more than 4% within five years</p> <p>OR</p> <p>3) Maintained a Segment with less than 60 Components</p> <p>OR</p> <p>4) Failed to:</p> <ul style="list-style-type: none"> • Annually update the list of Components, <p>OR</p> <ul style="list-style-type: none"> • Annually perform maintenance on the greater of 5% of the Segment population or 3 Components, <p>OR</p> <ul style="list-style-type: none"> • Annually analyze the program activities and results for each Segment.

VRF and VSL Justifications – PRC-005-~~4-5~~, R2

<p>NERC VSL Guidelines</p>	<p>Meets NERC’s VSL Guidelines—There is an incremental aspect to the violation and the VSLs follow the guidelines for incremental violations.</p>
<p>FERC VSL G1 VSL Assignments Should Not Have the Unintended Consequence of Lowering the Current Level of Compliance</p>	<p>This VSL is consistent with the current VSLs associated with the existing requirements of the standards being replaced by this proposed standard.</p>
<p>FERC VSL G2 VSL Assignments Should Ensure Uniformity and Consistency in the Determination of Penalties Guideline 2a: The Single VSL Assignment Category for "Binary" Requirements Is Not Consistent</p>	<p>Guideline 2a: N/A</p> <p>Guideline 2b: The proposed VSL does not use any ambiguous terminology, thereby supporting uniformity and consistency in the determination of similar penalties for similar violations.</p>

VRF and VSL Justifications – PRC-005-~~4-5~~, R2

Guideline 2b: VSL Assignments that Contain Ambiguous Language	
FERC VSL G3 VSL Assignment Should Be Consistent with the Corresponding Requirement	The proposed VSL uses similar terminology to that used in the associated requirement, and is therefore consistent with the requirement.
FERC VSL G4 VSL Assignment Should Be Based on A Single Violation, Not on A Cumulative Number of Violations	The VSL is based on a single violation and not cumulative violations.

VRF and VSL Justifications – PRC-005- X-5 , R3	
Proposed VRF	High
NERC VRF Discussion	Failure to implement and follow its Protection System Maintenance Program (PSMP) could, under emergency, abnormal, or restorative conditions anticipated by the preparations, directly cause or contribute to bulk electric system instability, separation, or a cascading sequence of failures, or could place the bulk electric system at an unacceptable risk of instability, separation, or cascading failures, or could hinder restoration to a normal condition. Thus, this requirement meets the criteria for a High VRF.
FERC VRF G1 Discussion	Guideline 1- Consistency w/ Blackout Report: N/A
FERC VRF G2 Discussion	Guideline 2- Consistency within a Reliability Standard: The requirement has no subpart(s); therefore, only one VRF was assigned and no conflict(s) exist.
FERC VRF G3 Discussion	Guideline 3- Consistency among Reliability Standards: The only Reliability Standards with similar goals are those being replaced by this standard, and the High VRF assignment for this requirement is consistent with the assigned VRFs for companion requirements in those existing standards.
FERC VRF G4 Discussion	Guideline 4- Consistency with NERC Definitions of VRFs: Failure to implement and follow its Protection System Maintenance Program (PSMP) could, under emergency, abnormal, or restorative conditions anticipated by the preparations, directly cause or contribute to bulk electric system instability, separation, or a cascading sequence of failures, or could place the bulk electric system at an unacceptable risk of instability, separation, or cascading failures, or could hinder restoration to a normal condition. Thus, this requirement meets the criteria for a High VRF.
FERC VRF G5 Discussion	Guideline 5- Treatment of Requirements that Co-mingle More than One Obligation: This requirement establishes a single risk-level, and the assigned VRF is consistent with that risk level.

Proposed VSL – PRC-005- 4.5 , R3			
Lower	Moderate	High	Severe
For Components included within a time-based maintenance program, the entity failed to maintain 5% or less of the total Components included within a specific Component Type, in accordance with the minimum maintenance activities and maximum maintenance intervals prescribed within Tables 1-1 through 1-5, Table 2, Table 3, Table 4-1 through 4- 32 , and Table 5.	For Components included within a time-based maintenance program, the entity failed to maintain more than 5% but 10% or less of the total Components included within a specific Component Type, in accordance with the minimum maintenance activities and maximum maintenance intervals prescribed within Tables 1-1 through 1-5, Table 2, Table 3, Table 4-1 through 4- 32 , and Table 5.	For Components included within a time-based maintenance program, the entity failed to maintain more than 10% but 15% or less of the total Components included within a specific Component Type, in accordance with the minimum maintenance activities and maximum maintenance intervals prescribed within Tables 1-1 through 1-5, Table 2, Table 3, Table 4-1 through 4- 32 , and Table 5.	For Components included within a time-based maintenance program, the entity failed to maintain more than 15% of the total Components included within a specific Component Type, in accordance with the minimum maintenance activities and maximum maintenance intervals prescribed within Tables 1-1 through 1-5, Table 2, Table 3, Table 4-1 through 4- 32 , and Table 5.

VRF and VSL Justifications – PRC-005-~~6~~, R3

<p>NERC VSL Guidelines</p>	<p>Meets NERC’s VSL Guidelines—There is an incremental aspect to the violation and the VSLs follow the guidelines for incremental violations.</p>
<p>FERC VSL G1 VSL Assignments Should Not Have the Unintended Consequence of Lowering the Current Level of Compliance</p>	<p>This VSL is consistent with the current VSLs associated with the existing requirements of the standards being replaced by this proposed standard.</p>
<p>FERC VSL G2 VSL Assignments Should Ensure Uniformity and Consistency in the Determination of Penalties Guideline 2a: The Single VSL Assignment Category for "Binary" Requirements Is Not Consistent Guideline 2b: VSL Assignments that Contain Ambiguous Language</p>	<p>Guideline 2a: N/A</p> <p>Guideline 2b: The proposed VSL does not use any ambiguous terminology, thereby supporting uniformity and consistency in the determination of similar penalties for similar violations.</p>

VRF and VSL Justifications – PRC-005-~~4.5~~, R3

FERC VSL G3 VSL Assignment Should Be Consistent with the Corresponding Requirement	The proposed VSL uses similar terminology to that used in the associated requirement, and is therefore consistent with the requirement.
FERC VSL G4 VSL Assignment Should Be Based on A Single Violation, Not on A Cumulative Number of Violations	The VSL is based on a single violation and not cumulative violations.

VRF and VSL Justifications – PRC-005- 6 , R4	
Proposed VRF	High
NERC VRF Discussion	Failure to implement and follow its Protection System Maintenance Program (PSMP) could, under emergency, abnormal, or restorative conditions anticipated by the preparations, directly cause or contribute to bulk electric system instability, separation, or a cascading sequence of failures, or could place the bulk electric system at an unacceptable risk of instability, separation, or cascading failures, or could hinder restoration to a normal condition. Thus, this requirement meets the criteria for a High VRF.
FERC VRF G1 Discussion	Guideline 1- Consistency w/ Blackout Report: N/A
FERC VRF G2 Discussion	Guideline 2- Consistency within a Reliability Standard: The requirement has no subpart(s); therefore, only one VRF was assigned and no conflict(s) exist.
FERC VRF G3 Discussion	Guideline 3- Consistency among Reliability Standards: The only Reliability Standards with similar goals are those being replaced by this standard, and the High VRF assignment for this requirement is consistent with the assigned VRFs for companion requirements in those existing standards.
FERC VRF G4 Discussion	Guideline 4- Consistency with NERC Definitions of VRFs: Failure to implement and follow its Protection System Maintenance Program (PSMP) could, under emergency, abnormal, or restorative conditions anticipated by the preparations, directly cause or contribute to bulk electric system instability, separation, or a cascading sequence of failures, or could place the bulk electric system at an unacceptable risk of instability, separation, or cascading failures, or could hinder restoration to a normal condition. Thus, this requirement meets the criteria for a High VRF.
FERC VRF G5 Discussion	Guideline 5- Treatment of Requirements that Co-mingle More than One Obligation: This requirement establishes a single risk-level, and the assigned VRF is consistent with that risk level.

Proposed VSL – PRC-005- 6 , R4			
Lower	Moderate	High	Severe
For Components included within a performance-based maintenance program, the entity failed to maintain 5% or less of the annual scheduled maintenance for a specific Component Type in accordance with their performance-based PSMP.	For Components included within a performance-based maintenance program, the entity failed to maintain more than 5% but 10% or less of the annual scheduled maintenance for a specific Component Type in accordance with their performance-based PSMP.	For Components included within a performance-based maintenance program, the entity failed to maintain more than 10% but 15% or less of the annual scheduled maintenance for a specific Component Type in accordance with their performance-based PSMP.	For Components included within a performance-based maintenance program, the entity failed to maintain more than 15% of the annual scheduled maintenance for a specific Component Type in accordance with their performance-based PSMP.

VRF and VSL Justifications – PRC-005-~~4-5~~, R4

<p>NERC VSL Guidelines</p>	<p>Meets NERC’s VSL Guidelines—There is an incremental aspect to the violation and the VSLs follow the guidelines for incremental violations.</p>
<p>FERC VSL G1 VSL Assignments Should Not Have the Unintended Consequence of Lowering the Current Level of Compliance</p>	<p>This VSL is consistent with the current VSLs associated with the existing requirements of the standards being replaced by this proposed standard.</p>
<p>FERC VSL G2 VSL Assignments Should Ensure Uniformity and Consistency in the Determination of Penalties Guideline 2a: The Single VSL Assignment Category for "Binary" Requirements Is Not Consistent Guideline 2b: VSL Assignments that Contain Ambiguous Language</p>	<p>Guideline 2a: N/A</p> <p>Guideline 2b: The proposed VSL does not use any ambiguous terminology, thereby supporting uniformity and consistency in the determination of similar penalties for similar violations.</p>

VRF and VSL Justifications – PRC-005-~~4.5~~, R4

FERC VSL G3 VSL Assignment Should Be Consistent with the Corresponding Requirement	The proposed VSL uses similar terminology to that used in the associated requirement, and is therefore consistent with the requirement.
FERC VSL G4 VSL Assignment Should Be Based on A Single Violation, Not on A Cumulative Number of Violations	The VSL is based on a single violation and not cumulative violations.

VRF and VSL Justifications – PRC-005- X-5 , R5	
Proposed VRF	Medium
NERC VRF Discussion	Failure to initiate resolution of an unresolved maintenance issue for a Protection System Component could directly affect the electrical state or the capability of the bulk power system. However, violation of this requirement is unlikely to lead to bulk power system instability, separation, or cascading failures. The applicable entities are always responsible for maintaining the reliability of the bulk power system regardless of the situation. This VRF emphasizes the risk to system performance that results from mal-performing Protection System Components. Failure to initiate resolution of an unresolved maintenance issue for a Protection System Component will not, by itself, lead to instability, separation, or cascading failures. Thus, the requirement meets NERC’s criteria for a Medium VRF.
FERC VRF G1 Discussion	Guideline 1- Consistency w/ Blackout Report: N/A
FERC VRF G2 Discussion	Guideline 2- Consistency within a Reliability Standard: The requirement has no subpart(s); therefore, only one VRF was assigned and no conflict(s) exist.
FERC VRF G3 Discussion	Guideline 3- Consistency among Reliability Standards: The only requirement within approved Standards, PRC-004-2a Requirements R1 and R2 contain a similar requirement and is assigned a HIGH VRF. However, these requirements contain several subparts, and the VRF must address the most egregious risk related to these subparts, and a comparison to these requirements may be irrelevant. PRC-022-1 Requirement R1.5 contains only a similar requirement, and is assigned a MEDIUM VRF. FAC-003-2 Requirement R5 contains only a similar requirement, and is assigned a MEDIUM VRF.
FERC VRF G4 Discussion	Guideline 4- Consistency with NERC Definitions of VRFs: Failure to initiate resolution of an unresolved maintenance issue for a Protection System Component could directly affect the electrical state or the capability of the bulk power system.

VRF and VSL Justifications – PRC-005- X-5 , R5			
Proposed VRF	Medium		
	However, violation of this requirement is unlikely to lead to bulk power system instability, separation, or cascading failures. The applicable entities are always responsible for maintaining the reliability of the bulk power system regardless of the situation. This VRF emphasizes the risk to system performance that results from mal-performing Protection System Components. Failure to initiate resolution of an unresolved maintenance issue for a Protection System Component will not, by itself, lead to instability, separation, or cascading failures. Thus, the requirement meets NERC’s criteria for a Medium VRF.		
FERC VRF G5 Discussion	Guideline 5- Treatment of Requirements that Co-mingle More than One Obligation: This requirement establishes a single risk-level, and the assigned VRF is consistent with that risk level.		
Proposed VSL – PRC-005- X-6 , R5			
Lower	Moderate	High	Severe
The entity failed to undertake efforts to correct 5 or fewer identified Unresolved Maintenance Issues.	The entity failed to undertake efforts to correct greater than 5, but less than or equal to 10 identified Unresolved Maintenance Issues.	The entity failed to undertake efforts to correct greater than 10, but less than or equal to 15 identified Unresolved Maintenance Issues.	The entity failed to undertake efforts to correct greater than 15 identified Unresolved Maintenance Issues.

VRF and VSL Justifications – PRC-005- 6 , R5	
NERC VSL Guidelines	Meets NERC’s VSL Guidelines—There is an incremental aspect to the violation and the VSLs follow the guidelines for incremental violations.
FERC VSL G1 VSL Assignments Should Not Have the Unintended Consequence of Lowering the Current Level of Compliance	The Requirement in PRC-005- X-6 is identical to that in PRC-005-3, which has identical VSLs.
FERC VSL G2 VSL Assignments Should Ensure Uniformity and Consistency in the Determination of Penalties Guideline 2a: The Single VSL Assignment Category for "Binary" Requirements Is Not Consistent Guideline 2b: VSL Assignments that Contain Ambiguous Language	Guideline 2a: N/A Guideline 2b: The proposed VSL does not use any ambiguous terminology, thereby supporting uniformity and consistency in the determination of similar penalties for similar violations.

VRF and VSL Justifications – PRC-005-~~6~~, R5

FERC VSL G3 VSL Assignment Should Be Consistent with the Corresponding Requirement	The proposed VSL uses similar terminology to that used in the associated requirement, and is therefore consistent with the requirement.
FERC VSL G4 VSL Assignment Should Be Based on A Single Violation, Not on A Cumulative Number of Violations	The VSL is based on a single violation and not cumulative violations.

~~VRF and VSL Justifications – PRC-005-4, R6~~~~FERC VSL G3
VSL Assignment Should Be
Consistent with the
Corresponding Requirement~~~~The proposed VSL uses similar terminology to that used in the associated requirement, and is therefore consistent with the requirement.~~~~FERC VSL G4
VSL Assignment Should Be
Based on A Single Violation, Not
on A Cumulative Number of
Violations~~~~The VSL is based on a single violation and not cumulative violations.~~

NERC

NORTH AMERICAN ELECTRIC
RELIABILITY CORPORATION

Supplementary Reference and FAQ

PRC-005-4 Protection System Maintenance and
Testing

April 2015

RELIABILITY | ACCOUNTABILITY



3353 Peachtree Road NE
Suite 600, North Tower
Atlanta, GA 30326
404-446-2560 | www.nerc.com

Table of Contents

Table of Contents	ii
1. Introduction and Summary	1
2. Need for Verifying Protection System Performance	2
2.1 Existing NERC Standards for Protection System Maintenance and Testing.....	2
2.2 Protection System Definition.....	3
2.3 Applicability of New Protection System Maintenance Standards.....	3
2.3.1 Frequently Asked Questions:.....	4
2.4.1 Frequently Asked Questions:.....	6
3. Protection System and Automatic Reclosing Product Generations	15
4. Definitions.....	17
4.1 Frequently Asked Questions:.....	18
5. Time-Based Maintenance (TBM) Programs.....	20
5.1 Maintenance Practices	20
5.1.1 Frequently Asked Questions:	22
5.2 Extending Time-Based Maintenance	23
5.2.1 Frequently Asked Questions:	24
6. Condition-Based Maintenance (CBM) Programs.....	25
6.1 Frequently Asked Questions:.....	25
7. Time-Based Versus Condition-Based Maintenance.....	28
7.1 Frequently Asked Questions:.....	28
8. Maximum Allowable Verification Intervals	34
8.1 Maintenance Tests.....	34
8.1.1 Table of Maximum Allowable Verification Intervals.....	34

8.1.2 Additional Notes for Tables 1-1 through 1-5, Table 3, and Table 4.....	36
8.1.3 Frequently Asked Questions:	37
8.2 Retention of Records	42
8.2.1 Frequently Asked Questions:	43
8.3 Basis for Table 1 Intervals	45
8.4 Basis for Extended Maintenance Intervals for Microprocessor Relays	46
9. Performance-Based Maintenance Process.....	48
9.1 Minimum Sample Size.....	49
9.2 Frequently Asked Questions:.....	52
10. Overlapping the Verification of Sections of the Protection System.....	64
10.1 Frequently Asked Questions:.....	64
11. Monitoring by Analysis of Fault Records	65
11.1 Frequently Asked Questions:.....	66
12. Importance of Relay Settings in Maintenance Programs	67
12.1 Frequently Asked Questions:.....	67
13. Self-Monitoring Capabilities and Limitations	70
13.1 Frequently Asked Questions:.....	71
14. Notification of Protection System or Automatic Reclosing Failures	72
15. Maintenance Activities	73
15.1 Protective Relays (Table 1-1)	73
15.1.1 Frequently Asked Questions:	73
15.2 Voltage & Current Sensing Devices (Table 1-3)	73
15.2.1 Frequently Asked Questions:	75
15.3 Control circuitry associated with protective functions (Table 1-5)	76
15.3.1 Frequently Asked Questions:	77

15.4 Batteries and DC Supplies (Table 1-4).....	79
15.4.1 Frequently Asked Questions:	80
15.5 Associated communications equipment (Table 1-2).....	94
15.5.1 Frequently Asked Questions:	96
15.6 Alarms (Table 2).....	99
15.6.1 Frequently Asked Questions:	99
15.7 Distributed UFLS and Distributed UVLS Systems (Table 3).....	100
15.7.1 Frequently Asked Questions:	101
15.8 Automatic Reclosing (Table 4)	101
15.8.1 Frequently-asked Questions	101
15.9 Examples of Evidence of Compliance	103
15.9.1 Frequently Asked Questions:.....	105
References	106
Figures.....	108
Figure 1: Typical Transmission System	108
Figure 2: Typical Generation System	109
Figure 1 & 2 Legend – Components of Protection Systems	110
Appendix A.....	111
Appendix B	114
Protection System Maintenance Standard Drafting Team.....	114

1. Introduction and Summary

Note: This supplementary reference for PRC-005-4 is neither mandatory nor enforceable.

NERC currently has four Reliability Standards that are mandatory and enforceable in the United States and Canada and address various aspects of maintenance and testing of Protection and Control Systems.

These standards are:

PRC-005-1b — Transmission and Generation Protection System Maintenance and Testing

PRC-008-0 — Underfrequency Load Shedding Equipment Maintenance Programs

PRC-011-0 — UVLS System Maintenance and Testing

PRC-017-0 — Special Protection System Maintenance and Testing

While these standards require that applicable entities have a maintenance program for Protection Systems, and that these entities must be able to demonstrate they are carrying out such a program, there are no specifics regarding the technical requirements for Protection System maintenance programs. Furthermore, FERC Order 693 directed additional modifications respective to Protection System maintenance programs. PRC-005-3 will replace PRC-005-2 which combined and replaced PRC-005, PRC-008, PRC-011 and PRC-017. PRC-005-3 adds Automatic Reclosing to PRC-005-2. PRC-005-2 addressed these directed modifications and replaces PRC-005, PRC-008, PRC-011 and PRC-017.

FERC Order 758 further directed that maintenance of reclosing relays and sudden pressure relays that affect the reliable operation of the Bulk Power System be addressed. PRC-005-3 addresses this directive regarding reclosing relays, and, when approved, will supersede PRC-005-2. PRC-005-4 addresses this directive regarding sudden pressure relays and, when approved, will supersede PRC-005-3.

This document augments the Supplementary Reference and FAQ previously developed for PRC-005-2 by including discussion relevant to Automatic Reclosing added in PRC-005-3 and Sudden Pressure Relaying in PRC-005-4.

2. Need for Verifying Protection System Performance

Protective relays have been described as silent sentinels, and do not generally demonstrate their performance until a Fault or other power system problem requires that they operate to protect power system Elements, or even the entire Bulk Electric System (BES). Lacking Faults, switching operations or system problems, the Protection Systems may not operate, beyond static operation, for extended periods. A Misoperation - a false operation of a Protection System or a failure of the Protection System to operate, as designed, when needed - can result in equipment damage, personnel hazards, and wide-area Disturbances or unnecessary customer outages. Maintenance or testing programs are used to determine the performance and availability of Protection Systems.

Typically, utilities have tested Protection Systems at fixed time intervals, unless they had some incidental evidence that a particular Protection System was not behaving as expected. Testing practices vary widely across the industry. Testing has included system functionality, calibration of measuring devices, and correctness of settings. Typically, a Protection System must be visited at its installation site and, in many cases, removed from service for this testing.

Fundamentally, a Reliability Standard for Protection System Maintenance and Testing requires the performance of the maintenance activities that are necessary to detect and correct plausible age and service related degradation of the Protection System components, such that a properly built and commissioned Protection System will continue to function as designed over its service life.

Similarly station batteries, which are an important part of the station dc supply, are not called upon to provide instantaneous dc power to the Protection System until power is required by the Protection System to operate circuit breakers or interrupting devices to clear Faults or to isolate equipment.

2.1 Existing NERC Standards for Protection System Maintenance and Testing

For critical BES protection functions, NERC standards have required that each utility or asset owner define a testing program. The starting point is the existing Standard PRC-005, briefly restated as follows:

Purpose: To document and implement programs for the maintenance of all Protection Systems affecting the reliability of the Bulk Electric System (BES) so that these Protection Systems are kept in working order.

PRC-005-4 is not specific on where the boundaries of the Protection Systems lie. However, the definition of Protection System in the [NERC Glossary of Terms](#) used in Reliability Standards indicates what must be included as a minimum.

At the beginning of the project to develop PRC-005-2, the definition of Protection System was:

Protective relays, associated communications Systems, voltage and current sensing devices, station batteries and dc control circuitry.

Applicability: Owners of generation and transmission Protection Systems.

Requirements: The owner shall have a documented maintenance program with test intervals. The owner must keep records showing that the maintenance was performed at the specified intervals.

2.2 Protection System Definition

The most recently approved definition of Protection Systems is:

- Protective relays which respond to electrical quantities,
- Communications systems necessary for correct operation of protective functions,
- Voltage and current sensing devices providing inputs to protective relays,
- Station dc supply associated with protective functions (including station batteries, battery chargers, and non-battery-based dc supply), and
- Control circuitry associated with protective functions through the trip coil(s) of the circuit breakers or other interrupting devices.

2.3 Applicability of New Protection System Maintenance Standards

The BES purpose is to transfer bulk power. The applicability language has been changed from the original PRC-005:

“...affecting the reliability of the Bulk Electric System (BES)...”

To the present language:

“...that are installed for the purpose of detecting Faults on BES Elements (lines, buses, transformers, etc.).”

The drafting team intends that this standard will follow with any definition of the Bulk Electric System. There should be no ambiguity; if the Element is a BES Element, then the Protection System protecting that Element should then be included within this standard. If there is regional variation to the definition, then there will be a corresponding regional variation to the Protection Systems that fall under this standard.

There is no way for the Standard Drafting Team to know whether a specific 230KV line, 115KV line (even 69KV line), for example, should be included or excluded. Therefore, the team set the clear intent that the standard language should simply be applicable to Protection Systems for BES Elements.

The BES is a NERC defined term that, from time to time, may undergo revisions. Additionally, there may even be regional variations that are allowed in the present and future definitions. See the NERC Glossary of Terms for the present, in-force definition. See the applicable Regional Reliability Organization for any applicable allowed variations.

While this standard will undergo revisions in the future, this standard will not attempt to keep up with revisions to the NERC definition of BES, but, rather, simply make BES Protection Systems applicable.

The Standard is applied to Generator Owners (GO) and Transmission Owners (TO) because GOs and TOs have equipment that is BES equipment. The standard brings in Distribution Providers (DP) because, depending on the station configuration of a particular substation, there may be

Protection System equipment installed at a non-transmission voltage level (Distribution Provider equipment) that is wholly or partially installed to protect the BES. PRC-005-4 would apply to this equipment. An example is underfrequency load-shedding, which is frequently applied well down into the distribution system to meet PRC-007-0.

PRC-005-2 replaced the existing PRC-005, PRC-008, PRC-011 and PRC-017. Much of the original intent of those standards was carried forward whenever it was possible to continue the intent without a disagreement with FERC Order 693. For example, the original PRC-008 was constructed quite differently than the original PRC-005. The drafting team agrees with the intent of this and notes that distributed tripping schemes would have to exhibit multiple failures to trip before they would prove to be significant, as opposed to a single failure to trip of, for example, a transmission Protection System Bus Differential lock-out relay. While many failures of these distribution breakers could add up to be significant, it is also believed that distribution breakers are operated often on just Fault clearing duty; and, therefore, the distribution circuit breakers are operated at least as frequently as stipulated in any requirement in this standard.

Additionally, since PRC-005-2 replaced PRC-011, it will be important to make the distinction between under-voltage Protection Systems that protect individual Loads and Protection Systems that are UVLS schemes that protect the BES. Any UVLS scheme that had been applicable under PRC-011 is now applicable under PRC-005-2. An example of an under-voltage load-shedding scheme that is not applicable to this standard is one in which the tripping action was intended to prevent low distribution voltage to a specific Load from a Transmission system that was intact except for the line that was out of service, as opposed to preventing a Cascading outage or Transmission system collapse.

It had been correctly noted that the devices needed for PRC-011 are the very same types of devices needed in PRC-005.

Thus, a standard written for Protection Systems of the BES can easily make the needed requirements for Protection Systems, and replace some other standards at the same time.

2.3.1 Frequently Asked Questions:

What exactly is the BES, or Bulk Electric System?

BES is the abbreviation for Bulk Electric System. BES is a term in the Glossary of Terms used in Reliability Standards, and is not being modified within this draft standard.

Why is Distribution Provider included within the Applicable Entities and as a responsible entity within several of the requirements? Wouldn't anyone having relevant Facilities be a Transmission Owner?

Depending on the station configuration of a particular substation, there may be Protection System equipment installed at a non-transmission voltage level (Distribution Provider equipment) that is wholly or partially installed to protect the BES. PRC-005-4 applies to this equipment. An example is underfrequency load-shedding, which is frequently applied well down into the distribution system to meet PRC-007-0.

We have an under voltage load-shedding (UVLS) system in place that prevents one of our distribution substations from supplying extremely low voltage in the case of a specific transmission line outage. The transmission line is part of the BES. Does this mean that our UVLS system falls within this standard?

The situation, as stated, indicates that the tripping action was intended to prevent low distribution voltage to a specific Load from a Transmission System that was intact, except for the line that was out of service, as opposed to preventing Cascading outage or Transmission System Collapse.

This standard is not applicable to this UVLS.

We have a UFLS or UVLS scheme that sheds the necessary Load through distribution-side circuit breakers and circuit reclosers. Do the trip-test requirements for circuit breakers apply to our situation?

No. Distributed tripping schemes would have to exhibit multiple failures to trip before they would prove to be significant, as opposed to a single failure to trip of, for example, a transmission Protection System bus differential lock-out relay. While many failures of these distribution breakers could add up to be significant, it is also believed that distribution breakers are operated often on just Fault clearing duty; and, therefore, the distribution circuit breakers are operated at least as frequently as any requirements that might have appeared in this standard.

We have a UFLS scheme that, in some locales, sheds the necessary Load through non-BES circuit breakers and, occasionally, even circuit switchers. Do the trip-test requirements for circuit breakers apply to our situation?

If your “non-BES circuit breaker” has been brought into this standard by the inclusion of UFLS requirements, and otherwise would not have been brought into this standard, then the answer is that there are no trip-test requirements. For these devices that are otherwise non-BES assets, these tripping schemes would have to exhibit multiple failures to trip before they would prove to be as significant as, for example, a single failure to trip of a transmission Protection System bus differential lock-out relay.

How does the “Facilities” section of “Applicability” track with the standards that will be retired once PRC-005-2 becomes effective?

In establishing PRC-005-2, the drafting team combined legacy standards PRC-005-1b, PRC-008-0, PRC-011-0, and PRC-017-0. The merger of the subject matter of these standards is reflected in Applicability 4.2.

The intent of the drafting team is that the legacy standards be reflected in PRC-005-2 as follows:

- Applicability of PRC-005-1b for Protection Systems relating to non-generator elements of the BES is addressed in 4.2.1;
- Applicability of PRC-008-0 for underfrequency load shedding systems is addressed in 4.2.2;
- Applicability of PRC-011-0 for undervoltage load shedding relays is addressed in 4.2.3;
- Applicability of PRC-017-0 for Remedial Action Schemes is addressed in 4.2.4;
- Applicability of PRC-005-1b for Protection Systems for BES generators is addressed in 4.2.5 and 4.2.6.

2.4 Applicable Relays

The NERC Glossary definition has a Protection System including relays, dc supply, current and voltage sensing devices, dc control circuitry and associated communications circuits. The relays to which this standard applies are those protective relays that respond to electrical quantities and provide a trip output to trip coils, dc control circuitry or associated communications equipment. This definition extends to IEEE Device No. 86 (lockout relay) and IEEE Device No. 94 (tripping or trip-free relay), as these devices are tripping relays that respond to the trip signal of the protective relay that processed the signals from the current and voltage-sensing devices.

Relays that respond to non-electrical inputs or impulses (such as, but not limited to, vibration, seismic, thermal or gas accumulation) are not included.

Automatic Reclosing is addressed in PRC-005-3 by explicitly addressing them outside the definition of Protection System. The specific locations for applicable Automatic Reclosing are addressed in Applicability Section 4.2.7.

Sudden Pressure Relaying is addressed in PRC-005-4 by explicitly addressing them outside the definition of Protection System. The specific locations for applicable Sudden Pressure Relaying are addressed in Applicability Section 4.2.1, 4.2.5.2, 4.2.5.3, and 4.2.6.

2.4.1 Frequently Asked Questions:

Are power circuit reclosers, reclosing relays, closing circuits and auto-restoration schemes covered in this Standard?

Yes. Automatic Reclosing includes reclosing relays and the associated dc control circuitry. Section 4.2.7 of the Applicability specifically limits the applicable reclosing relays to:

4.2.7 Automatic Reclosing

4.2.7.1 Automatic Reclosing applied on the terminals of Elements connected to the BES bus located at generating plant substations where the total installed gross generating plant capacity is greater than the gross capacity of the largest BES generating unit within the Balancing Authority Area or, if a member of a Reserve Sharing Group, the largest generating unit within the Reserve Sharing Group.

4.2.7.2 Automatic Reclosing applied on the terminals of all BES Elements at substations one bus away from generating plants specified in Section 4.2.7.1 when the substation is less than 10 circuit-miles from the generating plant substation.

4.2.7.3 Automatic Reclosing applied as an integral part of an RAS specified in Section 4.2.4.

Further, Footnote 1 to Applicability Section 4.2.7 establishes that Automatic Reclosing addressed in 4.2.7.1 and 4.2.7.2 may be excluded if the equipment owner can demonstrate that a close-in three-phase fault present for twice the normal clearing time (capturing a minimum trip-close-trip time delay) does not result in a total loss of gross generation in the Interconnection exceeding the gross capacity of the largest relevant BES generating unit where the Automatic Reclosing is applied.

Additionally, Footnote 2 to Applicability Section 4.2.7.1 advises that the entity's PSMP needs to remain current regarding the applicability of Automatic Reclosing Components relative to the largest generating unit within the Balancing Authority Area or Reserve Sharing Group.

The Applicability as detailed above was recommended by the NERC System Analysis and Modeling Subcommittee (SAMS) after a lengthy review of the use of reclosing within the BES. SAMS concluded that automatic reclosing is largely implemented throughout the BES as an operating convenience, and that automatic reclosing mal-performance affects BES reliability only when the reclosing is part of a Remedial Action Schemes, or when premature autoreclosing has the potential to cause generating unit or plant instability. A technical report, "Considerations for Maintenance and Testing of Autoreclosing Schemes — November 2012", is referenced in PRC-005-3 and provides a more detailed discussion of these concerns.

Why did the standard drafting team not include IEEE device numbers to describe Automatic Reclosing Relays?

The drafting team elected not to include IEEE device numbers to describe Automatic Reclosing because Automatic Reclosing component type could be a stand-alone electromechanical relay; or could be the 79 function within a microprocessor based multi-function relay(11).

What is synchronizing or synchronism check relay (Sync-Check - 25)?

A synchronizing device that produces an output that supervises closure of a circuit breaker between two circuits whose voltages are within prescribed limits of magnitude and phase angle. It may or may not include voltage or speed control. A sync-check relay permits the paralleling of two circuits that are within prescribed (usually wider) limits of voltage magnitude and phase angle.

How do I interpret Applicability Section 4.2.7 to determine applicability in the following examples:

At my generating plant substation, I have a total of 800 MW connected to one voltage level and 200 MW connected to another voltage level. How do I determine my gross capacity? Where do I consider Automatic Reclosing to be applicable?

Scenario number 1:

The 800 MW of generation is connected to a BES voltage level bus, the 200 MW

is connected to a non-BES voltage level bus, and there is no connection between the two buses locally or within 10 circuit miles from the generating plant substation. The largest single unit in the BA area is 750 MW.

In this case, the total installed gross generating capacity would be 800 MW. The two units are essentially independent plants.

The BES voltage level bus is considered to be the bus to which the 800 MW of generation is connected. Any BES Automatic Reclosing at this location, as well as other locations within 10 circuit miles, is considered to be applicable because 800 MW exceeds the largest single unit in the BA area.

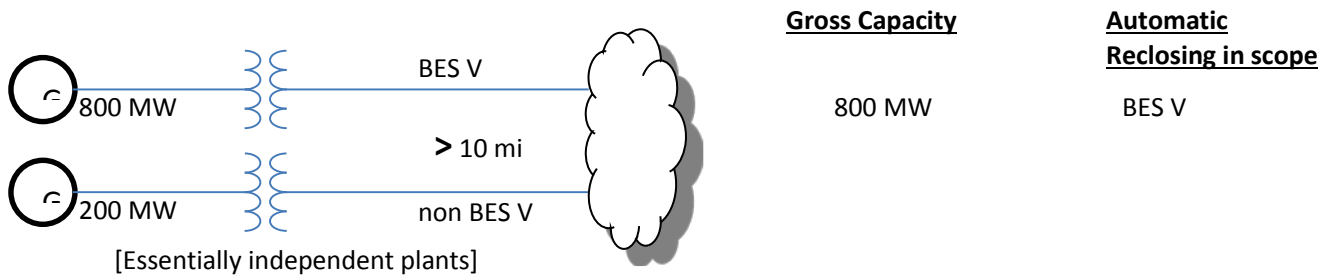

Scenario number 2:

The 800 MW of generation is connected to a BES voltage level bus, the 200 MW unit is connected to a non-BES voltage level bus, and there is a connection between the two buses locally or within 10 circuit miles from the generating plant substation. The largest single unit in the BA area is 750 MW.

In this case, reclosing into a fault on the BES system could impact the stability of the non-BES-connected generating units. Therefore, the total installed gross generating capacity would be 1000 MW.

The BES voltage level bus is considered to be the bus to which the 800 MW of generation is connected. Any BES Automatic Reclosing at this location, as well as other locations within 10 circuit miles, is considered to be applicable because total of 1000 MW exceeds the largest single unit in the BA area. However, the Automatic Reclosing on the non-BES voltage level bus is not applicable.

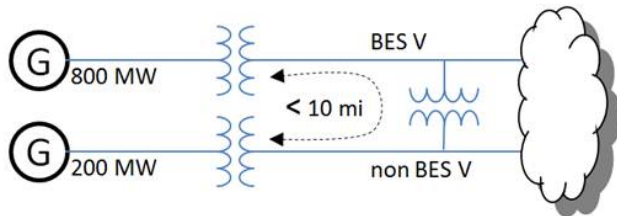

Gross Capacity

1000 MW

Automatic Reclosing in scope

BES V

Scenario number 3:

The 800 MW of generation is connected to a BES voltage level bus, the 200 MW unit is connected to a non-BES voltage level bus, and there is no connection between the two buses locally or within 10 circuit miles from the generating plant substation but the generating units connected at the BES voltage level do not operate independently of the units connected at the non BES voltage level (e.g., a combined cycle facility where 800 MW of combustion turbines are connected at a BES voltage level whose exhaust is used to power a 200 MW steam unit connected to a non BES voltage level. The largest single unit in the BA area is 750 MW.

In this case, the total installed gross generating capacity would be 1000 MW. Therefore, reclosing into a fault on the BES voltage level would result in a loss of the 800 MW combustion turbines and subsequently result in the loss of the 200 MW steam unit because of the loss of the heat source to its boiler.

The BES voltage level bus is considered to be the bus to which the 800 MW of generation is connected. Any BES Automatic Reclosing at this location, as well as other locations within 10 circuit miles, is considered to be applicable because total of 1000 MW exceeds the largest single unit in the BA area. However, the Automatic Reclosing on the non-BES voltage level bus is not applicable.

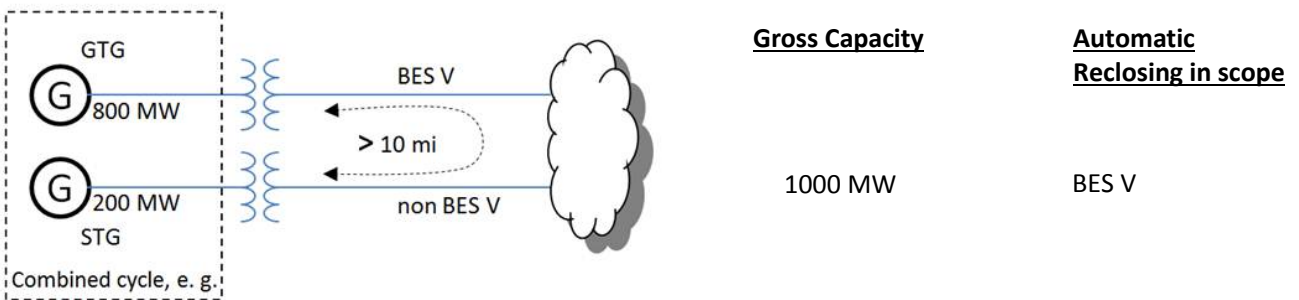

Scenario 4

The 800 MW of generation is connected at 345 kV and the 200 MW is connected at 138 kV with an autotransformer at the generating plant substation connecting the two voltage levels. The largest single unit in the BA area is 900 MW.

In this case, the total installed gross generating capacity would be 1000 MW and section 4.2.7.1 would be applicable to both the 345 kV Automatic Reclosing Components and the 138 kV Automatic Reclosing Components, since the total capacity of 1000 MW is larger than the largest single unit in the BA area.

However, if the 345 kV and the 138 kV systems can be shown to be uncoupled such that the 138 kV reclosing relays will not affect the stability of the 345 kV generating units then the 138 kV Automatic Reclosing Components need not be included per section 4.2.7.1.

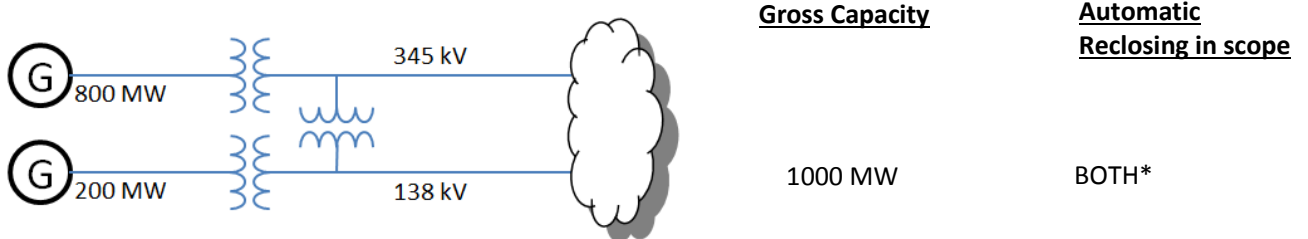

* The study detailed in Footnote 1 of the draft standard may eliminate the 138 kV Automatic Reclosing Components and/or the 345 kV Automatic Reclosing Components

Why does 4.2.7.2 specify “10 circuit miles”?

As noted in “Considerations for Maintenance and Testing of Autoreclosing Schemes — November 2012”, transmission line impedance on the order of one mile away typically provides adequate impedance to prevent generating unit instability and a 10 mile threshold provides sufficient margin.

Should I use MVA or MW when determining the installed gross generating plant capacity?

Be consistent with the rating used by the Balancing Authority for the largest BES generating unit within their area.

What value should we use for generating plant capacity in 4.2.7.1?

Use the value reported to the Balance Authority for generating plant capacity for planning and modeling purposes. This can be nameplate or other values based on generating plant limitations such as boiler or turbine ratings.

What is considered to be “one bus away” from the generation?

The BES voltage level bus is considered to be the generating plant substation bus to which the generator step-up transformer is connected. “One bus away” is the next bus, connected by either a transmission line or transformer.

I use my protective relays only as sources of metered quantities and breaker status for SCADA and EMS through a substation distributed RTU or data concentrator to the control center. What are the maintenance requirements for the relays?

This standard addresses Protection Systems that are installed for the purpose of detecting Faults on BES Elements (lines, buses, transformers, etc.). Protective relays, providing only the functions mentioned in the question, are not included.

Are Reverse Power Relays installed on the low-voltage side of distribution banks considered to be components of “Protection Systems that are installed for the purpose of detecting Faults on BES Elements (lines, buses, transformers, etc.)”?

Reverse power relays are often installed to detect situations where the transmission source becomes de-energized and the distribution bank remains energized from a source on the low-voltage side of the transformer and the settings are calculated based on the charging current of the transformer from the low-voltage side. Although these relays may operate as a result of a fault on a BES element, they are not ‘installed for the purpose of detecting’ these faults.

Why is the maintenance of Sudden Pressure Relaying being addressed in PRC-005-4?

Proper performance of Sudden Pressure Relaying supports the reliability of the BES because fault pressure relays can detect rapid changes in gas pressure, oil pressure, or oil flow that are indicative of faults within liquid-filled, wire-wound equipment such as turn-to-turn faults which may be undetected by Protection Systems. Additionally, Sudden Pressure

Relaying can quickly detect faults and operate to limit damage to liquid-filled, wire-wound equipment.

What type of devices are classified as fault pressure relay?

There are three main types of fault pressure relays; rapid gas pressure rise, rapid oil pressure rise, and rapid oil flow devices.

Rapid gas pressure devices monitor the pressure in the space above the oil (or other liquid), and initiate tripping action for a rapid rise in gas pressure resulting from the rapid expansion of the liquid caused by a fault. The sensor is located in the gas space.

Rapid oil pressure devices monitor the pressure in the oil (or other liquid), and initiate tripping action for a rapid pressure rise caused by a fault. The sensor is located in the liquid.

Rapid oil flow devices (“Buchholz”) monitor the liquid flow between a transformer/reactor and its conservator. Normal liquid flow occurs continuously with ambient temperature changes and with internal heating from loading and does not operate the rapid oil flow device. However, when an internal arc happens a sudden expansion of liquid can be monitored as rapid liquid flow from the transformer into the conservator resulting in actuation of the rapid oil flow device.

Are sudden pressure relays that only initiate an alarm included in the scope of PRC-005-4?

No, the definition of Sudden Pressure Relaying specifies only those that trip an interrupting device(s) to isolate the equipment it is monitoring.

Are pressure relief devices included in the scope of PRC-005-4?

No. PRDs are not included in the Sudden Pressure Relaying definition.

Is Sudden Pressure Relaying installed on distribution transformers included in PRC-005-4?

No, Applicability 4.2.1, 4.2.5, and 4.2.6, explicitly describes what Sudden Pressure Relaying is included within the standard.

Are non-electrical sensing devices (other than fault pressure relays) such as low oil level or high winding temperatures included in PRC-005-4?

No, based on the SPCS technical document, “Sudden Pressure Relays and Other Devices that Respond to Non-Electrical Quantities – December 2013,” the only applicable non-electrical sensing devices are Sudden Pressure Relays.

The standard specifically mentions auxiliary and lock-out relays. What is an auxiliary tripping relay?

An auxiliary relay, IEEE Device No. 94, is described in IEEE Standard C37.2-2008 as: “A device that functions to trip a circuit breaker, contactor, or equipment; to permit immediate tripping by other devices; or to prevent immediate reclosing of a circuit interrupter if it should open automatically, even though its closing circuit is maintained closed.”

What is a lock-out relay?

A lock-out relay, IEEE Device No. 86, is described in IEEE Standard C37.2 as: “A device that trips and maintains the associated equipment or devices inoperative until it is reset by an operator, either locally or remotely.”

3. Protection System and Automatic Reclosing Product Generations

The likelihood of failure and the ability to observe the operational state of a critical Protection System and Automatic Reclosing both depend on the technological generation of the relays, as well as how long they have been in service. Unlike many other transmission asset groups, protection and control systems have seen dramatic technological changes spanning several generations. During the past 20 years, major functional advances are primarily due to the introduction of microprocessor technology for power system devices, such as primary measuring relays, monitoring devices, control Systems, and telecommunications equipment.

Modern microprocessor-based relays have six significant traits that impact a maintenance strategy:

- Self-monitoring capability - the processors can check themselves, peripheral circuits, and some connected substation inputs and outputs, such as trip coil continuity. Most relay users are aware that these relays have self-monitoring, but are not focusing on exactly what internal functions are actually being monitored. As explained further below, every element critical to the Protection System must be monitored, or else verified periodically.
- Ability to capture Fault records showing how the Protection System responded to a Fault in its zone of protection, or to a nearby Fault for which it is required not to operate.
- Ability to meter currents and voltages, as well as status of connected circuit breakers, continuously during non-Fault times. The relays can compute values, such as MW and MVAR line flows, that are sometimes used for operational purposes, such as SCADA.
- Data communications via ports that provide remote access to all of the results of Protection System monitoring, recording and measurement.
- Ability to trip or close circuit breakers and switches through the Protection System outputs, on command from remote data communications messages, or from relay front panel button requests.
- Construction from electronic components, some of which have shorter technical life or service life than electromechanical components of prior Protection System generations.

There have been significant advances in the technology behind the other components of Protection Systems. Microprocessors are now a part of battery chargers, associated communications equipment, voltage and current-measuring devices, and even the control circuitry (in the form of software-latches replacing lock-out relays, etc.).

Any Protection System component can have self-monitoring and alarming capability, not just relays. Because of this technology, extended time intervals can find their way into all components of the Protection System.

This standard also recognizes the distinct advantage of using advanced technology to justifiably defer or even eliminate traditional maintenance. Just as a hand-held calculator does not require routine testing and calibration, neither does a calculation buried in a microprocessor-based device that results in a “lock-out.” Thus, the software-latch 86 that replaces an electro-mechanical 86 does not require routine trip testing. Any trip circuitry associated with the “soft 86” would still need applicable verification activities performed, but the actual “86” does not have to be “electrically operated” or even toggled.

4. Definitions

Protection System Maintenance Program (PSMP) — An ongoing program by which Protection System, Automatic Reclosing and Sudden Pressure Relaying Components are kept in working order and proper operation of malfunctioning Components is restored. A maintenance program for a specific Component includes one or more of the following activities:

- Verify — Determine that the Component is functioning correctly.
- Monitor — Observe the routine in-service operation of the Component.
- Test — Apply signals to a Component to observe functional performance or output behavior, or to diagnose problems.
- Inspect — Examine for signs of Component failure, reduced performance and degradation.
- Calibrate — Adjust the operating threshold or measurement accuracy of a measuring element to meet the intended performance requirement.

Automatic Reclosing — Includes the following Components:

- Reclosing relay
- Supervisory relay(s) — relay(s) that perform voltage and/or sync check functions that enables or disables operation of the reclosing relay
- Voltage sensing devices associated with the supervisory relay(s)
- Control circuitry associated with the reclosing relay or supervisory relay(s)

Sudden Pressure Relaying — A system that trips an interrupting device(s) to isolate the equipment it is monitoring and includes the following Components:

- Fault pressure relay — a mechanical relay or device that detects rapid changes in gas pressure, oil pressure, or oil flow that are indicative of faults within liquid-filled, wire-wound equipment
- Control circuitry associated with a fault pressure relay

Unresolved Maintenance Issue — A deficiency identified during a maintenance activity that causes the component to not meet the intended performance, cannot be corrected during the maintenance interval, and requires follow-up corrective action.

Segment — Components of a consistent design standard, or a particular model or type from a single manufacturer that typically share other common elements. Consistent performance is expected across the entire population of a Segment. A Segment must contain at least sixty (60) individual Components.

Component Type —

- Any one of the five specific elements of a Protection System.
- Any one of the four specific elements of Automatic Reclosing.
- Any one of the two specific elements of Sudden Pressure Relaying.

Component – Any individual discrete piece of equipment included in a Protection System, Automatic Reclosing, or Sudden Pressure Relaying.

Countable Event – A failure of a Component requiring repair or replacement, any condition discovered during the maintenance activities in Tables 1-1 through 1-5, Table 3, Tables 4-1 through 4-3, and Table 5, which requires corrective action or a Protection System Misoperation attributed to hardware failure or calibration failure. Misoperations due to product design errors, software errors, relay settings different from specified settings, Protection System Component, Automatic Reclosing or Sudden Pressure Relaying configuration or application errors are not included in Countable Events.

4.1 Frequently Asked Questions:

Why does PRC-005-4 not specifically require maintenance and testing procedures, as reflected in the previous standard, PRC-005-1?

PRC-005-1 does not require detailed maintenance and testing procedures, but instead requires summaries of such procedures, and is not clear on what is actually required. PRC-005-4 requires a documented maintenance program, and is focused on establishing requirements rather than prescribing methodology to meet those requirements. Between the activities identified in the Tables 1-1 through 1-5, Table 2, Table 3, and Table 4 (collectively the “Tables”), and the various components of the definition established for a “Protection System Maintenance Program,” PRC-005-4 establishes the activities and time basis for a Protection System Maintenance Program to a level of detail not previously required.

Please clarify what is meant by “restore” in the definition of maintenance.

The description of “restore” in the definition of a Protection System Maintenance Program addresses corrective activities necessary to assure that the component is returned to working order following the discovery of its failure or malfunction. The Maintenance Activities specified in the Tables do not present any requirements related to Restoration; R5 of the standard does require that the entity “shall demonstrate efforts to correct any identified Unresolved Maintenance Issues.” Some examples of restoration (or correction of Unresolved Maintenance Issues) include, but are not limited to, replacement of capacitors in distance relays to bring them to working order; replacement of relays, or other Protection System components, to bring the Protection System to working order; upgrade of electromechanical or solid-state protective relays to microprocessor-based relays following the discovery of failed components. Restoration, as used in this context, is not to be confused with restoration rules as used in system operations. Maintenance activity necessarily includes both the detection of problems and the repairs needed to eliminate those problems. This standard does not identify all of the Protection System problems that must be detected and eliminated, rather it is the intent of this standard that an entity determines the necessary working order for their various devices, and keeps them in working order. If an equipment item is repaired or replaced, then the entity can restart the maintenance-time-interval-clock, if desired; however, the replacement of equipment does not remove any documentation requirements that would have been required to verify compliance with time-interval requirements. In other words, do not discard maintenance data that goes to verify your work.

The retention of documentation for new and/or replaced equipment is all about proving that the maintenance intervals had been in compliance. For example, a long-range plan of upgrades

might lead an entity to ignore required maintenance; retaining the evidence of prior maintenance that existed before any retirements and upgrades proves compliance with the standard.

Please clarify what is meant by “...demonstrate efforts to correct an Unresolved Maintenance Issue...”; why not measure the completion of the corrective action?

Management of completion of the identified Unresolved Maintenance Issue is a complex topic that falls outside of the scope of this standard. There can be any number of supply, process and management problems that make setting repair deadlines impossible. The SDT specifically chose the phrase “demonstrate efforts to correct” (with guidance from NERC Staff) because of the concern that many more complex Unresolved Maintenance Issues might require greater than the remaining maintenance interval to resolve (and yet still be a “closed-end process”). For example, a problem might be identified on a VRLA battery during a six-month check. In instances such as one that requiring battery replacement as part of the long-term resolution, it is highly unlikely that the battery could be replaced in time to meet the six-calendar-month requirement for this maintenance activity. The SDT does not believe entities should be found in violation of a maintenance program requirement because of the inability to complete a remediation program within the original maintenance interval. The SDT does believe corrective actions should be timely, but concludes it would be impossible to postulate all possible remediation projects; and, therefore, impossible to specify bounding time frames for resolution of all possible Unresolved Maintenance Issues, or what documentation might be sufficient to provide proof that effective corrective action is being undertaken.

5. Time-Based Maintenance (TBM) Programs

Time-based maintenance is the process in which Protection System, Automatic Reclosing and Sudden Pressure Relaying Components are maintained or verified according to a time schedule. The scheduled program often calls for technicians to travel to the physical site and perform a functional test on Protection System components. However, some components of a TBM program may be conducted from a remote location - for example, tripping a circuit breaker by communicating a trip command to a microprocessor relay to determine if the entire Protection System tripping chain is able to operate the breaker. Similarly, all Protection System, and Sudden Pressure Relaying Components can have the ability to remotely conduct tests, either on-command or routinely; the running of these tests can extend the time interval between hands-on maintenance activities.

5.1 Maintenance Practices

Maintenance and testing programs often incorporate the following types of maintenance practices:

- TBM – time-based maintenance – externally prescribed maximum maintenance or testing intervals are applied for components or groups of components. The intervals may have been developed from prior experience or manufacturers’ recommendations. The TBM verification interval is based on a variety of factors, including experience of the particular asset owner, collective experiences of several asset owners who are members of a country or regional council, etc. The maintenance intervals are fixed and may range in number of months or in years.

TBM can include review of recent power system events near the particular terminal. Operating records may verify that some portion of the Protection System has operated correctly since the last test occurred. If specific protection scheme components have demonstrated correct performance within specifications, the maintenance test time clock can be reset for those components.

- PBM – Performance-Based Maintenance - intervals are established based on analytical or historical results of TBM failure rates on a statistically significant population of similar components. Some level of TBM is generally followed. Statistical analyses accompanied by adjustments to maintenance intervals are used to justify continued use of PBM-developed extended intervals when test failures or in-service failures occur infrequently.
- CBM – condition-based maintenance – continuously or frequently reported results from non-disruptive self-monitoring of components demonstrate operational status as those components remain in service. Whatever is verified by CBM does not require manual testing, but taking advantage of this requires precise technical focus on exactly what parts are included as part of the self-diagnostics. While the term “Condition-Based-Maintenance” (CBM) is no longer used within the standard itself, it is important to note that the concepts of CBM are a part of the standard (in the form of extended time intervals through status-monitoring). These extended time intervals are only allowed (in the absence of PBM) if the condition of the device is monitored (CBM). As a consequence of the “monitored-basis-time-intervals” existing within the standard, the explanatory

discussions within this Supplementary Reference concerned with CBM will remain in this reference and are discussed as CBM.

Microprocessor-based Protection System or Automatic Reclosing Components that perform continuous self-monitoring verify correct operation of most components within the device. Self-monitoring capabilities may include battery continuity, float voltages, unintentional grounds, the ac signal inputs to a relay, analog measuring circuits, processors and memory for measurement, protection, and data communications, trip circuit monitoring, and protection or data communications signals (and many, many more measurements). For those conditions, failure of a self-monitoring routine generates an alarm and may inhibit operation to avoid false trips. When internal components, such as critical output relay contacts, are not equipped with self-monitoring, they can be manually tested. The method of testing may be local or remote, or through inherent performance of the scheme during a system event.

The TBM is the overarching maintenance process of which the other types are subsets. Unlike TBM, PBM intervals are adjusted based on good or bad experiences. The CBM verification intervals can be hours, or even milliseconds between non-disruptive self-monitoring checks within or around components as they remain in service.

TBM, PBM, and CBM can be combined for individual components, or within a complete Protection System. The following diagram illustrates the relationship between various types of maintenance practices described in this section. In the Venn diagram, the overlapping regions show the relationship of TBM with PBM historical information and the inherent continuous monitoring offered through CBM.

This figure shows:

- Region 1: The TBM intervals that are increased based on known reported operational condition of individual components that are monitoring themselves.
- Region 2: The TBM intervals that are adjusted up or down based on results of analysis of maintenance history of statistically significant population of similar products that have been subject to TBM.
- Region 3: Optimal TBM intervals based on regions 1 and 2.

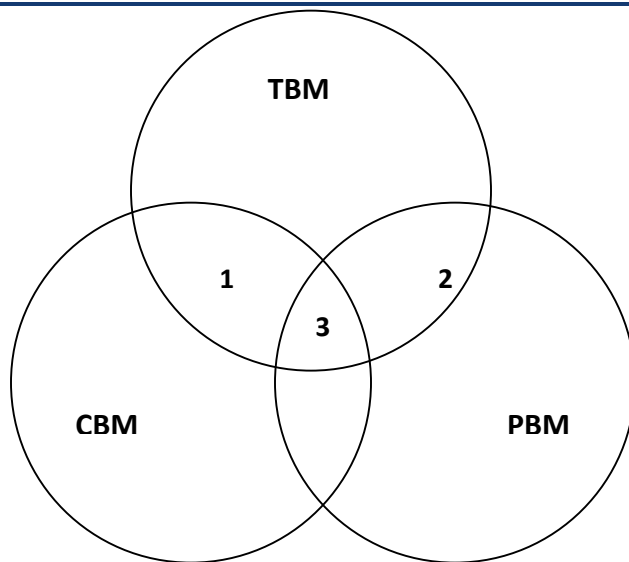

Relationship of time-based maintenance types

5.1.1 Frequently Asked Questions:

The standard seems very complicated, and is difficult to understand. Can it be simplified?

Because the standard is establishing parameters for condition-based Maintenance (R1) and Performance-Based Maintenance (R2), in addition to simple time-based Maintenance, it does appear to be complicated. At its simplest, an entity needs to **ONLY** perform time-based maintenance according to the unmonitored rows of the Tables. If an entity then wishes to take advantage of monitoring on its Protection System components and its available lengthened time intervals, then it may, as long as the component has the listed monitoring attributes. If an entity wishes to use historical performance of its Protection System components to perform Performance-Based Maintenance, then R2 applies.

Please see the following diagram, which provides a “flow chart” of the standard.

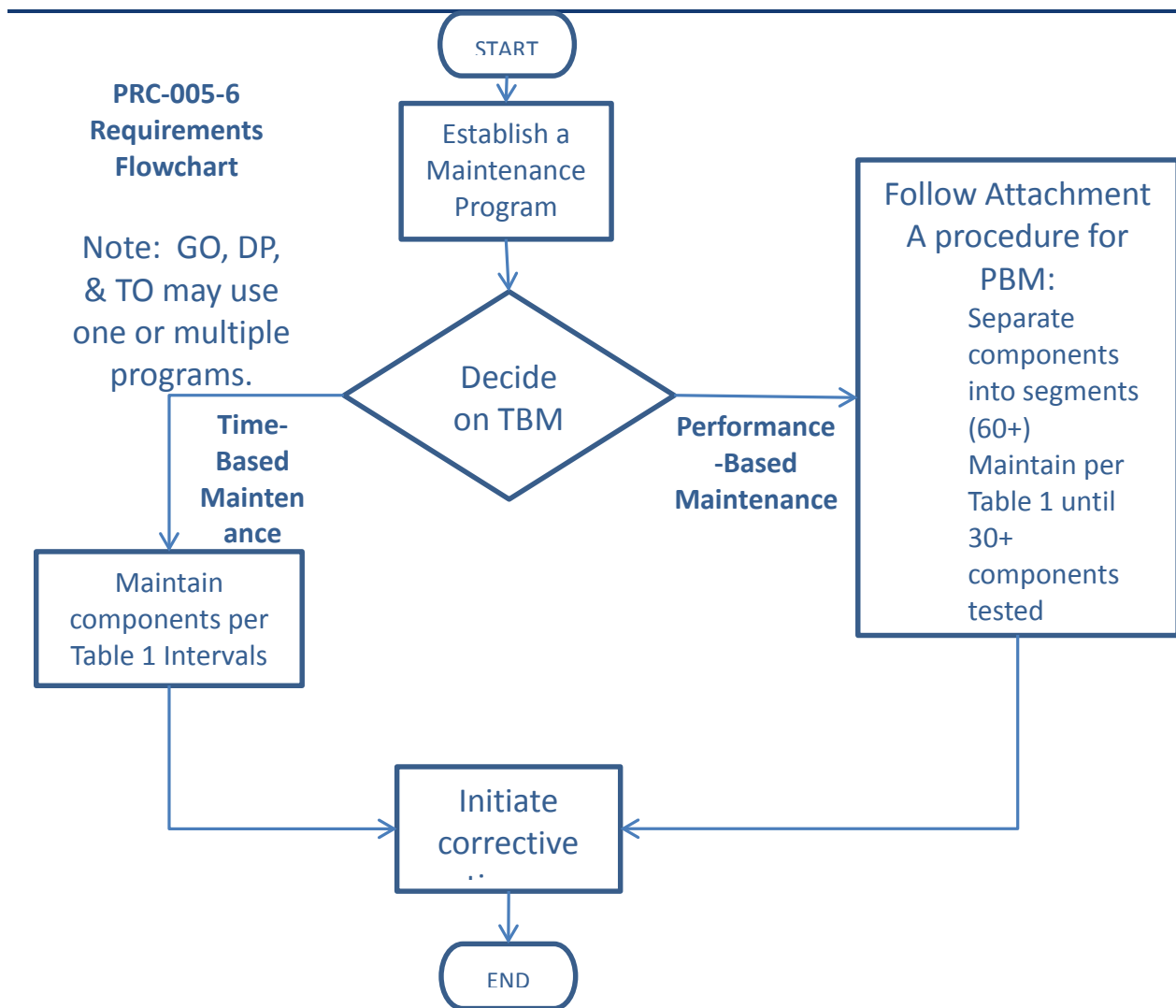

We have an electromechanical (unmonitored) relay that has a trip output to a lockout relay (unmonitored) which trips our transformer off-line by tripping the transformer's high-side and low-side circuit breakers. What testing must be done for this system?

This system is made up of components that are all unmonitored. Assuming a time-based Protection System Maintenance Program schedule (as opposed to a Performance-Based maintenance program), each component must be maintained per the most frequent hands-on activities listed in the Tables.

5.2 Extending Time-Based Maintenance

All maintenance is fundamentally time-based. Default time-based intervals are commonly established to assure proper functioning of each component of the Protection System, when data on the reliability of the components is not available other than observations from time-based maintenance. The following factors may influence the established default intervals:

- If continuous indication of the functional condition of a component is available (from relays or chargers or any self-monitoring device), then the intervals may be extended, or manual testing may be eliminated. This is referred to as condition-based maintenance or

CBM. CBM is valid only for precisely the components subject to monitoring. In the case of microprocessor-based relays, self-monitoring may not include automated diagnostics of every component within a microprocessor.

- Previous maintenance history for a group of components of a common type may indicate that the maintenance intervals can be extended, while still achieving the desired level of performance. This is referred to as Performance-Based Maintenance, or PBM. It is also sometimes referred to as reliability-centered maintenance, or RCM; but PBM is used in this document.
- Observed proper operation of a component may be regarded as a maintenance verification of the respective component or element in a microprocessor-based device. For such an observation, the maintenance interval may be reset only to the degree that can be verified by data available on the operation. For example, the trip of an electromechanical relay for a Fault verifies the trip contact and trip path, but only through the relays in series that actually operated; one operation of this relay cannot verify correct calibration.

Excessive maintenance can actually decrease the reliability of the component or system. It is not unusual to cause failure of a component by removing it from service and restoring it. The improper application of test signals may cause failure of a component. For example, in electromechanical overcurrent relays, test currents have been known to destroy convolution springs.

In addition, maintenance usually takes the component out of service, during which time it is not able to perform its function. Cutout switch failures, or failure to restore switch position, commonly lead to protection failures.

5.2.1 Frequently Asked Questions:

If I show the protective device out of service while it is being repaired, then can I add it back as a new protective device when it returns? If not, my relay testing history would show that I was out of compliance for the last maintenance cycle.

The maintenance and testing requirements (R5) (in essence) state “...shall demonstrate efforts to correct identified Unresolved Maintenance Issues.” The type of corrective activity is not stated; however it could include repairs or replacements.

Your documentation requirements will increase, of course, to demonstrate that your device tested bad and had corrective actions initiated. Your regional entity could very well ask for documentation showing status of your corrective actions.

6. Condition-Based Maintenance (CBM) Programs

Condition-based maintenance is the process of gathering and monitoring the information available from modern microprocessor-based relays and other intelligent electronic devices (IEDs) that monitor Protection System or Automatic Reclosing elements. These devices generate monitoring information during normal operation, and the information can be assessed at a convenient location remote from the substation. The information from these relays and IEDs is divided into two basic types:

1. Information can come from background self-monitoring processes, programmed by the manufacturer, or by the user in device logic settings. The results are presented by alarm contacts or points, front panel indications, and by data communications messages.
2. Information can come from event logs, captured files, and/or oscillographic records for Faults and Disturbances, metered values, and binary input status reports. Some of these are available on the device front panel display, but may be available via data communications ports. Large files of Fault information can only be retrieved via data communications. These results comprise a mass of data that must be further analyzed for evidence of the operational condition of the Protection System.

Using these two types of information, the user can develop an effective maintenance program carried out mostly from a central location remote from the substation. This approach offers the following advantages:

Non-invasive Maintenance: The system is kept in its normal operating state, without human intervention for checking. This reduces risk of damage, or risk of leaving the system in an inoperable state after a manual test. Experience has shown that keeping human hands away from equipment known to be working correctly enhances reliability.

Virtually Continuous Monitoring: CBM will report many hardware failure problems for repair within seconds or minutes of when they happen. This reduces the percentage of problems that are discovered through incorrect relaying performance. By contrast, a hardware failure discovered by TBM may have been there for much of the time interval between tests, and there is a good chance that some devices will show health problems by incorrect operation before being caught in the next test round. The frequent or continuous nature of CBM makes the effective verification interval far shorter than any required TBM maximum interval. To use the extended time intervals available through Condition Based Maintenance, simply look for the rows in the Tables that refer to monitored items.

6.1 Frequently Asked Questions:

My microprocessor relays and dc circuit alarms are contained on relay panels in a 24-hour attended control room. Does this qualify as an extended time interval condition-based (monitored) system?

Yes, provided the station attendant (plant operator, etc.) monitors the alarms and other indications (comparable to the monitoring attributes) and reports them within the given time limits that are stated in the criteria of the Tables.

When documenting the basis for inclusion of components into the appropriate levels of monitoring, as per Requirement R1 (Part 1.2) of the standard, is it necessary to provide this documentation about the device by listing of every component and the specific monitoring attributes of each device?

No. While maintaining this documentation on the device level would certainly be permissible, it is not necessary. Global statements can be made to document appropriate levels of monitoring for the entire population of a component type or portion thereof.

For example, it would be permissible to document the conclusion that all BES substation dc supply battery chargers are monitored by stating the following within the program description:

“All substation dc supply battery chargers are considered monitored and subject to the rows for monitored equipment of Table 1-4 requirements, as all substation dc supply battery chargers are equipped with dc voltage alarms and ground detection alarms that are sent to the manned control center.”

Similarly, it would be acceptable to use a combination of a global statement and a device-level list of exclusions. Example:

“Except as noted below, all substation dc supply battery chargers are considered monitored and subject to the rows for monitored equipment of Table 1-4 requirements, as all substation dc supply battery chargers are equipped with dc voltage alarms and ground detection alarms that are sent to the manned control center. The dc supply battery chargers of Substation X, Substation Y, and Substation Z are considered unmonitored and subject to the rows for unmonitored equipment in Table 1-4 requirements, as they are not equipped with ground detection capability.”

Regardless whether this documentation is provided by device listing of monitoring attributes, by global statements of the monitoring attributes of an entire population of component types, or by some combination of these methods, it should be noted that auditors may request supporting drawings or other documentation necessary to validate the inclusion of the device(s) within the appropriate level of monitoring. This supporting background information need not be maintained within the program document structure, but should be retrievable if requested by an auditor.

The applicability of R1.2 depends on the BES definition for Protection System to identify what components are to be covered by the Standard. One type of component is described as “Protective relays which respond to electrical quantities”. Would a protection function that is embedded in a Generator’s voltage regulator meet the BES definition for Protection System and thus be included in R1.2?

Yes. The fact that these functions are implemented by an excitation system or voltage regulator rather than a classical looking relay is immaterial. The devices monitor electrical parameters such as voltage and/or current and cause a trip of the generator in response to these signals. By implementing these functions in the excitation system, the excitation system has in essence become an elaborate form of a microprocessor relay.

The voltage regulator processes electrical quantities and has an output that trips the generator breaker, quite often through a lockout. Examples include voltage regulator electronic cards that monitor voltage for high V/Hz, high exciter field voltage or both. In oldergeneration regulators (1980s and 1990s) the protection functions are essentially electronic relays (not

electromechanical or microprocessor based but using transistors and potentiometers). Should either excess voltage condition be true, a contact mounted on the voltage regulator electronics board closes which, in turn, goes to an auxiliary relay or activates a lockout relay directly. The electronic quantities monitored include exciter field voltage, generator current, and generator terminal voltage.

7. Time-Based Versus Condition-Based Maintenance

Time-based and condition-based (or monitored) maintenance programs are both acceptable, if implemented according to technically sound requirements. Practical programs can employ a combination of time-based and condition-based maintenance. The standard requirements introduce the concept of optionally using condition monitoring as a documented element of a maintenance program.

The Federal Energy Regulatory Commission (FERC), in its Order Number 693 Final Rule, dated March 16, 2007 (18 CFR Part 40, Docket No. RM06-16-000) on Mandatory Reliability Standards for the Bulk-Power System, directed NERC to submit a modification to PRC-005-1b that includes a requirement that maintenance and testing of a Protection System must be carried out within a maximum allowable interval that is appropriate to the type of the Protection System and its impact on the reliability of the Bulk Power System. Accordingly, this Supplementary Reference Paper refers to the specific maximum allowable intervals in PRC-005-4. The defined time limits allow for longer time intervals if the maintained component is monitored.

A key feature of condition-based monitoring is that it effectively reduces the time delay between the moment of a protection failure and time the Protection System or Automatic Reclosing owner knows about it, for the monitored segments of the Protection System. In some cases, the verification is practically continuous - the time interval between verifications is minutes or seconds. Thus, technically sound, condition-based verification, meets the verification requirements of the FERC order even more effectively than the strictly time-based tests of the same system components.

The result is that:

This NERC standard permits utilities to use a technically sound approach and to take advantage of remote monitoring, data analysis, and control capabilities of modern Protection System and Automatic Reclosing Components to reduce the need for periodic site visits and invasive testing of components by on-site technicians. This periodic testing must be conducted within the maximum time intervals specified in the Tables of PRC-005-4.

7.1 Frequently Asked Questions:

What is a Calendar Year?

Calendar Year - January 1 through December 31 of any year. As an example, if an event occurred on June 17, 2009 and is on a "One Calendar Year Interval," the next event would have to occur on or before December 31, 2010.

Please provide an example of "4 Calendar Months".

If a maintenance activity is described as being needed every four Calendar Months then it is performed in a (given) month and due again four months later. For example a battery bank is inspected in month number 1 then it is due again before the end of the month number5. And specifically consider that you perform your battery inspection on January 3, 2010 then it must be inspected again before the end of May. Another example could be that a four-month inspection was performed in January is due in May, but if performed in March (instead of May) would still

be due four months later therefore the activity is due again July. Basically every “four Calendar Months” means to add four months from the last time the activity was performed.

Please provide an example of the unmonitored versus other levels of monitoring available?

An unmonitored Protection System has no monitoring and alarm circuits on the Protection System components. A Protection System component that has monitoring attributes but no alarm output connected is considered to be unmonitored.

A monitored Protection System or an individual monitored component of a Protection System has monitoring and alarm circuits on the Protection System components. The alarm circuits must alert, within 24 hours, a location wherein corrective action can be initiated. This location might be, but is not limited to, an Operations Center, Dispatch Office, Maintenance Center or even a portable SCADA system.

There can be a combination of monitored and unmonitored Protection Systems within any given scheme, substation or plant; there can also be a combination of monitored and unmonitored components within any given Protection System.

Example #1: A combination of monitored and unmonitored components within a given Protection System might be:

- A microprocessor relay with an internal alarm connected to SCADA to alert 24-hr staffed operations center; it has internal self-diagnosis and alarming. (monitored)
- Instrumentation transformers, with no monitoring, connected as inputs to that relay. (unmonitored)
- A vented Lead-Acid battery with a low voltage alarm for the station dc supply voltage and an unintentional grounds detection alarm connected to SCADA. (monitoring varies)
- A circuit breaker with a trip coil, and the trip circuit is not monitored. (unmonitored)

Given the particular components and conditions, and using Table 1 and Table 2, the particular components have maximum activity intervals of:

Every four calendar months, inspect:

- Electrolyte level (station dc supply voltage and unintentional ground detection is being maintained more frequently by the monitoring system).

Every 18 calendar months, verify/inspect the following:

- Battery bank ohmic values to station battery baseline (if performance tests are not opted)
- Battery charger float voltage
- Battery rack integrity
- Cell condition of all individual battery cells (where visible)
- Battery continuity
- Battery terminal connection resistance

-
- Battery cell-to-cell resistance (where available to measure)

Every six calendar years, perform/verify the following:

- Battery performance test (if internal ohmic tests or other measurements indicative of battery performance are not opted)
- Verify that each trip coil is able to operate the circuit breaker, interrupting device, or mitigating device
- For electromechanical lock-out relays, electrical operation of electromechanical trip

Every 12 calendar years, verify the following:

- Microprocessor relay settings are as specified
- Operation of the microprocessor's relay inputs and outputs that are essential to proper functioning of the Protection System
- Acceptable measurement of power System input values seen by the microprocessor protective relay
- Verify that current and voltage signal values are provided to the protective relays
- Protection System component monitoring for the battery system signals are conveyed to a location where corrective action can be initiated
- The microprocessor relay alarm signals are conveyed to a location where corrective action can be initiated
- Verify all trip paths in the control circuitry associated with protective functions through the trip coil(s) of the circuit breakers or other interrupting devices
- Auxiliary outputs that are in the trip path shall be maintained as detailed in Table 1-5 of the standard under the 'Unmonitored Control Circuitry Associated with Protective Functions' section'
- Auxiliary outputs not in a trip path (i.e., annunciation or DME input) are not required, by this standard, to be checked

Example #2: A combination of monitored and unmonitored components within a given Protection System might be:

- A microprocessor relay with integral alarm that is not connected to SCADA. (unmonitored)
- Current and voltage signal values, with no monitoring, connected as inputs to that relay. (unmonitored)
- A vented lead-acid battery with a low voltage alarm for the station dc supply voltage and an unintentional grounds detection alarm connected to SCADA. (monitoring varies)
- A circuit breaker with a trip coil, with no circuits monitored. (unmonitored)

Given the particular components and conditions, and using the Table 1 (Maximum Allowable Testing Intervals and Maintenance Activities) and Table 2 (Alarming Paths and Monitoring), the particular components have maximum activity intervals of:

Every four calendar months, inspect:

-
- Electrolyte level (station dc supply voltage and unintentional ground detection is being maintained more frequently by the monitoring system)

Every 18 calendar months, verify/inspect the following:

- Battery bank trending of ohmic values or other measurements indicative of battery performance to station battery baseline (if performance tests are not opted)
- Battery charger float voltage
- Battery rack integrity
- Cell condition of all individual battery cells (where visible)
- Battery continuity
- Battery terminal connection resistance
- Battery cell-to-cell resistance (where available to measure)

Every six calendar years, verify/perform the following:

- Verify operation of the relay inputs and outputs that are essential to proper functioning of the Protection System
- Verify acceptable measurement of power system input values as seen by the relays
- Verify that each trip coil is able to operate the circuit breaker, interrupting device, or mitigating device
- For electromechanical lock-out relays, electrical operation of electromechanical trip
- Battery performance test (if internal ohmic tests are not opted)

Every 12 calendar years, verify the following:

- Current and voltage signal values are provided to the protective relays
- Protection System component monitoring for the battery system signals are conveyed to a location where corrective action can be initiated
- All trip paths in the control circuitry associated with protective functions through the trip coil(s) of the circuit breakers or other interrupting devices
- Auxiliary outputs that are in the trip path shall be maintained, as detailed in Table 1-5 of the standard under the Unmonitored Control Circuitry Associated with Protective Functions" section
- Auxiliary outputs not in a trip path (i.e., annunciation or DME input) are not required, by this standard, to be checked

Example #3: A combination of monitored and unmonitored components within a given Protection System might be:

- A microprocessor relay with alarm connected to SCADA to alert 24-hr staffed operations center; it has internal self-diagnosis and alarms. (monitored)

-
- Current and voltage signal values, with monitoring, connected as inputs to that relay (monitored)
 - Vented Lead-Acid battery without any alarms connected to SCADA (unmonitored)
 - Circuit breaker with a trip coil, with no circuits monitored (unmonitored)

Given the particular components, conditions, and using the Table 1 (Maximum Allowable Testing Intervals and Maintenance Activities) and Table 2 (Alarming Paths and Monitoring), the particular components shall have maximum activity intervals of:

Every four calendar months, verify/inspect the following:

- Station dc supply voltage
- For unintentional grounds
- Electrolyte level

Every 18 calendar months, verify/inspect the following:

- Battery bank trending of ohmic values or other measurements indicative of battery performance to station battery baseline (if performance tests are not opted)
- Battery charger float voltage
- Battery rack integrity
- Battery continuity
- Battery terminal connection resistance
- Battery cell-to-cell resistance (where available to measure)
- Condition of all individual battery cells (where visible)

Every six calendar years, perform/verify the following:

- Battery performance test (if internal ohmic tests or other measurements indicative of battery performance are not opted)
- Verify that each trip coil is able to operate the circuit breaker, interrupting device, or mitigating device
- For electromechanical lock-out relays, electrical operation of electromechanical trip

Every 12 calendar years, verify the following:

- The microprocessor relay alarm signals are conveyed to a location where corrective action can be taken
- Microprocessor relay settings are as specified
- Operation of the microprocessor's relay inputs and outputs that are essential to proper functioning of the Protection System
- Acceptable measurement of power system input values seen by the microprocessor protective relay
- Verify all trip paths in the control circuitry associated with protective functions through the trip coil(s) of the circuit breakers or other interrupting devices

-
- Auxiliary outputs that are in the trip path shall be maintained, as detailed in Table 1-5 of the standard under the Unmonitored Control Circuitry Associated with Protective Functions section
 - Auxiliary outputs not in a trip path (i.e. annunciation or DME input) are not required, by this standard, to be checked

Why do components have different maintenance activities and intervals if they are monitored?

The intent behind different activities and intervals for monitored equipment is to allow less frequent manual intervention when more information is known about the condition of Protection System components. Condition-Based Maintenance is a valuable asset to improve reliability.

Can all components in a Protection System be monitored?

No. For some components in a Protection System, monitoring will not be relevant. For example, a battery will always need some kind of inspection.

We have a 30-year-old oil circuit breaker with a red indicating lamp on the substation relay panel that is illuminated only if there is continuity through the breaker trip coil. There is no SCADA monitor or relay monitor of this trip coil. The line protection relay package that trips this circuit breaker is a microprocessor relay that has an integral alarm relay that will assert on a number of conditions that includes a loss of power to the relay. This alarm contact connects to our SCADA system and alerts our 24-hour operations center of relay trouble when the alarm contact closes. This microprocessor relay trips the circuit breaker only and does not monitor trip coil continuity or other things such as trip current. Are the components monitored or not? How often must I perform maintenance?

The protective relay is monitored and can be maintained every 12 years, or when an Unresolved Maintenance Issue arises. The control circuitry can be maintained every 12 years. The circuit breaker trip coil(s) has to be electrically operated at least once every six years.

What is a mitigating device?

A mitigating device is the device that acts to respond as directed by a Remedial Action Schemes. It may be a breaker, valve, distributed control system, or any variety of other devices. This response may include tripping, closing, or other control actions.

8. Maximum Allowable Verification Intervals

The maximum allowable testing intervals and maintenance activities show how CBM with newer device types can reduce the need for many of the tests and site visits that older Protection System components require. As explained below, there are some sections of the Protection System that monitoring or data analysis may not verify. Verifying these sections of the Protection System or Automatic Reclosing requires some persistent TBM activity in the maintenance program. However, some of this TBM can be carried out remotely - for example, exercising a circuit breaker through the relay tripping circuits using the relay remote control capabilities can be used to verify function of one tripping path and proper trip coil operation, if there has been no Fault or routine operation to demonstrate performance of relay tripping circuits.

8.1 Maintenance Tests

Periodic maintenance testing is performed to ensure that the protection and control system is operating correctly after a time period of field installation. These tests may be used to ensure that individual components are still operating within acceptable performance parameters - this type of test is needed for components susceptible to degraded or changing characteristics due to aging and wear. Full system performance tests may be used to confirm that the total Protection System functions from measurement of power system values, to properly identifying Fault characteristics, to the operation of the interrupting devices.

8.1.1 Table of Maximum Allowable Verification Intervals

Table 1 (collectively known as Table 1, individually called out as Tables 1-1 through 1-5), Table 2, Table 3, Table 4-1 through Table 4-3, and Table 5 in the standard specify maximum allowable verification intervals for various generations of Protection Systems, Automatic Reclosing and Sudden Pressure Relaying and categories of equipment that comprise these systems. The right column indicates maintenance activities required for each category.

The types of components are illustrated in [Figures 1](#) and [2](#) at the end of this paper. [Figure 1](#) shows an example of telecommunications-assisted transmission Protection System comprising substation equipment at each terminal and a telecommunications channel for relaying between the two substations. [Figure 2](#) shows an example of a generation Protection System. The various sub-systems of a Protection System that need to be verified are shown.

Non-distributed UFLS, UVLS, and RAS are additional categories of Table 1 that are not illustrated in these figures. Non-distributed UFLS, UVLS and RAS all use identical equipment as Protection Systems in the performance of their functions; and, therefore, have the same maintenance needs.

Distributed UFLS and UVLS Systems, which use local sensing on the distribution System and trip co-located non-BES interrupting devices, are addressed in Table 3 with reduced maintenance activities.

While it is easy to associate protective relays to multiple levels of monitoring, it is also true that most of the components that can make up a Protection System can also have technological advancements that place them into higher levels of monitoring.

To use the Maintenance Activities and Intervals Tables from PRC-005-4:

-
- First find the Table associated with your component. The tables are arranged in the order of mention in the definition of Protection System;
 - Table 1-1 is for protective relays,
 - Table 1-2 is for the associated communications systems,
 - Table 1-3 is for current and voltage sensing devices,
 - Table 1-4 is for station dc supply and
 - Table 1-5 is for control circuits.
 - Table 2, is for alarms; this was broken out to simplify the other tables.
 - Table 3 is for components which make-up distributed UFLS and UVLS Systems.
 - Table 4 is for Automatic Reclosing.
 - Table 5 is for Sudden Pressure Relaying.
 - Next look within that table for your device and its degree of monitoring. The Tables have different hands-on maintenance activities prescribed depending upon the degree to which you monitor your equipment. Find the maintenance activity that applies to the monitoring level that you have on your piece of equipment.
 - This Maintenance activity is the minimum maintenance activity that must be documented.
 - If your Performance-Based Maintenance (PBM) plan requires more activities, then you must perform and document to this higher standard. (Note that this does not apply unless you utilize PBM.)
 - After the maintenance activity is known, check the maximum maintenance interval; this time is the maximum time allowed between hands-on maintenance activity cycles of this component.
 - If your Performance-Based Maintenance plan requires activities more often than the Tables maximum, then you must perform and document those activities to your more stringent standard. (Note that this does not apply unless you utilize PBM.)
 - Any given component of a Protection System can be determined to have a degree of monitoring that may be different from another component within that same Protection System. For example, in a given Protection System it is possible for an entity to have a monitored protective relay and an unmonitored associated communications system; this combination would require hands-on maintenance activity on the relay at least once every 12 years and attention paid to the communications system as often as every four months.
 - An entity does not have to utilize the extended time intervals made available by this use of condition-based monitoring. An easy choice to make is to simply utilize the unmonitored level of maintenance made available in each of the Tables. While the maintenance activities resulting from this choice would require more maintenance man-

hours, the maintenance requirements may be simpler to document and the resulting maintenance plans may be easier to create.

For each Protection System Component, Table 1 shows maximum allowable testing intervals for the various degrees of monitoring. For each Automatic Reclosing Component, Table 4 shows maximum allowable testing intervals for the various degrees of monitoring. These degrees of monitoring, or levels, range from the legacy unmonitored through a system that is more comprehensively monitored.

It has been noted here that an entity may have a PSMP that is more stringent than PRC-005-4. There may be any number of reasons that an entity chooses a more stringent plan than the minimums prescribed within PRC-005-4, most notable of which is an entity using performance based maintenance methodology.

If an entity has a Performance-Based Maintenance program, then that plan must be followed, even if the plan proves to be more stringent than the minimums laid out in the Tables.

If an entity has a Time-Based Maintenance program and the PSMP is more stringent than PRC-005-4, they will only be audited in accordance with the standard (minimum maintenance activities and maximum maintenance intervals prescribed within Tables 1-1 through 1-5, Table 2, Table 3, Table 4-1 through 4-3, and Table 5).

8.1.2 Additional Notes for Tables 1-1 through 1-5, Table 3, and Table 4

1. For electromechanical relays, adjustment is required to bring measurement accuracy within the tolerance needed by the asset owner. Microprocessor relays with no remote monitoring of alarm contacts, etc., are unmonitored relays and need to be verified within the Table interval as other unmonitored relays but may be verified as functional by means other than testing by simulated inputs.
2. Microprocessor relays typically are specified by manufacturers as not requiring calibration, but acceptable measurement of power system input values must be verified (verification of the Analog to Digital [A/D] converters) within the Table intervals. The integrity of the digital inputs and outputs that are used as protective functions must be verified within the Table intervals.
3. Any Phasor Measurement Unit (PMU) function whose output is used in a Protection System or RAS (as opposed to a monitoring task) must be verified as a component in a Protection System.
4. In addition to verifying the circuitry that supplies dc to the Protection System, the owner must maintain the station dc supply. The most widespread station dc supply is the station battery and charger. Unlike most Protection System components, physical inspection of station batteries for signs of component failure, reduced performance, and degradation are required to ensure that the station battery is reliable enough to deliver dc power when required. IEEE Standards 450, 1188, and 1106 for vented lead-acid, valve-regulated lead-acid, and nickel-cadmium batteries, respectively (which are the most commonly used substation batteries on the NERC BES) have been developed as an important reference source of maintenance recommendations. The Protection System owner might want to follow the guidelines in the applicable IEEE recommended practices for battery maintenance and testing, especially if the battery in question is used for application requirements in addition to the protection and control demands covered under this

standard. However, the Standard Drafting Team has tailored the battery maintenance and testing guidelines in PRC-005-4 for the Protection System owner which are application specific for the BES Facilities. While the IEEE recommendations are all encompassing, PRC-005-4 is a more economical approach while addressing the reliability requirements of the BES.

5. Aggregated small entities might distribute the testing of the population of UFLS/UVLS systems, and large entities will usually maintain a portion of these systems in any given year. Additionally, if relatively small quantities of such systems do not perform properly, it will not affect the integrity of the overall program. Thus, these distributed systems have decreased requirements as compared to other Protection Systems.
6. Voltage & current sensing device circuit input connections to the Protection System relays can be verified by (but not limited to) comparison of measured values on live circuits or by using test currents and voltages on equipment out of service for maintenance. The verification process can be automated or manual. The values should be verified to be as expected (phase value and phase relationships are both equally important to verify).
7. “End-to-end test,” as used in this Supplementary Reference, is any testing procedure that creates a remote input to the local communications-assisted trip scheme. While this can be interpreted as a GPS-type functional test, it is not limited to testing via GPS. Any remote scheme manipulation that can cause action at the local trip path can be used to functionally-test the dc control circuitry. A documented Real-time trip of any given trip path is acceptable in lieu of a functional trip test. It is possible, with sufficient monitoring, to be able to verify each and every parallel trip path that participated in any given dc control circuit trip. Or another possible solution is that a single trip path from a single monitored relay can be verified to be the trip path that successfully tripped during a Real-time operation. The variations are only limited by the degree of engineering and monitoring that an entity desires to pursue.
8. A/D verification may use relay front panel value displays, or values gathered via data communications. Groupings of other measurements (such as vector summation of bus feeder currents) can be used for comparison if calibration requirements assure acceptable measurement of power system input values.
9. Notes 1-8 attempt to describe some testing activities; they do not represent the only methods to achieve these activities, but rather some possible methods. Technological advances, ingenuity and/or industry accepted techniques can all be used to satisfy maintenance activity requirements; the standard is technology- and method-neutral in most cases.

8.1.3 Frequently Asked Questions:

What is meant by “Verify that settings are as specified” maintenance activity in Table 1-1?

Verification of settings is an activity directed mostly towards microprocessor- based relays. For relay maintenance departments that choose to test microprocessor-based relays in the same manner as electromechanical relays are tested, the testing process sometimes requires that some specific functions be disabled. Later tests might enable the functions previously

disabled, but perhaps still other functions or logic statements were then masked out. It is imperative that, when the relay is placed into service, the settings in the relay be the settings that were intended to be in that relay or as the standard states “...settings are as specified.”

Many of the microprocessor- based relays available today have software tools which provide this functionality and generate reports for this purpose.

For evidence or documentation of this requirement, a simple recorded acknowledgement that the settings were checked to be as specified is sufficient.

The drafting team was careful not to require “...that the relay settings be correct...” because it was believed that this might then place a burden of proof that the specified settings would result in the correct intended operation of the interrupting device. While that is a noble intention, the measurable proof of such a requirement is immense. The intent is that settings of the component be as specified at the conclusion of maintenance activities, whether those settings may have “drifted” since the prior maintenance or whether changes were made as part of the testing process.

Are electromechanical relays included in the “Verify that settings are as specified” maintenance activity in Table 1-1?

Verification of settings is an activity directed towards the application of protection related functions of microprocessor based relays. Electromechanical relays require calibration verification by voltage and/or current injection; and, thus, the settings are verified during calibration activity. In the example of a time-overcurrent relay, a minor deviation in time dial, versus the settings, may be acceptable, as long as the relay calibration is within accepted tolerances at the injected current amplitudes. A major deviation may require further investigation, as it could indicate a problem with the relay or an incorrect relay style for the application.

The verification of phase current and voltage measurements by comparison to other quantities seems reasonable. How, though, can I verify residual or neutral currents, or 3V0 voltages, by comparison, when my system is closely balanced?

Since these inputs are verified at commissioning, maintenance verification requires ensuring that phase quantities are as expected and that 3IO and 3V0 quantities appear equal to or close to 0.

These quantities also may be verified by use of oscillographic records for connected microprocessor relays as recorded during system Disturbances. Such records may compare to similar values recorded at other locations by other microprocessor relays for the same event, or compared to expected values (from short circuit studies) for known Fault locations.

What does this Standard require for testing an auxiliary tripping relay?

Table 1 and Table 3 requires that a trip test must verify that the auxiliary tripping relay(s) and/or lockout relay(s) which are directly in a trip path from the protective relay to the interrupting device trip coil operate(s) electrically. Auxiliary outputs not in a trip path (i.e. annunciation or DME input) are not required, by this standard, to be checked.

Do I have to perform a full end-to-end test of a Remedial Action schemes?

No. All portions of the -RAS need to be maintained, and the portions must overlap, but the overall RAS does not need to have a single end-to-end test. In other words it may be tested in piecemeal fashion provided all of the pieces are verified.

What about RAS interfaces between different entities or owners?

As in all of the Protection System requirements, RAS segments can be tested individually, thus minimizing the need to accommodate complex maintenance schedules.

What do I have to do if I am using a phasor measurement unit (PMU) as part of a Protection System or Remedial Action Schemes?

Any Phasor Measurement Unit (PMU) function whose output is used in a Protection System or Remedial Action Schemes (as opposed to a monitoring task) must be verified as a component in a Protection System.

How do I maintain a Remedial Action Schemes or relay sensing for non-distributed UFLS or UVLS Systems?

Since components of the RAS, UFLS and UVLS are the same types of components as those in Protection Systems, then these components should be maintained like similar components used for other Protection System functions. In many cases the devices for RAS, UFLS and UVLS are also used for other protective functions. The same maintenance activities apply with the exception that distributed systems (UFLS and UVLS) have fewer dc supply and control circuitry maintenance activity requirements.

For the testing of the output action, verification may be by breaker tripping, but may be verified in overlapping segments. For example, an RAS that trips a remote circuit breaker might be tested by testing the various parts of the scheme in overlapping segments. Another method is to document the Real-time tripping of an RAS scheme should that occur. Forced trip tests of circuit breakers (etc.) that are a part of distributed UFLS or UVLS schemes are not required.

The established maximum allowable intervals do not align well with the scheduled outages for my power plant. Can I extend the maintenance to the next scheduled outage following the established maximum interval?

No. You must complete your maintenance within the established maximum allowable intervals in order to be compliant. You will need to schedule your maintenance during available outages to complete your maintenance as required, even if it means that you may do protective relay maintenance more frequently than the maximum allowable intervals. The maintenance intervals were selected with typical plant outages, among other things, in mind.

If I am unable to complete the maintenance, as required, due to a major natural disaster (hurricane, earthquake, etc.), how will this affect my compliance with this standard?

The Sanction Guidelines of the North American Electric Reliability Corporation, effective January 15, 2008, provides that the Compliance Monitor will consider extenuating circumstances when considering any sanctions.

What if my observed testing results show a high incidence of out-of-tolerance relays; or, even worse, I am experiencing numerous relay Misoperations due to the relays being out-of-tolerance?

The established maximum time intervals are mandatory only as a not-to-exceed limitation. The establishment of a maximum is measurable. But any entity can choose to test some or all of their Protection System components more frequently (or to express it differently, exceed the minimum requirements of the standard). Particularly if you find that the maximum intervals in the standard do not achieve your expected level of performance, it is understandable that you would maintain the related equipment more frequently. A high incidence of relay Misoperations is in no one's best interest.

We believe that the four-month interval between inspections is unnecessary. Why can we not perform these inspections twice per year?

The Standard Drafting Team, through the comment process, has discovered that routine monthly inspections are not the norm. To align routine station inspections with other important inspections, the four-month interval was chosen. In lieu of station visits, many activities can be accomplished with automated monitoring and alarming.

Our maintenance plan calls for us to perform routine protective relay tests every 3 years. If we are unable to achieve this schedule, but we are able to complete the procedures in less than the maximum time interval, then are we in or out of compliance?

According to R3, if you have a time-based maintenance program, then you will be in violation of the standard only if you exceed the maximum maintenance intervals prescribed in the Tables. According to R4, if your device in question is part of a Performance-Based Maintenance program, then you will be in violation of the standard if you fail to meet your PSMP, even if you do not exceed the maximum maintenance intervals prescribed in the Tables. The intervals in the Tables are associated with TBM and CBM; Attachment A is associated with PBM.

Please provide a sample list of devices or systems that must be verified in a generator, generator step-up transformer, generator connected station service or generator connected excitation transformer to meet the requirements of this maintenance standard.

Examples of typical devices and systems that may directly trip the generator, or trip through a lockout relay, may include, but are not necessarily limited to:

- Fault protective functions, including distance functions, voltage-restrained overcurrent functions, or voltage-controlled overcurrent functions
- Loss-of-field relays
- Volts-per-hertz relays
- Negative sequence overcurrent relays
- Over voltage and under voltage protection relays
- Stator-ground relays
- Communications-based Protection Systems such as transfer-trip systems
- Generator differential relays
- Reverse power relays
- Frequency relays

-
- Out-of-step relays
 - Inadvertent energization protection
 - Breaker failure protection

For generator step-up, generator-connected station service transformers, or generator connected excitation transformers, operation of any of the following associated protective relays frequently would result in a trip of the generating unit; and, as such, would be included in the program:

- Transformer differential relays
- Neutral overcurrent relay
- Phase overcurrent relays

Relays which trip breakers serving station auxiliary Loads such as pumps, fans, or fuel handling equipment, etc., need not be included in the program, even if the loss of the those Loads could result in a trip of the generating unit. Furthermore, relays which provide protection to secondary unit substation (SUS) or low switchgear transformers and relays protecting other downstream plant electrical distribution system components are not included in the scope of this program, even if a trip of these devices might eventually result in a trip of the generating unit. For example, a thermal overcurrent trip on the motor of a coal-conveyor belt could eventually lead to the tripping of the generator, but it does not cause the trip.

In the case where a plant does not have a generator connected station service transformer such that it is normally fed from a system connected station service transformer, is it still the drafting team's intent to exclude the Protection Systems for these system connected auxiliary transformers from scope even when the loss of the normal (system connected) station service transformer will result in a trip of a BES generating Facility?

The SDT does not intend that the system-connected station service transformers be included in the Applicability. The generator-connected station service transformers and generator connected excitation transformers are often connected to the generator bus directly without an interposing breaker; thus, the Protection Systems on these transformers will trip the generator as discussed in 4.2.5.1.

What is meant by "verify operation of the relay inputs and outputs that are essential to proper functioning of the Protection System?"

Any input or output (of the relay) that "affects the tripping" of the breaker is included in the scope of I/O of the relay to be verified. By "affects the tripping," one needs to realize that sometimes there are more inputs and outputs than simply the output to the trip coil. Many important protective functions include things like breaker fail initiation, zone timer initiation and sometimes even 52a/b contact inputs are needed for a protective relay to correctly operate.

Each input should be "picked up" or "turned on and off" and verified as changing state by the microprocessor of the relay. Each output should be "operated" or "closed and opened" from the microprocessor of the relay and the output should be verified to change state on the output

terminals of the relay. One possible method of testing inputs of these relays is to “jumper” the needed dc voltage to the input and verify that the relay registered the change of state.

Electromechanical lock-out relays (86) (used to convey the tripping current to the trip coils) need to be electrically operated to prove the capability of the device to change state. These tests need to be accomplished at least every six years, unless PBM methodology is applied.

The contacts on the 86 or auxiliary tripping relays (94) that change state to pass on the trip current to a breaker trip coil need only be checked every 12 years with the control circuitry.

What is the difference between a distributed UFLS/UVLS and a non-distributed UFLS/UVLS scheme?

A distributed UFLS or UVLS scheme contains individual relays which make independent Load shed decisions based on applied settings and localized voltage and/or current inputs. A distributed scheme may involve an enable/disable contact in the scheme and still be considered a distributed scheme. A non-distributed UFLS or UVLS scheme involves a system where there is some type of centralized measurement and Load shed decision being made. A non-distributed UFLS/UVLS scheme is considered similar to an RAS scheme and falls under Table 1 for maintenance activities and intervals.

8.2 Retention of Records

PRC-005-1 describes a reporting or auditing cycle of one year and retention of records for three years. However, with a three-year retention cycle, the records of verification for a Protection System might be discarded before the next verification, leaving no record of what was done if a Misoperation or failure is to be analyzed.

PRC-005-4 corrects this by requiring:

The Transmission Owner, Generator Owner, and Distribution Provider shall each keep data or evidence to show compliance as identified below unless directed by its Compliance Enforcement Authority to retain specific evidence for a longer period of time as part of an investigation.

For Requirement R1, the Transmission Owner, Generator Owner, and Distribution Provider shall each keep its current dated Protection System Maintenance Program, as well as any superseded versions since the preceding compliance audit, including the documentation that specifies the type of maintenance program applied for each Protection System, Automatic Reclosing, or Sudden Pressure Relaying Component Type.

For Requirement R2, Requirement R3, and Requirement R4, in cases where the interval of the maintenance activity is longer than the audit cycle, the Transmission Owner, Generator Owner, and Distribution Provider shall each keep documentation of the most recent performance of that maintenance activity for the Protection System, Automatic Reclosing, or Sudden Pressure Relaying Component. In cases where the interval of the maintenance activity is shorter than the audit cycle, documentation of all performances (in accordance with the tables) of that maintenance activity for the Protection System, Automatic Reclosing, or Sudden Pressure Relaying Component since the previous scheduled audit date shall be retained.

For Requirement R5 the Transmission Owner, Generator Owner, and Distribution Provider shall each keep documentation of Unresolved Maintenance Issues identified by the entity since the last audit, including all that were resolved since the last audit.

This requirement assures that the documentation shows that the interval between maintenance cycles correctly meets the maintenance interval limits. The requirement is actually alerting the industry to documentation requirements already implemented by audit teams. Evidence of compliance bookending the interval shows interval accomplished instead of proving only your planned interval.

The SDT is aware that, in some cases, the retention period could be relatively long. But, the retention of documents simply helps to demonstrate compliance.

8.2.1 Frequently Asked Questions:

Please clarify the data retention requirements.

The data retention requirements are intended to allow the availability of maintenance records to demonstrate that the time intervals in your maintenance plan were upheld.

<u>Maximum Maintenance Interval</u>	<u>Data Retention Period</u>
4 Months, 6 Months, 18 Months, or 3 Years	All activities since previous audit
6 Years	All activities since previous audit (assuming a 6 year audit cycle) or most recent performance (assuming 3 year audit cycle), whichever is longer
12 Year	All activities from the most recent performance

If an entity prefers to utilize Performance-Based Maintenance, then statistical data may well be retained for extended periods to assist with future adjustments in time intervals.

If an equipment item is replaced, then the entity can restart the maintenance-time-interval-clock if desired; however, the replacement of equipment does not remove any documentation requirements that would have been required to verify compliance with time-interval requirements. In other words, do not discard maintenance data that goes to verify your work.

The retention of documentation for new and/or replaced equipment is all about proving that the maintenance intervals had been in compliance. For example, a long-range plan of upgrades might lead an entity to ignore required maintenance; retaining the evidence of prior maintenance that existed before any retirements and upgrades proves compliance with the standard.

What does this Maintenance Standard say about commissioning? Is it necessary to have documentation in your maintenance history of the completion of commission testing?

This standard does not establish requirements for commission testing. Commission testing includes all testing activities necessary to conclude that a Facility has been built in accordance with design. While a thorough commission testing program would include, either directly or indirectly, the verification of all those Protection System attributes addressed by the

maintenance activities specified in the Tables of PRC-005-4, verification of the adequacy of initial installation necessitates the performance of testing and inspections that go well beyond these routine maintenance activities. For example, commission testing might set baselines for future tests; perform acceptance tests and/or warranty tests; utilize testing methods that are not generally done routinely like staged-Fault-tests.

However, many of the Protection System attributes which are verified during commission testing are not subject to age related or service related degradation, and need not be re-verified within an ongoing maintenance program. Example – it is not necessary to re-verify correct terminal strip wiring on an ongoing basis.

PRC-005-4 assumes that thorough commission testing was performed prior to a Protection System being placed in service. PRC-005-4 requires performance of maintenance activities that are deemed necessary to detect and correct plausible age and service related degradation of components, such that a properly built and commission tested Protection System will continue to function as designed over its service life.

It should be noted that commission testing frequently is performed by a different organization than that which is responsible for the ongoing maintenance of the Protection System. Furthermore, the commission testing activities will not necessarily correlate directly with the maintenance activities required by the standard. As such, it is very likely that commission testing records will deviate significantly from maintenance records in both form and content; and, therefore, it is not necessary to maintain commission testing records within the maintenance program documentation.

Notwithstanding the differences in records, an entity would be wise to retain commissioning records to show a maintenance start date. (See below). An entity that requires that their commissioning tests have, at a minimum, the requirements of PRC-005-4 would help that entity prove time interval maximums by setting the initial time clock.

How do you determine the initial due date for maintenance?

The initial due date for maintenance should be based upon when a Protection System was tested. Alternatively, an entity may choose to use the date of completion of the commission testing of the Protection System component and the system was placed into service as the starting point in determining its first maintenance due dates. Whichever method is chosen, for newly installed Protection Systems the components should not be placed into service until minimum maintenance activities have taken place.

It is conceivable that there can be a (substantial) difference in time between the date of testing, as compared to the date placed into service. The use of the “Calendar Year” language can help determine the next due date without too much concern about being non-compliant for missing test dates by a small amount (provided your dates are not already at the end of a year). However, if there is a substantial amount of time difference between testing and in-service dates, then the testing date should be followed because it is the degradation of components that is the concern. While accuracy fluctuations may decrease when components are not energized, there are cases when degradation can take place, even though the device is not energized. Minimizing the time between commissioning tests and in-service dates will help.

If I miss two battery inspections four times out of 100 Protection System components on my transmission system, does that count as 2% or 8% when counting Violation Severity Level (VSL) for R3?

The entity failed to complete its scheduled program on two of its 100 Protection System components, which would equate to 2% for application to the VSL Table for Requirement R3. This VSL is written to compare missed components to total components. In this case two components out of 100 were missed, or 2%.

How do I achieve a “grace period” without being out of compliance?

The objective here is to create a time extension within your own PSMP that still does not violate the maximum time intervals stated in the standard. Remember that the maximum time intervals listed in the Tables cannot be extended.

For the purposes of this example, concentrating on just unmonitored protective relays – Table 1-1 specifies a maximum time interval (between the mandated maintenance activities) of six calendar years. Your plan must ensure that your unmonitored relays are tested at least once every six calendar years. You could, within your PSMP, require that your unmonitored relays be tested every four calendar years, with a maximum allowable time extension of 18 calendar months. This allows an entity to have deadlines set for the auto-generation of work orders, but still has the flexibility in scheduling complex work schedules. This also allows for that 18 calendar months to act as a buffer, in effect a grace period within your PSMP, in the event of unforeseen events. You will note that this example of a maintenance plan interval has a planned time of four years; it also has a built-in time extension allowed within the PSMP, and yet does not exceed the maximum time interval allowed by the standard. So while there are no time extensions allowed beyond the standard, an entity can still have substantial flexibility to maintain their Protection System components.

8.3 Basis for Table 1 Intervals

When developing the original *Protection System Maintenance – A Technical Reference* in 2007, the SPCTF collected all available data from Regional Entities (REs) on time intervals recommended for maintenance and test programs. The recommendations vary widely in categorization of relays, defined maintenance actions, and time intervals, precluding development of intervals by averaging. The SPCTF also reviewed the 2005 Report [2] of the IEEE Power System Relaying Committee Working Group I-17 (Transmission Relay System Performance Comparison). Review of the I-17 report shows data from a small number of utilities, with no company identification or means of investigating the significance of particular results.

To develop a solid current base of practice, the SPCTF surveyed its members regarding their maintenance intervals for electromechanical and microprocessor relays, and asked the members to also provide definitively-known data for other entities. The survey represented 470 GW of peak Load, or 4% of the NERC peak Load. Maintenance interval averages were compiled by weighting reported intervals according to the size (based on peak Load) of the reporting utility. Thus, the averages more accurately represent practices for the large populations of Protection Systems used across the NERC regions.

The results of this survey with weighted averaging indicate maintenance intervals of five years for electromechanical or solid state relays, and seven years for unmonitored microprocessor relays.

A number of utilities have extended maintenance intervals for microprocessor relays beyond seven years, based on favorable experience with the particular products they have installed. To

provide a technical basis for such extension, the SPCTF authors developed a recommendation of 10 years using the Markov modeling approach from [1], as summarized in Section 8.4. The results of this modeling depend on the completeness of self-testing or monitoring. Accordingly, this extended interval is allowed by Table 1, only when such relays are monitored as specified in the attributes of monitoring contained in Tables 1-1 through 1-5 and Table 2. Monitoring is capable of reporting Protection System health issues that are likely to affect performance within the 10 year time interval between verifications.

It is important to note that, according to modeling results, Protection System availability barely changes as the maintenance interval is varied below the 10-year mark. Thus, reducing the maintenance interval does not improve Protection System availability. With the assumptions of the model regarding how maintenance is carried out, reducing the maintenance interval actually degrades Protection System availability.

8.4 Basis for Extended Maintenance Intervals for Microprocessor Relays

Table 1 allows maximum verification intervals that are extended based on monitoring level. The industry has experience with self-monitoring microprocessor relays that leads to the Table 1 value for a monitored relay, as explained in Section 8.3. To develop a basis for the maximum interval for monitored relays in their *Protection System Maintenance – A Technical Reference*, the SPCTF used the methodology of Reference [1], which specifically addresses optimum routine maintenance intervals. The Markov modeling approach of [1] is judged to be valid for the design and typical failure modes of microprocessor relays.

The SPCTF authors ran test cases of the Markov model to calculate two key probability measures:

- Relay Unavailability - the probability that the relay is out of service due to failure or maintenance activity while the power system Element to be protected is in service.
- Abnormal Unavailability - the probability that the relay is out of service due to failure or maintenance activity when a Fault occurs, leading to failure to operate for the Fault.

The parameter in the Markov model that defines self-monitoring capability is ST (for self-test). ST = 0 if there is no self-monitoring; ST = 1 for full monitoring. Practical ST values are estimated to range from .75 to .95. The SPCTF simulation runs used constants in the Markov model that were the same as those used in [1] with the following exceptions:

Sn, Normal tripping operations per hour = 21600 (reciprocal of normal Fault clearing time of 10 cycles)

Sb, Backup tripping operations per hour = 4320 (reciprocal of backup Fault clearing time of 50 cycles)

Rc, Protected component repairs per hour = 0.125 (8 hours to restore the power system)

Rt, Relay routine tests per hour = 0.125 (8 hours to test a Protection System)

Rr, Relay repairs per hour = 0.08333 (12 hours to complete a Protection System repair after failure)

Experimental runs of the model showed low sensitivity of optimum maintenance interval to these parameter adjustments.

The resulting curves for relay unavailability and abnormal unavailability versus maintenance interval showed a broad minimum (optimum maintenance interval) in the vicinity of 10 years –

the curve is flat, with no significant change in either unavailability value over the range of 9, 10, or 11 years. This was true even for a relay mean time between Failures (MTBF) of 50 years, much lower than MTBF values typically published for these relays. Also, the Markov modeling indicates that both the relay unavailability and abnormal unavailability actually become higher with more frequent testing. This shows that the time spent on these more frequent tests yields no failure discoveries that approach the negative impact of removing the relays from service and running the tests.

The PSMT SDT discussed the practical need for “time-interval extensions” or “grace periods” to allow for scheduling problems that resulted from any number of business contingencies. The time interval discussions also focused on the need to reflect industry norms surrounding Generator outage frequencies. Finally, it was again noted that FERC Order 693 demanded maximum time intervals. “Maximum time intervals” by their very term negates any “time-interval extension” or “grace periods.” To recognize the need to follow industry norms on Generator outage frequencies and accommodate a form of time-interval extension, while still following FERC Order 693, the Standard Drafting Team arrived at a six-year interval for the electromechanical relay, instead of the five-year interval arrived at by the SPCTF. The PSMT SDT has followed the FERC directive for a *maximum* time interval and has determined that no extensions will be allowed. Six years has been set for the maximum time interval between manual maintenance activities. This maximum time interval also works well for maintenance cycles that have been in use in generator plants for decades.

For monitored relays, the PSMT SDT notes that the SPCTF called for 10 years as the interval between maintenance activities. This 10-year interval was chosen, even though there was “...no significant change in unavailability value over the range of 9, 10, or 11 years. This was true even for a relay Mean Time between Failures (MTBF) of 50 years...” The Standard Drafting Team again sought to align maintenance activities with known successful practices and outage schedules. The Standard does not allow extensions on any component of the Protection System; thus, the maximum allowed interval for these components has been set to 12 years. Twelve years also fits well into the traditional maintenance cycles of both substations and generator plants.

Also of note is the Table’s use of the term “Calendar” in the column for “Maximum Maintenance Interval.” The PSMT SDT deemed it necessary to include the term “Calendar” to facilitate annual maintenance planning, scheduling and implementation. This need is the result of known occurrences of system requirements that could cause maintenance schedules to be missed by a few days or weeks. The PSMT SDT chose the term “Calendar” to preclude the need to have schedules be met to the day. An electromechanical protective relay that is maintained in year number one need not be revisited until six years later (year number seven). For example, a relay was maintained April 10, 2008; maintenance would need to be completed no later than December 31, 2014.

Though not a requirement of this standard, to stay in line with many Compliance Enforcement Agencies audit processes an entity should define, within their own PSMP, the entity’s use of terms like annual, calendar year, etc. Then, once this is within the PSMP, the entity should abide by their chosen language.

9. Performance-Based Maintenance Process

In lieu of using the Table 1 intervals, a Performance-Based Maintenance process may be used to establish maintenance intervals (*PRC-005 Attachment A Criteria for a Performance-Based Protection System Maintenance Program*). A Performance-Based Maintenance process may justify longer maintenance intervals, or require shorter intervals relative to Table 1. In order to use a Performance-Based Maintenance process, the documented maintenance program must include records of repairs, adjustments, and corrections to covered Protection Systems in order to provide historical justification for intervals, other than those established in Table 1. Furthermore, the asset owner must regularly analyze these records of corrective actions to develop a ranking of causes. Recurrent problems are to be highlighted, and remedial action plans are to be documented to mitigate or eliminate recurrent problems.

Entities with Performance-Based Maintenance track performance of Protection Systems, demonstrate how they analyze findings of performance failures and aberrations, and implement continuous improvement actions. Since no maintenance program can ever guarantee that no malfunction can possibly occur, documentation of a Performance-Based Maintenance program would serve the utility well in explaining to regulators and the public a Misoperation leading to a major System outage event.

A Performance-Based Maintenance program requires auditing processes like those included in widely used industrial quality systems (such as *ISO 9001-2000, Quality Management Systems – Requirements*; or applicable parts of the NIST Baldrige National Quality Program). The audits periodically evaluate:

- The completeness of the documented maintenance process
- Organizational knowledge of and adherence to the process
- Performance metrics and documentation of results
- Remediation of issues
- Demonstration of continuous improvement.

In order to opt into a Performance-Based Maintenance (PBM) program, the asset owner must first sort the various Components into population segments. Any population segment must be comprised of at least 60 individual units; if any asset owner opts for PBM, but does not own 60 units to comprise a population, then that asset owner may combine data from other asset owners until the needed 60 units is aggregated. Each population segment must be composed of a grouping of Components of a consistent design standard or particular model or type from a single manufacturer and subjected to similar environmental factors. For example: One segment cannot be comprised of both GE & Westinghouse electro-mechanical lock-out relays; likewise, one segment cannot be comprised of 60 GE lock-out relays, 30 of which are in a dirty environment, and the remaining 30 from a clean environment. This PBM process cannot be applied to batteries, but can be applied to all other Components, including (but not limited to) specific battery chargers, instrument transformers, trip coils and/or control circuitry (etc.).

9.1 Minimum Sample Size

Large Sample Size

An assumption that needs to be made when choosing a sample size is “the sampling distribution of the sample mean can be approximated by a normal probability distribution.” The Central Limit Theorem states: “In selecting simple random samples of size n from a population, the sampling distribution of the sample mean \bar{x} can be approximated by a normal probability distribution as the sample size becomes large.” (Essentials of Statistics for Business and Economics, Anderson, Sweeney, Williams, 2003.)

To use the Central Limit Theorem in statistics, the population size should be large. The references below are supplied to help define what is large.

“... whenever we are using a large simple random sample (rule of thumb: $n \geq 30$), the central limit theorem enables us to conclude that the sampling distribution of the sample mean can be approximated by a normal distribution.” (Essentials of Statistics for Business and Economics, Anderson, Sweeney, Williams, 2003.)

“If samples of size n , when $n \geq 30$, are drawn from any population with a mean μ and a standard deviation σ , the sampling distribution of sample means approximates a normal distribution. The greater the sample size, the better the approximation.” (Elementary Statistics - Picturing the World, Larson, Farber, 2003.)

“The sample size is large (generally $n \geq 30$)... (Introduction to Statistics and Data Analysis - Second Edition, Peck, Olson, Devore, 2005.)

“... the normal is often used as an approximation to the t distribution in a test of a null hypothesis about the mean of a normally distributed population when the population variance is estimated from a relatively large sample. A sample size exceeding 30 is often given as a minimal size in this connection.” (Statistical Analysis for Business Decisions, Peters, Summers, 1968.)

Error of Distribution Formula

Beyond the large sample size discussion above, a sample size requirement can be estimated using the bound on the Error of Distribution Formula when the expected result is of a “Pass/Fail” format and will be between 0 and 1.0.

The Error of Distribution Formula is:

$$B = z \sqrt{\frac{\pi(1-\pi)}{n}}$$

Where:

B = bound on the error of distribution (allowable error)

z = standard error

π = expected failure rate

n = sample size required

Solving for n provides:

$$n = \pi(1 - \pi) \left(\frac{z}{B} \right)^2$$

Minimum Population Size to use Performance-Based Program

One entity's population of components should be large enough to represent a sizeable sample of a vendor's overall population of manufactured devices. For this reason, the following assumptions are made:

$$B = 5\%$$

$$z = 1.96 \text{ (This equates to a 95\% confidence level)}$$

$$\pi = 4\%$$

Using the equation above, n=59.0.

Minimum Sample Size to evaluate Performance-Based Program

The number of components that should be included in a sample size for evaluation of the appropriate testing interval can be smaller because a lower confidence level is acceptable since the sample testing is repeated or updated annually. For this reason, the following assumptions are made:

$$B = 5\%$$

$$z = 1.44 \text{ (85\% confidence level)}$$

$$\pi = 4\%$$

Using the equation above, n=31.8.

Recommendation

Based on the above discussion, a sample size should be at least 30 to allow use of the equation mentioned. Using this and the results of the equation, the following numbers are recommended (and required within the standard):

Minimum Population Size to use Performance-Based Maintenance Program = 60

Minimum Sample Size to evaluate Performance-Based Program = 30.

Once the population segment is defined, then maintenance must begin within the intervals as outlined for the device described in the Tables 1-1 through 1-5. Time intervals can be lengthened provided the last year's worth of components tested (or the last 30 units maintained, whichever is more) had fewer than 4% Countable Events. It is notable that 4% is specifically chosen because an entity with a small population (30 units) would have to adjust its time intervals between maintenance if more than one Countable Event was found to have occurred during the last analysis period. A smaller percentage would require that entity to adjust the time interval between maintenance activities if even one unit is found out of tolerance or causes a Misoperation.

The minimum number of units that can be tested in any given year is 5% of the population. Note that this 5% threshold sets a practical limitation on total length of time between intervals at 20 years.

If at any time the number of Countable Events equals or exceeds 4% of the last year's tested components (or the last 30 units maintained, whichever is more), then the time period between manual maintenance activities must be decreased. There is a time limit on reaching the decreased time at which the Countable Events is less than 4%; this must be attained within three years.

Performance-Based Program Evaluation Example

The 4% performance target was derived as a protection system performance target and was selected based on the drafting team's experience and studies performed by several utilities. This is not derived from the performance of discrete devices. Microprocessor relays and electromechanical relays have different performance levels. It is not appropriate to compare these performance levels to each other. The performance of the segment should be compared to the 4% performance criteria.

In consideration of the use of Performance Based Maintenance (PBM), the user should consider the effects of extended testing intervals and the established 4% failure rate. In the table shown below, the segment is 1000 units. As the testing interval (in years) increases, the number of units tested each year decreases. The number of countable events allowed is 4% of the tested units. Countable events are the failure of a Component requiring repair or replacement, any corrective actions performed during the maintenance test on the units within the testing segment (units per year), or any misoperation attributable to hardware failure or calibration failure found within the entire segment (1000 units) during the testing year.

Example: 1000 units in the segment with a testing interval of 8 years: The number of units tested each year will be 125 units. The total allowable countable events equals: $125 \times .04 = 5$. This number includes failure of a Component requiring repair or replacement, corrective issues found during testing, and the total number of misoperations (attributable to hardware or calibration failure within the testing year) associated with the entire segment of 1000 units.

Example: 1000 units in the segment with a testing interval of 16 years: The number of units tested each year will be 63 units. The total allowable countable events equals: $63 \times .04 = 2.5$.

As shown in the above examples, doubling the testing interval reduces the number of allowable events by half.

Total number of units in the segment	1000
Failure rate	4.00%

Testing Intervals (Years)	Units Per Year	Acceptable Number of Countable Events per year	Yearly Failure Rate Based on 1000 Units in Segment
1	1000.00	40.00	4.00%
2	500.00	20.00	2.00%
4	250.00	10.00	1.00%
6	166.67	6.67	0.67%
8	125.00	5.00	0.50%
10	100.00	4.00	0.40%
12	83.33	3.33	0.33%
14	71.43	2.86	0.29%
16	62.50	2.50	0.25%
18	55.56	2.22	0.22%
20	50.00	2.00	0.20%

Using the prior year’s data, determine the maximum allowable maintenance interval for each Segment such that the Segment experiences Countable Events on no more than 4% of the Components within the Segment, for the greater of either the last 30 Components maintained or all Components maintained in the previous year.

Segment – Components of a consistent design standard, or a particular model or type from a single manufacturer that typically share other common elements. Consistent performance is expected across the entire population of a Segment. A Segment must contain at least sixty (60) individual Components.

Countable Event – A failure of a Component requiring repair or replacement, any condition discovered during the maintenance activities in Tables 1-1 through 1-5, Table 3, Table 4-1 through Table 4-3, and Table 5, which requires corrective action or a Protection System Misoperation attributed to hardware failure or calibration failure. Misoperations due to product design errors, software errors, relay settings different from specified settings, Protection System Component, Automatic Reclosing, or Sudden Pressure Relaying configuration or application errors are not included in Countable Events.

9.2 Frequently Asked Questions:

I’m a small entity and cannot aggregate a population of Protection System components to establish a segment required for a Performance-Based Protection System Maintenance Program. How can I utilize that opportunity?

Multiple asset owning entities may aggregate their individually owned populations of individual Protection System components to create a segment that crosses ownership boundaries. All entities participating in a joint program should have a single documented joint management process, with consistent Protection System Maintenance Programs (practices, maintenance

intervals and criteria), for which the multiple owners are individually responsible with respect to the requirements of the Standard. The requirements established for Performance-Based Maintenance must be met for the overall aggregated program on an ongoing basis.

The aggregated population should reflect all factors that affect consistent performance across the population, including any relevant environmental factors such as geography, power-plant vs. substation, and weather conditions.

Can an owner go straight to a Performance-Based Maintenance program schedule, if they have previously gathered records?

Yes. An owner can go to a Performance-Based Maintenance program immediately. The owner will need to comply with the requirements of a Performance-Based Maintenance program as listed in the Standard. Gaps in the data collected will not be allowed; therefore, if an owner finds that a gap exists such that they cannot prove that they have collected the data as required for a Performance-Based Maintenance program then they will need to wait until they can prove compliance.

When establishing a Performance-Based Maintenance program, can I use test data from the device manufacturer, or industry survey results, as results to help establish a basis for my Performance-Based intervals?

No, you must use actual in-service test data for the components in the segment.

What types of Misoperations or events are not considered Countable Events In the Performance-Based Protection System Maintenance (PBM) Program?

Countable Events are intended to address conditions that are attributed to hardware failure or calibration failure; that is, conditions that reflect deteriorating performance of the component. These conditions include any condition where the device previously worked properly, then, due to changes within the device, malfunctioned or degraded to the point that re-calibration (to within the entity's tolerance) was required.

For this purpose of tracking hardware issues, human errors resulting in Protection System Misoperations during system installation or maintenance activities are not considered Countable Events. Examples of excluded human errors include relay setting errors, design errors, wiring errors, inadvertent tripping of devices during testing or installation, and misapplication of Protection System components. Examples of misapplication of Protection System components include wrong CT or PT tap position, protective relay function misapplication, and components not specified correctly for their installation. Obviously, if one is setting up relevant data about hardware failures then human failures should be eliminated from the hardware performance analysis.

One example of human-error is not pertinent data might be in the area of testing "86" lock-out relays (LOR). "Entity A" has two types of LOR's type "X" and type "Y"; they want to move into a performance based maintenance interval. They have 1000 of each type, so the population variables are met. During electrical trip testing of all of their various schemes over the initial six-year interval they find zero type "X" failures, but human error led to tripping a BES Element 100 times; they find 100 type "Y" failures and had an additional 100 human-error caused tripping incidents. In this example the human-error caused Misoperations should not be used to judge the performance of either type of LOR. Analysis of the data might lead "Entity A" to change time intervals. Type "X" LOR can be placed into extended time interval testing because of its low failure

rate (zero failures) while Type “Y” would have to be tested more often than every 6 calendar years (100 failures divided by 1000 units exceeds the 4% tolerance level).

Certain types of Protection System component errors that cause Misoperations are not considered Countable Events. Examples of excluded component errors include device malfunctions that are correctable by firmware upgrades and design errors that do not impact protection function.

What are some examples of methods of correcting segment performance for Performance-Based Maintenance?

There are a number of methods that may be useful for correcting segment performance for mal-performing segments in a Performance-Based Maintenance system. Some examples are listed below.

- The maximum allowable interval, as established by the Performance-Based Maintenance system, can be decreased. This may, however, be slow to correct the performance of the segment.
- Identifiable sub-groups of components within the established segment, which have been identified to be the mal-performing portion of the segment, can be broken out as an independent segment for target action. Each resulting segment must satisfy the minimum population requirements for a Performance-Based Maintenance program in order to remain within the program.
- Targeted corrective actions can be taken to correct frequently occurring problems. An example would be replacement of capacitors within electromechanical distance relays if bad capacitors were determined to be the cause of the mal-performance.
- components within the mal-performing segment can be replaced with other components (electromechanical distance relays with microprocessor relays, for example) to remove the mal-performing segment.

If I find (and correct) a Unresolved Maintenance Issue as a result of a Misoperation investigation (Re: PRC-004), how does this affect my Performance-Based Maintenance program?

If you perform maintenance on a Protection System component for any reason (including as part of a PRC-004 required Misoperation investigation/corrective action), the actions performed can count as a maintenance activity provided the activities in the relevant Tables have been done, and, if you desire, “reset the clock” on everything you’ve done. In a Performance-Based Maintenance program, you also need to record the Unresolved Maintenance Issue as a Countable Event within the relevant component group segment and use it in the analysis to determine your correct Performance-Based Maintenance interval for that component group. Note that “resetting the clock” should not be construed as interfering with an entity’s routine testing schedule because the “clock-reset” would actually make for a decreased time interval by the time the next routine test schedule comes around.

For example a relay scheme, consisting of four relays, is tested on 1-1-11 and the PSMP has a time interval of 3 calendar years with an allowable extension of 1 calendar year. The relay would be due again for routine testing before the end of the year 2015. This mythical relay scheme has a Misoperation on 6-1-12 that points to one of the four relays as bad. Investigation proves a bad relay and a new one is tested and installed in place of the original. This replacement relay actually

could be retested before the end of the year 2016 (clock-reset) and not be out of compliance. This requires tracking maintenance by individual relays and is allowed. However, many companies schedule maintenance in other ways like by substation or by circuit breaker or by relay scheme. By these methods of tracking maintenance that “replaced relay” will be retested before the end of the year 2015. This is also acceptable. In no case was a particular relay tested beyond the PSMP of four years max, nor was the 6 year max of the Standard exceeded. The entity can reset the clock if they desire or the entity can continue with original schedules and, in effect, test even more frequently.

Why are batteries excluded from PBM? What about exclusion of batteries from condition based maintenance?

Batteries are the only element of a Protection System that is a perishable item with a shelf life. As a perishable item batteries require not only a constant float charge to maintain their freshness (charge), but periodic inspection to determine if there are problems associated with their aging process and testing to see if they are maintaining a charge or can still deliver their rated output as required.

Besides being perishable, a second unique feature of a battery that is unlike any other Protection System element is that a battery uses chemicals, metal alloys, plastics, welds, and bonds that must interact with each other to produce the constant dc source required for Protection Systems, undisturbed by ac system Disturbances.

No type of battery manufactured today for Protection System application is free from problems that can only be detected over time by inspection and test. These problems can arise from variances in the manufacturing process, chemicals and alloys used in the construction of the individual cells, quality of welds and bonds to connect the components, the plastics used to make batteries and the cell forming process for the individual battery cells.

Other problems that require periodic inspection and testing can result from transportation from the factory to the job site, length of time before a charge is put on the battery, the method of installation, the voltage level and duration of equalize charges, the float voltage level used, and the environment that the battery is installed in.

All of the above mentioned factors and several more not discussed here are beyond the control of the Functional Entities that want to use a Performance-Based Protection System Maintenance (PBM) program. These inherent variances in the aging process of a battery cell make establishment of a designated segment based on manufacturer and type of battery impossible.

The whole point of PBM is that if all variables are isolated then common aging and performance criteria would be the same. However, there are too many variables in the electrochemical process to completely isolate all of the performance-changing criteria.

Similarly, Functional Entities that want to establish a condition-based maintenance program using the highest levels of monitoring, resulting in the least amount of hands-on maintenance activity, cannot completely eliminate some periodic maintenance of the battery used in a station dc supply. Inspection of the battery is required on a Maximum Maintenance Interval listed in the tables due to the aging processes of station batteries. However, higher degrees of

monitoring of a battery can eliminate the requirement for some periodic testing and some inspections (see Table 1-4).

Please provide an example of the calculations involved in extending maintenance time intervals using PBM.

Entity has 1000 GE-HEA lock-out relays; this is greater than the minimum sample requirement of 60. They start out testing all of the relays within the prescribed Table requirements (6 year max) by testing the relays every 5 years. The entity's plan is to test 200 units per year; this is greater than the minimum sample size requirement of 30. For the sake of example only the following will show 6 failures per year, reality may well have different numbers of failures every year. PBM requires annual assessment of failures found per units tested. After the first year of tests the entity finds 6 failures in the 200 units tested. $6/200 = 3\%$ failure rate. This entity is now allowed to extend the maintenance interval if they choose. The entity chooses to extend the maintenance interval of this population segment out to 10 years. This represents a rate of 100 units tested per year; entity selects 100 units to be tested in the following year. After that year of testing these 100 units the entity again finds 6 failed units. $6/100 = 6\%$ failures. This entity has now exceeded the acceptable failure rate for these devices and must accelerate testing of all of the units at a higher rate such that the failure rate is found to be less than 4% per year; the entity has three years to get this failure rate down to 4% or less (per year). In response to the 6% failure rate, the entity decreases the testing interval to 8 years. This means that they will now test 125 units per year ($1000/8$). The entity has just two years left to get the test rate corrected.

After a year, they again find six failures out of the 125 units tested. $6/125 = 5\%$ failures. In response to the 5% failure rate, the entity decreases the testing interval to seven years. This means that they will now test 143 units per year ($1000/7$). The entity has just one year left to get the test rate corrected. After a year, they again find six failures out of the 143 units tested. $6/143 = 4.2\%$ failures.

(Note that the entity has tried five years and they were under the 4% limit and they tried seven years and they were over the 4% limit. They must be back at 4% failures or less in the next year so they might simply elect to go back to five years.)

Instead, in response to the 5% failure rate, the entity decreases the testing interval to six years. This means that they will now test 167 units per year ($1000/6$). After a year, they again find six failures out of the 167 units tested. $6/167 = 3.6\%$ failures. Entity found that they could maintain the failure rate at no more than 4% failures by maintaining the testing interval at six years or less. Entity chose six-year interval and effectively extended their TBM (five years) program by 20%.

A note of practicality is that an entity will probably be in better shape to lengthen the intervals between tests if the failure rate is less than 2%. But the requirements allow for annual adjustments, if the entity desires. As a matter of maintenance management, an ever-changing test rate (units tested/year) may be un-workable.

Note that the "5% of components" requirement effectively sets a practical limit of 20 year maximum PBM interval. Also of note is the "3 years" requirement; an entity might arbitrarily extend time intervals from six years to 20 years. In the event that an entity finds a failure rate greater than 4%, then the test rate must be accelerated such that within three years the failure rate must be brought back down to 4% or less.

Here is a table that demonstrates the values discussed:

Year #	Total Population (P)	Test Interval (I)	Units to be Tested (U= P/I)	# of Failures Found (F)	Failure Rate (=F/U)	Decision to Change Interval Yes or No	Interval Chosen
1	1000	5 yrs	200	6	3%	Yes	10 yrs
2	1000	10 yrs	100	6	6%	Yes	8 yrs
3	1000	8 yrs	125	6	5%	Yes	7 yrs
4	1000	7 yrs	143	6	4.2%	Yes	6 yrs
5	1000	6 yrs	167	6	3.6%	No	6 yrs

Please provide an example of the calculations involved in extending maintenance time intervals using PBM for control circuitry.

Note that the following example captures “Control Circuitry” as all of the trip paths associated with a particular trip coil of a circuit breaker. An entity is not restricted to this method of counting control circuits. Perhaps another method an entity would prefer would be to simply track every individual (parallel) trip path. Or perhaps another method would be to track all of the trip outputs from a specific (set) of relays protecting a specific element.

The designation of what constitutes a control circuit component is very dependent upon how an entity performs and tracks the testing of the control circuitry. Some entities test their control circuits on a breaker basis whereas others test their circuitry on a local zone of protection basis. Thus, entities are allowed the latitude to designate their own definitions of control circuit components. Another example of where the entity has some discretion on determining what constitutes a single component is the voltage and current sensing devices, where the entity may choose either to designate a full three-phase set of such devices or a single device as a single component.

And in Attachment A (PBM) the definition of Segment:

Segment –*Components of a consistent design standard, or a particular model or type from a single manufacturer that typically share other common elements. Consistent performance is expected across the entire population of a segment. A segment must contain at least sixty (60) individual components.*

Example:

Entity has 1,000 circuit breakers, all of which have two trip coils, for a total of 2,000 trip coils; if all circuitry was designed and built with a consistent (internal entity) standard, then this is greater than the minimum sample requirement of 60.

For the sake of further example, the following facts are given:

Half of all relay panels (500) were built 40 years ago by an outside contractor, consisted of asbestos wrapped 600V-insulation panel wiring, and the cables exiting the control house are THHN pulled in conduit direct to exactly half of all of the various circuit breakers. All of the relay panels and cable pulls were built with consistent standards and consistent performance standard expectations within the segment (which is greater than 60). Each relay panel has redundant microprocessor (MPC) relays (retrofitted); each MPC relay supplies an individual trip output to each of the two trip coils of the assigned circuit breaker.

Approximately 35 years ago, the entity developed their own internal construction crew and now builds all of their own relay panels from parts supplied from vendors that meet the entity’s specifications, including SIS 600V insulation wiring and copper-sheathed cabling within the direct conduits to circuit breakers. The construction crew uses consistent standards in the construction. This newer segment of their control circuitry population is different than the original segment, consistent (standards, construction and performance expectations) within the new segment and constitutes the remainder of the entity’s population (another 500 panels and the cabling to the remaining 500 circuit breakers). Each relay panel has redundant microprocessor (MPC) relays; each MPC relay supplies an individual trip output to each of the two trip coils of the assigned circuit breaker. Every trip path in this newer segment has a device that monitors the voltage directly across the trip contacts of the MPC relays and alarms via RTU and SCADA to the

operations control room. This monitoring device, when not in alarm, demonstrates continuity all the way through the trip coil, cabling and wiring back to the trip contacts of the MPC relay.

The entity is tracking 2,000 trip coils (each consisting of multiple trip paths) in each of these two segments. But half of all of the trip paths are monitored; therefore, the trip paths are continuously tested and the circuit will alarm when there is a failure. These alarms have to be verified every 12 years for correct operation.

The entity now has 1,000 trip coils (and associated trip paths) remaining that they have elected to count as control circuits. The entity has instituted a process that requires the verification of every trip path to each trip coil (one unit), including the electrical activation of the trip coil. (The entity notes that the trip coils will have to be tripped electrically more often than the trip path verification, and is taking care of this activity through other documentation of Real-time Fault operations.)

They start out testing all of the trip coil circuits within the prescribed Table requirements (12-year max) by testing the trip circuits every 10 years. The entity's plan is to test 100 units per year; this is greater than the minimum sample size requirement of 30. For the sake of example only, the following will show three failures per year; reality may well have different numbers of failures every year. PBM requires annual assessment of failures found per units tested. After the first year of tests, the entity finds three failures in the 100 units tested. $3/100 = 3\%$ failure rate.

This entity is now allowed to extend the maintenance interval, if they choose. The entity chooses to extend the maintenance interval of this population segment out to 20 years. This represents a rate of 50 units tested per year; entity selects 50 units to be tested in the following year. After that year of testing these 50 units, the entity again finds three failed units. $3/50 = 6\%$ failures.

This entity has now exceeded the acceptable failure rate for these devices and must accelerate testing of all of the units at a higher rate, such that the failure rate is found to be less than 4% per year; the entity has three years to get this failure rate down to 4% or less (per year).

In response to the 6% failure rate, the entity decreases the testing interval to 16 years. This means that they will now test 63 units per year ($1000/16$). The entity has just two years left to get the test rate corrected. After a year, they again find three failures out of the 63 units tested. $3/63 = 4.76\%$ failures.

In response to the >4% failure rate, the entity decreases the testing interval to 14 years. This means that they will now test 72 units per year ($1000/14$). The entity has just one year left to get the test rate corrected. After a year, they again find three failures out of the 72 units tested. $3/72 = 4.2\%$ failures.

(Note that the entity has tried 10 years, and they were under the 4% limit; and they tried 14 years, and they were over the 4% limit. They must be back at 4% failures or less in the next year, so they might simply elect to go back to 10 years.)

Instead, in response to the 4.2% failure rate, the entity decreases the testing interval to 12 years. This means that they will now test 84 units per year ($1000/12$). After a year, they again find three failures out of the 84 units tested. $3/84 = 3.6\%$ failures.

Entity found that they could maintain the failure rate at no more than 4% failures by maintaining the testing interval at 12 years or less. Entity chose 12-year interval, and effectively extended their TBM (10 years) program by 20%.

A note of practicality is that an entity will probably be in better shape to lengthen the intervals between tests if the failure rate is less than 2%. But the requirements allow for annual adjustments if the entity desires. As a matter of maintenance management, an ever-changing test rate (units tested / year) may be un-workable.

Note that the “5% of components” requirement effectively sets a practical limit of 20-year maximum PBM interval. Also of note is the “3 years” requirement; an entity might arbitrarily extend time intervals from six years to 20 years. In the event that an entity finds a failure rate greater than 4%, then the test rate must be accelerated such that within three years the failure rate must be brought back down to 4% or less.

Here is a table that demonstrates the values discussed:

Year #	Total Population (P)	Test Interval (I)	Units to be Tested (U= P/I)	# of Failures Found (F)	Failure Rate (=F/U)	Decision to Change Interval Yes or No	Interval Chosen
1	1000	10 yrs	100	3	3%	Yes	20 yrs
2	1000	20 yrs	50	3	6%	Yes	16yrs
3	1000	16 yrs	63	3	4.8%	Yes	14 yrs
4	1000	14 yrs	72	3	4.2%	Yes	12 yrs
5	1000	12 yrs	84	3	3.6%	No	12 yrs

Please provide an example of the calculations involved in extending maintenance time intervals using PBM for voltage and current sensing devices.

Note that the following example captures “voltage and current inputs to the protective relays” as all of the various current transformer and potential transformer signals associated with a particular set of relays used for protection of a specific Element. This entity calls this set of protective relays a “Relay Scheme.” Thus, this entity chooses to count PT and CT signals as a group instead of individually tracking maintenance activities to specific bushing CT’s or specific PT’s. An entity is not restricted to this method of counting voltage and current devices, signals and paths. Perhaps another method an entity would prefer would be to simply track every individual PT and CT. Note that a generation maintenance group may well select the latter because they may elect to perform routine off-line tests during generator outages, whereas a transmission maintenance group might create a process that utilizes Real-time system values measured at the relays.

The designation of what constitutes a control circuit component is very dependent upon how an entity performs and tracks the testing of the control circuitry. Some entities test their control circuits on a breaker basis whereas others test their circuitry on a local zone of protection basis. Thus, entities are allowed the latitude to designate their own definitions of control circuit components. Another example of where the entity has some discretion on determining what constitutes a single component is the voltage and current sensing devices, where the entity may choose either to designate a full three-phase set of such devices or a single device as a single component.

And in Attachment A (PBM) the definition of Segment:

Segment –*Components of a consistent design standard, or a particular model or type from a single manufacturer that typically share other common elements. Consistent performance is expected across the entire population of a segment. A segment must contain at least sixty (60) individual components.*

Example:

Entity has 2000 “Relay Schemes,” all of which have three current signals supplied from bushing CTs, and three voltage signals supplied from substation bus PT’s. All cabling and circuitry was designed and built with a consistent (internal entity) standard, and this population is greater than the minimum sample requirement of 60.

For the sake of further example the following facts are given:

Half of all relay schemes (1,000) are supplied with current signals from ANSI STD C800 bushing CTs and voltage signals from PTs built by ACME Electric MFR CO. All of the relay panels and cable pulls were built with consistent standards, and consistent performance standard expectations exist for the consistent wiring, cabling and instrument transformers within the segment (which is greater than 60).

The other half of the entity’s relay schemes have MPC relays with additional monitoring built-in that compare DNP values of voltages and currents (or Watts and VARs), as interpreted by the MPC relays and alarm for an entity-accepted tolerance level of accuracy. This newer segment of their “Voltage and Current Sensing” population is different than the original segment, consistent

(standards, construction and performance expectations) within the new segment and constitutes the remainder of the entity's population.

The entity is tracking many thousands of voltage and current signals within 2,000 relay schemes (each consisting of multiple voltage and current signals) in each of these two segments. But half of all of the relay schemes voltage and current signals are monitored; therefore, the voltage and current signals are continuously tested and the circuit will alarm when there is a failure; these alarms have to be verified every 12 years for correct operation.

The entity now has 1,000 relay schemes worth of voltage and current signals remaining that they have elected to count within their relay schemes designation. The entity has instituted a process that requires the verification of these voltage and current signals within each relay scheme (one unit).

(Please note - a problem discovered with a current or voltage signal found at the relay could be caused by anything from the relay, all the way to the signal source itself. Having many sources of problems can easily increase failure rates beyond the rate of failures of just one item (for example just PTs). It is the intent of the SDT to minimize failure rates of all of the equipment to an acceptable level; thus, any failure of any item that gets the signal from source to relay is counted. It is for this reason that the SDT chose to set the boundary at the ability of the signal to be delivered all the way to the relay.

The entity will start out measuring all of the relay scheme voltage and currents at the individual relays within the prescribed Table requirements (12 year max) by measuring the voltage and current values every 10 years. The entity's plan is to test 100 units per year; this is greater than the minimum sample size requirement of 30. For the sake of example only, the following will show three failures per year; reality may well have different numbers of failures every year. PBM requires annual assessment of failures found per units tested. After the first year of tests, the entity finds three failures in the 100 units tested. $3/100 = 3\%$ failure rate.

This entity is now allowed to extend the maintenance interval, if they choose. The entity chooses to extend the maintenance interval of this population segment out to 20 years. This represents a rate of 50 units tested per year; entity selects 50 units to be tested in the following year. After that year of testing these 50 units, the entity again finds three failed units. $3/50 = 6\%$ failures.

This entity has now exceeded the acceptable failure rate for these devices and must accelerate testing of all of the units at a higher rate, such that the failure rate is found to be less than 4% per year; the entity has three years to get this failure rate down to 4% or less (per year).

In response to the 6% failure rate, the entity decreases the testing interval to 16 years. This means that they will now test 63 units per year ($1000/16$). The entity has just two years left to get the test rate corrected. After a year, they again find three failures out of the 63 units tested. $3/63 = 4.76\%$ failures.

In response to the >4% failure rate, the entity decreases the testing interval to 14 years. This means that they will now test 72 units per year ($1000/14$). The entity has just one year left to get the test rate corrected. After a year, they again find three failures out of the 72 units tested. $3/72 = 4.2\%$ failures.

(Note that the entity has tried 10 years, and they were under the 4% limit; and they tried 14 years, and they were over the 4% limit. They must be back at 4% failures or less in the next year, so they might simply elect to go back to 10 years.)

Instead, in response to the 4.2% failure rate, the entity decreases the testing interval to 12 years. This means that they will now test 84 units per year (1,000/12). After a year, they again find three failures out of the 84 units tested. $3/84 = 3.6\%$ failures.

Entity found that they could maintain the failure rate at no more than 4% failures by maintaining the testing interval at 12 years or less. Entity chose 12-year interval and effectively extended their TBM (10 years) program by 20%.

A note of practicality is that an entity will probably be in better shape to lengthen the intervals between tests if the failure rate is less than 2%. But the requirements allow for annual adjustments, if the entity desires. As a matter of maintenance management, an ever-changing test rate (units tested/year) may be un-workable.

Note that the “5% of components” requirement effectively sets a practical limit of 20-year maximum PBM interval. Also of note is the “3 years” requirement; an entity might arbitrarily extend time intervals from six years to 20 years. In the event that an entity finds a failure rate greater than 4%, then the test rate must be accelerated such that within three years the failure rate must be brought back down to 4% or less.

Here is a table that demonstrates the values discussed:

Year #	Total Population (P)	Test Interval (I)	Units to be Tested (U= P/I)	# of Failures Found (F)	Failure Rate (=F/U)	Decision to Change Interval Yes or No	Interval Chose
1	1000	10 yrs	100	3	3%	Yes	20 yrs
2	1000	20 yrs	50	3	6%	Yes	16yrs
3	1000	16 yrs	63	3	4.8%	Yes	14 yrs
4	1000	14 yrs	72	3	4.2%	Yes	12 yrs
5	1000	12 yrs	84	3	3.6%	No	12 yrs

10. Overlapping the Verification of Sections of the Protection System

Tables 1-1 through 1-5 require that every Protection System component be periodically verified. One approach, but not the only method, is to test the entire protection scheme as a unit, from the secondary windings of voltage and current sources to breaker tripping. For practical ongoing verification, sections of the Protection System may be tested or monitored individually. The boundaries of the verified sections must overlap to ensure that there are no gaps in the verification. See Appendix A of this Supplementary Reference for additional discussion on this topic.

All of the methodologies expressed within this report may be combined by an entity, as appropriate, to establish and operate a maintenance program. For example, a Protection System may be divided into multiple overlapping sections with a different maintenance methodology for each section:

- Time-based maintenance with appropriate maximum verification intervals for categories of equipment, as given in the Tables 1-1 through 1-5;
- Monitoring as described in Tables 1-1 through 1-5;
- A Performance-Based Maintenance program as described in Section 9 above, or Attachment A of the standard;
- Opportunistic verification using analysis of Fault records, as described in Section 11

10.1 Frequently Asked Questions:

My system has alarms that are gathered once daily through an auto-polling system; this is not really a conventional SCADA system but does it meet the Table 1 requirements for inclusion as a monitored system?

Yes, provided the auto-polling that gathers the alarms reports those alarms to a location where the action can be initiated to correct the Unresolved Maintenance Issue. This location does not have to be the location of the engineer or the technician that will eventually repair the problem, but rather a location where the action can be initiated.

11. Monitoring by Analysis of Fault Records

Many users of microprocessor relays retrieve Fault event records and oscillographic records by data communications after a Fault. They analyze the data closely if there has been an apparent Misoperation, as NERC standards require. Some advanced users have commissioned automatic Fault record processing systems that gather and archive the data. They search for evidence of component failures or setting problems hidden behind an operation whose overall outcome seems to be correct. The relay data may be augmented with independently captured Digital Fault Recorder (DFR) data retrieved for the same event.

Fault data analysis comprises a legitimate CBM program that is capable of reducing the need for a manual time-interval based check on Protection Systems whose operations are analyzed. Even electromechanical Protection Systems instrumented with DFR channels may achieve some CBM benefit. The completeness of the verification then depends on the number and variety of Faults in the vicinity of the relay that produce relay response records and the specific data captured.

A typical Fault record will verify particular parts of certain Protection Systems in the vicinity of the Fault. For a given Protection System installation, it may or may not be possible to gather within a reasonable amount of time an ensemble of internal and external Fault records that completely verify the Protection System.

For example, Fault records may verify that the particular relays that tripped are able to trip via the control circuit path that was specifically used to clear that Fault. A relay or DFR record may indicate correct operation of the protection communications channel. Furthermore, other nearby Protection Systems may verify that they restrain from tripping for a Fault just outside their respective zones of protection. The ensemble of internal Fault and nearby external Fault event data can verify major portions of the Protection System, and reset the time clock for the Table 1 testing intervals for the verified components only.

What can be shown from the records of one operation is very specific and limited. In a panel with multiple relays, only the specific relay(s) whose operation can be observed without ambiguity should be used. Be careful about using Fault response data to verify that settings or calibration are correct. Unless records have been captured for multiple Faults close to either side of a setting boundary, setting or calibration could still be incorrect.

PMU data, much like DME data, can be utilized to prove various components of the Protection System. Obviously, care must be taken to attribute proof only to the parts of a Protection System that can actually be proven using the PMU or DME data.

If Fault record data is used to show that portions or all of a Protection System have been verified to meet Table 1 requirements, the owner must retain the Fault records used, and the maintenance-related conclusions drawn from this data and used to defer Table 1 tests, for at least the retention time interval given in Section 8.2.

11.1 Frequently Asked Questions:

I use my protective relays for Fault and Disturbance recording, collecting oscillographic records and event records via communications for Fault analysis to meet NERC and DME requirements. What are the maintenance requirements for the relays?

For relays used only as Disturbance Monitoring Equipment, NERC Standard PRC-018-1 R3 & R6 states the maintenance requirements and is being addressed by a standards activity that is revising PRC-002-1 and PRC-018-1. For protective relays “that are designed to provide protection for the BES,” this standard applies, even if they also perform DME functions.

12. Importance of Relay Settings in Maintenance Programs

In manual testing programs, many utilities depend on pickup value or zone boundary tests to show that the relays have correct settings and calibration. Microprocessor relays, by contrast, provide the means for continuously monitoring measurement accuracy. Furthermore, the relay digitizes inputs from one set of signals to perform all measurement functions in a single self-monitoring microprocessor system. These relays do not require testing or calibration of each setting.

However, incorrect settings may be a bigger risk with microprocessor relays than with older relays. Some microprocessor relays have hundreds or thousands of settings, many of which are critical to Protection System performance.

Monitoring does not check measuring element settings. Analysis of Fault records may or may not reveal setting problems. To minimize risk of setting errors after commissioning, the user should enforce strict settings data base management, with reconfirmation (manual or automatic) that the installed settings are correct whenever maintenance activity might have changed them; for background and guidance, see [5] in References.

Table 1 requires that settings must be verified to be as specified. The reason for this requirement is simple: With legacy relays (non-microprocessor protective relays), it is necessary to know the value of the intended setting in order to test, adjust and calibrate the relay. Proving that the relay works per specified setting was the de facto procedure. However, with the advanced microprocessor relays, it is possible to change relay settings for the purpose of verifying specific functions and then neglect to return the settings to the specified values. While there is no specific requirement to maintain a settings management process, there remains a need to verify that the settings left in the relay are the intended, specified settings. This need may manifest itself after any of the following:

- One or more settings are changed for any reason.
- A relay fails and is repaired or replaced with another unit.
- A relay is upgraded with a new firmware version.

12.1 Frequently Asked Questions:

How do I approach testing when I have to upgrade firmware of a microprocessor relay?

The entity should ensure that the relay continues to function properly after implementation of firmware changes. Some entities may have a R&D department that might routinely run acceptance tests on devices with firmware upgrades before allowing the upgrade to be installed. Other entities may rely upon the vigorous testing of the firmware OEM. An entity has the latitude to install devices and/or programming that they believe will perform to their satisfaction. If an entity should choose to perform the maintenance activities specified in the Tables following a firmware upgrade, then they may, if they choose, reset the time clock on that set of maintenance activities so that they would not have to repeat the maintenance on its regularly scheduled cycle.

(However, for simplicity in maintenance schedules, some entities may choose to not reset this time clock; it is merely a suggested option.)

If I upgrade my old relays, then do I have to maintain my previous equipment maintenance documentation?

If an equipment item is repaired or replaced, then the entity can restart the maintenance-activity-time-interval-clock, if desired; however, the replacement of equipment does not remove any documentation requirements. The requirements in the standard are intended to ensure that an entity has a maintenance plan, and that the entity adheres to minimum activities and maximum time intervals. The documentation requirements are intended to help an entity demonstrate compliance. For example, saving the dates and records of the last two maintenance activities is intended to demonstrate compliance with the interval. Therefore, if you upgrade or replace equipment, then you still must maintain the documentation for the previous equipment, thus demonstrating compliance with the time interval requirement prior to the replacement action.

We have a number of installations where we have changed our Protection System components. Some of the changes were upgrades, but others were simply system rating changes that merely required taking relays “out-of-service”. What are our responsibilities when it comes to “out-of-service” devices?

Assuming that your system up-rates, upgrades and overall changes meet any and all other requirements and standards, then the requirements of PRC-005-4 are simple – if the Protection System component performs a Protection System function, then it must be maintained. If the component no longer performs Protection System functions, then it does not require maintenance activities under the Tables of PRC-005-4. While many entities might physically remove a component that is no longer needed, there is no requirement in PRC-005-4 to remove such component(s). Obviously, prudence would dictate that an “out-of-service” device is truly made inactive. There are no record requirements listed in PRC-005-4 for Protection System components not used.

While performing relay testing of a protective device on our Bulk Electric System, it was discovered that the protective device being tested was either broken or out of calibration. Does this satisfy the relay testing requirement, even though the protective device tested bad, and may be unable to be placed back into service?

Yes, PRC-005-4 requires entities to perform relay testing on protective devices on a given maintenance cycle interval. By performing this testing, the entity has satisfied PRC-005-4 requirement, although the protective device may be unable to be returned to service under normal calibration adjustments. R5 states:

“R5. Each Transmission Owner, Generator Owner, and Distribution Provider shall demonstrate efforts to correct any identified Unresolved Maintenance Issues.”

Also, when a failure occurs in a Protection System, power system security may be comprised, and notification of the failure must be conducted in accordance with relevant NERC standards.

If I show the protective device out of service while it is being repaired, then can I add it back as a new protective device when it returns? If not, my relay testing history would show that I was out of compliance for the last maintenance cycle.

The maintenance and testing requirements (R5) state “...shall demonstrate efforts to correct any identified Unresolved Maintenance Issues...” The type of corrective activity is not stated; however, it could include repairs or replacements.

Your documentation requirements will increase, of course, to demonstrate that your device tested bad and had corrective actions initiated. Your regional entity might ask about the status of your corrective actions.

13. Self-Monitoring Capabilities and Limitations

Microprocessor relay proponents have cited the self-monitoring capabilities of these products for nearly 20 years. Theoretically, any element that is monitored does not need a periodic manual test. A problem today is that the community of manufacturers and users has not created clear documentation of exactly what is and is not monitored. Some unmonitored but critical elements are buried in installed systems that are described as self-monitoring.

To utilize the extended time intervals allowed by monitoring, the user must document that the monitoring attributes of the device match the minimum requirements listed in the Table 1.

Until users are able to document how all parts of a system which are required for the protective functions are monitored or verified (with help from manufacturers), they must continue with the unmonitored intervals established in Tables 1, 3, 4 and 5 and any associated sub-tables.

Going forward, manufacturers and users can develop mappings of the monitoring within relays, and monitoring coverage by the relay of user circuits connected to the relay terminals.

To enable the use of the most extensive monitoring (and never again have a hands-on maintenance requirement), the manufacturers of the microprocessor-based self-monitoring components in the Protection System should publish for the user a document or map that shows:

- How all internal elements of the product are monitored for any failure that could impact Protection System performance.
- Which connected circuits are monitored by checks implemented within the product; how to connect and set the product to assure monitoring of these connected circuits; and what circuits or potential problems are not monitored.

This manufacturer's information can be used by the registered entity to document compliance of the monitoring attributes requirements by:

- Presenting or referencing the product manufacturer's documents.
- Explaining in a system design document the mapping of how every component and circuit that is critical to protection is monitored by the microprocessor product(s) or by other design features.
- Extending the monitoring to include the alarm transmission Facilities through which failures are reported within a given time frame to allocate where action can be taken to initiate resolution of the alarm attributed to an Unresolved Maintenance Issue, so that failures of monitoring or alarming systems also lead to alarms and action.
- Documenting the plans for verification of any unmonitored components according to the requirements of Tables 1, 3, 4 and 5 and any associated sub-tables.

13.1 Frequently Asked Questions:

I can't figure out how to demonstrate compliance with the requirements for the highest level of monitoring of Protection Systems. Why does this Maintenance Standard describe a maintenance program approach I cannot achieve?

Demonstrating compliance with the requirements for the highest level of monitoring any particular component of Protection Systems is likely to be very involved, and may include detailed manufacturer documentation of complete internal monitoring within a device, comprehensive design drawing reviews, and other detailed documentation. This standard does not presume to specify what documentation must be developed; only that it must be documented.

There may actually be some equipment available that is capable of meeting these highest levels of monitoring criteria, in which case it may be maintained according to the highest level of monitoring shown on the Tables. However, even if there is no equipment available today that can meet this level of monitoring, the standard establishes the necessary requirements for when such equipment becomes available.

By creating a roadmap for development, this provision makes the standard technology-neutral. The Standard Drafting Team wants to avoid the need to revise the standard in a few years to accommodate technology advances that may be coming to the industry.

14. Notification of Protection System or Automatic Reclosing Failures

When a failure occurs in a Protection System or Automatic Reclosing, power system security may be compromised, and notification of the failure must be conducted in accordance with relevant NERC standard(s). Knowledge of the failure may impact the system operator's decisions on acceptable Loading conditions.

This formal reporting of the failure and repair status to the system operator by the Protection System or Automatic Reclosing owner also encourages the system owner to execute repairs as rapidly as possible. In some cases, a microprocessor relay or carrier set can be replaced in hours; wiring termination failures may be repaired in a similar time frame. On the other hand, a component in an electromechanical or early-generation electronic relay may be difficult to find and may hold up repair for weeks. In some situations, the owner may have to resort to a temporary protection panel, or complete panel replacement.

15. Maintenance Activities

Some specific maintenance activities are a requirement to ensure reliability. An example would be that a BES entity could be prudent in its protective relay maintenance, but if its battery maintenance program is lacking, then reliability could still suffer. The NERC glossary outlines a Protection System as containing specific components. PRC-005-4 requires specific maintenance activities be accomplished within a specific time interval. As noted previously, higher technology equipment can contain integral monitoring capability that actually performs maintenance verification activities routinely and often; therefore, *manual intervention* to perform certain activities on these type components may not be needed.

15.1 Protective Relays (Table 1-1)

These relays are defined as the devices that receive the input signal from the current and voltage sensing devices and are used to isolate a Faulted Element of the BES. Devices that sense thermal, vibration, seismic, gas, or any other non-electrical inputs are excluded.

Non-microprocessor based equipment is treated differently than microprocessor-based equipment in the following ways; the relays should meet the asset owners' tolerances:

- Non-microprocessor devices must be tested with voltage and/or current applied to the device.
- Microprocessor devices may be tested through the integral testing of the device.
 - There is no specific protective relay commissioning test or relay routine test mandated.
 - There is no specific documentation mandated.

15.1.1 Frequently Asked Questions:

What calibration tolerance should be applied on electromechanical relays?

Each entity establishes their own acceptable tolerances when applying protective relaying on their system. For some Protection System components, adjustment is required to bring measurement accuracy within the parameters established by the asset owner based on the specific application of the component. A calibration failure is the result if testing finds the specified parameters to be out of tolerance.

15.2 Voltage & Current Sensing Devices (Table 1-3)

These are the current and voltage sensing devices, usually known as instrument transformers. There is presently a technology available (fiber-optic Hall-effect) that does not utilize conventional transformer technology; these devices and other technologies that produce quantities that represent the primary values of voltage and current are considered to be a type of voltage and current sensing devices included in this standard.

The intent of the maintenance activity is to verify the input to the protective relay from the device that produces the current or voltage signal sample.

There is no specific test mandated for these components. The important thing about these signals is to know that the expected output from these components actually reaches the protective relay. Therefore, the proof of the proper operation of these components also demonstrates the integrity of the wiring (or other medium used to convey the signal) from the current and voltage sensing device, all the way to the protective relay. The following observations apply:

- There is no specific ratio test, routine test or commissioning test mandated.
- There is no specific documentation mandated.
- It is required that the signal be present at the relay.
- This expectation can be arrived at from any of a number of means; including, but not limited to, the following: By calculation, by comparison to other circuits, by commissioning tests, by thorough inspection, or by any means needed to verify the circuit meets the asset owner's Protection System maintenance program.
- An example of testing might be a saturation test of a CT with the test values applied at the relay panel; this, therefore, tests the CT, as well as the wiring from the relay all the back to the CT.
- Another possible test is to measure the signal from the voltage and/or current sensing devices, during Load conditions, at the input to the relay.
- Another example of testing the various voltage and/or current sensing devices is to query the microprocessor relay for the Real-time Loading; this can then be compared to other devices to verify the quantities applied to this relay. Since the input devices have supplied the proper values to the protective relay, then the verification activity has been satisfied. Thus, event reports (and oscillographs) can be used to verify that the voltage and current sensing devices are performing satisfactorily.
- Still another method is to measure total watts and VARs around the entire bus; this should add up to zero watts and zero VARs, thus proving the voltage and/or current sensing devices system throughout the bus.
- Another method for proving the voltage and/or current-sensing devices is to complete commissioning tests on all of the transformers, cabling, fuses and wiring.
- Any other method that verifies the input to the protective relay from the device that produces the current or voltage signal sample.

15.2.1 Frequently Asked Questions:

What is meant by "... verify the current and voltage circuit inputs from the voltage and current sensing devices to the protective relays ..." Do we need to perform ratio, polarity and saturation tests every few years?

No. You must verify that the protective relay is receiving the expected values from the voltage and current-sensing devices (typically voltage and current transformers). This can be as difficult as is proposed by the question (with additional testing on the cabling and substation wiring to ensure that the values arrive at the relays); or simplicity can be achieved by other verification methods. While some examples follow, these are not intended to represent an all-inclusive list; technology advances and ingenuity should not be excluded from making comparisons and verifications:

- Compare the secondary values, at the relay, to a metering circuit, fed by different current transformers, monitoring the same line as the questioned relay circuit.
- Compare the individual phase secondary values at the relay panel (with additional testing on the panel wiring to ensure that the values arrive at those relays) with the other phases, and verify that residual currents are within expected bounds.
- Observe all three phase currents and the residual current at the relay panel with an oscilloscope, observing comparable magnitudes and proper phase relationship, with additional testing on the panel wiring to ensure that the values arrive at the relays.
- Compare the values, as determined by the questioned relay (such as, but not limited to, a query to the microprocessor relay) to another protective relay monitoring the same line, with currents supplied by different CTs.
- Compare the secondary values, at the relay with values measured by test instruments (such as, but not limited to multi-meters, voltmeter, clamp-on ammeters, etc.) and verified by calculations and known ratios to be the values expected. For example, a single PT on a 100KV bus will have a specific secondary value that, when multiplied by the PT ratio, arrives at the expected bus value of 100KV.
- Query SCADA for the power flows at the far end of the line protected by the questioned relay, compare those SCADA values to the values as determined by the questioned relay.
- Totalize the Watts and VARs on the bus and compare the totals to the values as seen by the questioned relay.

The point of the verification procedure is to ensure that all of the individual components are functioning properly; and that an ongoing proactive procedure is in place to re-check the various components of the protective relay measuring Systems.

Is wiring insulation or hi-pot testing required by this Maintenance Standard?

No, wiring insulation and equipment hi-pot testing are not specifically required by the Maintenance Standard. However, if the method of verifying CT and PT inputs to the relay involves some other method than actual observation of current and voltage transformer secondary inputs to the relay, it might be necessary to perform some sort of cable integrity test to verify that the instrument transformer secondary signals are actually making it to the relay and not being

shunted off to ground. For instance, you could use CT excitation tests and PT turns ratio tests and compare to baseline values to verify that the instrument transformer outputs are acceptable. However, to conclude that these acceptable transformer instrument output signals are actually making it to the relay inputs, it also would be necessary to verify the insulation of the wiring between the instrument transformer and the relay.

My plant generator and transformer relays are electromechanical and do not have metering functions, as do microprocessor-based relays. In order for me to compare the instrument transformer inputs to these relays to the secondary values of other metered instrument transformers monitoring the same primary voltage and current signals, it would be necessary to temporarily connect test equipment, like voltmeters and clamp on ammeters, to measure the input signals to the relays. This practice seems very risky, and a plant trip could result if the technician were to make an error while measuring these current and voltage signals. How can I avoid this risk? Also, what if no other instrument transformers are available which monitor the same primary voltage or current signal?

Comparing the input signals to the relays to the outputs of other independent instrument transformers monitoring the same primary current or voltage is just one method of verifying the instrument transformer inputs to the relays, but is not required by the standard. Plants can choose how to best manage their risk. If online testing is deemed too risky, offline tests, such as, but not limited to, CT excitation test and PT turns ratio tests can be compared to baseline data and be used in conjunction with CT and PT secondary wiring insulation verification tests to adequately “verify the current and voltage circuit inputs from the voltage and current sensing devices to the protective relays ...” while eliminating the risk of tripping an in service generator or transformer. Similarly, this same offline test methodology can be used to verify the relay input voltage and current signals to relays when there are no other instrument transformers monitoring available for purposes of signal comparison.

15.3 Control circuitry associated with protective functions (Table 1-5)

This component of Protection Systems includes the trip coil(s) of the circuit breaker, circuit switcher or any other interrupting device. It includes the wiring from the batteries to the relays. It includes the wiring (or other signal conveyance) from every trip output to every trip coil. It includes any device needed for the correct processing of the needed trip signal to the trip coil of the interrupting device; this requirement is meant to capture inputs and outputs to and from a protective relay that are necessary for the correct operation of the protective functions. In short, every trip path must be verified; the method of verification is optional to the asset owner. An example of testing methods to accomplish this might be to verify, with a volt-meter, the existence of the proper voltage at the open contacts, the open circuited input circuit and at the trip coil(s). As every parallel trip path has similar failure modes, each trip path from relay to trip coil must be verified. Each trip coil must be tested to trip the circuit breaker (or other interrupting device) at least once. There is a requirement to operate the circuit breaker (or other interrupting device) at least once every six years as part of the complete functional test. If a suitable monitoring system is installed that verifies every parallel trip path, then the manual-intervention testing of those parallel trip paths can be eliminated; however, the actual operation of the circuit breaker must still occur at least once every six years. This six-year tripping requirement can be completed as easily as tracking the Real-time Fault-clearing operations on the circuit breaker, or tracking the trip coil(s) operation(s) during circuit breaker routine maintenance actions.

The circuit-interrupting device should not be confused with a motor-operated disconnect. The intent of this standard is to require maintenance intervals and activities on Protection Systems equipment, and not just all system isolating equipment.

It is necessary, however, to classify a device that actuates a high-speed auto-closing ground switch as an interrupting device, if this ground switch is utilized in a Protection System and forces a ground Fault to occur that then results in an expected Protection System operation to clear the forced ground Fault. The SDT believes that this is essentially a transferred-tripping device without the use of communications equipment. If this high-speed ground switch is “...designed to provide protection for the BES...” then this device needs to be treated as any other Protection System component. The control circuitry would have to be tested within 12 years, and any electromechanically operated device will have to be tested every six years. If the spring-operated ground switch can be disconnected from the solenoid triggering unit, then the solenoid triggering unit can easily be tested without the actual closing of the ground blade.

The dc control circuitry also includes each auxiliary tripping relay (94) and each lock-out relay (86) that may exist in any particular trip scheme. If the lock-out relays (86) are electromechanical type components, then they must be trip tested. The PSMT SDT considers these components to share some similarities in failure modes as electromechanical protective relays; as such, there is a six-year maximum interval between mandated maintenance tasks unless PBM is applied.

Contacts of the 86 and/or 94 that pass the trip current on to the circuit interrupting device trip coils will have to be checked as part of the 12 year requirement. Contacts of the 86 and/or 94 lock relay that operate non-BES interrupting devices are not required. Normally-open contacts that are not used to pass a trip signal and normally-closed contacts do not have to be verified. Verification of the tripping paths is the requirement.

New technology is also accommodated here; there are some tripping systems that have replaced the traditional hard-wired trip circuitry with other methods of trip-signal conveyance such as fiber-optics. It is the intent of the PSMT SDT to include this, and any other, technology that is used to convey a trip signal from a protective relay to a circuit breaker (or other interrupting device) within this category of equipment. The requirement for these systems is verification of the tripping path.

Monitoring of the control circuit integrity allows for no maintenance activity on the control circuit (excluding the requirement to operate trip coils and electromechanical lockout and/or tripping auxiliary relays). Monitoring of integrity means to monitor for continuity and/or presence of voltage on each trip path. For Ethernet or fiber-optic control systems, monitoring of integrity means to monitor communication ability between the relay and the circuit breaker.

15.3.1 Frequently Asked Questions:

Is it permissible to verify circuit breaker tripping at a different time (and interval) than when we verify the protective relays and the instrument transformers?

Yes, provided the entire Protective System is tested within the individual component’s maximum allowable testing intervals.

The Protection System Maintenance Standard describes requirements for verifying the tripping of circuit breakers. What is this telling me about maintenance of circuit breakers?

Requirements in PRC-005-4 are intended to verify the integrity of tripping circuits, including the breaker trip coil, as well as the presence of auxiliary supply (usually a battery) for energizing the trip coil if a protection function operates. Beyond this, PRC-005-4 sets no requirements for verifying circuit breaker performance, or for maintenance of the circuit breaker.

How do I test each dc Control Circuit trip path, as established in Table 1-5 "Protection System Control Circuitry (Trip coils and auxiliary relays)"?

Table 1-5 specifies that each breaker trip coil and lockout relays that carry trip current to a trip coil must be operated within the specified time period. The required operations may be via targeted maintenance activities, or by documented operation of these devices for other purposes such as Fault clearing.

Are high-speed ground switch trip coils included in the dc control circuitry?

Yes. PRC-005-4 includes high-speed grounding switch trip coils within the dc control circuitry to the degree that the initiating Protection Systems are characterized as "transmission Protection Systems."

Does the control circuitry and trip coil of a non-BES breaker, tripped via a BES protection component, have to be tested per Table 1.5? (Refer to Table 3 for examples 1 and 2)

Example 1: A non-BES circuit breaker that is tripped via a Protection System to which PRC-005-4 applies might be (but is not limited to) a 12.5KV circuit breaker feeding (non-black-start) radial Loads but has a trip that originates from an under-frequency (81) relay.

- The relay must be verified.
- The voltage signal to the relay must be verified.
- All of the relevant dc supply tests still apply.
- The unmonitored trip circuit between the relay and any lock-out or auxiliary relay must be verified every 12 years.
- The unmonitored trip circuit between the lock-out (or auxiliary relay) and the non-BES breaker does not have to be proven with an electrical trip.
- In the case where there is no lock-out or auxiliary tripping relay used, the trip circuit to the non-BES breaker does not have to be proven with an electrical trip.
- The trip coil of the non-BES circuit breaker does not have to be individually proven with an electrical trip.

Example 2: A Transmission Owner may have a non-BES breaker that is tripped via a Protection System to which PRC-005-4 applies, which may be (but is not limited to) a 13.8 KV circuit breaker feeding (non-black-start) radial Loads but has a trip that originates from a BES 115KV line relay.

- The relay must be verified
- The voltage signal to the relay must be verified
- All of the relevant dc supply tests still apply

-
- The unmonitored trip circuit between the relay and any lock-out (86) or auxiliary (94) relay must be verified every 12 years
 - The unmonitored trip circuit between the lock-out (86) (or auxiliary (94)) relay and the non-BES breaker does not have to be proven with an electrical trip
 - In the case where there is no lockout (86) or auxiliary (94) tripping relay used, the trip circuit to the non-BES breaker does not have to be proven with an electrical trip.
 - The trip coil of the non-BES circuit breaker does not have to be individually proven with an electrical trip

Example 3: A Generator Owner may have a non-BES circuit breaker that is tripped via a Protection System to which PRC-005-4 applies, such as the generator field breaker and low-side breakers on station service/excitation transformers connected to the generator bus.

Trip testing of the generator field breaker and low side station service/excitation transformer breaker(s) via lockout or auxiliary tripping relays are not required since these breakers may be associated with radially fed loads and are not considered to be BES breakers. An example of an otherwise non-BES circuit breaker that is tripped via a BES protection component might be (but is not limited to) a 6.9kV station service transformer source circuit breaker but has a trip that originates from a generator differential (87) relay.

- The differential relay must be verified.
- The current signals to the relay must be verified.
- All of the relevant dc supply tests still apply.
- The unmonitored trip circuit between the relay and any lock-out or auxiliary relay must be verified every 12 years.
- The unmonitored trip circuit between the lock-out (or auxiliary relay) and the non-BES breaker does not have to be proven with an electrical trip.
- In the case where there is no lock-out or auxiliary tripping relay used, the trip circuit to the non-BES breaker does not have to be proven with an electrical trip.
- The trip coil of the non-BES circuit breaker does not have to be individually proven with an electrical trip.

However, it is very prudent to verify the tripping of such breakers for the integrity of the overall generation plant.

Do I have to verify operation of breaker "a" contacts or any other normally closed auxiliary contacts in the trip path of each breaker as part of my control circuit test?

Operation of normally-closed contacts does not have to be verified. Verification of the tripping paths is the requirement. The continuity of the normally closed contacts will be verified when the tripping path is verified.

15.4 Batteries and DC Supplies (Table 1-4)

The NERC definition of a Protection System is:

- Protective relays which respond to electrical quantities,

-
- Communications Systems necessary for correct operation of protective functions,
 - Voltage and current sensing devices providing inputs to protective relays,
 - Station dc supply associated with protective functions (including station batteries, battery chargers, and non-battery-based dc supply), and
 - Control circuitry associated with protective functions through the trip coil(s) of the circuit breakers or other interrupting devices.

The station battery is not the only component that provides dc power to a Protection System. In the new definition for Protection System, “station batteries” are replaced with “station dc supply” to make the battery charger and dc producing stored energy devices (that are not a battery) part of the Protection System that must be maintained.

The PSMT SDT recognizes that there are several technological advances in equipment and testing procedures that allow the owner to choose how to verify that a battery string is free of open circuits. The term “continuity” was introduced into the standard to allow the owner to choose how to verify continuity of a battery set by various methods, and not to limit the owner to other conventional methods of showing continuity. Continuity, as used in Table 1-4 of the standard, refers to verifying that there is a continuous current path from the positive terminal of the station battery set to the negative terminal. Without verifying continuity of a station battery, there is no way to determine that the station battery is available to supply dc power to the station. An open battery string will be an unavailable power source in the event of loss of the battery charger.

Batteries cannot be a unique population segment of a Performance-Based Maintenance Program (PBM) because there are too many variables in the electrochemical process to completely isolate all of the performance-changing criteria necessary for using PBM on battery Systems. However, nothing precludes the use of a PBM process for any other part of a dc supply besides the batteries themselves.

15.4.1 Frequently Asked Questions:

What constitutes the station dc supply, as mentioned in the definition of Protective System?

The previous definition of Protection System includes batteries, but leaves out chargers. The latest definition includes chargers, as well as dc systems that do not utilize batteries. This revision of PRC-005-4 is intended to capture these devices that were not included under the previous definition. The station direct current (dc) supply normally consists of two components: the battery charger and the station battery itself. There are also emerging technologies that provide a source of dc supply that does not include either a battery or charger.

Battery Charger - The battery charger is supplied by an available ac source. At a minimum, the battery charger must be sized to charge the battery (after discharge) and supply the constant dc load. In many cases, it may be sized also to provide sufficient dc current to handle the higher energy requirements of tripping breakers and switches when actuated by the protective relays in the Protection System.

Station Battery - Station batteries provide the dc power required for tripping and for supplying normal dc power to the station in the event of loss of the battery charger. There are several technologies of battery that require unique forms of maintenance as established in Table 1-4.

Emerging Technologies - Station dc supplies are currently being developed that use other energy storage technologies besides the station battery to prevent loss of the station dc supply when ac power is lost. Maintenance of these station dc supplies will require different kinds of tests and inspections. Table 1-4 presents maintenance activities and maximum allowable testing intervals for these new station dc supply technologies. However, because these technologies are relatively new, the maintenance activities for these station dc supplies may change over time.

What did the PSMT SDT mean by “continuity” of the dc supply?

The PSMT SDT recognizes that there are several technological advances in equipment and testing procedures that allow the owner to choose how to verify that a battery string is free of open circuits. The term “continuity” was introduced into the standard to allow the owner to choose how to verify continuity (no open circuits) of a battery set by various methods, and not to limit the owner to other conventional methods of showing continuity – lack of an open circuit. Continuity, as used in Table 1-4 of the standard, refers to verifying that there is a continuous current path from the positive terminal of the station battery set to the negative terminal (no open circuit). Without verifying continuity of a station battery, there is no way to determine that the station battery is available to supply dc power to the station. Whether it is caused from an open cell or a bad external connection, an open battery string will be an unavailable power source in the event of loss of the battery charger.

The current path through a station battery from its positive to its negative connection to the dc control circuits is composed of two types of elements. These path elements are the electrochemical path through each of its cells and all of the internal and external metallic connections and terminations of the batteries in the battery set. If there is loss of continuity (an open circuit) in any part of the electrochemical or metallic path, the battery set will not be available for service. In the event of the loss of the ac source or battery charger, the battery must be capable of supplying dc current, both for continuous dc loads and for tripping breakers and switches. Without continuity, the battery cannot perform this function.

At generating stations and large transmission stations where battery chargers are capable of handling the maximum current required by the Protection System, there are still problems that could potentially occur when the continuity through the connected battery is interrupted.

- Many battery chargers produce harmonics which can cause failure of dc power supplies in microprocessor-based protective relays and other electronic devices connected to station dc supply. In these cases, the substation battery serves as a filter for these harmonics. With the loss of continuity in the battery, the filter provided by the battery is no longer present.
- Loss of electrical continuity of the station battery will cause, in most battery chargers, regardless of the battery charger’s output current capability, a delayed response in full output current from the charger. Almost all chargers have an intentional one- to two-second delay to switch from a low substation dc load current to the maximum output of the charger. This delay would cause the opening of circuit breakers to be delayed, which could violate system performance standards.

Monitoring of the station dc supply voltage will not indicate that there is a problem with the dc current path through the battery, unless the battery charger is taken out of service. At that time,

a break in the continuity of the station battery current path will be revealed because there will be no voltage on the station dc circuitry. This particular test method, while proving battery continuity, may not be acceptable to all installations.

Although the standard prescribes what must be accomplished during the maintenance activity, it does not prescribe how the maintenance activity should be accomplished. There are several methods that can be used to verify the electrical continuity of the battery. These are not the only possible methods, simply a sampling of some methods:

- One method is to measure that there is current flowing through the battery itself by a simple clamp on milliamp-range ammeter. A battery is always either charging or discharging. Even when a battery is charged, there is still a measurable float charge current that can be detected to verify that there is continuity in the electrical path through the battery.
- A simple test for continuity is to remove the battery charger from service and verify that the battery provides voltage and current to the dc system. However, the behavior of the various dc-supplied equipment in the station should be considered before using this approach.
- Manufacturers of microprocessor-controlled battery chargers have developed methods for their equipment to periodically (or continuously) test for battery continuity. For example, one manufacturer periodically reduces the float voltage on the battery until current from the battery to the dc load can be measured to confirm continuity.
- Applying test current (as in some ohmic testing devices, or devices for locating dc grounds) will provide a current that when measured elsewhere in the string, will prove that the circuit is continuous.
- Internal ohmic measurements of the cells and units of lead-acid batteries (VRLA & VLA) can detect lack of continuity within the cells of a battery string; and when used in conjunction with resistance measurements of the battery's external connections, can prove continuity. Also some methods of taking internal ohmic measurements, by their very nature, can prove the continuity of a battery string without having to use the results of resistance measurements of the external connections.
- Specific gravity tests could infer continuity because without continuity there could be no charging occurring; and if there is no charging, then specific gravity will go down below acceptable levels over time.

No matter how the electrical continuity of a battery set is verified, it is a necessary maintenance activity that must be performed at the intervals prescribed by Table 1-4 to insure that the station dc supply has a path that can provide the required current to the Protection System at all times.

When should I check the station batteries to see if they have sufficient energy to perform as manufactured?

The answer to this question depends on the type of battery (valve-regulated lead-acid, vented lead-acid, or nickel-cadmium) and the maintenance activity chosen.

For example, if you have a valve-regulated lead-acid (VRLA) station battery, and you have chosen to evaluate the measured cell/unit internal ohmic values to the battery cell's baseline, you will have to perform verification at a maximum maintenance interval of no greater than

every six months. While this interval might seem to be quite short, keep in mind that the six-month interval is important for VRLA batteries; this interval provides an accumulation of data that better shows when a VRLA battery is incapable of performing as manufactured.

If, for a VRLA station battery, you choose to conduct a performance capacity test on the entire station battery as the maintenance activity, then you will have to perform verification at a maximum maintenance interval of no greater than every three calendar years.

How is a baseline established for cell/unit internal ohmic measurements?

Establishment of cell/unit internal ohmic baseline measurements should be completed when lead-acid batteries are newly installed. To ensure that the baseline ohmic cell/unit values are most indicative of the station battery's ability to perform as manufactured, they should be made at some point in time after the installation to allow the cell chemistry to stabilize after the initial freshening charge. An accepted industry practice for establishing baseline values is after six-months of installation, with the battery fully charged and in service. However, it is recommended that each owner, when establishing a baseline, should consult the battery manufacturer for specific instructions on establishing an ohmic baseline for their product, if available.

When internal ohmic measurements are taken, the same make/model test equipment should be used to establish the baseline and used for the future trending of the cells internal ohmic measurements because of variances in test equipment and the type of ohmic measurement used by different manufacturer's equipment. Keep in mind that one manufacturer's "Conductance" test equipment does not produce similar results as another manufacturer's "Conductance" test equipment, even though both manufacturers have produced "Ohmic" test equipment. Therefore, for meaningful results to an established baseline, the same make/model of instrument should be used.

For all new installations of valve-regulated lead-acid (VRLA) batteries and vented lead-acid (VLA) batteries, where trending of the cells internal ohmic measurements to a baseline are to be used to determine the ability of the station battery to perform as manufactured, the establishment of the baseline, as described above, should be followed at the time of installation to insure the most accurate trending of the cell/unit. However, often for older VRLA batteries, the owners of the station batteries have not established a baseline at installation. Also for owners of VLA batteries who want to establish a maintenance activity which requires trending of measured ohmic values to a baseline, there was typically no baseline established at installation of the station battery to trend to.

To resolve the problem of the unavailability of baseline internal ohmic measurements for the individual cell/unit of a station battery, many manufacturers of internal ohmic measurement devices have established libraries of baseline values for VRLA and VLA batteries using their testing device. Also, several of the battery manufacturers have libraries of baselines for their products that can be used to trend to. However, it is important that when using battery manufacturer-supplied data that it is verified that the baseline readings to be used were taken with the same ohmic testing device that will be used for future measurements (for example "Conductance Readings" from one manufacturer's test equipment do not correlate to "Impedance Readings" from a different manufacturer's test equipment). Although many manufacturers may have provided baseline values, which will allow trending of the internal ohmic measurements over the remaining life of a station battery, these baselines are not the actual cell/unit measurements for

the battery being trended. It is important to have a baseline tailored to the station battery to more accurately use the tool of ohmic measurement trending. That more customized baseline can only be created by following the establishment of a baseline for each cell/unit at the time of installation of the station battery.

Why determine the State of Charge?

Even though there is no present requirement to check the state of charge of a battery, it can be a very useful tool in determining the overall condition of a battery system. The following discussions are offered as a general reference.

When a battery is fully charged, the battery is available to deliver its existing capacity. As a battery is discharged, its ability to deliver its maximum available capacity is diminished. It is necessary to determine if the state of charge has dropped to an unacceptable level.

What is State of Charge and how can it be determined in a station battery?

The state of charge of a battery refers to the ratio of residual capacity at a given instant to the maximum capacity available from the battery. When a battery is fully charged, the battery is available to deliver its existing capacity. As a battery is discharged, its ability to deliver its maximum available capacity is diminished. Knowing the amount of energy left in a battery compared with the energy it had when it was fully charged gives the user an indication of how much longer a battery will continue to perform before it needs recharging.

For vented lead-acid (VLA) batteries which use accessible liquid electrolyte, a hydrometer can be used to test the specific gravity of each cell as a measure of its state of charge. The hydrometer depends on measuring changes in the weight of the active chemicals. As the battery discharges, the active electrolyte, sulfuric acid, is consumed and the concentration of the sulfuric acid in water is reduced. This, in turn, reduces the specific gravity of the solution in direct proportion to the state of charge. The actual specific gravity of the electrolyte can, therefore, be used as an indication of the state of charge of the battery. Hydrometer readings may not tell the whole story, as it takes a while for the acid to get mixed up in the cells of a VLA battery. If measured right after charging, you might see high specific gravity readings at the top of the cell, even though it is much less at the bottom. Conversely, if taken shortly after adding water to the cell, the specific gravity readings near the top of the cell will be lower than those at the bottom.

Nickel-cadmium batteries, where the specific gravity of the electrolyte does not change during battery charge and discharge, and valve-regulated lead-acid (VRLA) batteries, where the electrolyte is not accessible, cannot have their state of charge determined by specific gravity readings. For these two types of batteries, and for VLA batteries also, where another method besides taking hydrometer readings is desired, the state of charge may be determined by taking voltage and current readings at the battery terminals. The methods employed to obtain accurate readings vary for the different battery types. Manufacturers' information and IEEE guidelines can be consulted for specifics; (see IEEE 1106 Annex B for Nickel Cadmium batteries, IEEE 1188 Annex A for VRLA batteries and IEEE 450 for VLA batteries).

Why determine the Connection Resistance?

High connection resistance can cause abnormal voltage drop or excessive heating during discharge of a station battery. During periods of a high rate of discharge of the station battery, a very high resistance can cause severe damage. The maintenance requirement to verify battery terminal connection resistance in Table 1-4 is established to verify that the integrity of all battery electrical connections is acceptable. This verification includes cell-to-cell (intercell) and external

circuit terminations. Your method of checking for acceptable values of intercell and terminal connection resistance could be by individual readings, or a combination of the two. There are test methods presently that can read post termination resistances and resistance values between external posts. There are also test methods presently available that take a combination reading of the post termination connection resistance plus the intercell resistance value plus the post termination connection resistance value. Either of the two methods, or any other method, that can show if the adequacy of connections at the battery posts is acceptable.

Adequacy of the electrical terminations can be determined by comparing resistance measurements for all connections taken at the time of station battery's installation to the same resistance measurements taken at the maintenance interval chosen, not to exceed the maximum maintenance interval of Table 1-4. Trending of the interval measurements to the baseline measurements will identify any degradation in the battery connections. When the connection resistance values exceed the acceptance criteria for the connection, the connection is typically disassembled, cleaned, reassembled and measurements taken to verify that the measurements are adequate when compared to the baseline readings.

What conditions should be inspected for visible battery cells?

The maintenance requirement to inspect the cell condition of all station battery cells where the cells are visible is a maintenance requirement of Table 1-4. Station batteries are different from any other component in the Protection Station because they are a perishable product due to the electrochemical process which is used to produce dc electrical current and voltage. This inspection is a detailed visual inspection of the cells for abnormalities that occur in the aging process of the cell. In VLA battery visual inspections, some of the things that the inspector is typically looking for on the plates are signs of sulfation of the plates, abnormal colors (which are an indicator of sulfation or possible copper contamination) and abnormal conditions such as cracked grids. The visual inspection could look for symptoms of hydration that would indicate that the battery has been left in a completely discharged state for a prolonged period. Besides looking at the plates for signs of aging, all internal connections, such as the bus bar connection to each plate, and the connections to all posts of the battery need to be visually inspected for abnormalities. In a complete visual inspection for the condition of the cell the cell plates, separators and sediment space of each cell must be looked at for signs of deterioration. An inspection of the station battery's cell condition also includes looking at all terminal posts and cell-to-cell electric connections to ensure they are corrosion free. The case of the battery containing the cell, or cells, must be inspected for cracks and electrolyte leaks through cracks and the post seals.

This maintenance activity cannot be extended beyond the maximum maintenance interval of Table 1-4 by a Performance-Based Maintenance Program (PBM) because of the electrochemical aging process of the station battery, nor can there be any monitoring associated with it because there must be a visual inspection involved in the activity. A remote visual inspection could possibly be done, but its interval must be no greater than the maximum maintenance interval of Table 1-4.

Why is it necessary to verify the battery string can perform as manufactured? I only care that the battery can trip the breaker, which means that the battery can perform as designed. I oversize my batteries so that even if the battery cannot perform as manufactured, it can still trip my breakers.

The fundamental answer to this question revolves around the concept of battery performance “as designed” vs. battery performance “as manufactured.” The purpose of the various sections of Table 1-4 of this standard is to establish requirements for the Protection System owner to maintain the batteries, to ensure they will operate the equipment when there is an incident that requires dc power, and ensure the batteries will continue to provide adequate service until at least the next maintenance interval. To meet these goals, the correct battery has to be properly selected to meet the design parameters, and the battery has to deliver the power it was manufactured to provide.

When testing batteries, it may be difficult to determine the original design (i.e., load profile) of the dc system. This standard is not intended as a design document, and requirements relating to design are, therefore, not included.

Where the dc load profile is known, the best way to determine if the system will operate as designed is to conduct a service test on the battery. However, a service test alone might not fully determine if the battery is healthy. A battery with 50% capacity may be able to pass a service test, but the battery would be in a serious state of deterioration and could fail at some point in the near future.

To ensure that the battery will meet the required load profile and continue to meet the load profile until the next maintenance interval, the installed battery must be sized correctly (i.e., a correct design), and it must be in a good state of health. Since the design of the dc system is not within the scope of the standard, the only consistent and reliable method to ensure that the battery is in a good state of health is to confirm that it can perform as manufactured. If the battery can perform as manufactured and it has been designed properly, the system should operate properly until the next maintenance interval.

How do I verify the battery string can perform as manufactured?

Optimally, actual battery performance should be verified against the manufacturer’s rating curves. The best practice for evaluating battery performance is via a performance test. However, due to both logistical and system reliability concerns, some Protection System owners prefer other methods to determine if a battery can perform as manufactured. There are several battery parameters that can be evaluated to determine if a battery can perform as manufactured. Ohmic measurements and float current are two examples of parameters that have been reported to assist in determining if a battery string can perform as manufactured.

The evaluation of battery parameters in determining battery health is a complex issue, and is not an exact science. This standard gives the user an opportunity to utilize other measured parameters to determine if the battery can perform as manufactured. It is the responsibility of the Protection System owner, however, to maintain a documented process that demonstrates the chosen parameter(s) and associated methodology used to determine if the battery string can perform as manufactured.

Whatever parameters are used to evaluate the battery (ohmic measurements, float current, float voltages, temperature, specific gravity, performance test, or combination thereof), the goal is to determine the value of the measurement (or the percentage change) at which the battery fails to perform as manufactured, or the point where the battery is deteriorating so rapidly that it will not perform as manufactured before the next maintenance interval.

This necessitates the need for establishing and documenting a baseline. A baseline may be required of every individual cell, a particular battery installation, or a specific make, model, or size of a cell. Given a consistent cell manufacturing process, it may be possible to establish a baseline number for the cell (make/model/type) and, therefore, a subsequent baseline for every installation would not be necessary. However, future installations of the same battery types should be spot-checked to ensure that your baseline remains applicable.

Consistent testing methods by trained personnel are essential. Moreover, it is essential that these technicians utilize the same make/model of ohmic test equipment each time readings are taken in order to establish a meaningful and accurate trend line against the established baseline. The type of probe and its location (post, connector, etc.) for the reading need to be the same for each subsequent test. The room temperature should be recorded with the readings for each test as well. Care should be taken to consider any factors that might lead a trending program to become invalid.

Float current along with other measurable parameters can be used in lieu of or in concert with ohmic measurement testing to measure the ability of a battery to perform as manufactured. The key to using any of these measurement parameters is to establish a baseline and the point where the reading indicates that the battery will not perform as manufactured.

The establishment of a baseline may be different for various types of cells and for different types of installations. In some cases, it may be possible to obtain a baseline number from the battery manufacturer, although it is much more likely that the baseline will have to be established after the installation is complete. To some degree, the battery may still be “forming” after installation; consequently, determining a stable baseline may not be possible until several months after the battery has been in service.

The most important part of this process is to determine the point where the ohmic reading (or other measured parameter(s)) indicates that the battery cannot perform as manufactured. That point could be an absolute number, an absolute change, or a percentage change of an established baseline.

Since there are no universally-accepted repositories of this information, the Protection System owner will have to determine the value/percentage where the battery cannot perform as manufactured (heretofore referred to as a failed cell). This is the most difficult and important part of the entire process.

To determine the point where the battery fails to perform as manufactured, it is helpful to have a history of a battery type, if the data includes the parameter(s) used to evaluate the battery's ability to perform as manufactured against the actual demonstrated performance/capacity of a battery/cell.

For example, when an ohmic reading has been recorded that the user suspects is indicating a failed cell, a performance test of that cell (or string) should be conducted in order to prove/quantify that the cell has failed. Through this process, the user needs to determine the ohmic value at which the performance of the cell has dropped below 80% of the manufactured, rated performance. It is likely that there may be a variation in ohmic readings that indicates a failed cell (possibly significant). It is prudent to use the most conservative values to determine the point at which the cell should be marked for replacement. Periodically, the user should

demonstrate that an “adequate” ohmic reading equates to an adequate battery performance (>80% of capacity).

Similarly, acceptance criteria for "good" and "failed" cells should be established for other parameters such as float current, specific gravity, etc., if used to determine the ability of a battery to function as designed.

What happens if I change the make/model of ohmic test equipment after the battery has been installed for a period of time?

If a user decides to switch testers, either voluntarily or because the equipment is not supported/sold any longer, the user may have to establish a new base line and new parameters that indicate when the battery no longer performs as manufactured. The user always has a choice to perform a capacity test in lieu of establishing new parameters.

What are some of the differences between lead-acid and nickel-cadmium batteries?

There is a marked difference in the aging process of lead acid and nickel-cadmium station batteries. The difference in the aging process of these two types of batteries is chiefly due to the electrochemical process of the battery type. Aging and eventual failure of lead acid batteries is due to expansion and corrosion of the positive grid structure, loss of positive plate active material, and loss of capacity caused by physical changes in the active material of the positive plates. In contrast, the primary failure of nickel-cadmium batteries is due to the gradual linear aging of the active materials in the plates. The electrolyte of a nickel-cadmium battery only facilitates the chemical reaction (it functions only to transfer ions between the positive and negative plates), but is not chemically altered during the process like the electrolyte of a lead acid battery. A lead acid battery experiences continued corrosion of the positive plate and grid structure throughout its operational life while a nickel-cadmium battery does not.

Changes to the properties of a lead acid battery when periodically measured and trended to a baseline, can indicate aging of the grid structure, positive plate deterioration, or changes in the active materials in the plate.

Because of the clear differences in the aging process of lead acid and nickel-cadmium batteries, there are no significantly measurable properties of the nickel-cadmium battery that can be measured at a periodic interval and trended to determine aging. For this reason, Table 1-4(c) (Protection System Station dc supply Using nickel-cadmium [NiCad] Batteries) only specifies one minimum maintenance activity and associated maximum maintenance interval necessary to verify that the station battery can perform as manufactured by evaluating cell/unit measurements indicative of battery performance against the station battery baseline. This maintenance activity is to conduct a performance or modified performance capacity test of the entire battery bank.

Why in Table 1-4 of PRC-005-4 is there a maintenance activity to inspect the structural integrity of the battery rack?

The purpose of this inspection is to verify that the battery rack is correctly installed and has no deterioration that could weaken its structural integrity.

Because the battery rack is specifically manufactured for the battery that is mounted on it, weakening of its structural members by rust or corrosion can physically jeopardize the battery.

What is required to comply with the “Unintentional dc Grounds” requirement?

In most cases, the first ground that appears on a battery is not a problem. It is the unintentional ground that appears on the opposite pole that becomes problematic. Even then many systems are designed to operate favorably under some unintentional dc ground situations. It is up to the owner of the Protection System to determine if corrective actions are needed on detected unintentional dc grounds. The standard merely requires that a check be made for the existence of unintentional dc grounds. Obviously, a “check-off” of some sort will have to be devised by the inspecting entity to document that a check is routinely done for unintentional dc grounds because of the possible consequences to the Protection System.

Where the standard refers to “all cells,” is it sufficient to have a documentation method that refers to “all cells,” or do we need to have separate documentation for every cell? For example, do I need 60 individual documented check-offs for good electrolyte level, or would a single check-off per bank be sufficient?

A single check-off per battery bank is sufficient for documentation, as long as the single check-off attests to checking all cells/units.

Does this standard refer to Station batteries or all batteries; for example, Communications Site Batteries?

This standard refers to Station Batteries. The drafting team does not believe that the scope of this standard refers to communications sites. The batteries covered under PRC-005-4 are the batteries that supply the trip current to the trip coils of the interrupting devices that are a part of the Protection System. The SDT believes that a loss of power to the communications systems at a remote site would cause the communications systems associated with protective relays to alarm at the substation. At this point, the corrective actions can be initiated.

What are cell/unit internal ohmic measurements?

With the introduction of Valve-Regulated Lead-Acid (VRLA) batteries to station dc supplies in the 1980’s several of the standard maintenance tools that are used on Vented Lead-Acid (VLA) batteries were unable to be used on this new type of lead-acid battery to determine its state of health. The only tools that were available to give indication of the health of these new VRLA batteries were voltage readings of the total battery voltage, the voltage of the individual cells and periodic discharge tests.

In the search for a tool for determining the health of a VRLA battery several manufacturers studied the electrical model of a lead acid battery’s current path through its cell. The overall battery current path consists of resistance and inductive and capacitive reactance. The inductive reactance in the current path through the battery is so minuscule when compared to the huge capacitive reactance of the cells that it is often ignored in most circuit models of the battery cell. Taking the basic model of a battery cell manufacturers of battery test equipment have developed and marketed testing devices to take measurements of the current path to detect degradation in the internal path through the cell.

In the battery industry, these various types of measurements are referred to as ohmic measurements. Terms used by the industry to describe ohmic measurements are ac conductance, ac impedance, and dc resistance. They are defined by the test equipment providers and IEEE and refer to the method of taking ohmic measurements of a lead acid battery. For example, in one manufacturer’s ac conductance equipment measurements are taken by applying a voltage of a known frequency and amplitude across a cell or battery unit and observing the ac

current flow it produces in response to the voltage. A manufacturer of an ac impedance meter measures ac current of a known frequency and amplitude that is passed through the whole battery string and determines the impedances of each cell or unit by measuring the resultant ac voltage drop across them. On the other hand, dc resistance of a cell is measured by a third manufacturer's equipment by applying a dc load across the cell or unit and measuring the step change in both the voltage and current to calculate the internal dc resistance of the cell or unit.

It is important to note that because of the rapid development of the market for ohmic measurement devices, there were no standards developed or used to mandate the test signals used in making ohmic measurements. Manufacturers using proprietary methods and applying different frequencies and magnitudes for their signals have developed a diversity of measurement devices. This diversity in test signals coupled with the three different types of ohmic measurements techniques (impedance conductance and resistance) make it impossible to always get the same ohmic measurement for a cell with different ohmic measurement devices. However, IEEE has recognized the great value for choosing one device for ohmic measurement, no matter who makes it or the method to calculate the ohmic measurement. The only caution given by IEEE and the battery manufacturers is that when trending the cells of a lead acid station battery consistent ohmic measurement devices should be used to establish the baseline measurement and to trend the battery set for its entire life.

For VRLA batteries both IEEE Standard 1188 (Maintenance, Testing and Replacement of VRLA Batteries) and IEEE Standard 1187 (Installation Design and Installation of VRLA Batteries) recognize the importance of the maintenance activity of establishing a baseline for "cell/unit internal ohmic measurements (impedance, conductance and resistance)" and trending them at frequent intervals over the life of the battery. There are extensive discussions about the need for taking these measurements in these standards. IEEE Standard 1188 requires taking internal ohmic values as described in Annex C4 during regular inspections of the station battery. For VRLA batteries IEEE Standard 1188 in talking about the necessity of establishing a baseline and trending it over time says, "...depending on the degree of change a performance test, cell replacement or other corrective action may be necessary..." (IEEE std 1188-2005, C.4 page 18).

For VLA batteries IEEE Standard 484 (Installation of VLA batteries) gives several guidelines about establishing baseline measurements on newly installed lead acid stationary batteries. The standard also discusses the need to look for significant changes in the ohmic measurements, the caution that measurement data will differ with each type of model of instrument used, and lists a number of factors that affect ohmic measurements.

At the beginning of the 21st century, EPRI conducted a series of extensive studies to determine the relationship of internal ohmic measurements to the capacity of a lead acid battery cell. The studies indicated that internal ohmic measurements were in fact a good indicator of a lead acid battery cell's capacity, but because users often were only interested in the total station battery capacity and the technology does not precisely predict overall battery capacity, if a user only needs "an accurate measure of the overall battery capacity," they should "perform a battery capacity test."

Prior to the EPRI studies some large and small companies which owned and maintained station dc supplies in NERC Protection Systems developed maintenance programs where trending of ohmic measurements of cells/units of the station's battery became the maintenance activity for determining if the station battery could perform as manufactured. By evaluation of the trending

of the ohmic measurements over time, the owner could track the performance of the individual components of the station battery and determine if a total station battery or components of it required capacity testing, removal, replacement or in many instances replacement of the entire station battery. By taking this condition based approach these owners have eliminated having to perform capacity testing at prescribed intervals to determine if a battery needs to be replaced and are still able to effectively determine if a station battery can perform as manufactured.

My VRLA batteries have multiple-cells within an individual battery jar (or unit); how am I expected to comply with the cell-to-cell ohmic measurement requirements on these units that I cannot get to?

Measurement of cell/unit (not all batteries allow access to “individual cells” some “units” or jars may have multiple cells within a jar) internal ohmic values of all types of lead acid batteries where the cells of the battery are not visible is a station dc supply maintenance activity in Table 1-4. In cases where individual cells in a multi-cell unit are inaccessible, an ohmic measurement of the entire unit may be made.

I have a concern about my batteries being used to support additional auxiliary loads beyond my protection control systems in a generation station. Is ohmic measurement testing sufficient for my needs?

While this standard is focused on addressing requirements for Protection Systems, if batteries are used to service other load requirements beyond that of Protection Systems (e.g. pumps, valves, inverter loads), the functional entity may consider additional testing to confirm that the capacity of the battery is sufficient to support all loads.

Why verify voltage?

There are two required maintenance activities associated with verification of dc voltages in Table 1-4. These two required activities are to verify station dc supply voltage and float voltage of the battery charger, and have different maximum maintenance intervals. Both of these voltage verification requirements relate directly to the battery charger maintenance.

The verification of the dc supply voltage is simply an observation of battery voltage to prove that the charger has not been lost or is not malfunctioning; a reading taken from the battery charger panel meter or even SCADA values of the dc voltage could be some of the ways that one could satisfy the requirements. Low battery voltage below float voltage indicates that the battery may be on discharge and, if not corrected, the station battery could discharge down to some extremely low value that will not operate the Protection System. High voltage, close to or above the maximum allowable dc voltage for equipment connected to the station dc supply indicates the battery charger may be malfunctioning by producing high dc voltage levels on the Protection System. If corrective actions are not taken to bring the high voltage down, the dc power supplies and other electronic devices connected to the station dc supply may be damaged. The maintenance activity of verifying the float voltage of the battery charger is not to prove that a charger is lost or producing high voltages on the station dc supply, but rather to prove that the charger is properly floating the battery within the proper voltage limits. As above, there are many ways that this requirement can be met.

Why check for the electrolyte level?

In vented lead-acid (VLA) and nickel-cadmium (NiCad) batteries the visible electrolyte level must be checked as one of the required maintenance activities that must be performed at an interval that is equal to or less than the maximum maintenance interval of Table 1-4. Because the electrolyte level in valve-regulated lead-acid (VRLA) batteries cannot be observed, there is no maintenance activity listed in Table 1-4 of the standard for checking the electrolyte level. Low electrolyte level of any cell of a VLA or NiCad station battery is a condition requiring correction. Typically, the electrolyte level should be returned to an acceptable level for both types of batteries (VLA and NiCad) by adding distilled or other approved-quality water to the cell.

Often people confuse the interval for watering all cells required due to evaporation of the electrolyte in the station battery cells with the maximum maintenance interval required to check the electrolyte level. In many of the modern station batteries, the jar containing the electrolyte is so large with the band between the high and low electrolyte level so wide that normal evaporation which would require periodic watering of all cells takes several years to occur. However, because loss of electrolyte due to cracks in the jar, overcharging of the station battery, or other unforeseen events can cause rapid loss of electrolyte; the shorter maximum maintenance intervals for checking the electrolyte level are required. A low level of electrolyte in a VLA battery cell which exposes the tops of the plates can cause the exposed portion of the plates to accelerated sulfation resulting in loss of cell capacity. Also, in a VLA battery where the electrolyte level goes below the end of the cell withdrawal tube or filling funnel, gasses can exit the cell by the tube instead of the flame arrester and present an explosion hazard.

What are the parameters that can be evaluated in Tables 1-4(a) and 1-4(b)?

The most common parameter that is periodically trended and evaluated by industry today to verify that the station battery can perform as manufactured is internal ohmic cell/unit measurements.

In the mid-1990s, several large and small utilities began developing maintenance and testing programs for Protection System station batteries using a condition based maintenance approach of trending internal ohmic measurements to each station battery cell's baseline value. Battery owners use the data collected from this maintenance activity to determine (1) when a station battery requires a capacity test (instead of performing a capacity test on a predetermined, prescribed interval), (2) when an individual cell or battery unit should be replaced, or (3) based on the analysis of the trended data, if the station battery should be replaced without performing a capacity test.

Other examples of measurable parameters that can be periodically trended and evaluated for lead acid batteries are cell voltage, float current, connection resistance. However, periodically trending and evaluating cell/unit Ohmic measurements are the most common battery/cell parameters that are evaluated by industry to verify a lead acid battery string can perform as manufactured.

Why does it appear that there are two maintenance activities in Table 1-4(b) (for VRLA batteries) that appear to be the same activity and have the same maximum maintenance interval?

There are two different and distinct reasons for doing almost the same maintenance activity at the same interval for valve-regulated lead-acid (VRLA) batteries. The first similar activity for VRLA batteries (Table 1-4(b)) that has the same maximum maintenance interval is to "measure battery cell/unit internal ohmic values." Part of the reason for this activity is because the visual inspection of the cell condition is unavailable for VRLA batteries. Besides the requirement to

measure the internal ohmic measurements of VRLA batteries to determine the internal health of the cell, the maximum maintenance interval for this activity is significantly shorter than the interval for vented lead-acid (VLA) due to some unique failure modes for VRLA batteries. Some of the potential problems that VRLA batteries are susceptible to that do not affect VLA batteries are thermal runaway, cell dry-out, and cell reversal when one cell has a very low capacity.

The other similar activity listed in Table 1-4(b) is “...verify that the station battery can perform as manufactured by evaluating the measured cell/unit measurements indicative of battery performance (e.g. internal ohmic values) against the station battery baseline.” This activity allows an owner the option to choose between this activity with its much shorter maximum maintenance interval or the longer maximum maintenance interval for the maintenance activity to “Verify that the station battery can perform as manufactured by conducting a performance or modified performance capacity test of the entire battery bank.”

For VRLA batteries, there are two drivers for internal ohmic readings. The first driver is for a means to trend battery life. Trending against the baseline of VRLA cells in a battery string is essential to determine the approximate state of health of the battery. Ohmic measurement testing may be used as the mechanism for measuring the battery cells. If all the cells in the string exhibit a consistent trend line and that trend line has not risen above a specific deviation (e.g. 30%) over baseline for impedance tests or below baseline for conductance tests, then a judgment can be made that the battery is still in a reasonably good state of health and able to ‘perform as manufactured.’ It is essential that the specific deviation mentioned above is based on data (test or otherwise) that correlates the ohmic readings for a specific battery/tester combination to the health of the battery. This is the intent of the “perform as manufactured six-month test” at Row 4 on Table 1-4b.

The second big driver is VRLA batteries tendency for thermal runaway. This is the intent of the “thermal runaway test” at Row 2 on Table 1-4b. In order to detect a cell in thermal runaway, you need not necessarily have a formal trending program. When a single cell/unit changes significantly or significantly varies from the other cells (e.g. a doubling of resistance/impedance or a 50% decrease in conductance), there is a high probability that the cell/unit/string needs to be replaced as soon as possible. In other words, if the battery is 10 years old and all the cells have approached a significant change in ohmic values over baseline, then you have a battery which is approaching end of life. You need to get ready to buy a new battery, but you do not have to worry about an impending catastrophic failure. On the other hand, if the battery is five years old and you have one cell that has a markedly different ohmic reading than all the other cells, then you need to be worried that this cell is susceptible to thermal runaway. If the float (charging) current has risen significantly and the ohmic measurement has increased/decreased as described above then concern of catastrophic failure should trigger attention for corrective action.

If an entity elects to use a capacity test rather than a cell ohmic value trending program, this does not eliminate the need to be concerned about thermal runaway – the entity still needs to do the six-month readings and look for cells which are outliers in the string but they need not trend results against the factory/as new baseline. Some entities will not mind the extra administrative burden of having the ongoing trending program against baseline - others would rather just do

the capacity test and not have to trend the data against baseline. Nonetheless, all entities must look for ohmic outliers on a six-month basis.

It is possible to accomplish both tasks listed (trend testing for capability and testing for thermal runaway candidates) with the very same ohmic test. It becomes an analysis exercise of watching the trend from baselines and watching for the oblique cell measurement.

In table 1-4(f) (Exclusions for Protection System Station dc Supply Monitoring Devices and Systems), must all component attributes listed in the table be met before an exclusion can be granted for a maintenance activity?

Table 1-4(f) was created by the drafting team to allow Protection System dc supply owners to obtain exclusions from periodic maintenance activities by using monitoring devices. The basis of the exclusions granted in the table is that the monitoring devices must incorporate the monitoring capability of microprocessor based components which perform continuous self-monitoring. For failure of the microprocessor device used in dc supply monitoring, the self-checking routine in the microprocessor must generate an alarm which will be reported within 24 hours of device failure to a location where corrective action can be initiated.

Table 1-4(f) lists 8 component attributes along with a specific periodic maintenance activity associated with each of the 8 attributes listed. If an owner of a station dc supply wants to be excluded from periodically performing one of the 8 maintenance activities listed in table 1-4(f), the owner must have evidence that the monitoring and alarming component attributes associated with the excluded maintenance activity are met by the self-checking microprocessor based device with the specific component attribute listed in the table 1-4(f).

For example if an owner of a VLA station battery does not want to “verify station dc supply voltage” every “4 calendar months” (see table 1-4(a)), the owner can install a monitoring and alarming device “with high and low voltage monitoring and alarming of the battery charger voltage to detect charger overvoltage and charger failure” and “no periodic verification of station dc supply voltage is required” (see table 1-4(f) first row). However, if for the same Protection System discussed above, the owner does not install “electrolyte level monitoring and alarming in every cell” and “unintentional dc ground monitoring and alarming” (see second and third rows of table 1-4(f)), the owner will have to “inspect electrolyte level and for unintentional grounds” every “4 calendar months” (see table 1-4(a)).

15.5 Associated communications equipment (Table 1-2)

The equipment used for tripping in a communications-assisted trip scheme is a vital piece of the trip circuit. Remote action causing a local trip can be thought of as another parallel trip path to the trip coil that must be tested. Besides the trip output and wiring to the trip coil(s), there is also a communications medium that must be maintained. Newer technologies now exist that achieve communications-assisted tripping without the conventional wiring practices of older technology. For example, older technologies may have included Frequency Shift Key methods. This technology requires that guard and trip levels be maintained. The actual tripping path(s) to the trip coil(s) may be tested as a parallel trip path within the dc control circuitry tests. Emerging technologies transfer digital information over a variety of carrier mediums that are then

interpreted locally as trip signals. The requirements apply to the communicated signal needed for the proper operation of the protective relay trip logic or scheme. Therefore, this standard is applied to equipment used to convey both trip signals (permissive or direct) and block signals.

It was the intent of this standard to require that a test be performed on any communications-assisted trip scheme, regardless of the vintage of technology. The essential element is that the tripping (or blocking) occurs locally when the remote action has been asserted; or that the tripping (or blocking) occurs remotely when the local action is asserted. Note that the required testing can still be done within the concept of testing by overlapping segments. Associated communications equipment can be (but is not limited to) testing at other times and different frequencies as the protective relays, the individual trip paths and the affected circuit interrupting devices.

Some newer installations utilize digital signals over fiber-optics from the protective relays in the control house to the circuit interrupting device in the yard. This method of tripping the circuit breaker, even though it might be considered communications, must be maintained per the dc control circuitry maintenance requirements.

15.5.1 Frequently Asked Questions:

What are some examples of mechanisms to check communications equipment functioning?

For unmonitored Protection Systems, various types of communications systems will have different facilities for on-site integrity checking to be performed at least every four months during a substation visit. Some examples are, but not limited to:

- On-off power-line carrier systems can be checked by performing a manual carrier keying test between the line terminals, or carrier check-back test from one terminal.
- Systems which use frequency-shift communications with a continuous guard signal (over a telephone circuit, analog microwave system, etc.) can be checked by observing for a loss-of-guard indication or alarm. For frequency-shift power-line carrier systems, the guard signal level meter can also be checked.
- Hard-wired pilot wire line Protection Systems typically have pilot-wire monitoring relays that give an alarm indication for a pilot wire ground or open pilot wire circuit loop.
- Digital communications systems typically have a data reception indicator or data error indicator (based on loss of signal, bit error rate, or frame error checking).

For monitored Protection Systems, various types of communications systems will have different facilities for monitoring the presence of the communications channel, and activating alarms that can be monitored remotely. Some examples are, but not limited to:

- On-off power-line carrier systems can be shown to be operational by automated periodic power-line carrier check-back tests with remote alarming of failures.
- Systems which use a frequency-shift communications with a continuous guard signal (over a telephone circuit, analog microwave system, etc.) can be remotely monitored with a loss-of-guard alarm or low signal level alarm.
- Hard-wired pilot wire line Protection Systems can be monitored by remote alarming of pilot-wire monitoring relays.
- Digital communications systems can activate remotely monitored alarms for data reception loss or data error indications.
- Systems can be queried for the data error rates.

For the highest degree of monitoring of Protection Systems, the communications system must monitor all aspects of the performance and quality of the channel that show it meets the design performance criteria, including monitoring of the channel interface to protective relays.

- In many communications systems signal quality measurements, including signal-to-noise ratio, received signal level, reflected transmitter power or standing wave ratio, propagation delay, and data error rates are compared to alarm limits. These alarms are connected for remote monitoring.
- Alarms for inadequate performance are remotely monitored at all times, and the alarm communications system to the remote monitoring site must itself be continuously monitored to assure that the actual alarm status at the communications equipment location is continuously being reflected at the remote monitoring site.

What is needed for the four-month inspection of communications-assisted trip scheme equipment?

The four-month inspection applies to unmonitored equipment. An example of compliance with this requirement might be, but is not limited to:

With each site visit, check that the equipment is free from alarms; check any metered signal levels, and that power is still applied. While this might be explicit for a particular type of equipment (i.e., FSK equipment), the concept should be that the entity verify that the communications equipment that is used in a Protection System is operable through a cursory inspection and site visit. This site visit can be eliminated on this particular example if the FSK equipment had a monitored alarm on Loss of Guard. Blocking carrier systems with auto checkbacks will present an alarm when the channel fails allowing a visual indication. With no auto checkback, the channel integrity will need to be verified by a manual checkback or a two ended signal check. This check could also be eliminated by bring the auto checkback failure alarm to the monitored central location.

Does a fiber optic I/O scheme used for breaker tripping or control within a station, for example - transmitting a trip signal or control logic between the control house and the breaker control cabinet, constitute a communications system?

This equipment is presently classified as being part of the Protection System control circuitry and tested per the portions of Table 1 applicable to “Protection System Control Circuitry”, rather than those portions of the table applicable to communications equipment.

What is meant by “Channel” and “Communications Systems” in Table 1-2?

The transmission of logic or data from a relay in one station to a relay in another station for use in a pilot relay scheme will require a communications system of some sort. Typical relay communications systems use fiber optics, leased audio channels, power line carrier, and microwave. The overall communications system includes the channel and the associated communications equipment.

This standard refers to the “channel” as the medium between the transmitters and receivers in the relay panels such as a leased audio or digital communications circuit, power line and power line carrier auxiliary equipment, and fiber. The dividing line between the channel and the associated communications equipment is different for each type of media.

Examples of the Channel:

- Power Line Carrier (PLC) - The PLC channel starts and ends at the PLC transmitter and receiver output unless there is an internal hybrid. The channel includes the external hybrids, tuners, wave traps and the power line itself.
- Microwave –The channel includes the microwave multiplexers, radios, antennae and associated auxiliary equipment. The audio tone and digital transmitters and receivers in the relay panel are the associated communications equipment.
- Digital/Audio Circuit – The channel includes the equipment within and between the substations. The associated communications equipment includes the relay panel transmitters and receivers and the interface equipment in the relays.

-
- Fiber Optic – The channel starts at the fiber optic connectors on the fiber distribution panel at the local station and goes to the fiber optic distribution panel at the remote substation. The jumpers that connect the relaying equipment to the fiber distribution panel and any optical-electrical signal format converters are the associated communications equipment

Figure 1-2, A-1 and A-2 at the end of this document show good examples of the communications channel and the associated communications equipment.

In Table 1-2, the Maintenance Activities section of the Protection System Communications Equipment and Channels refers to the quality of the channel meeting “performance criteria.” What is meant by performance criteria?

Protection System communications channels must have a means of determining if the channel and communications equipment is operating normally. If the channel is not operating normally, an alarm will be indicated. For unmonitored systems, this alarm will probably be on the panel. For monitored systems, the alarm will be transmitted to a remote location.

Each entity will have established a nominal performance level for each Protection System communications channel that is consistent with proper functioning of the Protection System. If that level of nominal performance is not being met, the system will go into alarm. Following are some examples of Protection System communications channel performance measuring:

- For direct transfer trip using a frequency shift power line carrier channel, a guard level monitor is part of the equipment. A normal receive level is established when the system is calibrated and if the signal level drops below an established level, the system will indicate an alarm.
- An on-off blocking signal over power line carrier is used for directional comparison blocking schemes on transmission lines. During a Fault, block logic is sent to the remote relays by turning on a local transmitter and sending the signal over the power line to a receiver at the remote end. This signal is normally off so continuous levels cannot be checked. These schemes use check-back testing to determine channel performance. A predetermined signal sequence is sent to the remote end and the remote end decodes this signal and sends a signal sequence back. If the sending end receives the correct information from the remote terminal, the test passes and no alarm is indicated. Full power and reduced power tests are typically run. Power levels for these tests are determined at the time of calibration.
- Pilot wire relay systems use a hardwire communications circuit to communicate between the local and remote ends of the protective zone. This circuit is monitored by circulating a dc current between the relay systems. A typical level may be 1 mA. If the level drops below the setting of the alarm monitor, the system will indicate an alarm.
- Modern digital relay systems use data communications to transmit relay information to the remote end relays. An example of this is a line current differential scheme commonly used on transmission lines. The protective relays communicate current magnitude and phase information over the communications path to determine if the Fault is located in the protective zone. Quantities such as digital packet loss, bit error rate and channel delay are monitored to determine the quality of the channel. These limits are determined and

set during relay commissioning. Once set, any channel quality problems that fall outside the set levels will indicate an alarm.

The previous examples show how some protective relay communications channels can be monitored and how the channel performance can be compared to performance criteria established by the entity. This standard does not state what the performance criteria will be; it just requires that the entity establish nominal criteria so Protection System channel monitoring can be performed.

How is the performance criteria of Protection System communications equipment involved in the maintenance program?

An entity determines the acceptable performance criteria, depending on the technology implemented. If the communications channel performance of a Protection System varies from the pre-determined performance criteria for that system, then these results should be investigated and resolved.

How do I verify the A/D converters of microprocessor-based relays?

There are a variety of ways to do this. Two examples would be: using values gathered via data communications and automatically comparing these values with values from other sources, or using groupings of other measurements (such as vector summation of bus feeder currents) for comparison. Many other methods are possible.

15.6 Alarms (Table 2)

In addition to the tables of maintenance for the components of a Protection System, there is an additional table added for alarms. This additional table was added for clarity. This enabled the common alarm attributes to be consolidated into a single spot, and, thus, make it easier to read the Tables 1-1 through 1-5, Table 3, and Table 4. The alarms need to arrive at a site wherein a corrective action can be initiated. This could be a control room, operations center, etc. The alarming mechanism can be a standard alarming system or an auto-polling system; the only requirement is that the alarm be brought to the action-site within 24 hours. This effectively makes manned-stations equivalent to monitored stations. The alarm of a monitored point (for example a monitored trip path with a lamp) in a manned-station now makes that monitored point eligible for monitored status. Obviously, these same rules apply to a non-manned-station, which is that if the monitored point has an alarm that is auto-reported to the operations center (for example) within 24 hours, then it too is considered monitored.

15.6.1 Frequently Asked Questions:

Why are there activities defined for varying degrees of monitoring a Protection System component when that level of technology may not yet be available?

There may already be some equipment available that is capable of meeting the highest levels of monitoring criteria listed in the Tables. However, even if there is no equipment available today that can meet this level of monitoring the standard establishes the necessary requirements for when such equipment becomes available. By creating a roadmap for development, this provision makes the standard technology neutral. The Standard Drafting Team wants to avoid the need to revise the standard in a few years to accommodate technology advances that may be coming to the industry.

Does a fail-safe “form b” contact that is alarmed to a 24/7 operation center classify as an alarm path with monitoring?

If the fail-safe “form-b” contact that is alarmed to a 24/7 operation center causes the alarm to activate for failure of any portion of the alarming path from the alarm origin to the 24/7 operations center, then this can be classified as an alarm path with monitoring.

15.7 Distributed UFLS and Distributed UVLS Systems (Table 3)

Distributed UFLS and distributed UVLS systems have their maintenance activities documented in Table 3 due to their distributed nature allowing reduced maintenance activities and extended maximum maintenance intervals. Relays have the same maintenance activities and intervals as Table 1-1. Voltage and current-sensing devices have the same maintenance activity and interval as Table 1-3. DC systems need only have their voltage read at the relay every 12 years. Control circuits have the following maintenance activities every 12 years:

- Verify the trip path between the relay and lock-out and/or auxiliary tripping device(s).
- Verify operation of any lock-out and/or auxiliary tripping device(s) used in the trip circuit.
- No verification of trip path required between the lock-out (and/or auxiliary tripping device) and the non-BES interrupting device.
- No verification of trip path required between the relay and trip coil for circuits that have no lock-out and/or auxiliary tripping device(s).
- No verification of trip coil required.

No maintenance activity is required for associated communication systems for distributed UFLS and distributed UVLS schemes.

Non-BES interrupting devices that participate in a distributed UFLS or distributed UVLS scheme are excluded from the tripping requirement, and part of the control circuit test requirement; however, the part of the trip path control circuitry between the Load-Shed relay and lock-out or auxiliary tripping relay must be tested at least once every 12 years. In the case where there is no lock-out or auxiliary tripping relay used in a distributed UFLS or UVLS scheme which is not part of the BES, there is no control circuit test requirement. There are many circuit interrupting devices in the distribution system that will be operating for any given under-frequency event that requires tripping for that event. A failure in the tripping action of a single distributed system circuit breaker (or non-BES equipment interruption device) will be far less significant than, for example, any single transmission Protection System failure, such as a failure of a bus differential lock-out relay. While many failures of these distributed system circuit breakers (or non-BES equipment interruption device) could add up to be significant, it is also believed that many circuit breakers are operated often on just Fault clearing duty; and, therefore, these circuit breakers are operated at least as frequently as any requirements that appear in this standard.

There are times when a Protection System component will be used on a BES device, as well as a non-BES device, such as a battery bank that serves both a BES circuit breaker and a non-BES interrupting device used for UFLS. In such a case, the battery bank (or other Protection System component) will be subject to the Tables of the standard because it is used for the BES.

15.7.1 Frequently Asked Questions:

The standard reaches further into the distribution system than we would like for UFLS and UVLS

While UFLS and UVLS equipment are located on the distribution network, their job is to protect the Bulk Electric System. This is not beyond the scope of NERC's 215 authority.

FPA section 215(a) definitions section defines bulk power system as: "(A) facilities and control Systems necessary for operating an interconnected electric energy transmission network (or any portion thereof)." That definition, then, is limited by a later statement which adds the term bulk power system "...does not include facilities used in the local distribution of electric energy." Also, Section 215 also covers users, owners, and operators of bulk power Facilities.

UFLS and UVLS (when the UVLS is installed to prevent system voltage collapse or voltage instability for BES reliability) are not "used in the local distribution of electric energy," despite their location on local distribution networks. Further, if UFLS/UVLS Facilities were not covered by the reliability standards, then in order to protect the integrity of the BES during under-frequency or under-voltage events, that Load would have to be shed at the Transmission bus to ensure the Load-generation balance and voltage stability is maintained on the BES.

15.8 Automatic Reclosing (Table 4)

Please see the document referenced in Section F of PRC-005-3, "Considerations for Maintenance and Testing of Autoreclosing Schemes — November 2012", for a discussion of Automatic Reclosing as addressed in PRC-005-3.

15.8.1 Frequently-asked Questions

Automatic Reclosing is a control, not a protective function; why then is Automatic Reclosing maintenance included in the Protection System Maintenance Program (PSMP)?

Automatic Reclosing is a control function. The standard's title 'Protection System and Automatic Reclosing Maintenance' clearly distinguishes (separates) the Automatic Reclosing from the Protection System. Automatic Reclosing is included in the PSMP because it is a more pragmatic approach as compared to creating a parallel and essentially identical 'Control System Maintenance Program' for the two Automatic Reclosing component types.

When do I need to have the initial maintenance of Automatic Reclosing Components completed upon change of the largest BES generating unit in the BA/RSG?

The maintenance interval, for newly identified Automatic Reclosing Components, starts when a change in the largest BES generating unit is determined by the BA/RSG. The first maintenance records for newly identified Automatic Reclosing Components should be dated no later than the maximum maintenance interval after the identification date. The maximum maintenance intervals for each newly identified Component are defined in Table 4. No activities or records are required prior to the date of identification.

Our maintenance practice consists of initiating the Automatic Reclosing relay and confirming the breaker closes properly and the close signal is released. This practice verifies the control circuitry associated with Automatic Reclosing. Do you agree?"

The described task partially verifies the control circuit maintenance activity. To meet the control circuit maintenance activity, responsible entities need to verify, *upon initiation*, that the reclosing relay does not issue a *premature closing command*. As noted on page 12 of the SAMS/SPCS report, the concern being addressed within the standard is premature auto reclosing that has the potential to cause generating unit or plant instability. Reclosing applications have many variations, responsible entities will need to verify the applicability of associated supervision/conditional logic and the reclosing relay operation; then verify the conditional logic or that the reclosing relay performs in a manner that does not result in a *premature closing command* being issued.

Some examples of conditions which can result in a premature closing command are: an improper supervision or conditional logic input which provides a false state and allows the reclosing relay to issue an improper close command based on incorrect conditions (i.e. voltage supervision, equipment status, sync window verification); timers utilized for closing actuation or reclosing arming/disarming circuitry which could allow the reclosing relay to issue an improper close command; a reclosing relay output contact failure which could result in a made-up-close condition / failure-to-release condition.

Why was a close-in three phase fault present for twice the normal clearing time chosen for the Automatic Reclosing exclusion? It exceeds TPL requirements and ignores the breaker closing time in a trip-close-trip sequence, thus making the exclusion harder to attain.

This condition represents a situation where a close signal is issued with no time delay or with less time delay than is intended, such as if a reclosing contact is welded closed. This failure mode can result in a minimum trip-close-trip sequence with the two faults cleared in primary protection operating time, and the open time between faults equal to the breaker closing cycle time. The sequence for this failure mode results in system impact equivalent to a high-speed autoreclosing sequence with no delay added in the autoreclosing logic. It represents a failure mode which must be avoided because it exceeds TPL requirements.

Do we have to test the various breaker closing circuit interlocks and controls such as anti-pump?

These components are not specifically addressed within Table 4, and need not be individually tested. They are indirectly verified by performing the Automatic Reclosing control circuitry verification as established in Table 4.

For Automatic Reclosing that is not part of an RAS, do we have to close the circuit breaker periodically?

No. For this application, you need only to verify that the Automatic Reclosing, upon initiation, does not issue a premature closing command. This activity is concerned only with assuring that a premature close does not occur, and cause generating plant instability.

For Automatic Reclosing that is part of an RAS, do we have to close the circuit breaker periodically?

Yes. In this application, successful closing is a necessary portion of the RAS, and must be verified.

Why is maintenance of supervisory relays now included in PRC-005 for Automatic Reclosing?

Proper performance of supervising relays supports the reliability of the BES because some conditions can result in a premature closing command. An example of this would be an improper supervision or conditional logic input which provides a false state and allows the reclosing relay to issue an improper close command based on incorrect conditions (i.e. voltage supervision, sync window verification)

My reclosing circuitry contains the following inputs listed below; what supervising relays would need to be tested per PRC-005?

- 79/ON – Supervisory contact which turns Automatic reclosing ON or OFF
- 52 – Supervisory contact which provides breaker indication (“b” contact)
- 86 - Supervisory contact from a lockout relay
- 79 – Supervisory contact from a reclosing relay
- 25 – Supervisory contact from a sync-check relay
- 27 or 59 – Supervisory contact from a undervoltage of overvoltage relay

Supervising Relays are defined in this standard as “relay(s) that perform voltage and/or sync check functions that enables or disables operation of the reclosing relay.” The 79/ON, 52, and 86 would not need to be included. However, the 79, 25, and 27 or 59 would be included because they are supervisory devices that are either associated with autoreclosing, sync-checks, and/or voltage.

The sync check and voltage check functions are part of my microprocessor reclosing relay. Are there any test requirements for these internal supervisory functions?

A microprocessor reclosing relay that is using internal sync check or voltage check supervisory functions is a combinational reclosing and supervisory relay (i.e. 79/25). The maintenance activities for both a reclosing relay and supervisory relay would apply. The voltage sensing devices providing input to a combinational reclosing and supervisory relay would require the activities in Table 4-3.

Is it necessary to verify the close signal operates the breaker?

Only when the control circuitry associated with automatic reclosing is a part of a RAS, then all paths that are essential for proper operation of the RAS must be verified, per table 4-2(b).

15.9 Sudden Pressure Relaying (Table 5)

Please see the document referenced in Section F of PRC-005-4, “Sudden Pressure Relays and Other Devices that Respond to Non-Electrical Quantities – December 2013”, for a discussion of Sudden Pressure Relaying as addressed in PRC-005-4.

15.9.1 Frequently Asked Questions:

How do I verify the pressure or flow sensing mechanism is operable?

Maintenance activities for the fault pressure relay associated with Sudden Pressure Relaying in PRC-005-4 are intended to verify that the pressure and/or flow sensing mechanism are functioning correctly. Beyond this, PRC-005-4 requires no calibration (adjusting the operating threshold or measurement accuracy of a measuring element to meet the intended performance requirement) or testing (applying signals to a component to observe functional performance or output behavior, or to diagnose problems) activities. For example, some designs of flow sensing mechanisms allow the operation of a test switch to actuate the limit switch of the flow sensing mechanism. Operation of this test switch and verification of the flow sensing mechanism would meet the requirements of the maintenance activity. Another example involves a gas pressure sensing mechanism which is isolated by a test plug. Removal of the plug and verification of the bellows mechanism would meet the requirements of the maintenance activity.

Why the 6-year maximum maintenance interval for fault pressure relays?

The SDT established the six-year maintenance interval for fault pressure relays (see Table 5, PRC-005-4) based on the recommendation of the System Protection and Control Subcommittee (SPCS). The technical experts of the SPCS were tasked with developing the technical documents to:

- i. Describe the devices and functions (to include sudden pressure relays which trip for fault conditions) that should address FERC's concern; and
- ii. Propose minimum maintenance activities for such devices and maximum maintenance intervals, including the technical basis for each.

Excerpt from the [SPCS technical report](#): "In order to determine present industry practices related to sudden pressure relay maintenance, the SPCS conducted a survey of Transmission Owners and Generator Owners in all eight Regions requesting information related to their maintenance practices. The SPCS received responses from 75 Transmission Owners and 109 Generator Owners. Note that, for the purpose of the survey, sudden pressure relays included the following: the "sudden pressure relay" (SPR) originally manufactured by Westinghouse, the "rapid pressure rise relay" (RPR) manufactured by Qualitrol, and a variety of Buchholz relays.

Table 2 provides a summary of the results of the responses:

Table 2: Sudden Pressure Relay Maintenance Practices – Survey Results		
	Transmission Owner	Generator Owner
Number of responding owners that trip with Sudden Pressure Relays:	67	84
Percentage of responding owners who trip that have a Maintenance Program:	75%	78%
Percentage of maintenance programs that include testing the pressure actuator:	81%	77%

Average Maintenance interval reported:	5.9 years	4.9 years
--	-----------	-----------

Additionally, in order to validate the information noted above, the SPCS contacted the following entities for their feedback: the IEEE Power System Relaying Committee, the IEEE Transformer Committee, the Doble Transformer Committee, the NATF System Protection Practices Group, and the EPRI Generator Owner/Operator Technical Focus Group. All of these organizations indicated the results of the SPCS survey are consistent with their respective experiences.

The SPCS discussed the potential difference between the recommended intervals for fault pressure relaying and intervals for transformer maintenance. The SPCS developed the recommended intervals for fault pressure relaying by comparing fault pressure relaying to Protection System Components with similar physical attributes. The SPCS recognized that these intervals may be shorter than some existing or future transformer maintenance intervals, but believed it to be more important to base intervals for fault pressure relaying on similar Protection System Components than transformer maintenance intervals.

The maintenance interval for fault pressure relays can be extended by utilizing performance-based maintenance thereby allowing entities that have maintenance intervals for transformers in excess of six years, to align them.

Sudden Pressure Relaying control circuitry is now specifically mentioned in the maintenance tables. Do we have to trip our circuit breaker specifically from the trip output of the sudden pressure relay?

No. Verification may be by breaker tripping, but may be verified in overlapping segments with the Protection System control circuitry.

Can we use Performance Based Maintenance for fault pressure relays?

Yes. Performance Based Maintenance is applicable to fault pressure relays.

15.10 Examples of Evidence of Compliance

To comply with the requirements of this standard, an entity will have to document and save evidence. The evidence can be of many different forms. The Standard Drafting Team recognizes that there are concurrent evidence requirements of other NERC standards that could, at times, fulfill evidence requirements of this standard.

15.10.1 Frequently Asked Questions:

What forms of evidence are acceptable?

Acceptable forms of evidence, as relevant for the requirement being documented include, but are not limited to:

- Process documents or plans
- Data (such as relay settings sheets, photos, SCADA, and test records)
- Database lists, records and/or screen shots that demonstrate compliance information
- Prints, diagrams and/or schematics
- Maintenance records

-
- Logs (operator, substation, and other types of log)
 - Inspection forms
 - Mail, memos, or email proving the required information was exchanged, coordinated, submitted or received
 - Check-off forms (paper or electronic)
 - Any record that demonstrates that the maintenance activity was known, accounted for, and/or performed.

If I replace a failed Protection System component with another component, what testing do I need to perform on the new component?

In order to reset the Table 1 maintenance interval for the replacement component, all relevant Table 1 activities for the component should be performed.

I have evidence to show compliance for PRC-016 (“Special Protection System Misoperation”). Can I also use it to show compliance for this Standard, PRC-005-4?

Maintaining evidence for operation of Remedial Action Schemes could concurrently be utilized as proof of the operation of the associated trip coil (provided one can be certain of the trip coil involved). Thus, the reporting requirements that one may have to do for the Misoperation of a Special Protection Scheme under PRC-016 could work for the activity tracking requirements under this PRC-005-4.

I maintain Disturbance records which show Protection System operations. Can I use these records to show compliance?

These records can be concurrently utilized as dc trip path verifications, to the degree that they demonstrate the proper function of that dc trip path.

I maintain test reports on some of my Protection System components. Can I use these test reports to show that I have verified a maintenance activity?

Yes. References

1. [Protection System Maintenance: A Technical Reference](#). Prepared by the System Protection and Controls Task Force of the NERC Planning Committee. Dated September 13, 2007.
2. “Predicating The Optimum Routine test Interval For Protection Relays,” by J. J. Kumm, M.S. Weber, D. Hou, and E. O. Schweitzer, III, IEEE Transactions on Power Delivery, Vol. 10, No. 2, April 1995.
3. “Transmission Relay System Performance Comparison For 2000, 2001, 2002, 2003, 2004 and 2005,” Working Group I17 of Power System Relaying Committee of IEEE Power Engineering Society, May 2006.
4. “A Survey of Relaying Test Practices,” Special Report by WG I11 of Power System Relaying Committee of IEEE Power Engineering Society, September 16, 1999.
5. “Transmission Protective Relay System Performance Measuring Methodology,” Working Group I3 of Power System Relaying Committee of IEEE Power Engineering Society, January 2002.

-
6. "Processes, Issues, Trends and Quality Control of Relay Settings," Working Group C3 of Power System Relaying Committee of IEEE Power Engineering Society, December 2006.
 7. "Proposed Statistical Performance Measures for Microprocessor-Based Transmission-Line Protective Relays, Part I - Explanation of the Statistics, and Part II - Collection and Uses of Data," Working Group D5 of Power System Relaying Committee of IEEE Power Engineering Society, May 1995; Papers 96WM 016-6 PWRD and 96WM 127-1 PWRD, 1996 IEEE Power Engineering Society Winter Meeting.
 8. "Analysis And Guidelines For Testing Numerical Protection Schemes," Final Report of CIGRE WG 34.10, August 2000.
 9. "Use of Preventative Maintenance and System Performance Data to Optimize Scheduled Maintenance Intervals," H. Anderson, R. Loughlin, and J. Zipp, Georgia Tech Protective Relay Conference, May 1996.
 10. "Battery Performance Monitoring by Internal Ohmic Measurements" EPRI Application Guidelines for Stationary Batteries TR- 108826 Final Report, December 1997.
 11. "IEEE Recommended Practice for Maintenance, Testing, and Replacement of Valve-Regulated Lead-Acid (VRLA) Batteries for Stationary Applications," IEEE Power Engineering Society Std 1188 – 2005.
 12. "IEEE Recommended Practice for Maintenance, Testing, and Replacement of Vented Lead-Acid Batteries for Stationary Applications," IEEE Power & Engineering Society Std 45-2010.
 13. "IEEE Recommended Practice for Installation design and Installation of Vented Lead-Acid Batteries for Stationary Applications," IEEE Std 484 – 2002.
 14. "Stationary Battery Monitoring by Internal Ohmic Measurements," EPRI Technical Report, 1002925 Final Report, December 2002.
 15. "Stationary Battery Guide: Design Application, and Maintenance" EPRI Revision 2 of TR-100248, 1006757, August 2002.

PSMT SDT References

16. "Essentials of Statistics for Business and Economics" Anderson, Sweeney, Williams, 2003
17. "Introduction to Statistics and Data Analysis" - Second Edition, Peck, Olson, Devore, 2005
18. "Statistical Analysis for Business Decisions" Peters, Summers, 1968
19. "Considerations for Maintenance and Testing of Autoreclosing Schemes," NERC System Analysis and Modeling Subcommittee and NERC System Protection and Control Subcommittee, November 2012

Figures

Figure 1: Typical Transmission System

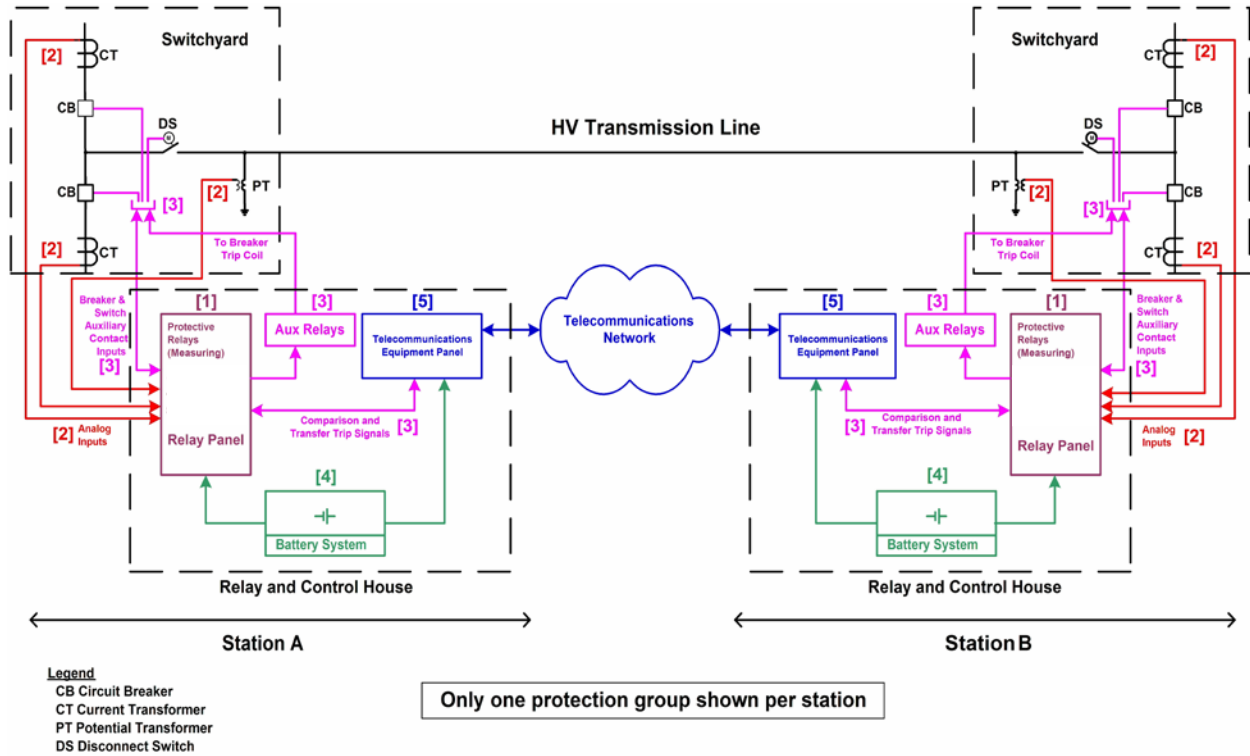

For information on components, see [Figure 1 & 2 Legend – components of Protection Systems](#)

Figure 2: Typical Generation System

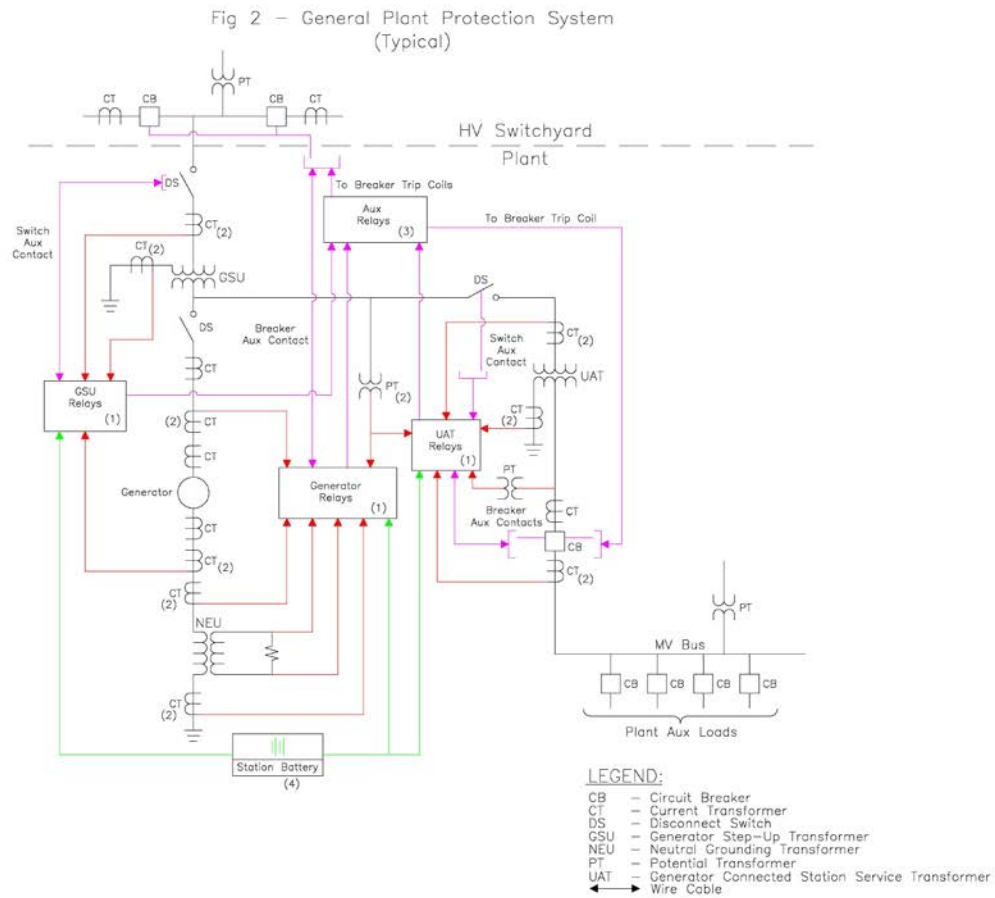

Note: Figure 2 may show elements that are not included within PRC-005-2, and also may not be all-inclusive; see the Applicability section of the standard for specifics.

For information on components, see [Figure 1 & 2 Legend – components of Protection Systems](#)

Figure 1 & 2 Legend – Components of Protection Systems

Number in Figure	Component of Protection System	Includes	Excludes
1	Protective relays which respond to electrical quantities	All protective relays that use current and/or voltage inputs from current & voltage sensors and that trip the 86, 94 or trip coil.	Devices that use non-electrical methods of operation including thermal, pressure, gas accumulation, and vibration. Any ancillary equipment not specified in the definition of Protection Systems. Control and/or monitoring equipment that is not a part of the automatic tripping action of the Protection System
2	Voltage and current sensing devices providing inputs to protective relays	The signals from the voltage & current sensing devices to the protective relay input.	Voltage & current sensing devices that are not a part of the Protection System, including, metering systems and data acquisition systems.
3	Control circuitry associated with protective functions	All control wiring (or other medium for conveying trip signals) associated with the tripping action of 86 devices, 94 devices or trip coils (from all parallel trip paths). This would include fiber-optic systems that carry a trip signal as well as hard-wired systems that carry trip current.	Closing circuits, SCADA circuits, other devices in control scheme not passing trip current
4	Station dc supply	Batteries and battery chargers and any control power system which has the function of supplying power to the protective relays, associated trip circuits and trip coils.	Any power supplies that are not used to power protective relays or their associated trip circuits and trip coils.
5	Communications systems necessary for correct operation of protective functions	Tele-protection equipment used to convey specific information, in the form of analog or digital signals, necessary for the correct operation of protective functions.	Any communications equipment that is not used to convey information necessary for the correct operation of protective functions.

[Additional information can be found in References](#)

Appendix A

The following illustrates the concept of overlapping verifications and tests as summarized in Section 10 of the paper. As an example, Figure A-1 shows protection for a critical transmission line by carrier blocking directional comparison pilot relaying. The goal is to verify the ability of the entire two-terminal pilot protection scheme to protect for line faults, and to avoid over-tripping for faults external to the transmission line zone of protection bounded by the current transformer locations.

Figure A-1

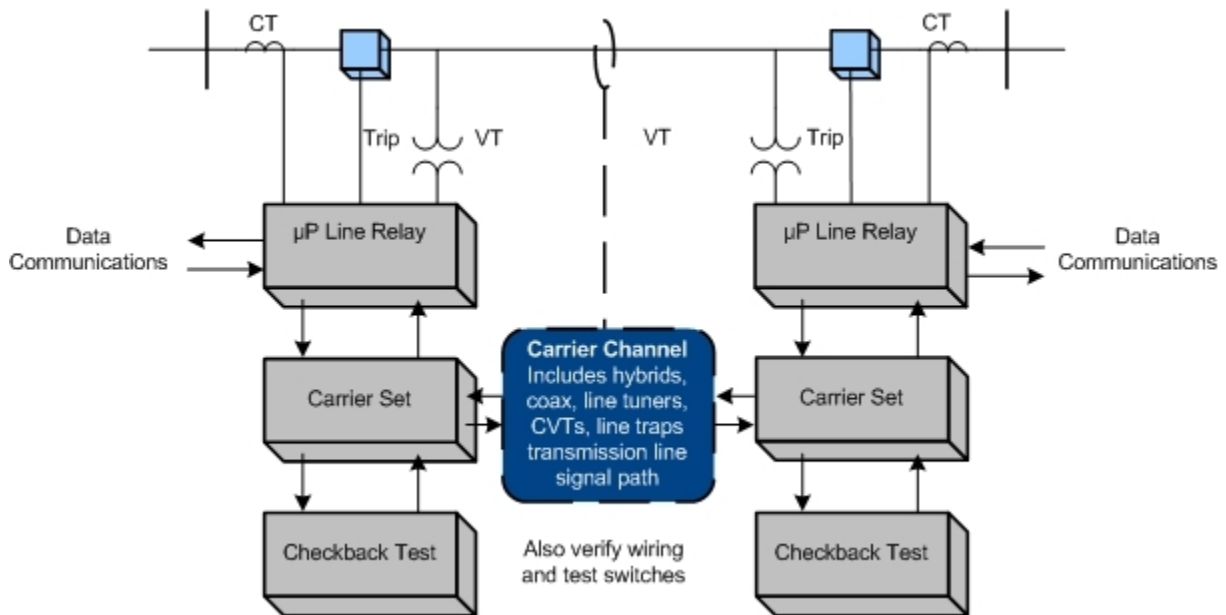

In this example (Figure A1), verification takes advantage of the self-monitoring features of microprocessor multifunction line relays at each end of the line. For each of the line relays themselves, the example assumes that the user has the following arrangements in place:

1. The relay has a data communications port that can be accessed from remote locations.
2. The relay has internal self-monitoring programs and functions that report failures of internal electronics, via communications messages or alarm contacts to SCADA.
3. The relays report loss of dc power, and the relays themselves or external monitors report the state of the dc battery supply.
4. The CT and PT inputs to the relays are used for continuous calculation of metered values of volts, amperes, plus Watts and VARs on the line. These metered values are reported by data communications. For maintenance, the user elects to compare these readings to those of other relays, meters, or DFRs. The other readings may be from redundant relaying or measurement systems or they may be derived from values in other protection zones. Comparison with other such readings to within required relaying accuracy verifies voltage & current sensing devices, wiring, and analog signal input processing of the relays. One

effective way to do this is to utilize the relay metered values directly in SCADA, where they can be compared with other references or state estimator values.

5. Breaker status indication from auxiliary contacts is verified in the same way as in (2). Status indications must be consistent with the flow or absence of current.
6. Continuity of the breaker trip circuit from dc bus through the trip coil is monitored by the relay and reported via communications.
7. Correct operation of the on-off carrier channel is also critical to security of the Protection System, so each carrier set has a connected or integrated automatic checkback test unit. The automatic checkback test runs several times a day. Newer carrier sets with integrated checkback testing check for received signal level and report abnormal channel attenuation or noise, even if the problem is not severe enough to completely disable the channel.

These monitoring activities plus the check-back test comprise automatic verification of all the Protection System elements that experience tells us are the most prone to fail. But, does this comprise a complete verification?

Figure A-2

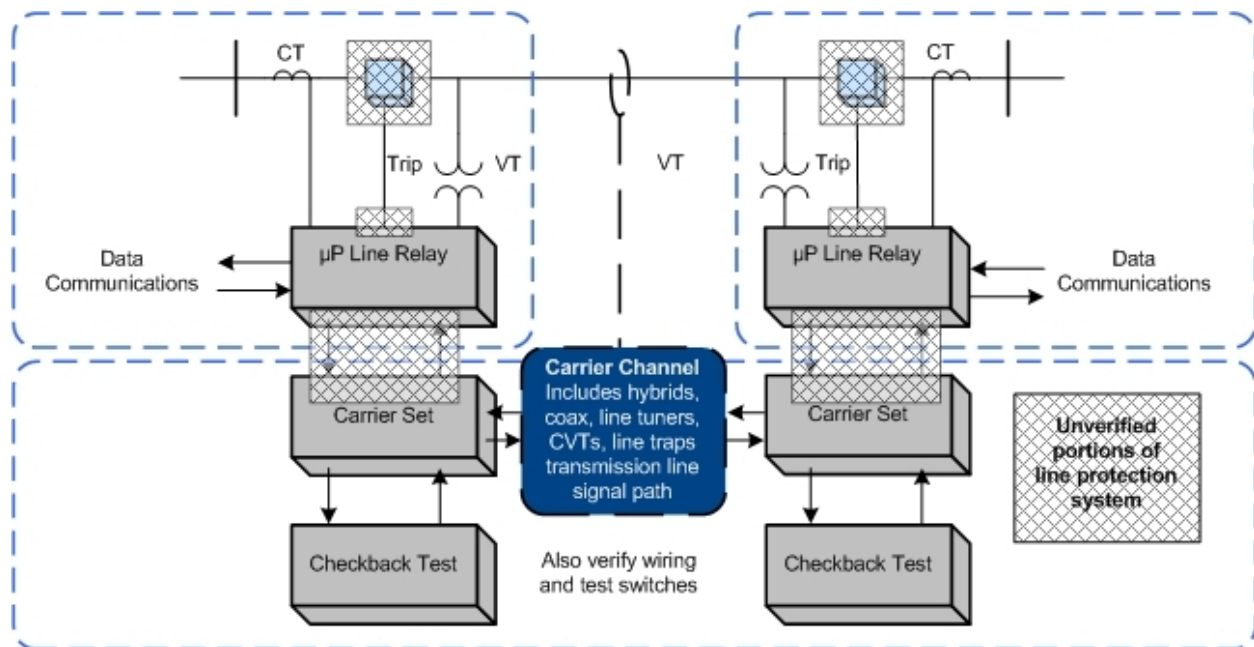

The dotted boxes of Figure A-2 show the sections of verification defined by the monitoring and verification practices just listed. These sections are not completely overlapping, and the shaded regions show elements that are not verified:

1. The continuity of trip coils is verified, but no means is provided for validating the ability of the circuit breaker to trip if the trip coil should be energized.

-
2. Within each line relay, all the microprocessors that participate in the trip decision have been verified by internal monitoring. However, the trip circuit is actually energized by the contacts of a small telephone-type "ice cube" relay within the line protective relay. The microprocessor energizes the coil of this ice cube relay through its output data port and a transistor driver circuit. There is no monitoring of the output port, driver circuit, ice cube relay, or contacts of that relay. These components are critical for tripping the circuit breaker for a Fault.
 3. The check-back test of the carrier channel does not verify the connections between the relaying microprocessor internal decision programs and the carrier transmitter keying circuit or the carrier receiver output state. These connections include microprocessor I/O ports, electronic driver circuits, wiring, and sometimes telephone-type auxiliary relays.
 4. The correct states of breaker and disconnect switch auxiliary contacts are monitored, but this does not confirm that the state change indication is correct when the breaker or switch opens.

A practical solution for (1) and (2) is to observe actual breaker tripping, with a specified maximum time interval between trip tests. Clearing of naturally-occurring Faults are demonstrations of operation that reset the time interval clock for testing of each breaker tripped in this way. If Faults do not occur, manual tripping of the breaker through the relay trip output via data communications to the relay microprocessor meets the requirement for periodic testing.

PRC-005-4 does not address breaker maintenance, and its Protection System test requirements can be met by energizing the trip circuit in a test mode (breaker disconnected) through the relay microprocessor. This can be done via a front-panel button command to the relay logic, or application of a simulated Fault with a relay test set. However, utilities have found that breakers often show problems during Protection System tests. It is recommended that Protection System verification include periodic testing of the actual tripping of connected circuit breakers.

Testing of the relay-carrier set interface in (3) requires that each relay key its transmitter, and that the other relay demonstrate reception of that blocking carrier. This can be observed from relay or DFR records during naturally occurring Faults, or by a manual test. If the checkback test sequence were incorporated in the relay logic, the carrier sets and carrier channel are then included in the overlapping segments monitored by the two relays, and the monitoring gap is completely eliminated.

Appendix B

Protection System Maintenance Standard Drafting Team

Charles W. Rogers
Chairman
Consumers Energy Co.

John B. Anderson
Xcel Energy

Stephen Crutchfield
NERC

Forrest Brock
Western Farmers Electric Cooperative

John Schecter
American Electric Power

Aaron Feathers
Pacific Gas and Electric Company

William D. Shultz
Southern Company Generation

Sam Francis
Oncor Electric Delivery

Philip B. Winston
Southern Company Transmission

James M. Kinney
FirstEnergy Corporation

Scott Vaughan
City of Roseville Electric Department

Kristina Marriott
ENOSERV

Matthew Westrich
American Transmission Company

NERC

NORTH AMERICAN ELECTRIC
RELIABILITY CORPORATION

Supplementary Reference and FAQ

PRC-005-4 Protection System Maintenance and
Testing

April 2015 ~~October 2014~~

RELIABILITY | ACCOUNTABILITY



3353 Peachtree Road NE
Suite 600, North Tower
Atlanta, GA 30326
404-446-2560 | www.nerc.com

Table of Contents

Table of Contents	ii
1. Introduction and Summary	1
2. Need for Verifying Protection System Performance	2
2.1 Existing NERC Standards for Protection System Maintenance and Testing.....	2
2.2 Protection System Definition.....	3
2.3 Applicability of New Protection System Maintenance Standards.....	3
2.3.1 Frequently Asked Questions:.....	4
2.4.1 Frequently Asked Questions:.....	6
3. Protection System and Automatic Reclosing Product Generations	15
4. Definitions.....	17
4.1 Frequently Asked Questions:.....	18
5. Time-Based Maintenance (TBM) Programs.....	20
5.1 Maintenance Practices	20
5.1.1 Frequently Asked Questions:	22
5.2 Extending Time-Based Maintenance	23
5.2.1 Frequently Asked Questions:	24
6. Condition-Based Maintenance (CBM) Programs.....	25
6.1 Frequently Asked Questions:.....	25
7. Time-Based Versus Condition-Based Maintenance.....	28
7.1 Frequently Asked Questions:.....	28
8. Maximum Allowable Verification Intervals	34
8.1 Maintenance Tests.....	34
8.1.1 Table of Maximum Allowable Verification Intervals.....	34

8.1.2 Additional Notes for Tables 1-1 through 1-5, Table 3, and Table 4.....	36
8.1.3 Frequently Asked Questions:	37
8.2 Retention of Records	42
8.2.1 Frequently Asked Questions:	43
8.3 Basis for Table 1 Intervals	45
8.4 Basis for Extended Maintenance Intervals for Microprocessor Relays	46
9. Performance-Based Maintenance Process.....	48
9.1 Minimum Sample Size.....	49
9.2 Frequently Asked Questions:.....	52
10. Overlapping the Verification of Sections of the Protection System.....	64
10.1 Frequently Asked Questions:.....	64
11. Monitoring by Analysis of Fault Records	65
11.1 Frequently Asked Questions:.....	66
12. Importance of Relay Settings in Maintenance Programs	67
12.1 Frequently Asked Questions:.....	67
13. Self-Monitoring Capabilities and Limitations	70
13.1 Frequently Asked Questions:.....	71
14. Notification of Protection System or Automatic Reclosing Failures	72
15. Maintenance Activities	73
15.1 Protective Relays (Table 1-1)	73
15.1.1 Frequently Asked Questions:	73
15.2 Voltage & Current Sensing Devices (Table 1-3)	73
15.2.1 Frequently Asked Questions:	75
15.3 Control circuitry associated with protective functions (Table 1-5)	76
15.3.1 Frequently Asked Questions:	77

15.4 Batteries and DC Supplies (Table 1-4).....	79
15.4.1 Frequently Asked Questions:	80
15.5 Associated communications equipment (Table 1-2).....	94
15.5.1 Frequently Asked Questions:	96
15.6 Alarms (Table 2).....	99
15.6.1 Frequently Asked Questions:	99
15.7 Distributed UFLS and Distributed UVLS Systems (Table 3).....	100
15.7.1 Frequently Asked Questions:	101
15.8 Automatic Reclosing (Table 4)	101
15.8.1 Frequently-asked Questions	101
15.9 Examples of Evidence of Compliance	103
15.9.1 Frequently Asked Questions:.....	105
References	106
Figures.....	108
Figure 1: Typical Transmission System	108
Figure 2: Typical Generation System	109
Figure 1 & 2 Legend – Components of Protection Systems	110
Appendix A.....	111
Appendix B	114
Protection System Maintenance Standard Drafting Team.....	114

1. Introduction and Summary

Note: This supplementary reference for PRC-005-4 is neither mandatory nor enforceable.

NERC currently has four Reliability Standards that are mandatory and enforceable in the United States and Canada and address various aspects of maintenance and testing of Protection and Control Systems.

These standards are:

PRC-005-1b — Transmission and Generation Protection System Maintenance and Testing

PRC-008-0 — Underfrequency Load Shedding Equipment Maintenance Programs

PRC-011-0 — UVLS System Maintenance and Testing

PRC-017-0 — Special Protection System Maintenance and Testing

While these standards require that applicable entities have a maintenance program for Protection Systems, and that these entities must be able to demonstrate they are carrying out such a program, there are no specifics regarding the technical requirements for Protection System maintenance programs. Furthermore, FERC Order 693 directed additional modifications respective to Protection System maintenance programs. PRC-005-3 will replace PRC-005-2 which combined and replaced PRC-005, PRC-008, PRC-011 and PRC-017. PRC-005-3 adds Automatic Reclosing to PRC-005-2. PRC-005-2 addressed these directed modifications and replaces PRC-005, PRC-008, PRC-011 and PRC-017.

FERC Order 758 further directed that maintenance of reclosing relays and sudden pressure relays that affect the reliable operation of the Bulk Power System be addressed. PRC-005-3 addresses this directive regarding reclosing relays, and, when approved, will supersede PRC-005-2. PRC-005-4 addresses this directive regarding sudden pressure relays and, when approved, will supersede PRC-005-3.

This document augments the Supplementary Reference and FAQ previously developed for PRC-005-2 by including discussion relevant to Automatic Reclosing added in PRC-005-3 and Sudden Pressure Relaying in PRC-005-4.

2. Need for Verifying Protection System Performance

Protective relays have been described as silent sentinels, and do not generally demonstrate their performance until a Fault or other power system problem requires that they operate to protect power system Elements, or even the entire Bulk Electric System (BES). Lacking Faults, switching operations or system problems, the Protection Systems may not operate, beyond static operation, for extended periods. A Misoperation - a false operation of a Protection System or a failure of the Protection System to operate, as designed, when needed - can result in equipment damage, personnel hazards, and wide-area Disturbances or unnecessary customer outages. Maintenance or testing programs are used to determine the performance and availability of Protection Systems.

Typically, utilities have tested Protection Systems at fixed time intervals, unless they had some incidental evidence that a particular Protection System was not behaving as expected. Testing practices vary widely across the industry. Testing has included system functionality, calibration of measuring devices, and correctness of settings. Typically, a Protection System must be visited at its installation site and, in many cases, removed from service for this testing.

Fundamentally, a Reliability Standard for Protection System Maintenance and Testing requires the performance of the maintenance activities that are necessary to detect and correct plausible age and service related degradation of the Protection System components, such that a properly built and commissioned Protection System will continue to function as designed over its service life.

Similarly station batteries, which are an important part of the station dc supply, are not called upon to provide instantaneous dc power to the Protection System until power is required by the Protection System to operate circuit breakers or interrupting devices to clear Faults or to isolate equipment.

2.1 Existing NERC Standards for Protection System Maintenance and Testing

For critical BES protection functions, NERC standards have required that each utility or asset owner define a testing program. The starting point is the existing Standard PRC-005, briefly restated as follows:

Purpose: To document and implement programs for the maintenance of all Protection Systems affecting the reliability of the Bulk Electric System (BES) so that these Protection Systems are kept in working order.

PRC-005-4 is not specific on where the boundaries of the Protection Systems lie. However, the definition of Protection System in the [NERC Glossary of Terms](#) used in Reliability Standards indicates what must be included as a minimum.

At the beginning of the project to develop PRC-005-2, the definition of Protection System was:

Protective relays, associated communications Systems, voltage and current sensing devices, station batteries and dc control circuitry.

Applicability: Owners of generation and transmission Protection Systems.

Requirements: The owner shall have a documented maintenance program with test intervals. The owner must keep records showing that the maintenance was performed at the specified intervals.

2.2 Protection System Definition

The most recently approved definition of Protection Systems is:

- Protective relays which respond to electrical quantities,
- Communications systems necessary for correct operation of protective functions,
- Voltage and current sensing devices providing inputs to protective relays,
- Station dc supply associated with protective functions (including station batteries, battery chargers, and non-battery-based dc supply), and
- Control circuitry associated with protective functions through the trip coil(s) of the circuit breakers or other interrupting devices.

2.3 Applicability of New Protection System Maintenance Standards

The BES purpose is to transfer bulk power. The applicability language has been changed from the original PRC-005:

“...affecting the reliability of the Bulk Electric System (BES)...”

To the present language:

“...that are installed for the purpose of detecting Faults on BES Elements (lines, buses, transformers, etc.).”

The drafting team intends that this standard will follow with any definition of the Bulk Electric System. There should be no ambiguity; if the Element is a BES Element, then the Protection System protecting that Element should then be included within this standard. If there is regional variation to the definition, then there will be a corresponding regional variation to the Protection Systems that fall under this standard.

There is no way for the Standard Drafting Team to know whether a specific 230KV line, 115KV line (even 69KV line), for example, should be included or excluded. Therefore, the team set the clear intent that the standard language should simply be applicable to Protection Systems for BES Elements.

The BES is a NERC defined term that, from time to time, may undergo revisions. Additionally, there may even be regional variations that are allowed in the present and future definitions. See the NERC Glossary of Terms for the present, in-force definition. See the applicable Regional Reliability Organization for any applicable allowed variations.

While this standard will undergo revisions in the future, this standard will not attempt to keep up with revisions to the NERC definition of BES, but, rather, simply make BES Protection Systems applicable.

The Standard is applied to Generator Owners (GO) and Transmission Owners (TO) because GOs and TOs have equipment that is BES equipment. The standard brings in Distribution Providers (DP) because, depending on the station configuration of a particular substation, there may be

Protection System equipment installed at a non-transmission voltage level (Distribution Provider equipment) that is wholly or partially installed to protect the BES. PRC-005-4 would apply to this equipment. An example is underfrequency load-shedding, which is frequently applied well down into the distribution system to meet PRC-007-0.

PRC-005-2 replaced the existing PRC-005, PRC-008, PRC-011 and PRC-017. Much of the original intent of those standards was carried forward whenever it was possible to continue the intent without a disagreement with FERC Order 693. For example, the original PRC-008 was constructed quite differently than the original PRC-005. The drafting team agrees with the intent of this and notes that distributed tripping schemes would have to exhibit multiple failures to trip before they would prove to be significant, as opposed to a single failure to trip of, for example, a transmission Protection System Bus Differential lock-out relay. While many failures of these distribution breakers could add up to be significant, it is also believed that distribution breakers are operated often on just Fault clearing duty; and, therefore, the distribution circuit breakers are operated at least as frequently as stipulated in any requirement in this standard.

Additionally, since PRC-005-2 replaced PRC-011, it will be important to make the distinction between under-voltage Protection Systems that protect individual Loads and Protection Systems that are UVLS schemes that protect the BES. Any UVLS scheme that had been applicable under PRC-011 is now applicable under PRC-005-2. An example of an under-voltage load-shedding scheme that is not applicable to this standard is one in which the tripping action was intended to prevent low distribution voltage to a specific Load from a Transmission system that was intact except for the line that was out of service, as opposed to preventing a Cascading outage or Transmission system collapse.

It had been correctly noted that the devices needed for PRC-011 are the very same types of devices needed in PRC-005.

Thus, a standard written for Protection Systems of the BES can easily make the needed requirements for Protection Systems, and replace some other standards at the same time.

2.3.1 Frequently Asked Questions:

What exactly is the BES, or Bulk Electric System?

BES is the abbreviation for Bulk Electric System. BES is a term in the Glossary of Terms used in Reliability Standards, and is not being modified within this draft standard.

Why is Distribution Provider included within the Applicable Entities and as a responsible entity within several of the requirements? Wouldn't anyone having relevant Facilities be a Transmission Owner?

Depending on the station configuration of a particular substation, there may be Protection System equipment installed at a non-transmission voltage level (Distribution Provider equipment) that is wholly or partially installed to protect the BES. PRC-005-4 applies to this equipment. An example is underfrequency load-shedding, which is frequently applied well down into the distribution system to meet PRC-007-0.

We have an under voltage load-shedding (UVLS) system in place that prevents one of our distribution substations from supplying extremely low voltage in the case of a specific transmission line outage. The transmission line is part of the BES. Does this mean that our UVLS system falls within this standard?

The situation, as stated, indicates that the tripping action was intended to prevent low distribution voltage to a specific Load from a Transmission System that was intact, except for the line that was out of service, as opposed to preventing Cascading outage or Transmission System Collapse.

This standard is not applicable to this UVLS.

We have a UFLS or UVLS scheme that sheds the necessary Load through distribution-side circuit breakers and circuit reclosers. Do the trip-test requirements for circuit breakers apply to our situation?

No. Distributed tripping schemes would have to exhibit multiple failures to trip before they would prove to be significant, as opposed to a single failure to trip of, for example, a transmission Protection System bus differential lock-out relay. While many failures of these distribution breakers could add up to be significant, it is also believed that distribution breakers are operated often on just Fault clearing duty; and, therefore, the distribution circuit breakers are operated at least as frequently as any requirements that might have appeared in this standard.

We have a UFLS scheme that, in some locales, sheds the necessary Load through non-BES circuit breakers and, occasionally, even circuit switchers. Do the trip-test requirements for circuit breakers apply to our situation?

If your “non-BES circuit breaker” has been brought into this standard by the inclusion of UFLS requirements, and otherwise would not have been brought into this standard, then the answer is that there are no trip-test requirements. For these devices that are otherwise non-BES assets, these tripping schemes would have to exhibit multiple failures to trip before they would prove to be as significant as, for example, a single failure to trip of a transmission Protection System bus differential lock-out relay.

How does the “Facilities” section of “Applicability” track with the standards that will be retired once PRC-005-2 becomes effective?

In establishing PRC-005-2, the drafting team combined legacy standards PRC-005-1b, PRC-008-0, PRC-011-0, and PRC-017-0. The merger of the subject matter of these standards is reflected in Applicability 4.2.

The intent of the drafting team is that the legacy standards be reflected in PRC-005-2 as follows:

- Applicability of PRC-005-1b for Protection Systems relating to non-generator elements of the BES is addressed in 4.2.1;
- Applicability of PRC-008-0 for underfrequency load shedding systems is addressed in 4.2.2;
- Applicability of PRC-011-0 for undervoltage load shedding relays is addressed in 4.2.3;
- Applicability of PRC-017-0 for Remedial Action Schemes is addressed in 4.2.4;
- Applicability of PRC-005-1b for Protection Systems for BES generators is addressed in 4.2.5 [and 4.2.6](#).

2.4 Applicable Relays

The NERC Glossary definition has a Protection System including relays, dc supply, current and voltage sensing devices, dc control circuitry and associated communications circuits. The relays to which this standard applies are those protective relays that respond to electrical quantities and provide a trip output to trip coils, dc control circuitry or associated communications equipment. This definition extends to IEEE Device No. 86 (lockout relay) and IEEE Device No. 94 (tripping or trip-free relay), as these devices are tripping relays that respond to the trip signal of the protective relay that processed the signals from the current and voltage-sensing devices.

Relays that respond to non-electrical inputs or impulses (such as, but not limited to, vibration, seismic, thermal or gas accumulation) are not included.

Automatic Reclosing is addressed in PRC-005-3 by explicitly addressing them outside the definition of Protection System. The specific locations for applicable Automatic Reclosing are addressed in Applicability Section 4.2.~~67~~.

Sudden Pressure Relaying is addressed in PRC-005-4 by explicitly addressing them outside the definition of Protection System. The specific locations for applicable Sudden Pressure Relaying are addressed in Applicability Section 4.2.1, 4.2.5.2~~7~~, 4.2.5.3, [and 4.2.6](#), ~~and 4.2.5.4~~.

2.4.1 Frequently Asked Questions:

Are power circuit reclosers, reclosing relays, closing circuits and auto-restoration schemes covered in this Standard?

Yes. Automatic Reclosing includes reclosing relays and the associated dc control circuitry. Section 4.2.~~76~~ of the Applicability specifically limits the applicable reclosing relays to:

4.2.~~76~~ Automatic Reclosing

4.2.~~76~~.1 Automatic Reclosing applied on the terminals of Elements connected to the BES bus located at generating plant substations where the total installed gross generating plant capacity is greater than the gross capacity of the largest BES generating unit within the Balancing Authority Area or, if a member of a Reserve Sharing Group, the largest generating unit within the Reserve Sharing Group.

4.2.~~76~~.2 Automatic Reclosing applied on the terminals of all BES Elements at substations one bus away from generating plants specified in Section 4.2.~~76~~.1

when the substation is less than 10 circuit-miles from the generating plant substation.

4.2.76.3 Automatic Reclosing applied as an integral part of an RAS specified in Section 4.2.4.

Further, Footnote 1 to Applicability Section 4.2.76 establishes that Automatic Reclosing addressed in 4.2.76.1 and 4.2.76.2 may be excluded if the equipment owner can demonstrate that a close-in three-phase fault present for twice the normal clearing time (capturing a minimum trip-close-trip time delay) does not result in a total loss of gross generation in the Interconnection exceeding the gross capacity of the largest relevant BES generating unit where the Automatic Reclosing is applied.

Additionally, Footnote 2 to Applicability Section 4.2.76.1 advises that the entity's PSMP needs to remain current regarding the applicability of Automatic Reclosing Components relative to the largest generating unit within the Balancing Authority Area or Reserve Sharing Group.

The Applicability as detailed above was recommended by the NERC System Analysis and Modeling Subcommittee (SAMS) after a lengthy review of the use of reclosing within the BES. SAMS concluded that automatic reclosing is largely implemented throughout the BES as an operating convenience, and that automatic reclosing mal-performance affects BES reliability only when the reclosing is part of a Remedial Action Schemes, or when premature autoreclosing has the potential to cause generating unit or plant instability. A technical report, "Considerations for Maintenance and Testing of Autoreclosing Schemes — November 2012", is referenced in PRC-005-3 and provides a more detailed discussion of these concerns.

Why did the standard drafting team not include IEEE device numbers to describe Automatic Reclosing Relays?

The drafting team elected not to include IEEE device numbers to describe Automatic Reclosing because Automatic Reclosing component type could be a stand-alone electromechanical relay; or could be the 79 function within a microprocessor based multi-function relay(11).

~~What is synchronizing or synchronism (Sync-Check – (25)) – check relay (Sync-Check - 25)?~~

~~A synchronizing device that produces an output that supervises causes closure of a circuit breaker between two circuits whose voltages are within prescribed limits of magnitude and, phase angle, and frequency. It may or may not include voltage or speed control. A sync-check relay permits the paralleling of two circuits that are within prescribed (usually wider) limits of voltage magnitude and, phase angle, and frequency.~~

~~Is a sync-check (25) relay included in the Automatic Reclosing Control Circuitry?~~

~~Where sync-check relays are included in an Automatic Reclosing scheme that is part of an RAS, the sync-check would be included in the control circuitry (Table 4-2(ab)).~~

~~Where sync-check relays are included in an Automatic Reclosing scheme that is not part of an RAS, the sync-check would not be included in the control circuitry (Table 4-2(a)).~~

~~The SDT asserts that a sync check (25) relay does not initiate closing but rather enables or disables closing and is not considered a part of the actual Automatic Reclosing control circuitry when not part of an RAS.~~

How do I interpret Applicability Section 4.2.76 to determine applicability in the following examples:

At my generating plant substation, I have a total of 800 MW connected to one voltage level and 200 MW connected to another voltage level. How do I determine my gross capacity? Where do I consider Automatic Reclosing to be applicable?

Scenario number 1:

The 800 MW of generation is connected to a BES voltage level bus, the 200 MW

is connected to a non-BES voltage level bus, and there is no connection between the two buses locally or within 10 circuit miles from the generating plant substation. The largest single unit in the BA area is 750 MW.

In this case, the total installed gross generating capacity would be 800 MW. The two units are essentially independent plants.

The BES voltage level bus is considered to be the bus to which the 800 MW of generation is connected. Any BES Automatic Reclosing at this location, as well as other locations within 10 circuit miles, is considered to be applicable because 800 MW exceeds the largest single unit in the BA area.

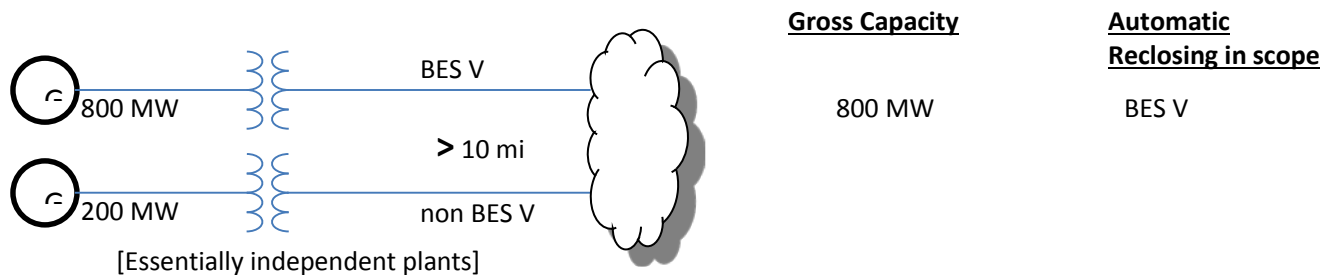

Scenario number 2:

The 800 MW of generation is connected to a BES voltage level bus, the 200 MW unit is connected to a non-BES voltage level bus, and there is a connection between the two buses locally or within 10 circuit miles from the generating plant substation. The largest single unit in the BA area is 750 MW.

In this case, reclosing into a fault on the BES system could impact the stability of the non-BES-connected generating units. Therefore, the total installed gross generating capacity would be 1000 MW.

The BES voltage level bus is considered to be the bus to which the 800 MW of generation is connected. Any BES Automatic Reclosing at this location, as well as other locations within 10 circuit miles, is considered to be applicable because total of 1000 MW exceeds the largest single unit in the BA area. However, the Automatic Reclosing on the non-BES voltage level bus is not applicable.

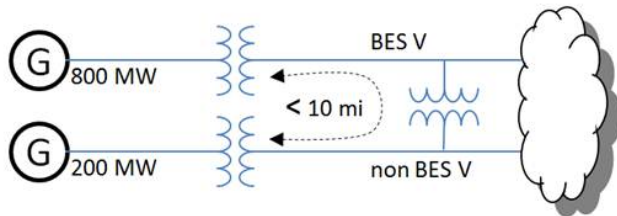

Gross Capacity

1000 MW

Automatic Reclosing in scope

BES V

Scenario number 3:

The 800 MW of generation is connected to a BES voltage level bus, the 200 MW unit is connected to a non-BES voltage level bus, and there is no connection between the two buses locally or within 10 circuit miles from the generating plant substation but the generating units connected at the BES voltage level do not operate independently of the units connected at the non BES voltage level (e.g., a combined cycle facility where 800 MW of combustion turbines are connected at a BES voltage level whose exhaust is used to power a 200 MW steam unit connected to a non BES voltage level. The largest single unit in the BA area is 750 MW.

In this case, the total installed gross generating capacity would be 1000 MW. Therefore, reclosing into a fault on the BES voltage level would result in a loss of the 800 MW combustion turbines and subsequently result in the loss of the 200 MW steam unit because of the loss of the heat source to its boiler.

The BES voltage level bus is considered to be the bus to which the 800 MW of generation is connected. Any BES Automatic Reclosing at this location, as well as other locations within 10 circuit miles, is considered to be applicable because total of 1000 MW exceeds the largest single unit in the BA area. However, the Automatic Reclosing on the non-BES voltage level bus is not applicable.

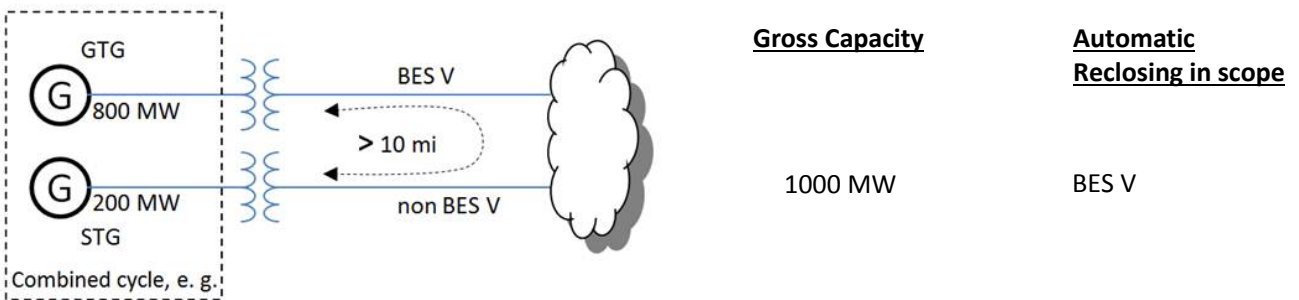

Scenario 4

The 800 MW of generation is connected at 345 kV and the 200 MW is connected at 138 kV with an autotransformer at the generating plant substation connecting the two voltage levels. The largest single unit in the BA area is 900 MW.

In this case, the total installed gross generating capacity would be 1000 MW and section 4.2.76.1 would be applicable to both the 345 kV Automatic Reclosing Components and the 138 kV Automatic Reclosing Components, since the total capacity of 1000 MW is larger than the largest single unit in the BA area.

However, if the 345 kV and the 138 kV systems can be shown to be uncoupled such that the 138 kV reclosing relays will not affect the stability of the 345 kV generating units then the 138 kV Automatic Reclosing Components need not be included per section 4.2.76.1.

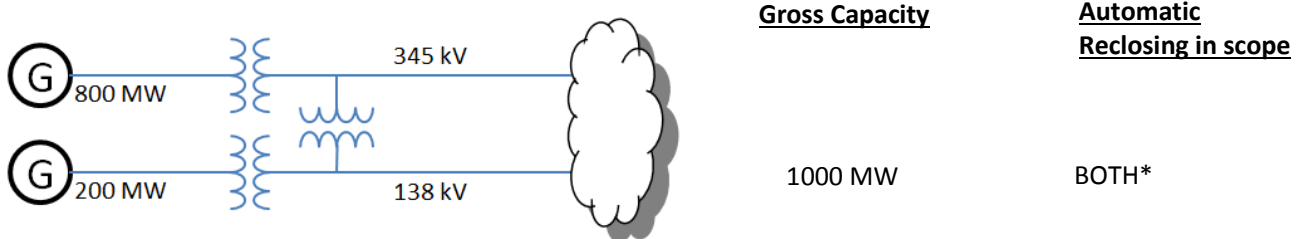

* The study detailed in Footnote 1 of the draft standard may eliminate the 138 kV Automatic Reclosing Components and/or the 345 kV Automatic Reclosing Components

Why does 4.2.76.2 specify “10 circuit miles”?

As noted in “Considerations for Maintenance and Testing of Autoreclosing Schemes — November 2012”, transmission line impedance on the order of one mile away typically provides adequate impedance to prevent generating unit instability and a 10 mile threshold provides sufficient margin.

Should I use MVA or MW when determining the installed gross generating plant capacity?

Be consistent with the rating used by the Balancing Authority for the largest BES generating unit within their area.

What value should we use for generating plant capacity in 4.2.76.1?

Use the value reported to the Balance Authority for generating plant capacity for planning and modeling purposes. This can be nameplate or other values based on generating plant limitations such as boiler or turbine ratings.

What is considered to be “one bus away” from the generation?

The BES voltage level bus is considered to be the generating plant substation bus to which the generator step-up transformer is connected. “One bus away” is the next bus, connected by either a transmission line or transformer.

I use my protective relays only as sources of metered quantities and breaker status for SCADA and EMS through a substation distributed RTU or data concentrator to the control center. What are the maintenance requirements for the relays?

This standard addresses Protection Systems that are installed for the purpose of detecting Faults on BES Elements (lines, buses, transformers, etc.). Protective relays, providing only the functions mentioned in the question, are not included.

Are Reverse Power Relays installed on the low-voltage side of distribution banks considered to be components of “Protection Systems that are installed for the purpose of detecting Faults on BES Elements (lines, buses, transformers, etc.)”?

Reverse power relays are often installed to detect situations where the transmission source becomes de-energized and the distribution bank remains energized from a source on the low-voltage side of the transformer and the settings are calculated based on the charging current of the transformer from the low-voltage side. Although these relays may operate as a result of a fault on a BES element, they are not ‘installed for the purpose of detecting’ these faults.

Why is the maintenance of Sudden Pressure Relaying being addressed in PRC-005-4?

Proper performance of Sudden Pressure Relaying supports the reliability of the BES because fault pressure relays can detect rapid changes in gas pressure, oil pressure, or oil flow that are indicative of faults within liquid-filled, wire-wound equipment such as turn-to-turn faults which may be undetected by Protection Systems. Additionally, Sudden Pressure

Relaying can quickly detect faults and operate to limit damage to liquid-filled, wire-wound equipment.

What type of devices are classified as fault pressure relay?

There are three main types of fault pressure relays; rapid gas pressure rise, rapid oil pressure rise, and rapid oil flow devices.

Rapid gas pressure devices monitor the pressure in the space above the oil (or other liquid), and initiate tripping action for a rapid rise in gas pressure resulting from the rapid expansion of the liquid caused by a fault. The sensor is located in the gas space.

Rapid oil pressure devices monitor the pressure in the oil (or other liquid), and initiate tripping action for a rapid pressure rise caused by a fault. The sensor is located in the liquid.

Rapid oil flow devices (“Buchholz”) monitor the liquid flow between a transformer/reactor and its conservator. Normal liquid flow occurs continuously with ambient temperature changes and with internal heating from loading and does not operate the rapid oil flow device. However, when an internal arc happens a sudden expansion of liquid can be monitored as rapid liquid flow from the transformer into the conservator resulting in actuation of the rapid oil flow device.

Are sudden pressure relays that only initiate an alarm included in the scope of PRC-005-4?

No, the definition of Sudden Pressure Relaying specifies only those that trip an interrupting device(s) to isolate the equipment it is monitoring.

Are pressure relief devices included in the scope of PRC-005-4?

No. PRDs are not included in the Sudden Pressure Relaying definition.

Is Sudden Pressure Relaying installed on distribution transformers included in PRC-005-4?

No, Applicability 4.2.1, ~~4.2.5.2, 4.2.5.3, 4.2.5.4, and 4.2.6~~, ~~4.2.5.4~~, explicitly describes what Sudden Pressure Relaying is included within the standard.

Are non-electrical sensing devices (other than fault pressure relays) such as low oil level or high winding temperatures included in PRC-005-4?

No, based on the SPCS technical document, “Sudden Pressure Relays and Other Devices that Respond to Non-Electrical Quantities – December 2013,” the only applicable non-electrical sensing devices are Sudden Pressure Relays.

The standard specifically mentions auxiliary and lock-out relays. What is an auxiliary tripping relay?

An auxiliary relay, IEEE Device No. 94, is described in IEEE Standard C37.2-2008 as: “A device that functions to trip a circuit breaker, contactor, or equipment; to permit immediate tripping by other devices; or to prevent immediate reclosing of a circuit interrupter if it should open automatically, even though its closing circuit is maintained closed.”

What is a lock-out relay?

A lock-out relay, IEEE Device No. 86, is described in IEEE Standard C37.2 as: “A device that trips and maintains the associated equipment or devices inoperative until it is reset by an operator, either locally or remotely.”

3. Protection System and Automatic Reclosing Product Generations

The likelihood of failure and the ability to observe the operational state of a critical Protection System and Automatic Reclosing both depend on the technological generation of the relays, as well as how long they have been in service. Unlike many other transmission asset groups, protection and control systems have seen dramatic technological changes spanning several generations. During the past 20 years, major functional advances are primarily due to the introduction of microprocessor technology for power system devices, such as primary measuring relays, monitoring devices, control Systems, and telecommunications equipment.

Modern microprocessor-based relays have six significant traits that impact a maintenance strategy:

- Self-monitoring capability - the processors can check themselves, peripheral circuits, and some connected substation inputs and outputs, such as trip coil continuity. Most relay users are aware that these relays have self-monitoring, but are not focusing on exactly what internal functions are actually being monitored. As explained further below, every element critical to the Protection System must be monitored, or else verified periodically.
- Ability to capture Fault records showing how the Protection System responded to a Fault in its zone of protection, or to a nearby Fault for which it is required not to operate.
- Ability to meter currents and voltages, as well as status of connected circuit breakers, continuously during non-Fault times. The relays can compute values, such as MW and MVAR line flows, that are sometimes used for operational purposes, such as SCADA.
- Data communications via ports that provide remote access to all of the results of Protection System monitoring, recording and measurement.
- Ability to trip or close circuit breakers and switches through the Protection System outputs, on command from remote data communications messages, or from relay front panel button requests.
- Construction from electronic components, some of which have shorter technical life or service life than electromechanical components of prior Protection System generations.

There have been significant advances in the technology behind the other components of Protection Systems. Microprocessors are now a part of battery chargers, associated communications equipment, voltage and current-measuring devices, and even the control circuitry (in the form of software-latches replacing lock-out relays, etc.).

Any Protection System component can have self-monitoring and alarming capability, not just relays. Because of this technology, extended time intervals can find their way into all components of the Protection System.

This standard also recognizes the distinct advantage of using advanced technology to justifiably defer or even eliminate traditional maintenance. Just as a hand-held calculator does not require routine testing and calibration, neither does a calculation buried in a microprocessor-based device that results in a “lock-out.” Thus, the software-latch 86 that replaces an electro-mechanical 86 does not require routine trip testing. Any trip circuitry associated with the “soft 86” would still need applicable verification activities performed, but the actual “86” does not have to be “electrically operated” or even toggled.

4. Definitions

Protection System Maintenance Program (PSMP) — An ongoing program by which Protection System, Automatic Reclosing and Sudden Pressure Relaying Components are kept in working order and proper operation of malfunctioning Components is restored. A maintenance program for a specific Component includes one or more of the following activities:

- Verify — Determine that the Component is functioning correctly.
- Monitor — Observe the routine in-service operation of the Component.
- Test — Apply signals to a Component to observe functional performance or output behavior, or to diagnose problems.
- Inspect — ~~Detect visible~~Examine for signs of Component failure, reduced performance and degradation.
- Calibrate — Adjust the operating threshold or measurement accuracy of a measuring element to meet the intended performance requirement.

Automatic Reclosing — Includes the following Components:

- Reclosing relay
- Supervisory relay(s) – relay(s) that perform voltage and/or sync check functions that enables or disables operation of the reclosing relay
- Voltage sensing devices associated with the supervisory relay(s)
- Control circuitry associated with the reclosing relay or supervisory relay(s).

Sudden Pressure Relaying — A system that trips an interrupting device(s) to isolate the equipment it is monitoring and includes the following Components:

- Fault pressure relay – a mechanical relay or device that detects rapid changes in gas pressure, oil pressure, or oil flow that are indicative of faults within liquid-filled, wire-wound equipment
- Control circuitry associated with a fault pressure relay

Unresolved Maintenance Issue — A deficiency identified during a maintenance activity that causes the component to not meet the intended performance, cannot be corrected during the maintenance interval, and requires follow-up corrective action.

Segment — Components of a consistent design standard, or a particular model or type from a single manufacturer that typically share other common elements. Consistent performance is expected across the entire population of a Segment. A Segment must contain at least sixty (60) individual Components.

Component Type —

- Any one of the five specific elements of a Protection System.
- Any one of the ~~two~~four specific elements of Automatic Reclosing.
- Any one of the two specific elements of Sudden Pressure Relaying.

Component – Any individual discrete piece of equipment included in a Protection System, Automatic Reclosing, or Sudden Pressure Relaying.

Countable Event – A failure of a Component requiring repair or replacement, any condition discovered during the maintenance activities in Tables 1-1 through 1-5, Table 3, Tables 4-1 through 4-3~~2~~, and Table 5, which requires corrective action or a Protection System Misoperation attributed to hardware failure or calibration failure. Misoperations due to product design errors, software errors, relay settings different from specified settings, Protection System Component, Automatic Reclosing or Sudden Pressure Relaying configuration or application errors are not included in Countable Events.

4.1 Frequently Asked Questions:

Why does PRC-005-4 not specifically require maintenance and testing procedures, as reflected in the previous standard, PRC-005-1?

PRC-005-1 does not require detailed maintenance and testing procedures, but instead requires summaries of such procedures, and is not clear on what is actually required. PRC-005-4 requires a documented maintenance program, and is focused on establishing requirements rather than prescribing methodology to meet those requirements. Between the activities identified in the Tables 1-1 through 1-5, Table 2, Table 3, and Table 4 (collectively the “Tables”), and the various components of the definition established for a “Protection System Maintenance Program,” PRC-005-4 establishes the activities and time basis for a Protection System Maintenance Program to a level of detail not previously required.

Please clarify what is meant by “restore” in the definition of maintenance.

The description of “restore” in the definition of a Protection System Maintenance Program addresses corrective activities necessary to assure that the component is returned to working order following the discovery of its failure or malfunction. The Maintenance Activities specified in the Tables do not present any requirements related to Restoration; R5 of the standard does require that the entity “shall demonstrate efforts to correct any identified Unresolved Maintenance Issues.” Some examples of restoration (or correction of Unresolved Maintenance Issues) include, but are not limited to, replacement of capacitors in distance relays to bring them to working order; replacement of relays, or other Protection System components, to bring the Protection System to working order; upgrade of electromechanical or solid-state protective relays to microprocessor-based relays following the discovery of failed components. Restoration, as used in this context, is not to be confused with restoration rules as used in system operations. Maintenance activity necessarily includes both the detection of problems and the repairs needed to eliminate those problems. This standard does not identify all of the Protection System problems that must be detected and eliminated, rather it is the intent of this standard that an entity determines the necessary working order for their various devices, and keeps them in working order. If an equipment item is repaired or replaced, then the entity can restart the maintenance-time-interval-clock, if desired; however, the replacement of equipment does not remove any documentation requirements that would have been required to verify compliance with time-interval requirements. In other words, do not discard maintenance data that goes to verify your work.

The retention of documentation for new and/or replaced equipment is all about proving that the maintenance intervals had been in compliance. For example, a long-range plan of upgrades

might lead an entity to ignore required maintenance; retaining the evidence of prior maintenance that existed before any retirements and upgrades proves compliance with the standard.

Please clarify what is meant by “...demonstrate efforts to correct an Unresolved Maintenance Issue...”; why not measure the completion of the corrective action?

Management of completion of the identified Unresolved Maintenance Issue is a complex topic that falls outside of the scope of this standard. There can be any number of supply, process and management problems that make setting repair deadlines impossible. The SDT specifically chose the phrase “demonstrate efforts to correct” (with guidance from NERC Staff) because of the concern that many more complex Unresolved Maintenance Issues might require greater than the remaining maintenance interval to resolve (and yet still be a “closed-end process”). For example, a problem might be identified on a VRLA battery during a six-month check. In instances such as one that requiring battery replacement as part of the long-term resolution, it is highly unlikely that the battery could be replaced in time to meet the six-calendar-month requirement for this maintenance activity. The SDT does not believe entities should be found in violation of a maintenance program requirement because of the inability to complete a remediation program within the original maintenance interval. The SDT does believe corrective actions should be timely, but concludes it would be impossible to postulate all possible remediation projects; and, therefore, impossible to specify bounding time frames for resolution of all possible Unresolved Maintenance Issues, or what documentation might be sufficient to provide proof that effective corrective action is being undertaken.

5. Time-Based Maintenance (TBM) Programs

Time-based maintenance is the process in which Protection System, Automatic Reclosing and Sudden Pressure Relaying Components are maintained or verified according to a time schedule. The scheduled program often calls for technicians to travel to the physical site and perform a functional test on Protection System components. However, some components of a TBM program may be conducted from a remote location - for example, tripping a circuit breaker by communicating a trip command to a microprocessor relay to determine if the entire Protection System tripping chain is able to operate the breaker. Similarly, all Protection System, and Sudden Pressure Relaying Components can have the ability to remotely conduct tests, either on-command or routinely; the running of these tests can extend the time interval between hands-on maintenance activities.

5.1 Maintenance Practices

Maintenance and testing programs often incorporate the following types of maintenance practices:

- TBM – time-based maintenance – externally prescribed maximum maintenance or testing intervals are applied for components or groups of components. The intervals may have been developed from prior experience or manufacturers’ recommendations. The TBM verification interval is based on a variety of factors, including experience of the particular asset owner, collective experiences of several asset owners who are members of a country or regional council, etc. The maintenance intervals are fixed and may range in number of months or in years.

TBM can include review of recent power system events near the particular terminal. Operating records may verify that some portion of the Protection System has operated correctly since the last test occurred. If specific protection scheme components have demonstrated correct performance within specifications, the maintenance test time clock can be reset for those components.

- PBM – Performance-Based Maintenance - intervals are established based on analytical or historical results of TBM failure rates on a statistically significant population of similar components. Some level of TBM is generally followed. Statistical analyses accompanied by adjustments to maintenance intervals are used to justify continued use of PBM-developed extended intervals when test failures or in-service failures occur infrequently.
- CBM – condition-based maintenance – continuously or frequently reported results from non-disruptive self-monitoring of components demonstrate operational status as those components remain in service. Whatever is verified by CBM does not require manual testing, but taking advantage of this requires precise technical focus on exactly what parts are included as part of the self-diagnostics. While the term “Condition-Based-Maintenance” (CBM) is no longer used within the standard itself, it is important to note that the concepts of CBM are a part of the standard (in the form of extended time intervals through status-monitoring). These extended time intervals are only allowed (in the absence of PBM) if the condition of the device is monitored (CBM). As a consequence of the “monitored-basis-time-intervals” existing within the standard, the explanatory

discussions within this Supplementary Reference concerned with CBM will remain in this reference and are discussed as CBM.

Microprocessor-based Protection System or Automatic Reclosing Components that perform continuous self-monitoring verify correct operation of most components within the device. Self-monitoring capabilities may include battery continuity, float voltages, unintentional grounds, the ac signal inputs to a relay, analog measuring circuits, processors and memory for measurement, protection, and data communications, trip circuit monitoring, and protection or data communications signals (and many, many more measurements). For those conditions, failure of a self-monitoring routine generates an alarm and may inhibit operation to avoid false trips. When internal components, such as critical output relay contacts, are not equipped with self-monitoring, they can be manually tested. The method of testing may be local or remote, or through inherent performance of the scheme during a system event.

The TBM is the overarching maintenance process of which the other types are subsets. Unlike TBM, PBM intervals are adjusted based on good or bad experiences. The CBM verification intervals can be hours, or even milliseconds between non-disruptive self-monitoring checks within or around components as they remain in service.

TBM, PBM, and CBM can be combined for individual components, or within a complete Protection System. The following diagram illustrates the relationship between various types of maintenance practices described in this section. In the Venn diagram, the overlapping regions show the relationship of TBM with PBM historical information and the inherent continuous monitoring offered through CBM.

This figure shows:

- Region 1: The TBM intervals that are increased based on known reported operational condition of individual components that are monitoring themselves.
- Region 2: The TBM intervals that are adjusted up or down based on results of analysis of maintenance history of statistically significant population of similar products that have been subject to TBM.
- Region 3: Optimal TBM intervals based on regions 1 and 2.

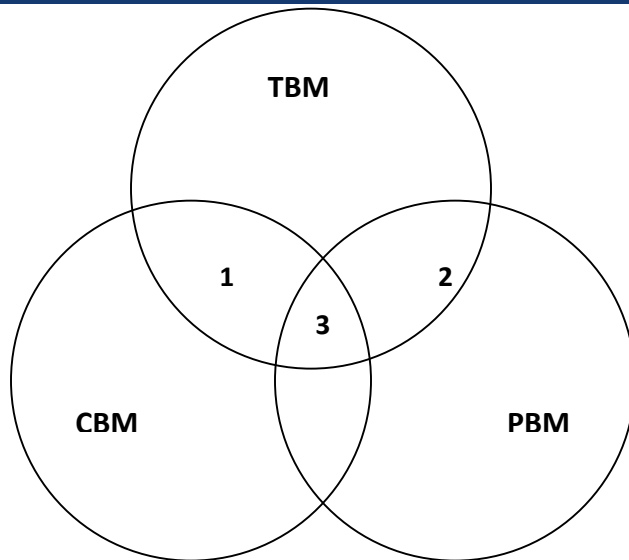

Relationship of time-based maintenance types

5.1.1 Frequently Asked Questions:

The standard seems very complicated, and is difficult to understand. Can it be simplified?

Because the standard is establishing parameters for condition-based Maintenance (R1) and Performance-Based Maintenance (R2), in addition to simple time-based Maintenance, it does appear to be complicated. At its simplest, an entity needs to **ONLY** perform time-based maintenance according to the unmonitored rows of the Tables. If an entity then wishes to take advantage of monitoring on its Protection System components and its available lengthened time intervals, then it may, as long as the component has the listed monitoring attributes. If an entity wishes to use historical performance of its Protection System components to perform Performance-Based Maintenance, then R2 applies.

Please see the following diagram, which provides a “flow chart” of the standard.

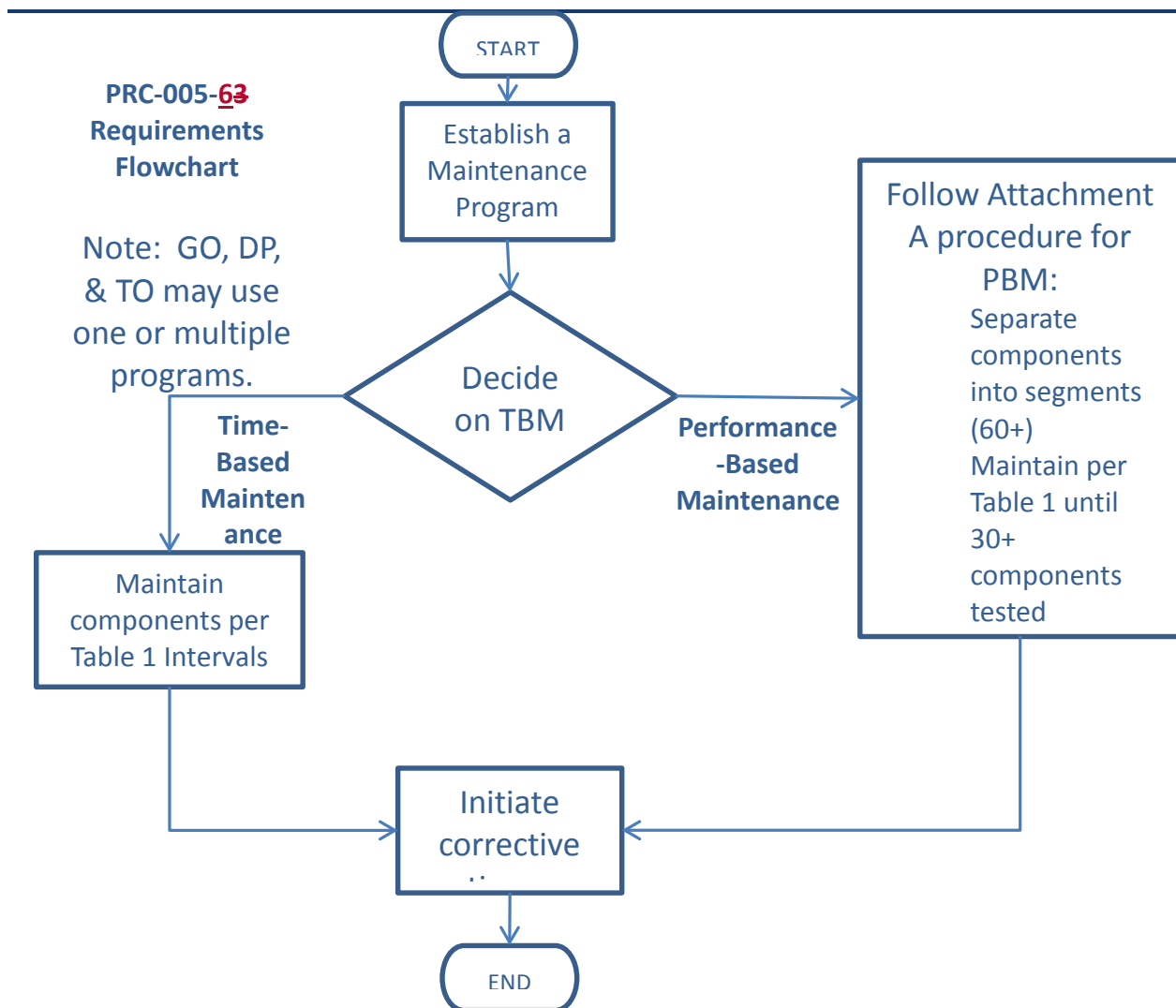

We have an electromechanical (unmonitored) relay that has a trip output to a lockout relay (unmonitored) which trips our transformer off-line by tripping the transformer's high-side and low-side circuit breakers. What testing must be done for this system?

This system is made up of components that are all unmonitored. Assuming a time-based Protection System Maintenance Program schedule (as opposed to a Performance-Based maintenance program), each component must be maintained per the most frequent hands-on activities listed in the Tables.

5.2 Extending Time-Based Maintenance

All maintenance is fundamentally time-based. Default time-based intervals are commonly established to assure proper functioning of each component of the Protection System, when data on the reliability of the components is not available other than observations from time-based maintenance. The following factors may influence the established default intervals:

- If continuous indication of the functional condition of a component is available (from relays or chargers or any self-monitoring device), then the intervals may be extended, or manual testing may be eliminated. This is referred to as condition-based maintenance or

CBM. CBM is valid only for precisely the components subject to monitoring. In the case of microprocessor-based relays, self-monitoring may not include automated diagnostics of every component within a microprocessor.

- Previous maintenance history for a group of components of a common type may indicate that the maintenance intervals can be extended, while still achieving the desired level of performance. This is referred to as Performance-Based Maintenance, or PBM. It is also sometimes referred to as reliability-centered maintenance, or RCM; but PBM is used in this document.
- Observed proper operation of a component may be regarded as a maintenance verification of the respective component or element in a microprocessor-based device. For such an observation, the maintenance interval may be reset only to the degree that can be verified by data available on the operation. For example, the trip of an electromechanical relay for a Fault verifies the trip contact and trip path, but only through the relays in series that actually operated; one operation of this relay cannot verify correct calibration.

Excessive maintenance can actually decrease the reliability of the component or system. It is not unusual to cause failure of a component by removing it from service and restoring it. The improper application of test signals may cause failure of a component. For example, in electromechanical overcurrent relays, test currents have been known to destroy convolution springs.

In addition, maintenance usually takes the component out of service, during which time it is not able to perform its function. Cutout switch failures, or failure to restore switch position, commonly lead to protection failures.

5.2.1 Frequently Asked Questions:

If I show the protective device out of service while it is being repaired, then can I add it back as a new protective device when it returns? If not, my relay testing history would show that I was out of compliance for the last maintenance cycle.

The maintenance and testing requirements (R5) (in essence) state "...shall demonstrate efforts to correct ~~any~~ identified Unresolved Maintenance Issues." The type of corrective activity is not stated; however it could include repairs or replacements.

Your documentation requirements will increase, of course, to demonstrate that your device tested bad and had corrective actions initiated. Your regional entity could very well ask for documentation showing status of your corrective actions.

6. Condition-Based Maintenance (CBM) Programs

Condition-based maintenance is the process of gathering and monitoring the information available from modern microprocessor-based relays and other intelligent electronic devices (IEDs) that monitor Protection System or Automatic Reclosing elements. These devices generate monitoring information during normal operation, and the information can be assessed at a convenient location remote from the substation. The information from these relays and IEDs is divided into two basic types:

1. Information can come from background self-monitoring processes, programmed by the manufacturer, or by the user in device logic settings. The results are presented by alarm contacts or points, front panel indications, and by data communications messages.
2. Information can come from event logs, captured files, and/or oscillographic records for Faults and Disturbances, metered values, and binary input status reports. Some of these are available on the device front panel display, but may be available via data communications ports. Large files of Fault information can only be retrieved via data communications. These results comprise a mass of data that must be further analyzed for evidence of the operational condition of the Protection System.

Using these two types of information, the user can develop an effective maintenance program carried out mostly from a central location remote from the substation. This approach offers the following advantages:

Non-invasive Maintenance: The system is kept in its normal operating state, without human intervention for checking. This reduces risk of damage, or risk of leaving the system in an inoperable state after a manual test. Experience has shown that keeping human hands away from equipment known to be working correctly enhances reliability.

Virtually Continuous Monitoring: CBM will report many hardware failure problems for repair within seconds or minutes of when they happen. This reduces the percentage of problems that are discovered through incorrect relaying performance. By contrast, a hardware failure discovered by TBM may have been there for much of the time interval between tests, and there is a good chance that some devices will show health problems by incorrect operation before being caught in the next test round. The frequent or continuous nature of CBM makes the effective verification interval far shorter than any required TBM maximum interval. To use the extended time intervals available through Condition Based Maintenance, simply look for the rows in the Tables that refer to monitored items.

6.1 Frequently Asked Questions:

My microprocessor relays and dc circuit alarms are contained on relay panels in a 24-hour attended control room. Does this qualify as an extended time interval condition-based (monitored) system?

Yes, provided the station attendant (plant operator, etc.) monitors the alarms and other indications (comparable to the monitoring attributes) and reports them within the given time limits that are stated in the criteria of the Tables.

When documenting the basis for inclusion of components into the appropriate levels of monitoring, as per Requirement R1 (Part 1.2) of the standard, is it necessary to provide this documentation about the device by listing of every component and the specific monitoring attributes of each device?

No. While maintaining this documentation on the device level would certainly be permissible, it is not necessary. Global statements can be made to document appropriate levels of monitoring for the entire population of a component type or portion thereof.

For example, it would be permissible to document the conclusion that all BES substation dc supply battery chargers are monitored by stating the following within the program description:

“All substation dc supply battery chargers are considered monitored and subject to the rows for monitored equipment of Table 1-4 requirements, as all substation dc supply battery chargers are equipped with dc voltage alarms and ground detection alarms that are sent to the manned control center.”

Similarly, it would be acceptable to use a combination of a global statement and a device-level list of exclusions. Example:

“Except as noted below, all substation dc supply battery chargers are considered monitored and subject to the rows for monitored equipment of Table 1-4 requirements, as all substation dc supply battery chargers are equipped with dc voltage alarms and ground detection alarms that are sent to the manned control center. The dc supply battery chargers of Substation X, Substation Y, and Substation Z are considered unmonitored and subject to the rows for unmonitored equipment in Table 1-4 requirements, as they are not equipped with ground detection capability.”

Regardless whether this documentation is provided by device listing of monitoring attributes, by global statements of the monitoring attributes of an entire population of component types, or by some combination of these methods, it should be noted that auditors may request supporting drawings or other documentation necessary to validate the inclusion of the device(s) within the appropriate level of monitoring. This supporting background information need not be maintained within the program document structure, but should be retrievable if requested by an auditor.

The applicability of R1.2 depends on the BES definition for Protection System to identify what components are to be covered by the Standard. One type of component is described as “Protective relays which respond to electrical quantities”. Would a protection function that is embedded in a Generator’s voltage regulator meet the BES definition for Protection System and thus be included in R1.2?

Yes. The fact that these functions are implemented by an excitation system or voltage regulator rather than a classical looking relay is immaterial. The devices monitor electrical parameters such as voltage and/or current and cause a trip of the generator in response to these signals. By implementing these functions in the excitation system, the excitation system has in essence become an elaborate form of a microprocessor relay.

The voltage regulator processes electrical quantities and has an output that trips the generator breaker, quite often through a lockout. Examples include voltage regulator electronic cards that monitor voltage for high V/Hz, high exciter field voltage or both. In older-generation regulators (1980s and 1990s) the protection functions are essentially electronic relays (not

electromechanical or microprocessor based but using transistors and potentiometers). Should either excess voltage condition be true, a contact mounted on the voltage regulator electronics board closes which, in turn, goes to an auxiliary relay or activates a lockout relay directly. The electronic quantities monitored include exciter field voltage, generator current, and generator terminal voltage.

7. Time-Based Versus Condition-Based Maintenance

Time-based and condition-based (or monitored) maintenance programs are both acceptable, if implemented according to technically sound requirements. Practical programs can employ a combination of time-based and condition-based maintenance. The standard requirements introduce the concept of optionally using condition monitoring as a documented element of a maintenance program.

The Federal Energy Regulatory Commission (FERC), in its Order Number 693 Final Rule, dated March 16, 2007 (18 CFR Part 40, Docket No. RM06-16-000) on Mandatory Reliability Standards for the Bulk-Power System, directed NERC to submit a modification to PRC-005-1b that includes a requirement that maintenance and testing of a Protection System must be carried out within a maximum allowable interval that is appropriate to the type of the Protection System and its impact on the reliability of the Bulk Power System. Accordingly, this Supplementary Reference Paper refers to the specific maximum allowable intervals in PRC-005-4. The defined time limits allow for longer time intervals if the maintained component is monitored.

A key feature of condition-based monitoring is that it effectively reduces the time delay between the moment of a protection failure and time the Protection System or Automatic Reclosing owner knows about it, for the monitored segments of the Protection System. In some cases, the verification is practically continuous - the time interval between verifications is minutes or seconds. Thus, technically sound, condition-based verification, meets the verification requirements of the FERC order even more effectively than the strictly time-based tests of the same system components.

The result is that:

This NERC standard permits utilities to use a technically sound approach and to take advantage of remote monitoring, data analysis, and control capabilities of modern Protection System and Automatic Reclosing Components to reduce the need for periodic site visits and invasive testing of components by on-site technicians. This periodic testing must be conducted within the maximum time intervals specified in the Tables of PRC-005-4.

7.1 Frequently Asked Questions:

What is a Calendar Year?

Calendar Year - January 1 through December 31 of any year. As an example, if an event occurred on June 17, 2009 and is on a "One Calendar Year Interval," the next event would have to occur on or before December 31, 2010.

Please provide an example of "4 Calendar Months".

If a maintenance activity is described as being needed every four Calendar Months then it is performed in a (given) month and due again four months later. For example a battery bank is inspected in month number 1 then it is due again before the end of the month number 5. And specifically consider that you perform your battery inspection on January 3, 2010 then it must be inspected again before the end of May. Another example could be that a four-month inspection was performed in January is due in May, but if performed in March (instead of May) would still

be due four months later therefore the activity is due again July. Basically every “four Calendar Months” means to add four months from the last time the activity was performed.

Please provide an example of the unmonitored versus other levels of monitoring available?

An unmonitored Protection System has no monitoring and alarm circuits on the Protection System components. A Protection System component that has monitoring attributes but no alarm output connected is considered to be unmonitored.

A monitored Protection System or an individual monitored component of a Protection System has monitoring and alarm circuits on the Protection System components. The alarm circuits must alert, within 24 hours, a location wherein corrective action can be initiated. This location might be, but is not limited to, an Operations Center, Dispatch Office, Maintenance Center or even a portable SCADA system.

There can be a combination of monitored and unmonitored Protection Systems within any given scheme, substation or plant; there can also be a combination of monitored and unmonitored components within any given Protection System.

Example #1: A combination of monitored and unmonitored components within a given Protection System might be:

- A microprocessor relay with an internal alarm connected to SCADA to alert 24-hr staffed operations center; it has internal self-diagnosis and alarming. (monitored)
- Instrumentation transformers, with no monitoring, connected as inputs to that relay. (unmonitored)
- A vented Lead-Acid battery with a low voltage alarm for the station dc supply voltage and an unintentional grounds detection alarm connected to SCADA. (monitoring varies)
- A circuit breaker with a trip coil, and the trip circuit is not monitored. (unmonitored)

Given the particular components and conditions, and using Table 1 and Table 2, the particular components have maximum activity intervals of:

Every four calendar months, inspect:

- Electrolyte level (station dc supply voltage and unintentional ground detection is being maintained more frequently by the monitoring system).

Every 18 calendar months, verify/inspect the following:

- Battery bank ohmic values to station battery baseline (if performance tests are not opted)
- Battery charger float voltage
- Battery rack integrity
- Cell condition of all individual battery cells (where visible)
- Battery continuity
- Battery terminal connection resistance

-
- Battery cell-to-cell resistance (where available to measure)

Every six calendar years, perform/verify the following:

- Battery performance test (if internal ohmic tests or other measurements indicative of battery performance are not opted)
- Verify that each trip coil is able to operate the circuit breaker, interrupting device, or mitigating device
- For electromechanical lock-out relays, electrical operation of electromechanical trip

Every 12 calendar years, verify the following:

- Microprocessor relay settings are as specified
- Operation of the microprocessor's relay inputs and outputs that are essential to proper functioning of the Protection System
- Acceptable measurement of power System input values seen by the microprocessor protective relay
- Verify that current and voltage signal values are provided to the protective relays
- Protection System component monitoring for the battery system signals are conveyed to a location where corrective action can be initiated
- The microprocessor relay alarm signals are conveyed to a location where corrective action can be initiated
- Verify all trip paths in the control circuitry associated with protective functions through the trip coil(s) of the circuit breakers or other interrupting devices
- Auxiliary outputs that are in the trip path shall be maintained as detailed in Table 1-5 of the standard under the 'Unmonitored Control Circuitry Associated with Protective Functions' section'
- Auxiliary outputs not in a trip path (i.e., annunciation or DME input) are not required, by this standard, to be checked

Example #2: A combination of monitored and unmonitored components within a given Protection System might be:

- A microprocessor relay with integral alarm that is not connected to SCADA. (unmonitored)
- Current and voltage signal values, with no monitoring, connected as inputs to that relay. (unmonitored)
- A vented lead-acid battery with a low voltage alarm for the station dc supply voltage and an unintentional grounds detection alarm connected to SCADA. (monitoring varies)
- A circuit breaker with a trip coil, with no circuits monitored. (unmonitored)

Given the particular components and conditions, and using the Table 1 (Maximum Allowable Testing Intervals and Maintenance Activities) and Table 2 (Alarming Paths and Monitoring), the particular components have maximum activity intervals of:

Every four calendar months, inspect:

-
- Electrolyte level (station dc supply voltage and unintentional ground detection is being maintained more frequently by the monitoring system)

Every 18 calendar months, verify/inspect the following:

- Battery bank trending of ohmic values or other measurements indicative of battery performance to station battery baseline (if performance tests are not opted)
- Battery charger float voltage
- Battery rack integrity
- Cell condition of all individual battery cells (where visible)
- Battery continuity
- Battery terminal connection resistance
- Battery cell-to-cell resistance (where available to measure)

Every six calendar years, verify/perform the following:

- Verify operation of the relay inputs and outputs that are essential to proper functioning of the Protection System
- Verify acceptable measurement of power system input values as seen by the relays
- Verify that each trip coil is able to operate the circuit breaker, interrupting device, or mitigating device
- For electromechanical lock-out relays, electrical operation of electromechanical trip
- Battery performance test (if internal ohmic tests are not opted)

Every 12 calendar years, verify the following:

- Current and voltage signal values are provided to the protective relays
- Protection System component monitoring for the battery system signals are conveyed to a location where corrective action can be initiated
- All trip paths in the control circuitry associated with protective functions through the trip coil(s) of the circuit breakers or other interrupting devices
- Auxiliary outputs that are in the trip path shall be maintained, as detailed in Table 1-5 of the standard under the Unmonitored Control Circuitry Associated with Protective Functions" section
- Auxiliary outputs not in a trip path (i.e., annunciation or DME input) are not required, by this standard, to be checked

Example #3: A combination of monitored and unmonitored components within a given Protection System might be:

- A microprocessor relay with alarm connected to SCADA to alert 24-hr staffed operations center; it has internal self-diagnosis and alarms. (monitored)

-
- Current and voltage signal values, with monitoring, connected as inputs to that relay (monitored)
 - Vented Lead-Acid battery without any alarms connected to SCADA (unmonitored)
 - Circuit breaker with a trip coil, with no circuits monitored (unmonitored)

Given the particular components, conditions, and using the Table 1 (Maximum Allowable Testing Intervals and Maintenance Activities) and Table 2 (Alarming Paths and Monitoring), the particular components shall have maximum activity intervals of:

Every four calendar months, verify/inspect the following:

- Station dc supply voltage
- For unintentional grounds
- Electrolyte level

Every 18 calendar months, verify/inspect the following:

- Battery bank trending of ohmic values or other measurements indicative of battery performance to station battery baseline (if performance tests are not opted)
- Battery charger float voltage
- Battery rack integrity
- Battery continuity
- Battery terminal connection resistance
- Battery cell-to-cell resistance (where available to measure)
- Condition of all individual battery cells (where visible)

Every six calendar years, perform/verify the following:

- Battery performance test (if internal ohmic tests or other measurements indicative of battery performance are not opted)
- Verify that each trip coil is able to operate the circuit breaker, interrupting device, or mitigating device
- For electromechanical lock-out relays, electrical operation of electromechanical trip

Every 12 calendar years, verify the following:

- The microprocessor relay alarm signals are conveyed to a location where corrective action can be taken
- Microprocessor relay settings are as specified
- Operation of the microprocessor's relay inputs and outputs that are essential to proper functioning of the Protection System
- Acceptable measurement of power system input values seen by the microprocessor protective relay
- Verify all trip paths in the control circuitry associated with protective functions through the trip coil(s) of the circuit breakers or other interrupting devices

-
- Auxiliary outputs that are in the trip path shall be maintained, as detailed in Table 1-5 of the standard under the Unmonitored Control Circuitry Associated with Protective Functions section
 - Auxiliary outputs not in a trip path (i.e. annunciation or DME input) are not required, by this standard, to be checked

Why do components have different maintenance activities and intervals if they are monitored?

The intent behind different activities and intervals for monitored equipment is to allow less frequent manual intervention when more information is known about the condition of Protection System components. Condition-Based Maintenance is a valuable asset to improve reliability.

Can all components in a Protection System be monitored?

No. For some components in a Protection System, monitoring will not be relevant. For example, a battery will always need some kind of inspection.

We have a 30-year-old oil circuit breaker with a red indicating lamp on the substation relay panel that is illuminated only if there is continuity through the breaker trip coil. There is no SCADA monitor or relay monitor of this trip coil. The line protection relay package that trips this circuit breaker is a microprocessor relay that has an integral alarm relay that will assert on a number of conditions that includes a loss of power to the relay. This alarm contact connects to our SCADA system and alerts our 24-hour operations center of relay trouble when the alarm contact closes. This microprocessor relay trips the circuit breaker only and does not monitor trip coil continuity or other things such as trip current. Are the components monitored or not? How often must I perform maintenance?

The protective relay is monitored and can be maintained every 12 years, or when an Unresolved Maintenance Issue arises. The control circuitry can be maintained every 12 years. The circuit breaker trip coil(s) has to be electrically operated at least once every six years.

What is a mitigating device?

A mitigating device is the device that acts to respond as directed by a Remedial Action Schemes. It may be a breaker, valve, distributed control system, or any variety of other devices. This response may include tripping, closing, or other control actions.

8. Maximum Allowable Verification Intervals

The maximum allowable testing intervals and maintenance activities show how CBM with newer device types can reduce the need for many of the tests and site visits that older Protection System components require. As explained below, there are some sections of the Protection System that monitoring or data analysis may not verify. Verifying these sections of the Protection System or Automatic Reclosing requires some persistent TBM activity in the maintenance program. However, some of this TBM can be carried out remotely - for example, exercising a circuit breaker through the relay tripping circuits using the relay remote control capabilities can be used to verify function of one tripping path and proper trip coil operation, if there has been no Fault or routine operation to demonstrate performance of relay tripping circuits.

8.1 Maintenance Tests

Periodic maintenance testing is performed to ensure that the protection and control system is operating correctly after a time period of field installation. These tests may be used to ensure that individual components are still operating within acceptable performance parameters - this type of test is needed for components susceptible to degraded or changing characteristics due to aging and wear. Full system performance tests may be used to confirm that the total Protection System functions from measurement of power system values, to properly identifying Fault characteristics, to the operation of the interrupting devices.

8.1.1 Table of Maximum Allowable Verification Intervals

Table 1 (collectively known as Table 1, individually called out as Tables 1-1 through 1-5), Table 2, Table 3, Table 4-1 through Table 4-~~32~~, and Table 5 in the standard specify maximum allowable verification intervals for various generations of Protection Systems, Automatic Reclosing and Sudden Pressure Relaying and categories of equipment that comprise these systems. The right column indicates maintenance activities required for each category.

The types of components are illustrated in [Figures 1](#) and 2 at the end of this paper. Figure 1 shows an example of telecommunications-assisted transmission Protection System comprising substation equipment at each terminal and a telecommunications channel for relaying between the two substations. [Figure 2](#) shows an example of a generation Protection System. The various sub-systems of a Protection System that need to be verified are shown.

Non-distributed UFLS, UVLS, and RAS are additional categories of Table 1 that are not illustrated in these figures. Non-distributed UFLS, UVLS and RAS all use identical equipment as Protection Systems in the performance of their functions; and, therefore, have the same maintenance needs.

Distributed UFLS and UVLS Systems, which use local sensing on the distribution System and trip co-located non-BES interrupting devices, are addressed in Table 3 with reduced maintenance activities.

While it is easy to associate protective relays to multiple levels of monitoring, it is also true that most of the components that can make up a Protection System can also have technological advancements that place them into higher levels of monitoring.

To use the Maintenance Activities and Intervals Tables from PRC-005-4:

-
- First find the Table associated with your component. The tables are arranged in the order of mention in the definition of Protection System;
 - Table 1-1 is for protective relays,
 - Table 1-2 is for the associated communications systems,
 - Table 1-3 is for current and voltage sensing devices,
 - Table 1-4 is for station dc supply and
 - Table 1-5 is for control circuits.
 - Table 2, is for alarms; this was broken out to simplify the other tables.
 - Table 3 is for components which make-up distributed UFLS and UVLS Systems.
 - Table 4 is for Automatic Reclosing.
 - Table 5 is for Sudden Pressure Relaying.
 - Next look within that table for your device and its degree of monitoring. The Tables have different hands-on maintenance activities prescribed depending upon the degree to which you monitor your equipment. Find the maintenance activity that applies to the monitoring level that you have on your piece of equipment.
 - This Maintenance activity is the minimum maintenance activity that must be documented.
 - If your Performance-Based Maintenance (PBM) plan requires more activities, then you must perform and document to this higher standard. (Note that this does not apply unless you utilize PBM.)
 - After the maintenance activity is known, check the maximum maintenance interval; this time is the maximum time allowed between hands-on maintenance activity cycles of this component.
 - If your Performance-Based Maintenance plan requires activities more often than the Tables maximum, then you must perform and document those activities to your more stringent standard. (Note that this does not apply unless you utilize PBM.)
 - Any given component of a Protection System can be determined to have a degree of monitoring that may be different from another component within that same Protection System. For example, in a given Protection System it is possible for an entity to have a monitored protective relay and an unmonitored associated communications system; this combination would require hands-on maintenance activity on the relay at least once every 12 years and attention paid to the communications system as often as every four months.
 - An entity does not have to utilize the extended time intervals made available by this use of condition-based monitoring. An easy choice to make is to simply utilize the unmonitored level of maintenance made available in each of the Tables. While the maintenance activities resulting from this choice would require more maintenance man-

hours, the maintenance requirements may be simpler to document and the resulting maintenance plans may be easier to create.

For each Protection System Component, Table 1 shows maximum allowable testing intervals for the various degrees of monitoring. For each Automatic Reclosing Component, Table 4 shows maximum allowable testing intervals for the various degrees of monitoring. These degrees of monitoring, or levels, range from the legacy unmonitored through a system that is more comprehensively monitored.

It has been noted here that an entity may have a PSMP that is more stringent than PRC-005-4. There may be any number of reasons that an entity chooses a more stringent plan than the minimums prescribed within PRC-005-4, most notable of which is an entity using performance based maintenance methodology.

If an entity has a Performance-Based Maintenance program, then that plan must be followed, even if the plan proves to be more stringent than the minimums laid out in the Tables.

If an entity has a Time-Based Maintenance program and the PSMP is more stringent than PRC-005-4, they will only be audited in accordance with the standard (minimum maintenance activities and maximum maintenance intervals prescribed within Tables 1-1 through 1-5, Table 2, Table 3, Table 4-1 through 4-~~32~~, and Table 5).

8.1.2 Additional Notes for Tables 1-1 through 1-5, Table 3, and Table 4

1. For electromechanical relays, adjustment is required to bring measurement accuracy within the tolerance needed by the asset owner. Microprocessor relays with no remote monitoring of alarm contacts, etc., are unmonitored relays and need to be verified within the Table interval as other unmonitored relays but may be verified as functional by means other than testing by simulated inputs.
2. Microprocessor relays typically are specified by manufacturers as not requiring calibration, but acceptable measurement of power system input values must be verified (verification of the Analog to Digital [A/D] converters) within the Table intervals. The integrity of the digital inputs and outputs that are used as protective functions must be verified within the Table intervals.
3. Any Phasor Measurement Unit (PMU) function whose output is used in a Protection System or RAS (as opposed to a monitoring task) must be verified as a component in a Protection System.
4. In addition to verifying the circuitry that supplies dc to the Protection System, the owner must maintain the station dc supply. The most widespread station dc supply is the station battery and charger. Unlike most Protection System components, physical inspection of station batteries for signs of component failure, reduced performance, and degradation are required to ensure that the station battery is reliable enough to deliver dc power when required. IEEE Standards 450, 1188, and 1106 for vented lead-acid, valve-regulated lead-acid, and nickel-cadmium batteries, respectively (which are the most commonly used substation batteries on the NERC BES) have been developed as an important reference source of maintenance recommendations. The Protection System owner might want to follow the guidelines in the applicable IEEE recommended practices for battery maintenance and testing, especially if the battery in question is used for application requirements in addition to the protection and control demands covered under this

standard. However, the Standard Drafting Team has tailored the battery maintenance and testing guidelines in PRC-005-4 for the Protection System owner which are application specific for the BES Facilities. While the IEEE recommendations are all encompassing, PRC-005-4 is a more economical approach while addressing the reliability requirements of the BES.

5. Aggregated small entities might distribute the testing of the population of UFLS/UVLS systems, and large entities will usually maintain a portion of these systems in any given year. Additionally, if relatively small quantities of such systems do not perform properly, it will not affect the integrity of the overall program. Thus, these distributed systems have decreased requirements as compared to other Protection Systems.
6. Voltage & current sensing device circuit input connections to the Protection System relays can be verified by (but not limited to) comparison of measured values on live circuits or by using test currents and voltages on equipment out of service for maintenance. The verification process can be automated or manual. The values should be verified to be as expected (phase value and phase relationships are both equally important to verify).
7. “End-to-end test,” as used in this Supplementary Reference, is any testing procedure that creates a remote input to the local communications-assisted trip scheme. While this can be interpreted as a GPS-type functional test, it is not limited to testing via GPS. Any remote scheme manipulation that can cause action at the local trip path can be used to functionally-test the dc control circuitry. A documented Real-time trip of any given trip path is acceptable in lieu of a functional trip test. It is possible, with sufficient monitoring, to be able to verify each and every parallel trip path that participated in any given dc control circuit trip. Or another possible solution is that a single trip path from a single monitored relay can be verified to be the trip path that successfully tripped during a Real-time operation. The variations are only limited by the degree of engineering and monitoring that an entity desires to pursue.
8. A/D verification may use relay front panel value displays, or values gathered via data communications. Groupings of other measurements (such as vector summation of bus feeder currents) can be used for comparison if calibration requirements assure acceptable measurement of power system input values.
9. Notes 1-8 attempt to describe some testing activities; they do not represent the only methods to achieve these activities, but rather some possible methods. Technological advances, ingenuity and/or industry accepted techniques can all be used to satisfy maintenance activity requirements; the standard is technology- and method-neutral in most cases.

8.1.3 Frequently Asked Questions:

What is meant by “Verify that settings are as specified” maintenance activity in Table 1-1?

Verification of settings is an activity directed mostly towards microprocessor- based relays. For relay maintenance departments that choose to test microprocessor-based relays in the same manner as electromechanical relays are tested, the testing process sometimes requires that some specific functions be disabled. Later tests might enable the functions previously

disabled, but perhaps still other functions or logic statements were then masked out. It is imperative that, when the relay is placed into service, the settings in the relay be the settings that were intended to be in that relay or as the standard states “...settings are as specified.”

Many of the microprocessor- based relays available today have software tools which provide this functionality and generate reports for this purpose.

For evidence or documentation of this requirement, a simple recorded acknowledgement that the settings were checked to be as specified is sufficient.

The drafting team was careful not to require “...that the relay settings be correct...” because it was believed that this might then place a burden of proof that the specified settings would result in the correct intended operation of the interrupting device. While that is a noble intention, the measurable proof of such a requirement is immense. The intent is that settings of the component be as specified at the conclusion of maintenance activities, whether those settings may have “drifted” since the prior maintenance or whether changes were made as part of the testing process.

Are electromechanical relays included in the “Verify that settings are as specified” maintenance activity in Table 1-1?

Verification of settings is an activity directed towards the application of protection related functions of microprocessor based relays. Electromechanical relays require calibration verification by voltage and/or current injection; and, thus, the settings are verified during calibration activity. In the example of a time-overcurrent relay, a minor deviation in time dial, versus the settings, may be acceptable, as long as the relay calibration is within accepted tolerances at the injected current amplitudes. A major deviation may require further investigation, as it could indicate a problem with the relay or an incorrect relay style for the application.

The verification of phase current and voltage measurements by comparison to other quantities seems reasonable. How, though, can I verify residual or neutral currents, or 3V0 voltages, by comparison, when my system is closely balanced?

Since these inputs are verified at commissioning, maintenance verification requires ensuring that phase quantities are as expected and that 3IO and 3V0 quantities appear equal to or close to 0.

These quantities also may be verified by use of oscillographic records for connected microprocessor relays as recorded during system Disturbances. Such records may compare to similar values recorded at other locations by other microprocessor relays for the same event, or compared to expected values (from short circuit studies) for known Fault locations.

What does this Standard require for testing an auxiliary tripping relay?

Table 1 and Table 3 requires that a trip test must verify that the auxiliary tripping relay(s) and/or lockout relay(s) which are directly in a trip path from the protective relay to the interrupting device trip coil operate(s) electrically. Auxiliary outputs not in a trip path (i.e. annunciation or DME input) are not required, by this standard, to be checked.

Do I have to perform a full end-to-end test of a Remedial Action schemes?

No. All portions of the -RAS need to be maintained, and the portions must overlap, but the overall RAS does not need to have a single end-to-end test. In other words it may be tested in piecemeal fashion provided all of the pieces are verified.

What about RAS interfaces between different entities or owners?

As in all of the Protection System requirements, RAS segments can be tested individually, thus minimizing the need to accommodate complex maintenance schedules.

What do I have to do if I am using a phasor measurement unit (PMU) as part of a Protection System or Remedial Action Schemes?

Any Phasor Measurement Unit (PMU) function whose output is used in a Protection System or Remedial Action Schemes (as opposed to a monitoring task) must be verified as a component in a Protection System.

How do I maintain a Remedial Action Schemes or relay sensing for non-distributed UFLS or UVLS Systems?

Since components of the RAS, UFLS and UVLS are the same types of components as those in Protection Systems, then these components should be maintained like similar components used for other Protection System functions. In many cases the devices for RAS, UFLS and UVLS are also used for other protective functions. The same maintenance activities apply with the exception that distributed systems (UFLS and UVLS) have fewer dc supply and control circuitry maintenance activity requirements.

For the testing of the output action, verification may be by breaker tripping, but may be verified in overlapping segments. For example, an RAS that trips a remote circuit breaker might be tested by testing the various parts of the scheme in overlapping segments. Another method is to document the Real-time tripping of an RAS scheme should that occur. Forced trip tests of circuit breakers (etc.) that are a part of distributed UFLS or UVLS schemes are not required.

The established maximum allowable intervals do not align well with the scheduled outages for my power plant. Can I extend the maintenance to the next scheduled outage following the established maximum interval?

No. You must complete your maintenance within the established maximum allowable intervals in order to be compliant. You will need to schedule your maintenance during available outages to complete your maintenance as required, even if it means that you may do protective relay maintenance more frequently than the maximum allowable intervals. The maintenance intervals were selected with typical plant outages, among other things, in mind.

If I am unable to complete the maintenance, as required, due to a major natural disaster (hurricane, earthquake, etc.), how will this affect my compliance with this standard?

The Sanction Guidelines of the North American Electric Reliability Corporation, effective January 15, 2008, provides that the Compliance Monitor will consider extenuating circumstances when considering any sanctions.

What if my observed testing results show a high incidence of out-of-tolerance relays; or, even worse, I am experiencing numerous relay Misoperations due to the relays being out-of-tolerance?

The established maximum time intervals are mandatory only as a not-to-exceed limitation. The establishment of a maximum is measurable. But any entity can choose to test some or all of their Protection System components more frequently (or to express it differently, exceed the minimum requirements of the standard). Particularly if you find that the maximum intervals in the standard do not achieve your expected level of performance, it is understandable that you would maintain the related equipment more frequently. A high incidence of relay Misoperations is in no one's best interest.

We believe that the four-month interval between inspections is unnecessary. Why can we not perform these inspections twice per year?

The Standard Drafting Team, through the comment process, has discovered that routine monthly inspections are not the norm. To align routine station inspections with other important inspections, the four-month interval was chosen. In lieu of station visits, many activities can be accomplished with automated monitoring and alarming.

Our maintenance plan calls for us to perform routine protective relay tests every 3 years. If we are unable to achieve this schedule, but we are able to complete the procedures in less than the maximum time interval, then are we in or out of compliance?

According to R3, if you have a time-based maintenance program, then you will be in violation of the standard only if you exceed the maximum maintenance intervals prescribed in the Tables. According to R4, if your device in question is part of a Performance-Based Maintenance program, then you will be in violation of the standard if you fail to meet your PSMP, even if you do not exceed the maximum maintenance intervals prescribed in the Tables. The intervals in the Tables are associated with TBM and CBM; Attachment A is associated with PBM.

Please provide a sample list of devices or systems that must be verified in a generator, generator step-up transformer, generator connected station service or generator connected excitation transformer to meet the requirements of this maintenance standard.

Examples of typical devices and systems that may directly trip the generator, or trip through a lockout relay, may include, but are not necessarily limited to:

- Fault protective functions, including distance functions, voltage-restrained overcurrent functions, or voltage-controlled overcurrent functions
- Loss-of-field relays
- Volts-per-hertz relays
- Negative sequence overcurrent relays
- Over voltage and under voltage protection relays
- Stator-ground relays
- Communications-based Protection Systems such as transfer-trip systems
- Generator differential relays
- Reverse power relays
- Frequency relays

-
- Out-of-step relays
 - Inadvertent energization protection
 - Breaker failure protection

For generator step-up, generator-connected station service transformers, or generator connected excitation transformers, operation of any of the following associated protective relays frequently would result in a trip of the generating unit; and, as such, would be included in the program:

- Transformer differential relays
- Neutral overcurrent relay
- Phase overcurrent relays

Relays which trip breakers serving station auxiliary Loads such as pumps, fans, or fuel handling equipment, etc., need not be included in the program, even if the loss of the those Loads could result in a trip of the generating unit. Furthermore, relays which provide protection to secondary unit substation (SUS) or low switchgear transformers and relays protecting other downstream plant electrical distribution system components are not included in the scope of this program, even if a trip of these devices might eventually result in a trip of the generating unit. For example, a thermal overcurrent trip on the motor of a coal-conveyor belt could eventually lead to the tripping of the generator, but it does not cause the trip.

In the case where a plant does not have a generator connected station service transformer such that it is normally fed from a system connected station service transformer, is it still the drafting team's intent to exclude the Protection Systems for these system connected auxiliary transformers from scope even when the loss of the normal (system connected) station service transformer will result in a trip of a BES generating Facility?

The SDT does not intend that the system-connected station service transformers be included in the Applicability. The generator-connected station service transformers and generator connected excitation transformers are often connected to the generator bus directly without an interposing breaker; thus, the Protection Systems on these transformers will trip the generator as discussed in 4.2.5.1.

What is meant by "verify operation of the relay inputs and outputs that are essential to proper functioning of the Protection System?"

Any input or output (of the relay) that "affects the tripping" of the breaker is included in the scope of I/O of the relay to be verified. By "affects the tripping," one needs to realize that sometimes there are more inputs and outputs than simply the output to the trip coil. Many important protective functions include things like breaker fail initiation, zone timer initiation and sometimes even 52a/b contact inputs are needed for a protective relay to correctly operate.

Each input should be "picked up" or "turned on and off" and verified as changing state by the microprocessor of the relay. Each output should be "operated" or "closed and opened" from the microprocessor of the relay and the output should be verified to change state on the output

terminals of the relay. One possible method of testing inputs of these relays is to “jumper” the needed dc voltage to the input and verify that the relay registered the change of state.

Electromechanical lock-out relays (86) (used to convey the tripping current to the trip coils) need to be electrically operated to prove the capability of the device to change state. These tests need to be accomplished at least every six years, unless PBM methodology is applied.

The contacts on the 86 or auxiliary tripping relays (94) that change state to pass on the trip current to a breaker trip coil need only be checked every 12 years with the control circuitry.

What is the difference between a distributed UFLS/UVLS and a non-distributed UFLS/UVLS scheme?

A distributed UFLS or UVLS scheme contains individual relays which make independent Load shed decisions based on applied settings and localized voltage and/or current inputs. A distributed scheme may involve an enable/disable contact in the scheme and still be considered a distributed scheme. A non-distributed UFLS or UVLS scheme involves a system where there is some type of centralized measurement and Load shed decision being made. A non-distributed UFLS/UVLS scheme is considered similar to an RAS scheme and falls under Table 1 for maintenance activities and intervals.

8.2 Retention of Records

PRC-005-1 describes a reporting or auditing cycle of one year and retention of records for three years. However, with a three-year retention cycle, the records of verification for a Protection System might be discarded before the next verification, leaving no record of what was done if a Misoperation or failure is to be analyzed.

PRC-005-4 corrects this by requiring:

The Transmission Owner, Generator Owner, and Distribution Provider shall each keep data or evidence to show compliance as identified below unless directed by its Compliance Enforcement Authority to retain specific evidence for a longer period of time as part of an investigation.

For Requirement R1, the Transmission Owner, Generator Owner, and Distribution Provider shall each keep its current dated Protection System Maintenance Program, as well as any superseded versions since the preceding compliance audit, including the documentation that specifies the type of maintenance program applied for each Protection System, Automatic Reclosing, or Sudden Pressure Relaying Component Type.

For Requirement R2, Requirement R3, and Requirement R4, in cases where the interval of the maintenance activity is longer than the audit cycle, the Transmission Owner, Generator Owner, and Distribution Provider shall each keep documentation of the most recent performance of that maintenance activity for the Protection System, Automatic Reclosing, or Sudden Pressure Relaying Component. In cases where the interval of the maintenance activity is shorter than the audit cycle, documentation of all performances (in accordance with the tables) of that maintenance activity for the Protection System, Automatic Reclosing, or Sudden Pressure Relaying Component since the previous scheduled audit date shall be retained.

For Requirement R5 the Transmission Owner, Generator Owner, and Distribution Provider shall each keep documentation of Unresolved Maintenance Issues identified by the entity since the last audit, including all that were resolved since the last audit.

This requirement assures that the documentation shows that the interval between maintenance cycles correctly meets the maintenance interval limits. The requirement is actually alerting the industry to documentation requirements already implemented by audit teams. Evidence of compliance bookending the interval shows interval accomplished instead of proving only your planned interval.

The SDT is aware that, in some cases, the retention period could be relatively long. But, the retention of documents simply helps to demonstrate compliance.

8.2.1 Frequently Asked Questions:

Please clarify the data retention requirements.

The data retention requirements are intended to allow the availability of maintenance records to demonstrate that the time intervals in your maintenance plan were upheld.

<u>Maximum Maintenance Interval</u>	<u>Data Retention Period</u>
4 Months, 6 Months, 18 Months, or 3 Years	All activities since previous audit
6 Years	All activities since previous audit (assuming a 6 year audit cycle) or most recent performance (assuming 3 year audit cycle), whichever is longer
12 Year	All activities from the most recent performance

If an entity prefers to utilize Performance-Based Maintenance, then statistical data may well be retained for extended periods to assist with future adjustments in time intervals.

If an equipment item is replaced, then the entity can restart the maintenance-time-interval-clock if desired; however, the replacement of equipment does not remove any documentation requirements that would have been required to verify compliance with time-interval requirements. In other words, do not discard maintenance data that goes to verify your work.

The retention of documentation for new and/or replaced equipment is all about proving that the maintenance intervals had been in compliance. For example, a long-range plan of upgrades might lead an entity to ignore required maintenance; retaining the evidence of prior maintenance that existed before any retirements and upgrades proves compliance with the standard.

What does this Maintenance Standard say about commissioning? Is it necessary to have documentation in your maintenance history of the completion of commission testing?

This standard does not establish requirements for commission testing. Commission testing includes all testing activities necessary to conclude that a Facility has been built in accordance with design. While a thorough commission testing program would include, either directly or indirectly, the verification of all those Protection System attributes addressed by the

maintenance activities specified in the Tables of PRC-005-4, verification of the adequacy of initial installation necessitates the performance of testing and inspections that go well beyond these routine maintenance activities. For example, commission testing might set baselines for future tests; perform acceptance tests and/or warranty tests; utilize testing methods that are not generally done routinely like staged-Fault-tests.

However, many of the Protection System attributes which are verified during commission testing are not subject to age related or service related degradation, and need not be re-verified within an ongoing maintenance program. Example – it is not necessary to re-verify correct terminal strip wiring on an ongoing basis.

PRC-005-4 assumes that thorough commission testing was performed prior to a Protection System being placed in service. PRC-005-4 requires performance of maintenance activities that are deemed necessary to detect and correct plausible age and service related degradation of components, such that a properly built and commission tested Protection System will continue to function as designed over its service life.

It should be noted that commission testing frequently is performed by a different organization than that which is responsible for the ongoing maintenance of the Protection System. Furthermore, the commission testing activities will not necessarily correlate directly with the maintenance activities required by the standard. As such, it is very likely that commission testing records will deviate significantly from maintenance records in both form and content; and, therefore, it is not necessary to maintain commission testing records within the maintenance program documentation.

Notwithstanding the differences in records, an entity would be wise to retain commissioning records to show a maintenance start date. (See below). An entity that requires that their commissioning tests have, at a minimum, the requirements of PRC-005-4 would help that entity prove time interval maximums by setting the initial time clock.

How do you determine the initial due date for maintenance?

The initial due date for maintenance should be based upon when a Protection System was tested. Alternatively, an entity may choose to use the date of completion of the commission testing of the Protection System component and the system was placed into service as the starting point in determining its first maintenance due dates. Whichever method is chosen, for newly installed Protection Systems the components should not be placed into service until minimum maintenance activities have taken place.

It is conceivable that there can be a (substantial) difference in time between the date of testing, as compared to the date placed into service. The use of the “Calendar Year” language can help determine the next due date without too much concern about being non-compliant for missing test dates by a small amount (provided your dates are not already at the end of a year). However, if there is a substantial amount of time difference between testing and in-service dates, then the testing date should be followed because it is the degradation of components that is the concern. While accuracy fluctuations may decrease when components are not energized, there are cases when degradation can take place, even though the device is not energized. Minimizing the time between commissioning tests and in-service dates will help.

If I miss two battery inspections four times out of 100 Protection System components on my transmission system, does that count as 2% or 8% when counting Violation Severity Level (VSL) for R3?

The entity failed to complete its scheduled program on two of its 100 Protection System components, which would equate to 2% for application to the VSL Table for Requirement R3. This VSL is written to compare missed components to total components. In this case two components out of 100 were missed, or 2%.

How do I achieve a “grace period” without being out of compliance?

The objective here is to create a time extension within your own PSMP that still does not violate the maximum time intervals stated in the standard. Remember that the maximum time intervals listed in the Tables cannot be extended.

For the purposes of this example, concentrating on just unmonitored protective relays – Table 1-1 specifies a maximum time interval (between the mandated maintenance activities) of six calendar years. Your plan must ensure that your unmonitored relays are tested at least once every six calendar years. You could, within your PSMP, require that your unmonitored relays be tested every four calendar years, with a maximum allowable time extension of 18 calendar months. This allows an entity to have deadlines set for the auto-generation of work orders, but still has the flexibility in scheduling complex work schedules. This also allows for that 18 calendar months to act as a buffer, in effect a grace period within your PSMP, in the event of unforeseen events. You will note that this example of a maintenance plan interval has a planned time of four years; it also has a built-in time extension allowed within the PSMP, and yet does not exceed the maximum time interval allowed by the standard. So while there are no time extensions allowed beyond the standard, an entity can still have substantial flexibility to maintain their Protection System components.

8.3 Basis for Table 1 Intervals

When developing the original *Protection System Maintenance – A Technical Reference* in 2007, the SPCTF collected all available data from Regional Entities (REs) on time intervals recommended for maintenance and test programs. The recommendations vary widely in categorization of relays, defined maintenance actions, and time intervals, precluding development of intervals by averaging. The SPCTF also reviewed the 2005 Report [2] of the IEEE Power System Relaying Committee Working Group I-17 (Transmission Relay System Performance Comparison). Review of the I-17 report shows data from a small number of utilities, with no company identification or means of investigating the significance of particular results.

To develop a solid current base of practice, the SPCTF surveyed its members regarding their maintenance intervals for electromechanical and microprocessor relays, and asked the members to also provide definitively-known data for other entities. The survey represented 470 GW of peak Load, or 4% of the NERC peak Load. Maintenance interval averages were compiled by weighting reported intervals according to the size (based on peak Load) of the reporting utility. Thus, the averages more accurately represent practices for the large populations of Protection Systems used across the NERC regions.

The results of this survey with weighted averaging indicate maintenance intervals of five years for electromechanical or solid state relays, and seven years for unmonitored microprocessor relays.

A number of utilities have extended maintenance intervals for microprocessor relays beyond seven years, based on favorable experience with the particular products they have installed. To

provide a technical basis for such extension, the SPCTF authors developed a recommendation of 10 years using the Markov modeling approach from [1], as summarized in Section 8.4. The results of this modeling depend on the completeness of self-testing or monitoring. Accordingly, this extended interval is allowed by Table 1, only when such relays are monitored as specified in the attributes of monitoring contained in Tables 1-1 through 1-5 and Table 2. Monitoring is capable of reporting Protection System health issues that are likely to affect performance within the 10 year time interval between verifications.

It is important to note that, according to modeling results, Protection System availability barely changes as the maintenance interval is varied below the 10-year mark. Thus, reducing the maintenance interval does not improve Protection System availability. With the assumptions of the model regarding how maintenance is carried out, reducing the maintenance interval actually degrades Protection System availability.

8.4 Basis for Extended Maintenance Intervals for Microprocessor Relays

Table 1 allows maximum verification intervals that are extended based on monitoring level. The industry has experience with self-monitoring microprocessor relays that leads to the Table 1 value for a monitored relay, as explained in Section 8.3. To develop a basis for the maximum interval for monitored relays in their *Protection System Maintenance – A Technical Reference*, the SPCTF used the methodology of Reference [1], which specifically addresses optimum routine maintenance intervals. The Markov modeling approach of [1] is judged to be valid for the design and typical failure modes of microprocessor relays.

The SPCTF authors ran test cases of the Markov model to calculate two key probability measures:

- Relay Unavailability - the probability that the relay is out of service due to failure or maintenance activity while the power system Element to be protected is in service.
- Abnormal Unavailability - the probability that the relay is out of service due to failure or maintenance activity when a Fault occurs, leading to failure to operate for the Fault.

The parameter in the Markov model that defines self-monitoring capability is ST (for self-test). ST = 0 if there is no self-monitoring; ST = 1 for full monitoring. Practical ST values are estimated to range from .75 to .95. The SPCTF simulation runs used constants in the Markov model that were the same as those used in [1] with the following exceptions:

Sn, Normal tripping operations per hour = 21600 (reciprocal of normal Fault clearing time of 10 cycles)

Sb, Backup tripping operations per hour = 4320 (reciprocal of backup Fault clearing time of 50 cycles)

Rc, Protected component repairs per hour = 0.125 (8 hours to restore the power system)

Rt, Relay routine tests per hour = 0.125 (8 hours to test a Protection System)

Rr, Relay repairs per hour = 0.08333 (12 hours to complete a Protection System repair after failure)

Experimental runs of the model showed low sensitivity of optimum maintenance interval to these parameter adjustments.

The resulting curves for relay unavailability and abnormal unavailability versus maintenance interval showed a broad minimum (optimum maintenance interval) in the vicinity of 10 years –

the curve is flat, with no significant change in either unavailability value over the range of 9, 10, or 11 years. This was true even for a relay mean time between Failures (MTBF) of 50 years, much lower than MTBF values typically published for these relays. Also, the Markov modeling indicates that both the relay unavailability and abnormal unavailability actually become higher with more frequent testing. This shows that the time spent on these more frequent tests yields no failure discoveries that approach the negative impact of removing the relays from service and running the tests.

The PSMT SDT discussed the practical need for “time-interval extensions” or “grace periods” to allow for scheduling problems that resulted from any number of business contingencies. The time interval discussions also focused on the need to reflect industry norms surrounding Generator outage frequencies. Finally, it was again noted that FERC Order 693 demanded maximum time intervals. “Maximum time intervals” by their very term negates any “time-interval extension” or “grace periods.” To recognize the need to follow industry norms on Generator outage frequencies and accommodate a form of time-interval extension, while still following FERC Order 693, the Standard Drafting Team arrived at a six-year interval for the electromechanical relay, instead of the five-year interval arrived at by the SPCTF. The PSMT SDT has followed the FERC directive for a *maximum* time interval and has determined that no extensions will be allowed. Six years has been set for the maximum time interval between manual maintenance activities. This maximum time interval also works well for maintenance cycles that have been in use in generator plants for decades.

For monitored relays, the PSMT SDT notes that the SPCTF called for 10 years as the interval between maintenance activities. This 10-year interval was chosen, even though there was “...no significant change in unavailability value over the range of 9, 10, or 11 years. This was true even for a relay Mean Time between Failures (MTBF) of 50 years...” The Standard Drafting Team again sought to align maintenance activities with known successful practices and outage schedules. The Standard does not allow extensions on any component of the Protection System; thus, the maximum allowed interval for these components has been set to 12 years. Twelve years also fits well into the traditional maintenance cycles of both substations and generator plants.

Also of note is the Table’s use of the term “Calendar” in the column for “Maximum Maintenance Interval.” The PSMT SDT deemed it necessary to include the term “Calendar” to facilitate annual maintenance planning, scheduling and implementation. This need is the result of known occurrences of system requirements that could cause maintenance schedules to be missed by a few days or weeks. The PSMT SDT chose the term “Calendar” to preclude the need to have schedules be met to the day. An electromechanical protective relay that is maintained in year number one need not be revisited until six years later (year number seven). For example, a relay was maintained April 10, 2008; maintenance would need to be completed no later than December 31, 2014.

Though not a requirement of this standard, to stay in line with many Compliance Enforcement Agencies audit processes an entity should define, within their own PSMP, the entity’s use of terms like annual, calendar year, etc. Then, once this is within the PSMP, the entity should abide by their chosen language.

9. Performance-Based Maintenance Process

In lieu of using the Table 1 intervals, a Performance-Based Maintenance process may be used to establish maintenance intervals (*PRC-005 Attachment A Criteria for a Performance-Based Protection System Maintenance Program*). A Performance-Based Maintenance process may justify longer maintenance intervals, or require shorter intervals relative to Table 1. In order to use a Performance-Based Maintenance process, the documented maintenance program must include records of repairs, adjustments, and corrections to covered Protection Systems in order to provide historical justification for intervals, other than those established in Table 1. Furthermore, the asset owner must regularly analyze these records of corrective actions to develop a ranking of causes. Recurrent problems are to be highlighted, and remedial action plans are to be documented to mitigate or eliminate recurrent problems.

Entities with Performance-Based Maintenance track performance of Protection Systems, demonstrate how they analyze findings of performance failures and aberrations, and implement continuous improvement actions. Since no maintenance program can ever guarantee that no malfunction can possibly occur, documentation of a Performance-Based Maintenance program would serve the utility well in explaining to regulators and the public a Misoperation leading to a major System outage event.

A Performance-Based Maintenance program requires auditing processes like those included in widely used industrial quality systems (such as *ISO 9001-2000, Quality Management Systems – Requirements*; or applicable parts of the NIST Baldrige National Quality Program). The audits periodically evaluate:

- The completeness of the documented maintenance process
- Organizational knowledge of and adherence to the process
- Performance metrics and documentation of results
- Remediation of issues
- Demonstration of continuous improvement.

In order to opt into a Performance-Based Maintenance (PBM) program, the asset owner must first sort the various Components into population segments. Any population segment must be comprised of at least 60 individual units; if any asset owner opts for PBM, but does not own 60 units to comprise a population, then that asset owner may combine data from other asset owners until the needed 60 units is aggregated. Each population segment must be composed of a grouping of Components of a consistent design standard or particular model or type from a single manufacturer and subjected to similar environmental factors. For example: One segment cannot be comprised of both GE & Westinghouse electro-mechanical lock-out relays; likewise, one segment cannot be comprised of 60 GE lock-out relays, 30 of which are in a dirty environment, and the remaining 30 from a clean environment. This PBM process cannot be applied to batteries, but can be applied to all other Components, including (but not limited to) specific battery chargers, instrument transformers, trip coils and/or control circuitry (etc.).

9.1 Minimum Sample Size

Large Sample Size

An assumption that needs to be made when choosing a sample size is “the sampling distribution of the sample mean can be approximated by a normal probability distribution.” The Central Limit Theorem states: “In selecting simple random samples of size n from a population, the sampling distribution of the sample mean \bar{x} can be approximated by a normal probability distribution as the sample size becomes large.” (Essentials of Statistics for Business and Economics, Anderson, Sweeney, Williams, 2003.)

To use the Central Limit Theorem in statistics, the population size should be large. The references below are supplied to help define what is large.

“... whenever we are using a large simple random sample (rule of thumb: $n \geq 30$), the central limit theorem enables us to conclude that the sampling distribution of the sample mean can be approximated by a normal distribution.” (Essentials of Statistics for Business and Economics, Anderson, Sweeney, Williams, 2003.)

“If samples of size n , when $n \geq 30$, are drawn from any population with a mean μ and a standard deviation σ , the sampling distribution of sample means approximates a normal distribution. The greater the sample size, the better the approximation.” (Elementary Statistics - Picturing the World, Larson, Farber, 2003.)

“The sample size is large (generally $n \geq 30$)... (Introduction to Statistics and Data Analysis - Second Edition, Peck, Olson, Devore, 2005.)

“... the normal is often used as an approximation to the t distribution in a test of a null hypothesis about the mean of a normally distributed population when the population variance is estimated from a relatively large sample. A sample size exceeding 30 is often given as a minimal size in this connection.” (Statistical Analysis for Business Decisions, Peters, Summers, 1968.)

Error of Distribution Formula

Beyond the large sample size discussion above, a sample size requirement can be estimated using the bound on the Error of Distribution Formula when the expected result is of a “Pass/Fail” format and will be between 0 and 1.0.

The Error of Distribution Formula is:

$$B = z \sqrt{\frac{\pi(1-\pi)}{n}}$$

Where:

B = bound on the error of distribution (allowable error)

z = standard error

π = expected failure rate

n = sample size required

Solving for n provides:

$$n = \pi(1 - \pi) \left(\frac{z}{B} \right)^2$$

Minimum Population Size to use Performance-Based Program

One entity's population of components should be large enough to represent a sizeable sample of a vendor's overall population of manufactured devices. For this reason, the following assumptions are made:

$$B = 5\%$$

$$z = 1.96 \text{ (This equates to a 95\% confidence level)}$$

$$\pi = 4\%$$

Using the equation above, n=59.0.

Minimum Sample Size to evaluate Performance-Based Program

The number of components that should be included in a sample size for evaluation of the appropriate testing interval can be smaller because a lower confidence level is acceptable since the sample testing is repeated or updated annually. For this reason, the following assumptions are made:

$$B = 5\%$$

$$z = 1.44 \text{ (85\% confidence level)}$$

$$\pi = 4\%$$

Using the equation above, n=31.8.

Recommendation

Based on the above discussion, a sample size should be at least 30 to allow use of the equation mentioned. Using this and the results of the equation, the following numbers are recommended (and required within the standard):

Minimum Population Size to use Performance-Based Maintenance Program = 60

Minimum Sample Size to evaluate Performance-Based Program = 30.

Once the population segment is defined, then maintenance must begin within the intervals as outlined for the device described in the Tables 1-1 through 1-5. Time intervals can be lengthened provided the last year's worth of components tested (or the last 30 units maintained, whichever is more) had fewer than 4% Countable Events. It is notable that 4% is specifically chosen because an entity with a small population (30 units) would have to adjust its time intervals between maintenance if more than one Countable Event was found to have occurred during the last analysis period. A smaller percentage would require that entity to adjust the time interval between maintenance activities if even one unit is found out of tolerance or causes a Misoperation.

The minimum number of units that can be tested in any given year is 5% of the population. Note that this 5% threshold sets a practical limitation on total length of time between intervals at 20 years.

If at any time the number of Countable Events equals or exceeds 4% of the last year's tested components (or the last 30 units maintained, whichever is more), then the time period between manual maintenance activities must be decreased. There is a time limit on reaching the decreased time at which the Countable Events is less than 4%; this must be attained within three years.

Performance-Based Program Evaluation Example

The 4% performance target was derived as a protection system performance target and was selected based on the drafting team's experience and studies performed by several utilities. This is not derived from the performance of discrete devices. Microprocessor relays and electromechanical relays have different performance levels. It is not appropriate to compare these performance levels to each other. The performance of the segment should be compared to the 4% performance criteria.

In consideration of the use of Performance Based Maintenance (PBM), the user should consider the effects of extended testing intervals and the established 4% failure rate. In the table shown below, the segment is 1000 units. As the testing interval (in years) increases, the number of units tested each year decreases. The number of countable events allowed is 4% of the tested units. Countable events are the failure of a Component requiring repair or replacement, any corrective actions performed during the maintenance test on the units within the testing segment (units per year), or any misoperation attributable to hardware failure or calibration failure found within the entire segment (1000 units) during the testing year.

Example: 1000 units in the segment with a testing interval of 8 years: The number of units tested each year will be 125 units. The total allowable countable events equals: $125 \times .04 = 5$. This number includes failure of a Component requiring repair or replacement, corrective issues found during testing, and the total number of misoperations (attributable to hardware or calibration failure within the testing year) associated with the entire segment of 1000 units.

Example: 1000 units in the segment with a testing interval of 16 years: The number of units tested each year will be 63 units. The total allowable countable events equals: $63 \times .04 = 2.5$.

As shown in the above examples, doubling the testing interval reduces the number of allowable events by half.

Total number of units in the segment	1000
Failure rate	4.00%

Testing Intervals (Years)	Units Per Year	Acceptable Number of Countable Events per year	Yearly Failure Rate Based on 1000 Units in Segment
1	1000.00	40.00	4.00%
2	500.00	20.00	2.00%
4	250.00	10.00	1.00%
6	166.67	6.67	0.67%
8	125.00	5.00	0.50%
10	100.00	4.00	0.40%
12	83.33	3.33	0.33%
14	71.43	2.86	0.29%
16	62.50	2.50	0.25%
18	55.56	2.22	0.22%
20	50.00	2.00	0.20%

Using the prior year’s data, determine the maximum allowable maintenance interval for each Segment such that the Segment experiences Countable Events on no more than 4% of the Components within the Segment, for the greater of either the last 30 Components maintained or all Components maintained in the previous year.

Segment – Components of a consistent design standard, or a particular model or type from a single manufacturer that typically share other common elements. Consistent performance is expected across the entire population of a Segment. A Segment must contain at least sixty (60) individual Components.

Countable Event – A failure of a Component requiring repair or replacement, any condition discovered during the maintenance activities in Tables 1-1 through 1-5, Table 3, Table 4-1 through Table 4-~~32~~, and Table 5, which requires corrective action or a Protection System Misoperation attributed to hardware failure or calibration failure. Misoperations due to product design errors, software errors, relay settings different from specified settings, Protection System Component, Automatic Reclosing, or Sudden Pressure Relaying configuration or application errors are not included in Countable Events.

9.2 Frequently Asked Questions:

I’m a small entity and cannot aggregate a population of Protection System components to establish a segment required for a Performance-Based Protection System Maintenance Program. How can I utilize that opportunity?

Multiple asset owning entities may aggregate their individually owned populations of individual Protection System components to create a segment that crosses ownership boundaries. All entities participating in a joint program should have a single documented joint management process, with consistent Protection System Maintenance Programs (practices, maintenance

intervals and criteria), for which the multiple owners are individually responsible with respect to the requirements of the Standard. The requirements established for Performance-Based Maintenance must be met for the overall aggregated program on an ongoing basis.

The aggregated population should reflect all factors that affect consistent performance across the population, including any relevant environmental factors such as geography, power-plant vs. substation, and weather conditions.

Can an owner go straight to a Performance-Based Maintenance program schedule, if they have previously gathered records?

Yes. An owner can go to a Performance-Based Maintenance program immediately. The owner will need to comply with the requirements of a Performance-Based Maintenance program as listed in the Standard. Gaps in the data collected will not be allowed; therefore, if an owner finds that a gap exists such that they cannot prove that they have collected the data as required for a Performance-Based Maintenance program then they will need to wait until they can prove compliance.

When establishing a Performance-Based Maintenance program, can I use test data from the device manufacturer, or industry survey results, as results to help establish a basis for my Performance-Based intervals?

No, you must use actual in-service test data for the components in the segment.

What types of Misoperations or events are not considered Countable Events in the Performance-Based Protection System Maintenance (PBM) Program?

Countable Events are intended to address conditions that are attributed to hardware failure or calibration failure; that is, conditions that reflect deteriorating performance of the component. These conditions include any condition where the device previously worked properly, then, due to changes within the device, malfunctioned or degraded to the point that re-calibration (to within the entity's tolerance) was required.

For this purpose of tracking hardware issues, human errors resulting in Protection System Misoperations during system installation or maintenance activities are not considered Countable Events. Examples of excluded human errors include relay setting errors, design errors, wiring errors, inadvertent tripping of devices during testing or installation, and misapplication of Protection System components. Examples of misapplication of Protection System components include wrong CT or PT tap position, protective relay function misapplication, and components not specified correctly for their installation. Obviously, if one is setting up relevant data about hardware failures then human failures should be eliminated from the hardware performance analysis.

One example of human-error is not pertinent data might be in the area of testing "86" lock-out relays (LOR). "Entity A" has two types of LOR's type "X" and type "Y"; they want to move into a performance based maintenance interval. They have 1000 of each type, so the population variables are met. During electrical trip testing of all of their various schemes over the initial six-year interval they find zero type "X" failures, but human error led to tripping a BES Element 100 times; they find 100 type "Y" failures and had an additional 100 human-error caused tripping incidents. In this example the human-error caused Misoperations should not be used to judge the performance of either type of LOR. Analysis of the data might lead "Entity A" to change time intervals. Type "X" LOR can be placed into extended time interval testing because of its low failure

rate (zero failures) while Type “Y” would have to be tested more often than every 6 calendar years (100 failures divided by 1000 units exceeds the 4% tolerance level).

Certain types of Protection System component errors that cause Misoperations are not considered Countable Events. Examples of excluded component errors include device malfunctions that are correctable by firmware upgrades and design errors that do not impact protection function.

What are some examples of methods of correcting segment performance for Performance-Based Maintenance?

There are a number of methods that may be useful for correcting segment performance for mal-performing segments in a Performance-Based Maintenance system. Some examples are listed below.

- The maximum allowable interval, as established by the Performance-Based Maintenance system, can be decreased. This may, however, be slow to correct the performance of the segment.
- Identifiable sub-groups of components within the established segment, which have been identified to be the mal-performing portion of the segment, can be broken out as an independent segment for target action. Each resulting segment must satisfy the minimum population requirements for a Performance-Based Maintenance program in order to remain within the program.
- Targeted corrective actions can be taken to correct frequently occurring problems. An example would be replacement of capacitors within electromechanical distance relays if bad capacitors were determined to be the cause of the mal-performance.
- components within the mal-performing segment can be replaced with other components (electromechanical distance relays with microprocessor relays, for example) to remove the mal-performing segment.

If I find (and correct) a Unresolved Maintenance Issue as a result of a Misoperation investigation (Re: PRC-004), how does this affect my Performance-Based Maintenance program?

If you perform maintenance on a Protection System component for any reason (including as part of a PRC-004 required Misoperation investigation/corrective action), the actions performed can count as a maintenance activity provided the activities in the relevant Tables have been done, and, if you desire, “reset the clock” on everything you’ve done. In a Performance-Based Maintenance program, you also need to record the Unresolved Maintenance Issue as a Countable Event within the relevant component group segment and use it in the analysis to determine your correct Performance-Based Maintenance interval for that component group. Note that “resetting the clock” should not be construed as interfering with an entity’s routine testing schedule because the “clock-reset” would actually make for a decreased time interval by the time the next routine test schedule comes around.

For example a relay scheme, consisting of four relays, is tested on 1-1-11 and the PSMP has a time interval of 3 calendar years with an allowable extension of 1 calendar year. The relay would be due again for routine testing before the end of the year 2015. This mythical relay scheme has a Misoperation on 6-1-12 that points to one of the four relays as bad. Investigation proves a bad relay and a new one is tested and installed in place of the original. This replacement relay actually

could be retested before the end of the year 2016 (clock-reset) and not be out of compliance. This requires tracking maintenance by individual relays and is allowed. However, many companies schedule maintenance in other ways like by substation or by circuit breaker or by relay scheme. By these methods of tracking maintenance that “replaced relay” will be retested before the end of the year 2015. This is also acceptable. In no case was a particular relay tested beyond the PSMP of four years max, nor was the 6 year max of the Standard exceeded. The entity can reset the clock if they desire or the entity can continue with original schedules and, in effect, test even more frequently.

Why are batteries excluded from PBM? What about exclusion of batteries from condition based maintenance?

Batteries are the only element of a Protection System that is a perishable item with a shelf life. As a perishable item batteries require not only a constant float charge to maintain their freshness (charge), but periodic inspection to determine if there are problems associated with their aging process and testing to see if they are maintaining a charge or can still deliver their rated output as required.

Besides being perishable, a second unique feature of a battery that is unlike any other Protection System element is that a battery uses chemicals, metal alloys, plastics, welds, and bonds that must interact with each other to produce the constant dc source required for Protection Systems, undisturbed by ac system Disturbances.

No type of battery manufactured today for Protection System application is free from problems that can only be detected over time by inspection and test. These problems can arise from variances in the manufacturing process, chemicals and alloys used in the construction of the individual cells, quality of welds and bonds to connect the components, the plastics used to make batteries and the cell forming process for the individual battery cells.

Other problems that require periodic inspection and testing can result from transportation from the factory to the job site, length of time before a charge is put on the battery, the method of installation, the voltage level and duration of equalize charges, the float voltage level used, and the environment that the battery is installed in.

All of the above mentioned factors and several more not discussed here are beyond the control of the Functional Entities that want to use a Performance-Based Protection System Maintenance (PBM) program. These inherent variances in the aging process of a battery cell make establishment of a designated segment based on manufacturer and type of battery impossible.

The whole point of PBM is that if all variables are isolated then common aging and performance criteria would be the same. However, there are too many variables in the electrochemical process to completely isolate all of the performance-changing criteria.

Similarly, Functional Entities that want to establish a condition-based maintenance program using the highest levels of monitoring, resulting in the least amount of hands-on maintenance activity, cannot completely eliminate some periodic maintenance of the battery used in a station dc supply. Inspection of the battery is required on a Maximum Maintenance Interval listed in the tables due to the aging processes of station batteries. However, higher degrees of

monitoring of a battery can eliminate the requirement for some periodic testing and some inspections (see Table 1-4).

Please provide an example of the calculations involved in extending maintenance time intervals using PBM.

Entity has 1000 GE-HEA lock-out relays; this is greater than the minimum sample requirement of 60. They start out testing all of the relays within the prescribed Table requirements (6 year max) by testing the relays every 5 years. The entity's plan is to test 200 units per year; this is greater than the minimum sample size requirement of 30. For the sake of example only the following will show 6 failures per year, reality may well have different numbers of failures every year. PBM requires annual assessment of failures found per units tested. After the first year of tests the entity finds 6 failures in the 200 units tested. $6/200 = 3\%$ failure rate. This entity is now allowed to extend the maintenance interval if they choose. The entity chooses to extend the maintenance interval of this population segment out to 10 years. This represents a rate of 100 units tested per year; entity selects 100 units to be tested in the following year. After that year of testing these 100 units the entity again finds 6 failed units. $6/100 = 6\%$ failures. This entity has now exceeded the acceptable failure rate for these devices and must accelerate testing of all of the units at a higher rate such that the failure rate is found to be less than 4% per year; the entity has three years to get this failure rate down to 4% or less (per year). In response to the 6% failure rate, the entity decreases the testing interval to 8 years. This means that they will now test 125 units per year ($1000/8$). The entity has just two years left to get the test rate corrected.

After a year, they again find six failures out of the 125 units tested. $6/125 = 5\%$ failures. In response to the 5% failure rate, the entity decreases the testing interval to seven years. This means that they will now test 143 units per year ($1000/7$). The entity has just one year left to get the test rate corrected. After a year, they again find six failures out of the 143 units tested. $6/143 = 4.2\%$ failures.

(Note that the entity has tried five years and they were under the 4% limit and they tried seven years and they were over the 4% limit. They must be back at 4% failures or less in the next year so they might simply elect to go back to five years.)

Instead, in response to the 5% failure rate, the entity decreases the testing interval to six years. This means that they will now test 167 units per year ($1000/6$). After a year, they again find six failures out of the 167 units tested. $6/167 = 3.6\%$ failures. Entity found that they could maintain the failure rate at no more than 4% failures by maintaining the testing interval at six years or less. Entity chose six-year interval and effectively extended their TBM (five years) program by 20%.

A note of practicality is that an entity will probably be in better shape to lengthen the intervals between tests if the failure rate is less than 2%. But the requirements allow for annual adjustments, if the entity desires. As a matter of maintenance management, an ever-changing test rate (units tested/year) may be un-workable.

Note that the "5% of components" requirement effectively sets a practical limit of 20 year maximum PBM interval. Also of note is the "3 years" requirement; an entity might arbitrarily extend time intervals from six years to 20 years. In the event that an entity finds a failure rate greater than 4%, then the test rate must be accelerated such that within three years the failure rate must be brought back down to 4% or less.

Here is a table that demonstrates the values discussed:

Year #	Total Population (P)	Test Interval (I)	Units to be Tested (U= P/I)	# of Failures Found (F)	Failure Rate (=F/U)	Decision to Change Interval Yes or No	Interval Chosen
1	1000	5 yrs	200	6	3%	Yes	10 yrs
2	1000	10 yrs	100	6	6%	Yes	8 yrs
3	1000	8 yrs	125	6	5%	Yes	7 yrs
4	1000	7 yrs	143	6	4.2%	Yes	6 yrs
5	1000	6 yrs	167	6	3.6%	No	6 yrs

Please provide an example of the calculations involved in extending maintenance time intervals using PBM for control circuitry.

Note that the following example captures “Control Circuitry” as all of the trip paths associated with a particular trip coil of a circuit breaker. An entity is not restricted to this method of counting control circuits. Perhaps another method an entity would prefer would be to simply track every individual (parallel) trip path. Or perhaps another method would be to track all of the trip outputs from a specific (set) of relays protecting a specific element.

The designation of what constitutes a control circuit component is very dependent upon how an entity performs and tracks the testing of the control circuitry. Some entities test their control circuits on a breaker basis whereas others test their circuitry on a local zone of protection basis. Thus, entities are allowed the latitude to designate their own definitions of control circuit components. Another example of where the entity has some discretion on determining what constitutes a single component is the voltage and current sensing devices, where the entity may choose either to designate a full three-phase set of such devices or a single device as a single component.

And in Attachment A (PBM) the definition of Segment:

Segment –*Components of a consistent design standard, or a particular model or type from a single manufacturer that typically share other common elements. Consistent performance is expected across the entire population of a segment. A segment must contain at least sixty (60) individual components.*

Example:

Entity has 1,000 circuit breakers, all of which have two trip coils, for a total of 2,000 trip coils; if all circuitry was designed and built with a consistent (internal entity) standard, then this is greater than the minimum sample requirement of 60.

For the sake of further example, the following facts are given:

Half of all relay panels (500) were built 40 years ago by an outside contractor, consisted of asbestos wrapped 600V-insulation panel wiring, and the cables exiting the control house are THHN pulled in conduit direct to exactly half of all of the various circuit breakers. All of the relay panels and cable pulls were built with consistent standards and consistent performance standard expectations within the segment (which is greater than 60). Each relay panel has redundant microprocessor (MPC) relays (retrofitted); each MPC relay supplies an individual trip output to each of the two trip coils of the assigned circuit breaker.

Approximately 35 years ago, the entity developed their own internal construction crew and now builds all of their own relay panels from parts supplied from vendors that meet the entity’s specifications, including SIS 600V insulation wiring and copper-sheathed cabling within the direct conduits to circuit breakers. The construction crew uses consistent standards in the construction. This newer segment of their control circuitry population is different than the original segment, consistent (standards, construction and performance expectations) within the new segment and constitutes the remainder of the entity’s population (another 500 panels and the cabling to the remaining 500 circuit breakers). Each relay panel has redundant microprocessor (MPC) relays; each MPC relay supplies an individual trip output to each of the two trip coils of the assigned circuit breaker. Every trip path in this newer segment has a device that monitors the voltage directly across the trip contacts of the MPC relays and alarms via RTU and SCADA to the

operations control room. This monitoring device, when not in alarm, demonstrates continuity all the way through the trip coil, cabling and wiring back to the trip contacts of the MPC relay.

The entity is tracking 2,000 trip coils (each consisting of multiple trip paths) in each of these two segments. But half of all of the trip paths are monitored; therefore, the trip paths are continuously tested and the circuit will alarm when there is a failure. These alarms have to be verified every 12 years for correct operation.

The entity now has 1,000 trip coils (and associated trip paths) remaining that they have elected to count as control circuits. The entity has instituted a process that requires the verification of every trip path to each trip coil (one unit), including the electrical activation of the trip coil. (The entity notes that the trip coils will have to be tripped electrically more often than the trip path verification, and is taking care of this activity through other documentation of Real-time Fault operations.)

They start out testing all of the trip coil circuits within the prescribed Table requirements (12-year max) by testing the trip circuits every 10 years. The entity's plan is to test 100 units per year; this is greater than the minimum sample size requirement of 30. For the sake of example only, the following will show three failures per year; reality may well have different numbers of failures every year. PBM requires annual assessment of failures found per units tested. After the first year of tests, the entity finds three failures in the 100 units tested. $3/100 = 3\%$ failure rate.

This entity is now allowed to extend the maintenance interval, if they choose. The entity chooses to extend the maintenance interval of this population segment out to 20 years. This represents a rate of 50 units tested per year; entity selects 50 units to be tested in the following year. After that year of testing these 50 units, the entity again finds three failed units. $3/50 = 6\%$ failures.

This entity has now exceeded the acceptable failure rate for these devices and must accelerate testing of all of the units at a higher rate, such that the failure rate is found to be less than 4% per year; the entity has three years to get this failure rate down to 4% or less (per year).

In response to the 6% failure rate, the entity decreases the testing interval to 16 years. This means that they will now test 63 units per year ($1000/16$). The entity has just two years left to get the test rate corrected. After a year, they again find three failures out of the 63 units tested. $3/63 = 4.76\%$ failures.

In response to the >4% failure rate, the entity decreases the testing interval to 14 years. This means that they will now test 72 units per year ($1000/14$). The entity has just one year left to get the test rate corrected. After a year, they again find three failures out of the 72 units tested. $3/72 = 4.2\%$ failures.

(Note that the entity has tried 10 years, and they were under the 4% limit; and they tried 14 years, and they were over the 4% limit. They must be back at 4% failures or less in the next year, so they might simply elect to go back to 10 years.)

Instead, in response to the 4.2% failure rate, the entity decreases the testing interval to 12 years. This means that they will now test 84 units per year ($1000/12$). After a year, they again find three failures out of the 84 units tested. $3/84 = 3.6\%$ failures.

Entity found that they could maintain the failure rate at no more than 4% failures by maintaining the testing interval at 12 years or less. Entity chose 12-year interval, and effectively extended their TBM (10 years) program by 20%.

A note of practicality is that an entity will probably be in better shape to lengthen the intervals between tests if the failure rate is less than 2%. But the requirements allow for annual adjustments if the entity desires. As a matter of maintenance management, an ever-changing test rate (units tested / year) may be un-workable.

Note that the “5% of components” requirement effectively sets a practical limit of 20-year maximum PBM interval. Also of note is the “3 years” requirement; an entity might arbitrarily extend time intervals from six years to 20 years. In the event that an entity finds a failure rate greater than 4%, then the test rate must be accelerated such that within three years the failure rate must be brought back down to 4% or less.

Here is a table that demonstrates the values discussed:

Year #	Total Population (P)	Test Interval (I)	Units to be Tested (U= P/I)	# of Failures Found (F)	Failure Rate (=F/U)	Decision to Change Interval Yes or No	Interval Chosen
1	1000	10 yrs	100	3	3%	Yes	20 yrs
2	1000	20 yrs	50	3	6%	Yes	16yrs
3	1000	16 yrs	63	3	4.8%	Yes	14 yrs
4	1000	14 yrs	72	3	4.2%	Yes	12 yrs
5	1000	12 yrs	84	3	3.6%	No	12 yrs

Please provide an example of the calculations involved in extending maintenance time intervals using PBM for voltage and current sensing devices.

Note that the following example captures “voltage and current inputs to the protective relays” as all of the various current transformer and potential transformer signals associated with a particular set of relays used for protection of a specific Element. This entity calls this set of protective relays a “Relay Scheme.” Thus, this entity chooses to count PT and CT signals as a group instead of individually tracking maintenance activities to specific bushing CT’s or specific PT’s. An entity is not restricted to this method of counting voltage and current devices, signals and paths. Perhaps another method an entity would prefer would be to simply track every individual PT and CT. Note that a generation maintenance group may well select the latter because they may elect to perform routine off-line tests during generator outages, whereas a transmission maintenance group might create a process that utilizes Real-time system values measured at the relays.

The designation of what constitutes a control circuit component is very dependent upon how an entity performs and tracks the testing of the control circuitry. Some entities test their control circuits on a breaker basis whereas others test their circuitry on a local zone of protection basis. Thus, entities are allowed the latitude to designate their own definitions of control circuit components. Another example of where the entity has some discretion on determining what constitutes a single component is the voltage and current sensing devices, where the entity may choose either to designate a full three-phase set of such devices or a single device as a single component.

And in Attachment A (PBM) the definition of Segment:

Segment –*Components of a consistent design standard, or a particular model or type from a single manufacturer that typically share other common elements. Consistent performance is expected across the entire population of a segment. A segment must contain at least sixty (60) individual components.*

Example:

Entity has 2000 “Relay Schemes,” all of which have three current signals supplied from bushing CTs, and three voltage signals supplied from substation bus PT’s. All cabling and circuitry was designed and built with a consistent (internal entity) standard, and this population is greater than the minimum sample requirement of 60.

For the sake of further example the following facts are given:

Half of all relay schemes (1,000) are supplied with current signals from ANSI STD C800 bushing CTs and voltage signals from PTs built by ACME Electric MFR CO. All of the relay panels and cable pulls were built with consistent standards, and consistent performance standard expectations exist for the consistent wiring, cabling and instrument transformers within the segment (which is greater than 60).

The other half of the entity’s relay schemes have MPC relays with additional monitoring built-in that compare DNP values of voltages and currents (or Watts and VARs), as interpreted by the MPC relays and alarm for an entity-accepted tolerance level of accuracy. This newer segment of their “Voltage and Current Sensing” population is different than the original segment, consistent

(standards, construction and performance expectations) within the new segment and constitutes the remainder of the entity's population.

The entity is tracking many thousands of voltage and current signals within 2,000 relay schemes (each consisting of multiple voltage and current signals) in each of these two segments. But half of all of the relay schemes voltage and current signals are monitored; therefore, the voltage and current signals are continuously tested and the circuit will alarm when there is a failure; these alarms have to be verified every 12 years for correct operation.

The entity now has 1,000 relay schemes worth of voltage and current signals remaining that they have elected to count within their relay schemes designation. The entity has instituted a process that requires the verification of these voltage and current signals within each relay scheme (one unit).

(Please note - a problem discovered with a current or voltage signal found at the relay could be caused by anything from the relay, all the way to the signal source itself. Having many sources of problems can easily increase failure rates beyond the rate of failures of just one item (for example just PTs). It is the intent of the SDT to minimize failure rates of all of the equipment to an acceptable level; thus, any failure of any item that gets the signal from source to relay is counted. It is for this reason that the SDT chose to set the boundary at the ability of the signal to be delivered all the way to the relay.

The entity will start out measuring all of the relay scheme voltage and currents at the individual relays within the prescribed Table requirements (12 year max) by measuring the voltage and current values every 10 years. The entity's plan is to test 100 units per year; this is greater than the minimum sample size requirement of 30. For the sake of example only, the following will show three failures per year; reality may well have different numbers of failures every year. PBM requires annual assessment of failures found per units tested. After the first year of tests, the entity finds three failures in the 100 units tested. $3/100 = 3\%$ failure rate.

This entity is now allowed to extend the maintenance interval, if they choose. The entity chooses to extend the maintenance interval of this population segment out to 20 years. This represents a rate of 50 units tested per year; entity selects 50 units to be tested in the following year. After that year of testing these 50 units, the entity again finds three failed units. $3/50 = 6\%$ failures.

This entity has now exceeded the acceptable failure rate for these devices and must accelerate testing of all of the units at a higher rate, such that the failure rate is found to be less than 4% per year; the entity has three years to get this failure rate down to 4% or less (per year).

In response to the 6% failure rate, the entity decreases the testing interval to 16 years. This means that they will now test 63 units per year ($1000/16$). The entity has just two years left to get the test rate corrected. After a year, they again find three failures out of the 63 units tested. $3/63 = 4.76\%$ failures.

In response to the >4% failure rate, the entity decreases the testing interval to 14 years. This means that they will now test 72 units per year ($1000/14$). The entity has just one year left to get the test rate corrected. After a year, they again find three failures out of the 72 units tested. $3/72 = 4.2\%$ failures.

(Note that the entity has tried 10 years, and they were under the 4% limit; and they tried 14 years, and they were over the 4% limit. They must be back at 4% failures or less in the next year, so they might simply elect to go back to 10 years.)

Instead, in response to the 4.2% failure rate, the entity decreases the testing interval to 12 years. This means that they will now test 84 units per year (1,000/12). After a year, they again find three failures out of the 84 units tested. $3/84 = 3.6\%$ failures.

Entity found that they could maintain the failure rate at no more than 4% failures by maintaining the testing interval at 12 years or less. Entity chose 12-year interval and effectively extended their TBM (10 years) program by 20%.

A note of practicality is that an entity will probably be in better shape to lengthen the intervals between tests if the failure rate is less than 2%. But the requirements allow for annual adjustments, if the entity desires. As a matter of maintenance management, an ever-changing test rate (units tested/year) may be un-workable.

Note that the “5% of components” requirement effectively sets a practical limit of 20-year maximum PBM interval. Also of note is the “3 years” requirement; an entity might arbitrarily extend time intervals from six years to 20 years. In the event that an entity finds a failure rate greater than 4%, then the test rate must be accelerated such that within three years the failure rate must be brought back down to 4% or less.

Here is a table that demonstrates the values discussed:

Year #	Total Population (P)	Test Interval (I)	Units to be Tested (U= P/I)	# of Failures Found (F)	Failure Rate (=F/U)	Decision to Change Interval Yes or No	Interval Chose
1	1000	10 yrs	100	3	3%	Yes	20 yrs
2	1000	20 yrs	50	3	6%	Yes	16yrs
3	1000	16 yrs	63	3	4.8%	Yes	14 yrs
4	1000	14 yrs	72	3	4.2%	Yes	12 yrs
5	1000	12 yrs	84	3	3.6%	No	12 yrs

10. Overlapping the Verification of Sections of the Protection System

Tables 1-1 through 1-5 require that every Protection System component be periodically verified. One approach, but not the only method, is to test the entire protection scheme as a unit, from the secondary windings of voltage and current sources to breaker tripping. For practical ongoing verification, sections of the Protection System may be tested or monitored individually. The boundaries of the verified sections must overlap to ensure that there are no gaps in the verification. See Appendix A of this Supplementary Reference for additional discussion on this topic.

All of the methodologies expressed within this report may be combined by an entity, as appropriate, to establish and operate a maintenance program. For example, a Protection System may be divided into multiple overlapping sections with a different maintenance methodology for each section:

- Time-based maintenance with appropriate maximum verification intervals for categories of equipment, as given in the Tables 1-1 through 1-5;
- Monitoring as described in Tables 1-1 through 1-5;
- A Performance-Based Maintenance program as described in Section 9 above, or Attachment A of the standard;
- Opportunistic verification using analysis of Fault records, as described in Section 11

10.1 Frequently Asked Questions:

My system has alarms that are gathered once daily through an auto-polling system; this is not really a conventional SCADA system but does it meet the Table 1 requirements for inclusion as a monitored system?

Yes, provided the auto-polling that gathers the alarms reports those alarms to a location where the action can be initiated to correct the Unresolved Maintenance Issue. This location does not have to be the location of the engineer or the technician that will eventually repair the problem, but rather a location where the action can be initiated.

11. Monitoring by Analysis of Fault Records

Many users of microprocessor relays retrieve Fault event records and oscillographic records by data communications after a Fault. They analyze the data closely if there has been an apparent Misoperation, as NERC standards require. Some advanced users have commissioned automatic Fault record processing systems that gather and archive the data. They search for evidence of component failures or setting problems hidden behind an operation whose overall outcome seems to be correct. The relay data may be augmented with independently captured Digital Fault Recorder (DFR) data retrieved for the same event.

Fault data analysis comprises a legitimate CBM program that is capable of reducing the need for a manual time-interval based check on Protection Systems whose operations are analyzed. Even electromechanical Protection Systems instrumented with DFR channels may achieve some CBM benefit. The completeness of the verification then depends on the number and variety of Faults in the vicinity of the relay that produce relay response records and the specific data captured.

A typical Fault record will verify particular parts of certain Protection Systems in the vicinity of the Fault. For a given Protection System installation, it may or may not be possible to gather within a reasonable amount of time an ensemble of internal and external Fault records that completely verify the Protection System.

For example, Fault records may verify that the particular relays that tripped are able to trip via the control circuit path that was specifically used to clear that Fault. A relay or DFR record may indicate correct operation of the protection communications channel. Furthermore, other nearby Protection Systems may verify that they restrain from tripping for a Fault just outside their respective zones of protection. The ensemble of internal Fault and nearby external Fault event data can verify major portions of the Protection System, and reset the time clock for the Table 1 testing intervals for the verified components only.

What can be shown from the records of one operation is very specific and limited. In a panel with multiple relays, only the specific relay(s) whose operation can be observed without ambiguity should be used. Be careful about using Fault response data to verify that settings or calibration are correct. Unless records have been captured for multiple Faults close to either side of a setting boundary, setting or calibration could still be incorrect.

PMU data, much like DME data, can be utilized to prove various components of the Protection System. Obviously, care must be taken to attribute proof only to the parts of a Protection System that can actually be proven using the PMU or DME data.

If Fault record data is used to show that portions or all of a Protection System have been verified to meet Table 1 requirements, the owner must retain the Fault records used, and the maintenance-related conclusions drawn from this data and used to defer Table 1 tests, for at least the retention time interval given in Section 8.2.

11.1 Frequently Asked Questions:

I use my protective relays for Fault and Disturbance recording, collecting oscillographic records and event records via communications for Fault analysis to meet NERC and DME requirements. What are the maintenance requirements for the relays?

For relays used only as Disturbance Monitoring Equipment, NERC Standard PRC-018-1 R3 & R6 states the maintenance requirements and is being addressed by a standards activity that is revising PRC-002-1 and PRC-018-1. For protective relays “that are designed to provide protection for the BES,” this standard applies, even if they also perform DME functions.

12. Importance of Relay Settings in Maintenance Programs

In manual testing programs, many utilities depend on pickup value or zone boundary tests to show that the relays have correct settings and calibration. Microprocessor relays, by contrast, provide the means for continuously monitoring measurement accuracy. Furthermore, the relay digitizes inputs from one set of signals to perform all measurement functions in a single self-monitoring microprocessor system. These relays do not require testing or calibration of each setting.

However, incorrect settings may be a bigger risk with microprocessor relays than with older relays. Some microprocessor relays have hundreds or thousands of settings, many of which are critical to Protection System performance.

Monitoring does not check measuring element settings. Analysis of Fault records may or may not reveal setting problems. To minimize risk of setting errors after commissioning, the user should enforce strict settings data base management, with reconfirmation (manual or automatic) that the installed settings are correct whenever maintenance activity might have changed them; for background and guidance, see [5] in References.

Table 1 requires that settings must be verified to be as specified. The reason for this requirement is simple: With legacy relays (non-microprocessor protective relays), it is necessary to know the value of the intended setting in order to test, adjust and calibrate the relay. Proving that the relay works per specified setting was the de facto procedure. However, with the advanced microprocessor relays, it is possible to change relay settings for the purpose of verifying specific functions and then neglect to return the settings to the specified values. While there is no specific requirement to maintain a settings management process, there remains a need to verify that the settings left in the relay are the intended, specified settings. This need may manifest itself after any of the following:

- One or more settings are changed for any reason.
- A relay fails and is repaired or replaced with another unit.
- A relay is upgraded with a new firmware version.

12.1 Frequently Asked Questions:

How do I approach testing when I have to upgrade firmware of a microprocessor relay?

The entity should ensure that the relay continues to function properly after implementation of firmware changes. Some entities may have a R&D department that might routinely run acceptance tests on devices with firmware upgrades before allowing the upgrade to be installed. Other entities may rely upon the vigorous testing of the firmware OEM. An entity has the latitude to install devices and/or programming that they believe will perform to their satisfaction. If an entity should choose to perform the maintenance activities specified in the Tables following a firmware upgrade, then they may, if they choose, reset the time clock on that set of maintenance activities so that they would not have to repeat the maintenance on its regularly scheduled cycle.

(However, for simplicity in maintenance schedules, some entities may choose to not reset this time clock; it is merely a suggested option.)

If I upgrade my old relays, then do I have to maintain my previous equipment maintenance documentation?

If an equipment item is repaired or replaced, then the entity can restart the maintenance-activity-time-interval-clock, if desired; however, the replacement of equipment does not remove any documentation requirements. The requirements in the standard are intended to ensure that an entity has a maintenance plan, and that the entity adheres to minimum activities and maximum time intervals. The documentation requirements are intended to help an entity demonstrate compliance. For example, saving the dates and records of the last two maintenance activities is intended to demonstrate compliance with the interval. Therefore, if you upgrade or replace equipment, then you still must maintain the documentation for the previous equipment, thus demonstrating compliance with the time interval requirement prior to the replacement action.

We have a number of installations where we have changed our Protection System components. Some of the changes were upgrades, but others were simply system rating changes that merely required taking relays “out-of-service”. What are our responsibilities when it comes to “out-of-service” devices?

Assuming that your system up-rates, upgrades and overall changes meet any and all other requirements and standards, then the requirements of PRC-005-4 are simple – if the Protection System component performs a Protection System function, then it must be maintained. If the component no longer performs Protection System functions, then it does not require maintenance activities under the Tables of PRC-005-4. While many entities might physically remove a component that is no longer needed, there is no requirement in PRC-005-4 to remove such component(s). Obviously, prudence would dictate that an “out-of-service” device is truly made inactive. There are no record requirements listed in PRC-005-4 for Protection System components not used.

While performing relay testing of a protective device on our Bulk Electric System, it was discovered that the protective device being tested was either broken or out of calibration. Does this satisfy the relay testing requirement, even though the protective device tested bad, and may be unable to be placed back into service?

Yes, PRC-005-4 requires entities to perform relay testing on protective devices on a given maintenance cycle interval. By performing this testing, the entity has satisfied PRC-005-4 requirement, although the protective device may be unable to be returned to service under normal calibration adjustments. R5 states:

“R5. Each Transmission Owner, Generator Owner, and Distribution Provider shall demonstrate efforts to correct any identified Unresolved Maintenance Issues.”

Also, when a failure occurs in a Protection System, power system security may be comprised, and notification of the failure must be conducted in accordance with relevant NERC standards.

If I show the protective device out of service while it is being repaired, then can I add it back as a new protective device when it returns? If not, my relay testing history would show that I was out of compliance for the last maintenance cycle.

The maintenance and testing requirements (R5) state “...shall demonstrate efforts to correct any identified Unresolved Maintenance Issues...” The type of corrective activity is not stated; however, it could include repairs or replacements.

Your documentation requirements will increase, of course, to demonstrate that your device tested bad and had corrective actions initiated. Your regional entity might ask about the status of your corrective actions.

13. Self-Monitoring Capabilities and Limitations

Microprocessor relay proponents have cited the self-monitoring capabilities of these products for nearly 20 years. Theoretically, any element that is monitored does not need a periodic manual test. A problem today is that the community of manufacturers and users has not created clear documentation of exactly what is and is not monitored. Some unmonitored but critical elements are buried in installed systems that are described as self-monitoring.

To utilize the extended time intervals allowed by monitoring, the user must document that the monitoring attributes of the device match the minimum requirements listed in the Table 1.

Until users are able to document how all parts of a system which are required for the protective functions are monitored or verified (with help from manufacturers), they must continue with the unmonitored intervals established in Tables [1](#), [3](#), [4](#) and [5 and any associated sub-tables](#) [Table 3](#).

Going forward, manufacturers and users can develop mappings of the monitoring within relays, and monitoring coverage by the relay of user circuits connected to the relay terminals.

To enable the use of the most extensive monitoring (and never again have a hands-on maintenance requirement), the manufacturers of the microprocessor-based self-monitoring components in the Protection System should publish for the user a document or map that shows:

- How all internal elements of the product are monitored for any failure that could impact Protection System performance.
- Which connected circuits are monitored by checks implemented within the product; how to connect and set the product to assure monitoring of these connected circuits; and what circuits or potential problems are not monitored.

This manufacturer's information can be used by the registered entity to document compliance of the monitoring attributes requirements by:

- Presenting or referencing the product manufacturer's documents.
- Explaining in a system design document the mapping of how every component and circuit that is critical to protection is monitored by the microprocessor product(s) or by other design features.
- Extending the monitoring to include the alarm transmission Facilities through which failures are reported within a given time frame to allocate where action can be taken to initiate resolution of the alarm attributed to an Unresolved Maintenance Issue, so that failures of monitoring or alarming systems also lead to alarms and action.
- Documenting the plans for verification of any unmonitored components according to the requirements of Tables [1](#), [3](#), [4](#) and [5 and any associated sub-tables](#) [Table 3](#).

13.1 Frequently Asked Questions:

I can't figure out how to demonstrate compliance with the requirements for the highest level of monitoring of Protection Systems. Why does this Maintenance Standard describe a maintenance program approach I cannot achieve?

Demonstrating compliance with the requirements for the highest level of monitoring any particular component of Protection Systems is likely to be very involved, and may include detailed manufacturer documentation of complete internal monitoring within a device, comprehensive design drawing reviews, and other detailed documentation. This standard does not presume to specify what documentation must be developed; only that it must be documented.

There may actually be some equipment available that is capable of meeting these highest levels of monitoring criteria, in which case it may be maintained according to the highest level of monitoring shown on the Tables. However, even if there is no equipment available today that can meet this level of monitoring, the standard establishes the necessary requirements for when such equipment becomes available.

By creating a roadmap for development, this provision makes the standard technology-neutral. The Standard Drafting Team wants to avoid the need to revise the standard in a few years to accommodate technology advances that may be coming to the industry.

14. Notification of Protection System or Automatic Reclosing Failures

When a failure occurs in a Protection System or Automatic Reclosing, power system security may be compromised, and notification of the failure must be conducted in accordance with relevant NERC standard(s). Knowledge of the failure may impact the system operator's decisions on acceptable Loading conditions.

This formal reporting of the failure and repair status to the system operator by the Protection System or Automatic Reclosing owner also encourages the system owner to execute repairs as rapidly as possible. In some cases, a microprocessor relay or carrier set can be replaced in hours; wiring termination failures may be repaired in a similar time frame. On the other hand, a component in an electromechanical or early-generation electronic relay may be difficult to find and may hold up repair for weeks. In some situations, the owner may have to resort to a temporary protection panel, or complete panel replacement.

15. Maintenance Activities

Some specific maintenance activities are a requirement to ensure reliability. An example would be that a BES entity could be prudent in its protective relay maintenance, but if its battery maintenance program is lacking, then reliability could still suffer. The NERC glossary outlines a Protection System as containing specific components. PRC-005-4 requires specific maintenance activities be accomplished within a specific time interval. As noted previously, higher technology equipment can contain integral monitoring capability that actually performs maintenance verification activities routinely and often; therefore, *manual intervention* to perform certain activities on these type components may not be needed.

15.1 Protective Relays (Table 1-1)

These relays are defined as the devices that receive the input signal from the current and voltage sensing devices and are used to isolate a Faulted Element of the BES. Devices that sense thermal, vibration, seismic, gas, or any other non-electrical inputs are excluded.

Non-microprocessor based equipment is treated differently than microprocessor-based equipment in the following ways; the relays should meet the asset owners' tolerances:

- Non-microprocessor devices must be tested with voltage and/or current applied to the device.
- Microprocessor devices may be tested through the integral testing of the device.
 - There is no specific protective relay commissioning test or relay routine test mandated.
 - There is no specific documentation mandated.

15.1.1 Frequently Asked Questions:

What calibration tolerance should be applied on electromechanical relays?

Each entity establishes their own acceptable tolerances when applying protective relaying on their system. For some Protection System components, adjustment is required to bring measurement accuracy within the parameters established by the asset owner based on the specific application of the component. A calibration failure is the result if testing finds the specified parameters to be out of tolerance.

15.2 Voltage & Current Sensing Devices (Table 1-3)

These are the current and voltage sensing devices, usually known as instrument transformers. There is presently a technology available (fiber-optic Hall-effect) that does not utilize conventional transformer technology; these devices and other technologies that produce quantities that represent the primary values of voltage and current are considered to be a type of voltage and current sensing devices included in this standard.

The intent of the maintenance activity is to verify the input to the protective relay from the device that produces the current or voltage signal sample.

There is no specific test mandated for these components. The important thing about these signals is to know that the expected output from these components actually reaches the protective relay. Therefore, the proof of the proper operation of these components also demonstrates the integrity of the wiring (or other medium used to convey the signal) from the current and voltage sensing device, all the way to the protective relay. The following observations apply:

- There is no specific ratio test, routine test or commissioning test mandated.
- There is no specific documentation mandated.
- It is required that the signal be present at the relay.
- This expectation can be arrived at from any of a number of means; including, but not limited to, the following: By calculation, by comparison to other circuits, by commissioning tests, by thorough inspection, or by any means needed to verify the circuit meets the asset owner's Protection System maintenance program.
- An example of testing might be a saturation test of a CT with the test values applied at the relay panel; this, therefore, tests the CT, as well as the wiring from the relay all the back to the CT.
- Another possible test is to measure the signal from the voltage and/or current sensing devices, during Load conditions, at the input to the relay.
- Another example of testing the various voltage and/or current sensing devices is to query the microprocessor relay for the Real-time Loading; this can then be compared to other devices to verify the quantities applied to this relay. Since the input devices have supplied the proper values to the protective relay, then the verification activity has been satisfied. Thus, event reports (and oscillographs) can be used to verify that the voltage and current sensing devices are performing satisfactorily.
- Still another method is to measure total watts and VARs around the entire bus; this should add up to zero watts and zero VARs, thus proving the voltage and/or current sensing devices system throughout the bus.
- Another method for proving the voltage and/or current-sensing devices is to complete commissioning tests on all of the transformers, cabling, fuses and wiring.
- Any other method that verifies the input to the protective relay from the device that produces the current or voltage signal sample.

15.2.1 Frequently Asked Questions:

What is meant by "... verify the current and voltage circuit inputs from the voltage and current sensing devices to the protective relays ..." Do we need to perform ratio, polarity and saturation tests every few years?

No. You must verify that the protective relay is receiving the expected values from the voltage and current-sensing devices (typically voltage and current transformers). This can be as difficult as is proposed by the question (with additional testing on the cabling and substation wiring to ensure that the values arrive at the relays); or simplicity can be achieved by other verification methods. While some examples follow, these are not intended to represent an all-inclusive list; technology advances and ingenuity should not be excluded from making comparisons and verifications:

- Compare the secondary values, at the relay, to a metering circuit, fed by different current transformers, monitoring the same line as the questioned relay circuit.
- Compare the individual phase secondary values at the relay panel (with additional testing on the panel wiring to ensure that the values arrive at those relays) with the other phases, and verify that residual currents are within expected bounds.
- Observe all three phase currents and the residual current at the relay panel with an oscilloscope, observing comparable magnitudes and proper phase relationship, with additional testing on the panel wiring to ensure that the values arrive at the relays.
- Compare the values, as determined by the questioned relay (such as, but not limited to, a query to the microprocessor relay) to another protective relay monitoring the same line, with currents supplied by different CTs.
- Compare the secondary values, at the relay with values measured by test instruments (such as, but not limited to multi-meters, voltmeter, clamp-on ammeters, etc.) and verified by calculations and known ratios to be the values expected. For example, a single PT on a 100KV bus will have a specific secondary value that, when multiplied by the PT ratio, arrives at the expected bus value of 100KV.
- Query SCADA for the power flows at the far end of the line protected by the questioned relay, compare those SCADA values to the values as determined by the questioned relay.
- Totalize the Watts and VARs on the bus and compare the totals to the values as seen by the questioned relay.

The point of the verification procedure is to ensure that all of the individual components are functioning properly; and that an ongoing proactive procedure is in place to re-check the various components of the protective relay measuring Systems.

Is wiring insulation or hi-pot testing required by this Maintenance Standard?

No, wiring insulation and equipment hi-pot testing are not specifically required by the Maintenance Standard. However, if the method of verifying CT and PT inputs to the relay involves some other method than actual observation of current and voltage transformer secondary inputs to the relay, it might be necessary to perform some sort of cable integrity test to verify that the instrument transformer secondary signals are actually making it to the relay and not being

shunted off to ground. For instance, you could use CT excitation tests and PT turns ratio tests and compare to baseline values to verify that the instrument transformer outputs are acceptable. However, to conclude that these acceptable transformer instrument output signals are actually making it to the relay inputs, it also would be necessary to verify the insulation of the wiring between the instrument transformer and the relay.

My plant generator and transformer relays are electromechanical and do not have metering functions, as do microprocessor-based relays. In order for me to compare the instrument transformer inputs to these relays to the secondary values of other metered instrument transformers monitoring the same primary voltage and current signals, it would be necessary to temporarily connect test equipment, like voltmeters and clamp on ammeters, to measure the input signals to the relays. This practice seems very risky, and a plant trip could result if the technician were to make an error while measuring these current and voltage signals. How can I avoid this risk? Also, what if no other instrument transformers are available which monitor the same primary voltage or current signal?

Comparing the input signals to the relays to the outputs of other independent instrument transformers monitoring the same primary current or voltage is just one method of verifying the instrument transformer inputs to the relays, but is not required by the standard. Plants can choose how to best manage their risk. If online testing is deemed too risky, offline tests, such as, but not limited to, CT excitation test and PT turns ratio tests can be compared to baseline data and be used in conjunction with CT and PT secondary wiring insulation verification tests to adequately “verify the current and voltage circuit inputs from the voltage and current sensing devices to the protective relays ...” while eliminating the risk of tripping an in service generator or transformer. Similarly, this same offline test methodology can be used to verify the relay input voltage and current signals to relays when there are no other instrument transformers monitoring available for purposes of signal comparison.

15.3 Control circuitry associated with protective functions (Table 1-5)

This component of Protection Systems includes the trip coil(s) of the circuit breaker, circuit switcher or any other interrupting device. It includes the wiring from the batteries to the relays. It includes the wiring (or other signal conveyance) from every trip output to every trip coil. It includes any device needed for the correct processing of the needed trip signal to the trip coil of the interrupting device; this requirement is meant to capture inputs and outputs to and from a protective relay that are necessary for the correct operation of the protective functions. In short, every trip path must be verified; the method of verification is optional to the asset owner. An example of testing methods to accomplish this might be to verify, with a volt-meter, the existence of the proper voltage at the open contacts, the open circuited input circuit and at the trip coil(s). As every parallel trip path has similar failure modes, each trip path from relay to trip coil must be verified. Each trip coil must be tested to trip the circuit breaker (or other interrupting device) at least once. There is a requirement to operate the circuit breaker (or other interrupting device) at least once every six years as part of the complete functional test. If a suitable monitoring system is installed that verifies every parallel trip path, then the manual-intervention testing of those parallel trip paths can be eliminated; however, the actual operation of the circuit breaker must still occur at least once every six years. This six-year tripping requirement can be completed as easily as tracking the Real-time Fault-clearing operations on the circuit breaker, or tracking the trip coil(s) operation(s) during circuit breaker routine maintenance actions.

The circuit-interrupting device should not be confused with a motor-operated disconnect. The intent of this standard is to require maintenance intervals and activities on Protection Systems equipment, and not just all system isolating equipment.

It is necessary, however, to classify a device that actuates a high-speed auto-closing ground switch as an interrupting device, if this ground switch is utilized in a Protection System and forces a ground Fault to occur that then results in an expected Protection System operation to clear the forced ground Fault. The SDT believes that this is essentially a transferred-tripping device without the use of communications equipment. If this high-speed ground switch is “...designed to provide protection for the BES...” then this device needs to be treated as any other Protection System component. The control circuitry would have to be tested within 12 years, and any electromechanically operated device will have to be tested every six years. If the spring-operated ground switch can be disconnected from the solenoid triggering unit, then the solenoid triggering unit can easily be tested without the actual closing of the ground blade.

The dc control circuitry also includes each auxiliary tripping relay (94) and each lock-out relay (86) that may exist in any particular trip scheme. If the lock-out relays (86) are electromechanical type components, then they must be trip tested. The PSMT SDT considers these components to share some similarities in failure modes as electromechanical protective relays; as such, there is a six-year maximum interval between mandated maintenance tasks unless PBM is applied.

Contacts of the 86 and/or 94 that pass the trip current on to the circuit interrupting device trip coils will have to be checked as part of the 12 year requirement. Contacts of the 86 and/or 94 lock relay that operate non-BES interrupting devices are not required. Normally-open contacts that are not used to pass a trip signal and normally-closed contacts do not have to be verified. Verification of the tripping paths is the requirement.

New technology is also accommodated here; there are some tripping systems that have replaced the traditional hard-wired trip circuitry with other methods of trip-signal conveyance such as fiber-optics. It is the intent of the PSMT SDT to include this, and any other, technology that is used to convey a trip signal from a protective relay to a circuit breaker (or other interrupting device) within this category of equipment. The requirement for these systems is verification of the tripping path.

Monitoring of the control circuit integrity allows for no maintenance activity on the control circuit (excluding the requirement to operate trip coils and electromechanical lockout and/or tripping auxiliary relays). Monitoring of integrity means to monitor for continuity and/or presence of voltage on each trip path. For Ethernet or fiber-optic control systems, monitoring of integrity means to monitor communication ability between the relay and the circuit breaker.

15.3.1 Frequently Asked Questions:

Is it permissible to verify circuit breaker tripping at a different time (and interval) than when we verify the protective relays and the instrument transformers?

Yes, provided the entire Protective System is tested within the individual component’s maximum allowable testing intervals.

The Protection System Maintenance Standard describes requirements for verifying the tripping of circuit breakers. What is this telling me about maintenance of circuit breakers?

Requirements in PRC-005-4 are intended to verify the integrity of tripping circuits, including the breaker trip coil, as well as the presence of auxiliary supply (usually a battery) for energizing the trip coil if a protection function operates. Beyond this, PRC-005-4 sets no requirements for verifying circuit breaker performance, or for maintenance of the circuit breaker.

How do I test each dc Control Circuit trip path, as established in Table 1-5 "Protection System Control Circuitry (Trip coils and auxiliary relays)"?

Table 1-5 specifies that each breaker trip coil and lockout relays that carry trip current to a trip coil must be operated within the specified time period. The required operations may be via targeted maintenance activities, or by documented operation of these devices for other purposes such as Fault clearing.

Are high-speed ground switch trip coils included in the dc control circuitry?

Yes. PRC-005-4 includes high-speed grounding switch trip coils within the dc control circuitry to the degree that the initiating Protection Systems are characterized as "transmission Protection Systems."

Does the control circuitry and trip coil of a non-BES breaker, tripped via a BES protection component, have to be tested per Table 1.5? (Refer to Table 3 for examples 1 and 2)

Example 1: A non-BES circuit breaker that is tripped via a Protection System to which PRC-005-4 applies might be (but is not limited to) a 12.5KV circuit breaker feeding (non-black-start) radial Loads but has a trip that originates from an under-frequency (81) relay.

- The relay must be verified.
- The voltage signal to the relay must be verified.
- All of the relevant dc supply tests still apply.
- The unmonitored trip circuit between the relay and any lock-out or auxiliary relay must be verified every 12 years.
- The unmonitored trip circuit between the lock-out (or auxiliary relay) and the non-BES breaker does not have to be proven with an electrical trip.
- In the case where there is no lock-out or auxiliary tripping relay used, the trip circuit to the non-BES breaker does not have to be proven with an electrical trip.
- The trip coil of the non-BES circuit breaker does not have to be individually proven with an electrical trip.

Example 2: A Transmission Owner may have a non-BES breaker that is tripped via a Protection System to which PRC-005-4 applies, which may be (but is not limited to) a 13.8 KV circuit breaker feeding (non-black-start) radial Loads but has a trip that originates from a BES 115KV line relay.

- The relay must be verified
- The voltage signal to the relay must be verified
- All of the relevant dc supply tests still apply

-
- The unmonitored trip circuit between the relay and any lock-out (86) or auxiliary (94) relay must be verified every 12 years
 - The unmonitored trip circuit between the lock-out (86) (or auxiliary (94)) relay and the non-BES breaker does not have to be proven with an electrical trip
 - In the case where there is no lockout (86) or auxiliary (94) tripping relay used, the trip circuit to the non-BES breaker does not have to be proven with an electrical trip.
 - The trip coil of the non-BES circuit breaker does not have to be individually proven with an electrical trip

Example 3: A Generator Owner may have a non-BES circuit breaker that is tripped via a Protection System to which PRC-005-4 applies, such as the generator field breaker and low-side breakers on station service/excitation transformers connected to the generator bus.

Trip testing of the generator field breaker and low side station service/excitation transformer breaker(s) via lockout or auxiliary tripping relays are not required since these breakers may be associated with radially fed loads and are not considered to be BES breakers. An example of an otherwise non-BES circuit breaker that is tripped via a BES protection component might be (but is not limited to) a 6.9kV station service transformer source circuit breaker but has a trip that originates from a generator differential (87) relay.

- The differential relay must be verified.
- The current signals to the relay must be verified.
- All of the relevant dc supply tests still apply.
- The unmonitored trip circuit between the relay and any lock-out or auxiliary relay must be verified every 12 years.
- The unmonitored trip circuit between the lock-out (or auxiliary relay) and the non-BES breaker does not have to be proven with an electrical trip.
- In the case where there is no lock-out or auxiliary tripping relay used, the trip circuit to the non-BES breaker does not have to be proven with an electrical trip.
- The trip coil of the non-BES circuit breaker does not have to be individually proven with an electrical trip.

However, it is very prudent to verify the tripping of such breakers for the integrity of the overall generation plant.

Do I have to verify operation of breaker "a" contacts or any other normally closed auxiliary contacts in the trip path of each breaker as part of my control circuit test?

Operation of normally-closed contacts does not have to be verified. Verification of the tripping paths is the requirement. The continuity of the normally closed contacts will be verified when the tripping path is verified.

15.4 Batteries and DC Supplies (Table 1-4)

The NERC definition of a Protection System is:

- Protective relays which respond to electrical quantities,

-
- Communications Systems necessary for correct operation of protective functions,
 - Voltage and current sensing devices providing inputs to protective relays,
 - Station dc supply associated with protective functions (including station batteries, battery chargers, and non-battery-based dc supply), and
 - Control circuitry associated with protective functions through the trip coil(s) of the circuit breakers or other interrupting devices.

The station battery is not the only component that provides dc power to a Protection System. In the new definition for Protection System, “station batteries” are replaced with “station dc supply” to make the battery charger and dc producing stored energy devices (that are not a battery) part of the Protection System that must be maintained.

The PSMT SDT recognizes that there are several technological advances in equipment and testing procedures that allow the owner to choose how to verify that a battery string is free of open circuits. The term “continuity” was introduced into the standard to allow the owner to choose how to verify continuity of a battery set by various methods, and not to limit the owner to other conventional methods of showing continuity. Continuity, as used in Table 1-4 of the standard, refers to verifying that there is a continuous current path from the positive terminal of the station battery set to the negative terminal. Without verifying continuity of a station battery, there is no way to determine that the station battery is available to supply dc power to the station. An open battery string will be an unavailable power source in the event of loss of the battery charger.

Batteries cannot be a unique population segment of a Performance-Based Maintenance Program (PBM) because there are too many variables in the electrochemical process to completely isolate all of the performance-changing criteria necessary for using PBM on battery Systems. However, nothing precludes the use of a PBM process for any other part of a dc supply besides the batteries themselves.

15.4.1 Frequently Asked Questions:

What constitutes the station dc supply, as mentioned in the definition of Protective System?

The previous definition of Protection System includes batteries, but leaves out chargers. The latest definition includes chargers, as well as dc systems that do not utilize batteries. This revision of PRC-005-4 is intended to capture these devices that were not included under the previous definition. The station direct current (dc) supply normally consists of two components: the battery charger and the station battery itself. There are also emerging technologies that provide a source of dc supply that does not include either a battery or charger.

Battery Charger - The battery charger is supplied by an available ac source. At a minimum, the battery charger must be sized to charge the battery (after discharge) and supply the constant dc load. In many cases, it may be sized also to provide sufficient dc current to handle the higher energy requirements of tripping breakers and switches when actuated by the protective relays in the Protection System.

Station Battery - Station batteries provide the dc power required for tripping and for supplying normal dc power to the station in the event of loss of the battery charger. There are several technologies of battery that require unique forms of maintenance as established in Table 1-4.

Emerging Technologies - Station dc supplies are currently being developed that use other energy storage technologies besides the station battery to prevent loss of the station dc supply when ac power is lost. Maintenance of these station dc supplies will require different kinds of tests and inspections. Table 1-4 presents maintenance activities and maximum allowable testing intervals for these new station dc supply technologies. However, because these technologies are relatively new, the maintenance activities for these station dc supplies may change over time.

What did the PSMT SDT mean by “continuity” of the dc supply?

The PSMT SDT recognizes that there are several technological advances in equipment and testing procedures that allow the owner to choose how to verify that a battery string is free of open circuits. The term “continuity” was introduced into the standard to allow the owner to choose how to verify continuity (no open circuits) of a battery set by various methods, and not to limit the owner to other conventional methods of showing continuity – lack of an open circuit. Continuity, as used in Table 1-4 of the standard, refers to verifying that there is a continuous current path from the positive terminal of the station battery set to the negative terminal (no open circuit). Without verifying continuity of a station battery, there is no way to determine that the station battery is available to supply dc power to the station. Whether it is caused from an open cell or a bad external connection, an open battery string will be an unavailable power source in the event of loss of the battery charger.

The current path through a station battery from its positive to its negative connection to the dc control circuits is composed of two types of elements. These path elements are the electrochemical path through each of its cells and all of the internal and external metallic connections and terminations of the batteries in the battery set. If there is loss of continuity (an open circuit) in any part of the electrochemical or metallic path, the battery set will not be available for service. In the event of the loss of the ac source or battery charger, the battery must be capable of supplying dc current, both for continuous dc loads and for tripping breakers and switches. Without continuity, the battery cannot perform this function.

At generating stations and large transmission stations where battery chargers are capable of handling the maximum current required by the Protection System, there are still problems that could potentially occur when the continuity through the connected battery is interrupted.

- Many battery chargers produce harmonics which can cause failure of dc power supplies in microprocessor-based protective relays and other electronic devices connected to station dc supply. In these cases, the substation battery serves as a filter for these harmonics. With the loss of continuity in the battery, the filter provided by the battery is no longer present.
- Loss of electrical continuity of the station battery will cause, in most battery chargers, regardless of the battery charger’s output current capability, a delayed response in full output current from the charger. Almost all chargers have an intentional one- to two-second delay to switch from a low substation dc load current to the maximum output of the charger. This delay would cause the opening of circuit breakers to be delayed, which could violate system performance standards.

Monitoring of the station dc supply voltage will not indicate that there is a problem with the dc current path through the battery, unless the battery charger is taken out of service. At that time,

a break in the continuity of the station battery current path will be revealed because there will be no voltage on the station dc circuitry. This particular test method, while proving battery continuity, may not be acceptable to all installations.

Although the standard prescribes what must be accomplished during the maintenance activity, it does not prescribe how the maintenance activity should be accomplished. There are several methods that can be used to verify the electrical continuity of the battery. These are not the only possible methods, simply a sampling of some methods:

- One method is to measure that there is current flowing through the battery itself by a simple clamp on milliamp-range ammeter. A battery is always either charging or discharging. Even when a battery is charged, there is still a measurable float charge current that can be detected to verify that there is continuity in the electrical path through the battery.
- A simple test for continuity is to remove the battery charger from service and verify that the battery provides voltage and current to the dc system. However, the behavior of the various dc-supplied equipment in the station should be considered before using this approach.
- Manufacturers of microprocessor-controlled battery chargers have developed methods for their equipment to periodically (or continuously) test for battery continuity. For example, one manufacturer periodically reduces the float voltage on the battery until current from the battery to the dc load can be measured to confirm continuity.
- Applying test current (as in some ohmic testing devices, or devices for locating dc grounds) will provide a current that when measured elsewhere in the string, will prove that the circuit is continuous.
- Internal ohmic measurements of the cells and units of lead-acid batteries (VRLA & VLA) can detect lack of continuity within the cells of a battery string; and when used in conjunction with resistance measurements of the battery's external connections, can prove continuity. Also some methods of taking internal ohmic measurements, by their very nature, can prove the continuity of a battery string without having to use the results of resistance measurements of the external connections.
- Specific gravity tests could infer continuity because without continuity there could be no charging occurring; and if there is no charging, then specific gravity will go down below acceptable levels over time.

No matter how the electrical continuity of a battery set is verified, it is a necessary maintenance activity that must be performed at the intervals prescribed by Table 1-4 to insure that the station dc supply has a path that can provide the required current to the Protection System at all times.

When should I check the station batteries to see if they have sufficient energy to perform as manufactured?

The answer to this question depends on the type of battery (valve-regulated lead-acid, vented lead-acid, or nickel-cadmium) and the maintenance activity chosen.

For example, if you have a valve-regulated lead-acid (VRLA) station battery, and you have chosen to evaluate the measured cell/unit internal ohmic values to the battery cell's baseline, you will have to perform verification at a maximum maintenance interval of no greater than

every six months. While this interval might seem to be quite short, keep in mind that the six-month interval is important for VRLA batteries; this interval provides an accumulation of data that better shows when a VRLA battery is incapable of performing as manufactured.

If, for a VRLA station battery, you choose to conduct a performance capacity test on the entire station battery as the maintenance activity, then you will have to perform verification at a maximum maintenance interval of no greater than every three calendar years.

How is a baseline established for cell/unit internal ohmic measurements?

Establishment of cell/unit internal ohmic baseline measurements should be completed when lead-acid batteries are newly installed. To ensure that the baseline ohmic cell/unit values are most indicative of the station battery's ability to perform as manufactured, they should be made at some point in time after the installation to allow the cell chemistry to stabilize after the initial freshening charge. An accepted industry practice for establishing baseline values is after six-months of installation, with the battery fully charged and in service. However, it is recommended that each owner, when establishing a baseline, should consult the battery manufacturer for specific instructions on establishing an ohmic baseline for their product, if available.

When internal ohmic measurements are taken, the same make/model test equipment should be used to establish the baseline and used for the future trending of the cells internal ohmic measurements because of variances in test equipment and the type of ohmic measurement used by different manufacturer's equipment. Keep in mind that one manufacturer's "Conductance" test equipment does not produce similar results as another manufacturer's "Conductance" test equipment, even though both manufacturers have produced "Ohmic" test equipment. Therefore, for meaningful results to an established baseline, the same make/model of instrument should be used.

For all new installations of valve-regulated lead-acid (VRLA) batteries and vented lead-acid (VLA) batteries, where trending of the cells internal ohmic measurements to a baseline are to be used to determine the ability of the station battery to perform as manufactured, the establishment of the baseline, as described above, should be followed at the time of installation to insure the most accurate trending of the cell/unit. However, often for older VRLA batteries, the owners of the station batteries have not established a baseline at installation. Also for owners of VLA batteries who want to establish a maintenance activity which requires trending of measured ohmic values to a baseline, there was typically no baseline established at installation of the station battery to trend to.

To resolve the problem of the unavailability of baseline internal ohmic measurements for the individual cell/unit of a station battery, many manufacturers of internal ohmic measurement devices have established libraries of baseline values for VRLA and VLA batteries using their testing device. Also, several of the battery manufacturers have libraries of baselines for their products that can be used to trend to. However, it is important that when using battery manufacturer-supplied data that it is verified that the baseline readings to be used were taken with the same ohmic testing device that will be used for future measurements (for example "Conductance Readings" from one manufacturer's test equipment do not correlate to "Impedance Readings" from a different manufacturer's test equipment). Although many manufacturers may have provided baseline values, which will allow trending of the internal ohmic measurements over the remaining life of a station battery, these baselines are not the actual cell/unit measurements for

the battery being trended. It is important to have a baseline tailored to the station battery to more accurately use the tool of ohmic measurement trending. That more customized baseline can only be created by following the establishment of a baseline for each cell/unit at the time of installation of the station battery.

Why determine the State of Charge?

Even though there is no present requirement to check the state of charge of a battery, it can be a very useful tool in determining the overall condition of a battery system. The following discussions are offered as a general reference.

When a battery is fully charged, the battery is available to deliver its existing capacity. As a battery is discharged, its ability to deliver its maximum available capacity is diminished. It is necessary to determine if the state of charge has dropped to an unacceptable level.

What is State of Charge and how can it be determined in a station battery?

The state of charge of a battery refers to the ratio of residual capacity at a given instant to the maximum capacity available from the battery. When a battery is fully charged, the battery is available to deliver its existing capacity. As a battery is discharged, its ability to deliver its maximum available capacity is diminished. Knowing the amount of energy left in a battery compared with the energy it had when it was fully charged gives the user an indication of how much longer a battery will continue to perform before it needs recharging.

For vented lead-acid (VLA) batteries which use accessible liquid electrolyte, a hydrometer can be used to test the specific gravity of each cell as a measure of its state of charge. The hydrometer depends on measuring changes in the weight of the active chemicals. As the battery discharges, the active electrolyte, sulfuric acid, is consumed and the concentration of the sulfuric acid in water is reduced. This, in turn, reduces the specific gravity of the solution in direct proportion to the state of charge. The actual specific gravity of the electrolyte can, therefore, be used as an indication of the state of charge of the battery. Hydrometer readings may not tell the whole story, as it takes a while for the acid to get mixed up in the cells of a VLA battery. If measured right after charging, you might see high specific gravity readings at the top of the cell, even though it is much less at the bottom. Conversely, if taken shortly after adding water to the cell, the specific gravity readings near the top of the cell will be lower than those at the bottom.

Nickel-cadmium batteries, where the specific gravity of the electrolyte does not change during battery charge and discharge, and valve-regulated lead-acid (VRLA) batteries, where the electrolyte is not accessible, cannot have their state of charge determined by specific gravity readings. For these two types of batteries, and for VLA batteries also, where another method besides taking hydrometer readings is desired, the state of charge may be determined by taking voltage and current readings at the battery terminals. The methods employed to obtain accurate readings vary for the different battery types. Manufacturers' information and IEEE guidelines can be consulted for specifics; (see IEEE 1106 Annex B for Nickel Cadmium batteries, IEEE 1188 Annex A for VRLA batteries and IEEE 450 for VLA batteries).

Why determine the Connection Resistance?

High connection resistance can cause abnormal voltage drop or excessive heating during discharge of a station battery. During periods of a high rate of discharge of the station battery, a very high resistance can cause severe damage. The maintenance requirement to verify battery terminal connection resistance in Table 1-4 is established to verify that the integrity of all battery electrical connections is acceptable. This verification includes cell-to-cell (intercell) and external

circuit terminations. Your method of checking for acceptable values of intercell and terminal connection resistance could be by individual readings, or a combination of the two. There are test methods presently that can read post termination resistances and resistance values between external posts. There are also test methods presently available that take a combination reading of the post termination connection resistance plus the intercell resistance value plus the post termination connection resistance value. Either of the two methods, or any other method, that can show if the adequacy of connections at the battery posts is acceptable.

Adequacy of the electrical terminations can be determined by comparing resistance measurements for all connections taken at the time of station battery's installation to the same resistance measurements taken at the maintenance interval chosen, not to exceed the maximum maintenance interval of Table 1-4. Trending of the interval measurements to the baseline measurements will identify any degradation in the battery connections. When the connection resistance values exceed the acceptance criteria for the connection, the connection is typically disassembled, cleaned, reassembled and measurements taken to verify that the measurements are adequate when compared to the baseline readings.

What conditions should be inspected for visible battery cells?

The maintenance requirement to inspect the cell condition of all station battery cells where the cells are visible is a maintenance requirement of Table 1-4. Station batteries are different from any other component in the Protection Station because they are a perishable product due to the electrochemical process which is used to produce dc electrical current and voltage. This inspection is a detailed visual inspection of the cells for abnormalities that occur in the aging process of the cell. In VLA battery visual inspections, some of the things that the inspector is typically looking for on the plates are signs of sulfation of the plates, abnormal colors (which are an indicator of sulfation or possible copper contamination) and abnormal conditions such as cracked grids. The visual inspection could look for symptoms of hydration that would indicate that the battery has been left in a completely discharged state for a prolonged period. Besides looking at the plates for signs of aging, all internal connections, such as the bus bar connection to each plate, and the connections to all posts of the battery need to be visually inspected for abnormalities. In a complete visual inspection for the condition of the cell the cell plates, separators and sediment space of each cell must be looked at for signs of deterioration. An inspection of the station battery's cell condition also includes looking at all terminal posts and cell-to-cell electric connections to ensure they are corrosion free. The case of the battery containing the cell, or cells, must be inspected for cracks and electrolyte leaks through cracks and the post seals.

This maintenance activity cannot be extended beyond the maximum maintenance interval of Table 1-4 by a Performance-Based Maintenance Program (PBM) because of the electrochemical aging process of the station battery, nor can there be any monitoring associated with it because there must be a visual inspection involved in the activity. A remote visual inspection could possibly be done, but its interval must be no greater than the maximum maintenance interval of Table 1-4.

Why is it necessary to verify the battery string can perform as manufactured? I only care that the battery can trip the breaker, which means that the battery can perform as designed. I oversize my batteries so that even if the battery cannot perform as manufactured, it can still trip my breakers.

The fundamental answer to this question revolves around the concept of battery performance “as designed” vs. battery performance “as manufactured.” The purpose of the various sections of Table 1-4 of this standard is to establish requirements for the Protection System owner to maintain the batteries, to ensure they will operate the equipment when there is an incident that requires dc power, and ensure the batteries will continue to provide adequate service until at least the next maintenance interval. To meet these goals, the correct battery has to be properly selected to meet the design parameters, and the battery has to deliver the power it was manufactured to provide.

When testing batteries, it may be difficult to determine the original design (i.e., load profile) of the dc system. This standard is not intended as a design document, and requirements relating to design are, therefore, not included.

Where the dc load profile is known, the best way to determine if the system will operate as designed is to conduct a service test on the battery. However, a service test alone might not fully determine if the battery is healthy. A battery with 50% capacity may be able to pass a service test, but the battery would be in a serious state of deterioration and could fail at some point in the near future.

To ensure that the battery will meet the required load profile and continue to meet the load profile until the next maintenance interval, the installed battery must be sized correctly (i.e., a correct design), and it must be in a good state of health. Since the design of the dc system is not within the scope of the standard, the only consistent and reliable method to ensure that the battery is in a good state of health is to confirm that it can perform as manufactured. If the battery can perform as manufactured and it has been designed properly, the system should operate properly until the next maintenance interval.

How do I verify the battery string can perform as manufactured?

Optimally, actual battery performance should be verified against the manufacturer’s rating curves. The best practice for evaluating battery performance is via a performance test. However, due to both logistical and system reliability concerns, some Protection System owners prefer other methods to determine if a battery can perform as manufactured. There are several battery parameters that can be evaluated to determine if a battery can perform as manufactured. Ohmic measurements and float current are two examples of parameters that have been reported to assist in determining if a battery string can perform as manufactured.

The evaluation of battery parameters in determining battery health is a complex issue, and is not an exact science. This standard gives the user an opportunity to utilize other measured parameters to determine if the battery can perform as manufactured. It is the responsibility of the Protection System owner, however, to maintain a documented process that demonstrates the chosen parameter(s) and associated methodology used to determine if the battery string can perform as manufactured.

Whatever parameters are used to evaluate the battery (ohmic measurements, float current, float voltages, temperature, specific gravity, performance test, or combination thereof), the goal is to determine the value of the measurement (or the percentage change) at which the battery fails to perform as manufactured, or the point where the battery is deteriorating so rapidly that it will not perform as manufactured before the next maintenance interval.

This necessitates the need for establishing and documenting a baseline. A baseline may be required of every individual cell, a particular battery installation, or a specific make, model, or size of a cell. Given a consistent cell manufacturing process, it may be possible to establish a baseline number for the cell (make/model/type) and, therefore, a subsequent baseline for every installation would not be necessary. However, future installations of the same battery types should be spot-checked to ensure that your baseline remains applicable.

Consistent testing methods by trained personnel are essential. Moreover, it is essential that these technicians utilize the same make/model of ohmic test equipment each time readings are taken in order to establish a meaningful and accurate trend line against the established baseline. The type of probe and its location (post, connector, etc.) for the reading need to be the same for each subsequent test. The room temperature should be recorded with the readings for each test as well. Care should be taken to consider any factors that might lead a trending program to become invalid.

Float current along with other measurable parameters can be used in lieu of or in concert with ohmic measurement testing to measure the ability of a battery to perform as manufactured. The key to using any of these measurement parameters is to establish a baseline and the point where the reading indicates that the battery will not perform as manufactured.

The establishment of a baseline may be different for various types of cells and for different types of installations. In some cases, it may be possible to obtain a baseline number from the battery manufacturer, although it is much more likely that the baseline will have to be established after the installation is complete. To some degree, the battery may still be “forming” after installation; consequently, determining a stable baseline may not be possible until several months after the battery has been in service.

The most important part of this process is to determine the point where the ohmic reading (or other measured parameter(s)) indicates that the battery cannot perform as manufactured. That point could be an absolute number, an absolute change, or a percentage change of an established baseline.

Since there are no universally-accepted repositories of this information, the Protection System owner will have to determine the value/percentage where the battery cannot perform as manufactured (heretofore referred to as a failed cell). This is the most difficult and important part of the entire process.

To determine the point where the battery fails to perform as manufactured, it is helpful to have a history of a battery type, if the data includes the parameter(s) used to evaluate the battery's ability to perform as manufactured against the actual demonstrated performance/capacity of a battery/cell.

For example, when an ohmic reading has been recorded that the user suspects is indicating a failed cell, a performance test of that cell (or string) should be conducted in order to prove/quantify that the cell has failed. Through this process, the user needs to determine the ohmic value at which the performance of the cell has dropped below 80% of the manufactured, rated performance. It is likely that there may be a variation in ohmic readings that indicates a failed cell (possibly significant). It is prudent to use the most conservative values to determine the point at which the cell should be marked for replacement. Periodically, the user should

demonstrate that an “adequate” ohmic reading equates to an adequate battery performance (>80% of capacity).

Similarly, acceptance criteria for "good" and "failed" cells should be established for other parameters such as float current, specific gravity, etc., if used to determine the ability of a battery to function as designed.

What happens if I change the make/model of ohmic test equipment after the battery has been installed for a period of time?

If a user decides to switch testers, either voluntarily or because the equipment is not supported/sold any longer, the user may have to establish a new base line and new parameters that indicate when the battery no longer performs as manufactured. The user always has a choice to perform a capacity test in lieu of establishing new parameters.

What are some of the differences between lead-acid and nickel-cadmium batteries?

There is a marked difference in the aging process of lead acid and nickel-cadmium station batteries. The difference in the aging process of these two types of batteries is chiefly due to the electrochemical process of the battery type. Aging and eventual failure of lead acid batteries is due to expansion and corrosion of the positive grid structure, loss of positive plate active material, and loss of capacity caused by physical changes in the active material of the positive plates. In contrast, the primary failure of nickel-cadmium batteries is due to the gradual linear aging of the active materials in the plates. The electrolyte of a nickel-cadmium battery only facilitates the chemical reaction (it functions only to transfer ions between the positive and negative plates), but is not chemically altered during the process like the electrolyte of a lead acid battery. A lead acid battery experiences continued corrosion of the positive plate and grid structure throughout its operational life while a nickel-cadmium battery does not.

Changes to the properties of a lead acid battery when periodically measured and trended to a baseline, can indicate aging of the grid structure, positive plate deterioration, or changes in the active materials in the plate.

Because of the clear differences in the aging process of lead acid and nickel-cadmium batteries, there are no significantly measurable properties of the nickel-cadmium battery that can be measured at a periodic interval and trended to determine aging. For this reason, Table 1-4(c) (Protection System Station dc supply Using nickel-cadmium [NiCad] Batteries) only specifies one minimum maintenance activity and associated maximum maintenance interval necessary to verify that the station battery can perform as manufactured by evaluating cell/unit measurements indicative of battery performance against the station battery baseline. This maintenance activity is to conduct a performance or modified performance capacity test of the entire battery bank.

Why in Table 1-4 of PRC-005-4 is there a maintenance activity to inspect the structural integrity of the battery rack?

The purpose of this inspection is to verify that the battery rack is correctly installed and has no deterioration that could weaken its structural integrity.

Because the battery rack is specifically manufactured for the battery that is mounted on it, weakening of its structural members by rust or corrosion can physically jeopardize the battery.

What is required to comply with the “Unintentional dc Grounds” requirement?

In most cases, the first ground that appears on a battery is not a problem. It is the unintentional ground that appears on the opposite pole that becomes problematic. Even then many systems are designed to operate favorably under some unintentional ~~DC~~ dc ground situations. It is up to the owner of the Protection System to determine if corrective actions are needed on detected unintentional ~~DC~~ dc grounds. The standard merely requires that a check be made for the existence of u ~~DC~~ dc grounds. Obviously, a “check-off” of some sort will have to be devised by the inspecting entity to document that a check is routinely done for u ~~DC~~ dc grounds because of the possible consequences to the Protection System.

Where the standard refers to “all cells,” is it sufficient to have a documentation method that refers to “all cells,” or do we need to have separate documentation for every cell? For example, do I need 60 individual documented check-offs for good electrolyte level, or would a single check-off per bank be sufficient?

A single check-off per battery bank is sufficient for documentation, as long as the single check-off attests to checking all cells/units.

Does this standard refer to Station batteries or all batteries; for example, Communications Site Batteries?

This standard refers to Station Batteries. The drafting team does not believe that the scope of this standard refers to communications sites. The batteries covered under PRC-005-4 are the batteries that supply the trip current to the trip coils of the interrupting devices that are a part of the Protection System. The SDT believes that a loss of power to the communications systems at a remote site would cause the communications systems associated with protective relays to alarm at the substation. At this point, the corrective actions can be initiated.

What are cell/unit internal ohmic measurements?

With the introduction of Valve-Regulated Lead-Acid (VRLA) batteries to station dc supplies in the 1980’s several of the standard maintenance tools that are used on Vented Lead-Acid (VLA) batteries were unable to be used on this new type of lead-acid battery to determine its state of health. The only tools that were available to give indication of the health of these new VRLA batteries were voltage readings of the total battery voltage, the voltage of the individual cells and periodic discharge tests.

In the search for a tool for determining the health of a VRLA battery several manufacturers studied the electrical model of a lead acid battery’s current path through its cell. The overall battery current path consists of resistance and inductive and capacitive reactance. The inductive reactance in the current path through the battery is so minuscule when compared to the huge capacitive reactance of the cells that it is often ignored in most circuit models of the battery cell. Taking the basic model of a battery cell manufacturers of battery test equipment have developed and marketed testing devices to take measurements of the current path to detect degradation in the internal path through the cell.

In the battery industry, these various types of measurements are referred to as ohmic measurements. Terms used by the industry to describe ohmic measurements are ac conductance, ac impedance, and dc resistance. They are defined by the test equipment providers and IEEE and refer to the method of taking ohmic measurements of a lead acid battery. For example, in one manufacturer’s ac conductance equipment measurements are taken by applying a voltage of a known frequency and amplitude across a cell or battery unit and observing the ac

current flow it produces in response to the voltage. A manufacturer of an ac impedance meter measures ac current of a known frequency and amplitude that is passed through the whole battery string and determines the impedances of each cell or unit by measuring the resultant ac voltage drop across them. On the other hand, dc resistance of a cell is measured by a third manufacturer's equipment by applying a dc load across the cell or unit and measuring the step change in both the voltage and current to calculate the internal dc resistance of the cell or unit.

It is important to note that because of the rapid development of the market for ohmic measurement devices, there were no standards developed or used to mandate the test signals used in making ohmic measurements. Manufacturers using proprietary methods and applying different frequencies and magnitudes for their signals have developed a diversity of measurement devices. This diversity in test signals coupled with the three different types of ohmic measurements techniques (impedance conductance and resistance) make it impossible to always get the same ohmic measurement for a cell with different ohmic measurement devices. However, IEEE has recognized the great value for choosing one device for ohmic measurement, no matter who makes it or the method to calculate the ohmic measurement. The only caution given by IEEE and the battery manufacturers is that when trending the cells of a lead acid station battery consistent ohmic measurement devices should be used to establish the baseline measurement and to trend the battery set for its entire life.

For VRLA batteries both IEEE Standard 1188 (Maintenance, Testing and Replacement of VRLA Batteries) and IEEE Standard 1187 (Installation Design and Installation of VRLA Batteries) recognize the importance of the maintenance activity of establishing a baseline for "cell/unit internal ohmic measurements (impedance, conductance and resistance)" and trending them at frequent intervals over the life of the battery. There are extensive discussions about the need for taking these measurements in these standards. IEEE Standard 1188 requires taking internal ohmic values as described in Annex C4 during regular inspections of the station battery. For VRLA batteries IEEE Standard 1188 in talking about the necessity of establishing a baseline and trending it over time says, "...depending on the degree of change a performance test, cell replacement or other corrective action may be necessary..." (IEEE std 1188-2005, C.4 page 18).

For VLA batteries IEEE Standard 484 (Installation of VLA batteries) gives several guidelines about establishing baseline measurements on newly installed lead acid stationary batteries. The standard also discusses the need to look for significant changes in the ohmic measurements, the caution that measurement data will differ with each type of model of instrument used, and lists a number of factors that affect ohmic measurements.

At the beginning of the 21st century, EPRI conducted a series of extensive studies to determine the relationship of internal ohmic measurements to the capacity of a lead acid battery cell. The studies indicated that internal ohmic measurements were in fact a good indicator of a lead acid battery cell's capacity, but because users often were only interested in the total station battery capacity and the technology does not precisely predict overall battery capacity, if a user only needs "an accurate measure of the overall battery capacity," they should "perform a battery capacity test."

Prior to the EPRI studies some large and small companies which owned and maintained station dc supplies in NERC Protection Systems developed maintenance programs where trending of ohmic measurements of cells/units of the station's battery became the maintenance activity for determining if the station battery could perform as manufactured. By evaluation of the trending

of the ohmic measurements over time, the owner could track the performance of the individual components of the station battery and determine if a total station battery or components of it required capacity testing, removal, replacement or in many instances replacement of the entire station battery. By taking this condition based approach these owners have eliminated having to perform capacity testing at prescribed intervals to determine if a battery needs to be replaced and are still able to effectively determine if a station battery can perform as manufactured.

My VRLA batteries have multiple-cells within an individual battery jar (or unit); how am I expected to comply with the cell-to-cell ohmic measurement requirements on these units that I cannot get to?

Measurement of cell/unit (not all batteries allow access to “individual cells” some “units” or jars may have multiple cells within a jar) internal ohmic values of all types of lead acid batteries where the cells of the battery are not visible is a station dc supply maintenance activity in Table 1-4. In cases where individual cells in a multi-cell unit are inaccessible, an ohmic measurement of the entire unit may be made.

I have a concern about my batteries being used to support additional auxiliary loads beyond my protection control systems in a generation station. Is ohmic measurement testing sufficient for my needs?

While this standard is focused on addressing requirements for Protection Systems, if batteries are used to service other load requirements beyond that of Protection Systems (e.g. pumps, valves, inverter loads), the functional entity may consider additional testing to confirm that the capacity of the battery is sufficient to support all loads.

Why verify voltage?

There are two required maintenance activities associated with verification of dc voltages in Table 1-4. These two required activities are to verify station dc supply voltage and float voltage of the battery charger, and have different maximum maintenance intervals. Both of these voltage verification requirements relate directly to the battery charger maintenance.

The verification of the dc supply voltage is simply an observation of battery voltage to prove that the charger has not been lost or is not malfunctioning; a reading taken from the battery charger panel meter or even SCADA values of the dc voltage could be some of the ways that one could satisfy the requirements. Low battery voltage below float voltage indicates that the battery may be on discharge and, if not corrected, the station battery could discharge down to some extremely low value that will not operate the Protection System. High voltage, close to or above the maximum allowable dc voltage for equipment connected to the station dc supply indicates the battery charger may be malfunctioning by producing high dc voltage levels on the Protection System. If corrective actions are not taken to bring the high voltage down, the dc power supplies and other electronic devices connected to the station dc supply may be damaged. The maintenance activity of verifying the float voltage of the battery charger is not to prove that a charger is lost or producing high voltages on the station dc supply, but rather to prove that the charger is properly floating the battery within the proper voltage limits. As above, there are many ways that this requirement can be met.

Why check for the electrolyte level?

In vented lead-acid (VLA) and nickel-cadmium (NiCad) batteries the visible electrolyte level must be checked as one of the required maintenance activities that must be performed at an interval that is equal to or less than the maximum maintenance interval of Table 1-4. Because the electrolyte level in valve-regulated lead-acid (VRLA) batteries cannot be observed, there is no maintenance activity listed in Table 1-4 of the standard for checking the electrolyte level. Low electrolyte level of any cell of a VLA or NiCad station battery is a condition requiring correction. Typically, the electrolyte level should be returned to an acceptable level for both types of batteries (VLA and NiCad) by adding distilled or other approved-quality water to the cell.

Often people confuse the interval for watering all cells required due to evaporation of the electrolyte in the station battery cells with the maximum maintenance interval required to check the electrolyte level. In many of the modern station batteries, the jar containing the electrolyte is so large with the band between the high and low electrolyte level so wide that normal evaporation which would require periodic watering of all cells takes several years to occur. However, because loss of electrolyte due to cracks in the jar, overcharging of the station battery, or other unforeseen events can cause rapid loss of electrolyte; the shorter maximum maintenance intervals for checking the electrolyte level are required. A low level of electrolyte in a VLA battery cell which exposes the tops of the plates can cause the exposed portion of the plates to accelerated sulfation resulting in loss of cell capacity. Also, in a VLA battery where the electrolyte level goes below the end of the cell withdrawal tube or filling funnel, gasses can exit the cell by the tube instead of the flame arrester and present an explosion hazard.

What are the parameters that can be evaluated in Tables 1-4(a) and 1-4(b)?

The most common parameter that is periodically trended and evaluated by industry today to verify that the station battery can perform as manufactured is internal ohmic cell/unit measurements.

In the mid-1990s, several large and small utilities began developing maintenance and testing programs for Protection System station batteries using a condition based maintenance approach of trending internal ohmic measurements to each station battery cell's baseline value. Battery owners use the data collected from this maintenance activity to determine (1) when a station battery requires a capacity test (instead of performing a capacity test on a predetermined, prescribed interval), (2) when an individual cell or battery unit should be replaced, or (3) based on the analysis of the trended data, if the station battery should be replaced without performing a capacity test.

Other examples of measurable parameters that can be periodically trended and evaluated for lead acid batteries are cell voltage, float current, connection resistance. However, periodically trending and evaluating cell/unit Ohmic measurements are the most common battery/cell parameters that are evaluated by industry to verify a lead acid battery string can perform as manufactured.

Why does it appear that there are two maintenance activities in Table 1-4(b) (for VRLA batteries) that appear to be the same activity and have the same maximum maintenance interval?

There are two different and distinct reasons for doing almost the same maintenance activity at the same interval for valve-regulated lead-acid (VRLA) batteries. The first similar activity for VRLA batteries (Table 1-4(b)) that has the same maximum maintenance interval is to "measure battery cell/unit internal ohmic values." Part of the reason for this activity is because the visual inspection of the cell condition is unavailable for VRLA batteries. Besides the requirement to

measure the internal ohmic measurements of VRLA batteries to determine the internal health of the cell, the maximum maintenance interval for this activity is significantly shorter than the interval for vented lead-acid (VLA) due to some unique failure modes for VRLA batteries. Some of the potential problems that VRLA batteries are susceptible to that do not affect VLA batteries are thermal runaway, cell dry-out, and cell reversal when one cell has a very low capacity.

The other similar activity listed in Table 1-4(b) is “...verify that the station battery can perform as manufactured by evaluating the measured cell/unit measurements indicative of battery performance (e.g. internal ohmic values) against the station battery baseline.” This activity allows an owner the option to choose between this activity with its much shorter maximum maintenance interval or the longer maximum maintenance interval for the maintenance activity to “Verify that the station battery can perform as manufactured by conducting a performance or modified performance capacity test of the entire battery bank.”

For VRLA batteries, there are two drivers for internal ohmic readings. The first driver is for a means to trend battery life. Trending against the baseline of VRLA cells in a battery string is essential to determine the approximate state of health of the battery. Ohmic measurement testing may be used as the mechanism for measuring the battery cells. If all the cells in the string exhibit a consistent trend line and that trend line has not risen above a specific deviation (e.g. 30%) over baseline for impedance tests or below baseline for conductance tests, then a judgment can be made that the battery is still in a reasonably good state of health and able to ‘perform as manufactured.’ It is essential that the specific deviation mentioned above is based on data (test or otherwise) that correlates the ohmic readings for a specific battery/tester combination to the health of the battery. This is the intent of the “perform as manufactured six-month test” at Row 4 on Table 1-4b.

The second big driver is VRLA batteries tendency for thermal runaway. This is the intent of the “thermal runaway test” at Row 2 on Table 1-4b. In order to detect a cell in thermal runaway, you need not necessarily have a formal trending program. When a single cell/unit changes significantly or significantly varies from the other cells (e.g. a doubling of resistance/impedance or a 50% decrease in conductance), there is a high probability that the cell/unit/string needs to be replaced as soon as possible. In other words, if the battery is 10 years old and all the cells have approached a significant change in ohmic values over baseline, then you have a battery which is approaching end of life. You need to get ready to buy a new battery, but you do not have to worry about an impending catastrophic failure. On the other hand, if the battery is five years old and you have one cell that has a markedly different ohmic reading than all the other cells, then you need to be worried that this cell is susceptible to thermal runaway. If the float (charging) current has risen significantly and the ohmic measurement has increased/decreased as described above then concern of catastrophic failure should trigger attention for corrective action.

If an entity elects to use a capacity test rather than a cell ohmic value trending program, this does not eliminate the need to be concerned about thermal runaway – the entity still needs to do the six-month readings and look for cells which are outliers in the string but they need not trend results against the factory/as new baseline. Some entities will not mind the extra administrative burden of having the ongoing trending program against baseline - others would rather just do

the capacity test and not have to trend the data against baseline. Nonetheless, all entities must look for ohmic outliers on a six-month basis.

It is possible to accomplish both tasks listed (trend testing for capability and testing for thermal runaway candidates) with the very same ohmic test. It becomes an analysis exercise of watching the trend from baselines and watching for the oblique cell measurement.

In table 1-4(f) (Exclusions for Protection System Station dc Supply Monitoring Devices and Systems), must all component attributes listed in the table be met before an exclusion can be granted for a maintenance activity?

Table 1-4(f) was created by the drafting team to allow Protection System dc supply owners to obtain exclusions from periodic maintenance activities by using monitoring devices. The basis of the exclusions granted in the table is that the monitoring devices must incorporate the monitoring capability of microprocessor based components which perform continuous self-monitoring. For failure of the microprocessor device used in dc supply monitoring, the self-checking routine in the microprocessor must generate an alarm which will be reported within 24 hours of device failure to a location where corrective action can be initiated.

Table 1-4(f) lists 8 component attributes along with a specific periodic maintenance activity associated with each of the 8 attributes listed. If an owner of a station dc supply wants to be excluded from periodically performing one of the 8 maintenance activities listed in table 1-4(f), the owner must have evidence that the monitoring and alarming component attributes associated with the excluded maintenance activity are met by the self-checking microprocessor based device with the specific component attribute listed in the table 1-4(f).

For example if an owner of a VLA station battery does not want to “verify station dc supply voltage” every “4 calendar months” (see table 1-4(a)), the owner can install a monitoring and alarming device “with high and low voltage monitoring and alarming of the battery charger voltage to detect charger overvoltage and charger failure” and “no periodic verification of station dc supply voltage is required” (see table 1-4(f) first row). However, if for the same Protection System discussed above, the owner does not install “electrolyte level monitoring and alarming in every cell” and “unintentional dc ground monitoring and alarming” (see second and third rows of table 1-4(f)), the owner will have to “inspect electrolyte level and for unintentional grounds” every “4 calendar months” (see table 1-4(a)).

15.5 Associated communications equipment (Table 1-2)

The equipment used for tripping in a communications-assisted trip scheme is a vital piece of the trip circuit. Remote action causing a local trip can be thought of as another parallel trip path to the trip coil that must be tested. Besides the trip output and wiring to the trip coil(s), there is also a communications medium that must be maintained. Newer technologies now exist that achieve communications-assisted tripping without the conventional wiring practices of older technology. For example, older technologies may have included Frequency Shift Key methods. This technology requires that guard and trip levels be maintained. The actual tripping path(s) to the trip coil(s) may be tested as a parallel trip path within the dc control circuitry tests. Emerging technologies transfer digital information over a variety of carrier mediums that are then

interpreted locally as trip signals. The requirements apply to the communicated signal needed for the proper operation of the protective relay trip logic or scheme. Therefore, this standard is applied to equipment used to convey both trip signals (permissive or direct) and block signals.

It was the intent of this standard to require that a test be performed on any communications-assisted trip scheme, regardless of the vintage of technology. The essential element is that the tripping (or blocking) occurs locally when the remote action has been asserted; or that the tripping (or blocking) occurs remotely when the local action is asserted. Note that the required testing can still be done within the concept of testing by overlapping segments. Associated communications equipment can be (but is not limited to) testing at other times and different frequencies as the protective relays, the individual trip paths and the affected circuit interrupting devices.

Some newer installations utilize digital signals over fiber-optics from the protective relays in the control house to the circuit interrupting device in the yard. This method of tripping the circuit breaker, even though it might be considered communications, must be maintained per the dc control circuitry maintenance requirements.

15.5.1 Frequently Asked Questions:

What are some examples of mechanisms to check communications equipment functioning?

For unmonitored Protection Systems, various types of communications systems will have different facilities for on-site integrity checking to be performed at least every four months during a substation visit. Some examples are, but not limited to:

- On-off power-line carrier systems can be checked by performing a manual carrier keying test between the line terminals, or carrier check-back test from one terminal.
- Systems which use frequency-shift communications with a continuous guard signal (over a telephone circuit, analog microwave system, etc.) can be checked by observing for a loss-of-guard indication or alarm. For frequency-shift power-line carrier systems, the guard signal level meter can also be checked.
- Hard-wired pilot wire line Protection Systems typically have pilot-wire monitoring relays that give an alarm indication for a pilot wire ground or open pilot wire circuit loop.
- Digital communications systems typically have a data reception indicator or data error indicator (based on loss of signal, bit error rate, or frame error checking).

For monitored Protection Systems, various types of communications systems will have different facilities for monitoring the presence of the communications channel, and activating alarms that can be monitored remotely. Some examples are, but not limited to:

- On-off power-line carrier systems can be shown to be operational by automated periodic power-line carrier check-back tests with remote alarming of failures.
- Systems which use a frequency-shift communications with a continuous guard signal (over a telephone circuit, analog microwave system, etc.) can be remotely monitored with a loss-of-guard alarm or low signal level alarm.
- Hard-wired pilot wire line Protection Systems can be monitored by remote alarming of pilot-wire monitoring relays.
- Digital communications systems can activate remotely monitored alarms for data reception loss or data error indications.
- Systems can be queried for the data error rates.

For the highest degree of monitoring of Protection Systems, the communications system must monitor all aspects of the performance and quality of the channel that show it meets the design performance criteria, including monitoring of the channel interface to protective relays.

- In many communications systems signal quality measurements, including signal-to-noise ratio, received signal level, reflected transmitter power or standing wave ratio, propagation delay, and data error rates are compared to alarm limits. These alarms are connected for remote monitoring.
- Alarms for inadequate performance are remotely monitored at all times, and the alarm communications system to the remote monitoring site must itself be continuously monitored to assure that the actual alarm status at the communications equipment location is continuously being reflected at the remote monitoring site.

What is needed for the four-month inspection of communications-assisted trip scheme equipment?

The four-month inspection applies to unmonitored equipment. An example of compliance with this requirement might be, but is not limited to:

With each site visit, check that the equipment is free from alarms; check any metered signal levels, and that power is still applied. While this might be explicit for a particular type of equipment (i.e., FSK equipment), the concept should be that the entity verify that the communications equipment that is used in a Protection System is operable through a cursory inspection and site visit. This site visit can be eliminated on this particular example if the FSK equipment had a monitored alarm on Loss of Guard. Blocking carrier systems with auto checkbacks will present an alarm when the channel fails allowing a visual indication. With no auto checkback, the channel integrity will need to be verified by a manual checkback or a two ended signal check. This check could also be eliminated by bring the auto checkback failure alarm to the monitored central location.

Does a fiber optic I/O scheme used for breaker tripping or control within a station, for example - transmitting a trip signal or control logic between the control house and the breaker control cabinet, constitute a communications system?

This equipment is presently classified as being part of the Protection System control circuitry and tested per the portions of Table 1 applicable to “Protection System Control Circuitry”, rather than those portions of the table applicable to communications equipment.

What is meant by “Channel” and “Communications Systems” in Table 1-2?

The transmission of logic or data from a relay in one station to a relay in another station for use in a pilot relay scheme will require a communications system of some sort. Typical relay communications systems use fiber optics, leased audio channels, power line carrier, and microwave. The overall communications system includes the channel and the associated communications equipment.

This standard refers to the “channel” as the medium between the transmitters and receivers in the relay panels such as a leased audio or digital communications circuit, power line and power line carrier auxiliary equipment, and fiber. The dividing line between the channel and the associated communications equipment is different for each type of media.

Examples of the Channel:

- Power Line Carrier (PLC) - The PLC channel starts and ends at the PLC transmitter and receiver output unless there is an internal hybrid. The channel includes the external hybrids, tuners, wave traps and the power line itself.
- Microwave –The channel includes the microwave multiplexers, radios, antennae and associated auxiliary equipment. The audio tone and digital transmitters and receivers in the relay panel are the associated communications equipment.
- Digital/Audio Circuit – The channel includes the equipment within and between the substations. The associated communications equipment includes the relay panel transmitters and receivers and the interface equipment in the relays.

-
- Fiber Optic – The channel starts at the fiber optic connectors on the fiber distribution panel at the local station and goes to the fiber optic distribution panel at the remote substation. The jumpers that connect the relaying equipment to the fiber distribution panel and any optical-electrical signal format converters are the associated communications equipment

Figure 1-2, A-1 and A-2 at the end of this document show good examples of the communications channel and the associated communications equipment.

In Table 1-2, the Maintenance Activities section of the Protection System Communications Equipment and Channels refers to the quality of the channel meeting “performance criteria.” What is meant by performance criteria?

Protection System communications channels must have a means of determining if the channel and communications equipment is operating normally. If the channel is not operating normally, an alarm will be indicated. For unmonitored systems, this alarm will probably be on the panel. For monitored systems, the alarm will be transmitted to a remote location.

Each entity will have established a nominal performance level for each Protection System communications channel that is consistent with proper functioning of the Protection System. If that level of nominal performance is not being met, the system will go into alarm. Following are some examples of Protection System communications channel performance measuring:

- For direct transfer trip using a frequency shift power line carrier channel, a guard level monitor is part of the equipment. A normal receive level is established when the system is calibrated and if the signal level drops below an established level, the system will indicate an alarm.
- An on-off blocking signal over power line carrier is used for directional comparison blocking schemes on transmission lines. During a Fault, block logic is sent to the remote relays by turning on a local transmitter and sending the signal over the power line to a receiver at the remote end. This signal is normally off so continuous levels cannot be checked. These schemes use check-back testing to determine channel performance. A predetermined signal sequence is sent to the remote end and the remote end decodes this signal and sends a signal sequence back. If the sending end receives the correct information from the remote terminal, the test passes and no alarm is indicated. Full power and reduced power tests are typically run. Power levels for these tests are determined at the time of calibration.
- Pilot wire relay systems use a hardwire communications circuit to communicate between the local and remote ends of the protective zone. This circuit is monitored by circulating a dc current between the relay systems. A typical level may be 1 mA. If the level drops below the setting of the alarm monitor, the system will indicate an alarm.
- Modern digital relay systems use data communications to transmit relay information to the remote end relays. An example of this is a line current differential scheme commonly used on transmission lines. The protective relays communicate current magnitude and phase information over the communications path to determine if the Fault is located in the protective zone. Quantities such as digital packet loss, bit error rate and channel delay are monitored to determine the quality of the channel. These limits are determined and

set during relay commissioning. Once set, any channel quality problems that fall outside the set levels will indicate an alarm.

The previous examples show how some protective relay communications channels can be monitored and how the channel performance can be compared to performance criteria established by the entity. This standard does not state what the performance criteria will be; it just requires that the entity establish nominal criteria so Protection System channel monitoring can be performed.

How is the performance criteria of Protection System communications equipment involved in the maintenance program?

An entity determines the acceptable performance criteria, depending on the technology implemented. If the communications channel performance of a Protection System varies from the pre-determined performance criteria for that system, then these results should be investigated and resolved.

How do I verify the A/D converters of microprocessor-based relays?

There are a variety of ways to do this. Two examples would be: using values gathered via data communications and automatically comparing these values with values from other sources, or using groupings of other measurements (such as vector summation of bus feeder currents) for comparison. Many other methods are possible.

15.6 Alarms (Table 2)

In addition to the tables of maintenance for the components of a Protection System, there is an additional table added for alarms. This additional table was added for clarity. This enabled the common alarm attributes to be consolidated into a single spot, and, thus, make it easier to read the Tables 1-1 through 1-5, Table 3, and Table 4. The alarms need to arrive at a site wherein a corrective action can be initiated. This could be a control room, operations center, etc. The alarming mechanism can be a standard alarming system or an auto-polling system; the only requirement is that the alarm be brought to the action-site within 24 hours. This effectively makes manned-stations equivalent to monitored stations. The alarm of a monitored point (for example a monitored trip path with a lamp) in a manned-station now makes that monitored point eligible for monitored status. Obviously, these same rules apply to a non-manned-station, which is that if the monitored point has an alarm that is auto-reported to the operations center (for example) within 24 hours, then it too is considered monitored.

15.6.1 Frequently Asked Questions:

Why are there activities defined for varying degrees of monitoring a Protection System component when that level of technology may not yet be available?

There may already be some equipment available that is capable of meeting the highest levels of monitoring criteria listed in the Tables. However, even if there is no equipment available today that can meet this level of monitoring the standard establishes the necessary requirements for when such equipment becomes available. By creating a roadmap for development, this provision makes the standard technology neutral. The Standard Drafting Team wants to avoid the need to revise the standard in a few years to accommodate technology advances that may be coming to the industry.

Does a fail-safe “form b” contact that is alarmed to a 24/7 operation center classify as an alarm path with monitoring?

If the fail-safe “form-b” contact that is alarmed to a 24/7 operation center causes the alarm to activate for failure of any portion of the alarming path from the alarm origin to the 24/7 operations center, then this can be classified as an alarm path with monitoring.

15.7 Distributed UFLS and Distributed UVLS Systems (Table 3)

Distributed UFLS and distributed UVLS systems have their maintenance activities documented in Table 3 due to their distributed nature allowing reduced maintenance activities and extended maximum maintenance intervals. Relays have the same maintenance activities and intervals as Table 1-1. Voltage and current-sensing devices have the same maintenance activity and interval as Table 1-3. DC systems need only have their voltage read at the relay every 12 years. Control circuits have the following maintenance activities every 12 years:

- Verify the trip path between the relay and lock-out and/or auxiliary tripping device(s).
- Verify operation of any lock-out and/or auxiliary tripping device(s) used in the trip circuit.
- No verification of trip path required between the lock-out (and/or auxiliary tripping device) and the non-BES interrupting device.
- No verification of trip path required between the relay and trip coil for circuits that have no lock-out and/or auxiliary tripping device(s).
- No verification of trip coil required.

No maintenance activity is required for associated communication systems for distributed UFLS and distributed UVLS schemes.

Non-BES interrupting devices that participate in a distributed UFLS or distributed UVLS scheme are excluded from the tripping requirement, and part of the control circuit test requirement; however, the part of the trip path control circuitry between the Load-Shed relay and lock-out or auxiliary tripping relay must be tested at least once every 12 years. In the case where there is no lock-out or auxiliary tripping relay used in a distributed UFLS or UVLS scheme which is not part of the BES, there is no control circuit test requirement. There are many circuit interrupting devices in the distribution system that will be operating for any given under-frequency event that requires tripping for that event. A failure in the tripping action of a single distributed system circuit breaker (or non-BES equipment interruption device) will be far less significant than, for example, any single transmission Protection System failure, such as a failure of a bus differential lock-out relay. While many failures of these distributed system circuit breakers (or non-BES equipment interruption device) could add up to be significant, it is also believed that many circuit breakers are operated often on just Fault clearing duty; and, therefore, these circuit breakers are operated at least as frequently as any requirements that appear in this standard.

There are times when a Protection System component will be used on a BES device, as well as a non-BES device, such as a battery bank that serves both a BES circuit breaker and a non-BES interrupting device used for UFLS. In such a case, the battery bank (or other Protection System component) will be subject to the Tables of the standard because it is used for the BES.

15.7.1 Frequently Asked Questions:

The standard reaches further into the distribution system than we would like for UFLS and UVLS

While UFLS and UVLS equipment are located on the distribution network, their job is to protect the Bulk Electric System. This is not beyond the scope of NERC's 215 authority.

FPA section 215(a) definitions section defines bulk power system as: "(A) facilities and control Systems necessary for operating an interconnected electric energy transmission network (or any portion thereof)." That definition, then, is limited by a later statement which adds the term bulk power system "...does not include facilities used in the local distribution of electric energy." Also, Section 215 also covers users, owners, and operators of bulk power Facilities.

UFLS and UVLS (when the UVLS is installed to prevent system voltage collapse or voltage instability for BES reliability) are not "used in the local distribution of electric energy," despite their location on local distribution networks. Further, if UFLS/UVLS Facilities were not covered by the reliability standards, then in order to protect the integrity of the BES during under-frequency or under-voltage events, that Load would have to be shed at the Transmission bus to ensure the Load-generation balance and voltage stability is maintained on the BES.

15.8 Automatic Reclosing (Table 4)

Please see the document referenced in Section F of PRC-005-3, "Considerations for Maintenance and Testing of Autoreclosing Schemes — November 2012", for a discussion of Automatic Reclosing as addressed in PRC-005-3.

15.8.1 Frequently-asked Questions

Automatic Reclosing is a control, not a protective function; why then is Automatic Reclosing maintenance included in the Protection System Maintenance Program (PSMP)?

Automatic Reclosing is a control function. The standard's title 'Protection System and Automatic Reclosing Maintenance' clearly distinguishes (separates) the Automatic Reclosing from the Protection System. Automatic Reclosing is included in the PSMP because it is a more pragmatic approach as compared to creating a parallel and essentially identical 'Control System Maintenance Program' for the two Automatic Reclosing component types.

When do I need to have the initial maintenance of Automatic Reclosing Components completed upon change of the largest BES generating unit in the BA/RSG?

The maintenance interval, for newly identified Automatic Reclosing Components, starts when a change in the largest BES generating unit is determined by the BA/RSG. The first maintenance records for newly identified Automatic Reclosing Components should be dated no later than the maximum maintenance interval after the identification date. The maximum maintenance intervals for each newly identified Component are defined in Table 4. No activities or records are required prior to the date of identification.

Our maintenance practice consists of initiating the Automatic Reclosing relay and confirming the breaker closes properly and the close signal is released. This practice verifies the control circuitry associated with Automatic Reclosing. Do you agree?"

The described task partially verifies the control circuit maintenance activity. To meet the control circuit maintenance activity, responsible entities need to verify, *upon initiation*, that the reclosing relay does not issue a *premature closing command*. As noted on page 12 of the SAMS/SPCS report, the concern being addressed within the standard is premature auto reclosing that has the potential to cause generating unit or plant instability. Reclosing applications have many variations, responsible entities will need to verify the applicability of associated supervision/conditional logic and the reclosing relay operation; then verify the conditional logic or that the reclosing relay performs in a manner that does not result in a *premature closing command* being issued.

Some examples of conditions which can result in a premature closing command are: an improper supervision or conditional logic input which provides a false state and allows the reclosing relay to issue an improper close command based on incorrect conditions (i.e. voltage supervision, equipment status, sync window verification); timers utilized for closing actuation or reclosing arming/disarming circuitry which could allow the reclosing relay to issue an improper close command; a reclosing relay output contact failure which could result in a made-up-close condition / failure-to-release condition.

Why was a close-in three phase fault present for twice the normal clearing time chosen for the Automatic Reclosing exclusion? It exceeds TPL requirements and ignores the breaker closing time in a trip-close-trip sequence, thus making the exclusion harder to attain.

This condition represents a situation where a close signal is issued with no time delay or with less time delay than is intended, such as if a reclosing contact is welded closed. This failure mode can result in a minimum trip-close-trip sequence with the two faults cleared in primary protection operating time, and the open time between faults equal to the breaker closing cycle time. The sequence for this failure mode results in system impact equivalent to a high-speed autoreclosing sequence with no delay added in the autoreclosing logic. It represents a failure mode which must be avoided because it exceeds TPL requirements.

Do we have to test the various breaker closing circuit interlocks and controls such as anti-pump?

These components are not specifically addressed within Table 4, and need not be individually tested. They are indirectly verified by performing the Automatic Reclosing control circuitry verification as established in Table 4.

For Automatic Reclosing that is not part of an RAS, do we have to close the circuit breaker periodically?

No. For this application, you need only to verify that the Automatic Reclosing, upon initiation, does not issue a premature closing command. This activity is concerned only with assuring that a premature close does not occur, and cause generating plant instability.

For Automatic Reclosing that is part of an RAS, do we have to close the circuit breaker periodically?

Yes. In this application, successful closing is a necessary portion of the RAS, and must be verified.

Why is maintenance of supervisory relays now included in PRC-005 for Automatic Reclosing?

Proper performance of supervising relays supports the reliability of the BES because some conditions can result in a premature closing command. -An example of this would be an improper supervision or conditional logic input which provides a false state and allows the reclosing relay to issue an improper close command based on incorrect conditions (i.e. voltage supervision, sync window verification)

My reclosing circuitry contains the following inputs listed below: what supervising relays would need to be tested per PRC-005?:

- 79/ON – Supervisory contact which turns Automatic reclosing ON or OFF
- 52 – Supervisory contact which provides breaker indication (“b” contact)
- 86 - Supervisory contact from a lockout relay
- 79 – Supervisory contact from a reclosing relay
- 25 – Supervisory contact from a sync-check relay
- 27 or 59 – Supervisory contact from a undervoltage of overvoltage relay

Supervising Relays are defined in this standard as “relay(s) that perform voltage and/or sync check functions that enables or disables operation of the reclosing relay.” The 79/ON, 52, and 86 would not need to be included. However, the 79, 25, and 27 or 59 would be included because they are supervisory devices that are either associated with autoreclosing, sync-checks, and/or voltage.

The sync check and voltage check functions are part of my microprocessor reclosing relay. Are there any test requirements for these internal supervisory functions?

A microprocessor reclosing relay that is using internal sync check or voltage check supervisory functions is a combinational reclosing and supervisory relay (i.e. 79/25)-. The maintenance activities for both a reclosing relay and supervisory relay would apply. The voltage sensing devices providing input to a combinational reclosing and supervisory relay would require the activities in Table 4-3.

Is it necessary to verify the close signal operates the breaker?

Only when the control circuitry associated with automatic reclosing is a part of a RAS, then all paths that are essential for proper operation of the RAS must be verified, per table 4-2(b).

15.9 Sudden Pressure Relaying (Table 5)

Please see the document referenced in Section F of PRC-005-4, “Sudden Pressure Relays and Other Devices that Respond to Non-Electrical Quantities – December 2013”, for a discussion of Sudden Pressure Relaying as addressed in PRC-005-4.

15.9.1 Frequently Asked Questions:

How do I verify the pressure or flow sensing mechanism is operable?

Maintenance activities for the fault pressure relay associated with Sudden Pressure Relaying in PRC-005-4 are intended to verify that the pressure and/or flow sensing mechanism are functioning correctly. Beyond this, PRC-005-4 requires no calibration (adjusting the operating threshold or measurement accuracy of a measuring element to meet the intended performance requirement) or testing (applying signals to a component to observe functional performance or output behavior, or to diagnose problems) activities. For example, some designs of flow sensing mechanisms allow the operation of a test switch to actuate the limit switch of the flow sensing mechanism. Operation of this test switch and verification of the flow sensing mechanism would meet the requirements of the maintenance activity. Another example involves a gas pressure sensing mechanism which is isolated by a test plug. Removal of the plug and verification of the bellows mechanism would meet the requirements of the maintenance activity.

Why the 6-year maximum maintenance interval for fault pressure relays?

The SDT established the six-year maintenance interval for fault pressure relays (see Table 5, PRC-005-4) based on the recommendation of the System Protection and Control Subcommittee (SPCS). The technical experts of the SPCS were tasked with developing the technical documents to:

- i. Describe the devices and functions (to include sudden pressure relays which trip for fault conditions) that should address FERC's concern; and
- ii. Propose minimum maintenance activities for such devices and maximum maintenance intervals, including the technical basis for each.

Excerpt from the [SPCS technical report](#): "In order to determine present industry practices related to sudden pressure relay maintenance, the SPCS conducted a survey of Transmission Owners and Generator Owners in all eight Regions requesting information related to their maintenance practices. The SPCS received responses from 75 Transmission Owners and 109 Generator Owners. Note that, for the purpose of the survey, sudden pressure relays included the following: the "sudden pressure relay" (SPR) originally manufactured by Westinghouse, the "rapid pressure rise relay" (RPR) manufactured by Qualitrol, and a variety of Buchholz relays.

Table 2 provides a summary of the results of the responses:

Table 2: Sudden Pressure Relay Maintenance Practices – Survey Results		
	Transmission Owner	Generator Owner
Number of responding owners that trip with Sudden Pressure Relays:	67	84
Percentage of responding owners who trip that have a Maintenance Program:	75%	78%
Percentage of maintenance programs that include testing the pressure actuator:	81%	77%

Average Maintenance interval reported:	5.9 years	4.9 years
--	-----------	-----------

Additionally, in order to validate the information noted above, the SPCS contacted the following entities for their feedback: the IEEE Power System Relaying Committee, the IEEE Transformer Committee, the Doble Transformer Committee, the NATF System Protection Practices Group, and the EPRI Generator Owner/Operator Technical Focus Group. All of these organizations indicated the results of the SPCS survey are consistent with their respective experiences.

The SPCS discussed the potential difference between the recommended intervals for fault pressure relaying and intervals for transformer maintenance. The SPCS developed the recommended intervals for fault pressure relaying by comparing fault pressure relaying to Protection System Components with similar physical attributes. The SPCS recognized that these intervals may be shorter than some existing or future transformer maintenance intervals, but believed it to be more important to base intervals for fault pressure relaying on similar Protection System Components than transformer maintenance intervals.

The maintenance interval for fault pressure relays can be extended by utilizing performance-based maintenance thereby allowing entities that have maintenance intervals for transformers in excess of six years, to align them.

Sudden Pressure Relaying control circuitry is now specifically mentioned in the maintenance tables. Do we have to trip our circuit breaker specifically from the trip output of the sudden pressure relay?

No. Verification may be by breaker tripping, but may be verified in overlapping segments with the Protection System control circuitry.

Can we use Performance Based Maintenance for fault pressure relays?

Yes. Performance Based Maintenance is applicable to fault pressure relays.

15.10 Examples of Evidence of Compliance

To comply with the requirements of this standard, an entity will have to document and save evidence. The evidence can be of many different forms. The Standard Drafting Team recognizes that there are concurrent evidence requirements of other NERC standards that could, at times, fulfill evidence requirements of this standard.

15.10.1 Frequently Asked Questions:

What forms of evidence are acceptable?

Acceptable forms of evidence, as relevant for the requirement being documented include, but are not limited to:

- Process documents or plans
- Data (such as relay settings sheets, photos, SCADA, and test records)
- Database lists, records and/or screen shots that demonstrate compliance information
- Prints, diagrams and/or schematics
- Maintenance records

-
- Logs (operator, substation, and other types of log)
 - Inspection forms
 - Mail, memos, or email proving the required information was exchanged, coordinated, submitted or received
 - Check-off forms (paper or electronic)
 - Any record that demonstrates that the maintenance activity was known, accounted for, and/or performed.

If I replace a failed Protection System component with another component, what testing do I need to perform on the new component?

In order to reset the Table 1 maintenance interval for the replacement component, all relevant Table 1 activities for the component should be performed.

I have evidence to show compliance for PRC-016 (“Special Protection System Misoperation”). Can I also use it to show compliance for this Standard, PRC-005-4?

Maintaining evidence for operation of Remedial Action Schemes could concurrently be utilized as proof of the operation of the associated trip coil (provided one can be certain of the trip coil involved). Thus, the reporting requirements that one may have to do for the Misoperation of a Special Protection Scheme under PRC-016 could work for the activity tracking requirements under this PRC-005-4.

I maintain Disturbance records which show Protection System operations. Can I use these records to show compliance?

These records can be concurrently utilized as dc trip path verifications, to the degree that they demonstrate the proper function of that dc trip path.

I maintain test reports on some of my Protection System components. Can I use these test reports to show that I have verified a maintenance activity?

Yes. References

1. [Protection System Maintenance: A Technical Reference](#). Prepared by the System Protection and Controls Task Force of the NERC Planning Committee. Dated September 13, 2007.
2. “Predicating The Optimum Routine test Interval For Protection Relays,” by J. J. Kumm, M.S. Weber, D. Hou, and E. O. Schweitzer, III, IEEE Transactions on Power Delivery, Vol. 10, No. 2, April 1995.
3. “Transmission Relay System Performance Comparison For 2000, 2001, 2002, 2003, 2004 and 2005,” Working Group I17 of Power System Relaying Committee of IEEE Power Engineering Society, May 2006.
4. “A Survey of Relaying Test Practices,” Special Report by WG I11 of Power System Relaying Committee of IEEE Power Engineering Society, September 16, 1999.
5. “Transmission Protective Relay System Performance Measuring Methodology,” Working Group I3 of Power System Relaying Committee of IEEE Power Engineering Society, January 2002.

-
6. "Processes, Issues, Trends and Quality Control of Relay Settings," Working Group C3 of Power System Relaying Committee of IEEE Power Engineering Society, December 2006.
 7. "Proposed Statistical Performance Measures for Microprocessor-Based Transmission-Line Protective Relays, Part I - Explanation of the Statistics, and Part II - Collection and Uses of Data," Working Group D5 of Power System Relaying Committee of IEEE Power Engineering Society, May 1995; Papers 96WM 016-6 PWRD and 96WM 127-1 PWRD, 1996 IEEE Power Engineering Society Winter Meeting.
 8. "Analysis And Guidelines For Testing Numerical Protection Schemes," Final Report of CIGRE WG 34.10, August 2000.
 9. "Use of Preventative Maintenance and System Performance Data to Optimize Scheduled Maintenance Intervals," H. Anderson, R. Loughlin, and J. Zipp, Georgia Tech Protective Relay Conference, May 1996.
 10. "Battery Performance Monitoring by Internal Ohmic Measurements" EPRI Application Guidelines for Stationary Batteries TR- 108826 Final Report, December 1997.
 11. "IEEE Recommended Practice for Maintenance, Testing, and Replacement of Valve-Regulated Lead-Acid (VRLA) Batteries for Stationary Applications," IEEE Power Engineering Society Std 1188 – 2005.
 12. "IEEE Recommended Practice for Maintenance, Testing, and Replacement of Vented Lead-Acid Batteries for Stationary Applications," IEEE Power & Engineering Society Std 45-2010.
 13. "IEEE Recommended Practice for Installation design and Installation of Vented Lead-Acid Batteries for Stationary Applications," IEEE Std 484 – 2002.
 14. "Stationary Battery Monitoring by Internal Ohmic Measurements," EPRI Technical Report, 1002925 Final Report, December 2002.
 15. "Stationary Battery Guide: Design Application, and Maintenance" EPRI Revision 2 of TR-100248, 1006757, August 2002.

PSMT SDT References

16. "Essentials of Statistics for Business and Economics" Anderson, Sweeney, Williams, 2003
17. "Introduction to Statistics and Data Analysis" - Second Edition, Peck, Olson, Devore, 2005
18. "Statistical Analysis for Business Decisions" Peters, Summers, 1968
19. "Considerations for Maintenance and Testing of Autoreclosing Schemes," NERC System Analysis and Modeling Subcommittee and NERC System Protection and Control Subcommittee, November 2012

Figures

Figure 1: Typical Transmission System

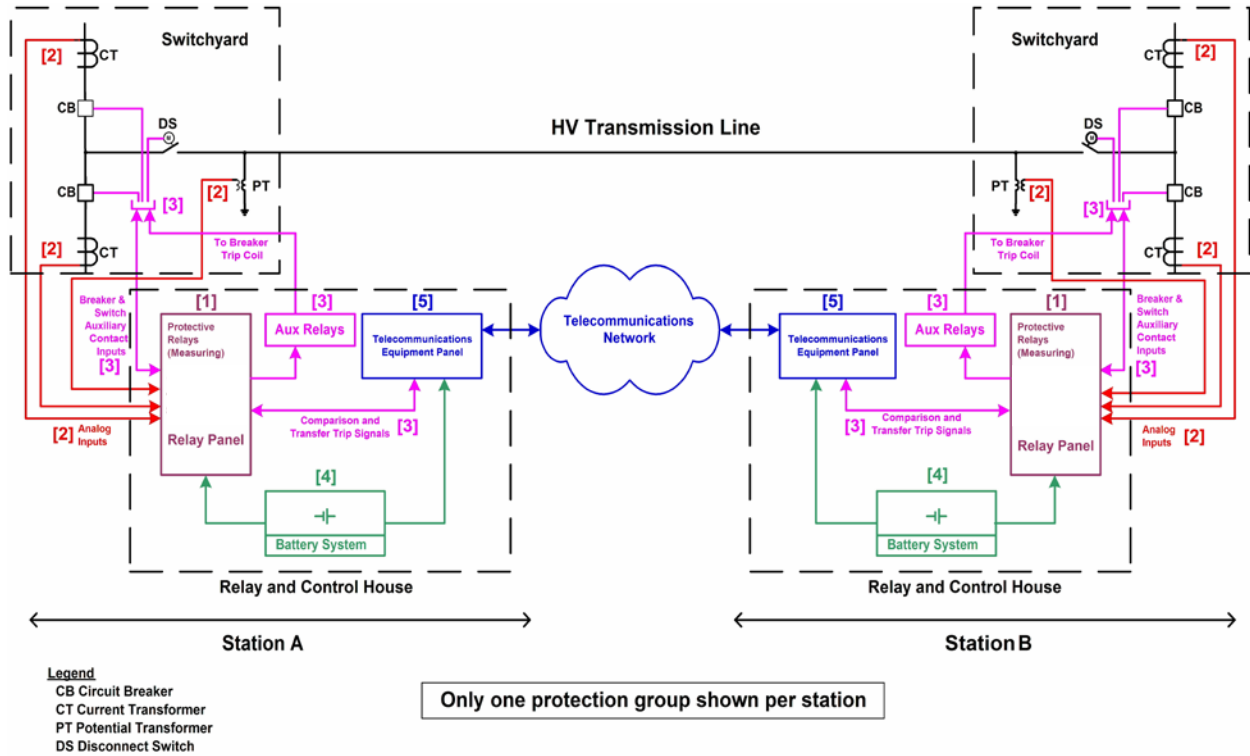

For information on components, see [Figure 1 & 2 Legend – components of Protection Systems](#)

Figure 2: Typical Generation System

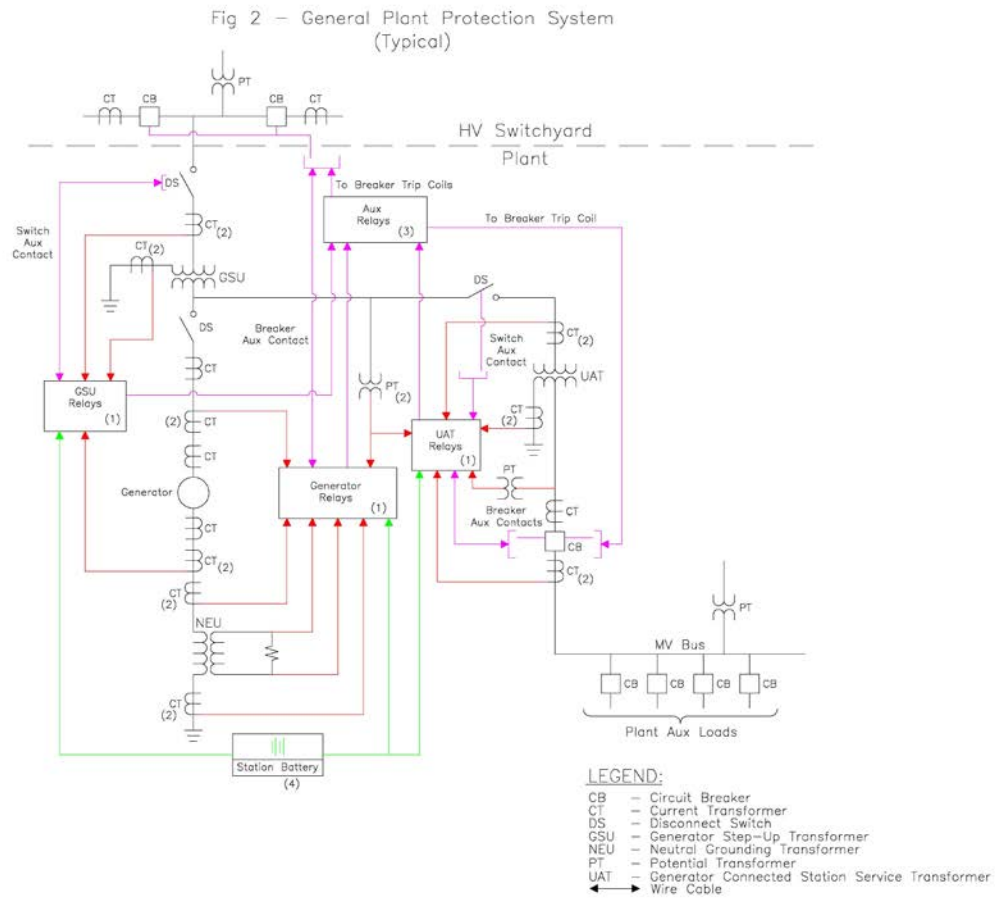

Note: Figure 2 may show elements that are not included within PRC-005-2, and also may not be all-inclusive; see the Applicability section of the standard for specifics.

For information on components, see [Figure 1 & 2 Legend – components of Protection Systems](#)

Figure 1 & 2 Legend – Components of Protection Systems

Number in Figure	Component of Protection System	Includes	Excludes
1	Protective relays which respond to electrical quantities	All protective relays that use current and/or voltage inputs from current & voltage sensors and that trip the 86, 94 or trip coil.	Devices that use non-electrical methods of operation including thermal, pressure, gas accumulation, and vibration. Any ancillary equipment not specified in the definition of Protection Systems. Control and/or monitoring equipment that is not a part of the automatic tripping action of the Protection System
2	Voltage and current sensing devices providing inputs to protective relays	The signals from the voltage & current sensing devices to the protective relay input.	Voltage & current sensing devices that are not a part of the Protection System, including sync-check systems , metering systems and data acquisition systems.
3	Control circuitry associated with protective functions	All control wiring (or other medium for conveying trip signals) associated with the tripping action of 86 devices, 94 devices or trip coils (from all parallel trip paths). This would include fiber-optic systems that carry a trip signal as well as hard-wired systems that carry trip current.	Closing circuits, SCADA circuits, other devices in control scheme not passing trip current
4	Station dc supply	Batteries and battery chargers and any control power system which has the function of supplying power to the protective relays, associated trip circuits and trip coils.	Any power supplies that are not used to power protective relays or their associated trip circuits and trip coils.
5	Communications systems necessary for correct operation of protective functions	Tele-protection equipment used to convey specific information, in the form of analog or digital signals, necessary for the correct operation of protective functions.	Any communications equipment that is not used to convey information necessary for the correct operation of protective functions.

[Additional information can be found in References](#)

Appendix A

The following illustrates the concept of overlapping verifications and tests as summarized in Section 10 of the paper. As an example, Figure A-1 shows protection for a critical transmission line by carrier blocking directional comparison pilot relaying. The goal is to verify the ability of the entire two-terminal pilot protection scheme to protect for line faults, and to avoid over-tripping for faults external to the transmission line zone of protection bounded by the current transformer locations.

Figure A-1

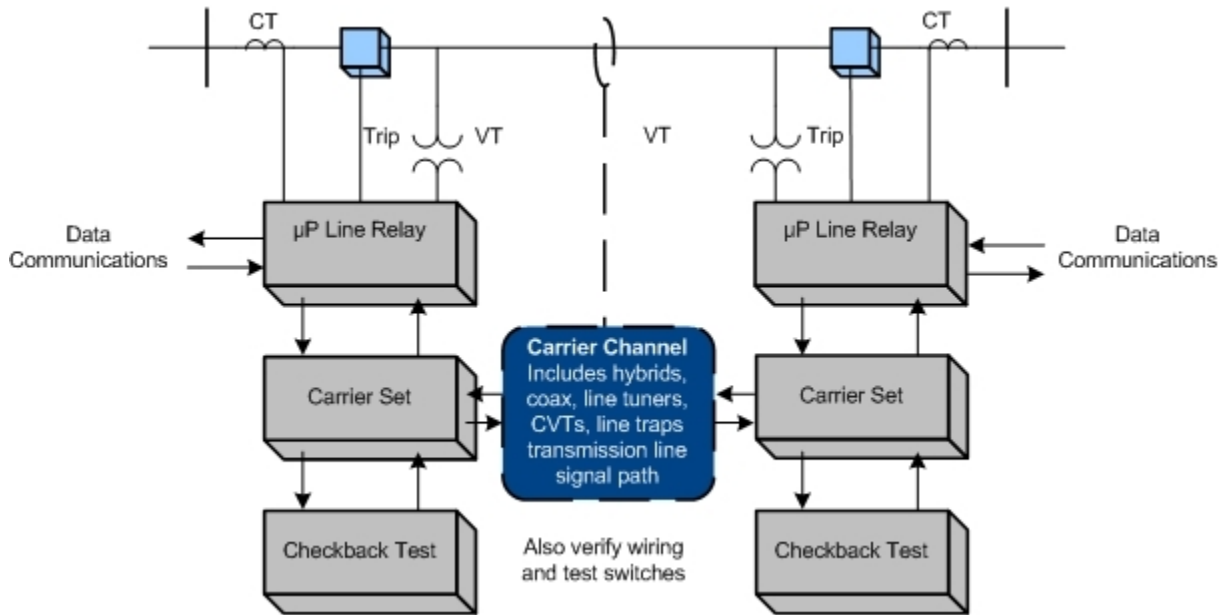

In this example (Figure A1), verification takes advantage of the self-monitoring features of microprocessor multifunction line relays at each end of the line. For each of the line relays themselves, the example assumes that the user has the following arrangements in place:

1. The relay has a data communications port that can be accessed from remote locations.
2. The relay has internal self-monitoring programs and functions that report failures of internal electronics, via communications messages or alarm contacts to SCADA.
3. The relays report loss of dc power, and the relays themselves or external monitors report the state of the dc battery supply.
4. The CT and PT inputs to the relays are used for continuous calculation of metered values of volts, amperes, plus Watts and VARs on the line. These metered values are reported by data communications. For maintenance, the user elects to compare these readings to those of other relays, meters, or DFRs. The other readings may be from redundant relaying or measurement systems or they may be derived from values in other protection zones. Comparison with other such readings to within required relaying accuracy verifies voltage & current sensing devices, wiring, and analog signal input processing of the relays. One

effective way to do this is to utilize the relay metered values directly in SCADA, where they can be compared with other references or state estimator values.

5. Breaker status indication from auxiliary contacts is verified in the same way as in (2). Status indications must be consistent with the flow or absence of current.
6. Continuity of the breaker trip circuit from dc bus through the trip coil is monitored by the relay and reported via communications.
7. Correct operation of the on-off carrier channel is also critical to security of the Protection System, so each carrier set has a connected or integrated automatic checkback test unit. The automatic checkback test runs several times a day. Newer carrier sets with integrated checkback testing check for received signal level and report abnormal channel attenuation or noise, even if the problem is not severe enough to completely disable the channel.

These monitoring activities plus the check-back test comprise automatic verification of all the Protection System elements that experience tells us are the most prone to fail. But, does this comprise a complete verification?

Figure A-2

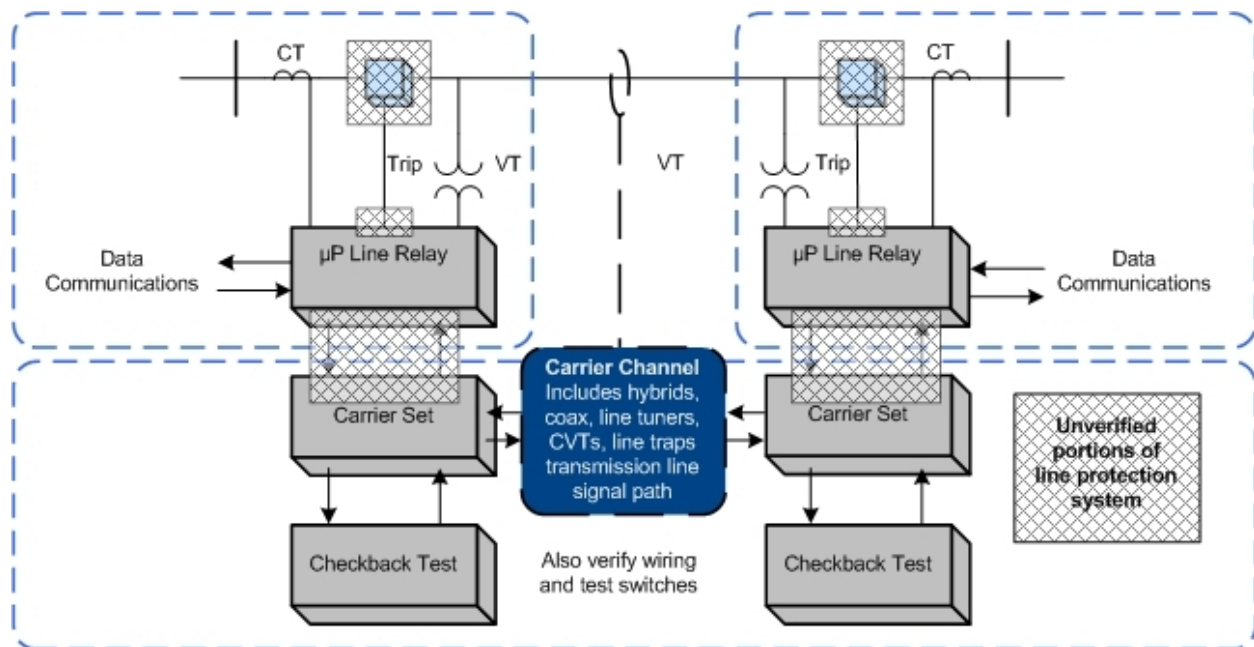

The dotted boxes of Figure A-2 show the sections of verification defined by the monitoring and verification practices just listed. These sections are not completely overlapping, and the shaded regions show elements that are not verified:

1. The continuity of trip coils is verified, but no means is provided for validating the ability of the circuit breaker to trip if the trip coil should be energized.

-
2. Within each line relay, all the microprocessors that participate in the trip decision have been verified by internal monitoring. However, the trip circuit is actually energized by the contacts of a small telephone-type "ice cube" relay within the line protective relay. The microprocessor energizes the coil of this ice cube relay through its output data port and a transistor driver circuit. There is no monitoring of the output port, driver circuit, ice cube relay, or contacts of that relay. These components are critical for tripping the circuit breaker for a Fault.
 3. The check-back test of the carrier channel does not verify the connections between the relaying microprocessor internal decision programs and the carrier transmitter keying circuit or the carrier receiver output state. These connections include microprocessor I/O ports, electronic driver circuits, wiring, and sometimes telephone-type auxiliary relays.
 4. The correct states of breaker and disconnect switch auxiliary contacts are monitored, but this does not confirm that the state change indication is correct when the breaker or switch opens.

A practical solution for (1) and (2) is to observe actual breaker tripping, with a specified maximum time interval between trip tests. Clearing of naturally-occurring Faults are demonstrations of operation that reset the time interval clock for testing of each breaker tripped in this way. If Faults do not occur, manual tripping of the breaker through the relay trip output via data communications to the relay microprocessor meets the requirement for periodic testing.

PRC-005-4 does not address breaker maintenance, and its Protection System test requirements can be met by energizing the trip circuit in a test mode (breaker disconnected) through the relay microprocessor. This can be done via a front-panel button command to the relay logic, or application of a simulated Fault with a relay test set. However, utilities have found that breakers often show problems during Protection System tests. It is recommended that Protection System verification include periodic testing of the actual tripping of connected circuit breakers.

Testing of the relay-carrier set interface in (3) requires that each relay key its transmitter, and that the other relay demonstrate reception of that blocking carrier. This can be observed from relay or DFR records during naturally occurring Faults, or by a manual test. If the checkback test sequence were incorporated in the relay logic, the carrier sets and carrier channel are then included in the overlapping segments monitored by the two relays, and the monitoring gap is completely eliminated.

Appendix B

Protection System Maintenance Standard Drafting Team

Charles W. Rogers
Chairman
Consumers Energy Co.

John B. Anderson
Xcel Energy

~~Stephen Crutchfield~~~~Al McMeekin~~
NERC

~~Merle Ashton~~
~~Tri-State G&T~~

~~Michael Palusso~~
~~Southern California Edison~~

Forrest Brock
Western Farmers Electric Cooperative

John Schecter
American Electric Power

Aaron Feathers
Pacific Gas and Electric Company

William D. Shultz
Southern Company Generation

Sam Francis
Oncor Electric Delivery

~~Eric A. Udren~~
~~Quanta Technology~~

~~David Harper~~
~~NRG Texas Maintenance Services~~

Scott Vaughan
City of Roseville Electric Department

James M. Kinney
FirstEnergy Corporation

Matthew Westrich
American Transmission Company

~~Mark Lucas~~
~~ComEd~~

Philip B. Winston
Southern Company Transmission

Kristina Marriott
ENOSERV

~~John A. Zipp~~
~~ITC Holdings~~

Consideration of Directives

Project 2007-17.4 – PRC-005 Order 803 Directive

April 22, 2015

Project 2007-17.4 – PRC-005 Order 803 Directive

Issue or Directive	Source	Consideration of Issue or Directive
<p>In Order No. 803, FERC approved Standard PRC-005-3 and, in Paragraph 31, directed NERC to:</p> <p>"...direct that, pursuant to section 215(d)(5) of the FPA, NERC develop modifications to PRC-005-3 to include supervisory devices associated with auto-reclosing relay schemes to which the Reliability Standard applies. Further, we clarify that NERC's proposal regarding the scope of supervisory devices is an acceptable approach to satisfy the Commission directive. Specifically, NERC proposed in its NOPR comments, and we find acceptable, that the scope of the supervisory devices to be encompassed in the Reliability Standard are those providing voltage supervision, supervisory inputs associated with selective auto-reclosing, and sync-check relays that are part of a reclosing scheme covered by PRC-005-3."</p>	<p>FERC Order 803 approving Reliability Standard PRC-005-3, P Protection System, Automatic Reclosing, and Sudden Pressure Relaying Maintenance</p>	<p>The Protection System Maintenance and Testing Standard Drafting Team (PSMTSDT) proposed revision of the standard specific defined terms "Automatic Reclosing" and "Component Type" as follows:</p> <p>Automatic Reclosing – Includes the following Components:</p> <ul style="list-style-type: none"> • Reclosing relay • Supervisory relay(s) – relay(s) that perform voltage and/or sync check functions that enables or disables operation of the reclosing relay • Voltage sensing devices associated with the supervisory relay(s) • Control circuitry associated with the reclosing relay or supervisory relay(s) <p>Component Type –</p>

Project 2007-17.4 – PRC-005 Order 803 Directive

Issue or Directive	Source	Consideration of Issue or Directive
		<ul style="list-style-type: none"> • Any one of the five specific elements of a Protection System. • Any one of the two four specific elements of Automatic Reclosing. • Any one of the two specific elements of Sudden Pressure Relaying. <p>The Rationales for “Automatic Relaying” and “Component Type” were also revised to reflect the proposed revisions to the defined terms above. Tables 4-1 and 4-2 were updated by adding “supervisory relay(s)” as appropriate. A new Table 4-3 was added to address maintenance activities and intervals for Automatic Reclosing with supervisory relays. No substantive revisions are being proposed for the Requirements of the standard. The only revisions to Requirements R1 and R3 included updating the Table numbering to reflect the addition of Table 4-3. The VSLs were updated to reflect the Requirement language for R1 and R3. All references to table numbering throughout the standard have also been corrected to reflect the addition of Table 4-3. This version of PRC-005 used PRC-005-5 developed under Project 2014-01 as the starting point for revisions to address the directive.</p>

Standards Announcement

Project 2007-17.4 PRC-005 FERC Order No. 803 Directive Standard Authorization Request

Informal Comment Period Open through July 10, 2015

[Now Available](#)

A 30-day informal comment period for the revised **Project 2007-17.4 PRC-005 FERC Order No. 803 Directive** Standard Authorization Request (SAR) is open through **8 p.m. Eastern, Friday, July 10, 2015**.

Since the approval of PRC-005-2, a number of standards development projects have resulted in revisions to PRC-005. Currently, there are eight approved or currently proposed PRC-005 Versions, and each Version comes with a separate Implementation Plan. To address this implementation concern, the PRC-005 drafting team requested that NERC align the effective dates of all outstanding PRC-005 Versions, thus simplifying the implementation schedule for this Reliability Standard. Refer to the Implementation Plan Rationale posted on the project page for further information.

Commenting

Use the [electronic form](#) to submit comments on the revised SAR. If you experience any difficulties in using the electronic form, contact [Wendy Muller](#). An unofficial Word version of the comment form is posted on the [project page](#).

For information on the Standards Development Process, refer to the [Standard Processes Manual](#).

For more information or assistance, contact Senior Standards Developer, [Stephen Crutchfield](#) (via email), or at (609) 651-9455.

North American Electric Reliability Corporation

3353 Peachtree Rd, NE

Suite 600, North Tower

Atlanta, GA 30326

404-446-2560 | www.nerc.com

Survey Report

Survey Details

Name 2007-17.4 PRC-005 FERC Order No. 803 Directive SAR

Description

Start Date 6/11/2015

End Date 7/10/2015

Associated Ballots

Survey Questions

1. Do you agree that the scope and objectives of the SAR address the directive in Order No. 803? If not, please explain why you do not agree and, if possible, provide specific language revisions that would make it acceptable to you.

Yes

No

2. The PSMTSDT has proposed revising the definition of “Automatic Reclosing” and “Component Type” to address the FERC directive in Order 803. Do you agree that the proposed revised definitions? If not, please provide specific comments regarding the revision and any suggestions for alternatives to address the directive.

Yes

No

3. The PSMTSDT has added Table 4-3 to address maintenance activities and intervals for voltage sensing devices associated with supervisory relays. Do you agree with the proposed table? If not, please provide specific comments regarding the table and any suggestions for alternative language.

Yes

No

4. The PSMTSDT has made revisions to the Supplementary Reference and FAQ Document. Do you agree with the proposed revisions? If not, please provide specific comments regarding the revisions and any suggestions for alternative language.

Yes

No

5. The PSMTSDT has proposed combining the Implementation Plans for previous versions of PRC-005 (including PRC-005-3, PRC-005-3i, PRC-005-3ii, PRC-005-4 and PRC-005-5). Do you agree with the proposed Implementation Plan? If not, please provide specific comments regarding the Implementation Plan and any suggestions for alternative language.

Yes

No

Responses By Question

1. Do you agree that the scope and objectives of the SAR address the directive in Order No. 803? If not, please explain why you do not agree and, if possible, provide specific language revisions that would make it acceptable to you.

John Fontenot - Bryan Texas Utilities - 1 -

Selected Answer: Yes

Answer Comment:

Document Name:

Likes: 0

Dislikes: 0

Thomas Foltz - AEP - 5 -

Selected Answer: Yes

Answer Comment:

Document Name:

Likes: 0

Dislikes: 0

Kaleb Brimhall - Colorado Springs Utilities - 5 -

Selected Answer:

Answer Comment:

Document Name:

Likes: 0

Dislikes: 0

Gul Khan - Oncor Electric Delivery - 2 - TRE

Selected Answer: Yes

Answer Comment:

Document Name:

Likes: 0

Dislikes: 0

Maryclaire Yatsko - Seminole Electric Cooperative, Inc. - 1,3,4,5,6 - FRCC

Selected Answer: No

Answer Comment:

Control circuitry associated with the reclosing relay or supervisory relays is unclear and needs a better definition. Closing circuitry devices that are to be excluded should be enumerated for clarity.

Document Name:

Likes: 0

Dislikes: 0

Mike Smith - Manitoba Hydro - 1 -

Selected Answer: Yes

Answer Comment:

Document Name:

Likes: 0

Dislikes: 0

Andrew Puztai - American Transmission Company, LLC - 1 -

Selected Answer: Yes

Answer Comment:

Document Name:

Likes: 0

Dislikes: 0

Randi Heise - Dominion - Dominion Resources, Inc. - 5 -

Group Information

Group Name: Dominion - RCS

Group Member Name	Entity	Region	Segments
Larry Nash	Dominion Virginia Power	SERC	1
Louis Slade	Dominion Resources, Inc.	SERC	6
Connie Lowe	Dominion Resources, Inc.	RFC	3
Randi Heise	Dominion Resources, Inc.	NPCC	5

Voter Information

Voter **Segment**
Randi Heise 5

Entity **Region(s)**
Dominion - Dominion Resources, Inc.

Selected Answer: No

Answer Comment: Dominion does **not** agree with inclusion of Balancing Authority in the Reliability Functions portion of the SAR.

Document Name:

Likes: 0

Dislikes: 0

Chris Scanlon - Exelon - 1 -

Group Information

Group Name: Exelon Utilities

Group Member Name	Entity	Region	Segments
Chris Scanlon	BGE, ComEd, PECO TO's	RFC	1
John Bee	BGE, ComEd, PECO LSE's	RFC	3

Voter Information

Voter	Segment
Chris Scanlon	1
Entity	Region(s)
Exelon	

Selected Answer: Yes

Answer Comment: We agree that the SAR addresses the directive in Order No. 803, however we have issues with the revised definition of Automatic Reclosing in the draft of PRC-005-6. See response in question #2.

Document Name:

Likes: 0

Dislikes: 0

Emily Rousseau - MRO - 1,2,3,4,5,6 - MRO

Group Information

Group Name: MRO-NERC Standards Review Forum (NSRF)

Group Member Name	Entity	Region	Segments
Joe Depoorter	Madison Gas & Electric	MRO	3,4,5,6
Amy Casucelli	Xcel Energy	MRO	1,3,5,6
Chuck Lawrence	American Transmission Company	MRO	1
Chuck Wicklund	Otter Tail Power Company	MRO	1,3,5
Theresa Allard	Minnkota Power Cooperative, Inc	MRO	1,3,5,6
Dave Rudolph	Basin Electric Power Cooperative	MRO	1,3,5,6
Kayleigh Wilkerson	Lincoln Electric System	MRO	1,3,5,6
Jodi Jenson	Western Area Power Administration	MRO	1,6
Larry Heckert	Alliant Energy	MRO	4
Mahmood Safi	Omaha Public Utility District	MRO	1,3,5,6
Marie Knox	Midwest ISO Inc.	MRO	2
Mike Brytowski	Great River Energy	MRO	1,3,5,6
Randi Nyholm	Minnesota Power	MRO	1,5
Scott Nickels	Rochester Public Utilities	MRO	4
Terry Harbour	MidAmerican Energy Company	MRO	1,3,5,6
Tom Breene	Wisconsin Public Service Corporation	MRO	3,4,5,6
Tony Eddleman	Nebraska Public Power District	MRO	1,3,5

Voter Information

Voter	Segment
Emily Rousseau	1,2,3,4,5,6
Entity	Region(s)
MRO	MRO

Selected Answer: Yes

Answer Comment:

Document Name:

Likes: 0

Dislikes: 0

Stanley Beasley - Georgia Transmission Corporation - 1 - SERC

Selected Answer: Yes

Answer Comment:

Document Name:

Likes: 0

Dislikes: 0

Molly Devine - IDACORP - Idaho Power Company - 1 -

Selected Answer: Yes

Answer Comment:

Document Name:

Likes: 0

Dislikes: 0

Venona Greaff - Oxy - Occidental Chemical - 7 -

Selected Answer: Yes

Answer Comment:

Occidental Chemical Corporation (OCC) agrees that the project team took the proper action to re-write the SAR to directly focus on Order No. 803. Although the previous version accurately reflected the intent of the initiative in our view, the attempt to include the work description in the original SAR was clearly confusing to some stakeholders. We agree that a consensus will only be reached if the document tightly reflects the language in FERC's directives – and cannot be interpreted in a manner that expands scope beyond that point.

Document Name:

Likes: 0

Dislikes: 0

Jeri Freimuth - APS - Arizona Public Service Co. - 1,3,5,6 - WECC

Selected Answer:

Answer Comment:

Document Name:

Likes: 0

Dislikes: 0

David Greene - SERC Reliability Corporation - 1 - SERC

Group Information

Group Name: SERC PCS

Group Member Name	Entity	Region	Segments
Paul Nauert	Ameren	SERC	1
Charlie Fink	Entergy	SERC	1
David Greene	SERC staff	SERC	10

Voter Information

Voter **Segment**

David Greene 1

Entity **Region(s)**

SERC Reliability Corporation SERC

Selected Answer: Yes

Answer Comment:

Document Name:

Likes: 0

Dislikes: 0

Rachel Coyne - Texas Reliability Entity, Inc. - 10 -

Selected Answer: Yes

Answer Comment:

Document Name:

Likes: 0

Dislikes: 0

David Jendras - Ameren - Ameren Services - 3 -

Selected Answer: Yes

Answer Comment:

Document Name:

Likes: 0

Dislikes: 0

Lee Pedowicz - Northeast Power Coordinating Council - 10 - NPCC**Group Information**

Group Name: NPCC--Project 2007-17.4

Group Member Name	Entity	Region	Segments
Alan Adamson	New York State Reliability Council, LLC	NPCC	10
David Burke	Orange and Rockland Utilities Inc.	NPCC	3
Greg Campoli	New York Independent System Operator	NPCC	2
Sylvain Clermont	Hydro-Quebec TransEnergie	NPCC	1
Kelly Dash	Consolidated Edison Co. of New York, Inc.	NPCC	1
Gerry Dunbar	Northeast Power Coordinating Council	NPCC	10
Mark Kenny	Northeast Utilities	NPCC	1
Helen Lainis	Independent Electricity System Operator	NPCC	2
Alan MacNaughton	New Brunswick Power Corporation	NPCC	9
Paul Malozewski	Hydro One Networks Inc.	NPCC	1
Bruce Metruck	New York Power Authority	NPCC	6
Lee Pedowicz	Northeast Power Coordinating Council	NPCC	10
Robert Pellegrini	The United Illuminating Company	NPCC	1
Si Truc Phan	Hydro-Quebec TransEnergie	NPCC	1
David Ramkalawan	Ontario Power Generation, Inc.	NPCC	5
Brian Robinson	Utility Services	NPCC	8
Wayne Sipperly	New York Power Authority	NPCC	5
Edward Bedder	Orange and Rockland Utilities Inc.	NPCC	1
Peter Yost	Consolidated Edison Co. of New York, Inc.	NPCC	3
Michael Jones	National Grid	NPCC	1

Brian Shanahan	National Grid	NPCC	1
Michael Forte	Consolidated Edison Co. of New York, Inc.	NPCC	1
Glen Smith	Entergy Services, Inc.	NPCC	5
Brian O'Boyle	Consolidated Edison Co. of New York, Inc.	NPCC	8
RuiDa Shu	Northeast Power Coordinating Council	NPCC	10
Connie Lowe	Dominion Resources Services, Inc.	NPCC	5
Guy Zito	Northeast Power Coordinating Council	NPCC	10
Silvia Parada Mitchell	NextEra Energy, LLC	NPCC	5

Voter Information

Voter	Segment
Lee Pedowicz	10
Entity	Region(s)
Northeast Power Coordinating Council	NPCC

Selected Answer: No

Answer Comment: The Balancing Authority should not be included in the Reliability Functions section of the SAR. PRC-005 does not apply to a Balancing Authority.

Document Name:

Likes: 0

Dislikes: 0

Oliver Burke - Entergy - Entergy Services, Inc. - 1 -

Selected Answer: Yes

Answer Comment:

Document Name:

Likes: 0

Dislikes: 0

Dennis Chastain - Tennessee Valley Authority - 1,3,5,6 - SERC

Selected Answer: Yes

Answer Comment:

The revised SAR is much clearer than the previously posted version. In the "Detailed Description" section, bullet item #1, we believe that "PRC-002i" was intended to read "PRC-005-2i". If so, we see no need to consider PRC-005-2(i) in the implementation plan work of this SDT since FERC's approval of PRC-005-2(i) on 5/29/2015 has effectively already aligned the implementation plan of PRC-005-2(i) with that of the now retired PRC-005-2.

In the "Reliability Functions" section, we believe the Balancing Authority (BA) function was checked in error. If not, the reasoning behind expanding the applicability of PRC-005 to the BA should be explained in the SAR.

Document Name:

Likes: 0

Dislikes: 0

Oshani Pathirane - Hydro One Networks, Inc. - 1,3 - NPCC

Selected Answer: Yes

Answer Comment:

Hydro One recognizes the fact that the wording in the Objectives, and in particular, the addition of 'definitions' has been added to align with the recommendation made on the previously proposed SAR.

Document Name:

Likes: 1 Hydro One Networks, Inc., 1, Farahbakhsh Payam

Dislikes: 0

Payam Farahbakhsh - Hydro One Networks, Inc. - 1 -

Selected Answer: Yes

Answer Comment:

Document Name:

Likes: 0

Dislikes: 0

Jason Smith - Southwest Power Pool, Inc. (RTO) - 2 - MRO,SPP

Group Information

Group Name: SPP Standards Review Group

Group Member Name	Entity	Region	Segments
Shannon Mickens	Southwest Power Pool	SPP	2
James Nail	City of Independence, Missouri	SPP	3,5
Jamison Cawley	Nebraska Public Power District	MRO	1,3,5
Robert Hirschak	Cleco Power	SPP	1,3,5,6
Mike Kidwell	Empire District Electric	SPP	1,3,5
Jason Smith	Southwest Power Pool	SPP	2
Ashley Stringer	Oklahoma Municipal Power Authority	SPP	4
J. Scott Williams	City Utilities of Springfield	SPP	1,4
Ellen Watkins	Sunflower Electric Power Corporation	SPP	1

Voter Information

Voter	Segment
Jason Smith	2
Entity	Region(s)
Southwest Power Pool, Inc. (RTO)	MRO,SPP

Selected Answer: Yes

Answer Comment:

Document Name:

Likes: 0

Dislikes: 0

Leonard Kula - Independent Electricity System Operator - 2 -

Selected Answer: Yes

Answer Comment:

Document Name:

Likes: 0

Dislikes: 0

Colby Bellville - Duke Energy - 1,3,5,6 - FRCC,SERC,RFC

Group Information

Group Name: Duke Energy

Group Member Name	Entity	Region	Segments
Doug Hils	Duke Energy	RFC	1
Lee Schuster	Duke Energy	FRCC	3
Dale Goodwine	Duke Energy	SERC	5
Greg Cecil	Duke Energy	RFC	6

Voter Information

Voter	Segment
Colby Bellville	1,3,5,6
Entity	Region(s)
Duke Energy	FRCC,SERC,RFC

Selected Answer: Yes

Answer Comment:

Document Name:

Likes: 0

Dislikes: 0

Scott Langston - Tallahassee Electric (City of Tallahassee, FL) - 1 -

Selected Answer: Yes

Answer Comment:

Document Name:

Likes: 0

Dislikes: 0

Karen Webb - Tallahassee Electric (City of Tallahassee, FL) - 5 -

Selected Answer: Yes

Answer Comment:

Document Name:

Likes: 0

Dislikes: 0

John Williams - Tallahassee Electric (City of Tallahassee, FL) - 3 -

Selected Answer: Yes

Answer Comment:

Document Name:

Likes: 0

Dislikes: 0

John Merrell - Tacoma Public Utilities (Tacoma, WA) - 1 -

Selected Answer: Yes

Answer Comment:

On page 2 of the proposed SAR, strike the following sentence: "The SDT shall also consider changes to the standard and supporting documents that provide consistency and alignment with other Reliability Standards."

On page 3 of the proposed SAR, change "[m]odify the informative Supplementary Reference Document (provided as a technical reference for PRC-005-3) as necessary to provide application guidance to industry" to "[m]odify the informative Supplementary Reference Document (provided as a technical reference for PRC-005-3) as necessary to provide application guidance to industry pertaining to changes supporting FERC Order 803."

Document Name:

Likes: 0

Dislikes: 0

Andrea Jessup - Bonneville Power Administration - 1,3,5,6 - WECC

Selected Answer: Yes

Answer Comment:

Document Name:

Likes: 0

Dislikes: 0

2. The PSMTSDT has proposed revising the definition of “Automatic Reclosing” and “Component Type” to address the FERC directive in Order 803. Do you agree that the proposed revised definitions? If not, please provide specific comments regarding the revision and any suggestions for alternatives to address the directive.

John Fontenot - Bryan Texas Utilities - 1 -

Selected Answer: Yes

Answer Comment:

Document Name:

Likes: 0

Dislikes: 0

Thomas Foltz - AEP - 5 -

Selected Answer:

Answer Comment:

Document Name:

Likes: 0

Dislikes: 0

Kaleb Brimhall - Colorado Springs Utilities - 5 -

Selected Answer:

Answer Comment:

Document Name:

Likes: 0

Dislikes: 0

Gul Khan - Oncor Electric Delivery - 2 - TRE

Selected Answer: Yes

Answer Comment:

Document Name:

Likes: 0

Dislikes: 0

Maryclaire Yatsko - Seminole Electric Cooperative, Inc. - 1,3,4,5,6 - FRCC

Selected Answer: No

Answer Comment: See comments for Question 1 above.

Document Name:

Likes: 0

Dislikes: 0

Mike Smith - Manitoba Hydro - 1 -

Selected Answer: Yes

Answer Comment:

Document Name:

Likes: 0

Dislikes: 0

Andrew Puztai - American Transmission Company, LLC - 1 -

Selected Answer: Yes

Answer Comment:

Document Name:

Likes: 0

Dislikes: 0

Chris Scanlon - Exelon - 1 -

Group Information

Group Name: Exelon Utilities

Group Member Name	Entity	Region	Segments
Chris Scanlon	BGE, ComEd, PECO TO's	RFC	1
John Bee	BGE, ComEd, PECO LSE's	RFC	3

Voter Information

Voter	Segment
Chris Scanlon	1
Entity	Region(s)
Exelon	

Selected Answer: No

Answer Comment:

At ComEd, the overwhelming majority of the reclosing relays for BES Elements are microprocessor based and have the supervisory functionality built into the reclosing relay. Additionally, the majority of our solid state relays for BES elements have the supervisory functionality built into the reclosing relay. Although the standard meets the intention of FERC Order 803, the term "supervisory relay" refers to an antiquated methodology. It seems that "supervisory functionality" would be more appropriate. ComEd would prefer that the NERC standard changed the definition of Automatic Reclosing in the standard to state: "Automatic Reclosing Equipment - Equipment which automatically restores a BES Element(s) after a Protection System Operation. This equipment includes the device which issues the actual reclose pulse, any supervisory functionality (e.g, voltage check, sync check, or timing), any voltage sensing devices associated with the supervisory functionality, and any control circuitry necessary for the automatic reclosing to perform as designed. Note that the purpose of including Automatic Reclosing Equipment in the PRC-005 standard is to ensure that a premature close is not issued to a circuit breaker, not to ensure that a non-RAS circuit breaker actually recloses."

Document Name:

Likes: 0

Dislikes:

0

Emily Rousseau - MRO - 1,2,3,4,5,6 - MRO

Group Information

Group Name: MRO-NERC Standards Review Forum (NSRF)

Group Member Name	Entity	Region	Segments
Joe Depoorter	Madison Gas & Electric	MRO	3,4,5,6
Amy Casucelli	Xcel Energy	MRO	1,3,5,6
Chuck Lawrence	American Transmission Company	MRO	1
Chuck Wicklund	Otter Tail Power Company	MRO	1,3,5
Theresa Allard	Minnkota Power Cooperative, Inc	MRO	1,3,5,6
Dave Rudolph	Basin Electric Power Cooperative	MRO	1,3,5,6
Kayleigh Wilkerson	Lincoln Electric System	MRO	1,3,5,6
Jodi Jenson	Western Area Power Administration	MRO	1,6
Larry Heckert	Alliant Energy	MRO	4
Mahmood Safi	Omaha Public Utility District	MRO	1,3,5,6
Marie Knox	Midwest ISO Inc.	MRO	2
Mike Brytowski	Great River Energy	MRO	1,3,5,6
Randi Nyholm	Minnesota Power	MRO	1,5
Scott Nickels	Rochester Public Utilities	MRO	4
Terry Harbour	MidAmerican Energy Company	MRO	1,3,5,6
Tom Breene	Wisconsin Public Service Corporation	MRO	3,4,5,6
Tony Eddleman	Nebraska Public Power District	MRO	1,3,5

Voter Information

Voter	Segment
Emily Rousseau	1,2,3,4,5,6
Entity	Region(s)
MRO	MRO

Selected Answer: Yes

Answer Comment:

Document Name:

Likes: 0

Dislikes: 0

Stanley Beasley - Georgia Transmission Corporation - 1 - SERC

Selected Answer: Yes

Answer Comment:

Document Name:

Likes: 0

Dislikes: 0

Molly Devine - IDACORP - Idaho Power Company - 1 -

Selected Answer: Yes

Answer Comment:

Document Name:

Likes: 0

Dislikes: 0

Venona Greaff - Oxy - Occidental Chemical - 7 -

Selected Answer: Yes

Answer Comment:

OCC commends the project team for updating the definition of "Automatic Reclosing" to directly align with the Commission's order. The previous version was open-ended in our view, and could apply to other supervisory functions beyond voltage and synch control that have no effect on BES reliability.

Document Name:

Likes: 0

Dislikes: 0

Jeri Freimuth - APS - Arizona Public Service Co. - 1,3,5,6 - WECC

Selected Answer:

Answer Comment:

Document Name:

Likes: 0

Dislikes: 0

David Greene - SERC Reliability Corporation - 1 - SERC

Group Information

Group Name: SERC PCS

Group Member Name	Entity	Region	Segments
Paul Nauert	Ameren	SERC	1
Charlie Fink	Entergy	SERC	1
David Greene	SERC staff	SERC	10

Voter Information

Voter	Segment
David Greene	1
Entity	Region(s)
SERC Reliability Corporation	SERC

Selected Answer: Yes

Answer Comment:

Document Name:

Likes: 0

Dislikes: 0

Rachel Coyne - Texas Reliability Entity, Inc. - 10 -

Selected Answer: Yes

Answer Comment:

Document Name:

Likes: 0

Dislikes: 0

David Jendras - Ameren - Ameren Services - 3 -

Selected Answer: Yes

Answer Comment:

Document Name:

Likes: 0

Dislikes: 0

Lee Pedowicz - Northeast Power Coordinating Council - 10 - NPCC

Group Information

Group Name: NPCC--Project 2007-17.4

Group Member Name	Entity	Region	Segments
Alan Adamson	New York State Reliability Council, LLC	NPCC	10
David Burke	Orange and Rockland Utilities Inc.	NPCC	3
Greg Campoli	New York Independent System Operator	NPCC	2
Sylvain Clermont	Hydro-Quebec TransEnergie	NPCC	1
Kelly Dash	Consolidated Edison Co. of New York, Inc.	NPCC	1
Gerry Dunbar	Northeast Power Coordinating Council	NPCC	10
Mark Kenny	Northeast Utilities	NPCC	1
Helen Lainis	Independent Electricity System Operator	NPCC	2
Alan MacNaughton	New Brunswick Power Corporation	NPCC	9
Paul Malozewski	Hydro One Networks Inc.	NPCC	1
Bruce Metruck	New York Power Authority	NPCC	6
Lee Pedowicz	Northeast Power Coordinating Council	NPCC	10
Robert Pellegrini	The United Illuminating Company	NPCC	1
Si Truc Phan	Hydro-Quebec TransEnergie	NPCC	1
David Ramkalawan	Ontario Power Generation, Inc.	NPCC	5
Brian Robinson	Utility Services	NPCC	8
Wayne Sipperly	New York Power Authority	NPCC	5
Edward Bedder	Orange and Rockland Utilities Inc.	NPCC	1
Peter Yost	Consolidated Edison Co. of New York, Inc.	NPCC	3
Michael Jones	National Grid	NPCC	1

Brian Shanahan	National Grid	NPCC	1
Michael Forte	Consolidated Edison Co. of New York, Inc.	NPCC	1
Glen Smith	Entergy Services, Inc.	NPCC	5
Brian O'Boyle	Consolidated Edison Co. of New York, Inc.	NPCC	8
RuiDa Shu	Northeast Power Coordinating Council	NPCC	10
Connie Lowe	Dominion Resources Services, Inc.	NPCC	5
Guy Zito	Northeast Power Coordinating Council	NPCC	10
Silvia Parada Mitchell	NextEra Energy, LLC	NPCC	5

Voter Information

Voter	Segment
Lee Pedowicz	10
Entity	Region(s)
Northeast Power Coordinating Council	NPCC

Selected Answer: No

Answer Comment:

The definition of Automatic Reclosing should have words to describe what Automatic Reclosing is in addition to the components that comprise it. Suggest wording similar to: Automatic Reclosing is a control scheme or system for automatically closing circuit breakers that have automatically tripped in response to abnormal system conditions. The PSMTSDT should consider changing the nomenclature of what is to be defined to "Automatic Reclosing System".

The listing of new definitions in Section 6 of the Introduction of the Standard is inconsistent with other NERC standards which have them listed on the Definitions of Terms Used in Standard page.

Document Name:

Likes: 0

Dislikes: 0

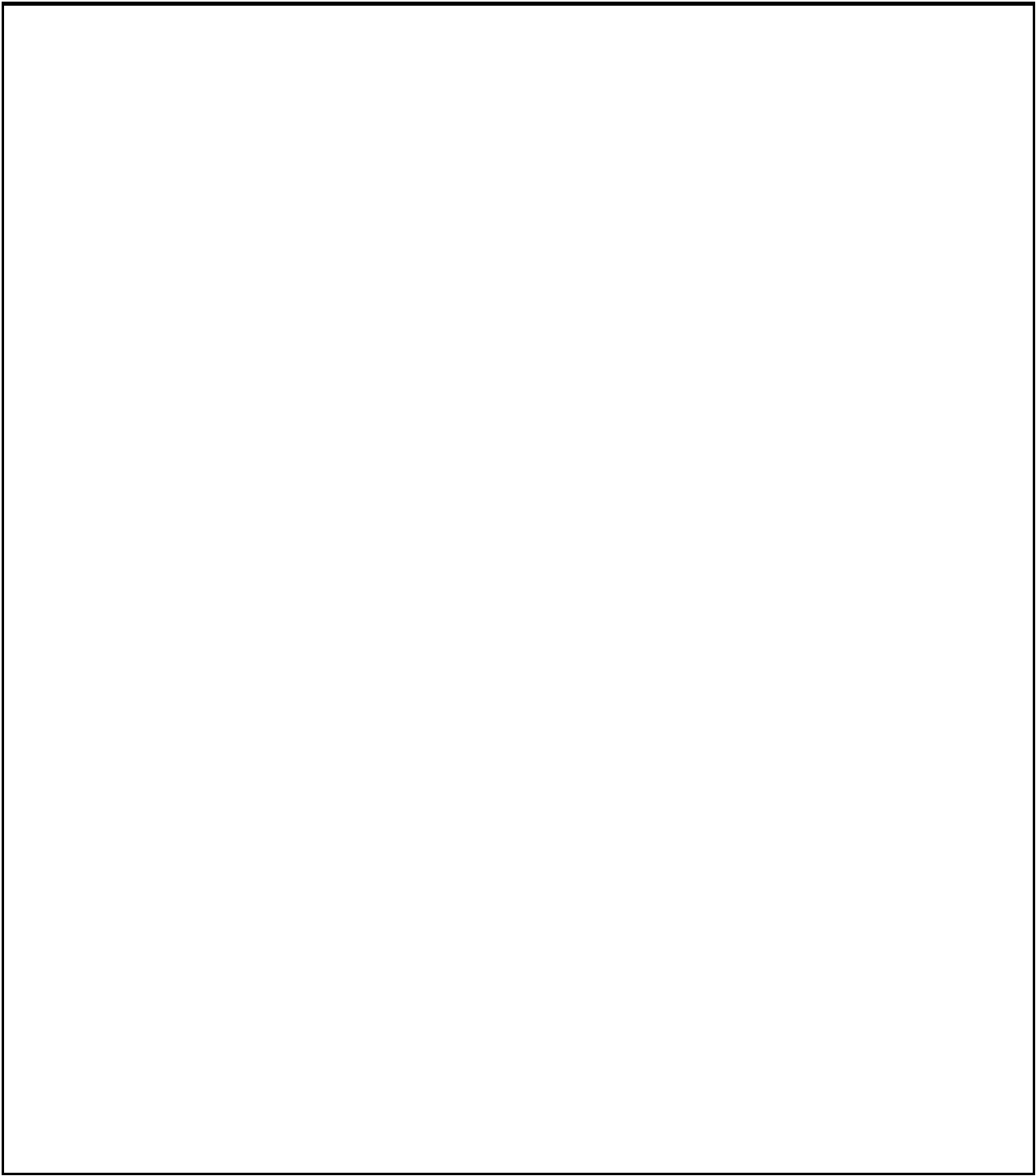

Oliver Burke - Entergy - Entergy Services, Inc. - 1 -

Selected Answer: Yes

Answer Comment:

Document Name:

Likes: 0

Dislikes: 0

Dennis Chastain - Tennessee Valley Authority - 1,3,5,6 - SERC

Selected Answer: No

Answer Comment:

We do not agree with the addition of “Voltage sensing devices associated with the supervisory relay(s)” to the Automatic Reclosing definition, and believe these devices are beyond the scope of the FERC directive. We recommend removing the third bullet of the Automatic Reclosing definition, and modifying the second bullet of the Component Type to read “Any one of the three specific elements of Automatic Reclosing.”

Document Name:

Likes: 0

Dislikes: 0

Oshani Pathirane - Hydro One Networks, Inc. - 1,3 - NPCC

Selected Answer: No

Answer Comment:

Although Hydro One is generally satisfied with the existing definition of “Automatic Reclosing” as it includes the 4 major components constituting its functionality, the definition could further add to it the general intention of Automatic Reclosing.

Hydro One is also satisfied that the definition of “Component Type” has been extended to include all four components of an auto-reclose scheme (reclose relay, supervisory relay – voltage and synchro check, voltage sensing devices, and control circuits).

Document Name:

Likes: 0

Dislikes: 0

Payam Farahbakhsh - Hydro One Networks, Inc. - 1 -

Selected Answer: No

Answer Comment:

Document Name:

Likes: 0

Dislikes: 0

Jason Smith - Southwest Power Pool, Inc. (RTO) - 2 - MRO,SPP

Group Information

Group Name: SPP Standards Review Group

Group Member Name	Entity	Region	Segments
Shannon Mickens	Southwest Power Pool	SPP	2
James Nail	City of Independence, Missouri	SPP	3,5
Jamison Cawley	Nebraska Public Power District	MRO	1,3,5
Robert Hirschak	Cleco Power	SPP	1,3,5,6
Mike Kidwell	Empire District Electric	SPP	1,3,5
Jason Smith	Southwest Power Pool	SPP	2
Ashley Stringer	Oklahoma Municipal Power Authority	SPP	4
J. Scott Williams	City Utilities of Springfield	SPP	1,4
Ellen Watkins	Sunflower Electric Power Corporation	SPP	1

Voter Information

Voter Jason Smith **Segment** 2

Entity Southwest Power Pool, Inc. (RTO) **Region(s)** MRO,SPP

Selected Answer: Yes

Answer Comment:

Document Name:

Likes: 0

Dislikes: 0

Leonard Kula - Independent Electricity System Operator - 2 -

Selected Answer:

Answer Comment:

Document Name:

Likes: 0

Dislikes: 0

Colby Bellville - Duke Energy - 1,3,5,6 - FRCC,SERC,RFC

Group Information

Group Name: Duke Energy

Group Member Name	Entity	Region	Segments
Doug Hils	Duke Energy	RFC	1
Lee Schuster	Duke Energy	FRCC	3
Dale Goodwine	Duke Energy	SERC	5
Greg Cecil	Duke Energy	RFC	6

Voter Information

Voter	Segment
Colby Bellville	1,3,5,6
Entity	Region(s)
Duke Energy	FRCC,SERC,RFC

Selected Answer: No

Answer Comment:

Duke Energy suggests that additional language be provided to the definition or perhaps the Supplementary Reference/FAQ document which further clarifies that supervisory devices do not include SCADA/SCADA control. Specifically, the last bullet in the proposed definition of Automatic Reclosing could be misunderstood to mean SCADA supervisory control. It may be helpful to provide more detail into what constitutes said "supervisory relay" similar to the scope that NERC proposed in its NOPR comments to FERC, and which FERC approved, that stated that:

"supervisory devices to be encompassed in the Reliability Standard are those providing voltage supervision, supervisory inputs associated with selective auto-reclosing, and sync-check relays that are part of a reclosing scheme covered by PRC-005-3."

We feel that adding more detailed language, as provided above, may decrease the possibility of misinterpretation or the wrongful inclusion of areas such as SCADA control into the scope of this standard.

Document Name:

Likes: 0

Dislikes: 0

Scott Langston - Tallahassee Electric (City of Tallahassee, FL) - 1 -

Selected Answer: Yes

Answer Comment:

Document Name:

Likes: 0

Dislikes: 0

Karen Webb - Tallahassee Electric (City of Tallahassee, FL) - 5 -

Selected Answer: Yes

Answer Comment:

Document Name:

Likes: 0

Dislikes: 0

John Williams - Tallahassee Electric (City of Tallahassee, FL) - 3 -

Selected Answer: Yes

Answer Comment:

Document Name:

Likes: 0

Dislikes: 0

John Merrell - Tacoma Public Utilities (Tacoma, WA) - 1 -

Selected Answer: Yes

Answer Comment:

Document Name:

Likes: 0

Dislikes: 0

Andrea Jessup - Bonneville Power Administration - 1,3,5,6 - WECC

Selected Answer: Yes

Answer Comment:

Document Name:

Likes: 0

Dislikes: 0

3. The PSMTSDT has added Table 4-3 to address maintenance activities and intervals for voltage sensing devices associated with supervisory relays. Do you agree with the proposed table? If not, please provide specific comments regarding the table and any suggestions for alternative language.

John Fontenot - Bryan Texas Utilities - 1 -

Selected Answer: Yes

Answer Comment:

Document Name:

Likes: 0

Dislikes: 0

Thomas Foltz - AEP - 5 -

Selected Answer:

Answer Comment:

Document Name:

Likes: 0

Dislikes: 0

Kaleb Brimhall - Colorado Springs Utilities - 5 -

Selected Answer:

Answer Comment:

Document Name:

Likes: 0

Dislikes: 0

Gul Khan - Oncor Electric Delivery - 2 - TRE

Selected Answer: Yes

Answer Comment:

Document Name:

Likes: 0

Dislikes: 0

Maryclaire Yatsko - Seminole Electric Cooperative, Inc. - 1,3,4,5,6 - FRCC

Selected Answer: No

Answer Comment: Closing circuitry devices that are to be excluded should be specifically stated in the Standard.

Document Name:

Likes: 0

Dislikes: 0

Mike Smith - Manitoba Hydro - 1 -

Selected Answer: Yes

Answer Comment:

Document Name:

Likes: 0

Dislikes: 0

Andrew Puztai - American Transmission Company, LLC - 1 -

Selected Answer: Yes

Answer Comment:

Document Name:

Likes: 0

Dislikes: 0

Chris Scanlon - Exelon - 1 -

Group Information

Group Name: Exelon Utilities

Group Member Name	Entity	Region	Segments
Chris Scanlon	BGE, ComEd, PECO TO's	RFC	1
John Bee	BGE, ComEd, PECO LSE's	RFC	3

Voter Information

Voter	Segment
Chris Scanlon	1
Entity	Region(s)
Exelon	

Selected Answer: No

Answer Comment: We agree with the intervals and the intent. We do not agree with the names in the Component Attributes because of our disagreement with the Automatic Reclosing Definition. See our response in #2.

Document Name:

Likes: 0

Dislikes: 0

Emily Rousseau - MRO - 1,2,3,4,5,6 - MRO

Group Information

Group Name: MRO-NERC Standards Review Forum (NSRF)

Group Member Name	Entity	Region	Segments
Joe Depoorter	Madison Gas & Electric	MRO	3,4,5,6
Amy Casucelli	Xcel Energy	MRO	1,3,5,6
Chuck Lawrence	American Transmission Company	MRO	1
Chuck Wicklund	Otter Tail Power Company	MRO	1,3,5
Theresa Allard	Minnkota Power Cooperative, Inc	MRO	1,3,5,6
Dave Rudolph	Basin Electric Power Cooperative	MRO	1,3,5,6
Kayleigh Wilkerson	Lincoln Electric System	MRO	1,3,5,6
Jodi Jenson	Western Area Power Administration	MRO	1,6
Larry Heckert	Alliant Energy	MRO	4
Mahmood Safi	Omaha Public Utility District	MRO	1,3,5,6
Marie Knox	Midwest ISO Inc.	MRO	2
Mike Brytowski	Great River Energy	MRO	1,3,5,6
Randi Nyholm	Minnesota Power	MRO	1,5
Scott Nickels	Rochester Public Utilities	MRO	4
Terry Harbour	MidAmerican Energy Company	MRO	1,3,5,6
Tom Breene	Wisconsin Public Service Corporation	MRO	3,4,5,6
Tony Eddleman	Nebraska Public Power District	MRO	1,3,5

Voter Information

Voter	Segment
Emily Rousseau	1,2,3,4,5,6
Entity	Region(s)
MRO	MRO

Selected Answer: Yes

Answer Comment:

Document Name:

Likes: 0

Dislikes: 0

Stanley Beasley - Georgia Transmission Corporation - 1 - SERC

Selected Answer: Yes

Answer Comment:

Document Name:

Likes: 0

Dislikes: 0

Molly Devine - IDACORP - Idaho Power Company - 1 -

Selected Answer: Yes

Answer Comment:

Document Name:

Likes: 0

Dislikes: 0

Venona Greaff - Oxy - Occidental Chemical - 7 -

Selected Answer: Yes

Answer Comment:

OCC agrees that the maintenance activities and intervals are consistent with all the other Protection System components subject to PRC-005-6.

Document Name:

Likes: 0

Dislikes: 0

Jeri Freimuth - APS - Arizona Public Service Co. - 1,3,5,6 - WECC

Selected Answer:

Answer Comment:

Document Name:

Likes: 0

Dislikes: 0

David Greene - SERC Reliability Corporation - 1 - SERC

Group Information

Group Name: SERC PCS

Group Member Name	Entity	Region	Segments
Paul Nauert	Ameren	SERC	1
Charlie Fink	Entergy	SERC	1
David Greene	SERC staff	SERC	10

Voter Information

Voter David Greene **Segment** 1

Entity SERC Reliability Corporation **Region(s)** SERC

Selected Answer: Yes

Answer Comment:

Document Name:

Likes: 0

Dislikes: 0

Rachel Coyne - Texas Reliability Entity, Inc. - 10 -

Selected Answer: Yes

Answer Comment:

There are no questions provided regarding Table 4-1 and the following appeared to fit here best. Please clarify the following: In Table 4-1, is it correct to assume "preceding row" as referenced on page 35 is referencing all the Component Attributes for the 12 Calendar Years "row" ? Or just certain aspects of the "preceding row" (e.g. supervisory relay attributes ONLY)?

Document Name:

Likes: 0

Dislikes: 0

David Jendras - Ameren - Ameren Services - 3 -

Selected Answer: Yes

Answer Comment:

Document Name:

Likes: 0

Dislikes: 0

Lee Pedowicz - Northeast Power Coordinating Council - 10 - NPCC

Group Information

Group Name: NPCC--Project 2007-17.4

Group Member Name	Entity	Region	Segments
Alan Adamson	New York State Reliability Council, LLC	NPCC	10
David Burke	Orange and Rockland Utilities Inc.	NPCC	3
Greg Campoli	New York Independent System Operator	NPCC	2
Sylvain Clermont	Hydro-Quebec TransEnergie	NPCC	1
Kelly Dash	Consolidated Edison Co. of New York, Inc.	NPCC	1
Gerry Dunbar	Northeast Power Coordinating Council	NPCC	10
Mark Kenny	Northeast Utilities	NPCC	1
Helen Lainis	Independent Electricity System Operator	NPCC	2
Alan MacNaughton	New Brunswick Power Corporation	NPCC	9
Paul Malozewski	Hydro One Networks Inc.	NPCC	1
Bruce Metruck	New York Power Authority	NPCC	6
Lee Pedowicz	Northeast Power Coordinating Council	NPCC	10
Robert Pellegrini	The United Illuminating Company	NPCC	1
Si Truc Phan	Hydro-Quebec TransEnergie	NPCC	1
David Ramkalawan	Ontario Power Generation, Inc.	NPCC	5
Brian Robinson	Utility Services	NPCC	8
Wayne Sipperly	New York Power Authority	NPCC	5
Edward Bedder	Orange and Rockland Utilities Inc.	NPCC	1
Peter Yost	Consolidated Edison Co. of New York, Inc.	NPCC	3
Michael Jones	National Grid	NPCC	1

Brian Shanahan	National Grid	NPCC	1
Michael Forte	Consolidated Edison Co. of New York, Inc.	NPCC	1
Glen Smith	Entergy Services, Inc.	NPCC	5
Brian O'Boyle	Consolidated Edison Co. of New York, Inc.	NPCC	8
RuiDa Shu	Northeast Power Coordinating Council	NPCC	10
Connie Lowe	Dominion Resources Services, Inc.	NPCC	5
Guy Zito	Northeast Power Coordinating Council	NPCC	10
Silvia Parada Mitchell	NextEra Energy, LLC	NPCC	5

Voter Information

Voter	Segment
Lee Pedowicz	10
Entity	Region(s)
Northeast Power Coordinating Council	NPCC

Selected Answer: Yes

Answer Comment:

Document Name:

Likes: 0

Dislikes: 0

Oliver Burke - Entergy - Entergy Services, Inc. - 1 -

Selected Answer: Yes

Answer Comment:

Document Name:

Likes: 0

Dislikes: 0

Dennis Chastain - Tennessee Valley Authority - 1,3,5,6 - SERC

Selected Answer: No

Answer Comment:

As stated above, we do not agree with the addition of “Voltage sensing devices associated with the supervisory relay(s)” to the revised Automatic Reclosing definition. Therefore we believe Table 4-3 is unnecessary. In the event that “Voltage sensing devices associated with the supervisory relay(s)” remains a part of the revised definition, we believe the maintenance interval for that component type is already addressed in Table 1-3. Minor wording changes to Table 1-3 would be preferable to having two tables that address the same component type.

Document Name:

Likes: 0

Dislikes: 0

Oshani Pathirane - Hydro One Networks, Inc. - 1,3 - NPCC

Selected Answer:

Answer Comment:

Document Name:

Likes: 0

Dislikes: 0

Payam Farahbakhsh - Hydro One Networks, Inc. - 1 -

Selected Answer:

Answer Comment:

Document Name:

Likes: 0

Dislikes: 0

Jason Smith - Southwest Power Pool, Inc. (RTO) - 2 - MRO,SPP

Group Information

Group Name: SPP Standards Review Group

Group Member Name	Entity	Region	Segments
Shannon Mickens	Southwest Power Pool	SPP	2
James Nail	City of Independence, Missouri	SPP	3,5
Jamison Cawley	Nebraska Public Power District	MRO	1,3,5
Robert Hirschak	Cleco Power	SPP	1,3,5,6
Mike Kidwell	Empire District Electric	SPP	1,3,5
Jason Smith	Southwest Power Pool	SPP	2
Ashley Stringer	Oklahoma Municipal Power Authority	SPP	4
J. Scott Williams	City Utilities of Springfield	SPP	1,4
Ellen Watkins	Sunflower Electric Power Corporation	SPP	1

Voter Information

Voter Jason Smith **Segment** 2

Entity Southwest Power Pool, Inc. (RTO) **Region(s)** MRO,SPP

Selected Answer: Yes

Answer Comment:

Document Name:

Likes: 0

Dislikes: 0

Leonard Kula - Independent Electricity System Operator - 2 -

Selected Answer: Yes

Answer Comment:

Document Name:

Likes: 0

Dislikes: 0

Colby Bellville - Duke Energy - 1,3,5,6 - FRCC,SERC,RFC

Group Information

Group Name: Duke Energy

Group Member Name	Entity	Region	Segments
Doug Hils	Duke Energy	RFC	1
Lee Schuster	Duke Energy	FRCC	3
Dale Goodwine	Duke Energy	SERC	5
Greg Cecil	Duke Energy	RFC	6

Voter Information

Voter	Segment
Colby Bellville	1,3,5,6
Entity	Region(s)
Duke Energy	FRCC,SERC,RFC

Selected Answer: Yes

Answer Comment:

Document Name:

Likes: 0

Dislikes: 0

Scott Langston - Tallahassee Electric (City of Tallahassee, FL) - 1 -

Selected Answer: Yes

Answer Comment:

Document Name:

Likes: 0

Dislikes: 0

Karen Webb - Tallahassee Electric (City of Tallahassee, FL) - 5 -

Selected Answer: Yes

Answer Comment:

Document Name:

Likes: 0

Dislikes: 0

John Williams - Tallahassee Electric (City of Tallahassee, FL) - 3 -

Selected Answer: Yes

Answer Comment:

Document Name:

Likes: 0

Dislikes: 0

John Merrell - Tacoma Public Utilities (Tacoma, WA) - 1 -

Selected Answer: Yes

Answer Comment:

Document Name:

Likes: 0

Dislikes: 0

Andrea Jessup - Bonneville Power Administration - 1,3,5,6 - WECC

Selected Answer: Yes

Answer Comment:

Document Name:

Likes: 0

Dislikes: 0

4. The PSMTSDT has made revisions to the Supplementary Reference and FAQ Document. Do you agree with the proposed revisions? If not, please provide specific comments regarding the revisions and any suggestions for alternative language.

John Fontenot - Bryan Texas Utilities - 1 -

Selected Answer: Yes

Answer Comment:

Document Name:

Likes: 0

Dislikes: 0

Thomas Foltz - AEP - 5 -

Selected Answer:

Answer Comment:

Document Name:

Likes: 0

Dislikes: 0

Kaleb Brimhall - Colorado Springs Utilities - 5 -

Selected Answer:

Answer Comment:

Document Name:

Likes: 0

Dislikes: 0

Gul Khan - Oncor Electric Delivery - 2 - TRE

Selected Answer: Yes

Answer Comment:

Document Name:

Likes: 0

Dislikes: 0

Maryclaire Yatsko - Seminole Electric Cooperative, Inc. - 1,3,4,5,6 - FRCC

Selected Answer: No

Answer Comment:

We have been told numerous times that the Supplementary Reference and FAQ are not part of the Standard; however, for clarity the newly added closing circuitry devices (components) that require periodic maintenance should be strictly defined, and those closing devices excluded from maintenance should be clearly stated in the Standard. As a suggestion, a typical closing circuit diagram could be shown in the Supplementary Reference illustrating the closing circuitry device inclusions and exclusions. As to the use of inclusions and exclusions, these were used to better define the BES definition as completely defined by the BES SDT, as an example.

Document Name:

Likes: 1 Tallahassee Electric (City of Tallahassee, FL), 5, Webb Karen

Dislikes: 0

Mike Smith - Manitoba Hydro - 1 -

Selected Answer: Yes

Answer Comment:

Document Name:

Likes: 0

Dislikes: 0

Andrew Puztai - American Transmission Company, LLC - 1 -

Selected Answer: Yes

Answer Comment:

However, ATC has the following clarifications:

The first Frequently-asked Question in Section 15.8.1 (page 101) contains a typographical error. The last sentence should read, "Automatic Reclosing is included in the PSMP because it is a more pragmatic approach as compared to creating a parallel and essentially identical 'Control System Maintenance Program for the four Automatic Reclosing component types."

Also, ATC recommends revising the response to the question, "Do we have to test the various breaker closing circuit interlocks and controls such as anti-pumps?" (p. 102) to strike the second sentence that states, "They are indirectly verified by performing the Automatic Reclosing control circuitry verification as established in Table 4." This statement is inaccurate.

Document Name:

Likes: 0

Dislikes: 0

Randi Heise - Dominion - Dominion Resources, Inc. - 5 -

Group Information

Group Name: Dominion - RCS

Group Member Name	Entity	Region	Segments
Larry Nash	Dominion Virginia Power	SERC	1
Louis Slade	Dominion Resources, Inc.	SERC	6
Connie Lowe	Dominion Resources, Inc.	RFC	3
Randi Heise	Dominion Resources, Inc,	NPCC	5

Voter Information

Voter	Segment
Randi Heise	5
Entity	Region(s)
Dominion - Dominion Resources, Inc.	

Selected Answer: Yes

Answer Comment:

Document Name:

Likes: 0

Dislikes: 0

Chris Scanlon - Exelon - 1 -

Group Information

Group Name: Exelon Utilities

Group Member Name	Entity	Region	Segments
Chris Scanlon	BGE, ComEd, PECO TO's	RFC	1
John Bee	BGE, ComEd, PECO LSE's	RFC	3

Voter Information

Voter **Segment**

Chris Scanlon 1

Entity **Region(s)**

Exelon

Selected Answer: Yes

Answer Comment: As mentioned above in #2, we do not agree with the definition of Automatic Reclosing, otherwise FAQ is okay.

Document Name:

Likes: 0

Dislikes: 0

Emily Rousseau - MRO - 1,2,3,4,5,6 - MRO

Group Information

Group Name: MRO-NERC Standards Review Forum (NSRF)

Group Member Name	Entity	Region	Segments
Joe Depoorter	Madison Gas & Electric	MRO	3,4,5,6
Amy Casucelli	Xcel Energy	MRO	1,3,5,6
Chuck Lawrence	American Transmission Company	MRO	1
Chuck Wicklund	Otter Tail Power Company	MRO	1,3,5
Theresa Allard	Minnkota Power Cooperative, Inc	MRO	1,3,5,6
Dave Rudolph	Basin Electric Power Cooperative	MRO	1,3,5,6
Kayleigh Wilkerson	Lincoln Electric System	MRO	1,3,5,6
Jodi Jenson	Western Area Power Administration	MRO	1,6
Larry Heckert	Alliant Energy	MRO	4
Mahmood Safi	Omaha Public Utility District	MRO	1,3,5,6
Marie Knox	Midwest ISO Inc.	MRO	2
Mike Brytowski	Great River Energy	MRO	1,3,5,6
Randi Nyholm	Minnesota Power	MRO	1,5
Scott Nickels	Rochester Public Utilities	MRO	4
Terry Harbour	MidAmerican Energy Company	MRO	1,3,5,6
Tom Breene	Wisconsin Public Service Corporation	MRO	3,4,5,6
Tony Eddleman	Nebraska Public Power District	MRO	1,3,5

Voter Information

Voter	Segment
Emily Rousseau	1,2,3,4,5,6
Entity	Region(s)
MRO	MRO

Selected Answer: Yes

Answer Comment:

Document Name:

Likes: 0

Dislikes: 0

Stanley Beasley - Georgia Transmission Corporation - 1 - SERC

Selected Answer: Yes

Answer Comment:

On page 103, the bullet "27 or 59 – supervisory contact from a undervoltage of overvoltage" has a typo. "of" should be "or". Also, please see SERC PCS comments.

Document Name:

Likes: 0

Dislikes: 0

Molly Devine - IDACORP - Idaho Power Company - 1 -

Selected Answer: Yes

Answer Comment:

Document Name:

Likes: 0

Dislikes: 0

Venona Greaff - Oxy - Occidental Chemical - 7 -

Selected Answer: Yes

Answer Comment:

Document Name:

Likes: 0

Dislikes: 0

Jeri Freimuth - APS - Arizona Public Service Co. - 1,3,5,6 - WECC

Selected Answer: No

Answer Comment:

Excitation and voltage regulating systems should not be classified as Protection Systems, rather these should more accurately be classified as control systems with protection functionality. AZPS recommends removing the guidance that would include these devices within this standard.

Document Name:

Likes: 0

Dislikes: 0

David Greene - SERC Reliability Corporation - 1 - SERC

Group Information

Group Name: SERC PCS

Group Member Name	Entity	Region	Segments
Paul Nauert	Ameren	SERC	1
Charlie Fink	Entergy	SERC	1
David Greene	SERC staff	SERC	10

Voter Information

Voter David Greene **Segment** 1

Entity SERC Reliability Corporation **Region(s)** SERC

Selected Answer: Yes

Answer Comment:

1) NERC Glossary defines "Control circuitry associated with protective functions through the trip coil(s) of the circuit breakers or other interrupting devices." But Control circuitry is also one of the Components for Automatic Reclosing, which is a control function. For protective functions the extent of the 'Control circuitry' is clear. For Automatic Reclosing it is not as clear.

Please add another FAQ in section 15.8.1: 'What Control circuitry for Automatic Reclosing must be maintained?'

Answer: As noted on page 12 of the SAMS/SPCS report, the concern being addressed within the standard is premature auto reclosing that has the potential to cause generating unit or plant instability. Responsible entities will need to verify all parts of the Control circuitry that could cause a premature closing command to the breaker close circuitry. Permissive or supervisory contacts like device 86b, 43 control switch, or 79 cutoff, and the breaker anti-pump circuitry are generally outside of the intended Control circuitry, and would not need to be verified. The wiring connecting the supervisory devices 25, 27 or 59 to Automatic Reclosing device 79 is generally within the intended Control circuitry, and would need to be verified.'

2) Change the page 110 Figure 1 & 2 Legend – Components of Protection Systems as follows:

For row 2 state 'including most sync check systems' in the Excludes column rather than deleting 'sync check systems'. PRC-005-6 will only include a few sync check systems;

3) Also add or clearly identify the control circuitry for automatic reclosing, supervisory relay and voltage sensing devices to Figure 1 to help identify the applicable circuitry. This could be a separate figure identifying these components if not feasible to add to Figure 1.

Document Name:

Likes: 0

Dislikes: 0

Rachel Coyne - Texas Reliability Entity, Inc. - 10 -

Selected Answer: No

Answer Comment: Texas RE noticed the document references PRC-005-4. Is this correct? PRC-005-6 is only referenced once on a "Requirements Flowchart" diagram on page 23.

Document Name:

Likes: 0

Dislikes: 0

David Jendras - Ameren - Ameren Services - 3 -

Selected Answer: Yes

Answer Comment: Ameren supports and agrees with the SERC PCS / Region – Project-2015-05 PRC-005-06 FERC Order 803 Comments for Question #4 and includes them by reference.

Document Name:

Likes: 0

Dislikes: 0

Lee Pedowicz - Northeast Power Coordinating Council - 10 - NPCC

Group Information

Group Name: NPCC--Project 2007-17.4

Group Member Name	Entity	Region	Segments
Alan Adamson	New York State Reliability Council, LLC	NPCC	10
David Burke	Orange and Rockland Utilities Inc.	NPCC	3
Greg Campoli	New York Independent System Operator	NPCC	2
Sylvain Clermont	Hydro-Quebec TransEnergie	NPCC	1
Kelly Dash	Consolidated Edison Co. of New York, Inc.	NPCC	1
Gerry Dunbar	Northeast Power Coordinating Council	NPCC	10
Mark Kenny	Northeast Utilities	NPCC	1
Helen Lainis	Independent Electricity System Operator	NPCC	2
Alan MacNaughton	New Brunswick Power Corporation	NPCC	9
Paul Malozewski	Hydro One Networks Inc.	NPCC	1
Bruce Metruck	New York Power Authority	NPCC	6
Lee Pedowicz	Northeast Power Coordinating Council	NPCC	10
Robert Pellegrini	The United Illuminating Company	NPCC	1
Si Truc Phan	Hydro-Quebec TransEnergie	NPCC	1
David Ramkalawan	Ontario Power Generation, Inc.	NPCC	5
Brian Robinson	Utility Services	NPCC	8
Wayne Sipperly	New York Power Authority	NPCC	5
Edward Bedder	Orange and Rockland Utilities Inc.	NPCC	1
Peter Yost	Consolidated Edison Co. of New York, Inc.	NPCC	3
Michael Jones	National Grid	NPCC	1

Brian Shanahan	National Grid	NPCC	1
Michael Forte	Consolidated Edison Co. of New York, Inc.	NPCC	1
Glen Smith	Entergy Services, Inc.	NPCC	5
Brian O'Boyle	Consolidated Edison Co. of New York, Inc.	NPCC	8
RuiDa Shu	Northeast Power Coordinating Council	NPCC	10
Connie Lowe	Dominion Resources Services, Inc.	NPCC	5
Guy Zito	Northeast Power Coordinating Council	NPCC	10
Silvia Parada Mitchell	NextEra Energy, LLC	NPCC	5

Voter Information

Voter	Segment
Lee Pedowicz	10
Entity	Region(s)
Northeast Power Coordinating Council	NPCC

Selected Answer:

Answer Comment:

From page 7 of the Supplementary Reference and FAQ Document:

“What is synchronizing or synchronism (Sync-Check - (25)) - check relay (Sync-Check - 25)?

A synchronizing device that produces an output that supervises closure of a circuit breaker between two circuits whose voltages are within prescribed limits of magnitude and, phase angle. It may or may not include voltage or speed control. A sync-check relay permits the paralleling of two circuits that are within prescribed (usually wider) limits of voltage magnitude and, phase angle.”

Suggest replacing “paralleling” with “connecting”.

From page 106:

“Is it necessary to verify the close signal operates the breaker?”

Only when the control circuitry associated with automatic reclosing is a part of a RAS, then all paths that are essential for proper operation of the RAS must be verified, per table 4-2(b)."

It is good practice when testing to ensure that a close signal operates a breaker regardless of whether it is part of a RAS or not.

Document Name:

Likes: 0

Dislikes: 0

Oliver Burke - Entergy - Entergy Services, Inc. - 1 -

Selected Answer: Yes

Answer Comment: Entergy supports comments by SERC PCS group.

Document Name:

Likes: 0

Dislikes: 0

Dennis Chastain - Tennessee Valley Authority - 1,3,5,6 - SERC

Selected Answer: Yes

Answer Comment: 1) The NERC Glossary of Terms definition for Protection System includes “Control circuitry associated with protective functions through the trip coil(s) of the circuit breakers or other interrupting devices.” Control circuitry is also one of the Component Types listed in the Automatic Reclosing definition, which is a control function. For protective functions the extent of the ‘Control circuitry’ is clear, but for Automatic Reclosing it is not as clear. Please add the following FAQ / response to section 15.8.1 to help clarify:

Question: ‘What Control circuitry for Automatic Reclosing must be maintained?’

Answer: As noted on page 12 of the SAMS/SPCS report, the concern being addressed within the standard is premature auto reclosing that has the potential to cause generating unit or plant instability. Responsible entities will need to verify all parts of the Control circuitry that could cause a premature closing command to the breaker close circuitry. Permissive or supervisory contacts like device 86b, 43 control switch, or 79 cutoff, and the breaker anti-pump circuitry are generally outside of the intended Control circuitry, and would not need to be verified. The wiring connecting the supervisory devices 25, 27 or 59 to Automatic Reclosing device 79 is generally within the intended Control circuitry, and would need to be verified.’

2) Please change the page 110 “Figure 1 & 2 Legend – Components of Protection Systems” table as follows:

For row 2, replace the strikethrough with ‘including most sync check systems’ in the Excludes column rather than deleting ‘sync check systems’. PRC-005-6 will only include a few sync check systems.

3) Please add or clearly identify the control circuitry for automatic reclosing, supervisory relay and voltage sensing devices to Figure 1 to help identify the applicable circuitry. This could be a separate figure identifying these components if not feasible to add to Figure 1.

Document Name:

Likes: 0

Dislikes: 0

Oshani Pathirane - Hydro One Networks, Inc. - 1,3 - NPCC

Selected Answer: No

Answer Comment:

In the definition of a synchronizing device, Hydro One agrees with the NPCC TFSP in that the word “paralleling” used to describe the closing effect of connecting two circuits upon the close of a circuit breaker should perhaps be replaced by “connecting” .

Document Name:

Likes: 0

Dislikes: 0

Payam Farahbakhsh - Hydro One Networks, Inc. - 1 -

Selected Answer: No

Answer Comment:

Document Name:

Likes: 0

Dislikes: 0

Jason Smith - Southwest Power Pool, Inc. (RTO) - 2 - MRO,SPP

Group Information

Group Name: SPP Standards Review Group

Group Member Name	Entity	Region	Segments
Shannon Mickens	Southwest Power Pool	SPP	2
James Nail	City of Independence, Missouri	SPP	3,5
Jamison Cawley	Nebraska Public Power District	MRO	1,3,5
Robert Hirschak	Cleco Power	SPP	1,3,5,6
Mike Kidwell	Empire District Electric	SPP	1,3,5
Jason Smith	Southwest Power Pool	SPP	2
Ashley Stringer	Oklahoma Municipal Power Authority	SPP	4
J. Scott Williams	City Utilities of Springfield	SPP	1,4
Ellen Watkins	Sunflower Electric Power Corporation	SPP	1

Voter Information

Voter	Segment
Jason Smith	2
Entity	Region(s)
Southwest Power Pool, Inc. (RTO)	MRO,SPP

Selected Answer: Yes

Answer Comment:

Document Name:

Likes: 0

Dislikes: 0

Leonard Kula - Independent Electricity System Operator - 2 -

Selected Answer:

Answer Comment:

Document Name:

Likes: 0

Dislikes: 0

Colby Bellville - Duke Energy - 1,3,5,6 - FRCC,SERC,RFC

Group Information

Group Name: Duke Energy

Group Member Name	Entity	Region	Segments
Doug Hils	Duke Energy	RFC	1
Lee Schuster	Duke Energy	FRCC	3
Dale Goodwine	Duke Energy	SERC	5
Greg Cecil	Duke Energy	RFC	6

Voter Information

Voter	Segment
Colby Bellville	1,3,5,6
Entity	Region(s)
Duke Energy	FRCC,SERC,RFC

Selected Answer: No

Answer Comment:

Duke Energy is of the belief that the addition made on page 26-27 of the Supplementary Reference Document concerning the protection function that is embedded in a Generator’s voltage regulator, appears to be a significant change/addition to the established scope of the standard. If an expansion of the scope of the standard was the intent of the addition, we recommend that a revision be made to Section 2.4 “Applicable Relays”. The existing verbiage in Section 2.4 is not sufficiently clear that a generator exciter or generator voltage regulator can be a relay. The variants of the term relay includes electromechanical relay, numerical relay, microprocessor relay, sudden pressure relay, reclosing relay, others and now generator exciter and generator voltage regulator. Additionally, Duke recommends that a change of this significance, if an expansion of scope was intended, be included in a revision of the PRC-005 standard itself in Section 4.2 “Facilities” with associated implementation, and not addressed in a Supplementary Reference Document.

Also, Duke Energy suggests that clarification is needed regarding the following question and answer that has been added on page 107 of the Supplementary Reference and FAQ Document. The question is as follows:

“My reclosing circuitry contains the following inputs listed below; what supervising relays would need to be tested per PRC-005?”

We feel that the question is a bit confusing/misleading, and seems to mix subject matter. Is it the drafting team’s intent that the control circuitry must also be tested in the example? If so, should the control circuitry be added to the answer given? If it was the drafting team’s intent to separate the supervisory relays from the control circuitry, then the answer would appear to be appropriate, but the question appears to mix the two. Combining supervisory relays with control circuitry and not keeping them separate, as they have been in parts of the standard, may lead to confusion amongst industry stakeholders.

Document Name:

Likes: 1 Tallahassee Electric (City of Tallahassee, FL), 5, Webb Karen

Dislikes: 0

Scott Langston - Tallahassee Electric (City of Tallahassee, FL) - 1 -

Selected Answer: No

Answer Comment:

Page 26 of the FAQ seemingly expands the testing and maintenance requirements of PRC-005 to include generator components that have not previously been the subject of PRC-005. It is not clear what gap in reliability exists between the testing of the generator relays that is currently required under existing standards and the generator control systems referenced in the FAQ. Additionally, if the scope of PRC-005 is to be expanded, an FAQ document is not the appropriate instrument to do so.

Document Name:

Likes: 2 Tallahassee Electric (City of Tallahassee, FL), 5, Webb Karen
Tallahassee Electric (City of Tallahassee, FL), 3, Williams John

Dislikes: 0

Karen Webb - Tallahassee Electric (City of Tallahassee, FL) - 5 -

Selected Answer: No

Answer Comment:

Page 26 of the FAQ seemingly expands the testing and maintenance requirements of PRC-005 to include generator components that have not previously been the subject of PRC-005. It is not clear what gap in reliability exists between the testing of the generator relays that is currently required under existing standards and the generator control systems referenced in the FAQ. Additionally, if the scope of PRC-005 is to be expanded, an FAQ document is not the appropriate instrument to do so.

Document Name:

Likes: 2 Tallahassee Electric (City of Tallahassee, FL), 3, Williams John
Tallahassee Electric (City of Tallahassee, FL), 1, Langston Scott

Dislikes: 0

John Williams - Tallahassee Electric (City of Tallahassee, FL) - 3 -

Selected Answer: No

Answer Comment:

Document Name:

Likes: 0

Dislikes: 0

John Merrell - Tacoma Public Utilities (Tacoma, WA) - 1 -

Selected Answer: No

Answer Comment:

On pages 26-27 of the redlined version of the Supplementary Reference and FAQ, do not add the paragraphs regarding protection functions that are embedded in a Generator's voltage regulator. This addition is inconsistent with the purpose of the proposed SAR. Furthermore, it is unclear how many in the industry interpreted a voltage regulator or excitation system, or elements thereof, as a protective relay when the industry previously balloted the current definition of a Protection System.

Document Name:

Likes: 0

Dislikes: 0

Andrea Jessup - Bonneville Power Administration - 1,3,5,6 - WECC

Selected Answer: Yes

Answer Comment:

Document Name:

Likes: 0

Dislikes: 0

5. The PSMTSDT has proposed combining the Implementation Plans for previous versions of PRC-005 (including PRC-005-3, PRC-005-3i, PRC-005-3ii, PRC-005-4 and PRC-005-5). Do you agree with the proposed Implementation Plan? If not, please provide specific comments regarding the Implementation Plan and any suggestions for alternative language.

John Fontenot - Bryan Texas Utilities - 1 -

Selected Answer: Yes

Answer Comment:

Document Name:

Likes: 0

Dislikes: 0

Thomas Foltz - AEP - 5 -

Selected Answer:

Answer Comment:

Document Name:

Likes: 0

Dislikes: 0

Kaleb Brimhall - Colorado Springs Utilities - 5 -

Selected Answer: Yes

Answer Comment:

We agree with the PSMTSDT on combining the Implementation Plans for the previous versions of PRC-005. However, we request that NERC formally recommend that FERC delay the enforcement of the earlier versions of this standard until PRC-005-6 has been finalized (balloted and implemented) in the NERC Standards Development Process. In our opinion, the various versions of this standard has caused confusion amongst the industry on what goals need to be accomplished by each of the drafting teams assigned to the development of the respective standards. We firmly believe that this suggested approach will be productive and efficient in getting all goals met in the standards development process especially, in reference to this particular family of standards.

Finally, we would suggest to the drafting team in reference all the newly defined terms added to PRC-005-6 that they ensure these terms are included into

relevant documentation such as: The NERC Glossary of Terms, and Rules of Procedure (RoP) so they will be aligned properly.

Document Name:

Likes: 0

Dislikes: 0

Gul Khan - Oncor Electric Delivery - 2 - TRE

Selected Answer: Yes

Answer Comment:

Document Name:

Likes: 0

Dislikes: 0

Maryclaire Yatsko - Seminole Electric Cooperative, Inc. - 1,3,4,5,6 - FRCC

Selected Answer: No

Answer Comment:

There is an inconsistency in the use of April 1st and January 1st dates for compliance. The January 1st dates eliminate at least one full quarter of time allowed for compliance maintenance activities. All references to January 1st dates in the implementation plan should be changed to April 1st dates for items 2, 3, 4, and 5 on page 6 of the Implementation Plan.

Document Name:

Likes: 0

Dislikes: 0

Mike Smith - Manitoba Hydro - 1 -

Selected Answer: Yes

Answer Comment:

Document Name:

Likes: 0

Dislikes: 0

Andrew Puztai - American Transmission Company, LLC - 1 -

Selected Answer: Yes

Answer Comment:

Document Name:

Likes: 0

Dislikes: 0

Chris Scanlon - Exelon - 1 -

Group Information

Group Name: Exelon Utilities

Group Member Name	Entity	Region	Segments
Chris Scanlon	BGE, ComEd, PECO TO's	RFC	1
John Bee	BGE, ComEd, PECO LSE's	RFC	3

Voter Information

Voter	Segment
Chris Scanlon	1
Entity	Region(s)
Exelon	

Selected Answer: Yes

Answer Comment:

We strongly agree with combining the Implementation Plans for the various versions of PRC-005.

Other Comments: We are providing a comment about a section of PRC-005 not directly related to the SAR. We find the wording of the exclusion for 4.2.7.1 & 4.2.7.2 to be very confusing, and don't understand the basis for it. Automatic Reclosing addressed in Section 4.2.7.1 and 4.2.7.2 may be excluded if the equipment owner can demonstrate that a close-in three-phase fault present for twice the normal clearing time (capturing a minimum trip-close-trip time delay) does not result in a total loss of gross generation in the Interconnection exceeding the gross capacity of the largest relevant BES generating unit where the Automatic Reclosing is applied. As we understand it, normal clearing time at a generating station is typically 4 to 5 cycles. There may be some exceptions for faults on certain lines, but in general a 3-phase fault lasting 8 to 10 cycles would likely result in units at generating plant to be unstable.

Document Name:

Likes: 0

Dislikes: 0

Emily Rousseau - MRO - 1,2,3,4,5,6 - MRO

Group Information

Group Name: MRO-NERC Standards Review Forum (NSRF)

Group Member Name	Entity	Region	Segments
Joe Depoorter	Madison Gas & Electric	MRO	3,4,5,6
Amy Casucelli	Xcel Energy	MRO	1,3,5,6
Chuck Lawrence	American Transmission Company	MRO	1
Chuck Wicklund	Otter Tail Power Company	MRO	1,3,5
Theresa Allard	Minnkota Power Cooperative, Inc	MRO	1,3,5,6
Dave Rudolph	Basin Electric Power Cooperative	MRO	1,3,5,6
Kayleigh Wilkerson	Lincoln Electric System	MRO	1,3,5,6
Jodi Jenson	Western Area Power Administration	MRO	1,6
Larry Heckert	Alliant Energy	MRO	4
Mahmood Safi	Omaha Public Utility District	MRO	1,3,5,6
Marie Knox	Midwest ISO Inc.	MRO	2
Mike Brytowski	Great River Energy	MRO	1,3,5,6
Randi Nyholm	Minnesota Power	MRO	1,5
Scott Nickels	Rochester Public Utilities	MRO	4
Terry Harbour	MidAmerican Energy Company	MRO	1,3,5,6
Tom Breene	Wisconsin Public Service Corporation	MRO	3,4,5,6
Tony Eddleman	Nebraska Public Power District	MRO	1,3,5

Voter Information

Voter	Segment
Emily Rousseau	1,2,3,4,5,6
Entity	Region(s)
MRO	MRO

Selected Answer: Yes

Answer Comment:

NSRF strongly supports the proposal to align the Implementation Plans for the previous versions of PRC-005 into a single PRC-005-6 Implementation Plan. A single implementation plan will help the industry avoid tracking and maintaining multiple implementation and completion schedules associated with each component type is added when each version becomes effective. NSRF appreciates PSMTSDT's effort on this proposal.

Document Name:**Likes:** 0**Dislikes:** 0

Stanley Beasley - Georgia Transmission Corporation - 1 - SERC

Selected Answer: Yes

Answer Comment:

Balancing Authority should be removed from the SAR as one of the applicable entities since the standard does not apply to the BA.

We also disagree with the general considerations section on page 3 because it states that “each registered entity must be prepared to identify...Automatic Reclosing and Sudden Pressure Relaying” while implementing PRC-005-2. These items were added in PRC-005-3 and PRC-005-4. As a result, in accordance with the implementation plan, identification would not be required until these requirements became effective as a part of PRC-005-6.

While we agree with the concept of the combined implementation plan, we believe clarity could be added to the implementation plan. Since PRC-005-6 will simply supersede all revisions inclusive of PRC-005-2 onward (including all revisions of PRC-005-3, PRC-005-4, and PRC-005-5), a single reference to the PRC-005-2 implementation plan could greatly simplify the proposed PRC-005-6 implementation plan. For example, something along the lines of “**All Components with existing requirements under PRC-005-2 will continue to follow the PRC-005-2 implementation plan. Those Components and/or Facilities newly introduced by PRC-005-6 (including Sudden Pressure Relaying, Automatic Reclosing Components, and Distributed Generation Resources) will be covered by the following implementation plan:**” followed by the timelines laid out beneath each PRC-005-6 heading in the existing implementation plan draft. We believe such wording would provide some improved clarity. Also, please see SERC PCS comments.

Document Name:

Likes: 0

Dislikes: 0

Molly Devine - IDACORP - Idaho Power Company - 1 -

Selected Answer: Yes

Answer Comment:

Document Name:

Likes: 0

Dislikes: 0

Venona Greaff - Oxy - Occidental Chemical - 7 -

Selected Answer: Yes

Answer Comment:

OCC supports the project team's proposal to consolidate the implementation plans for the five in-process PRC-005 standards. We believe that without a combined implementation plan, extensive confusion could result as each version independently takes effect. OCC finds the consolidated implementation plan to be clear and the time frames reasonable.

Document Name:

Likes: 0

Dislikes: 0

Jeri Freimuth - APS - Arizona Public Service Co. - 1,3,5,6 - WECC

Selected Answer: Yes

Answer Comment:

Document Name:

Likes: 0

Dislikes: 0

David Greene - SERC Reliability Corporation - 1 - SERC

Group Information

Group Name: SERC PCS

Group Member Name	Entity	Region	Segments
Paul Nauert	Ameren	SERC	1
Charlie Fink	Entergy	SERC	1
David Greene	SERC staff	SERC	10

Voter Information

Voter David Greene **Segment** 1

Entity SERC Reliability Corporation **Region(s)** SERC

Selected Answer: Yes

Answer Comment:

We agree with the PSMTSDT on combining the Implementation Plans for the previous versions of PRC-005 (including PRC-005-3, PRC-005-3i, PRC-005-3ii, PRC-005-4 and PRC-005-5). We are concerned that FERC approval will occur too late to avert PRC-005-3 implementation, which is effective 4/1/2016. The SDT timeline is to file PRC-005-6 with FERC in December 2015. Therefore, we request that NERC formally recommend that FERC delay the enforcement of the earlier versions of this standard until PRC-005-6 has been finalized (balloted and implemented) in the NERC Standards Development Process. In our opinion, the various versions of this standard has caused confusion amongst the industry on what goals need to be accomplished by each of the drafting teams assigned to the development of the respective standards. We firmly believe that this suggested approach will be productive and efficient in getting all goals met in the standards development process especially, in reference to this particular family of standards.

The comments expressed herein represent a consensus of the views of the above-named members of the SERC EC Protection and Control Subcommittee

only and should not be construed as the position of SERC Reliability Corporation, its board, or its officers.

Document Name:

Likes: 0

Dislikes: 0

Rachel Coyne - Texas Reliability Entity, Inc. - 10 -

Selected Answer: No

Answer Comment: Texas RE noticed the Implementation Plan has no reference to Table 4-3 implementation requirements.

Document Name:

Likes: 0

Dislikes: 0

David Jendras - Ameren - Ameren Services - 3 -

Selected Answer: Yes

Answer Comment:

While we do agree, we are concerned that FERC approval will occur too late to avert PRC-005-3 implementation, which is effective 4/1/2016. The SDT timeline is to file PRC-005-6 with FERC in December 2015. Furthermore, since we prefer to begin a Calendar Year on January 1st our plan is to begin PRC-005-3 on 1/1/2016.

Document Name:

Likes: 0

Dislikes: 0

Lee Pedowicz - Northeast Power Coordinating Council - 10 - NPCC

Group Information

Group Name: NPCC--Project 2007-17.4

Group Member Name	Entity	Region	Segments
Alan Adamson	New York State Reliability Council, LLC	NPCC	10
David Burke	Orange and Rockland Utilities Inc.	NPCC	3
Greg Campoli	New York Independent System Operator	NPCC	2
Sylvain Clermont	Hydro-Quebec TransEnergie	NPCC	1
Kelly Dash	Consolidated Edison Co. of New York, Inc.	NPCC	1
Gerry Dunbar	Northeast Power Coordinating Council	NPCC	10
Mark Kenny	Northeast Utilities	NPCC	1
Helen Lainis	Independent Electricity System Operator	NPCC	2
Alan MacNaughton	New Brunswick Power Corporation	NPCC	9
Paul Malozewski	Hydro One Networks Inc.	NPCC	1
Bruce Metruck	New York Power Authority	NPCC	6
Lee Pedowicz	Northeast Power Coordinating Council	NPCC	10
Robert Pellegrini	The United Illuminating Company	NPCC	1
Si Truc Phan	Hydro-Quebec TransEnergie	NPCC	1
David Ramkalawan	Ontario Power Generation, Inc.	NPCC	5
Brian Robinson	Utility Services	NPCC	8
Wayne Sipperly	New York Power Authority	NPCC	5
Edward Bedder	Orange and Rockland Utilities Inc.	NPCC	1
Peter Yost	Consolidated Edison Co. of New York, Inc.	NPCC	3
Michael Jones	National Grid	NPCC	1

Brian Shanahan	National Grid	NPCC	1
Michael Forte	Consolidated Edison Co. of New York, Inc.	NPCC	1
Glen Smith	Entergy Services, Inc.	NPCC	5
Brian O'Boyle	Consolidated Edison Co. of New York, Inc.	NPCC	8
RuiDa Shu	Northeast Power Coordinating Council	NPCC	10
Connie Lowe	Dominion Resources Services, Inc.	NPCC	5
Guy Zito	Northeast Power Coordinating Council	NPCC	10
Silvia Parada Mitchell	NextEra Energy, LLC	NPCC	5

Voter Information

Voter	Segment
Lee Pedowicz	10
Entity	Region(s)
Northeast Power Coordinating Council	NPCC

Selected Answer: Yes

Answer Comment:

Document Name:

Likes: 0

Dislikes: 0

Oliver Burke - Entergy - Entergy Services, Inc. - 1 -

Selected Answer: Yes

Answer Comment: Entergy supports comments by SERC PCS group.

Document Name:

Likes: 0

Dislikes: 0

Dennis Chastain - Tennessee Valley Authority - 1,3,5,6 - SERC

Selected Answer: Yes

Answer Comment: We agree with the PSMTSDT on combining the Implementation Plans for the previous versions of PRC-005 (including PRC-005-3, PRC-005-3i, PRC-005-3ii, PRC-005-4 and PRC-005-5). We are concerned that FERC approval will occur too late to avert PRC-005-3 implementation, which is effective 4/1/2016. The SDT timeline is to file PRC-005-6 with FERC in December 2015. Therefore, we request that NERC formally recommend that FERC delay the enforcement of the earlier versions of this standard until PRC-005-6 has been finalized (balloted and implemented) in the NERC Standards Development Process. In our opinion, the various versions of this standard has caused confusion within the industry on what goals need to be accomplished by each of the drafting teams assigned to the development of the respective standards. We firmly believe that this suggested approach will be productive and efficient in getting all goals met in the standards development process, especially with respect to this collection of standards.

Document Name:

Likes: 0

Dislikes: 0

Oshani Pathirane - Hydro One Networks, Inc. - 1,3 - NPCC

Selected Answer: Yes

Answer Comment:

Hydro One also agrees with the IESO (Ontario) that although we generally agree with combining the subsequent Implementation Plans, we would like to reserve our judgment when the standard and its Implementation Plan are re-posted for formal comments and balloting.

Document Name:

Likes: 0

Dislikes: 0

Payam Farahbakhsh - Hydro One Networks, Inc. - 1 -

Selected Answer: Yes

Answer Comment:

Document Name:

Likes: 0

Dislikes: 0

Jason Smith - Southwest Power Pool, Inc. (RTO) - 2 - MRO,SPP

Group Information

Group Name: SPP Standards Review Group

Group Member Name	Entity	Region	Segments
Shannon Mickens	Southwest Power Pool	SPP	2
James Nail	City of Independence, Missouri	SPP	3,5
Jamison Cawley	Nebraska Public Power District	MRO	1,3,5
Robert Hirschak	Cleco Power	SPP	1,3,5,6
Mike Kidwell	Empire District Electric	SPP	1,3,5
Jason Smith	Southwest Power Pool	SPP	2
Ashley Stringer	Oklahoma Municipal Power Authority	SPP	4
J. Scott Williams	City Utilities of Springfield	SPP	1,4
Ellen Watkins	Sunflower Electric Power Corporation	SPP	1

Voter Information

Voter	Segment
Jason Smith	2
Entity	Region(s)
Southwest Power Pool, Inc. (RTO)	MRO,SPP

Selected Answer: Yes

Answer Comment:

We agree with the PSMTSDT on combining the Implementation Plans for the previous versions of PRC-005. However, we request that NERC formally recommend that FERC delay the enforcement of the earlier versions of this standard until PRC-005-6 has been finalized (balloted and implemented) in the NERC Standards Development Process. In our opinion, the various versions of this standard has caused confusion amongst the industry on what goals need to be accomplished by each of the drafting teams assigned to the development of the respective standards. We firmly believe that this suggested approach will be productive and efficient in getting all goals met in the standards development process, especially in reference to this particular family of standards.

Finally, we would suggest the drafting team review all the newly defined terms added to PRC-005-6 in order to ensure these terms are included in relevant documentation such as The NERC Glossary of Terms and Rules of Procedure (RoP) so they will be aligned properly.

Document Name:

Likes: 0

Dislikes: 0

Leonard Kula - Independent Electricity System Operator - 2 -

Selected Answer: Yes

Answer Comment:

We generally agree with the proposed implementation plan, but reserve our judgment when the standard and its implementation plan are posted for formal comment and balloting. Note that the March 31, 2027 date throughout the Implementation Plan document could be a typo.

Document Name:

Likes: 0

Dislikes: 0

Colby Bellville - Duke Energy - 1,3,5,6 - FRCC,SERC,RFC

Group Information

Group Name: Duke Energy

Group Member Name	Entity	Region	Segments
Doug Hils	Duke Energy	RFC	1
Lee Schuster	Duke Energy	FRCC	3
Dale Goodwine	Duke Energy	SERC	5
Greg Cecil	Duke Energy	RFC	6

Voter Information

Voter	Segment
Colby Bellville	1,3,5,6
Entity	Region(s)
Duke Energy	FRCC,SERC,RFC

Selected Answer: Yes

Answer Comment:

Document Name:

Likes: 0

Dislikes: 0

Scott Langston - Tallahassee Electric (City of Tallahassee, FL) - 1 -

Selected Answer: Yes

Answer Comment:

Document Name:

Likes: 0

Dislikes: 0

Karen Webb - Tallahassee Electric (City of Tallahassee, FL) - 5 -

Selected Answer: Yes

Answer Comment:

Document Name:

Likes: 0

Dislikes: 0

John Williams - Tallahassee Electric (City of Tallahassee, FL) - 3 -

Selected Answer: Yes

Answer Comment:

Document Name:

Likes: 0

Dislikes: 0

John Merrell - Tacoma Public Utilities (Tacoma, WA) - 1 -

Selected Answer: Yes

Answer Comment:

Document Name:

Likes: 0

Dislikes: 0

Andrea Jessup - Bonneville Power Administration - 1,3,5,6 - WECC

Selected Answer: Yes

Answer Comment:

Document Name:

Likes: 0

Dislikes: 0

Standard Development Timeline

This section is maintained by the drafting team during the development of the standard and will be removed when the standard becomes effective.

Development Steps Completed

1. SAR posted for comment March 12 – April 10, 2015.
2. Revised SAR reposted with revisions for comment June 11 – July 10, 2015

Description of Current Draft

This version of PRC-005 was posted for a 45-day concurrent comment and ballot period to address directives from [FERC Order No. 803](#), addressing Automatic Reclosing. Specifically, supervisory relays, associated voltage sensing devices, and associated control circuitry were added.

Anticipated Actions	Anticipated Dates
45-day Formal Comment Period with Concurrent Ballot	July 2015 – September 2015
Final ballot	October 2015
BOT adoption	November 2015

Definitions of Terms Used in Standard

This section includes all newly defined or revised terms used in the proposed standard. Terms already defined in the Reliability Standards Glossary of Terms (Glossary) are not repeated here. New or revised definitions listed below become approved when the proposed standard is approved. When the standard becomes effective, this defined term will be removed from the individual standard and added to the Glossary.

[See Section 6 of the Standard](#)

A. Introduction

1. **Title:** Protection System, Automatic Reclosing, and Sudden Pressure Relaying Maintenance
2. **Number:** PRC-005-6
3. **Purpose:** To document and implement programs for the maintenance of all Protection Systems, Automatic Reclosing, and Sudden Pressure Relaying affecting the reliability of the Bulk Electric System (BES) so that they are kept in working order.
4. **Applicability:**
 - 4.1. **Functional Entities:**
 - 4.1.1 Transmission Owner
 - 4.1.2 Generator Owner
 - 4.1.3 Distribution Provider
 - 4.2. **Facilities:**
 - 4.2.1 Protection Systems and Sudden Pressure Relaying that are installed for the purpose of detecting Faults on BES Elements (lines, buses, transformers, etc.)
 - 4.2.2 Protection Systems used for underfrequency load-shedding systems installed per ERO underfrequency load-shedding requirements.
 - 4.2.3 Protection Systems used for undervoltage load-shedding systems installed to prevent system voltage collapse or voltage instability for BES reliability.
 - 4.2.4 Protection Systems installed as a Remedial Action Scheme (RAS) for BES reliability.
 - 4.2.5 Protection Systems and Sudden Pressure Relaying for generator Facilities that are part of the BES, except for generators identified through Inclusion I4 of the BES definition, including:
 - 4.2.5.1 Protection Systems that act to trip the generator either directly or via lockout or auxiliary tripping relays.
 - 4.2.5.2 Protection Systems and Sudden Pressure Relaying for generator step-up transformers for generators that are part of the BES.
 - 4.2.5.3 Protection Systems and Sudden Pressure Relaying for station service or excitation transformers connected to the generator bus of generators which are part of the BES, that act to trip the generator either directly or via lockout or tripping auxiliary relays.

4.2.6 Protection Systems and Sudden Pressure Relaying for the following BES generator Facilities for dispersed power producing resources identified through Inclusion I4 of the BES definition:

4.2.6.1 Protection Systems and Sudden Pressure Relaying for Facilities used in aggregating dispersed BES generation from the point where those resources aggregate to greater than 75 MVA to a common point of connection at 100kV or above.

4.2.7 Automatic Reclosing¹, including:

4.2.7.1 Automatic Reclosing applied on the terminals of Elements connected to the BES bus located at generating plant substations where the total installed gross generating plant capacity is greater than the gross capacity of the largest BES generating unit within the Balancing Authority Area or, if a member of a Reserve Sharing Group, the largest generating unit within the Reserve Sharing Group.²

4.2.7.2 Automatic Reclosing applied on the terminals of all BES Elements at substations one bus away from generating plants specified in Section 4.2.7.1 when the substation is less than 10 circuit-miles from the generating plant substation.

4.2.7.3 Automatic Reclosing applied as an integral part of an RAS specified in Section 4.2.4.

5. Effective Date: See the Implementation Plan for this standard.

6. Definitions Used in this Standard:

¹ Automatic Reclosing addressed in Section 4.2.7.1 and 4.2.7.2 may be excluded if the equipment owner can demonstrate that a close-in three-phase fault present for twice the normal clearing time (capturing a minimum trip-close-trip time delay) does not result in a total loss of gross generation in the Interconnection exceeding the gross capacity of the largest relevant BES generating unit where the Automatic Reclosing is applied.

² The largest BES generating unit within the Balancing Authority Area or the largest generating unit within the Reserve Sharing Group, as applicable, is subject to change. As a result of such a change, the Automatic Reclosing Components subject to the standard could change effective on the date of such change.

Automatic Reclosing – Includes the following Components:

- Reclosing relay
- Supervisory relay(s) or function(s) – relay(s) or function(s) that perform voltage and/or sync check functions that enable or disable operation of the reclosing relay
- Voltage sensing devices associated with the supervisory relay(s)
- Control circuitry associated with the reclosing relay or supervisory relay(s)

Rationale for revisions to Automatic Reclosing: To address directives from FERC Order No. 803 addressing Automatic Reclosing, the definition for Automatic Reclosing was revised to add supervisory relays, the associated voltage sensing devices, and the associated control circuitry.

Sudden Pressure Relaying – A system that trips an interrupting device(s) to isolate the equipment it is monitoring and includes the following Components:

- Fault pressure relay – a mechanical relay or device that detects rapid changes in gas pressure, oil pressure, or oil flow that are indicative of Faults within liquid-filled, wire-wound equipment
- Control circuitry associated with a fault pressure relay

Unresolved Maintenance Issue – A deficiency identified during a maintenance activity that causes the Component to not meet the intended performance, cannot be corrected during the maintenance interval, and requires follow-up corrective action.

Segment – Components of a consistent design standard, or a particular model or type from a single manufacturer that typically share other common elements. Consistent performance is expected across the entire population of a Segment. A Segment must contain at least sixty (60) individual Components.

Component Type –

- Any one of the five specific elements of a Protection System.
- Any one of the four specific elements of Automatic Reclosing.
- Any one of the two specific elements of Sudden Pressure Relaying.

Rationale for revisions to Component Type: With the revision of the definition of Automatic Reclosing, there are four specific elements of this definition, rather than two as stated in the prior version.

Component – Any individual discrete piece of equipment included in a Protection System, Automatic Reclosing, or Sudden Pressure Relaying.

Countable Event – A failure of a Component requiring repair or replacement, any condition discovered during the maintenance activities in Tables 1-1 through 1-5, Table

3, Tables 4-1 through 4-3, and Table 5, which requires corrective action or a Protection System Misoperation attributed to hardware failure or calibration failure. Misoperations due to product design errors, software errors, relay settings different from specified settings, Protection System Component, Automatic Reclosing, or Sudden Pressure Relaying configuration or application errors are not included in Countable Events.

B. Requirements and Measures

- R1.** Each Transmission Owner, Generator Owner, and Distribution Provider shall establish a Protection System Maintenance Program (PSMP) for its Protection Systems, Automatic Reclosing, and Sudden Pressure Relaying identified in Section 4.2, Facilities. *[Violation Risk Factor: Medium] [Time Horizon: Operations Planning]*

The PSMP shall:

- 1.1.** Identify which maintenance method (time-based, performance-based per PRC-005 Attachment A, or a combination) is used to address each Protection System, Automatic Reclosing, and Sudden Pressure Relaying Component Type. All batteries associated with the station DC supply Component Type of a Protection System shall be included in a time-based program as described in Table 1-4 and Table 3.
- 1.2.** Include the applicable monitored Component attributes applied to each Protection System, Automatic Reclosing, and Sudden Pressure Relaying Component Type consistent with the maintenance intervals specified in Tables 1-1 through 1-5, Table 2, Table 3, Table 4-1 through 4-3, and Table 5 where monitoring is used to extend the maintenance intervals beyond those specified for unmonitored Protection System, Automatic Reclosing, and Sudden Pressure Relaying Components.
- M1.** Each Transmission Owner, Generator Owner and Distribution Provider shall have a documented PSMP in accordance with Requirement R1.

For each Protection System, Automatic Reclosing, and Sudden Pressure Relaying Component Type, the documentation shall include the type of maintenance method applied (time-based, performance-based, or a combination of these maintenance methods), and shall include all batteries associated with the station DC supply Component Types in a time-based program as described in Table 1-4 and Table 3. (Part 1.1)

For Component Types that use monitoring to extend the maintenance intervals, the responsible entity(s) shall have evidence for each Protection System, Automatic Reclosing, and Sudden Pressure Relaying Component Type (such as manufacturer's specifications or engineering drawings) of the appropriate monitored Component attributes as specified in Tables 1-1 through 1-5, Table 2, Table 3, Table 4-1 through 4-3, and Table 5. (Part 1.2)

- R2.** Each Transmission Owner, Generator Owner, and Distribution Provider that uses performance-based maintenance intervals in its PSMP shall follow the procedure established in PRC-005 Attachment A to establish and maintain its performance-based intervals. *[Violation Risk Factor: Medium] [Time Horizon: Operations Planning]*
- M2.** Each Transmission Owner, Generator Owner, and Distribution Provider that uses performance-based maintenance intervals shall have evidence that its current performance-based maintenance program(s) is in accordance with Requirement R2, which may include, but is not limited to, Component lists, dated maintenance records, and dated analysis records and results.
- R3.** Each Transmission Owner, Generator Owner, and Distribution Provider that utilizes time-based maintenance program(s) shall maintain its Protection System, Automatic Reclosing, and Sudden Pressure Relaying Components that are included within the time-based maintenance program in accordance with the minimum maintenance activities and maximum maintenance intervals prescribed within Tables 1-1 through 1-5, Table 2, Table 3, Table 4-1 through 4-3, and Table 5. *[Violation Risk Factor: High] [Time Horizon: Operations Planning]*
- M3.** Each Transmission Owner, Generator Owner, and Distribution Provider that utilizes time-based maintenance program(s) shall have evidence that it has maintained its Protection System, Automatic Reclosing, and Sudden Pressure Relaying Components included within its time-based program in accordance with Requirement R3. The evidence may include, but is not limited to, dated maintenance records, dated maintenance summaries, dated check-off lists, dated inspection records, or dated work orders.
- R4.** Each Transmission Owner, Generator Owner, and Distribution Provider that utilizes performance-based maintenance program(s) in accordance with Requirement R2 shall implement and follow its PSMP for its Protection System, Automatic Reclosing, and Sudden Pressure Relaying Components that are included within the performance-based program(s). *[Violation Risk Factor: High] [Time Horizon: Operations Planning]*
- M4.** Each Transmission Owner, Generator Owner, and Distribution Provider that utilizes performance-based maintenance intervals in accordance with Requirement R2 shall have evidence that it has implemented the PSMP for the Protection System, Automatic Reclosing, and Sudden Pressure Relaying Components included in its performance-based program in accordance with Requirement R4. The evidence may include, but is not limited to, dated maintenance records, dated maintenance summaries, dated check-off lists, dated inspection records, or dated work orders.
- R5.** Each Transmission Owner, Generator Owner, and Distribution Provider shall demonstrate efforts to correct identified Unresolved Maintenance Issues. *[Violation Risk Factor: Medium] [Time Horizon: Operations Planning]*
- M5.** Each Transmission Owner, Generator Owner, and Distribution Provider shall have evidence that it has undertaken efforts to correct identified Unresolved Maintenance Issues in accordance with Requirement R5. The evidence may include, but is not

limited to, work orders, replacement Component orders, invoices, project schedules with completed milestones, return material authorizations (RMAs) or purchase orders.

C. Compliance

1. Compliance Monitoring Process

1.1. Compliance Enforcement Authority

As defined in the NERC Rules of Procedure, “Compliance Enforcement Authority” means NERC or the Regional Entity in their respective roles of monitoring and enforcing compliance with the NERC Reliability Standards.

1.2. Evidence Retention

The following evidence retention periods identify the period of time an entity is required to retain specific evidence to demonstrate compliance. For instances where the evidence retention period specified below is shorter than the time since the last audit, the Compliance Enforcement Authority may ask an entity to provide other evidence to show that it was compliant for the full time period since the last audit.

The Transmission Owner, Generator Owner, and Distribution Provider shall each keep data or evidence to show compliance as identified below unless directed by its Compliance Enforcement Authority to retain specific evidence for a longer period of time as part of an investigation.

For Requirement R1, the Transmission Owner, Generator Owner, and Distribution Provider shall each keep its current dated PSMP, as well as any superseded versions since the preceding compliance audit, including the documentation that specifies the type of maintenance program applied for each Protection System, Automatic Reclosing, or Sudden Pressure Relaying Component Type.

For Requirement R2, Requirement R3, and Requirement R4, in cases where the interval of the maintenance activity is longer than the audit cycle, the Transmission Owner, Generator Owner, and Distribution Provider shall each keep documentation of the most recent performance of that maintenance activity for the Protection System, Automatic Reclosing, or Sudden Pressure Relaying Component. In cases where the interval of the maintenance activity is shorter than the audit cycle, documentation of all performances (in accordance with the tables) of that maintenance activity for the Protection System, Automatic Reclosing, or Sudden Pressure Relaying Component since the previous scheduled audit date shall be retained.

For Requirement R5 the Transmission Owner, Generator Owner, and Distribution Provider shall each keep documentation of Unresolved Maintenance Issues identified by the entity since the last audit, including all that were resolved since the last audit.

1.3. Compliance Monitoring and Assessment Processes:

Compliance Audits

Self-Certifications

Spot Checking

Compliance Investigations

Self-Reporting

Complaints

1.4. Additional Compliance Information

None

Table of Compliance Elements

Requirement Number	Lower VSL	Moderate VSL	High VSL	Severe VSL
R1	The entity's PSMP failed to specify whether one Component Type is being addressed by time-based or performance-based maintenance, or a combination of both (Part 1.1).	The entity's PSMP failed to specify whether two Component Types are being addressed by time-based or performance-based maintenance, or a combination of both (Part 1.1).	The entity's PSMP failed to specify whether three Component Types are being addressed by time-based or performance-based maintenance, or a combination of both. (Part 1.1). OR The entity's PSMP failed to include the applicable monitoring attributes applied to each Component Type consistent with the maintenance intervals specified in Tables 1-1 through 1-5, Table 2, Table 3, Tables 4-1 through 4-3, and Table 5 where monitoring is used to extend the maintenance intervals beyond those specified for unmonitored Components (Part 1.2).	The entity failed to establish a PSMP. OR The entity's PSMP failed to specify whether four or more Component Types are being addressed by time-based or performance-based maintenance, or a combination of both (Part 1.1). OR The entity's PSMP failed to include applicable station batteries in a time-based program (Part 1.1).
R2	The entity uses performance-based maintenance intervals in its PSMP but failed to reduce Countable Events to no more than 4% within three years.	NA	The entity uses performance-based maintenance intervals in its PSMP but failed to reduce Countable Events to no more than 4% within four years.	The entity uses performance-based maintenance intervals in its PSMP but: 1) Failed to establish the technical justification described within Requirement R2 for the initial use of the performance-based PSMP OR 2) Failed to reduce Countable Events to no more than 4% within five years OR

Requirement Number	Lower VSL	Moderate VSL	High VSL	Severe VSL
				3) Maintained a Segment with less than 60 Components OR 4) Failed to: <ul style="list-style-type: none"> • Annually update the list of Components, OR • Annually perform maintenance on the greater of 5% of the Segment population or 3 Components, OR • Annually analyze the program activities and results for each Segment.
R3	For Components included within a time-based maintenance program, the entity failed to maintain 5% or less of the total Components included within a specific Component Type in accordance with the minimum maintenance activities and maximum maintenance intervals prescribed within Tables 1-1 through 1-5, Table 2, Table 3, Tables 4-1 through 4-3, and Table 5.	For Components included within a time-based maintenance program, the entity failed to maintain more than 5% but 10% or less of the total Components included within a specific Component Type in accordance with the minimum maintenance activities and maximum maintenance intervals prescribed within Tables 1-1 through 1-5, Table 2, Table 3, Tables 4-1 through 4-3, and Table 5.	For Components included within a time-based maintenance program, the entity failed to maintain more than 10% but 15% or less of the total Components included within a specific Component Type in accordance with the minimum maintenance activities and maximum maintenance intervals prescribed within Tables 1-1 through 1-5, Table 2, Table 3, Tables 4-1 through 4-3, and Table 5.	For Components included within a time-based maintenance program, the entity failed to maintain more than 15% of the total Components included within a specific Component Type in accordance with the minimum maintenance activities and maximum maintenance intervals prescribed within Tables 1-1 through 1-5, Table 2, Table 3, Tables 4-1 through 4-3, and Table 5.

Requirement Number	Lower VSL	Moderate VSL	High VSL	Severe VSL
R4	For Components included within a performance-based maintenance program, the entity failed to maintain 5% or less of the annual scheduled maintenance for a specific Component Type in accordance with their performance-based PSMP.	For Components included within a performance-based maintenance program, the entity failed to maintain more than 5% but 10% or less of the annual scheduled maintenance for a specific Component Type in accordance with their performance-based PSMP.	For Components included within a performance-based maintenance program, the entity failed to maintain more than 10% but 15% or less of the annual scheduled maintenance for a specific Component Type in accordance with their performance-based PSMP.	For Components included within a performance-based maintenance program, the entity failed to maintain more than 15% of the annual scheduled maintenance for a specific Component Type in accordance with their performance-based PSMP.
R5	The entity failed to undertake efforts to correct 5 or fewer identified Unresolved Maintenance Issues.	The entity failed to undertake efforts to correct greater than 5 but less than or equal to 10 identified Unresolved Maintenance Issues.	The entity failed to undertake efforts to correct greater than 10 but less than or equal to 15 identified Unresolved Maintenance Issues.	The entity failed to undertake efforts to correct greater than 15 identified Unresolved Maintenance Issues.

D. Regional Variances

None.

E. Interpretations

None.

Supplemental Reference Documents

The following documents present a detailed discussion about determination of maintenance intervals and other useful information regarding establishment of a maintenance program.

1. *Supplementary Reference and FAQ - PRC-005-6 Protection System Maintenance*, Protection System Maintenance and Testing Standard Drafting Team (April 2015)
2. *Considerations for Maintenance and Testing of Auto-reclosing Schemes*, NERC System Analysis and Modeling Subcommittee, and NERC System Protection and Control Subcommittee (November 2012)
3. *Sudden Pressure Relays and Other Devices that Respond to Non-Electrical Quantities – SPCS Input for Standard Development in Response to FERC Order No. 758*, NERC System Protection and Control Subcommittee (December 2013)
4. *Sudden Pressure Relays and Other Devices that Respond to Non-Electrical Quantities – Supplemental Information to Support Project 2007-17.3: Protection System Maintenance and Testing* (October 31, 2014)

Version History

Version	Date	Action	Change Tracking
0	February 8, 2005	Adopted by NERC Board of Trustees	New.
1	February 7, 2006	Adopted by NERC Board of Trustees	<ol style="list-style-type: none"> 1. Changed incorrect use of certain hyphens (-) to “en dash” (–) and “em dash (—).” 2. Added “periods” to items where appropriate. Changed “Timeframe” to “Time Frame” in item D, 1.2.
1a	February 17, 2011	Adopted by NERC Board of Trustees	Added Appendix 1 - Interpretation regarding applicability of standard to protection of radially connected transformers developed in Project 2009-17.

Version	Date	Action	Change Tracking
1b	November 5, 2009	Adopted by NERC Board of Trustees	Interpretation of R1, R1.1, and R1.2 developed by Project 2009-10.
1b	February 3, 2012	FERC Order approving revised definition of “Protection System”	Per footnote 8 of FERC’s order, the definition of “Protection System” supersedes interpretation “b” of PRC-005-1b upon the effective date of the modified definition (i.e., April 1, 2013). <i>See N. Amer. Elec. Reliability Corp., 138 FERC ¶ 61,095 (February 3, 2012).</i>
1.1b	May 9, 2012	Adopted by NERC Board of Trustees	Errata change developed by Project 2010-07, clarified inclusion of generator interconnection Facility in Generator Owner’s responsibility.
2	November 7, 2012	Adopted by NERC Board of Trustees	Project 2007-17 - Complete revision, absorbing maintenance requirements from PRC-005-1.1b, PRC-008-0, PRC-011-0, PRC-017-0.
2	October 17, 2013	Approved by NERC Standards Committee	Errata Change: The Standards Committee approved an errata change to the implementation plan for PRC-005-2 to add the phrase “or as otherwise made effective pursuant to the laws applicable to such ERO governmental authorities;” to the second sentence under the “Retirement of Existing Standards” section. (no change to standard version number)
2	March 7, 2014	Adopted by NERC Board of Trustees	Modified R1 VSL in response to FERC directive (no change to standard version number).
2(i)	November 13, 2014	Adopted by NERC Board of Trustees	Applicability section revised by Project 2014-01 to clarify application of Requirements to BES dispersed power producing resources.

Version	Date	Action	Change Tracking
2(ii)	November 13, 2014	Adopted by NERC Board of Trustees	Replaced references to Special Protection System and SPS with Remedial Action Scheme and RAS.
3	November 7, 2013	Adopted by the NERC Board of Trustees	Revised to address the FERC directive in Order No. 758 to include Automatic Reclosing in maintenance programs.
3	February 12, 2014	Approved by NERC Standards Committee	Errata Change: The Standards Committee approved errata changes to correct capitalization of certain defined terms within the definitions of “Unresolved Maintenance Issue” and “Protection System Maintenance Program”. The changes will be reflected in the definitions section of PRC-005-3 for “Unresolved Maintenance Issue” and in the NERC Glossary of Terms for “Protection System Maintenance Program”. (no change to standard version number)
3	March 7, 2014	Adopted by NERC Board of Trustees	Modified R1 VSL in response to FERC directive (no change to standard version number).
3(i)	November 13, 2014	Adopted by NERC Board of Trustees	Applicability section revised by Project 2014-01 to clarify application of Requirements to BES dispersed power producing resources.
3(ii)	November 13, 2014	Adopted by NERC Board of Trustees	Replaced references to Special Protection System and SPS with Remedial Action Scheme and RAS.
4	November 13, 2014	Adopted by NERC Board of Trustees	Added Sudden Pressure Relaying in response to FERC Order No. 758.

Version	Date	Action	Change Tracking
5	TBD		Applicability section revised by Project 2014-01 to clarify application of Requirements to BES dispersed power producing resources.
6	TBD		Revised to add supervisory relays to Automatic Reclosing in accordance with the directives in FERC Order 803.

Table 1-1 Component Type - Protective Relay Excluding distributed UFLS and distributed UVLS (see Table 3)		
Component Attributes	Maximum Maintenance Interval ³	Maintenance Activities
Any unmonitored protective relay not having all the monitoring attributes of a category below.	6 Calendar Years	For all unmonitored relays: <ul style="list-style-type: none"> • Verify that settings are as specified For non-microprocessor relays: <ul style="list-style-type: none"> • Test and, if necessary calibrate For microprocessor relays: <ul style="list-style-type: none"> • Verify operation of the relay inputs and outputs that are essential to proper functioning of the Protection System. • Verify acceptable measurement of power system input values.
Monitored microprocessor protective relay with the following: <ul style="list-style-type: none"> • Internal self-diagnosis and alarming (see Table 2). • Voltage and/or current waveform sampling three or more times per power cycle, and conversion of samples to numeric values for measurement calculations by microprocessor electronics. • Alarming for power supply failure (see Table 2). 	12 Calendar Years	Verify: <ul style="list-style-type: none"> • Settings are as specified. • Operation of the relay inputs and outputs that are essential to proper functioning of the Protection System. • Acceptable measurement of power system input values.

³ For the tables in this standard, a calendar year starts on the first day of a new year (January 1) after a maintenance activity has been completed. For the tables in this standard, a calendar month starts on the first day of the first month after a maintenance activity has been completed.

Table 1-1 Component Type - Protective Relay Excluding distributed UFLS and distributed UVLS (see Table 3)		
Component Attributes	Maximum Maintenance Interval ³	Maintenance Activities
Monitored microprocessor protective relay with preceding row attributes and the following: <ul style="list-style-type: none"> • Ac measurements are continuously verified by comparison to an independent AC measurement source, with alarming for excessive error (See Table 2). • Some or all binary or status inputs and control outputs are monitored by a process that continuously demonstrates ability to perform as designed, with alarming for failure (See Table 2). • Alarming for change of settings (See Table 2). 	12 Calendar Years	Verify only the unmonitored relay inputs and outputs that are essential to proper functioning of the Protection System.

Table 1-2 Component Type - Communications Systems Excluding distributed UFLS and distributed UVLS (see Table 3)		
Component Attributes	Maximum Maintenance Interval	Maintenance Activities
Any unmonitored communications system necessary for correct operation of protective functions, and not having all the monitoring attributes of a category below.	4 Calendar Months	Verify that the communications system is functional.
	6 Calendar Years	Verify that the communications system meets performance criteria pertinent to the communications technology applied (e.g. signal level, reflected power, or data error rate). Verify operation of communications system inputs and outputs that are essential to proper functioning of the Protection System.
Any communications system with continuous monitoring or periodic automated testing for the presence of the channel function, and alarming for loss of function (See Table 2).	12 Calendar Years	Verify that the communications system meets performance criteria pertinent to the communications technology applied (e.g. signal level, reflected power, or data error rate). Verify operation of communications system inputs and outputs that are essential to proper functioning of the Protection System.
Any communications system with all of the following: <ul style="list-style-type: none"> • Continuous monitoring or periodic automated testing for the performance of the channel using criteria pertinent to the communications technology applied (e.g. signal level, reflected power, or data error rate, and alarming for excessive performance degradation). (See Table 2) • Some or all binary or status inputs and control outputs are monitored by a process that continuously demonstrates ability to perform as designed, with alarming for failure (See Table 2). 	12 Calendar Years	Verify only the unmonitored communications system inputs and outputs that are essential to proper functioning of the Protection System

Table 1-3 Component Type - Voltage and Current Sensing Devices Providing Inputs to Protective Relays Excluding distributed UFLS and distributed UVLS (see Table 3)		
Component Attributes	Maximum Maintenance Interval	Maintenance Activities
Any voltage and current sensing devices not having monitoring attributes of the category below.	12 Calendar Years	Verify that current and voltage signal values are provided to the protective relays.
Voltage and Current Sensing devices connected to microprocessor relays with AC measurements that are continuously verified by comparison of sensing input value, as measured by the microprocessor relay, to an independent AC measurement source, with alarming for unacceptable error or failure (see Table 2).	No periodic maintenance specified	None.

Table 1-4(a) Component Type – Protection System Station DC Supply Using Vented Lead-Acid (VLA) Batteries Excluding distributed UFLS and distributed UVLS (see Table 3)		
Protection System Station DC supply used only for non-BES interrupting devices for RAS, non-distributed UFLS systems, or non-distributed UVLS systems is excluded (see Table 1-4(e)).		
Component Attributes	Maximum Maintenance Interval	Maintenance Activities
Protection System Station DC supply using Vented Lead-Acid (VLA) batteries not having monitoring attributes of Table 1-4(f).	4 Calendar Months	Verify: <ul style="list-style-type: none"> • Station DC supply voltage Inspect: <ul style="list-style-type: none"> • Electrolyte level • For unintentional grounds
	18 Calendar Months	Verify: <ul style="list-style-type: none"> • Float voltage of battery charger • Battery continuity • Battery terminal connection resistance • Battery intercell or unit-to-unit connection resistance Inspect: <ul style="list-style-type: none"> • Cell condition of all individual battery cells where cells are visible – or measure battery cell/unit internal ohmic values where the cells are not visible • Physical condition of battery rack

<p style="text-align: center;">Table 1-4(a) Component Type – Protection System Station DC Supply Using Vented Lead-Acid (VLA) Batteries Excluding distributed UFLS and distributed UVLS (see Table 3)</p> <p style="text-align: center;">Protection System Station DC supply used only for non-BES interrupting devices for RAS, non-distributed UFLS systems, or non-distributed UVLS systems is excluded (see Table 1-4(e)).</p>		
Component Attributes	Maximum Maintenance Interval	Maintenance Activities
	18 Calendar Months -or- 6 Calendar Years	Verify that the station battery can perform as manufactured by evaluating cell/unit measurements indicative of battery performance (e.g. internal ohmic values or float current) against the station battery baseline. -or- Verify that the station battery can perform as manufactured by conducting a performance or modified performance capacity test of the entire battery bank.

Table 1-4(b) Component Type – Protection System Station DC Supply Using Valve-Regulated Lead-Acid (VRLA) Batteries Excluding distributed UFLS and distributed UVLS (see Table 3)		
Protection System Station DC supply used only for non-BES interrupting devices for RAS, non-distributed UFLS systems, or non-distributed UVLS systems is excluded (see Table 1-4(e)).		
Component Attributes	Maximum Maintenance Interval	Maintenance Activities
Protection System Station DC supply with Valve Regulated Lead-Acid (VRLA) batteries not having monitoring attributes of Table 1-4(f).	4 Calendar Months	Verify: <ul style="list-style-type: none"> • Station DC supply voltage Inspect: <ul style="list-style-type: none"> • For unintentional grounds
	6 Calendar Months	Inspect: <ul style="list-style-type: none"> • Condition of all individual units by measuring battery cell/unit internal ohmic values.
	18 Calendar Months	Verify: <ul style="list-style-type: none"> • Float voltage of battery charger • Battery continuity • Battery terminal connection resistance • Battery intercell or unit-to-unit connection resistance Inspect: <ul style="list-style-type: none"> • Physical condition of battery rack

<p style="text-align: center;">Table 1-4(b) Component Type – Protection System Station DC Supply Using Valve-Regulated Lead-Acid (VRLA) Batteries Excluding distributed UFLS and distributed UVLS (see Table 3)</p> <p style="text-align: center;">Protection System Station DC supply used only for non-BES interrupting devices for RAS, non-distributed UFLS systems, or non-distributed UVLS systems is excluded (see Table 1-4(e)).</p>		
Component Attributes	Maximum Maintenance Interval	Maintenance Activities
	6 Calendar Months -or- 3 Calendar Years	Verify that the station battery can perform as manufactured by evaluating cell/unit measurements indicative of battery performance (e.g. internal ohmic values or float current) against the station battery baseline. -or- Verify that the station battery can perform as manufactured by conducting a performance or modified performance capacity test of the entire battery bank.

Table 1-4(c) Component Type – Protection System Station DC Supply Using Nickel-Cadmium (NiCad) Batteries Excluding distributed UFLS and distributed UVLS (see Table 3)		
Protection System Station DC supply used only for non-BES interrupting devices for RAS, non-distributed UFLS system, or non-distributed UVLS systems is excluded (see Table 1-4(e)).		
Component Attributes	Maximum Maintenance Interval	Maintenance Activities
Protection System Station DC supply Nickel-Cadmium (NiCad) batteries not having monitoring attributes of Table 1-4(f).	4 Calendar Months	Verify: <ul style="list-style-type: none"> • Station DC supply voltage Inspect: <ul style="list-style-type: none"> • Electrolyte level • For unintentional grounds
	18 Calendar Months	Verify: <ul style="list-style-type: none"> • Float voltage of battery charger • Battery continuity • Battery terminal connection resistance • Battery intercell or unit-to-unit connection resistance Inspect: <ul style="list-style-type: none"> • Cell condition of all individual battery cells. • Physical condition of battery rack

Table 1-4(c) Component Type – Protection System Station DC Supply Using Nickel-Cadmium (NiCad) Batteries Excluding distributed UFLS and distributed UVLS (see Table 3)		
Protection System Station DC supply used only for non-BES interrupting devices for RAS, non-distributed UFLS system, or non-distributed UVLS systems is excluded (see Table 1-4(e)).		
Component Attributes	Maximum Maintenance Interval	Maintenance Activities
	6 Calendar Years	Verify that the station battery can perform as manufactured by conducting a performance or modified performance capacity test of the entire battery bank.

Table 1-4(d) Component Type – Protection System Station DC Supply Using Non Battery Based Energy Storage Excluding distributed UFLS and distributed UVLS (see Table 3)		
Protection System Station DC supply used only for non-BES interrupting devices for RAS, non-distributed UFLS system, or non-distributed UVLS systems is excluded (see Table 1-4(e)).		
Component Attributes	Maximum Maintenance Interval	Maintenance Activities
Any Protection System station DC supply not using a battery and not having monitoring attributes of Table 1-4(f).	4 Calendar Months	Verify: <ul style="list-style-type: none"> • Station DC supply voltage Inspect: <ul style="list-style-type: none"> • For unintentional grounds
	18 Calendar Months	Inspect: Condition of non-battery based DC supply
	6 Calendar Years	Verify that the DC supply can perform as manufactured when AC power is not present.

Table 1-4(e)		
Component Type – Protection System Station DC Supply for non-BES Interrupting Devices for RAS, non-distributed UFLS, and non-distributed UVLS systems		
Component Attributes	Maximum Maintenance Interval	Maintenance Activities
Any Protection System DC supply used for tripping only non-BES interrupting devices as part of a RAS, non-distributed UFLS, or non-distributed UVLS system and not having monitoring attributes of Table 1-4(f).	When control circuits are verified (See Table 1-5)	Verify Station DC supply voltage.

Table 1-4(f) Exclusions for Protection System Station DC Supply Monitoring Devices and Systems		
Component Attributes	Maximum Maintenance Interval	Maintenance Activities
Any station DC supply with high and low voltage monitoring and alarming of the battery charger voltage to detect charger overvoltage and charger failure (See Table 2).	No periodic maintenance specified	No periodic verification of station DC supply voltage is required.
Any battery based station DC supply with electrolyte level monitoring and alarming in every cell (See Table 2).		No periodic inspection of the electrolyte level for each cell is required.
Any station DC supply with unintentional DC ground monitoring and alarming (See Table 2).		No periodic inspection of unintentional DC grounds is required.
Any station DC supply with charger float voltage monitoring and alarming to ensure correct float voltage is being applied on the station DC supply (See Table 2).		No periodic verification of float voltage of battery charger is required.
Any battery based station DC supply with monitoring and alarming of battery string continuity (See Table 2).		No periodic verification of the battery continuity is required.
Any battery based station DC supply with monitoring and alarming of the intercell and/or terminal connection detail resistance of the entire battery (See Table 2).		No periodic verification of the intercell and terminal connection resistance is required.
Any Valve Regulated Lead-Acid (VRLA) or Vented Lead-Acid (VLA) station battery with internal ohmic value or float current monitoring and alarming, and evaluating present values relative to baseline internal ohmic values for every cell/unit (See Table 2).		No periodic evaluation relative to baseline of battery cell/unit measurements indicative of battery performance is required to verify the station battery can perform as manufactured.
Any Valve Regulated Lead-Acid (VRLA) or Vented Lead-Acid (VLA) station battery with monitoring and alarming of each cell/unit internal ohmic value (See Table 2).		No periodic inspection of the condition of all individual units by measuring battery cell/unit internal ohmic values of a station VRLA or Vented Lead-Acid (VLA) battery is required.

<p align="center">Table 1-5</p> <p align="center">Component Type - Control Circuitry Associated With Protective Functions</p> <p align="center">Excluding distributed UFLS and distributed UVLS (see Table 3), Automatic Reclosing (see Table 4), and Sudden Pressure Relaying (see Table 5)</p> <p align="center">Note: Table requirements apply to all Control Circuitry Components of Protection Systems, and RAS except as noted.</p>		
Component Attributes	Maximum Maintenance Interval	Maintenance Activities
Trip coils or actuators of circuit breakers, interrupting devices, or mitigating devices (regardless of any monitoring of the control circuitry).	6 Calendar Years	Verify that each trip coil is able to operate the circuit breaker, interrupting device, or mitigating device.
Electromechanical lockout devices which are directly in a trip path from the protective relay to the interrupting device trip coil (regardless of any monitoring of the control circuitry).	6 Calendar Years	Verify electrical operation of electromechanical lockout devices.
Unmonitored control circuitry associated with RAS. (See Table 4-2(b) for RAS which include Automatic Reclosing.)	12 Calendar Years	Verify all paths of the control circuits essential for proper operation of the RAS.
Unmonitored control circuitry associated with protective functions inclusive of all auxiliary relays.	12 Calendar Years	Verify all paths of the trip circuits inclusive of all auxiliary relays through the trip coil(s) of the circuit breakers or other interrupting devices.
Control circuitry associated with protective functions and/or RAS whose integrity is monitored and alarmed (See Table 2).	No periodic maintenance specified	None.

Table 2 – Alarming Paths and Monitoring In Tables 1-1 through 1-5, Table 3, Tables 4-1 through 4-3, and Table 5 alarm attributes used to justify extended maximum maintenance intervals and/or reduced maintenance activities are subject to the following maintenance requirements		
Component Attributes	Maximum Maintenance Interval	Maintenance Activities
Any alarm path through which alarms in Tables 1-1 through 1-5, Table 3, Tables 4-1 through 4-3, and Table 5 are conveyed from the alarm origin to the location where corrective action can be initiated, and not having all the attributes of the “Alarm Path with monitoring” category below. Alarms are reported within 24 hours of detection to a location where corrective action can be initiated.	12 Calendar Years	Verify that the alarm path conveys alarm signals to a location where corrective action can be initiated.
Alarm Path with monitoring: The location where corrective action is taken receives an alarm within 24 hours for failure of any portion of the alarming path from the alarm origin to the location where corrective action can be initiated.	No periodic maintenance specified	None.

Table 3 Maintenance Activities and Intervals for distributed UFLS and distributed UVLS Systems		
Component Attributes	Maximum Maintenance Interval	Maintenance Activities
Any unmonitored protective relay not having all the monitoring attributes of a category below.	6 Calendar Years	Verify that settings are as specified. For non-microprocessor relays: <ul style="list-style-type: none"> • Test and, if necessary calibrate. For microprocessor relays: <ul style="list-style-type: none"> • Verify operation of the relay inputs and outputs that are essential to proper functioning of the Protection System. • Verify acceptable measurement of power system input values.
Monitored microprocessor protective relay with the following: <ul style="list-style-type: none"> • Internal self-diagnosis and alarming (See Table 2). • Voltage and/or current waveform sampling three or more times per power cycle, and conversion of samples to numeric values for measurement calculations by microprocessor electronics. Alarming for power supply failure (See Table 2).	12 Calendar Years	Verify: <ul style="list-style-type: none"> • Settings are as specified. • Operation of the relay inputs and outputs that are essential to proper functioning of the Protection System. • Acceptable measurement of power system input values.
Monitored microprocessor protective relay with preceding row attributes and the following: <ul style="list-style-type: none"> • Ac measurements are continuously verified by comparison to an independent AC measurement source, with alarming for excessive error (See Table 2). 	12 Calendar Years	Verify only the unmonitored relay inputs and outputs that are essential to proper functioning of the Protection System.

Table 3 Maintenance Activities and Intervals for distributed UFLS and distributed UVLS Systems		
Component Attributes	Maximum Maintenance Interval	Maintenance Activities
<ul style="list-style-type: none"> Some or all binary or status inputs and control outputs are monitored by a process that continuously demonstrates ability to perform as designed, with alarming for failure (See Table 2). Alarming for change of settings (See Table 2).		
Voltage and/or current sensing devices associated with UFLS or UVLS systems.	12 Calendar Years	Verify that current and/or voltage signal values are provided to the protective relays.
Protection System DC supply for tripping non-BES interrupting devices used only for a UFLS or UVLS system.	12 Calendar Years	Verify Protection System DC supply voltage.
Control circuitry between the UFLS or UVLS relays and electromechanical lockout and/or tripping auxiliary devices (excludes non-BES interrupting device trip coils).	12 Calendar Years	Verify the path from the relay to the lockout and/or tripping auxiliary relay (including essential supervisory logic).
Electromechanical lockout and/or tripping auxiliary devices associated only with UFLS or UVLS systems (excludes non-BES interrupting device trip coils).	12 Calendar Years	Verify electrical operation of electromechanical lockout and/or tripping auxiliary devices.
Control circuitry between the electromechanical lockout and/or tripping auxiliary devices and the non-BES interrupting devices in UFLS or UVLS systems, or between UFLS or UVLS relays (with no interposing electromechanical lockout or auxiliary device) and the non-BES interrupting devices (excludes non-BES interrupting device trip coils).	No periodic maintenance specified	None.
Trip coils of non-BES interrupting devices in UFLS or UVLS systems.	No periodic maintenance specified	None.

<p style="text-align: center;">Table 4-1 Maintenance Activities and Intervals for Automatic Reclosing Components Component Type – Reclosing and Supervisory Relay</p>		
<p>Note: In cases where Components of Automatic Reclosing are common to Components listed in Table 1-1 through 1-5, the Components only need to be tested once during a distinct maintenance interval.</p>		
Component Attributes	Maximum Maintenance Interval	Maintenance Activities
<p>Any unmonitored reclosing relay or supervisory relay not having all the monitoring attributes of a category below.</p>	<p>6 Calendar Years</p>	<p>Verify that settings are as specified.</p> <p>For non-microprocessor relays:</p> <ul style="list-style-type: none"> • Test and, if necessary calibrate <p>For microprocessor relays:</p> <ul style="list-style-type: none"> • Verify operation of the relay inputs and outputs that are essential to proper functioning of the Automatic Reclosing. <p>For microprocessor supervisory relays:</p> <ul style="list-style-type: none"> • Verify acceptable measurement of power system input values.
<ul style="list-style-type: none"> • Monitored microprocessor reclosing relay or supervisory relay with the following: Internal self-diagnosis and alarming (See Table 2). • Alarming for power supply failure (See Table 2). <p>For supervisory relay:</p> <ul style="list-style-type: none"> • Voltage waveform sampling three or more times per power cycle, and conversion of samples to numeric values for measurement calculations by microprocessor electronics. 	<p>12 Calendar Years</p>	<p>Verify:</p> <ul style="list-style-type: none"> • Settings are as specified. <p>Operation of the relay inputs and outputs that are essential to proper functioning of the Automatic Reclosing.</p> <p>For supervisory relays:</p> <ul style="list-style-type: none"> • Verify acceptable measurement of power system input values.

Table 4-1 Maintenance Activities and Intervals for Automatic Reclosing Components Component Type – Reclosing and Supervisory Relay		
Note: In cases where Components of Automatic Reclosing are common to Components listed in Table 1-1 through 1-5, the Components only need to be tested once during a distinct maintenance interval.		
Component Attributes	Maximum Maintenance Interval	Maintenance Activities
Monitored microprocessor reclosing relay or supervisory relay with preceding row attributes and the following: <ul style="list-style-type: none"> • Some or all binary or status inputs and control outputs are monitored by a process that continuously demonstrates ability to perform as designed, with alarming for failure (See Table 2). • Alarming for change of settings (See Table 2). For supervisory relay: <ul style="list-style-type: none"> • AC measurements are continuously verified by comparison to an independent AC measurement source, with alarming for excessive error (See Table 2). 	12 Calendar Years	Verify only the unmonitored relay inputs and outputs that are essential to proper functioning of the Automatic Reclosing.

<p style="text-align: center;">Table 4-2(a) Maintenance Activities and Intervals for Automatic Reclosing Components Component Type – Control Circuitry Associated with Reclosing and Supervisory Relays that are NOT an Integral Part of an RAS Note: In cases where Components of Sudden Pressure Relaying are common to Components listed in Table 1-5, the Components only need to be tested once during a distinct maintenance interval.</p>		
Component Attributes	Maximum Maintenance Interval	Maintenance Activities
Unmonitored Control circuitry associated with Automatic Reclosing that is not an integral part of an RAS.	12 Calendar Years	Verify that Automatic Reclosing, upon initiation, does not issue a premature closing command to the close circuitry.
Control circuitry associated with Automatic Reclosing that is not part of an RAS and is monitored and alarmed for conditions that would result in a premature closing command. (See Table 2)	No periodic maintenance specified	None.

<p align="center">Table 4-2(b) Maintenance Activities and Intervals for Automatic Reclosing Components Component Type – Control Circuitry Associated with Reclosing and Supervisory Relays that ARE an Integral Part of an RAS Note: In cases where Components of Sudden Pressure Relaying are common to Components listed in Table 1-5, the Components only need to be tested once during a distinct maintenance interval.</p>		
Component Attributes	Maximum Maintenance Interval	Maintenance Activities
Close coils or actuators of circuit breakers or similar devices that are used in conjunction with Automatic Reclosing as part of an RAS (regardless of any monitoring of the control circuitry).	6 Calendar Years	Verify that each close coil or actuator is able to operate the circuit breaker or mitigating device.
Unmonitored close control circuitry associated with Automatic Reclosing used as an integral part of an RAS.	12 Calendar Years	Verify all paths of the control circuits associated with Automatic Reclosing that are essential for proper operation of the RAS.
Control circuitry associated with Automatic Reclosing that is an integral part of an RAS whose integrity is monitored and alarmed. (See Table 2)	No periodic maintenance specified	None.

<p align="center">Table 4-3</p> <p align="center">Maintenance Activities and Intervals for Automatic Reclosing Components</p> <p align="center">Component Type – Voltage Sensing Devices Associated with Supervisory Relays</p> <p align="center">Note: In cases where Components of Sudden Pressure Relaying are common to Components listed in Table 1-5, the Components only need to be tested once during a distinct maintenance interval.</p>		
Component Attributes	Maximum Maintenance Interval	Maintenance Activities
Any voltage sensing devices not having monitoring attributes of the category below.	12 Calendar Years	Verify that voltage signal values are provided to the supervisory relays.
Voltage sensing devices that are connected to microprocessor supervisory relays with AC measurements that are continuously verified by comparison of sensing input value, as measured by the microprocessor relay, to an independent AC measurement source, with alarming for unacceptable error or failure. (See Table 2)	No periodic maintenance specified	None.

<p style="text-align: center;">Table 5 Maintenance Activities and Intervals for Sudden Pressure Relaying</p>		
<p style="text-align: center;">Note: In cases where Components of Sudden Pressure Relaying are common to Components listed in Table 1-5, the Components only need to be tested once during a distinct maintenance interval.</p>		
Component Attributes	Maximum Maintenance Interval	Maintenance Activities
Any fault pressure relay.	6 Calendar Years	Verify the pressure or flow sensing mechanism is operable.
Electromechanical lockout devices which are directly in a trip path from the fault pressure relay to the interrupting device trip coil (regardless of any monitoring of the control circuitry).	6 Calendar Years	Verify electrical operation of electromechanical lockout devices.
Unmonitored control circuitry associated with Sudden Pressure Relaying.	12 Calendar Years	Verify all paths of the trip circuits inclusive of all auxiliary relays through the trip coil(s) of the circuit breakers or other interrupting devices.
Control circuitry associated with Sudden Pressure Relaying whose integrity is monitored and alarmed (See Table 2).	No periodic maintenance specified	None.

PRC-005 — Attachment A

Criteria for a Performance-Based Protection System Maintenance Program

Purpose: To establish a technical basis for initial and continued use of a performance-based Protection System Maintenance Program (PSMP).

To establish the technical justification for the initial use of a performance-based PSMP:

1. Develop a list with a description of Components included in each designated Segment, with a minimum Segment population of 60 Components.
2. Maintain the Components in each Segment according to the time-based maximum allowable intervals established in Tables 1-1 through 1-5, Table 3, Tables 4-1 through 4-3, and Table 5 until results of maintenance activities for the Segment are available for a minimum of 30 individual Components of the Segment.
3. Document the maintenance program activities and results for each Segment, including maintenance dates and Countable Events for each included Component.
4. Analyze the maintenance program activities and results for each Segment to determine the overall performance of the Segment and develop maintenance intervals.
5. Determine the maximum allowable maintenance interval for each Segment such that the Segment experiences Countable Events on no more than 4% of the Components within the Segment, for the greater of either the last 30 Components maintained or all Components maintained in the previous year.

To maintain the technical justification for the ongoing use of a performance-based PSMP:

1. At least annually, update the list of Components and Segments and/or description if any changes occur within the Segment.
2. Perform maintenance on the greater of 5% of the Components (addressed in the performance based PSMP) in each Segment or 3 individual Components within the Segment in each year.
3. For the prior year, analyze the maintenance program activities and results for each Segment to determine the overall performance of the Segment.
4. Using the prior year's data, determine the maximum allowable maintenance interval for each Segment such that the Segment experiences Countable Events on no more than 4% of the Components within the Segment, for the greater of either the last 30 Components maintained or all Components maintained in the previous year.

If the Components in a Segment maintained through a performance-based PSMP experience 4% or more Countable Events, develop, document, and implement an action plan to reduce the Countable Events to less than 4% of the Segment population within 3 years.

Rationale:

During development of this standard, text boxes were embedded within the standard to explain the rationale for various parts of the standard. Upon BOT approval, the text from the rationale text boxes was moved to this section.

Standard Development Timeline

This section is maintained by the drafting team during the development of the standard and will be removed when the standard becomes effective.

Development Steps Completed

1. SAR posted for comment March 12 – April 10, 2015.
2. Revised SAR reposted with revisions for comment June 11 – July 10, 2015

Description of Current Draft

This version of PRC-005 was posted for a 45-day concurrent comment and ballot period to address directives from [FERC Order No. 803](#), addressing Automatic Reclosing. Specifically, supervisory relays, associated voltage sensing devices, and associated control circuitry were added.

Anticipated Actions	Anticipated Dates
45-day Formal Comment Period with Concurrent Ballot	July 2015 – September 2015
Final ballot	October 2015
BOT adoption	November 2015

Definitions of Terms Used in Standard

This section includes all newly defined or revised terms used in the proposed standard. Terms already defined in the Reliability Standards Glossary of Terms (Glossary) are not repeated here. New or revised definitions listed below become approved when the proposed standard is approved. When the standard becomes effective, this defined term will be removed from the individual standard and added to the Glossary.

[See Section 6 of the Standard](#)

A. Introduction

1. **Title:** Protection System, Automatic Reclosing, and Sudden Pressure Relaying Maintenance
2. **Number:** PRC-005-~~65~~
3. **Purpose:** To document and implement programs for the maintenance of all Protection Systems, Automatic Reclosing, and Sudden Pressure Relaying affecting the reliability of the Bulk Electric System (BES) so that they are kept in working order.
4. **Applicability:**
 - 4.1. **Functional Entities:**
 - 4.1.1 Transmission Owner
 - 4.1.2 Generator Owner
 - 4.1.3 Distribution Provider
 - 4.2. **Facilities:**
 - 4.2.1 Protection Systems and Sudden Pressure Relaying that are installed for the purpose of detecting Faults on BES Elements (lines, buses, transformers, etc.)
 - 4.2.2 Protection Systems used for underfrequency load-shedding systems installed per ERO underfrequency load-shedding requirements.
 - 4.2.3 Protection Systems used for undervoltage load-shedding systems installed to prevent system voltage collapse or voltage instability for BES reliability.
 - 4.2.4 Protection Systems installed as a Remedial Action Scheme (RAS) for BES reliability.
 - 4.2.5 Protection Systems and Sudden Pressure Relaying for generator Facilities that are part of the BES, except for generators identified through Inclusion I4 of the BES definition, including:
 - 4.2.5.1 Protection Systems that act to trip the generator either directly or via lockout or auxiliary tripping relays.
 - 4.2.5.2 Protection Systems and Sudden Pressure Relaying for generator step-up transformers for generators that are part of the BES.
 - 4.2.5.3 Protection Systems and Sudden Pressure Relaying for station service or excitation transformers connected to the generator bus of generators which are part of the BES, that act to trip the generator either directly or via lockout or tripping auxiliary relays.

4.2.6 Protection Systems and Sudden Pressure Relaying for the following BES generator Facilities for dispersed power producing resources identified through Inclusion I4 of the BES definition:

4.2.6.1 Protection Systems and Sudden Pressure Relaying for Facilities used in aggregating dispersed BES generation from the point where those resources aggregate to greater than 75 MVA to a common point of connection at 100kV or above.

4.2.7 Automatic Reclosing¹, including:

4.2.7.1 Automatic Reclosing applied on the terminals of Elements connected to the BES bus located at generating plant substations where the total installed gross generating plant capacity is greater than the gross capacity of the largest BES generating unit within the Balancing Authority Area or, if a member of a Reserve Sharing Group, the largest generating unit within the Reserve Sharing Group.²

4.2.7.2 Automatic Reclosing applied on the terminals of all BES Elements at substations one bus away from generating plants specified in Section 4.2.7.1 when the substation is less than 10 circuit-miles from the generating plant substation.

4.2.7.3 Automatic Reclosing applied as an integral part of an RAS specified in Section 4.2.4.

5. Effective Date: See the Implementation Plan for this standard.

6. Definitions Used in this Standard:

¹ Automatic Reclosing addressed in Section 4.2.7.1 and 4.2.7.2 may be excluded if the equipment owner can demonstrate that a close-in three-phase fault present for twice the normal clearing time (capturing a minimum trip-close-trip time delay) does not result in a total loss of gross generation in the Interconnection exceeding the gross capacity of the largest relevant BES generating unit where the Automatic Reclosing is applied.

² The largest BES generating unit within the Balancing Authority Area or the largest generating unit within the Reserve Sharing Group, as applicable, is subject to change. As a result of such a change, the Automatic Reclosing Components subject to the standard could change effective on the date of such change.

Automatic Reclosing – Includes the following Components:

- Reclosing relay
- Supervisory relay(s) or function(s) – relay(s) or function(s) that perform voltage and/or sync check functions that enable or disable operation of the reclosing relay
- Voltage sensing devices associated with the supervisory relay(s)
- Control circuitry associated with the reclosing relay or supervisory relay(s)

Rationale for revisions to Automatic Reclosing: To address directives from FERC Order No. 803 addressing Automatic Reclosing, the definition for Automatic Reclosing was revised to add supervisory relays, the associated voltage sensing devices, and the associated control circuitry.

Sudden Pressure Relaying – A system that trips an interrupting device(s) to isolate the equipment it is monitoring and includes the following Components:

- Fault pressure relay – a mechanical relay or device that detects rapid changes in gas pressure, oil pressure, or oil flow that are indicative of Faults within liquid-filled, wire-wound equipment
- Control circuitry associated with a fault pressure relay

Unresolved Maintenance Issue – A deficiency identified during a maintenance activity that causes the Component to not meet the intended performance, cannot be corrected during the maintenance interval, and requires follow-up corrective action.

Segment – Components of a consistent design standard, or a particular model or type from a single manufacturer that typically share other common elements. Consistent performance is expected across the entire population of a Segment. A Segment must contain at least sixty (60) individual Components.

Component Type –

- Any one of the five specific elements of a Protection System.
- Any one of the ~~two~~ four specific elements of Automatic Reclosing.
- Any one of the two specific elements of Sudden Pressure Relaying.

Rationale for revisions to Component Type: With the revision of the definition of Automatic Reclosing, there are four specific elements of this definition, rather than two as stated in the prior version.

Component – Any individual discrete piece of equipment included in a Protection System, Automatic Reclosing, or Sudden Pressure Relaying.

Countable Event – A failure of a Component requiring repair or replacement, any condition discovered during the maintenance activities in Tables 1-1 through 1-5, Table

3, Tables 4-1 through 4-~~32~~, and Table 5, which requires corrective action or a Protection System Misoperation attributed to hardware failure or calibration failure. Misoperations due to product design errors, software errors, relay settings different from specified settings, Protection System Component, Automatic Reclosing, or Sudden Pressure Relaying configuration or application errors are not included in Countable Events.

B. Requirements and Measures

- R1.** Each Transmission Owner, Generator Owner, and Distribution Provider shall establish a Protection System Maintenance Program (PSMP) for its Protection Systems, Automatic Reclosing, and Sudden Pressure Relaying identified in Section 4.2, Facilities. *[Violation Risk Factor: Medium] [Time Horizon: Operations Planning]*

The PSMP shall:

- 1.1.** Identify which maintenance method (time-based, performance-based per PRC-005 Attachment A, or a combination) is used to address each Protection System, Automatic Reclosing, and Sudden Pressure Relaying Component Type. All batteries associated with the station ~~dc-DC~~ supply Component Type of a Protection System shall be included in a time-based program as described in Table 1-4 and Table 3.
- 1.2.** Include the applicable monitored Component attributes applied to each Protection System, Automatic Reclosing, and Sudden Pressure Relaying Component Type consistent with the maintenance intervals specified in Tables 1-1 through 1-5, Table 2, Table 3, Table 4-1 through 4-~~32~~, and Table 5 where monitoring is used to extend the maintenance intervals beyond those specified for unmonitored Protection System, Automatic Reclosing, and Sudden Pressure Relaying Components.
- M1.** Each Transmission Owner, Generator Owner and Distribution Provider shall have a documented ~~PSMP~~Protection System Maintenance Program in accordance with Requirement R1.

For each Protection System, Automatic Reclosing, and Sudden Pressure Relaying Component Type, the documentation shall include the type of maintenance method applied (time-based, performance-based, or a combination of these maintenance methods), and shall include all batteries associated with the station ~~dc-DC~~ supply Component Types in a time-based program as described in Table 1-4 and Table 3. (Part 1.1)

For Component Types that use monitoring to extend the maintenance intervals, the responsible entity(s) shall have evidence for each Protection System, Automatic Reclosing, and Sudden Pressure Relaying Component Type (such as manufacturer's specifications or engineering drawings) of the appropriate monitored Component attributes as specified in Tables 1-1 through 1-5, Table 2, Table 3, Table 4-1 through 4-~~32~~, and Table 5. (Part 1.2)

- R2.** Each Transmission Owner, Generator Owner, and Distribution Provider that uses performance-based maintenance intervals in its PSMP shall follow the procedure established in PRC-005 Attachment A to establish and maintain its performance-based intervals. *[Violation Risk Factor: Medium] [Time Horizon: Operations Planning]*
- M2.** Each Transmission Owner, Generator Owner, and Distribution Provider that uses performance-based maintenance intervals shall have evidence that its current performance-based maintenance program(s) is in accordance with Requirement R2, which may include, but is not limited to, Component lists, dated maintenance records, and dated analysis records and results.
- R3.** Each Transmission Owner, Generator Owner, and Distribution Provider that utilizes time-based maintenance program(s) shall maintain its Protection System, Automatic Reclosing, and Sudden Pressure Relaying Components that are included within the time-based maintenance program in accordance with the minimum maintenance activities and maximum maintenance intervals prescribed within Tables 1-1 through 1-5, Table 2, Table 3, Table 4-1 through 4-~~3~~², and Table 5. *[Violation Risk Factor: High] [Time Horizon: Operations Planning]*
- M3.** Each Transmission Owner, Generator Owner, and Distribution Provider that utilizes time-based maintenance program(s) shall have evidence that it has maintained its Protection System, Automatic Reclosing, and Sudden Pressure Relaying Components included within its time-based program in accordance with Requirement R3. The evidence may include, but is not limited to, dated maintenance records, dated maintenance summaries, dated check-off lists, dated inspection records, or dated work orders.
- R4.** Each Transmission Owner, Generator Owner, and Distribution Provider that utilizes performance-based maintenance program(s) in accordance with Requirement R2 shall implement and follow its PSMP for its Protection System, Automatic Reclosing, and Sudden Pressure Relaying Components that are included within the performance-based program(s). *[Violation Risk Factor: High] [Time Horizon: Operations Planning]*
- M4.** Each Transmission Owner, Generator Owner, and Distribution Provider that utilizes performance-based maintenance intervals in accordance with Requirement R2 shall have evidence that it has implemented the ~~PSMP~~**Protection System Maintenance Program** for the Protection System, Automatic Reclosing, and Sudden Pressure Relaying Components included in its performance-based program in accordance with Requirement R4. The evidence may include, but is not limited to, dated maintenance records, dated maintenance summaries, dated check-off lists, dated inspection records, or dated work orders.
- R5.** Each Transmission Owner, Generator Owner, and Distribution Provider shall demonstrate efforts to correct identified Unresolved Maintenance Issues. *[Violation Risk Factor: Medium] [Time Horizon: Operations Planning]*
- M5.** Each Transmission Owner, Generator Owner, and Distribution Provider shall have evidence that it has undertaken efforts to correct identified Unresolved Maintenance

Issues in accordance with Requirement R5. The evidence may include, but is not limited to, work orders, replacement Component orders, invoices, project schedules with completed milestones, return material authorizations (RMAs) or purchase orders.

C. Compliance

1. Compliance Monitoring Process

1.1. Compliance Enforcement Authority

As defined in the NERC Rules of Procedure, “Compliance Enforcement Authority” means NERC or the Regional Entity in their respective roles of monitoring and enforcing compliance with the NERC Reliability Standards.

1.2. Evidence Retention

The following evidence retention periods identify the period of time an entity is required to retain specific evidence to demonstrate compliance. For instances where the evidence retention period specified below is shorter than the time since the last audit, the Compliance Enforcement Authority may ask an entity to provide other evidence to show that it was compliant for the full time period since the last audit.

The Transmission Owner, Generator Owner, and Distribution Provider shall each keep data or evidence to show compliance as identified below unless directed by its Compliance Enforcement Authority to retain specific evidence for a longer period of time as part of an investigation.

For Requirement R1, the Transmission Owner, Generator Owner, and Distribution Provider shall each keep its current dated ~~PSMP~~Protection System Maintenance Program, as well as any superseded versions since the preceding compliance audit, including the documentation that specifies the type of maintenance program applied for each Protection System, Automatic Reclosing, or Sudden Pressure Relaying Component Type.

For Requirement R2, Requirement R3, and Requirement R4, in cases where the interval of the maintenance activity is longer than the audit cycle, the Transmission Owner, Generator Owner, and Distribution Provider shall each keep documentation of the most recent performance of that maintenance activity for the Protection System, Automatic Reclosing, or Sudden Pressure Relaying Component. In cases where the interval of the maintenance activity is shorter than the audit cycle, documentation of all performances (in accordance with the tables) of that maintenance activity for the Protection System, Automatic Reclosing, or Sudden Pressure Relaying Component since the previous scheduled audit date shall be retained.

For Requirement R5 the Transmission Owner, Generator Owner, and Distribution Provider shall each keep documentation of Unresolved Maintenance Issues identified by the entity since the last audit, including all that were resolved since the last audit.

~~The Compliance Enforcement Authority shall keep the last audit records and all requested and submitted subsequent audit records.~~

1.3. Compliance Monitoring and Assessment Processes:

Compliance Audits

Self-Certifications

Spot Checking

Compliance ~~Violation~~ Investigations

Self-Reporting

Complaints

1.4. Additional Compliance Information

None

Table of Compliance Elements

Requirement Number	Lower VSL	Moderate VSL	High VSL	Severe VSL
R1	The entity's PSMP failed to specify whether one Component Type is being addressed by time-based or performance-based maintenance, or a combination of both (Part 1.1).	The entity's PSMP failed to specify whether two Component Types are being addressed by time-based or performance-based maintenance, or a combination of both (Part 1.1).	<p>The entity's PSMP failed to specify whether three Component Types are being addressed by time-based or performance-based maintenance, or a combination of both. (Part 1.1).</p> <p>OR</p> <p>The entity's PSMP failed to include the applicable monitoring attributes applied to each Component Type consistent with the maintenance intervals specified in Tables 1-1 through 1-5, Table 2, Table 3, Tables 4-1 through 4-32, and Table 5 where monitoring is used to extend the maintenance intervals beyond those specified for unmonitored Components (Part 1.2).</p>	<p>The entity failed to establish a PSMP.</p> <p>OR</p> <p>The entity's PSMP failed to specify whether four or more Component Types are being addressed by time-based or performance-based maintenance, or a combination of both (Part 1.1).</p> <p>OR</p> <p>The entity's PSMP failed to include applicable station batteries in a time-based program (Part 1.1).</p>
R2	The entity uses performance-based maintenance intervals in its PSMP but failed to reduce Countable Events to no more than 4% within three years.	NA	The entity uses performance-based maintenance intervals in its PSMP but failed to reduce Countable Events to no more than 4% within four years.	<p>The entity uses performance-based maintenance intervals in its PSMP but:</p> <ol style="list-style-type: none"> 1) Failed to establish the technical justification described within Requirement R2 for the initial use of the performance-based PSMP <p>OR</p> <ol style="list-style-type: none"> 2) Failed to reduce Countable Events to no more than 4% within five years <p>OR</p>

Requirement Number	Lower VSL	Moderate VSL	High VSL	Severe VSL
				3) Maintained a Segment with less than 60 Components OR 4) Failed to: <ul style="list-style-type: none"> • Annually update the list of Components, OR • Annually perform maintenance on the greater of 5% of the Segment population or 3 Components, OR • Annually analyze the program activities and results for each Segment.
R3	For Components included within a time-based maintenance program, the entity failed to maintain 5% or less of the total Components included within a specific Component Type in accordance with the minimum maintenance activities and maximum maintenance intervals prescribed within Tables 1-1 through 1-5, Table 2, Table 3, Tables 4-1 through 4-23, and Table 5.	For Components included within a time-based maintenance program, the entity failed to maintain more than 5% but 10% or less of the total Components included within a specific Component Type in accordance with the minimum maintenance activities and maximum maintenance intervals prescribed within Tables 1-1 through 1-5, Table 2, Table 3, Tables 4-1 through 4-23, and Table 5.	For Components included within a time-based maintenance program, the entity failed to maintain more than 10% but 15% or less of the total Components included within a specific Component Type in accordance with the minimum maintenance activities and maximum maintenance intervals prescribed within Tables 1-1 through 1-5, Table 2, Table 3, Tables 4-1 through 4-23, and Table 5.	For Components included within a time-based maintenance program, the entity failed to maintain more than 15% of the total Components included within a specific Component Type in accordance with the minimum maintenance activities and maximum maintenance intervals prescribed within Tables 1-1 through 1-5, Table 2, Table 3, Tables 4-1 through 4-23, and Table 5.

Requirement Number	Lower VSL	Moderate VSL	High VSL	Severe VSL
R4	For Components included within a performance-based maintenance program, the entity failed to maintain 5% or less of the annual scheduled maintenance for a specific Component Type in accordance with their performance-based PSMP.	For Components included within a performance-based maintenance program, the entity failed to maintain more than 5% but 10% or less of the annual scheduled maintenance for a specific Component Type in accordance with their performance-based PSMP.	For Components included within a performance-based maintenance program, the entity failed to maintain more than 10% but 15% or less of the annual scheduled maintenance for a specific Component Type in accordance with their performance-based PSMP.	For Components included within a performance-based maintenance program, the entity failed to maintain more than 15% of the annual scheduled maintenance for a specific Component Type in accordance with their performance-based PSMP.
R5	The entity failed to undertake efforts to correct 5 or fewer identified Unresolved Maintenance Issues.	The entity failed to undertake efforts to correct greater than 5 but less than or equal to 10 identified Unresolved Maintenance Issues.	The entity failed to undertake efforts to correct greater than 10 but less than or equal to 15 identified Unresolved Maintenance Issues.	The entity failed to undertake efforts to correct greater than 15 identified Unresolved Maintenance Issues.

D. Regional Variances

None.

E. Interpretations

None.

Supplemental Reference Documents

The following documents present a detailed discussion about determination of maintenance intervals and other useful information regarding establishment of a maintenance program.

1. *Supplementary Reference and FAQ - PRC-005-~~64~~ Protection System Maintenance*, Protection System Maintenance and Testing Standard Drafting Team (April 201~~5~~4)
2. *Considerations for Maintenance and Testing of Auto-reclosing Schemes*, NERC System Analysis and Modeling Subcommittee, and NERC System Protection and Control Subcommittee (November 2012)
3. *Sudden Pressure Relays and Other Devices that Respond to Non-Electrical Quantities – SPCS Input for Standard Development in Response to FERC Order No. 758*, NERC System Protection and Control Subcommittee (December 2013)
4. *Sudden Pressure Relays and Other Devices that Respond to Non-Electrical Quantities – Supplemental Information to Support Project 2007-17.3: Protection System Maintenance and Testing* (October 31, 2014)

Version History

Version	Date	Action	Change Tracking
0	February 8, 2005	Adopted by NERC Board of Trustees	New.
1	February 7, 2006	Adopted by NERC Board of Trustees	<ol style="list-style-type: none"> 1. Changed incorrect use of certain hyphens (-) to “en dash” (–) and “em dash (—).” 2. Added “periods” to items where appropriate. Changed “Timeframe” to “Time Frame” in item D, 1.2.
1a	February 17, 2011	Adopted by NERC Board of Trustees	Added Appendix 1 - Interpretation regarding applicability of standard to protection of radially connected transformers developed in Project 2009-17.

Version	Date	Action	Change Tracking
1b	November 5, 2009	Adopted by NERC Board of Trustees	Interpretation of R1, R1.1, and R1.2 developed by Project 2009-10.
1b	February 3, 2012	FERC Order approving revised definition of “Protection System”	Per footnote 8 of FERC’s order, the definition of “Protection System” supersedes interpretation “b” of PRC-005-1b upon the effective date of the modified definition (i.e., April 1, 2013). <i>See N. Amer. Elec. Reliability Corp., 138 FERC ¶ 61,095 (February 3, 2012).</i>
1.1b	May 9, 2012	Adopted by NERC Board of Trustees	Errata change developed by Project 2010-07, clarified inclusion of generator interconnection Facility in Generator Owner’s responsibility.
2	November 7, 2012	Adopted by NERC Board of Trustees	Project 2007-17 - Complete revision, absorbing maintenance requirements from PRC-005-1.1b, PRC-008-0, PRC-011-0, PRC-017-0.
2	October 17, 2013	Approved by NERC Standards Committee	Errata Change: The Standards Committee approved an errata change to the implementation plan for PRC-005-2 to add the phrase “or as otherwise made effective pursuant to the laws applicable to such ERO governmental authorities;” to the second sentence under the “Retirement of Existing Standards” section. (no change to standard version number)
2	March 7, 2014	Adopted by NERC Board of Trustees	Modified R1 VSL in response to FERC directive (no change to standard version number).
2(i)	November 13, 2014	Adopted by NERC Board of Trustees	Applicability section revised by Project 2014-01 to clarify application of Requirements to BES dispersed power producing resources.

Version	Date	Action	Change Tracking
2(ii)	November 13, 2014	Adopted by NERC Board of Trustees	Replaced references to Special Protection System and SPS with Remedial Action Scheme and RAS.
3	November 7, 2013	Adopted by the NERC Board of Trustees	Revised to address the FERC directive in Order No. 758 to include Automatic Reclosing in maintenance programs.
3	February 12, 2014	Approved by NERC Standards Committee	Errata Change: The Standards Committee approved errata changes to correct capitalization of certain defined terms within the definitions of “Unresolved Maintenance Issue” and “Protection System Maintenance Program”. The changes will be reflected in the definitions section of PRC-005-3 for “Unresolved Maintenance Issue” and in the NERC Glossary of Terms for “Protection System Maintenance Program”. (no change to standard version number)
3	March 7, 2014	Adopted by NERC Board of Trustees	Modified R1 VSL in response to FERC directive (no change to standard version number).
3(i)	November 13, 2014	Adopted by NERC Board of Trustees	Applicability section revised by Project 2014-01 to clarify application of Requirements to BES dispersed power producing resources.
3(ii)	November 13, 2014	Adopted by NERC Board of Trustees	Replaced references to Special Protection System and SPS with Remedial Action Scheme and RAS.
4	November 13, 2014	Adopted by NERC Board of Trustees	Added Sudden Pressure Relaying in response to FERC Order No. 758.

Version	Date	Action	Change Tracking
5	TBD		Applicability section revised by Project 2014-01 to clarify application of Requirements to BES dispersed power producing resources.
<u>6</u>	<u>TBD</u>		<u>Revised to add supervisory relays to Automatic Reclosing in accordance with the directives in FERC Order 803.</u>

Table 1-1 Component Type - Protective Relay Excluding distributed UFLS and distributed UVLS (see Table 3)		
Component Attributes	Maximum Maintenance Interval ³	Maintenance Activities
Any unmonitored protective relay not having all the monitoring attributes of a category below.	6 Calendar Years	For all unmonitored relays: <ul style="list-style-type: none"> • Verify that settings are as specified For non-microprocessor relays: <ul style="list-style-type: none"> • Test and, if necessary calibrate For microprocessor relays: <ul style="list-style-type: none"> • Verify operation of the relay inputs and outputs that are essential to proper functioning of the Protection System. • Verify acceptable measurement of power system input values.
Monitored microprocessor protective relay with the following: <ul style="list-style-type: none"> • Internal self-diagnosis and alarming (see Table 2). • Voltage and/or current waveform sampling three or more times per power cycle, and conversion of samples to numeric values for measurement calculations by microprocessor electronics. • Alarming for power supply failure (see Table 2). 	12 Calendar Years	Verify: <ul style="list-style-type: none"> • Settings are as specified. • Operation of the relay inputs and outputs that are essential to proper functioning of the Protection System. • Acceptable measurement of power system input values.

³ For the tables in this standard, a calendar year starts on the first day of a new year (January 1) after a maintenance activity has been completed. For the tables in this standard, a calendar month starts on the first day of the first month after a maintenance activity has been completed.

Table 1-1 Component Type - Protective Relay Excluding distributed UFLS and distributed UVLS (see Table 3)		
Component Attributes	Maximum Maintenance Interval ³	Maintenance Activities
Monitored microprocessor protective relay with preceding row attributes and the following: <ul style="list-style-type: none"> • Ac measurements are continuously verified by comparison to an independent ac AC measurement source, with alarming for excessive error (See Table 2). • Some or all binary or status inputs and control outputs are monitored by a process that continuously demonstrates ability to perform as designed, with alarming for failure (See Table 2). • Alarming for change of settings (See Table 2). 	12 Calendar Years	Verify only the unmonitored relay inputs and outputs that are essential to proper functioning of the Protection System.

Table 1-2 Component Type - Communications Systems Excluding distributed UFLS and distributed UVLS (see Table 3)		
Component Attributes	Maximum Maintenance Interval	Maintenance Activities
Any unmonitored communications system necessary for correct operation of protective functions, and not having all the monitoring attributes of a category below.	4 Calendar Months	Verify that the communications system is functional.
	6 Calendar Years	Verify that the communications system meets performance criteria pertinent to the communications technology applied (e.g. signal level, reflected power, or data error rate). Verify operation of communications system inputs and outputs that are essential to proper functioning of the Protection System.
Any communications system with continuous monitoring or periodic automated testing for the presence of the channel function, and alarming for loss of function (See Table 2).	12 Calendar Years	Verify that the communications system meets performance criteria pertinent to the communications technology applied (e.g. signal level, reflected power, or data error rate). Verify operation of communications system inputs and outputs that are essential to proper functioning of the Protection System.
Any communications system with all of the following: <ul style="list-style-type: none"> • Continuous monitoring or periodic automated testing for the performance of the channel using criteria pertinent to the communications technology applied (e.g. signal level, reflected power, or data error rate, and alarming for excessive performance degradation). (See Table 2) • Some or all binary or status inputs and control outputs are monitored by a process that continuously demonstrates ability to perform as designed, with alarming for failure (See Table 2). 	12 Calendar Years	Verify only the unmonitored communications system inputs and outputs that are essential to proper functioning of the Protection System

Table 1-3 Component Type - Voltage and Current Sensing Devices Providing Inputs to Protective Relays Excluding distributed UFLS and distributed UVLS (see Table 3)		
Component Attributes	Maximum Maintenance Interval	Maintenance Activities
Any voltage and current sensing devices not having monitoring attributes of the category below.	12 Calendar Years	Verify that current and voltage signal values are provided to the protective relays.
Voltage and Current Sensing devices connected to microprocessor relays with AC measurements <u>that</u> are continuously verified by comparison of sensing input value, as measured by the microprocessor relay, to an independent <u>AC</u> measurement source, with alarming for unacceptable error or failure (see Table 2).	No periodic maintenance specified	None.

Table 1-4(a) Component Type – Protection System Station d e-DC Supply Using Vented Lead-Acid (VLA) Batteries Excluding distributed UFLS and distributed UVLS (see Table 3)		
Protection System Station d e-DC supply used only for non-BES interrupting devices for RAS, non-distributed UFLS systems, or non-distributed UVLS systems is excluded (see Table 1-4(e)).		
Component Attributes	Maximum Maintenance Interval	Maintenance Activities
Protection System Station d e-DC supply using Vented Lead-Acid (VLA) batteries not having monitoring attributes of Table 1-4(f).	4 Calendar Months	Verify: <ul style="list-style-type: none"> • Station de-DC supply voltage Inspect: <ul style="list-style-type: none"> • Electrolyte level • For unintentional grounds
	18 Calendar Months	Verify: <ul style="list-style-type: none"> • Float voltage of battery charger • Battery continuity • Battery terminal connection resistance • Battery intercell or unit-to-unit connection resistance Inspect: <ul style="list-style-type: none"> • Cell condition of all individual battery cells where cells are visible – or measure battery cell/unit internal ohmic values where the cells are not visible • Physical condition of battery rack

Table 1-4(a)

Component Type – Protection System Station ~~dc-DC~~ Supply Using Vented Lead-Acid (VLA) Batteries
 Excluding distributed UFLS and distributed UVLS (see Table 3)

Protection System Station ~~dc-DC~~ supply used only for non-BES interrupting devices for RAS, non-distributed UFLS systems, or non-distributed UVLS systems is excluded (see Table 1-4(e)).

Component Attributes	Maximum Maintenance Interval	Maintenance Activities
	18 Calendar Months -or- 6 Calendar Years	Verify that the station battery can perform as manufactured by evaluating cell/unit measurements indicative of battery performance (e.g. internal ohmic values or float current) against the station battery baseline. -or- Verify that the station battery can perform as manufactured by conducting a performance or modified performance capacity test of the entire battery bank.

Table 1-4(b) Component Type – Protection System Station dc-DC Supply Using Valve-Regulated Lead-Acid (VRLA) Batteries Excluding distributed UFLS and distributed UVLS (see Table 3)		
Protection System Station dc-DC supply used only for non-BES interrupting devices for RAS, non-distributed UFLS systems, or non-distributed UVLS systems is excluded (see Table 1-4(e)).		
Component Attributes	Maximum Maintenance Interval	Maintenance Activities
Protection System Station dc-DC supply with Valve Regulated Lead-Acid (VRLA) batteries not having monitoring attributes of Table 1-4(f).	4 Calendar Months	Verify: <ul style="list-style-type: none"> • Station dc-DC supply voltage Inspect: <ul style="list-style-type: none"> • For unintentional grounds
	6 Calendar Months	Inspect: <ul style="list-style-type: none"> • Condition of all individual units by measuring battery cell/unit internal ohmic values.
	18 Calendar Months	Verify: <ul style="list-style-type: none"> • Float voltage of battery charger • Battery continuity • Battery terminal connection resistance • Battery intercell or unit-to-unit connection resistance Inspect: <ul style="list-style-type: none"> • Physical condition of battery rack

<p style="text-align: center;">Table 1-4(b)</p> <p style="text-align: center;">Component Type – Protection System Station dcDC Supply Using Valve-Regulated Lead-Acid (VRLA) Batteries</p> <p style="text-align: center;">Excluding distributed UFLS and distributed UVLS (see Table 3)</p> <p style="text-align: center;">Protection System Station dcDC supply used only for non-BES interrupting devices for RAS, non-distributed UFLS systems, or non-distributed UVLS systems is excluded (see Table 1-4(e)).</p>		
Component Attributes	Maximum Maintenance Interval	Maintenance Activities
	6 Calendar Months -or- 3 Calendar Years	Verify that the station battery can perform as manufactured by evaluating cell/unit measurements indicative of battery performance (e.g. internal ohmic values or float current) against the station battery baseline. -or- Verify that the station battery can perform as manufactured by conducting a performance or modified performance capacity test of the entire battery bank.

Table 1-4(c) Component Type – Protection System Station dC-DC Supply Using Nickel-Cadmium (NiCad) Batteries Excluding distributed UFLS and distributed UVLS (see Table 3)		
Protection System Station dC-DC supply used only for non-BES interrupting devices for RAS, non-distributed UFLS system, or non-distributed UVLS systems is excluded (see Table 1-4(e)).		
Component Attributes	Maximum Maintenance Interval	Maintenance Activities
Protection System Station dC-DC supply Nickel-Cadmium (NiCad) batteries not having monitoring attributes of Table 1-4(f).	4 Calendar Months	Verify: <ul style="list-style-type: none"> • Station dC-DC supply voltage Inspect: <ul style="list-style-type: none"> • Electrolyte level • For unintentional grounds
	18 Calendar Months	Verify: <ul style="list-style-type: none"> • Float voltage of battery charger • Battery continuity • Battery terminal connection resistance • Battery intercell or unit-to-unit connection resistance Inspect: <ul style="list-style-type: none"> • Cell condition of all individual battery cells. • Physical condition of battery rack

Table 1-4(c) Component Type – Protection System Station dc-DC Supply Using Nickel-Cadmium (NiCad) Batteries Excluding distributed UFLS and distributed UVLS (see Table 3)		
Protection System Station dc-DC supply used only for non-BES interrupting devices for RAS, non-distributed UFLS system, or non-distributed UVLS systems is excluded (see Table 1-4(e)).		
Component Attributes	Maximum Maintenance Interval	Maintenance Activities
	6 Calendar Years	Verify that the station battery can perform as manufactured by conducting a performance or modified performance capacity test of the entire battery bank.

Table 1-4(d) Component Type – Protection System Station dc-DC Supply Using Non Battery Based Energy Storage Excluding distributed UFLS and distributed UVLS (see Table 3)		
Protection System Station dc-DC supply used only for non-BES interrupting devices for RAS, non-distributed UFLS system, or non-distributed UVLS systems is excluded (see Table 1-4(e)).		
Component Attributes	Maximum Maintenance Interval	Maintenance Activities
Any Protection System station dc-DC supply not using a battery and not having monitoring attributes of Table 1-4(f).	4 Calendar Months	Verify: <ul style="list-style-type: none"> • Station dc-DC supply voltage Inspect: <ul style="list-style-type: none"> • For unintentional grounds
	18 Calendar Months	Inspect: Condition of non-battery based dc-DC supply
	6 Calendar Years	Verify that the dc-DC supply can perform as manufactured when ac-AC power is not present.

Table 1-4(e) Component Type – Protection System Station dc -DC Supply for non-BES Interrupting Devices for RAS, non-distributed UFLS, and non-distributed UVLS systems		
Component Attributes	Maximum Maintenance Interval	Maintenance Activities
Any Protection System dc -DC supply used for tripping only non-BES interrupting devices as part of a RAS, non-distributed UFLS, or non-distributed UVLS system and not having monitoring attributes of Table 1-4(f).	When control circuits are verified (See Table 1-5)	Verify Station dc -DC supply voltage.

Table 1-4(f) Exclusions for Protection System Station dc -DC Supply Monitoring Devices and Systems		
Component Attributes	Maximum Maintenance Interval	Maintenance Activities
Any station dc -DC supply with high and low voltage monitoring and alarming of the battery charger voltage to detect charger overvoltage and charger failure (See Table 2).	No periodic maintenance specified	No periodic verification of station dc -DC supply voltage is required.
Any battery based station dc -DC supply with electrolyte level monitoring and alarming in every cell (See Table 2).		No periodic inspection of the electrolyte level for each cell is required.
Any station dc -DC supply with unintentional dc -DC ground monitoring and alarming (See Table 2).		No periodic inspection of unintentional dc -DC grounds is required.
Any station dc -DC supply with charger float voltage monitoring and alarming to ensure correct float voltage is being applied on the station dc -DC supply (See Table 2).		No periodic verification of float voltage of battery charger is required.
Any battery based station dc -DC supply with monitoring and alarming of battery string continuity (See Table 2).		No periodic verification of the battery continuity is required.
Any battery based station dc -DC supply with monitoring and alarming of the intercell and/or terminal connection detail resistance of the entire battery (See Table 2).		No periodic verification of the intercell and terminal connection resistance is required.
Any Valve Regulated Lead-Acid (VRLA) or Vented Lead-Acid (VLA) station battery with internal ohmic value or float current monitoring and alarming, and evaluating present values relative to baseline internal ohmic values for every cell/unit (See Table 2).		No periodic evaluation relative to baseline of battery cell/unit measurements indicative of battery performance is required to verify the station battery can perform as manufactured.
Any Valve Regulated Lead-Acid (VRLA) or Vented Lead-Acid (VLA) station battery with monitoring and alarming of each cell/unit internal ohmic value (See Table 2).		No periodic inspection of the condition of all individual units by measuring battery cell/unit internal ohmic values of a station VRLA or Vented Lead-Acid (VLA) battery is required.

Table 1-5 Component Type - Control Circuitry Associated With Protective Functions Excluding distributed UFLS and distributed UVLS (see Table 3), Automatic Reclosing (see Table 4), and Sudden Pressure Relaying (see Table 5) Note: Table requirements apply to all Control Circuitry Components of Protection Systems, and RAS except as noted.		
Component Attributes	Maximum Maintenance Interval	Maintenance Activities
Trip coils or actuators of circuit breakers, interrupting devices, or mitigating devices (regardless of any monitoring of the control circuitry).	6 Calendar Years	Verify that each trip coil is able to operate the circuit breaker, interrupting device, or mitigating device.
Electromechanical lockout devices which are directly in a trip path from the protective relay to the interrupting device trip coil (regardless of any monitoring of the control circuitry).	6 Calendar Years	Verify electrical operation of electromechanical lockout devices.
Unmonitored control circuitry associated with RAS. (See Table 4-2(b) for RAS which include Automatic Reclosing.)	12 Calendar Years	Verify all paths of the control circuits essential for proper operation of the RAS.
Unmonitored control circuitry associated with protective functions inclusive of all auxiliary relays.	12 Calendar Years	Verify all paths of the trip circuits inclusive of all auxiliary relays through the trip coil(s) of the circuit breakers or other interrupting devices.
Control circuitry associated with protective functions and/or RAS whose integrity is monitored and alarmed (See Table 2).	No periodic maintenance specified	None.

<p align="center">Table 2 – Alarming Paths and Monitoring</p> <p align="center">In Tables 1-1 through 1-5, Table 3, Tables 4-1 through 4-23, and Table 5 alarm attributes used to justify extended maximum maintenance intervals and/or reduced maintenance activities are subject to the following maintenance requirements</p>		
Component Attributes	Maximum Maintenance Interval	Maintenance Activities
<p>Any alarm path through which alarms in Tables 1-1 through 1-5, Table 3, Tables 4-1 through 4-23, and Table 5 are conveyed from the alarm origin to the location where corrective action can be initiated, and not having all the attributes of the “Alarm Path with monitoring” category below.</p> <p>Alarms are reported within 24 hours of detection to a location where corrective action can be initiated.</p>	12 Calendar Years	Verify that the alarm path conveys alarm signals to a location where corrective action can be initiated.
<p>Alarm Path with monitoring:</p> <p>The location where corrective action is taken receives an alarm within 24 hours for failure of any portion of the alarming path from the alarm origin to the location where corrective action can be initiated.</p>	No periodic maintenance specified	None.

Table 3 Maintenance Activities and Intervals for distributed UFLS and distributed UVLS Systems		
Component Attributes	Maximum Maintenance Interval	Maintenance Activities
Any unmonitored protective relay not having all the monitoring attributes of a category below.	6 Calendar Years	<p>Verify that settings are as specified.</p> <p>For non-microprocessor relays:</p> <ul style="list-style-type: none"> • Test and, if necessary calibrate. <p>For microprocessor relays:</p> <ul style="list-style-type: none"> • Verify operation of the relay inputs and outputs that are essential to proper functioning of the Protection System. • Verify acceptable measurement of power system input values.
<p>Monitored microprocessor protective relay with the following:</p> <ul style="list-style-type: none"> • Internal self-diagnosis and alarming (See Table 2). • Voltage and/or current waveform sampling three or more times per power cycle, and conversion of samples to numeric values for measurement calculations by microprocessor electronics. <p>Alarming for power supply failure (See Table 2).</p>	12 Calendar Years	<p>Verify:</p> <ul style="list-style-type: none"> • Settings are as specified. • Operation of the relay inputs and outputs that are essential to proper functioning of the Protection System. • Acceptable measurement of power system input values.
<p>Monitored microprocessor protective relay with preceding row attributes and the following:</p> <ul style="list-style-type: none"> • Ac measurements are continuously verified by comparison to an independent ac AC measurement source, with alarming for excessive error (See Table 2). 	12 Calendar Years	<p>Verify only the unmonitored relay inputs and outputs that are essential to proper functioning of the Protection System.</p>

Table 3 Maintenance Activities and Intervals for distributed UFLS and distributed UVLS Systems		
Component Attributes	Maximum Maintenance Interval	Maintenance Activities
<ul style="list-style-type: none"> Some or all binary or status inputs and control outputs are monitored by a process that continuously demonstrates ability to perform as designed, with alarming for failure (See Table 2). Alarming for change of settings (See Table 2).		
Voltage and/or current sensing devices associated with UFLS or UVLS systems.	12 Calendar Years	Verify that current and/or voltage signal values are provided to the protective relays.
Protection System dc DC supply for tripping non-BES interrupting devices used only for a UFLS or UVLS system.	12 Calendar Years	Verify Protection System dc DC supply voltage.
Control circuitry between the UFLS or UVLS relays and electromechanical lockout and/or tripping auxiliary devices (excludes non-BES interrupting device trip coils).	12 Calendar Years	Verify the path from the relay to the lockout and/or tripping auxiliary relay (including essential supervisory logic).
Electromechanical lockout and/or tripping auxiliary devices associated only with UFLS or UVLS systems (excludes non-BES interrupting device trip coils).	12 Calendar Years	Verify electrical operation of electromechanical lockout and/or tripping auxiliary devices.
Control circuitry between the electromechanical lockout and/or tripping auxiliary devices and the non-BES interrupting devices in UFLS or UVLS systems, or between UFLS or UVLS relays (with no interposing electromechanical lockout or auxiliary device) and the non-BES interrupting devices (excludes non-BES interrupting device trip coils).	No periodic maintenance specified	None.
Trip coils of non-BES interrupting devices in UFLS or UVLS systems.	No periodic maintenance specified	None.

Table 4-1 Maintenance Activities and Intervals for Automatic Reclosing Components Component Type – Reclosing <u>and Supervisory</u> Relay		
Note: In cases where Components of Automatic Reclosing are common to Components listed in Table 1-1 through 1-5, the Components only need to be tested once during a distinct maintenance interval.		
Component Attributes	Maximum Maintenance Interval	Maintenance Activities
Any unmonitored reclosing relay <u>or supervisory relay</u> not having all the monitoring attributes of a category below.	6 Calendar Years	Verify that settings are as specified. For non-microprocessor relays: <ul style="list-style-type: none"> • Test and, if necessary calibrate For microprocessor relays: <ul style="list-style-type: none"> • <u>Verify operation of the relay inputs and outputs that are essential to proper functioning of the Automatic Reclosing.</u> <u>For microprocessor supervisory relays:</u> <ul style="list-style-type: none"> • <u>Verify acceptable measurement of power system input values.</u>
Monitored microprocessor reclosing relay <u>or supervisory relay</u> with the following: <ul style="list-style-type: none"> • Internal self-diagnosis and alarming (See Table 2). • <u>Alarming for power supply failure (See Table 2).</u> <u>For supervisory relay:</u> <ul style="list-style-type: none"> • <u>Voltage waveform sampling three or more times per power cycle, and conversion of samples to numeric values for measurement calculations by microprocessor electronics.</u> 	12 Calendar Years	Verify: <ul style="list-style-type: none"> • Settings are as specified. Operation of the relay inputs and outputs that are essential to proper functioning of the Automatic Reclosing. <u>For supervisory relays:</u> <ul style="list-style-type: none"> • <u>Verify acceptable measurement of power system input values.</u>

Table 4-1

Maintenance Activities and Intervals for Automatic Reclosing Components

Component Type – Reclosing and Supervisory Relay

Note: In cases where Components of Automatic Reclosing are common to Components listed in Table 1-1 through 1-5, the Components only need to be tested once during a distinct maintenance interval.

<u>Component Attributes</u>	<u>Maximum Maintenance Interval</u>	<u>Maintenance Activities</u>
<p><u>Monitored microprocessor reclosing relay or supervisory relay with preceding row attributes and the following:</u></p> <ul style="list-style-type: none"> • <u>Some or all binary or status inputs and control outputs are monitored by a process that continuously demonstrates ability to perform as designed, with alarming for failure (See Table 2).</u> • <u>Alarming for change of settings (See Table 2).</u> <p><u>For supervisory relay:</u></p> <ul style="list-style-type: none"> • <u>AC measurements are continuously verified by comparison to an independent AC measurement source, with alarming for excessive error (See Table 2).</u> 	<p><u>12 Calendar Years</u></p>	<p><u>Verify only the unmonitored relay inputs and outputs that are essential to proper functioning of the Automatic Reclosing.</u></p>

Table 4-2(a)

Maintenance Activities and Intervals for Automatic Reclosing Components

Component Type – Control Circuitry Associated with Reclosing and Supervisory Relays that are NOT an Integral Part of an RAS

Note: In cases where Components of Sudden Pressure Relaying are common to Components listed in Table 1-5, the Components only need to be tested once during a distinct maintenance interval.

Component Attributes	Maximum Maintenance Interval	Maintenance Activities
Unmonitored Control circuitry associated with Automatic Reclosing that is not an integral part of an RAS.	12 Calendar Years	Verify that Automatic Reclosing, upon initiation, does not issue a premature closing command to the close circuitry.
Control circuitry associated with Automatic Reclosing that is not part of an RAS and is monitored and alarmed for conditions that would result in a premature closing command. (See Table 2)	No periodic maintenance specified	None.

Table 4-2(b)

Maintenance Activities and Intervals for Automatic Reclosing Components

Component Type – Control Circuitry Associated with Reclosing and Supervisory Relays that ARE an Integral Part of an RAS

Note: In cases where Components of Sudden Pressure Relaying are common to Components listed in Table 1-5, the Components only need to be tested once during a distinct maintenance interval.

Component Attributes	Maximum Maintenance Interval	Maintenance Activities
Close coils or actuators of circuit breakers or similar devices that are used in conjunction with Automatic Reclosing as part of an RAS (regardless of any monitoring of the control circuitry).	6 Calendar Years	Verify that each close coil or actuator is able to operate the circuit breaker or mitigating device.
Unmonitored close control circuitry associated with Automatic Reclosing used as an integral part of an RAS.	12 Calendar Years	Verify all paths of the control circuits associated with Automatic Reclosing that are essential for proper operation of the RAS.
Control circuitry associated with Automatic Reclosing that is an integral part of an RAS whose integrity is monitored and alarmed. (See Table 2)	No periodic maintenance specified	None.

Table 4-3 Maintenance Activities and Intervals for Automatic Reclosing Components Component Type – Voltage Sensing Devices Associated with Supervisory Relays Note: In cases where Components of Sudden Pressure Relaying are common to Components listed in Table 1-5, the Components only need to be tested once during a distinct maintenance interval.		
<u>Component Attributes</u>	<u>Maximum Maintenance Interval</u>	<u>Maintenance Activities</u>
<u>Any voltage sensing devices not having monitoring attributes of the category below.</u>	<u>12 Calendar Years</u>	<u>Verify that voltage signal values are provided to the supervisory relays.</u>
<u>Voltage sensing devices that are connected to microprocessor supervisory relays with AC measurements that are continuously verified by comparison of sensing input value, as measured by the microprocessor relay, to an independent AC measurement source, with alarming for unacceptable error or failure. (See Table 2)</u>	<u>No periodic maintenance specified</u>	<u>None.</u>

Table 5 Maintenance Activities and Intervals for Sudden Pressure Relaying		
Note: In cases where Components of Sudden Pressure Relaying are common to Components listed in Table 1-5, the Components only need to be tested once during a distinct maintenance interval.		
Component Attributes	Maximum Maintenance Interval	Maintenance Activities
Any fault pressure relay.	6 Calendar Years	Verify the pressure or flow sensing mechanism is operable.
Electromechanical lockout devices which are directly in a trip path from the fault pressure relay to the interrupting device trip coil (regardless of any monitoring of the control circuitry).	6 Calendar Years	Verify electrical operation of electromechanical lockout devices.
Unmonitored control circuitry associated with Sudden Pressure Relaying.	12 Calendar Years	Verify all paths of the trip circuits inclusive of all auxiliary relays through the trip coil(s) of the circuit breakers or other interrupting devices.
Control circuitry associated with Sudden Pressure Relaying whose integrity is monitored and alarmed (See Table 2).	No periodic maintenance specified	None.

PRC-005 — Attachment A

Criteria for a Performance-Based Protection System Maintenance Program

Purpose: To establish a technical basis for initial and continued use of a performance-based Protection System Maintenance Program (PSMP).

To establish the technical justification for the initial use of a performance-based PSMP:

1. Develop a list with a description of Components included in each designated Segment, with a minimum Segment population of 60 Components.
2. Maintain the Components in each Segment according to the time-based maximum allowable intervals established in Tables 1-1 through 1-5, Table 3, Tables 4-1 through 4-~~32~~, and Table 5 until results of maintenance activities for the Segment are available for a minimum of 30 individual Components of the Segment.
3. Document the maintenance program activities and results for each Segment, including maintenance dates and Countable Events for each included Component.
4. Analyze the maintenance program activities and results for each Segment to determine the overall performance of the Segment and develop maintenance intervals.
5. Determine the maximum allowable maintenance interval for each Segment such that the Segment experiences Countable Events on no more than 4% of the Components within the Segment, for the greater of either the last 30 Components maintained or all Components maintained in the previous year.

To maintain the technical justification for the ongoing use of a performance-based PSMP:

1. At least annually, update the list of Components and Segments and/or description if any changes occur within the Segment.
2. Perform maintenance on the greater of 5% of the Components (addressed in the performance based PSMP) in each Segment or 3 individual Components within the Segment in each year.
3. For the prior year, analyze the maintenance program activities and results for each Segment to determine the overall performance of the Segment.
4. Using the prior year's data, determine the maximum allowable maintenance interval for each Segment such that the Segment experiences Countable Events on no more than 4% of the Components within the Segment, for the greater of either the last 30 Components maintained or all Components maintained in the previous year.

If the Components in a Segment maintained through a performance-based PSMP experience 4% or more Countable Events, develop, document, and implement an action plan to reduce the Countable Events to less than 4% of the Segment population within 3 years.

Rationale:

During development of this standard, text boxes were embedded within the standard to explain the rationale for various parts of the standard. Upon BOT approval, the text from the rationale text boxes was moved to this section.

Implementation Plan

Project 2007-17.4 PRC-005 FERC Order No. 803 Directive
PRC-005-6

Standards Involved

Approval:

- PRC-005-6 – Protection System, Automatic Reclosing, and Sudden Pressure Relaying Maintenance

Retirement:

- PRC-005-5 – Protection System, Automatic Reclosing, and Sudden Pressure Relaying Maintenance
- PRC-005-4 Protection System, Automatic Reclosing, and Sudden Pressure Relaying Maintenance
- PRC-005-3 (ii) Protection System and Automatic Reclosing Maintenance
- PRC-005-3 (i) Protection System and Automatic Reclosing Maintenance
- PRC-005-3 Protection System and Automatic Reclosing Maintenance
- PRC-005-2 (ii) Protection System Maintenance
- PRC-005-2 (i) Protection System Maintenance
- PRC-005-2 Protection System Maintenance
- PRC-005-1b – Transmission and Generation Protection System Maintenance and Testing
- PRC-008-0 – Implementation and Documentation of Underfrequency Load Shedding Equipment Maintenance Program
- PRC-011-0 – Undervoltage Load Shedding System Maintenance and Testing
- PRC-017-0 – Special Protection System Maintenance and Testing

Prerequisite Approvals:

N/A

Background:

In Order No. 803, FERC approved Standard PRC-005-3 and, in Paragraph 31, directed NERC to:

"...develop modifications to PRC-005-3 to include supervisory devices associated with auto-reclosing relay schemes to which the Reliability Standard applies. Further, we clarify that NERC's proposal regarding the scope of supervisory devices is an acceptable approach to satisfy the Commission directive. Specifically, NERC proposed in its NOPR comments, and we find acceptable, that the scope of the supervisory devices to be encompassed in the Reliability Standard are those providing voltage supervision, supervisory inputs associated with selective auto-reclosing, and sync-check relays that are part of a reclosing scheme covered by PRC-005-3."

This Implementation Plan adds:

- The implementation of changes relating to maintenance and testing of supervisory relays and associated voltage sensing devices related to Automatic Reclosing.
- The phased implementation approach included in the approved PRC-005-2 and proposed PRC-005-2(i) will remain as-is.
- This implementation schedule lays out the implementation timeline for the currently effective PRC-005-2 and proposed PRC-005-2(i), and combines the implementation plans for the approved PRC-005-3 and all subsequent pending PRC-005 versions (PRC-005-2(ii), PRC-005-3(i), PRC-005-3(ii), PRC-005-4 and PRC-005-5), making all versions from PRC-005-3 onwards effective on the same day PRC-005-6 becomes effective. The effective dates for the various phases specified in PRC-005-3 and each subsequent version of PRC-005 will align with the effective dates for those phases included in the PRC-005-6 Implementation Plan. For the pending versions that do not entail phased implementation, the versions will become effective on the date PRC-005-6 first becomes effective.
- Notwithstanding any order to the contrary, PRC-005-2(ii), PRC-005-3, PRC-005-3(i), PRC-005-3(ii), PRC-005-4 and PRC-005-5 will not become effective, and PRC-005-2 will remain in effect and not be retired until the effective date of the PRC-005-6 standard under this implementation plan.¹

The Implementation Plan reflects consideration of the following:

1. The requirements set forth in the proposed standard, which carry forward requirements from PRC-005-2, PRC-005-2(i), PRC-005-2(ii), PRC-005-3, PRC-005-3(i), PRC-005-3(ii), PRC-005-4 and PRC-005-5, establish minimum maintenance activities for Protection System, Automatic Reclosing, and Sudden Pressure Relaying Component Types as well as the maximum allowable maintenance intervals for these maintenance activities.

¹ In jurisdictions where previous versions of PRC-005 have not yet become effective according to their implementation plans (even if approved by order), this implementation plan and the PRC-005-6 standard supersedes and replaces the implementation plans and standards for PRC-005-2(i), PRC-005-2(ii), PRC-005-3, PRC-005-3(i), PRC-005-3(ii), PRC-005-4, and PRC-005-5.

2. The maintenance activities established in the various PRC-005 versions may not be presently performed by some registered entities and the established maximum allowable intervals may be shorter than those currently in use by some entities. Therefore, registered entities may not be presently performing a maintenance activity or may be using longer intervals than the maximum allowable intervals established in the PRC-005 standards. For these registered entities, it is unrealistic to become immediately compliant with the new activities or intervals. Further, registered entities should be allowed to become compliant in such a way as to facilitate a continuing PRC-005 maintenance program. The registered entities that have previously been performing maintenance within the newly specified intervals may not have all the documentation needed to demonstrate compliance with all of the maintenance activities specified.
3. The implementation schedule set forth below carries forward the implementation schedules contained in PRC-005-2 and proposed PRC-005-2(i), and combines the implementation schedules for PRC-005-2(ii), PRC-005-3, PRC-005-3(i), PRC-005-3(ii), PRC-005-4 and PRC-005-5. In addition, the implementation schedule includes changes needed to address the addition of Automatic Reclosing supervisory relays and associated voltage sensing devices in PRC-005-6.

General Considerations:

Each Transmission Owner, Generator Owner, and Distribution Provider shall maintain documentation to demonstrate compliance with PRC-005-1b, PRC-008-0, PRC-011-0, and PRC-017-0 until that entity meets all of the requirements of the effective PRC-005-2, or its combined successor standards, in accordance with this Implementation Plan.

While registered entities are implementing the requirements of PRC-005-2 or its combined successor standards, each registered entity must be prepared to identify:

- All of its applicable Protection System, Automatic Reclosing, and Sudden Pressure Relaying Components, and
- Whether each component has last been maintained according to PRC-005-2 (or its combined successor standards), PRC-005-1b, PRC-008-0, PRC-011-0, PRC-017-0, or a combination thereof.

Effective Date

PRC-005-6 shall become effective on the first day of the first calendar quarter after the date that the standard is approved by an applicable governmental authority or as otherwise provided for in a jurisdiction where approval by an applicable governmental authority is required for a standard to go into effect. Where approval by an applicable governmental authority is not required, the standard shall become effective on the first day of the first calendar quarter after the date the standard is adopted by the NERC Board of Trustees or as otherwise provided for in that jurisdiction.

Retirement of Existing Standards:

Standards PRC-005-1b, PRC-008-0, PRC-011-0, and PRC-017-0 shall remain active throughout the phased implementation period of PRC-005-2 and shall be applicable to a registered entity's Protection System Component maintenance activities not yet transitioned to PRC-005-2. Standards PRC-005-1b, PRC-008-0, PRC-011-0, and PRC-017-0 shall be retired at midnight of March 31, 2027 or as otherwise made effective pursuant to the laws applicable to such Electric Reliability Organization (ERO) governmental authorities; or, in those jurisdictions where no regulatory approval is required, at midnight of March 31, 2027.

PRC-005-2 and PRC-005-2(i) shall be retired at midnight of the day immediately prior to the first day of the first calendar quarter, twelve (12) calendar months following applicable regulatory approval of PRC-005-6, or as otherwise made effective pursuant to the laws applicable to such ERO governmental authorities; or, in those jurisdictions where no regulatory approval is required, the first day of the first calendar quarter from the date of Board of Trustees' adoption.

If approved by FERC prior to the approval of PRC-005-6, PRC-005-2(ii), PRC-005-3, PRC-005-3(i), PRC-005-3(ii), PRC-005-4 and PRC-005-5 shall be retired on the date immediately prior to the first day of the first calendar quarter following regulatory approval of PRC-005-6.

Implementation Plan for Definitions:

This section includes all newly defined or revised terms used in the proposed standard. Terms already defined in the Reliability Standards Glossary of Terms (Glossary) are not repeated here. New or revised definitions listed below become approved when the proposed standard is approved by applicable governmental authority or as otherwise provided for in a jurisdiction where approval by an applicable governmental authority is required for a standard to go into effect. When the standard becomes effective, the Glossary definition will be removed from the individual standard and added to the Glossary. The definitions of terms used only in the standard will remain in the standard.

Glossary Definition:

- None

Definitions of Terms Used in the Standard:

Automatic Reclosing – Includes the following Components:

- Reclosing relay
- Supervisory relay(s) or function(s) – relay(s) or function(s) that perform voltage and/or sync check functions that enable or disable operation of the reclosing relay
- Voltage sensing devices associated with the supervisory relay(s)
- Control circuitry associated with the reclosing relay or supervisory relay(s)

Component Type –

- Any one of the five specific elements of a Protection System.
- Any one of the four specific elements of Automatic Reclosing.
- Any one of the two specific elements of Sudden Pressure Relaying.

Component – Any individual discrete piece of equipment included in a Protection System, Automatic Reclosing, or Sudden Pressure Relaying.

Countable Event – A failure of a Component requiring repair or replacement, any condition discovered during the maintenance activities in Tables 1-1 through 1-5, Table 3, Tables 4-1 through 4-3, and Table 5, which requires corrective action or a Protection System Misoperation attributed to hardware failure or calibration failure. Misoperations due to product design errors, software errors, relay settings different from specified settings, Protection System Component, Automatic Reclosing, or Sudden Pressure Relaying configuration or application errors are not included in Countable Events.

Implementation Plan for New or Revised Definitions:

The revised definitions (Automatic Reclosing, Component, and Countable Event) become effective upon the effective date of PRC-005-6.

Implementation Plan for PRC-005-2 and PRC-005-6

All Components with existing requirements under PRC-005-2 and PRC-005-2(i) will continue to follow the PRC-005-2 implementation plan. Those Components and/or Facilities newly introduced by PRC-005-2(ii), PRC-005-3, PRC-005-3(i), PRC-005-3(ii), PRC-005-4, PRC-005-5 and PRC-005-6 (including Sudden Pressure Relaying, Automatic Reclosing Components, and Dispersed Generation Resources) will be covered by the following Implementation Plan:

Requirements R1, R2, and R5:

PRC-005-6: For Automatic Reclosing Components, Sudden Pressure Relaying Components, and Dispersed Generation Resources, entities shall be 100% compliant on the first day of the first calendar quarter twelve (12) months following applicable regulatory approvals of PRC-005-6 or, in those jurisdictions where no regulatory approval is required, on the first day of the first calendar quarter twenty-four (24) months following NERC Board of Trustees' adoption of PRC-005-6 or as otherwise made effective pursuant to the laws applicable to such ERO governmental authorities.

Implementation Plan for Requirements R3 and R4:

PRC-005-6:

1. For Automatic Reclosing Components, Sudden Pressure Relaying Components, and Dispersed Generation Resources maintenance activities with maximum allowable intervals of six (6) calendar years, as established in Tables 4-1, 4-2(a), 4-2(b), 4-3, and 5:
 - The entity shall be at least 30% compliant on the first day of the first calendar quarter thirty-six (36) months following applicable regulatory approval of PRC-005-6 (or, for generating plants with scheduled outage intervals exceeding three years, at the conclusion of the first succeeding maintenance outage) or, in those jurisdictions where no regulatory approval is required, on the first day of the first calendar quarter forty-eight (48) months following NERC Board of Trustees' adoption of PRC-005-6 or as otherwise made effective pursuant to the laws applicable to such ERO governmental authorities.
 - The entity shall be at least 60% compliant on the first day of the first calendar quarter sixty (60) months following applicable regulatory approval of PRC-005-6 or, in those jurisdictions where no regulatory approval is required, on the first day of the first calendar quarter seventy-two (72) months following NERC Board of Trustees' adoption of PRC-005-6, or as otherwise made effective pursuant to the laws applicable to such ERO governmental authorities.
 - The entity shall be 100% compliant on the first day of the first calendar quarter eighty-four (84) months following applicable regulatory approval of PRC-005-6 or, in those jurisdictions where no regulatory approval is required, on the first day of the first calendar quarter ninety-six (96) months following NERC Board of Trustees' adoption of PRC-005-6 or as otherwise made effective pursuant to the laws applicable to such ERO governmental authorities.
2. For Automatic Reclosing Components, Sudden Pressure Relaying Components, and Dispersed Generation Resources maintenance activities, with maximum allowable intervals of twelve (12) calendar years, as established in Table 4-1, 4.2(a), 4.2(b), 4-3, and 5:
 - The entity shall be at least 30% compliant on the first day of the first calendar quarter sixty (60) months following applicable regulatory approval of PRC-005-6 or, in those jurisdictions where no regulatory approval is required, on the first day of the first calendar quarter seventy-two (72) months following NERC Board of Trustees' adoption of PRC-005-6 or as otherwise made effective pursuant to the laws applicable to such ERO governmental authorities.
 - The entity shall be at least 60% compliant on the first day of the first calendar quarter following one hundred eight (108) months following applicable regulatory approval of PRC-005-6 or, in those jurisdictions where no regulatory approval is required, on the first day of the first calendar quarter one hundred twenty (120) months following NERC Board of Trustees' adoption of PRC-005-6 or as otherwise made effective pursuant to the laws applicable to such ERO governmental authorities.
 - The entity shall be 100% compliant on the first day of the first calendar quarter one hundred fifty-six (156) months following applicable regulatory approval of PRC-005-6 or, in those

jurisdictions where no regulatory approval is required, on the first day of the first calendar quarter one hundred sixty-eight (168) months following NERC Board of Trustees' adoption of PRC-005-6 or as otherwise made effective pursuant to the laws applicable to such ERO governmental authorities.

Applicability:

This standard applies to the following functional entities:

- Transmission Owner
- Generator Owner
- Distribution Provider

Implementation Plan

Project 2007-17.4 PRC-005 FERC Order No. 803 Directive
PRC-005-6

Standards Involved

Approval:

- PRC-005-6 – Protection System, Automatic Reclosing, and Sudden Pressure Relaying Maintenance

Retirement:

- PRC-005-5 – Protection System, Automatic Reclosing, and Sudden Pressure Relaying Maintenance
- PRC-005-4 Protection System, Automatic Reclosing, and Sudden Pressure Relaying Maintenance
- PRC-005-3 (ii) Protection System and Automatic Reclosing Maintenance
- PRC-005-3 (i) Protection System and Automatic Reclosing Maintenance
- PRC-005-3 Protection System and Automatic Reclosing Maintenance
- PRC-005-2 (ii) Protection System Maintenance
- PRC-005-2 (i) Protection System Maintenance
- PRC-005-2 Protection System Maintenance
- PRC-005-1b – Transmission and Generation Protection System Maintenance and Testing
- PRC-008-0 – Implementation and Documentation of Underfrequency Load Shedding Equipment Maintenance Program
- PRC-011-0 – Undervoltage Load Shedding System Maintenance and Testing
- PRC-017-0 – Special Protection System Maintenance and Testing

Prerequisite Approvals:

N/A

Background:

In Order No. 803, FERC approved Standard PRC-005-3 and, in Paragraph 31, directed NERC to:

"...develop modifications to PRC-005-3 to include supervisory devices associated with auto-reclosing relay schemes to which the Reliability Standard applies. Further, we clarify that NERC's proposal regarding the scope of supervisory devices is an acceptable approach to satisfy the Commission directive. Specifically, NERC proposed in its NOPR comments, and we find acceptable, that the scope of the supervisory devices to be encompassed in the Reliability Standard are those providing voltage supervision, supervisory inputs associated with selective auto-reclosing, and sync-check relays that are part of a reclosing scheme covered by PRC-005-3."

This Implementation Plan adds:

- The implementation of changes relating to maintenance and testing of supervisory relays and associated voltage sensing devices related to Automatic Reclosing.
- The phased implementation approach included in the approved PRC-005-2 and proposed PRC-005-2(i) will remain as-is.
- This implementation schedule lays out the implementation timeline for the currently effective PRC-005-2 and proposed PRC-005-2(i), and combines the implementation plans for the approved PRC-005-3 and all subsequent pending PRC-005 versions (PRC-005-2(ii), PRC-005-3(i), PRC-005-3(ii), PRC-005-4 and PRC-005-5), making all versions from PRC-005-3 onwards effective on the same day PRC-005-6 becomes effective. The effective dates for the various phases specified in PRC-005-3 and each subsequent version of PRC-005 will align with the effective dates for those phases included in the PRC-005-6 Implementation Plan. For the pending versions that do not entail phased implementation, the versions will become effective on the date PRC-005-6 first becomes effective.
- Notwithstanding any order to the contrary, PRC-005-2(ii), PRC-005-3, PRC-005-3(i), PRC-005-3(ii), PRC-005-4 and PRC-005-5 will not become effective, and PRC-005-2 will remain in effect and not be retired until the effective date of the PRC-005-6 standard under this implementation plan.¹

The Implementation Plan reflects consideration of the following:

1. The requirements set forth in the proposed standard, which carry forward requirements from PRC-005-2, PRC-005-2(i), PRC-005-2(ii), PRC-005-3, PRC-005-3(i), PRC-005-3(ii), PRC-005-4 and PRC-005-5, establish minimum maintenance activities for Protection System, Automatic Reclosing, and Sudden Pressure Relaying Component Types as well as the maximum allowable maintenance intervals for these maintenance activities.

¹ In jurisdictions where previous versions of PRC-005 have not yet become effective according to their implementation plans (even if approved by order), this implementation plan and the PRC-005-6 standard supersedes and replaces the implementation plans and standards for PRC-005-2(i), PRC-005-2(ii), PRC-005-3, PRC-005-3(i), PRC-005-3(ii), PRC-005-4, and PRC-005-5.

2. The maintenance activities established in the various PRC-005 versions may not be presently performed by some registered entities and the established maximum allowable intervals may be shorter than those currently in use by some entities. Therefore, registered entities may not be presently performing a maintenance activity or may be using longer intervals than the maximum allowable intervals established in the PRC-005 standards. For these registered entities, it is unrealistic to become immediately compliant with the new activities or intervals. Further, registered entities should be allowed to become compliant in such a way as to facilitate a continuing PRC-005 maintenance program. The registered entities that have previously been performing maintenance within the newly specified intervals may not have all the documentation needed to demonstrate compliance with all of the maintenance activities specified.
3. The implementation schedule set forth below carries forward the implementation schedules contained in PRC-005-2 and proposed PRC-005-2(i), and combines the implementation schedules for PRC-005-2(ii), PRC-005-3, PRC-005-3(i), PRC-005-3(ii), PRC-005-4 and PRC-005-5. In addition, the implementation schedule includes changes needed to address the addition of Automatic Reclosing supervisory relays and associated voltage sensing devices in PRC-005-6.

General Considerations:

Each Transmission Owner, Generator Owner, and Distribution Provider shall maintain documentation to demonstrate compliance with PRC-005-1b, PRC-008-0, PRC-011-0, and PRC-017-0 until that entity meets all of the requirements of the effective PRC-005-2, or its combined successor standards, in accordance with this ~~implementation plan~~.

While registered entities are implementing the requirements of PRC-005-2 or its combined successor standards, each registered entity must be prepared to identify:

- All of its applicable Protection System, Automatic Reclosing, and Sudden Pressure Relaying Components, and
- Whether each component has last been maintained according to PRC-005-2 (or its combined successor standards), PRC-005-1b, PRC-008-0, PRC-011-0, PRC-017-0, or a combination thereof.

Effective Date

PRC-005-6 shall become effective on the first day of the first calendar quarter after the date that the standard is approved by an applicable governmental authority or as otherwise provided for in a jurisdiction where approval by an applicable governmental authority is required for a standard to go into effect. Where approval by an applicable governmental authority is not required, the standard shall become effective on the first day of the first calendar quarter after the date the standard is adopted by the NERC Board of Trustees or as otherwise provided for in that jurisdiction.

Retirement of Existing Standards:

Standards PRC-005-1b, PRC-008-0, PRC-011-0, and PRC-017-0 shall remain active throughout the phased implementation period of PRC-005-2 and shall be applicable to a registered entity's Protection System Component maintenance activities not yet transitioned to PRC-005-2. Standards PRC-005-1b, PRC-008-0, PRC-011-0, and PRC-017-0 shall be retired at midnight of March 31, 2027 or as otherwise made effective pursuant to the laws applicable to such Electric Reliability Organization (ERO) governmental authorities; or, in those jurisdictions where no regulatory approval is required, at midnight of March 31, 2027.

PRC-005-2 and PRC-005-2(i) shall be retired at midnight of the day immediately prior to the first day of the first calendar quarter, twelve (12) calendar months following applicable regulatory approval of PRC-005-6, or as otherwise made effective pursuant to the laws applicable to such ERO governmental authorities; or, in those jurisdictions where no regulatory approval is required, the first day of the first calendar quarter from the date of Board of Trustees' adoption.

If approved by FERC prior to the approval of PRC-005-6, PRC-005-2(ii), PRC-005-3, PRC-005-3(i), PRC-005-3(ii), PRC-005-4 and PRC-005-5 shall be retired on the date immediately prior to the first day of the first calendar quarter following regulatory approval of PRC-005-6.

Implementation Plan for Definitions:

This section includes all newly defined or revised terms used in the proposed standard. Terms already defined in the Reliability Standards Glossary of Terms (Glossary) are not repeated here. New or revised definitions listed below become approved when the proposed standard is approved by applicable governmental authority or as otherwise provided for in a jurisdiction where approval by an applicable governmental authority is required for a standard to go into effect. When the standard becomes effective, the Glossary definition will be removed from the individual standard and added to the Glossary. The definitions of terms used only in the standard will remain in the standard.

Glossary Definition:

- None

Definitions of Terms Used in the Standard:

Automatic Reclosing – Includes the following Components:

- Reclosing relay
- Supervisory relay(s) or function(s) – relay(s) or function(s) that perform voltage and/or sync check functions that enable or disable operation of the reclosing relay
- Voltage sensing devices associated with the supervisory relay(s)
- Control circuitry associated with the reclosing relay or supervisory relay(s)

Component Type –

- Any one of the five specific elements of a Protection System.
- Any one of the ~~two~~four specific elements of Automatic Reclosing.
- Any one of the two specific elements of Sudden Pressure Relaying.

Component – Any individual discrete piece of equipment included in a Protection System, Automatic Reclosing, or Sudden Pressure Relaying.

Countable Event – A failure of a Component requiring repair or replacement, any condition discovered during the maintenance activities in Tables 1-1 through 1-5, Table 3, Tables 4-1 through 4-3, and Table 5, which requires corrective action or a Protection System Misoperation attributed to hardware failure or calibration failure. Misoperations due to product design errors, software errors, relay settings different from specified settings, Protection System Component, Automatic Reclosing, or Sudden Pressure Relaying configuration or application errors are not included in Countable Events.

Implementation Plan for New or Revised Definitions:

The revised definitions (Automatic Reclosing, Component, and Countable Event) become effective upon the effective date of PRC-005-6.

Implementation Plan for PRC-005-2 and PRC-005-6

All Components with existing requirements under PRC-005-2 and PRC-005-2(i) will continue to follow the PRC-005-2 implementation plan. Those Components and/or Facilities newly introduced by PRC-005-2(ii), PRC-005-3, PRC-005-3(i), PRC-005-3(ii), PRC-005-4, PRC-005-5 and PRC-005-6 (including Sudden Pressure Relaying, Automatic Reclosing Components, and Dispersed Generation Resources) will be covered by the following Implementation Plan:

Requirements R1, R2, and R5:

~~**PRC-005-2:** For Protection System Components, entities shall be 100% compliant on April 1, 2015 or, in those jurisdictions where no regulatory approval is required, on January 1, 2015 or as otherwise made effective pursuant to the laws applicable to such ERO governmental authorities.~~

PRC-005-6: For Automatic Reclosing Components, Sudden Pressure Relaying Components, and Dispersed Generation Resources, entities shall be 100% compliant on the first day of the first calendar quarter twelve (12) months following applicable regulatory approvals of PRC-005-6 or, in those jurisdictions where no regulatory approval is required, on the first day of the first calendar quarter

twenty-four (24) months following NERC Board of Trustees' adoption of PRC-005-6 or as otherwise made effective pursuant to the laws applicable to such ERO governmental authorities.

Implementation Plan for Requirements R3 and R4:

~~PRC-005-2:~~

- ~~1. For Protection System Component maintenance activities with maximum allowable intervals of less than one (1) calendar year, as established in Tables 1-1 through 1-5:

 - ~~The entity shall be 100% compliant on October 1, 2015, or in those jurisdictions where no regulatory approval is required, on July 1, 2016, or as otherwise made effective pursuant to the laws applicable to such ERO governmental authorities.~~~~
- ~~2. For Protection System Component maintenance activities with maximum allowable intervals one (1) calendar year or more, but two (2) calendar years or less, as established in Tables 1-1 through 1-5:

 - ~~The entity shall be 100% compliant on April 1, 2017 or, in those jurisdictions where no regulatory approval is required, on January 1, 2017 or as otherwise made effective pursuant to the laws applicable to such ERO governmental authorities.~~~~
- ~~3. For Protection System Component maintenance activities with maximum allowable intervals of three (3) calendar years, as established in Tables 1-1 through 1-5:

 - ~~The entity shall be at least 30% compliant on April 1, 2016 (or, for generating plants with scheduled outage intervals exceeding two years, at the conclusion of the first succeeding maintenance outage) or, in those jurisdictions where no regulatory approval is required, on January 1, 2016 or as otherwise made effective pursuant to the laws applicable to such ERO governmental authorities.~~
 - ~~The entity shall be at least 60% compliant on April 1, 2017 or, in those jurisdictions where no regulatory approval is required, on January 1, 2017 or as otherwise made effective pursuant to the laws applicable to such ERO governmental authorities.~~
 - ~~The entity shall be 100% compliant on April 1, 2018 or, in those jurisdictions where no regulatory approval is required, on January 1, 2018 or as otherwise made effective pursuant to the laws applicable to such ERO governmental authorities.~~~~
- ~~4. For Protection System Component maintenance activities with maximum allowable intervals of six (6) calendar years, as established in Tables 1-1 through 1-5 and Table 3:

 - ~~The entity shall be at least 30% compliant on April 1, 2017 (or, for generating plants with scheduled outage intervals exceeding three years, at the conclusion of the first succeeding maintenance outage) or, in those jurisdictions where no regulatory approval is required, on January 1, 2017 or as otherwise made effective pursuant to the laws applicable to such ERO governmental authorities.~~~~

- ~~• The entity shall be at least 60% compliant on April 1, 2019 or, in those jurisdictions where no regulatory approval is required, on January 1, 2019 or as otherwise made effective pursuant to the laws applicable to such ERO governmental authorities.~~
- ~~• The entity shall be 100% compliant on April 1, 2021 or, in those jurisdictions where no regulatory approval is required, on January 1, 2021 or as otherwise made effective pursuant to the laws applicable to such ERO governmental authorities.~~

~~5. For Protection System Component maintenance activities with maximum allowable intervals of twelve (12) calendar years, as established in Tables 1-1 through 1-5, Table 2, and Table 3:~~

- ~~• The entity shall be at least 30% compliant on April 1, 2019 or, in those jurisdictions where no regulatory approval is required, on January 1, 2019 or as otherwise made effective pursuant to the laws applicable to such ERO governmental authorities.~~
- ~~• The entity shall be at least 60% compliant on April 1, 2023 or, in those jurisdictions where no regulatory approval is required, on January 1, 2023 or as otherwise made effective pursuant to the laws applicable to such ERO governmental authorities.~~
- ~~• The entity shall be 100% compliant on April 1, 2027 or, in those jurisdictions where no regulatory approval is required, on January 1, 2027 or as otherwise made effective pursuant to the laws applicable to such ERO governmental authorities.~~

PRC-005-6:

1. For Automatic Reclosing Components, Sudden Pressure Relaying Components, and Dispersed Generation Resources maintenance activities with maximum allowable intervals of six (6) calendar years, as established in Tables 4-1, 4-2(a), and 4-2(b), 4-3, and 5:
 - The entity shall be at least 30% compliant on the first day of the first calendar quarter thirty-six (36) months following applicable regulatory approval of PRC-005-6 (or, for generating plants with scheduled outage intervals exceeding three years, at the conclusion of the first succeeding maintenance outage) or, in those jurisdictions where no regulatory approval is required, on the first day of the first calendar quarter forty-eight (48) months following NERC Board of Trustees' adoption of PRC-005-6 or as otherwise made effective pursuant to the laws applicable to such ERO governmental authorities.
 - The entity shall be at least 60% compliant on the first day of the first calendar quarter sixty (60) months following applicable regulatory approval of PRC-005-6 or, in those jurisdictions where no regulatory approval is required, on the first day of the first calendar quarter seventy-two (72) months following NERC Board of Trustees' adoption of PRC-005-6, or as otherwise made effective pursuant to the laws applicable to such ERO governmental authorities.
 - The entity shall be 100% compliant on the first day of the first calendar quarter eighty-four (84) months following applicable regulatory approval of PRC-005-6 or, in those jurisdictions where no regulatory approval is required, on the first day of the first calendar quarter ninety-six (96)

months following NERC Board of Trustees' adoption of PRC-005-6 or as otherwise made effective pursuant to the laws applicable to such ERO governmental authorities.

2. For Automatic Reclosing Components, Sudden Pressure Relaying Components, and Dispersed Generation Resources maintenance activities, with maximum allowable intervals of twelve (12) calendar years, as established in Table 4-1, 4.2(a), ~~or 4.2(b)~~, 4-3, and 5:

- The entity shall be at least 30% compliant on the first day of the first calendar quarter sixty (60) months following applicable regulatory approval of PRC-005-6 or, in those jurisdictions where no regulatory approval is required, on the first day of the first calendar quarter seventy-two (72) months following NERC Board of Trustees' adoption of PRC-005-6 or as otherwise made effective pursuant to the laws applicable to such ERO governmental authorities.
- The entity shall be at least 60% compliant on the first day of the first calendar quarter following one hundred eight (108) months following applicable regulatory approval of PRC-005-6 or, in those jurisdictions where no regulatory approval is required, on the first day of the first calendar quarter one hundred twenty (120) months following NERC Board of Trustees' adoption of PRC-005-6 or as otherwise made effective pursuant to the laws applicable to such ERO governmental authorities.
- The entity shall be 100% compliant on the first day of the first calendar quarter one hundred fifty-six (156) months following applicable regulatory approval of PRC-005-6 or, in those jurisdictions where no regulatory approval is required, on the first day of the first calendar quarter one hundred sixty-eight (168) months following NERC Board of Trustees' adoption of PRC-005-6 or as otherwise made effective pursuant to the laws applicable to such ERO governmental authorities.

Applicability:

This standard applies to the following functional entities:

- Transmission Owner
- Generator Owner
- Distribution Provider

Alignment of PRC-005 Compliance Dates

I. PRC-005 Compliance Issue and Proposal to Align Compliance Dates

Since the approval of PRC-005-2, which is currently mandatory and enforceable, a number of standards development projects have resulted in either including or excluding devices from the scope of PRC-005. Currently, there are eight approved or currently proposed PRC-005 versions, and each Version comes with a separate implementation schedule. Depending on the type of device and specific requirement in some of the PRC-005 versions, the implementation is divided into phases, requiring registered entities to gradually ensure compliance of a percentage of their devices until they reach 100% compliance.

Versions -3, -4, and -6 will require three consecutive updates to the registered entities' Protection System Maintenance Programs (PSMP), which is expected to be a time-consuming task for many entities. Based on the implementation plans for these three versions, the required PSMP updates would have to be completed within one (1) year to eighteen (18) months. According to the PRC-005 drafting team, which represents various industry members, this short period of time for review and identification of all assets subject to the revised PRC-005 versions could lead to errors and misidentification of devices. Further, the existence of eight implementation plans could lead to misinterpretations and inconsistencies in the compliance and auditing practices throughout the Electric Reliability Organization (ERO) Enterprise.

To address this compliance issue, the PRC-005 drafting team requested that NERC align the effective dates of all outstanding PRC-005 Versions, thus simplifying the implementation schedule for this Reliability Standard. In response to the drafting team's request, NERC plans to petition the Federal Energy Regulatory Commission (FERC) to delay the implementation of PRC-005-3 and have PRC-005-2(ii), PRC-005-3, PRC-005-3(i), PRC-005-3(ii), PRC-005-4, PRC-005-5, and PRC-005-6 all become effective on the same date. NERC is also proposing that the implementation of PRC-005-2(i) is aligned with the currently effective PRC-005-2. The phased implementation approach will remain but the effective dates for each phase will align across all applicable versions.

This proposal is reflected in the implementation plan for PRC-005-6. If supported by industry members, the implementation plan will be included in the PRC-005-6 petition to be filed with FERC for review.

II. PRC-005 Versions Overview

The draft PRC-005-6 incorporates all revisions made to PRC-005-2 as a result of the development of PRC-005-2(i), PRC-005-2(ii), PRC-005-3, PRC-005-3(i), PRC-005-3(ii), PRC-005-4, and PRC-005-5, and PRC-005-6. Version 3 added Automatic Reclosing devices; versions 2(i), 3(i), and -5 exclude individual dispersed generation resources from the applicability of the standard; versions 2(ii) and 3(ii) replace the term "Special Protection System" with the term "Remedial Action Scheme"; version 4 added Sudden Pressure Relays; and version 6 will add supervisory relays and exclude individual dispersed generation resources from the applicability of this Reliability Standard.

From this list of all PRC-005 versions, version 3 is approved by FERC; PRC-005-2(i), PRC-005-2(ii), PRC-005-3(i), PRC-005-3(ii), and PRC-005-4 are pending regulatory approval; PRC-005-5 has not yet been filed for approval with FERC; and PRC-005-6 is currently under development.

III. Impact on the Reliability of the Bulk Power System and on Compliance with PRC-005

Based on the implementation schedule for the FERC-approved PRC-005-3 and estimated approval and effective dates for the remaining versions, the delay in the implementation of PRC-005-3 created by this proposal is anticipated to be approximately one year.

The proposed changes described here and in the proposed PRC-005-6 implementation plan will not affect the immediate implementation of versions 2(i), 3(i), and -5. These versions exclude certain dispersed generation resources from the definition of Bulk Electric System, and from the applicability of PRC-005. Thus, registered entities that own and operate dispersed generation resources will remain unaffected by the proposed changes.

PRC-005-2(ii) and PRC-005-3(ii) reflect enhancements to the NERC Glossary of Terms related to Special Protection Systems and Remedial Action Schemes. While alignment between the standards and the Glossary of Terms is important, potential delays in this alignment would not present a risk to the reliability of the Bulk Power System (BPS). The petition requesting changes to PRC-005-2(ii) and PRC-005-3(ii) is pending and its review will likely be delayed until the Commission reviews the petition for PRC-010-1 related to Under-Voltage Load Shedding Program. Finally, the anticipated changes related to Remedial Action Schemes are minor in nature and are unlikely to introduce an actual reliability risk.

Because the Automatic Reclosing devices and Sudden Pressure Relays brought in by versions -3 and -4 are limited in scope, a potential delay in the implementation of these versions of PRC-005 is also unlikely to increase risk to the BPS. Many of these devices are already monitored by industry in anticipation of the upcoming compliance requirements, but may not be specifically included in the registered entities' PSMPs at this time.

IV. Benefits to Registered Entities

The proposal aims to simplify the compliance efforts of all registered entities subject to PRC-005 and give industry additional time to comply with versions -3, -4, and -6, which require PSMP updates. Having PRC-005-2(ii), PRC-005-3, PRC-005-3(i), PRC-005-3(ii), PRC-005-4, and PRC-005-5, PRC-005-6 become effective at the same time minimizes the possibility of misinterpretations of each version and associated compliance obligations, thus limiting the compliance risk for registered entities. In addition, the proposed changes will not affect the anticipated exclusion of certain dispersed generation resources from the scope of the standard.

To further facilitate compliance, NERC plans to use the additional time until PRC-005-6 becomes effective to conduct outreach and provide training to ensure that registered entities are well aware and prepared to meet their obligations under the various PRC-005 versions.

Effective Date Information

Table 1 provides information regarding each version of the PRC-005 standard.

Table 1: PRC-005 Effective Date Information		
Standard	Effective Date ¹	Comments
PRC-005-2	April 1, 2015	
PRC-005-2(i)	May 29, 2015	Proposed effective date with version 2, which will be immediately following FERC Approval.
PRC-005-2(ii)	Filed and Pending Regulatory Approval	Proposed to be deferred until version 6 effective date. ²
PRC-005-3	April 1, 2016	Proposed to be deferred until version 6 effective date.
PRC-005-3(i)	April 1, 2016	Proposed to be deferred until version 6 effective date.
PRC-005-3(ii)	Filed and Pending Regulatory Approval	Proposed to be deferred until version 6 effective date.
PRC-005-4	Filed and Pending Regulatory Approval	Proposed to be deferred until version 6 effective date.
PRC-005-5	Pending Regulatory Filing	Proposed to be deferred until version 6 effective date.
PRC-005-6	Pending Regulatory Filing	TBD

¹ The effective date listed is the start date of when the standard becomes effective. This does not include the phased in approach.

² The effective date is dependent on when FERC approves PRC-005-6, which could be from three (3) months to one (1) year.

Unofficial Comment Form

Project 2007-17.4 PRC-005 Order No. 803 Directive PRC-005-6

DO NOT use this form for submitting comments. Use the [electronic form](#) to submit comments on **PRC-005-6 – Protection System, Automatic Reclosing, and Sudden Pressure Relaying Maintenance** Reliability Standard. The electronic form must be submitted by **8:00 p.m. Eastern, Wednesday, September 16, 2015**.

Documents and information about this project are available on the [project page](#). If you have questions contact Senior Standards Developer, [Stephen Crutchfield](#) (via email) or at (609) 651-9455.

Background Information

In Order No. 803, FERC approved Standard PRC-005-3 and, in Paragraph 31, directed NERC to:

"...direct that, pursuant to section 215(d)(5) of the FPA, NERC develop modifications to PRC-005-3 to include supervisory devices associated with auto-reclosing relay schemes to which the Reliability Standard applies. Further, we clarify that NERC's proposal regarding the scope of supervisory devices is an acceptable approach to satisfy the Commission directive. Specifically, NERC proposed in its NOPR comments, and we find acceptable, that the scope of the supervisory devices to be encompassed in the Reliability Standard are those providing voltage supervision, supervisory inputs associated with selective auto-reclosing, and sync-check relays that are part of a reclosing scheme covered by PRC-005-3."

The Protection System Maintenance and Testing Standard Drafting Team (PSMTSDT) posted a revised Standard Authorization Request (SAR) and associated documents June 11 – July 10, 2015. Based on comments received during this posting, the PSMTSDT made the following revisions:

- Remove Balancing Authority as an applicable entity under the SAR.
- Removed reference to PRC-005-2(i) from the SAR since it has already been approved by FERC.
- Revised the second bullet of the definition of "Automatic Reclosing" to include "function(s)" as shown above.
- Added a note to Tables 4-2a, 4-2b and 4-3 of PRC-005-6 similar to that on Table 5: "Note: In cases where Components of Sudden Pressure Relaying are common to Components listed in Table 1-5, the Components only need to be tested once during a distinct maintenance interval."
- Made revisions to the Implementation Plan to consolidate the language regarding the implementation of PRC-005-2.

- Corrected typographical errors in the Supplementary Reference and FAQ document as well as other minor revisions.
- Removed recently added language on page 26 of the Supplementary Reference and AFQ document regarding R1, Part 1.2.

The Protection System Maintenance and Testing Standard Drafting Team (PSMTSDT) proposed revision of the standard specific defined terms “Automatic Reclosing” and “Component Type” as follows:

Automatic Reclosing – Includes the following Components:

- Reclosing relay
- **Supervisory relay(s) or function(s) – relay(s) or function(s) that perform voltage and/or sync check functions that enables or disables operation of the reclosing relay**
- **Voltage sensing devices associated with the supervisory relay(s)**
- Control circuitry associated with the reclosing relay **or supervisory relay(s)**

Component Type –

- Any one of the five specific elements of a Protection System.
- Any one of the ~~two~~**four** specific elements of Automatic Reclosing.
- Any one of the two specific elements of Sudden Pressure Relaying.

The Rationales for “Automatic Relaying” and “Component Type” were also revised to reflect the proposed revisions to the defined terms above. Tables 4-1 and 4-2 were updated by adding “supervisory relay(s)” as appropriate. A new Table 4-3 was added to address maintenance activities and intervals for Automatic Reclosing with supervisory relays. No substantive revisions are being proposed for the Requirements of the standard. The only revisions to Requirements R1 and R3 included updating the Table numbering to reflect the addition of Table 4-3. The VSLs were updated to reflect the Requirement language for R1 and R3. All references to table numbering throughout the standard have also been corrected to reflect the addition of Table 4-3. This version of PRC-005 used PRC-005-5 developed under Project 2014-01 as the starting point for revisions to address the directive.

The PSMTSDT has proposed combining the Implementation Plans for previous versions of PRC-005 (including PRC-005-3, PRC-005-3i, PRC-005-3ii, PRC-005-4 and PRC-005-5). The team believes that the proposed Implementation Plan for PRC-005-6 alleviates the burden of multiple revisions of the Protection System Maintenance Program (PSMP) by aligning the effective dates of all of these version of PRC-005 while minimizing risk to the Bulk Electric System.

The PSMTSDT posted a revised SAR and associated documents June 11 – July 10, 2015. Based on comments received during this posting, the PSMTSDT made the following revisions:

- Remove Balancing Authority as an applicable entity under the SAR.
- Removed reference to PRC-005-2(i) from the SAR since it has already been approved by FERC.
- Revised the second bullet of the definition of “Automatic Reclosing” to include “function(s)” as shown above.
- Added a note to Tables 4-2a, 4-2b and 4-3 of PRC-005-6 similar to that on Table 5: “Note: In cases where Components of Sudden Pressure Relaying are common to Components listed in Table 1-5, the Components only need to be tested once during a distinct maintenance interval.”
- Made revisions to the Implementation Plan to consolidate the language regarding the implementation of PRC-005-2.
- Corrected typographical errors in the Supplementary Reference and FAQ document as well as other minor revisions.

Due to the expected volume of comments, the PSMTSDT asks that commenters consider consolidating responses and endorsing comments provided by another.

Questions

1. The PSMTSDT has proposed revising the definition of “Automatic Reclosing” and “Component Type” to address the FERC directive in Order 803. Do you agree that the proposed revised definitions? If not, please provide specific comments regarding the revision and any suggestions for alternatives to address the directive.

Yes

No

Comments:

2. The PSMTSDT has added Table 4-3 to address maintenance activities and intervals for voltage sensing devices associated with supervisory relays. Do you agree with the proposed table? If not, please provide specific comments regarding the table and any suggestions for alternative language.

Yes

No

Comments:

3. The PSMTSDT has made revisions to the Supplementary Reference and FAQ Document. Do you agree with the proposed revisions? If not, please provide specific comments regarding the revisions and any suggestions for alternative language.

- Yes
- No

Comments:

4. The PSMTSDT has proposed combining the Implementation Plans for previous versions of PRC-005 (including PRC-005-3, PRC-005-3i, PRC-005-3ii, PRC-005-4 and PRC-005-5). Do you agree with the proposed Implementation Plan? If not, please provide specific comments regarding the Implementation Plan and any suggestions for alternative language.

- Yes
- No

Comments:

Standards Authorization Request Form

When completed, email this form to:

Howard.Gugel@nerc.net

For questions about this form or for assistance in completing the form, call Valerie Agnew at 404-446-9693.

NERC welcomes suggestions for improving the reliability of the Bulk-Power System through improved Reliability Standards. Please use this form to submit your proposal for a new NERC Reliability Standard or a revision to an existing standard.

Request to propose a new or a revision to a Reliability Standard

Proposed Standard:	PRC-005-6		
Date Submitted:	May 21, 2015		
SAR Requester Information			
Name:	Charles Rogers		
Organization:	Protection System Maintenance Standard Drafting Team		
Telephone:	517-788-0027	E-mail:	Charles.Rogers@cmsenergy.com
SAR Type (Check as many as applicable)			
<input type="checkbox"/>	New Standard	<input type="checkbox"/>	Withdrawal of existing Standard
<input checked="" type="checkbox"/>	Revision to existing Standard	<input type="checkbox"/>	Urgent Action

Standards Authorization Request Form

SAR Information
Industry Need (What is the industry problem this request is trying to solve?):
In Order No. 803, FERC approved Standard PRC-005-3 and, in Paragraph 31, directed that: "...pursuant to section 215(d)(5) of the FPA, NERC develop modifications to PRC-005-3 to include supervisory devices associated with auto-reclosing relay schemes to which the Reliability Standard applies. Further, we clarify that NERC’s proposal regarding the scope of supervisory devices is an acceptable approach to satisfy the Commission directive. Specifically, NERC proposed in its NOPR comments, and we find acceptable, that the scope of the supervisory devices to be encompassed in the Reliability Standard are those providing voltage supervision, supervisory inputs associated with selective auto-reclosing, and sync-check relays that are part of a reclosing scheme covered by PRC-005-3."

SAR Information
Purpose or Goal (How does this request propose to address the problem described above?):
The Standard Drafting Team (SDT) shall consider modifications, as needed, to address the FERC directive contained in Order 803 resulting from the Commission’s consideration of PRC-005-3. The Supplementary Reference Document (provided as a technical reference for PRC-005-3) should also be modified to provide the rationale for the maintenance activities and intervals within the revised standard, as well as to provide application guidance to industry.
Identify the Objectives of the proposed standard’s requirements (What specific reliability deliverables are required to achieve the goal?):
Provide clear, unambiguous requirements, standard specific definitions, and advisory guidance to address the directives in FERC Order 803.
Brief Description (Provide a paragraph that describes the scope of this standard action.)
The SDT shall modify NERC Standard PRC-005-3 to explicitly address the directive in Order 803. The SDT shall also consider changes to the standard and supporting documents that provide consistency and alignment with other Reliability Standards.

Standards Authorization Request Form

SAR Information

Detailed Description (Provide a description of the proposed project with sufficient details for the standard drafting team to execute the SAR. Also provide a justification for the development or revision of the standard, including an assessment of the reliability and market interface impacts of implementing or not implementing the standard action.)

The SDTs execution of this Standard Authorization Request (SAR) requires the SDT to address the directive in FERC Order 803. The SDT will develop requirement(s) to include supervisory devices associated with automatic reclosing relay schemes to which the Reliability Standard applies. The SDT may elect to propose revisions to the standard regarding the scope of supervisory devices as an acceptable approach to satisfy the Commission directive, as proposed in the Notice of Proposed Rulemaking (NOPR) comments submitted by NERC. Specifically, NERC proposed that the scope of the supervisory devices to be encompassed in the Reliability Standard are those providing voltage supervision, supervisory inputs associated with selective automatic reclosing, and synchronism check relays that are part of a reclosing scheme covered by PRC-005-3.

The SDT shall also:

1. Revise the Implementation Plans for PRC-005-2ii, PRC-005-3, PRC-005-3i, PRC-005-3ii, PRC-005-4 and PRC-005-5 as needed to facilitate consistent and systematic implementation.
2. Modify the informative Supplementary Reference Document (provided as a technical reference for PRC-005-3) as necessary to provide application guidance to industry.

Reliability Functions

The Standard will Apply to the Following Functions (Check each one that applies.)

<input type="checkbox"/> Regional Reliability Organization	Conducts the regional activities related to planning and operations, and coordinates activities of Responsible Entities to secure the reliability of the Bulk Electric System within the region and adjacent regions.
<input type="checkbox"/> Reliability Coordinator	Responsible for the real-time operating reliability of its Reliability Coordinator Area in coordination with its neighboring Reliability Coordinator’s wide area view.

Standards Authorization Request Form

Reliability Functions	
<input type="checkbox"/> Balancing Authority	Integrates resource plans ahead of time, and maintains load-interchange-resource balance within a Balancing Authority Area and supports Interconnection frequency in real time.
<input type="checkbox"/> Interchange Authority	Ensures communication of interchange transactions for reliability evaluation purposes and coordinates implementation of valid and balanced interchange schedules between Balancing Authority Areas.
<input type="checkbox"/> Planning Coordinator	Assesses the longer-term reliability of its Planning Coordinator Area.
<input type="checkbox"/> Resource Planner	Develops a >one year plan for the resource adequacy of its specific loads within a Planning Coordinator area.
<input type="checkbox"/> Transmission Planner	Develops a >one year plan for the reliability of the interconnected Bulk Electric System within its portion of the Planning Coordinator area.
<input type="checkbox"/> Transmission Service Provider	Administers the transmission tariff and provides transmission services under applicable transmission service agreements (e.g., the pro forma tariff).
<input checked="" type="checkbox"/> Transmission Owner	Owns and maintains transmission facilities.
<input type="checkbox"/> Transmission Operator	Ensures the real-time operating reliability of the transmission assets within a Transmission Operator Area.
<input checked="" type="checkbox"/> Distribution Provider	Delivers electrical energy to the End-use customer.
<input checked="" type="checkbox"/> Generator Owner	Owns and maintains generation facilities.
<input type="checkbox"/> Generator Operator	Operates generation unit(s) to provide real and reactive power.
The Standard will Apply to the Following Functions (Check each one that applies.)	
<input type="checkbox"/> Purchasing-Selling Entity	Purchases or sells energy, capacity, and necessary reliability-related services as required.
<input type="checkbox"/> Market Operator	Interface point for reliability functions with commercial functions.
<input type="checkbox"/> Load-Serving Entity	Secures energy and transmission service (and reliability-related services) to serve the End-use Customer.

Standards Authorization Request Form

Reliability and Market Interface Principles	
Applicable Reliability Principles (Check all that apply).	
<input checked="" type="checkbox"/>	1. Interconnected bulk power systems shall be planned and operated in a coordinated manner to perform reliably under normal and abnormal conditions as defined in the NERC Standards.
<input type="checkbox"/>	2. The frequency and voltage of interconnected bulk power systems shall be controlled within defined limits through the balancing of real and reactive power supply and demand.
<input type="checkbox"/>	3. Information necessary for the planning and operation of interconnected bulk power systems shall be made available to those entities responsible for planning and operating the systems reliably.
<input type="checkbox"/>	4. Plans for emergency operation and system restoration of interconnected bulk power systems shall be developed, coordinated, maintained and implemented.
<input checked="" type="checkbox"/>	5. Facilities for communication, monitoring and control shall be provided, used and maintained for the reliability of interconnected bulk power systems.
<input type="checkbox"/>	6. Personnel responsible for planning and operating interconnected bulk power systems shall be trained, qualified, and have the responsibility and authority to implement actions.
<input type="checkbox"/>	7. The security of the interconnected bulk power systems shall be assessed, monitored and maintained on a wide area basis.
<input type="checkbox"/>	8. Bulk power systems shall be protected from malicious physical or cyber attacks.
Does the proposed Standard comply with all of the following Market Interface Principles?	
1. A reliability standard shall not give any market participant an unfair competitive advantage.	Enter (yes/no) Yes
2. A reliability standard shall neither mandate nor prohibit any specific market structure.	Yes
Does the proposed Standard comply with all of the following Market Interface Principles?	
3. A reliability standard shall not preclude market solutions to achieving compliance with that standard.	Enter (yes/no) Yes
4. A reliability standard shall not require the public disclosure of commercially sensitive information. All market participants shall have equal opportunity to access commercially non-sensitive information that is required for compliance with reliability standards.	Yes

Standards Authorization Request Form

Related Standards	
Standard No.	Explanation

Related SARs	
SAR ID	Explanation

Standards Authorization Request Form

Regional Variances	
Region	Explanation
ERCOT	
FRCC	
MRO	
NPCC	
RFC	
SERC	
SPP	
WECC	

Standards Authorization Request Form

When completed, email this form to:

Howard.Gugel@nerc.net / Valerie.Agnew@nerc.net

For questions about this form or for assistance in completing the form, call [Howard Gugel](tel:404-446-2566) / [Valerie Agnew](tel:404-446-2566) at 404-446-2566/9693.

NERC welcomes suggestions for improving the reliability of the Bulk-Power System through improved Reliability Standards. Please use this form to submit your proposal for a new NERC Reliability Standard or a revision to an existing standard.

Request to propose a new or a revision to a Reliability Standard

Proposed Standard:	PRC-005-6		
Date Submitted:	May 21, 2015		
SAR Requester Information			
Name:	Charles Rogers		
Organization:	Protection System Maintenance Standard Drafting Team		
Telephone:	517-788-0027	E-mail:	Charles.Rogers@cmsenergy.com
SAR Type (Check as many as applicable)			
<input type="checkbox"/> New Standard	<input type="checkbox"/> Withdrawal of existing Standard		
<input checked="" type="checkbox"/> Revision to existing Standard	<input type="checkbox"/> Urgent Action		

~~Standards Authorization Request Form~~ Standards Authorization Request Form

SAR Information
Industry Need (What is the industry problem this request is trying to solve?):
In Order No. 803, FERC approved Standard PRC-005-3 and, in Paragraph 31, directed that: "...pursuant to section 215(d)(5) of the FPA, NERC develop modifications to PRC-005-3 to include supervisory devices associated with auto-reclosing relay schemes to which the Reliability Standard applies. Further, we clarify that NERC's proposal regarding the scope of supervisory devices is an acceptable approach to satisfy the Commission directive. Specifically, NERC proposed in its NOPR comments, and we find acceptable, that the scope of the supervisory devices to be encompassed in the Reliability Standard are those providing voltage supervision, supervisory inputs associated with selective auto-reclosing, and sync-check relays that are part of a reclosing scheme covered by PRC-005-3."

SAR Information
Purpose or Goal (How does this request propose to address the problem described above?):
The <u>Standard Drafting Team (SDT)</u> shall consider modifications, as needed, to address the FERC directive contained in Order 803 resulting from the Commission's consideration of PRC-005-3. The Supplementary Reference Document (provided as a technical reference for PRC-005-3) should also be modified to provide the rationale for the maintenance activities and intervals within the revised standard, as well as to provide application guidance to industry.
Identify the Objectives of the proposed standard's requirements (What specific reliability deliverables are required to achieve the goal?):
Provide clear, unambiguous requirements, standard specific definitions standard(s) , and advisory guidance to address the directives in FERC Order 803.
Brief Description (Provide a paragraph that describes the scope of this standard action.)
The Standard Drafting Team (SDT) shall modify NERC Standard PRC-005-3 to explicitly address the directive in Order 803. The SDT shall also consider changes to the standard and supporting documents that provide consistency and alignment with other Reliability Standards.

Standards Authorization Request Form

SAR Information

Detailed Description (Provide a description of the proposed project with sufficient details for the standard drafting team to execute the SAR. Also provide a justification for the development or revision of the standard, including an assessment of the reliability and market interface impacts of implementing or not implementing the standard action.)

The SDTs execution of this [Standard Authorization Request \(SAR\)](#) requires the SDT to address the directive in FERC Order 803. The SDT will develop requirement(s) to include supervisory devices associated with automatic reclosing relay schemes to which the Reliability Standard applies. The SDT may elect to propose revisions to the standard regarding the scope of supervisory devices as an acceptable approach to satisfy the Commission directive, as proposed in the [Notice of Proposed Rulemaking \(NOPR\)](#) comments submitted by NERC. Specifically, NERC proposed that the scope of the supervisory devices to be encompassed in the Reliability Standard are those providing voltage supervision, supervisory inputs associated with selective automatic reclosing, and synchronism check relays that are part of a reclosing scheme covered by PRC-005-3.

The SDT shall also:

1. Revise the Implementation Plans for ~~PRC-002i~~, PRC-005-2ii, PRC-005-3, PRC-005-3i, PRC-005-3ii, PRC-005-4 and PRC-005-5 as needed to facilitate consistent and systematic implementation.
2. Modify the informative Supplementary Reference Document (provided as a technical reference for PRC-005-3) as necessary to provide application guidance to industry.

Reliability Functions

The Standard will Apply to the Following Functions (Check each one that applies.)

<input type="checkbox"/> Regional Reliability Organization	Conducts the regional activities related to planning and operations, and coordinates activities of Responsible Entities to secure the reliability of the Bulk Electric System within the region and adjacent regions.
<input type="checkbox"/> Reliability Coordinator	Responsible for the real-time operating reliability of its Reliability Coordinator Area in coordination with its neighboring Reliability Coordinator’s wide area view.

Reliability Functions	
<input type="checkbox"/> <input checked="" type="checkbox"/> Balancing Authority	Integrates resource plans ahead of time, and maintains load-interchange-resource balance within a Balancing Authority Area and supports Interconnection frequency in real time.
<input type="checkbox"/> Interchange Authority	Ensures communication of interchange transactions for reliability evaluation purposes and coordinates implementation of valid and balanced interchange schedules between Balancing Authority Areas.
<input type="checkbox"/> Planning Coordinator	Assesses the longer-term reliability of its Planning Coordinator Area.
<input type="checkbox"/> Resource Planner	Develops a >one year plan for the resource adequacy of its specific loads within a Planning Coordinator area.
<input type="checkbox"/> Transmission Planner	Develops a >one year plan for the reliability of the interconnected Bulk Electric System within its portion of the Planning Coordinator area.
<input type="checkbox"/> Transmission Service Provider	Administers the transmission tariff and provides transmission services under applicable transmission service agreements (e.g., the pro forma tariff).
<input checked="" type="checkbox"/> Transmission Owner	Owns and maintains transmission facilities.
<input type="checkbox"/> Transmission Operator	Ensures the real-time operating reliability of the transmission assets within a Transmission Operator Area.
<input checked="" type="checkbox"/> Distribution Provider	Delivers electrical energy to the End-use customer.
<input checked="" type="checkbox"/> Generator Owner	Owns and maintains generation facilities.
<input type="checkbox"/> Generator Operator	Operates generation unit(s) to provide real and reactive power.
The Standard will Apply to the Following Functions (Check each one that applies.)	
<input type="checkbox"/> Purchasing-Selling Entity	Purchases or sells energy, capacity, and necessary reliability-related services as required.
<input type="checkbox"/> Market Operator	Interface point for reliability functions with commercial functions.
<input type="checkbox"/> Load-Serving Entity	Secures energy and transmission service (and reliability-related services) to serve the End-use Customer.

Reliability and Market Interface Principles	
Applicable Reliability Principles (Check all that apply).	
<input checked="" type="checkbox"/>	1. Interconnected bulk power systems shall be planned and operated in a coordinated manner to perform reliably under normal and abnormal conditions as defined in the NERC Standards.
<input type="checkbox"/>	2. The frequency and voltage of interconnected bulk power systems shall be controlled within defined limits through the balancing of real and reactive power supply and demand.
<input type="checkbox"/>	3. Information necessary for the planning and operation of interconnected bulk power systems shall be made available to those entities responsible for planning and operating the systems reliably.
<input type="checkbox"/>	4. Plans for emergency operation and system restoration of interconnected bulk power systems shall be developed, coordinated, maintained and implemented.
<input checked="" type="checkbox"/>	5. Facilities for communication, monitoring and control shall be provided, used and maintained for the reliability of interconnected bulk power systems.
<input type="checkbox"/>	6. Personnel responsible for planning and operating interconnected bulk power systems shall be trained, qualified, and have the responsibility and authority to implement actions.
<input type="checkbox"/>	7. The security of the interconnected bulk power systems shall be assessed, monitored and maintained on a wide area basis.
<input type="checkbox"/>	8. Bulk power systems shall be protected from malicious physical or cyber attacks.
Does the proposed Standard comply with all of the following Market Interface Principles?	
1. A reliability standard shall not give any market participant an unfair competitive advantage.	Enter (yes/no) Yes
2. A reliability standard shall neither mandate nor prohibit any specific market structure.	Yes
Does the proposed Standard comply with all of the following Market Interface Principles?	
3. A reliability standard shall not preclude market solutions to achieving compliance with that standard.	Enter (yes/no) Yes
4. A reliability standard shall not require the public disclosure of commercially sensitive information. All market participants shall have equal opportunity to access commercially non-sensitive information that is required for compliance with reliability standards.	Yes

Standards Authorization Request Form

Related Standards	
Standard No.	Explanation

Related SARs	
SAR ID	Explanation

Regional Variances	
Region	Explanation
ERCOT	
FRCC	
MRO	
NPCC	
RFC	
SERC	
SPP	
WECC	

Violation Risk Factor and Violation Severity Level Justifications

Project 2007-17.4 PRC-005-6

Protection System, Automatic Reclosing and Sudden Pressure Relaying Maintenance

Violation Risk Factor and Violation Severity Level Justifications

This document provides the drafting team's justification for assignment of violation risk factors (VRFs) and violation severity levels (VSLs) for each requirement in PRC-005-6 - Protection System, Automatic Reclosing and Sudden Pressure Relaying Maintenance.

Each primary requirement is assigned a VRF and a set of one or more VSLs. These elements support the determination of an initial value range for the Base Penalty Amount regarding violations of requirements in FERC-approved Reliability Standards, as defined in the ERO Sanction Guidelines.

The Protection System Maintenance and Testing Standard Drafting Team (SDT) applied the following NERC criteria and FERC Guidelines when proposing VRFs and VSLs for the requirements under this project:

NERC Criteria – VRFs

High Risk Requirement

A requirement that, if violated, could directly cause or contribute to bulk electric system instability, separation, or a cascading sequence of failures, or could place the bulk electric system at an unacceptable risk of instability, separation, or cascading failures; or, a requirement in a planning time frame that, if violated, could, under emergency, abnormal, or restorative conditions anticipated by the preparations, directly cause or contribute to bulk electric system instability, separation, or a cascading sequence of failures, or could place the bulk electric system at an unacceptable risk of instability, separation, or cascading failures, or could hinder restoration to a normal condition.

Medium Risk Requirement

A requirement that, if violated, could directly affect the electrical state or the capability of the bulk electric system, or the ability to effectively monitor and control the bulk electric system. However, violation of a medium risk requirement is unlikely to lead to bulk electric system instability, separation, or cascading failures; or, a requirement in a planning time frame that, if violated, could, under emergency, abnormal, or restorative conditions anticipated by the preparations, directly and adversely affect the electrical state or capability of the bulk electric system, or the ability to effectively monitor, control, or restore the bulk electric system. However, violation of a medium risk

requirement is unlikely, under emergency, abnormal, or restoration conditions anticipated by the preparations, to lead to bulk electric system instability, separation, or cascading failures, nor to hinder restoration to a normal condition.

Lower Risk Requirement

A requirement that is administrative in nature and a requirement that, if violated, would not be expected to adversely affect the electrical state or capability of the bulk electric system, or the ability to effectively monitor and control the bulk electric system; or, a requirement that is administrative in nature and a requirement in a planning time frame that, if violated, would not, under the emergency, abnormal, or restorative conditions anticipated by the preparations, be expected to adversely affect the electrical state or capability of the bulk electric system, or the ability to effectively monitor, control, or restore the bulk electric system. A planning requirement that is administrative in nature.

FERC VRF Guidelines

Guideline (1) – Consistency with the Conclusions of the Final Blackout Report

The Commission seeks to ensure that VRFs assigned to Requirements of Reliability Standards in these identified areas appropriately reflect their historical critical impact on the reliability of the Bulk-Power System.

In the VSL Order, FERC listed critical areas (from the Final Blackout Report) where violations could severely affect the reliability of the Bulk-Power System:

- Emergency operations
- Vegetation management
- Operator personnel training
- Protection systems and their coordination
- Operating tools and backup facilities
- Reactive power and voltage control
- System modeling and data exchange
- Communication protocol and facilities
- Requirements to determine equipment ratings
- Synchronized data recorders
- Clearer criteria for operationally critical facilities
- Appropriate use of transmission loading relief

Guideline (2) – Consistency within a Reliability Standard

The Commission expects a rational connection between the sub-Requirement VRF assignments and the main Requirement VRF assignment.

Guideline (3) — Consistency among Reliability Standards

The Commission expects the assignment of VRFs corresponding to Requirements that address similar reliability goals in different Reliability Standards would be treated comparably.

Guideline (4) — Consistency with NERC’s Definition of the VRF Level

Guideline (4) was developed to evaluate whether the assignment of a particular VRF level conforms to NERC’s definition of that risk level.

Guideline (5) — Treatment of Requirements that Co-mingle More Than One Obligation

Where a single Requirement co-mingles a higher risk reliability objective and a lesser risk reliability objective, the VRF assignment for such Requirements must not be watered down to reflect the lower risk level associated with the less important objective of the Reliability Standard.

The following discussion addresses how the SDT considered FERC’s VRF Guidelines 2 through 5. The team did not address Guideline 1 directly because of an apparent conflict between Guidelines 1 and 4. Whereas Guideline 1 identifies a list of topics that encompass nearly all topics within NERC’s Reliability Standards and implies that these requirements should be assigned a “High” VRF, Guideline 4 directs assignment of VRFs based on the impact of a specific requirement to the reliability of the system. The SDT believes that Guideline 4 is reflective of the intent of VRFs in the first instance and therefore concentrated its approach on the reliability impact of the requirements.

PRC-005-6 Protection System, Automatic Reclosing and Sudden Pressure Relaying Maintenance is a revision of PRC-005-3 Protection System and Automatic Reclosing Maintenance with the stated purpose: To document and implement programs for the maintenance of all Protection Systems, Automatic Reclosing, and Sudden Pressure Relaying affecting the reliability of the Bulk Electric System (BES) so that they are kept in working order.

PRC-005-6 has five (5) requirements that address the inclusion of Sudden Pressure Relaying. A Table of minimum maintenance activities and maximum maintenance intervals for Sudden Pressure Relaying has been added to PRC-005-3 to address FERC’s directives from Order 758. The revised standard requires that entities develop an appropriate Protection System Maintenance Program (PSMP), that they implement their PSMP, and that, in the event they are unable to restore Sudden Pressure Relaying Components to proper working order while performing maintenance, they initiate the follow-up activities necessary to resolve those maintenance issues.

The requirements of PRC-005-6 map one-to-one with the requirements of PRC-005-3. The drafting team did not revise the VRFs for the requirements of PRC-005-3 in PRC-005-6.

PRC-005-6 Requirements R1 and R2 are related to developing and documenting a Protection System Maintenance Program. The SDT determined that the assignment of a VRF of Medium was consistent with the NERC criteria that violations of these requirements could directly affect the electrical state or the capability of the bulk electric system, or the ability to effectively monitor and control the bulk electric system but are unlikely to lead to bulk electric system instability, separation, or cascading failures. Additionally, a review of the body of existing NERC Standards with approved VRFs revealed

that requirements with similar reliability objectives in other standards are largely assigned a VRF of Medium.

PRC-005-6 Requirements R3 and R4 are related to implementation of the Protection System Maintenance Program. The SDT determined that the assignment of a VRF of High was consistent with the NERC criteria that that violation of these requirements could directly cause or contribute to bulk electric system instability, separation, or a cascading sequence of failures, or could place the bulk electric system at an unacceptable risk of instability, separation, or cascading failures. Additionally, a review of the body of existing NERC Standards with approved VRFs revealed that requirements with similar reliability objectives in other standards are assigned a VRF of High.

PRC-005-6 Requirement R5 relates to the initiation of actions resulting in resolution of unresolved maintenance issues, which describe situations where an entity was unable to restore a Component to proper working order during the performance of the maintenance activity. The SDT determined that the assignment of a VRF of Medium was consistent with the NERC criteria that violation of this requirements could directly affect the electrical state or the capability of the bulk electric system, or the ability to effectively monitor and control the bulk electric system but are unlikely to lead to bulk electric system instability, separation, or cascading failures. Additionally, a review of the body of existing NERC Standards with approved VRFs revealed that requirements with similar reliability objectives in other standards are largely assigned a VRF of Medium.

NERC Criteria - VSLs

VSLs define the degree to which compliance with a requirement was not achieved. Each requirement must have at least one VSL. While it is preferable to have four VSLs for each requirement, some requirements do not have multiple “degrees” of noncompliant performance and may have only one, two, or three VSLs.

VSLs should be based on the guidelines shown in the table below:

Lower	Moderate	High	Severe
<p>Missing a minor element (or a small percentage) of the required performance</p> <p>The performance or product measured has significant value as it almost meets the full intent of the requirement.</p>	<p>Missing at least one significant element (or a moderate percentage) of the required performance.</p> <p>The performance or product measured still has significant value in meeting the intent of the requirement.</p>	<p>Missing more than one significant element (or is missing a high percentage) of the required performance or is missing a single vital Component.</p> <p>The performance or product has limited value in meeting the intent of the requirement.</p>	<p>Missing most or all of the significant elements (or a significant percentage) of the required performance.</p> <p>The performance measured does not meet the intent of the requirement or the product delivered cannot be used in meeting the intent of the requirement.</p>

FERC Order on VSLs

In its June 19, 2008 Order¹ on VSLs, FERC indicated it would use the following four guidelines² for determining whether to approve VSLs:

Guideline 1: VSL Assignments Should Not Have the Unintended Consequence of Lowering the Current Level of Compliance

- Compare the VSLs to any prior Levels of Non-compliance and avoid significant changes that may encourage a lower level of compliance than was required when Levels of Non-compliance were used.

Guideline 2: VSL Assignments Should Ensure Uniformity and Consistency in the Determination of Penalties

- Guideline 2a: A violation of a “binary” type requirement must be a “Severe” VSL.
- Guideline 2b: Do not use ambiguous terms such as “minor” and “significant” to describe noncompliant performance.

Guideline 3: VSL Assignment Should Be Consistent with the Corresponding Requirement

- VSLs should not expand on what is required in the requirement.

Guideline 4: VSL Assignment Should Be Based on A Single Violation, Not on A Cumulative Number of Violations

- . . . unless otherwise stated in the requirement, each instance of non-compliance with a requirement is a separate violation. Section 4 of the Sanction Guidelines states that assessing penalties on a per violation per day basis is the “default” for penalty calculations.

¹ *Order on Violation Severity Levels Proposed by the Electric Reliability Organization*, 125 FERC ¶61,248 (2008).

² *Id.* at P 17.

VRF and VSL Justifications

VRF and VSL Justifications – PRC-005-6, R1	
Proposed VRF	Medium
NERC VRF Discussion	Failure to establish a Protection System Maintenance Program (PSMP) for Protection Systems designed to provide protection for BES Element(s) could directly affect the electrical state or the capability of the bulk power system. However, violation of this requirement is unlikely to lead to bulk power system instability, separation, or cascading failures. The applicable entities are always responsible for maintaining the reliability of the bulk power system regardless of the situation. This VRF emphasizes the risk to system performance that results from mal-performing Protection System Components. Failure to establish a PSMP for Protection Systems will not, by itself, lead to instability, separation, or cascading failures. Thus, the requirement meets NERC’s criteria for a Medium VRF.
FERC VRF G1 Discussion	Guideline 1- Consistency w/ Blackout Report: N/A
FERC VRF G2 Discussion	Guideline 2- Consistency within a Reliability Standard: The requirement has no sub-requirements so only one VRF was assigned. The requirement utilizes Parts to identify the items to be included within a PSMP. The VRF for this requirement is consistent with others in the standard with regard to relative risk; therefore, there is no conflict.
FERC VRF G3 Discussion	Guideline 3- Consistency among Reliability Standards: The SDT has determined that there is no consistency among existing approved Standards relative to requirements of this nature. The SDT has assigned a MEDIUM VRF, which is consistent with recent FERC guidance on FAC-008-3 Requirement R2 and FAC-013-2 Requirement R1, which are similar in nature to PRC-005-6 Requirement R1.

VRF and VSL Justifications – PRC-005-6, R1			
Proposed VRF	Medium		
FERC VRF G4 Discussion	<p>Guideline 4- Consistency with NERC Definitions of VRFs:</p> <p>Failure to establish a PSMP for Protection Systems designed to provide protection for BES Element(s) could directly affect the electrical state or the capability of the bulk power system. However, violation of this requirement is unlikely to lead to bulk power system instability, separation, or cascading failures. The applicable entities are always responsible for maintaining the reliability of the bulk power system regardless of the situation. This VRF emphasizes the risk to system performance that results from mal-performing Protection System Components. Failure to establish a PSMP for Protection Systems will not, by itself, lead to instability, separation, or cascading failures. Thus, the requirement meets NERC’s criteria for a Medium VRF.</p>		
FERC VRF G5 Discussion	<p>Guideline 5- Treatment of Requirements that Co-mingle More than One Obligation:</p> <p>This requirement establishes a single risk-level, and the assigned VRF is consistent with that risk level.</p>		
Proposed VSL – PRC-005-6, R1			
Lower	Moderate	High	Severe
The entity’s PSMP failed to specify whether one Component Type is being addressed by time-based or performance-based maintenance, or a combination of both. (Part 1.1)	The entity’s PSMP failed to specify whether two Component Types are being addressed by time-based or performance-based maintenance, or a combination of both. (Part 1.1)	The entity’s PSMP failed to specify whether three Component Types are being addressed by time-based or performance-based maintenance, or a combination of both. (Part 1.1). OR	The entity failed to establish a PSMP. OR The entity’s PSMP failed to specify whether four or more Component Types are being addressed by time-based or performance-based maintenance, or a combination of both. (Part 1.1).

Proposed VSL – PRC-005-6, R1			
Lower	Moderate	High	Severe
		<p>The entity’s PSMP failed to include the applicable monitoring attributes applied to each Component Type consistent with the maintenance intervals specified in Tables 1-1 through 1-5, Table 2, Table 3, Table 4-1 through 4-3, and Table 5 where monitoring is used to extend the maintenance intervals beyond those specified for unmonitored Components. (Part 1.2).</p>	<p>OR</p> <p>The entity’s PSMP failed to include applicable station batteries in a time-based program (Part 1.1)</p>

VRF and VSL Justifications – PRC-005-6, R1	
NERC VSL Guidelines	Meets NERC’s VSL Guidelines—There is an incremental aspect that the violation and the VSLs follow the guidelines for incremental violations.
FERC VSL G1 VSL Assignments Should Not Have the Unintended Consequence of Lowering the Current Level of Compliance	This VSL is consistent with the current VSLs associated with the existing requirements of the standards being replaced by this proposed standard.
FERC VSL G2 VSL Level Assignments Should Ensure Uniformity and Consistency in the Determination of Penalties Guideline 2a: The Single VSL Assignment Category for "Binary" Requirements Is Not Consistent Guideline 2b: VSL Assignments that Contain Ambiguous Language	Guideline 2a: N/A Guideline 2b: The proposed VSL does not use any ambiguous terminology, thereby supporting uniformity and consistency in the determination of similar penalties for similar violations.

VRF and VSL Justifications – PRC-005-6, R1

FERC VSL G3 VSL Assignment Should Be Consistent with the Corresponding Requirement	The proposed VSL uses similar terminology to that used in the associated requirement and is, therefore, consistent with the requirement.
FERC VSL G4 VSL Assignment Should Be Based on A Single Violation, Not on A Cumulative Number of Violations	The VSL is based on a single violation and not cumulative violations.

VRF and VSL Justifications – PRC-005-6, R2	
Proposed VRF	Medium
NERC VRF Discussion	Failure to properly establish a performance-based PSMP for Protection Systems designed to provide protection for BES Element(s) could directly affect the electrical state or the capability of the bulk power system. However, violation of this requirement is unlikely to lead to bulk power system instability, separation, or cascading failures. The applicable entities are always responsible for maintaining the reliability of the bulk power system regardless of the situation. This VRF emphasizes the risk to system performance that results from mal-performing Protection System Components. Failure to properly establish a performance-based PSMP for Protection Systems will not, by itself, lead to instability, separation, or cascading failures. Thus, the requirement meets NERC’s criteria for a Medium VRF.
FERC VRF G1 Discussion	Guideline 1- Consistency w/ Blackout Report: N/A
FERC VRF G2 Discussion	Guideline 2- Consistency within a Reliability Standard: The requirement has no subpart(s); therefore, only one VRF was assigned and no conflict(s) exist.
FERC VRF G3 Discussion	Guideline 3- Consistency among Reliability Standards: The SDT has determined that there is no consistency among existing approved Standards relative to requirements of this nature. The SDT has assigned a MEDIUM VRF, which is consistent with recent FERC guidance on FAC-008-3 Requirement R2 and FAC-013-2 Requirement R1, which are similar in nature to PRC-005-6 Requirement R1.
FERC VRF G4 Discussion	Guideline 4- Consistency with NERC Definitions of VRFs: Failure to properly establish a performance-based PSMP for.

VRF and VSL Justifications – PRC-005-6, R2			
Proposed VRF	Medium		
	Protection Systems designed to provide protection for BES Element(s) could directly affect the electrical state or the capability of the bulk power system. However, violation of this requirement is unlikely to lead to bulk power system instability, separation, or cascading failures. The applicable entities are always responsible for maintaining the reliability of the bulk power system regardless of the situation. This VRF emphasizes the risk to system performance that results from mal-performing Protection System Components. Failure to properly establish a performance-based PSMP for Protection Systems will not, by itself, lead to instability, separation, or cascading failures. Thus, the requirement meets NERC’s criteria for a Medium VRF.		
FERC VRF G5 Discussion	Guideline 5- Treatment of Requirements that Co-mingle More than One Obligation: This requirement establishes a single risk-level, and the assigned VRF is consistent with that risk level.		
Proposed VSL – PRC-005-6, R2			
Lower	Moderate	High	Severe
The entity uses performance-based maintenance intervals in its PSMP but failed to reduce Countable Events to no more than 4% within three years.	N/A	The entity uses performance-based maintenance intervals in its PSMP but failed to reduce Countable Events to no more than 4% within four years.	The entity uses performance-based maintenance intervals in its PSMP but: 1) Failed to establish the technical justification described within Requirement R2 for the initial use of the performance-based PSMP

Proposed VSL – PRC-005-6, R2			
Lower	Moderate	High	Severe
			<p>OR</p> <p>2) Failed to reduce countable events to no more than 4% within five years</p> <p>OR</p> <p>3) Maintained a Segment with less than 60 Components</p> <p>OR</p> <p>4) Failed to:</p> <ul style="list-style-type: none"> • Annually update the list of Components, <p>OR</p> <ul style="list-style-type: none"> • Annually perform maintenance on the greater of 5% of the Segment population or 3 Components, <p>OR</p> <ul style="list-style-type: none"> • Annually analyze the program activities and results for each Segment.

VRF and VSL Justifications – PRC-005-6, R2	
NERC VSL Guidelines	Meets NERC’s VSL Guidelines—There is an incremental aspect that the violation and the VSLs follow the guidelines for incremental violations.
FERC VSL G1 VSL Assignments Should Not Have the Unintended Consequence of Lowering the Current Level of Compliance	This VSL is consistent with the current VSLs associated with the existing requirements of the standards being replaced by this proposed standard.
FERC VSL G2 VSL Assignments Should Ensure Uniformity and Consistency in the Determination of Penalties Guideline 2a: The Single VSL Assignment Category for "Binary" Requirements Is Not Consistent	Guideline 2a: N/A Guideline 2b: The proposed VSL does not use any ambiguous terminology, thereby supporting uniformity and consistency in the determination of similar penalties for similar violations.

VRF and VSL Justifications – PRC-005-6, R2

Guideline 2b: VSL Assignments that Contain Ambiguous Language	
FERC VSL G3 VSL Assignment Should Be Consistent with the Corresponding Requirement	The proposed VSL uses similar terminology to that used in the associated requirement and is, therefore, consistent with the requirement.
FERC VSL G4 VSL Assignment Should Be Based on A Single Violation, Not on A Cumulative Number of Violations	The VSL is based on a single violation and not cumulative violations.

VRF and VSL Justifications – PRC-005-6, R3	
Proposed VRF	High
NERC VRF Discussion	Failure to implement and follow its PSMP could, under emergency, abnormal, or restorative conditions anticipated by the preparations, directly cause or contribute to bulk electric system instability, separation, or a cascading sequence of failures, or could place the bulk electric system at an unacceptable risk of instability, separation, or cascading failures, or could hinder restoration to a normal condition. Thus, this requirement meets the criteria for a High VRF.
FERC VRF G1 Discussion	Guideline 1- Consistency w/ Blackout Report: N/A
FERC VRF G2 Discussion	Guideline 2- Consistency within a Reliability Standard: The requirement has no subpart(s); therefore, only one VRF was assigned and no conflict(s) exist.
FERC VRF G3 Discussion	Guideline 3- Consistency among Reliability Standards: The only Reliability Standards with similar goals are those being replaced by this standard, and the High VRF assignment for this requirement is consistent with the assigned VRFs for companion requirements in those existing standards.
FERC VRF G4 Discussion	Guideline 4- Consistency with NERC Definitions of VRFs: Failure to implement and follow its PSMP could, under emergency, abnormal, or restorative conditions anticipated by the preparations, directly cause or contribute to bulk electric system instability, separation, or a cascading sequence of failures, or could place the bulk electric system at an unacceptable risk of instability, separation, or cascading failures, or could hinder restoration to a normal condition. Thus, this requirement meets the criteria for a High VRF.
FERC VRF G5 Discussion	Guideline 5- Treatment of Requirements that Co-mingle More than One Obligation: This requirement establishes a single risk-level, and the assigned VRF is consistent with that risk level.

Proposed VSL – PRC-005-6, R3			
Lower	Moderate	High	Severe
For Components included within a time-based maintenance program, the entity failed to maintain 5% or less of the total Components included within a specific Component Type, in accordance with the minimum maintenance activities and maximum maintenance intervals prescribed within Tables 1-1 through 1-5, Table 2, Table 3, Table 4-1 through 4-3, and Table 5.	For Components included within a time-based maintenance program, the entity failed to maintain more than 5% but 10% or less of the total Components included within a specific Component Type, in accordance with the minimum maintenance activities and maximum maintenance intervals prescribed within Tables 1-1 through 1-5, Table 2, Table 3, Table 4-1 through 4-3, and Table 5.	For Components included within a time-based maintenance program, the entity failed to maintain more than 10% but 15% or less of the total Components included within a specific Component Type, in accordance with the minimum maintenance activities and maximum maintenance intervals prescribed within Tables 1-1 through 1-5, Table 2, Table 3, Table 4-1 through 4-3, and Table 5.	For Components included within a time-based maintenance program, the entity failed to maintain more than 15% of the total Components included within a specific Component Type, in accordance with the minimum maintenance activities and maximum maintenance intervals prescribed within Tables 1-1 through 1-5, Table 2, Table 3, Table 4-1 through 4-3, and Table 5.

VRF and VSL Justifications – PRC-005-6, R3	
NERC VSL Guidelines	Meets NERC’s VSL Guidelines—There is an incremental aspect that the violation and the VSLs follow the guidelines for incremental violations.
FERC VSL G1 VSL Assignments Should Not Have the Unintended Consequence of Lowering the Current Level of Compliance	This VSL is consistent with the current VSLs associated with the existing requirements of the standards being replaced by this proposed standard.
FERC VSL G2 VSL Assignments Should Ensure Uniformity and Consistency in the Determination of Penalties Guideline 2a: The Single VSL Assignment Category for "Binary" Requirements Is Not Consistent Guideline 2b: VSL Assignments that Contain Ambiguous Language	Guideline 2a: N/A Guideline 2b: The proposed VSL does not use any ambiguous terminology, thereby supporting uniformity and consistency in the determination of similar penalties for similar violations.

VRF and VSL Justifications – PRC-005-6, R3	
FERC VSL G3 VSL Assignment Should Be Consistent with the Corresponding Requirement	The proposed VSL uses similar terminology to that used in the associated requirement and is, therefore, consistent with the requirement.
FERC VSL G4 VSL Assignment Should Be Based on A Single Violation, Not on A Cumulative Number of Violations	The VSL is based on a single violation and not cumulative violations.

VRF and VSL Justifications – PRC-005-6, R4	
Proposed VRF	High
NERC VRF Discussion	Failure to implement and follow its PSMP could, under emergency, abnormal, or restorative conditions anticipated by the preparations, directly cause or contribute to bulk electric system instability, separation, or a cascading sequence of failures, or could place the bulk electric system at an unacceptable risk of instability, separation, or cascading failures, or could hinder restoration to a normal condition. Thus, this requirement meets the criteria for a High VRF.
FERC VRF G1 Discussion	Guideline 1- Consistency w/ Blackout Report: N/A
FERC VRF G2 Discussion	Guideline 2- Consistency within a Reliability Standard: The requirement has no subpart(s); therefore, only one VRF was assigned and no conflict(s) exist.
FERC VRF G3 Discussion	Guideline 3- Consistency among Reliability Standards: The only Reliability Standards with similar goals are those being replaced by this standard, and the High VRF assignment for this requirement is consistent with the assigned VRFs for companion requirements in those existing standards.
FERC VRF G4 Discussion	Guideline 4- Consistency with NERC Definitions of VRFs: Failure to implement and follow its PSMP could, under emergency, abnormal, or restorative conditions anticipated by the preparations, directly cause or contribute to bulk electric system instability, separation, or a cascading sequence of failures, or could place the bulk electric system at an unacceptable risk of instability, separation, or cascading failures, or could hinder restoration to a normal condition. Thus, this requirement meets the criteria for a High VRF.
FERC VRF G5 Discussion	Guideline 5- Treatment of Requirements that Co-mingle More than One Obligation: This requirement establishes a single risk-level, and the assigned VRF is consistent with that risk level.

Proposed VSL – PRC-005-6, R4			
Lower	Moderate	High	Severe
For Components included within a performance-based maintenance program, the entity failed to maintain 5% or less of the annual scheduled maintenance for a specific Component Type in accordance with their performance-based PSMP.	For Components included within a performance-based maintenance program, the entity failed to maintain more than 5% but 10% or less of the annual scheduled maintenance for a specific Component Type in accordance with their performance-based PSMP.	For Components included within a performance-based maintenance program, the entity failed to maintain more than 10% but 15% or less of the annual scheduled maintenance for a specific Component Type in accordance with their performance-based PSMP.	For Components included within a performance-based maintenance program, the entity failed to maintain more than 15% of the annual scheduled maintenance for a specific Component Type in accordance with their performance-based PSMP.

VRF and VSL Justifications – PRC-005-6, R4	
NERC VSL Guidelines	Meets NERC’s VSL Guidelines—There is an incremental aspect that the violation and the VSLs follow the guidelines for incremental violations.
FERC VSL G1 VSL Assignments Should Not Have the Unintended Consequence of Lowering the Current Level of Compliance	This VSL is consistent with the current VSLs associated with the existing requirements of the standards being replaced by this proposed standard.
FERC VSL G2 VSL Assignments Should Ensure Uniformity and Consistency in the Determination of Penalties Guideline 2a: The Single VSL Assignment Category for "Binary" Requirements Is Not Consistent Guideline 2b: VSL Assignments that Contain Ambiguous Language	Guideline 2a: N/A Guideline 2b: The proposed VSL does not use any ambiguous terminology, thereby supporting uniformity and consistency in the determination of similar penalties for similar violations.

VRF and VSL Justifications – PRC-005-6, R4

FERC VSL G3 VSL Assignment Should Be Consistent with the Corresponding Requirement	The proposed VSL uses similar terminology to that used in the associated requirement and is, therefore, consistent with the requirement.
FERC VSL G4 VSL Assignment Should Be Based on A Single Violation, Not on A Cumulative Number of Violations	The VSL is based on a single violation and not cumulative violations.

VRF and VSL Justifications – PRC-005-6, R5	
Proposed VRF	Medium
NERC VRF Discussion	Failure to initiate resolution of an unresolved maintenance issue for a Protection System Component could directly affect the electrical state or the capability of the bulk power system. However, violation of this requirement is unlikely to lead to bulk power system instability, separation, or cascading failures. The applicable entities are always responsible for maintaining the reliability of the bulk power system regardless of the situation. This VRF emphasizes the risk to system performance that results from mal-performing Protection System Components. Failure to initiate resolution of an unresolved maintenance issue for a Protection System Component will not, by itself, lead to instability, separation, or cascading failures. Thus, the requirement meets NERC’s criteria for a Medium VRF.
FERC VRF G1 Discussion	Guideline 1- Consistency w/ Blackout Report: N/A
FERC VRF G2 Discussion	Guideline 2- Consistency within a Reliability Standard: The requirement has no subpart(s); therefore, only one VRF was assigned and no conflict(s) exist.
FERC VRF G3 Discussion	Guideline 3- Consistency among Reliability Standards: The only requirement within approved Standards, PRC-004-2a Requirements R1 and R2 contain a similar requirement and is assigned a HIGH VRF. However, these requirements contain several subparts, and the VRF must address the most egregious risk related to these subparts, and a comparison to these requirements may be irrelevant. PRC-022-1 Requirement R1.5 contains only a similar requirement, and is assigned a MEDIUM VRF. FAC-003-2 Requirement R5 contains only a similar requirement, and is assigned a MEDIUM VRF.
FERC VRF G4 Discussion	Guideline 4- Consistency with NERC Definitions of VRFs: Failure to initiate resolution of an unresolved maintenance issue for a Protection System Component could directly affect the electrical state or the capability of the bulk power system.

VRF and VSL Justifications – PRC-005-6, R5			
Proposed VRF	Medium		
	However, violation of this requirement is unlikely to lead to bulk power system instability, separation, or cascading failures. The applicable entities are always responsible for maintaining the reliability of the bulk power system regardless of the situation. This VRF emphasizes the risk to system performance that results from mal-performing Protection System Components. Failure to initiate resolution of an unresolved maintenance issue for a Protection System Component will not, by itself, lead to instability, separation, or cascading failures. Thus, the requirement meets NERC’s criteria for a Medium VRF.		
FERC VRF G5 Discussion	Guideline 5- Treatment of Requirements that Co-mingle More than One Obligation: This requirement establishes a single risk-level, and the assigned VRF is consistent with that risk level.		
Proposed VSL – PRC-005-6, R5			
Lower	Moderate	High	Severe
The entity failed to undertake efforts to correct 5 or fewer identified Unresolved Maintenance Issues.	The entity failed to undertake efforts to correct greater than 5, but less than or equal to 10 identified Unresolved Maintenance Issues.	The entity failed to undertake efforts to correct greater than 10, but less than or equal to 15 identified Unresolved Maintenance Issues.	The entity failed to undertake efforts to correct greater than 15 identified Unresolved Maintenance Issues.

VRF and VSL Justifications – PRC-005-6, R5	
NERC VSL Guidelines	Meets NERC’s VSL Guidelines—There is an incremental aspect that the violation and the VSLs follow the guidelines for incremental violations.
FERC VSL G1 VSL Assignments Should Not Have the Unintended Consequence of Lowering the Current Level of Compliance	The Requirement in PRC-005-6 is identical to that in PRC-005-3, which has identical VSLs.
FERC VSL G2 VSL Assignments Should Ensure Uniformity and Consistency in the Determination of Penalties Guideline 2a: The Single VSL Assignment Category for "Binary" Requirements Is Not Consistent Guideline 2b: VSL Assignments that Contain Ambiguous Language	Guideline 2a: N/A Guideline 2b: The proposed VSL does not use any ambiguous terminology, thereby supporting uniformity and consistency in the determination of similar penalties for similar violations.

VRF and VSL Justifications – PRC-005-6, R5	
FERC VSL G3 VSL Assignment Should Be Consistent with the Corresponding Requirement	The proposed VSL uses similar terminology to that used in the associated requirement and is, therefore, consistent with the requirement.
FERC VSL G4 VSL Assignment Should Be Based on A Single Violation, Not on A Cumulative Number of Violations	The VSL is based on a single violation and not cumulative violations.

Violation Risk Factor and Violation Severity Level Justifications

Project 2007-17.4 PRC-005-6

Protection System, Automatic Reclosing and Sudden Pressure Relaying Maintenance

Violation Risk Factor and Violation Severity Level Justifications

This document provides the drafting team's justification for assignment of violation risk factors (VRFs) and violation severity levels (VSLs) for each requirement in PRC-005-62 - Protection System, Automatic Reclosing and Sudden Pressure Relaying Maintenance.

Each primary requirement is assigned a VRF and a set of one or more VSLs. These elements support the determination of an initial value range for the Base Penalty Amount regarding violations of requirements in FERC-approved Reliability Standards, as defined in the ERO Sanction Guidelines.

The Protection System Maintenance and Testing Standard Drafting Team (SDT) applied the following NERC criteria and FERC Guidelines when proposing VRFs and VSLs for the requirements under this project:

NERC Criteria – VRFs

High Risk Requirement

A requirement that, if violated, could directly cause or contribute to bulk electric system instability, separation, or a cascading sequence of failures, or could place the bulk electric system at an unacceptable risk of instability, separation, or cascading failures; or, a requirement in a planning time frame that, if violated, could, under emergency, abnormal, or restorative conditions anticipated by the preparations, directly cause or contribute to bulk electric system instability, separation, or a cascading sequence of failures, or could place the bulk electric system at an unacceptable risk of instability, separation, or cascading failures, or could hinder restoration to a normal condition.

Medium Risk Requirement

A requirement that, if violated, could directly affect the electrical state or the capability of the bulk electric system, or the ability to effectively monitor and control the bulk electric system. However, violation of a medium risk requirement is unlikely to lead to bulk electric system instability, separation, or cascading failures; or, a requirement in a planning time frame that, if violated, could, under emergency, abnormal, or restorative conditions anticipated by the preparations, directly and adversely affect the electrical state or capability of the bulk electric system, or the ability to effectively monitor, control, or restore the bulk electric system. However, violation of a medium risk

requirement is unlikely, under emergency, abnormal, or restoration conditions anticipated by the preparations, to lead to bulk electric system instability, separation, or cascading failures, nor to hinder restoration to a normal condition.

Lower Risk Requirement

A requirement that is administrative in nature and a requirement that, if violated, would not be expected to adversely affect the electrical state or capability of the bulk electric system, or the ability to effectively monitor and control the bulk electric system; or, a requirement that is administrative in nature and a requirement in a planning time frame that, if violated, would not, under the emergency, abnormal, or restorative conditions anticipated by the preparations, be expected to adversely affect the electrical state or capability of the bulk electric system, or the ability to effectively monitor, control, or restore the bulk electric system. A planning requirement that is administrative in nature.

FERC VRF Guidelines

Guideline (1) – Consistency with the Conclusions of the Final Blackout Report

The Commission seeks to ensure that VRFs assigned to Requirements of Reliability Standards in these identified areas appropriately reflect their historical critical impact on the reliability of the Bulk-Power System.

In the VSL Order, FERC listed critical areas (from the Final Blackout Report) where violations could severely affect the reliability of the Bulk-Power System:

- Emergency operations
- Vegetation management
- Operator personnel training
- Protection systems and their coordination
- Operating tools and backup facilities
- Reactive power and voltage control
- System modeling and data exchange
- Communication protocol and facilities
- Requirements to determine equipment ratings
- Synchronized data recorders
- Clearer criteria for operationally critical facilities
- Appropriate use of transmission loading relief

Guideline (2) – Consistency within a Reliability Standard

The Commission expects a rational connection between the sub-Requirement VRF assignments and the main Requirement VRF assignment.

Guideline (3) — Consistency among Reliability Standards

The Commission expects the assignment of VRFs corresponding to Requirements that address similar reliability goals in different Reliability Standards would be treated comparably.

Guideline (4) — Consistency with NERC’s Definition of the VRF Level

Guideline (4) was developed to evaluate whether the assignment of a particular VRF level conforms to NERC’s definition of that risk level.

Guideline (5) — Treatment of Requirements that Co-mingle More Than One Obligation

Where a single Requirement co-mingles a higher risk reliability objective and a lesser risk reliability objective, the VRF assignment for such Requirements must not be watered down to reflect the lower risk level associated with the less important objective of the Reliability Standard.

The following discussion addresses how the SDT considered FERC’s VRF Guidelines 2 through 5. The team did not address Guideline 1 directly because of an apparent conflict between Guidelines 1 and 4. Whereas Guideline 1 identifies a list of topics that encompass nearly all topics within NERC’s Reliability Standards and implies that these requirements should be assigned a “High” VRF, Guideline 4 directs assignment of VRFs based on the impact of a specific requirement to the reliability of the system. The SDT believes that Guideline 4 is reflective of the intent of VRFs in the first instance and therefore concentrated its approach on the reliability impact of the requirements.

PRC-005-~~X-6~~ Protection System, Automatic Reclosing and Sudden Pressure Relaying Maintenance is a revision of PRC-005-3 Protection System and Automatic Reclosing Maintenance with the stated purpose: To document and implement programs for the maintenance of all Protection Systems, Automatic Reclosing, and Sudden Pressure Relaying affecting the reliability of the Bulk Electric System (BES) so that they are kept in working order.

PRC-005-~~X-6~~ has five (5) requirements that address the inclusion of Sudden Pressure Relaying. A Table of minimum maintenance activities and maximum maintenance intervals for Sudden Pressure Relaying has been added to PRC-005-3 to address FERC’s directives from Order 758. The revised standard requires that entities develop an appropriate Protection System Maintenance Program (PSMP), that they implement their PSMP, and that, in the event they are unable to restore Sudden Pressure Relaying Components to proper working order while performing maintenance, they initiate the follow-up activities necessary to resolve those maintenance issues.

The requirements of PRC-005-~~X-6~~ map one-to-one with the requirements of PRC-005-3. The drafting team did not revise the VRFs for the requirements of PRC-005-3 in PRC-005-6.

PRC-005-~~X-6~~ Requirements R1 and R2 are related to developing and documenting a Protection System Maintenance Program. The ~~SDT~~Standard Drafting Team determined that the assignment of a VRF of Medium was consistent with the NERC criteria that violations of these requirements could directly affect the electrical state or the capability of the bulk electric system, or the ability to effectively monitor and control the bulk electric system but are unlikely to lead to bulk electric

system instability, separation, or cascading failures. Additionally, a review of the body of existing NERC Standards with approved VRFs revealed that requirements with similar reliability objectives in other standards are largely assigned a VRF of Medium.

PRC-005-~~5~~4 Requirements R3 and R4 are related to implementation of the Protection System Maintenance Program. The SDT determined that the assignment of a VRF of High was consistent with the NERC criteria that that violation of these requirements could directly cause or contribute to bulk electric system instability, separation, or a cascading sequence of failures, or could place the bulk electric system at an unacceptable risk of instability, separation, or cascading failures. Additionally, a review of the body of existing NERC Standards with approved VRFs revealed that requirements with similar reliability objectives in other standards are assigned a VRF of High.

PRC-005-~~X~~6 Requirement R5 relates to the initiation of actions resulting in resolution of unresolved maintenance issues, which describe situations where an entity was unable to restore a Component to proper working order during the performance of the maintenance activity. The ~~SDT standard Drafting Team~~ determined that the assignment of a VRF of Medium was consistent with the NERC criteria that violation of this requirements could directly affect the electrical state or the capability of the bulk electric system, or the ability to effectively monitor and control the bulk electric system but are unlikely to lead to bulk electric system instability, separation, or cascading failures. Additionally, a review of the body of existing NERC Standards with approved VRFs revealed that requirements with similar reliability objectives in other standards are largely assigned a VRF of Medium.

NERC Criteria - VSLs

VSLs define the degree to which compliance with a requirement was not achieved. Each requirement must have at least one VSL. While it is preferable to have four VSLs for each requirement, some requirements do not have multiple “degrees” of noncompliant performance and may have only one, two, or three VSLs.

VSLs should be based on the guidelines shown in the table below:

Lower	Moderate	High	Severe
<p>Missing a minor element (or a small percentage) of the required performance</p> <p>The performance or product measured has significant value as it almost meets the full intent of the requirement.</p>	<p>Missing at least one significant element (or a moderate percentage) of the required performance.</p> <p>The performance or product measured still has significant value in meeting the intent of the requirement.</p>	<p>Missing more than one significant element (or is missing a high percentage) of the required performance or is missing a single vital Component.</p> <p>The performance or product has limited value in meeting the intent of the requirement.</p>	<p>Missing most or all of the significant elements (or a significant percentage) of the required performance.</p> <p>The performance measured does not meet the intent of the requirement or the product delivered cannot be used in meeting the intent of the requirement.</p>

FERC Order on VSLs

In its June 19, 2008 Order¹ on VSLs, FERC indicated it would use the following four guidelines² for determining whether to approve VSLs:

Guideline 1: VSL Assignments Should Not Have the Unintended Consequence of Lowering the Current Level of Compliance

- Compare the VSLs to any prior Levels of Non-compliance and avoid significant changes that may encourage a lower level of compliance than was required when Levels of Non-compliance were used.

Guideline 2: VSL Assignments Should Ensure Uniformity and Consistency in the Determination of Penalties

- Guideline 2a: A violation of a “binary” type requirement must be a “Severe” VSL.
- Guideline 2b: Do not use ambiguous terms such as “minor” and “significant” to describe noncompliant performance.

Guideline 3: VSL Assignment Should Be Consistent with the Corresponding Requirement

- VSLs should not expand on what is required in the requirement.

Guideline 4: VSL Assignment Should Be Based on A Single Violation, Not on A Cumulative Number of Violations

- . . . unless otherwise stated in the requirement, each instance of non-compliance with a requirement is a separate violation. Section 4 of the Sanction Guidelines states that assessing penalties on a per violation per day basis is the “default” for penalty calculations.

¹ *Order on Violation Severity Levels Proposed by the Electric Reliability Organization*, 125 FERC ¶61,248 (2008).

² *Id.* at P 17.

VRF and VSL Justifications

VRF and VSL Justifications – PRC-005- X-5 , R1	
Proposed VRF	Medium
NERC VRF Discussion	Failure to establish a Protection System Maintenance Program (PSMP) for Protection Systems designed to provide protection for BES Element(s) could directly affect the electrical state or the capability of the bulk power system. However, violation of this requirement is unlikely to lead to bulk power system instability, separation, or cascading failures. The applicable entities are always responsible for maintaining the reliability of the bulk power system regardless of the situation. This VRF emphasizes the risk to system performance that results from mal-performing Protection System Components. Failure to establish a Protection System Maintenance Program (PSMP) for Protection Systems will not, by itself, lead to instability, separation, or cascading failures. Thus, the requirement meets NERC’s criteria for a Medium VRF.
FERC VRF G1 Discussion	Guideline 1- Consistency w/ Blackout Report: N/A
FERC VRF G2 Discussion	Guideline 2- Consistency within a Reliability Standard: The requirement has no sub-requirements so only one VRF was assigned. The requirement utilizes Parts to identify the items to be included within a PSMP Protection System Maintenance Program . The VRF for this requirement is consistent with others in the standard with regard to relative risk; therefore, there is no conflict.
FERC VRF G3 Discussion	Guideline 3- Consistency among Reliability Standards: The SDT has determined that there is no consistency among existing approved Standards relative to requirements of this nature. The SDT has assigned a MEDIUM VRF, which is consistent with recent FERC guidance on FAC-008-3 Requirement R2 and FAC-013-2 Requirement R1, which are similar in nature to PRC-005- X-6 Requirement R1.

VRF and VSL Justifications – PRC-005- X-5 , R1			
Proposed VRF	Medium		
FERC VRF G4 Discussion	<p>Guideline 4- Consistency with NERC Definitions of VRFs:</p> <p>Failure to establish a Protection System Maintenance Program (PSMP) for Protection Systems designed to provide protection for BES Element(s) could directly affect the electrical state or the capability of the bulk power system. However, violation of this requirement is unlikely to lead to bulk power system instability, separation, or cascading failures. The applicable entities are always responsible for maintaining the reliability of the bulk power system regardless of the situation. This VRF emphasizes the risk to system performance that results from mal-performing Protection System Components. Failure to establish a Protection System Maintenance Program (PSMP) for Protection Systems will not, by itself, lead to instability, separation, or cascading failures. Thus, the requirement meets NERC’s criteria for a Medium VRF.</p>		
FERC VRF G5 Discussion	<p>Guideline 5- Treatment of Requirements that Co-mingle More than One Obligation:</p> <p>This requirement establishes a single risk-level, and the assigned VRF is consistent with that risk level.</p>		
Proposed VSL – PRC-005- X-5 , R1			
Lower	Moderate	High	Severe
The entity’s PSMP failed to specify whether one Component Type is being addressed by time-based or performance-based maintenance, or a combination of both. (Part 1.1)	The entity’s PSMP failed to specify whether two Component Types are being addressed by time-based or performance-based maintenance, or a combination of both. (Part 1.1)	The entity’s PSMP failed to specify whether three Component Types are being addressed by time-based or performance-based maintenance, or a combination of both. (Part 1.1). OR	The entity failed to establish a PSMP. OR The entity’s PSMP failed to specify whether four or more Component Types are being addressed by time-based or performance-based maintenance, or a combination of both. (Part 1.1).

Proposed VSL – PRC-005- X-5 , R1			
Lower	Moderate	High	Severe
		<p>The entity’s PSMP failed to include the applicable monitoring attributes applied to each Component Type consistent with the maintenance intervals specified in Tables 1-1 through 1-5, Table 2, Table 3, Table 4-1 through 4-23, and Table 5 where monitoring is used to extend the maintenance intervals beyond those specified for unmonitored Components. (Part 1.2).</p>	<p>OR</p> <p>The entity’s PSMP failed to include applicable station batteries in a time-based program (Part 1.1)</p>

VRF and VSL Justifications – PRC-005- 4-6 , R1	
NERC VSL Guidelines	Meets NERC’s VSL Guidelines—There is an incremental aspect thate the violation and the VSLs follow the guidelines for incremental violations.
FERC VSL G1 VSL Assignments Should Not Have the Unintended Consequence of Lowering the Current Level of Compliance	This VSL is consistent with the current VSLs associated with the existing requirements of the standards being replaced by this proposed standard.
FERC VSL G2 VSL Level Assignments Should Ensure Uniformity and Consistency in the Determination of Penalties Guideline 2a: The Single VSL Assignment Category for "Binary" Requirements Is Not Consistent Guideline 2b: VSL Assignments that Contain Ambiguous Language	Guideline 2a: N/A Guideline 2b: The proposed VSL does not use any ambiguous terminology, thereby supporting uniformity and consistency in the determination of similar penalties for similar violations.

VRF and VSL Justifications – PRC-005-~~X-5~~, R1

<p>FERC VSL G3 VSL Assignment Should Be Consistent with the Corresponding Requirement</p>	<p>The proposed VSL uses similar terminology to that used in the associated requirement, and is therefore consistent with the requirement.</p>
<p>FERC VSL G4 VSL Assignment Should Be Based on A Single Violation, Not on A Cumulative Number of Violations</p>	<p>The VSL is based on a single violation and not cumulative violations.</p>

VRF and VSL Justifications – PRC-005- X-5 , R2	
Proposed VRF	Medium
NERC VRF Discussion	Failure to properly establish a performance-based Protection System Maintenance Program (PSMP) for Protection Systems designed to provide protection for BES Element(s) could directly affect the electrical state or the capability of the bulk power system. However, violation of this requirement is unlikely to lead to bulk power system instability, separation, or cascading failures. The applicable entities are always responsible for maintaining the reliability of the bulk power system regardless of the situation. This VRF emphasizes the risk to system performance that results from mal-performing Protection System Components. Failure to properly establish a performance-based Protection System Maintenance Program (PSMP) for Protection Systems will not, by itself, lead to instability, separation, or cascading failures. Thus, the requirement meets NERC’s criteria for a Medium VRF.
FERC VRF G1 Discussion	Guideline 1- Consistency w/ Blackout Report: N/A
FERC VRF G2 Discussion	Guideline 2- Consistency within a Reliability Standard: The requirement has no subpart(s); therefore, only one VRF was assigned and no conflict(s) exist.
FERC VRF G3 Discussion	Guideline 3- Consistency among Reliability Standards: The SDT has determined that there is no consistency among existing approved Standards relative to requirements of this nature. The SDT has assigned a MEDIUM VRF, which is consistent with recent FERC guidance on FAC-008-3 Requirement R2 and FAC-013-2 Requirement R1, which are similar in nature to PRC-005- X-6 Requirement R1.
FERC VRF G4 Discussion	Guideline 4- Consistency with NERC Definitions of VRFs: Failure to properly establish a performance-based Protection System Maintenance Program (PSMP) for.

VRF and VSL Justifications – PRC-005- X-5 , R2			
Proposed VRF	Medium		
	<p>Protection Systems designed to provide protection for BES Element(s) could directly affect the electrical state or the capability of the bulk power system. However, violation of this requirement is unlikely to lead to bulk power system instability, separation, or cascading failures. The applicable entities are always responsible for maintaining the reliability of the bulk power system regardless of the situation. This VRF emphasizes the risk to system performance that results from mal-performing Protection System Components. Failure to properly establish a performance-based Protection System Maintenance Program (PSMP) for Protection Systems will not, by itself, lead to instability, separation, or cascading failures. Thus, the requirement meets NERC’s criteria for a Medium VRF.</p>		
FERC VRF G5 Discussion	<p>Guideline 5- Treatment of Requirements that Co-mingle More than One Obligation: This requirement establishes a single risk-level, and the assigned VRF is consistent with that risk level.</p>		
Proposed VSL – PRC-005- X-5 , R2			
Lower	Moderate	High	Severe
The entity uses performance-based maintenance intervals in its PSMP but failed to reduce Countable Events to no more than 4% within three years.	N/A	The entity uses performance-based maintenance intervals in its PSMP but failed to reduce Countable Events to no more than 4% within four years.	<p>The entity uses performance-based maintenance intervals in its PSMP but:</p> <ol style="list-style-type: none"> 1) Failed to establish the technical justification described within Requirement R2 for the initial use of the performance-based PSMP

Proposed VSL – PRC-005- 4.5 , R2			
Lower	Moderate	High	Severe
			<p>OR</p> <p>2) Failed to reduce countable events to no more than 4% within five years</p> <p>OR</p> <p>3) Maintained a Segment with less than 60 Components</p> <p>OR</p> <p>4) Failed to:</p> <ul style="list-style-type: none"> • Annually update the list of Components, <p>OR</p> <ul style="list-style-type: none"> • Annually perform maintenance on the greater of 5% of the Segment population or 3 Components, <p>OR</p> <ul style="list-style-type: none"> • Annually analyze the program activities and results for each Segment.

VRF and VSL Justifications – PRC-005- X-5 , R2	
NERC VSL Guidelines	Meets NERC’s VSL Guidelines—There is an incremental aspect <u>thate</u> the violation and the VSLs follow the guidelines for incremental violations.
FERC VSL G1 VSL Assignments Should Not Have the Unintended Consequence of Lowering the Current Level of Compliance	This VSL is consistent with the current VSLs associated with the existing requirements of the standards being replaced by this proposed standard.
FERC VSL G2 VSL Assignments Should Ensure Uniformity and Consistency in the Determination of Penalties Guideline 2a: The Single VSL Assignment Category for "Binary" Requirements Is Not Consistent	Guideline 2a: N/A Guideline 2b: The proposed VSL does not use any ambiguous terminology, thereby supporting uniformity and consistency in the determination of similar penalties for similar violations.

VRF and VSL Justifications – PRC-005-~~X-5~~, R2

Guideline 2b: VSL Assignments that Contain Ambiguous Language	
FERC VSL G3 VSL Assignment Should Be Consistent with the Corresponding Requirement	The proposed VSL uses similar terminology to that used in the associated requirement, and is therefore, consistent with the requirement.
FERC VSL G4 VSL Assignment Should Be Based on A Single Violation, Not on A Cumulative Number of Violations	The VSL is based on a single violation and not cumulative violations.

VRF and VSL Justifications – PRC-005- X-5 , R3	
Proposed VRF	High
NERC VRF Discussion	Failure to implement and follow its Protection System Maintenance Program (PSMP) could, under emergency, abnormal, or restorative conditions anticipated by the preparations, directly cause or contribute to bulk electric system instability, separation, or a cascading sequence of failures, or could place the bulk electric system at an unacceptable risk of instability, separation, or cascading failures, or could hinder restoration to a normal condition. Thus, this requirement meets the criteria for a High VRF.
FERC VRF G1 Discussion	Guideline 1- Consistency w/ Blackout Report: N/A
FERC VRF G2 Discussion	Guideline 2- Consistency within a Reliability Standard: The requirement has no subpart(s); therefore, only one VRF was assigned and no conflict(s) exist.
FERC VRF G3 Discussion	Guideline 3- Consistency among Reliability Standards: The only Reliability Standards with similar goals are those being replaced by this standard, and the High VRF assignment for this requirement is consistent with the assigned VRFs for companion requirements in those existing standards.
FERC VRF G4 Discussion	Guideline 4- Consistency with NERC Definitions of VRFs: Failure to implement and follow its Protection System Maintenance Program (PSMP) could, under emergency, abnormal, or restorative conditions anticipated by the preparations, directly cause or contribute to bulk electric system instability, separation, or a cascading sequence of failures, or could place the bulk electric system at an unacceptable risk of instability, separation, or cascading failures, or could hinder restoration to a normal condition. Thus, this requirement meets the criteria for a High VRF.
FERC VRF G5 Discussion	Guideline 5- Treatment of Requirements that Co-mingle More than One Obligation: This requirement establishes a single risk-level, and the assigned VRF is consistent with that risk level.

Proposed VSL – PRC-005- 4.5 , R3			
Lower	Moderate	High	Severe
For Components included within a time-based maintenance program, the entity failed to maintain 5% or less of the total Components included within a specific Component Type, in accordance with the minimum maintenance activities and maximum maintenance intervals prescribed within Tables 1-1 through 1-5, Table 2, Table 3, Table 4-1 through 4- 32 , and Table 5.	For Components included within a time-based maintenance program, the entity failed to maintain more than 5% but 10% or less of the total Components included within a specific Component Type, in accordance with the minimum maintenance activities and maximum maintenance intervals prescribed within Tables 1-1 through 1-5, Table 2, Table 3, Table 4-1 through 4- 32 , and Table 5.	For Components included within a time-based maintenance program, the entity failed to maintain more than 10% but 15% or less of the total Components included within a specific Component Type, in accordance with the minimum maintenance activities and maximum maintenance intervals prescribed within Tables 1-1 through 1-5, Table 2, Table 3, Table 4-1 through 4- 32 , and Table 5.	For Components included within a time-based maintenance program, the entity failed to maintain more than 15% of the total Components included within a specific Component Type, in accordance with the minimum maintenance activities and maximum maintenance intervals prescribed within Tables 1-1 through 1-5, Table 2, Table 3, Table 4-1 through 4- 32 , and Table 5.

VRF and VSL Justifications – PRC-005-X-6, R3	
NERC VSL Guidelines	Meets NERC’s VSL Guidelines—There is an incremental aspect thate the violation and the VSLs follow the guidelines for incremental violations.
FERC VSL G1 VSL Assignments Should Not Have the Unintended Consequence of Lowering the Current Level of Compliance	This VSL is consistent with the current VSLs associated with the existing requirements of the standards being replaced by this proposed standard.
FERC VSL G2 VSL Assignments Should Ensure Uniformity and Consistency in the Determination of Penalties Guideline 2a: The Single VSL Assignment Category for "Binary" Requirements Is Not Consistent Guideline 2b: VSL Assignments that Contain Ambiguous Language	Guideline 2a: N/A Guideline 2b: The proposed VSL does not use any ambiguous terminology, thereby supporting uniformity and consistency in the determination of similar penalties for similar violations.

VRF and VSL Justifications – PRC-005-~~4.5~~, R3

<p>FERC VSL G3 VSL Assignment Should Be Consistent with the Corresponding Requirement</p>	<p>The proposed VSL uses similar terminology to that used in the associated requirement, and is therefore, consistent with the requirement.</p>
<p>FERC VSL G4 VSL Assignment Should Be Based on A Single Violation, Not on A Cumulative Number of Violations</p>	<p>The VSL is based on a single violation and not cumulative violations.</p>

VRF and VSL Justifications – PRC-005- X-6 , R4	
Proposed VRF	High
NERC VRF Discussion	Failure to implement and follow its Protection System Maintenance Program (PSMP) could, under emergency, abnormal, or restorative conditions anticipated by the preparations, directly cause or contribute to bulk electric system instability, separation, or a cascading sequence of failures, or could place the bulk electric system at an unacceptable risk of instability, separation, or cascading failures, or could hinder restoration to a normal condition. Thus, this requirement meets the criteria for a High VRF.
FERC VRF G1 Discussion	Guideline 1- Consistency w/ Blackout Report: N/A
FERC VRF G2 Discussion	Guideline 2- Consistency within a Reliability Standard: The requirement has no subpart(s); therefore, only one VRF was assigned and no conflict(s) exist.
FERC VRF G3 Discussion	Guideline 3- Consistency among Reliability Standards: The only Reliability Standards with similar goals are those being replaced by this standard, and the High VRF assignment for this requirement is consistent with the assigned VRFs for companion requirements in those existing standards.
FERC VRF G4 Discussion	Guideline 4- Consistency with NERC Definitions of VRFs: Failure to implement and follow its Protection System Maintenance Program (PSMP) could, under emergency, abnormal, or restorative conditions anticipated by the preparations, directly cause or contribute to bulk electric system instability, separation, or a cascading sequence of failures, or could place the bulk electric system at an unacceptable risk of instability, separation, or cascading failures, or could hinder restoration to a normal condition. Thus, this requirement meets the criteria for a High VRF.
FERC VRF G5 Discussion	Guideline 5- Treatment of Requirements that Co-mingle More than One Obligation: This requirement establishes a single risk-level, and the assigned VRF is consistent with that risk level.

Proposed VSL – PRC-005- 4.5 , R4			
Lower	Moderate	High	Severe
For Components included within a performance-based maintenance program, the entity failed to maintain 5% or less of the annual scheduled maintenance for a specific Component Type in accordance with their performance-based PSMP.	For Components included within a performance-based maintenance program, the entity failed to maintain more than 5% but 10% or less of the annual scheduled maintenance for a specific Component Type in accordance with their performance-based PSMP.	For Components included within a performance-based maintenance program, the entity failed to maintain more than 10% but 15% or less of the annual scheduled maintenance for a specific Component Type in accordance with their performance-based PSMP.	For Components included within a performance-based maintenance program, the entity failed to maintain more than 15% of the annual scheduled maintenance for a specific Component Type in accordance with their performance-based PSMP.

VRF and VSL Justifications – PRC-005- X-5 , R4	
NERC VSL Guidelines	Meets NERC’s VSL Guidelines—There is an incremental aspect thate the violation and the VSLs follow the guidelines for incremental violations.
FERC VSL G1 VSL Assignments Should Not Have the Unintended Consequence of Lowering the Current Level of Compliance	This VSL is consistent with the current VSLs associated with the existing requirements of the standards being replaced by this proposed standard.
FERC VSL G2 VSL Assignments Should Ensure Uniformity and Consistency in the Determination of Penalties Guideline 2a: The Single VSL Assignment Category for "Binary" Requirements Is Not Consistent Guideline 2b: VSL Assignments that Contain Ambiguous Language	Guideline 2a: N/A Guideline 2b: The proposed VSL does not use any ambiguous terminology, thereby supporting uniformity and consistency in the determination of similar penalties for similar violations.

VRF and VSL Justifications – PRC-005-~~X-5~~, R4

FERC VSL G3
VSL Assignment Should Be
Consistent with the
Corresponding Requirement

The proposed VSL uses similar terminology to that used in the associated requirement, and is therefore consistent with the requirement.

FERC VSL G4
VSL Assignment Should Be
Based on A Single Violation, Not
on A Cumulative Number of
Violations

The VSL is based on a single violation and not cumulative violations.

VRF and VSL Justifications – PRC-005- X-5 , R5	
Proposed VRF	Medium
NERC VRF Discussion	Failure to initiate resolution of an unresolved maintenance issue for a Protection System Component could directly affect the electrical state or the capability of the bulk power system. However, violation of this requirement is unlikely to lead to bulk power system instability, separation, or cascading failures. The applicable entities are always responsible for maintaining the reliability of the bulk power system regardless of the situation. This VRF emphasizes the risk to system performance that results from mal-performing Protection System Components. Failure to initiate resolution of an unresolved maintenance issue for a Protection System Component will not, by itself, lead to instability, separation, or cascading failures. Thus, the requirement meets NERC’s criteria for a Medium VRF.
FERC VRF G1 Discussion	Guideline 1- Consistency w/ Blackout Report: N/A
FERC VRF G2 Discussion	Guideline 2- Consistency within a Reliability Standard: The requirement has no subpart(s); therefore, only one VRF was assigned and no conflict(s) exist.
FERC VRF G3 Discussion	Guideline 3- Consistency among Reliability Standards: The only requirement within approved Standards, PRC-004-2a Requirements R1 and R2 contain a similar requirement and is assigned a HIGH VRF. However, these requirements contain several subparts, and the VRF must address the most egregious risk related to these subparts, and a comparison to these requirements may be irrelevant. PRC-022-1 Requirement R1.5 contains only a similar requirement, and is assigned a MEDIUM VRF. FAC-003-2 Requirement R5 contains only a similar requirement, and is assigned a MEDIUM VRF.
FERC VRF G4 Discussion	Guideline 4- Consistency with NERC Definitions of VRFs: Failure to initiate resolution of an unresolved maintenance issue for a Protection System Component could directly affect the electrical state or the capability of the bulk power system.

VRF and VSL Justifications – PRC-005- X-5 , R5			
Proposed VRF	Medium		
	However, violation of this requirement is unlikely to lead to bulk power system instability, separation, or cascading failures. The applicable entities are always responsible for maintaining the reliability of the bulk power system regardless of the situation. This VRF emphasizes the risk to system performance that results from mal-performing Protection System Components. Failure to initiate resolution of an unresolved maintenance issue for a Protection System Component will not, by itself, lead to instability, separation, or cascading failures. Thus, the requirement meets NERC’s criteria for a Medium VRF.		
FERC VRF G5 Discussion	Guideline 5- Treatment of Requirements that Co-mingle More than One Obligation: This requirement establishes a single risk-level, and the assigned VRF is consistent with that risk level.		
Proposed VSL – PRC-005- X-6 , R5			
Lower	Moderate	High	Severe
The entity failed to undertake efforts to correct 5 or fewer identified Unresolved Maintenance Issues.	The entity failed to undertake efforts to correct greater than 5, but less than or equal to 10 identified Unresolved Maintenance Issues.	The entity failed to undertake efforts to correct greater than 10, but less than or equal to 15 identified Unresolved Maintenance Issues.	The entity failed to undertake efforts to correct greater than 15 identified Unresolved Maintenance Issues.

VRF and VSL Justifications – PRC-005- 6 , R5	
NERC VSL Guidelines	Meets NERC’s VSL Guidelines—There is an incremental aspect thate the violation and the VSLs follow the guidelines for incremental violations.
FERC VSL G1 VSL Assignments Should Not Have the Unintended Consequence of Lowering the Current Level of Compliance	The Requirement in PRC-005- X-6 is identical to that in PRC-005-3, which has identical VSLs.
FERC VSL G2 VSL Assignments Should Ensure Uniformity and Consistency in the Determination of Penalties Guideline 2a: The Single VSL Assignment Category for "Binary" Requirements Is Not Consistent Guideline 2b: VSL Assignments that Contain Ambiguous Language	Guideline 2a: N/A Guideline 2b: The proposed VSL does not use any ambiguous terminology, thereby supporting uniformity and consistency in the determination of similar penalties for similar violations.

VRF and VSL Justifications – PRC-005-~~4-6~~, R5

FERC VSL G3 VSL Assignment Should Be Consistent with the Corresponding Requirement	The proposed VSL uses similar terminology to that used in the associated requirement, and is, therefore, consistent with the requirement.
FERC VSL G4 VSL Assignment Should Be Based on A Single Violation, Not on A Cumulative Number of Violations	The VSL is based on a single violation and not cumulative violations.

~~VRF and VSL Justifications — PRC-005-4, R6~~

~~FERC VSL G3
VSL Assignment Should Be
Consistent with the
Corresponding Requirement~~

~~The proposed VSL uses similar terminology to that used in the associated requirement, and is therefore consistent with the requirement.~~

~~FERC VSL G4
VSL Assignment Should Be
Based on A Single Violation, Not
on A Cumulative Number of
Violations~~

~~The VSL is based on a single violation and not cumulative violations.~~

NERC

NORTH AMERICAN ELECTRIC
RELIABILITY CORPORATION

Supplementary Reference and FAQ

PRC-005-6 Protection System, Automatic
Reclosing, and Sudden Pressure Relaying
Maintenance and Testing

July 2015

RELIABILITY | ACCOUNTABILITY



3353 Peachtree Road NE
Suite 600, North Tower
Atlanta, GA 30326
404-446-2560 | www.nerc.com

Table of Contents

Table of Contents.....	ii
1. Introduction and Summary.....	1
2. Need for Verifying Protection System Performance	2
2.1 Existing NERC Standards for Protection System Maintenance and Testing	2
2.2 Protection System Definition	3
2.3 Applicability of New Protection System Maintenance Standards	3
2.3.1 Frequently Asked Questions:	4
2.4.1 Frequently Asked Questions:	6
3. Protection System and Automatic Reclosing Product Generations	13
4. Definitions.....	15
4.1 Frequently Asked Questions:	16
5. Time-Based Maintenance (TBM) Programs.....	18
5.1 Maintenance Practices.....	18
5.1.1 Frequently Asked Questions:	20
5.2 Extending Time-Based Maintenance	21
5.2.1 Frequently Asked Questions:	22
6. Condition-Based Maintenance (CBM) Programs.....	23
6.1 Frequently Asked Questions:	23
7. Time-Based Versus Condition-Based Maintenance.....	25
7.1 Frequently Asked Questions:	25
8. Maximum Allowable Verification Intervals	31
8.1 Maintenance Tests.....	31
8.1.1 Table of Maximum Allowable Verification Intervals.....	31

8.1.2 Additional Notes for Tables 1-1 through 1-5, Table 3, and Table 4.....	33
8.1.3 Frequently Asked Questions:	34
8.2 Retention of Records.....	39
8.2.1 Frequently Asked Questions:	40
8.3 Basis for Table 1 Intervals	42
8.4 Basis for Extended Maintenance Intervals for Microprocessor Relays	43
9. Performance-Based Maintenance Process.....	45
9.1 Minimum Sample Size	46
9.2 Frequently Asked Questions:	49
10. Overlapping the Verification of Sections of the Protection System	60
10.1 Frequently Asked Questions:	60
11. Monitoring by Analysis of Fault Records	61
11.1 Frequently Asked Questions:	62
12. Importance of Relay Settings in Maintenance Programs	63
12.1 Frequently Asked Questions:	63
13. Self-Monitoring Capabilities and Limitations	66
13.1 Frequently Asked Questions:	67
14. Notification of Protection System or Automatic Reclosing Failures	68
15. Maintenance Activities	69
15.1 Protective Relays (Table 1-1)	69
15.1.1 Frequently Asked Questions:	69
15.2 Voltage & Current Sensing Devices (Table 1-3)	69
15.2.1 Frequently Asked Questions:	71
15.3 Control circuitry associated with protective functions (Table 1-5)	72
15.3.1 Frequently Asked Questions:	73

15.4 Batteries and DC Supplies (Table 1-4).....	75
15.4.1 Frequently Asked Questions:	76
15.5 Associated communications equipment (Table 1-2)	90
15.5.1 Frequently Asked Questions:	91
15.6 Alarms (Table 2)	94
15.6.1 Frequently Asked Questions:	95
15.7 Distributed UFLS and Distributed UVLS Systems (Table 3)	95
15.7.1 Frequently Asked Questions:	96
15.8 Automatic Reclosing (Table 4)	96
15.8.1 Frequently-asked Questions	96
15.9 Examples of Evidence of Compliance	99
15.9.1 Frequently Asked Questions:	101
References	102
Figures.....	104
Figure 1: Typical Transmission System.....	104
Figure 2: Typical Generation System	105
Figure 1 & 2 Legend – Components of Protection Systems	106
Appendix A.....	107
Appendix B	110
Protection System Maintenance Standard Drafting Team.....	110

1. Introduction and Summary

Note: This supplementary reference for PRC-005-6 is neither mandatory nor enforceable.

NERC currently has four Reliability Standards that are mandatory and enforceable within the jurisdiction of the ERO and address various aspects of maintenance and testing of Protection and Control Systems.

These standards are:

PRC-005-1b — Transmission and Generation Protection System Maintenance and Testing

PRC-008-0 — Underfrequency Load Shedding Equipment Maintenance Programs

PRC-011-0 — UVLS System Maintenance and Testing

PRC-017-0 — Special Protection System Maintenance and Testing

While these standards require that applicable entities have a maintenance program for Protection Systems, and that these entities must be able to demonstrate they are carrying out such a program, there are no specifics regarding the technical requirements for Protection System maintenance programs. Furthermore, FERC Order 693 directed additional modifications to the respective Protection System maintenance programs. PRC-005-3 will replace PRC-005-2 which combined and replaced PRC-005, PRC-008, PRC-011 and PRC-017. PRC-005-3 adds Automatic Reclosing to PRC-005-2. PRC-005-2 addressed these directed modifications and replaces PRC-005, PRC-008, PRC-011 and PRC-017.

FERC Order 758 further directed that maintenance of reclosing relays and sudden pressure relays that affect the reliable operation of the Bulk Power System be addressed. PRC-005-3 addresses this directive regarding reclosing relays, and, when approved, will supersede PRC-005-2. PRC-005-4 addresses this directive regarding sudden pressure relays and, when approved, will supersede PRC-005-3.

This document augments the Supplementary Reference and FAQ previously developed for PRC-005-2 by including discussion relevant to Automatic Reclosing added in PRC-005-3 and Sudden Pressure Relaying in PRC-005-4.

2. Need for Verifying Protection System Performance

Protective relays have been described as silent sentinels, and do not generally demonstrate their performance until a Fault or other power system problem requires that they operate to protect power system Elements, or even the entire Bulk Electric System (BES). Lacking Faults, switching operations or system problems, the Protection Systems may not operate, beyond static operation, for extended periods. A Misoperation— defined as --a false operation of a Protection System or a failure of the Protection System to operate, as designed, when needed--can result in equipment damage, personnel hazards, and wide-area Disturbances or unnecessary customer outages. Maintenance or testing programs are used to determine the performance and availability of Protection Systems.

Typically, utilities have tested Protection Systems at fixed time intervals, unless they had some incidental evidence that a particular Protection System was not behaving as expected. Testing practices vary widely across the industry. Testing has included system functionality, calibration of measuring devices, and correctness of settings. Typically, a Protection System must be visited at its installation site and, in many cases, removed from service for this testing.

Fundamentally, a Reliability Standard for Protection System Maintenance and Testing requires the performance of the maintenance activities that are necessary to detect and correct plausible age and service related degradation of the Protection System components, such that a properly built and commissioned Protection System will continue to function as designed over its service life.

Similarly station batteries, which are an important part of the station dc supply, are not called upon to provide instantaneous dc power to the Protection System until power is required by the Protection System to operate circuit breakers or interrupting devices to clear Faults or to isolate equipment.

2.1 Existing NERC Standards for Protection System Maintenance and Testing

For critical BES protection functions, NERC standards have required that each utility or asset owner define a testing program. The starting point is the existing Standard PRC-005-5, briefly restated as follows:

Purpose: To document and implement programs for the maintenance of all Protection Systems affecting the reliability of the Bulk Electric System (BES) so that these Protection Systems are kept in working order.

PRC-005-6 is not specific on where the boundaries of the Protection Systems lie. However, the definition of Protection System in the [Glossary of Terms](#) Used in NERC Reliability Standards (Glossary) indicates what must be included as a minimum.

At the beginning of the project to develop PRC-005-2, the definition of Protection System was:

Protective relays, associated communications Systems, voltage and current sensing devices, station batteries and dc control circuitry.

Applicability: Owners of generation and transmission Protection Systems.

Requirements: The owner shall have a documented maintenance program with test intervals. The owner must keep records showing that the maintenance was performed at the specified intervals.

2.2 Protection System Definition

The most recently approved definition of Protection Systems is:

- Protective relays which respond to electrical quantities,
- Communications systems necessary for correct operation of protective functions,
- Voltage and current sensing devices providing inputs to protective relays,
- Station dc supply associated with protective functions (including station batteries, battery chargers, and non-battery-based dc supply), and
- Control circuitry associated with protective functions through the trip coil(s) of the circuit breakers or other interrupting devices.

2.3 Applicability of New Protection System Maintenance Standards

The BES purpose is to transfer bulk power. The applicability language has been changed from the original PRC-005:

“...affecting the reliability of the Bulk Electric System (BES)...”

To the present language:

“...that are installed for the purpose of detecting Faults on BES Elements (lines, buses, transformers, etc.).”

The drafting team intends that this standard will be consistent with any future definition of the Bulk Electric System. There should be no ambiguity; if the Element is a BES Element, then the Protection System protecting that Element should then be included within this standard. If there is regional variation to the definition, then there will be a corresponding regional variation to the Protection Systems that fall under this standard.

There is no way for the Standard Drafting Team to know whether a specific 230KV line, 115KV line (even 69KV line), for example, should be included or excluded. Therefore, the team expressed the clear intent that the standard language should simply be applicable to Protection Systems for BES Elements.

The BES is a NERC defined term that, from time to time, may undergo revisions. Additionally, there may be regional variations that are allowed in the present and future definitions.¹ Refer to the applicable Regional Reliability Organization for any applicable allowed variations.

While this standard may undergo revisions in the future, this standard will not attempt to keep up with revisions to the NERC definition of BES, but, rather, simply make BES Protection Systems applicable.

¹ See the NERC Glossary of Terms for the present, in-force definition.

The Standard is applied to Generator Owners (GO) and Transmission Owners (TO) because GOs and TOs have BES equipment. The standard brings in Distribution Providers (DP) because, depending on the station configuration of a particular substation, there may be Protection System equipment installed at a non-transmission voltage level (Distribution Provider equipment) that is wholly or partially installed to protect the BES. PRC-005-4 would apply to this equipment. An example is underfrequency load-shedding, which is frequently applied in distribution systems to meet PRC-007-0.

PRC-005-2 replaced the existing PRC-005, PRC-008, PRC-011 and PRC-017. Much of the original language of those standards was carried forward whenever it was possible to continue the intent and avoid a conflict with FERC Order 693. For example, the original PRC-008 was constructed quite differently than the original PRC-005. The drafting team agrees with the intent of this and notes that distributed tripping schemes would have to exhibit multiple failures to trip before they would prove to be significant, as opposed to a single failure to trip of, for example, a transmission Protection System Bus Differential lock-out relay. While a substantial number of failures of these distribution breakers could be significant, the team concluded likely that distribution breakers are operated often only for Fault clearing duty; and, therefore, the distribution circuit breakers are operated at least as frequently as stipulated in any requirement in this standard.

Additionally, since PRC-005-2 replaced PRC-011, it will be important to distinguish between under-voltage Protection Systems that protect individual Loads and Protection Systems that are Undervoltage Load Shedding (UVLS) schemes that protect the BES. Any UVLS scheme that had been applicable under PRC-011 is now applicable under PRC-005-2. An example of an under-voltage load-shedding scheme that is not applicable to this standard is one in which the tripping action was intended to prevent low distribution voltage to a specific Load from a Transmission system that was intact except for the line that was out of service, as opposed to preventing a Cascading outage or Transmission system collapse.

It had been correctly noted that the devices needed for PRC-011 are the very same types of devices needed in PRC-005.

Thus, a standard written for Protection Systems of the BES can easily make the needed requirements for Protection Systems, and replace some other standards at the same time.

2.3.1 Frequently Asked Questions:

What exactly is the BES, or Bulk Electric System?

BES is the abbreviation for the defined term Bulk Electric System. BES is a term in the Glossary of Terms used in Reliability Standards, and is not being modified within this draft standard.

Why is Distribution Provider included within the Applicable Entities and as a responsible entity within several of the requirements? Wouldn't anyone having relevant Facilities be a Transmission Owner?

Depending on the station configuration of a particular substation, there may be Protection System equipment installed at a non-transmission voltage level (Distribution Provider equipment) that is wholly or partially installed to protect the BES. PRC-005-4 applies to this equipment. An example is underfrequency load-shedding, which is frequently applied well down into the distribution system to meet the requirements of PRC-007-0.

We have an under voltage load-shedding (UVLS) system in place that prevents one of our distribution substations from supplying extremely low voltage in the case of a specific transmission line outage. The transmission line is part of the BES. Does this mean that our UVLS system falls within this standard?

The situation, as stated, indicates that the tripping action was intended to prevent low distribution voltage to a specific Load from a Transmission System that was intact, except for the line that was out of service, as opposed to preventing Cascading outage or Transmission System Collapse. This standard is not applicable to this UVLS.

We have a UFLS or UVLS scheme that sheds the necessary Load through distribution-side circuit breakers and circuit reclosers. Do the trip-test requirements for circuit breakers apply to our situation?

No--Distributed tripping schemes would have to exhibit multiple failures to trip before they would prove to be significant, as opposed to a single failure to trip of, for example, a transmission Protection System bus differential lock-out relay. While many failures of these distribution breakers could add up to be significant, it is also believed that distribution breakers are operated often on just Fault clearing duty; and, therefore, the distribution circuit breakers are operated at least as frequently as any requirements that might have appeared in this standard.

We have a UFLS scheme that, in some locales, sheds the necessary Load through non-BES circuit breakers and, occasionally, even circuit switchers. Do the trip-test requirements for circuit breakers apply to our situation?

If your “non-BES circuit breaker” has been brought into this standard by the inclusion of UFLS requirements, and otherwise would not have been brought into this standard, then the answer is that there are no trip-test requirements. For these devices that are otherwise non-BES assets, these tripping schemes would have to exhibit multiple failures to trip before they would prove to be as significant as, for example, a single failure to trip of a transmission Protection System bus differential lock-out relay.

How does the "Facilities" section of "Applicability" track with the standards that will be retired once PRC-005-2 becomes effective?

In establishing PRC-005-2, the drafting team combined legacy standards PRC-005-1b, PRC-008-0, PRC-011-0, and PRC-017-0. The merger of the subject matter of these standards is reflected in Applicability 4.2.

The intent of the drafting team is that the legacy standards be reflected in PRC-005-2 as follows:

- Applicability of PRC-005-1b for Protection Systems relating to non-generator elements of the BES is addressed in 4.2.1;
- Applicability of PRC-008-0 for underfrequency load shedding systems is addressed in 4.2.2;
- Applicability of PRC-011-0 for undervoltage load shedding relays is addressed in 4.2.3;
- Applicability of PRC-017-0 for Remedial Action Schemes is addressed in 4.2.4;
- Applicability of PRC-005-1b for Protection Systems for BES generators is addressed in 4.2.5 and 4.2.6.

2.4 Applicable Relays

The Glossary definition has a Protection System including relays, dc supply, current and voltage sensing devices, dc control circuitry and associated communications circuits. The relays to which this standard applies are those protective relays that respond to electrical quantities and provide a trip output to trip coils, dc control circuitry or associated communications equipment. This definition extends to IEEE Device No. 86 (lockout relay) and IEEE Device No. 94 (tripping or trip-free relay), as these devices are tripping relays that respond to the trip signal of the protective relay that processed the signals from the current and voltage-sensing devices.

Relays that respond to non-electrical inputs or impulses (such as, but not limited to, vibration, seismic, thermal or gas accumulation) are not included.

Automatic Reclosing is addressed in PRC-005-3 by explicitly addressing them outside the definition of Protection System. The specific locations for applicable Automatic Reclosing are addressed in Applicability Section 4.2.7.

Sudden Pressure Relaying is addressed in PRC-005-4 by explicitly addressing them outside the definition of Protection System. The specific locations for applicable Sudden Pressure Relaying are addressed in Applicability Section 4.2.1, 4.2.5.2, 4.2.5.3, and 4.2.6.

2.4.1 Frequently Asked Questions:

Are power circuit reclosers, reclosing relays, closing circuits and auto-restoration schemes covered in this Standard?

Yes. Automatic Reclosing includes reclosing relays and the associated dc control circuitry. Section 4.2.7 of the Applicability specifically limits the applicable reclosing relays to:

4.2.7 Automatic Reclosing

4.2.7.1 Automatic Reclosing applied on the terminals of Elements connected to the BES bus located at generating plant substations where the total installed gross generating plant capacity is greater than the gross capacity of the largest BES generating unit within the Balancing Authority Area or, if a member of a Reserve Sharing Group, the largest generating unit within the Reserve Sharing Group.

4.2.7.2 Automatic Reclosing applied on the terminals of all BES Elements at substations one bus away from generating plants specified in Section 4.2.7.1 when the substation is less than 10 circuit-miles from the generating plant substation.

4.2.7.3 Automatic Reclosing applied as an integral part of an RAS specified in Section 4.2.4.

Further, Footnote 1 to Applicability Section 4.2.7 establishes that Automatic Reclosing addressed in 4.2.7.1 and 4.2.7.2 may be excluded if the equipment owner can demonstrate that a close-in three-phase fault present for twice the normal clearing time (capturing a minimum trip-close-trip time delay) does not result in a total loss of gross generation in the Interconnection exceeding the gross capacity of the largest relevant BES generating unit where the Automatic Reclosing is applied.

Additionally, Footnote 2 to Applicability Section 4.2.7.1 advises that the entity's PSMP needs to remain current regarding the applicability of Automatic Reclosing Components relative to the largest generating unit within the Balancing Authority Area or Reserve Sharing Group.

The Applicability as detailed above was recommended by the NERC System Analysis and Modeling Subcommittee (SAMS) after a lengthy review of the use of reclosing within the BES. SAMS concluded that automatic reclosing is largely implemented throughout the BES as an operating convenience, and that automatic reclosing mal-performance affects BES reliability only when the reclosing is part of a Remedial Action Schemes, or when premature autoreclosing has the potential to cause generating unit or plant instability. A technical report, “Considerations for Maintenance and Testing of Autoreclosing Schemes — November 2012”, is referenced in PRC-005-3 and provides a more detailed discussion of these concerns.

Why did the standard drafting team not include IEEE device numbers to describe Automatic Reclosing Relays?

The drafting team elected not to include IEEE device numbers to describe Automatic Reclosing because Automatic Reclosing component type could be a stand-alone electromechanical relay; or could be the 79 function within a microprocessor based multi-function relay.

What is synchronizing or synchronism check relay (Sync-Check - 25)?

A synchronizing device that produces an output that supervises closure of a circuit breaker between two circuits whose voltages are within prescribed limits of magnitude and within the prescribed phase angle. It may or may not include voltage or speed control. A sync-check relay permits the paralleling of two circuits that are within prescribed (usually wider) limits of voltage magnitude and phase angle.

How do I interpret Applicability Section 4.2.7 to determine applicability in the following examples:

At my generating plant substation, I have a total of 800 MW connected to one voltage level and 200 MW connected to another voltage level. How do I determine my gross capacity? Where do I consider Automatic Reclosing to be applicable?

Scenario number 1:

The 800 MW of generation is connected to a BES voltage level bus, the 200 MW is connected to a non-BES voltage level bus, and there is no connection between the two buses locally or within 10 circuit miles from the generating plant substation. The largest single unit in the BA area is 750 MW.

In this case, the total installed gross generating capacity would be 800 MW. The two units are essentially independent plants.

The BES voltage level bus is considered to be the bus to which the 800 MW of generation is connected. Any BES Automatic Reclosing at this location, as well as other locations within 10 circuit miles, is considered to be applicable because 800 MW exceeds the largest single unit in the BA area.

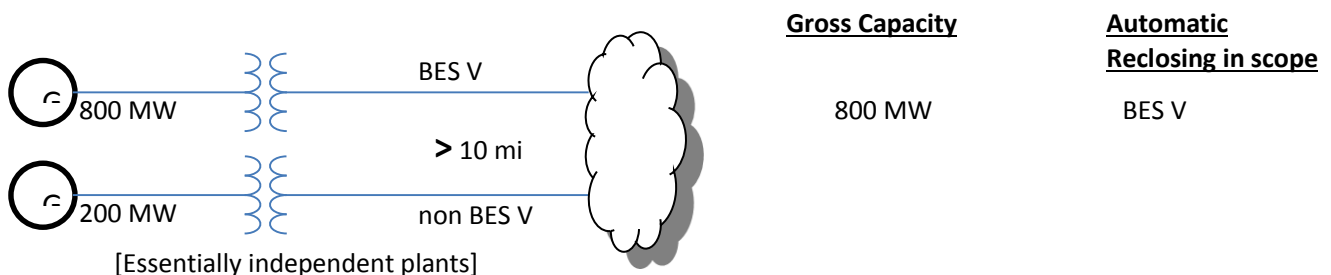

Scenario number 2:

The 800 MW of generation is connected to a BES voltage level bus, the 200 MW unit is connected to a non-BES voltage level bus, and there is a connection between the two buses locally or within 10 circuit miles from the generating plant substation. The largest single unit in the BA area is 750 MW.

In this case, reclosing into a fault on the BES system could impact the stability of the non-BES-connected generating units. Therefore, the total installed gross generating capacity would be 1000 MW.

The BES voltage level bus is considered to be the bus to which the 800 MW of generation is connected. Any BES Automatic Reclosing at this location, as well as other locations within 10 circuit miles, is considered to be applicable because total of 1000 MW exceeds the largest single unit in the BA area. However, the Automatic Reclosing on the non-BES voltage level bus is not applicable.

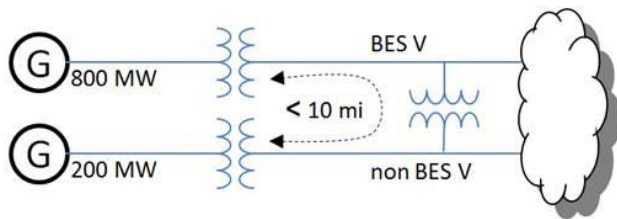

Gross Capacity

Automatic Reclosing in scope

1000 MW

BES V

Scenario number 3:

The 800 MW of generation is connected to a BES voltage level bus, the 200 MW unit is connected to a non-BES voltage level bus, and there is no connection between the two buses locally or within 10 circuit miles from the generating plant substation but the generating units connected at the BES voltage level do not operate independently of the units connected at the non BES voltage level (e.g., a combined cycle facility where 800 MW of combustion turbines are connected at a BES voltage level whose exhaust is used to power a 200 MW steam unit connected to a non BES voltage level. The largest single unit in the BA area is 750 MW.

In this case, the total installed gross generating capacity would be 1000 MW. Therefore, reclosing into a fault on the BES voltage level would result in a loss of the 800 MW combustion turbines and subsequently result in the loss of the 200 MW steam unit because of the loss of the heat source to its boiler.

The BES voltage level bus is considered to be the bus to which the 800 MW of generation is connected. Any BES Automatic Reclosing at this location, as well as other locations within 10 circuit miles, is considered to be applicable because total of 1000 MW exceeds the largest single unit in the BA area. However, the Automatic Reclosing on the non-BES voltage level bus is not applicable.

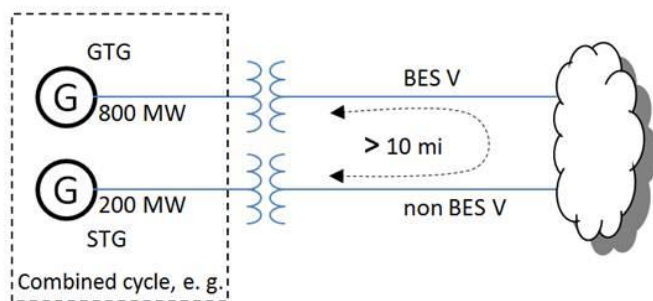

Gross Capacity

Automatic Reclosing in scope

1000 MW

BES V

Scenario 4

The 800 MW of generation is connected at 345 kV and the 200 MW is connected at 138 kV with an autotransformer at the generating plant substation connecting the two voltage levels. The largest single unit in the BA area is 900 MW.

In this case, the total installed gross generating capacity would be 1000 MW and section 4.2.7.1 would be applicable to both the 345 kV Automatic Reclosing Components and the 138 kV Automatic Reclosing Components, since the total capacity of 1000 MW is larger than the largest single unit in the BA area.

However, if the 345 kV and the 138 kV systems can be shown to be uncoupled such that the 138 kV reclosing relays will not affect the stability of the 345 kV generating units then the 138 kV Automatic Reclosing Components need not be included per section 4.2.7.1.

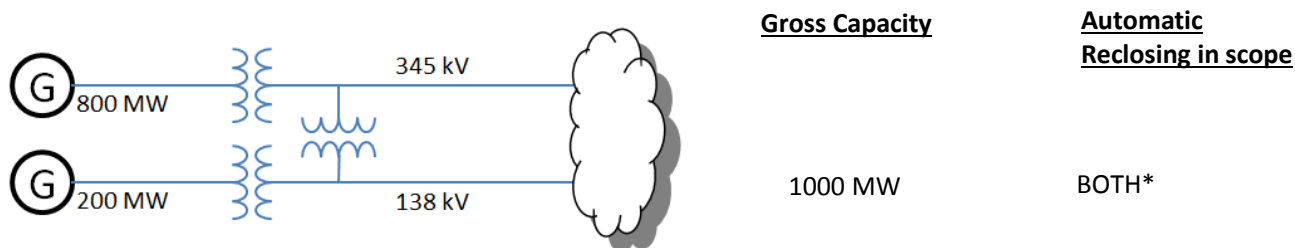

* The study detailed in Footnote 1 of the draft standard may eliminate the 138 kV Automatic Reclosing Components and/or the 345 kV Automatic Reclosing Components

Why does 4.2.7.2 specify "10 circuit miles"?

As noted in "Considerations for Maintenance and Testing of Autoreclosing Schemes — November 2012," transmission line impedance on the order of one mile away typically provides adequate impedance to prevent generating unit instability and a 10 mile threshold provides sufficient margin.

Should I use MVA or MW when determining the installed gross generating plant capacity?

Be consistent with the rating used by the Balancing Authority for the largest BES generating unit within their area.

What value should we use for generating plant capacity in 4.2.7.1?

Use the value reported to the Balance Authority for generating plant capacity for planning and modeling purposes. This can be nameplate or other values based on generating plant limitations such as boiler or turbine ratings.

What is considered to be "one bus away" from the generation?

The BES voltage level bus is considered to be the generating plant substation bus to which the generator step-up transformer is connected. "One bus away" is the next bus, connected by either a transmission line or transformer.

I use my protective relays only as sources of metered quantities and breaker status for SCADA and EMS through a substation distributed RTU or data concentrator to the control center. What are the maintenance requirements for the relays?

This standard addresses Protection Systems that are installed for the purpose of detecting Faults on BES Elements (e.g. lines, buses, transformers, etc.). Protective relays, providing only the functions mentioned in the question, are not included.

Are Reverse Power Relays installed on the low-voltage side of distribution banks considered to be components of "Protection Systems that are installed for the purpose of detecting Faults on BES Elements (lines, buses, transformers, etc.)?"

Reverse power relays are often installed to detect situations where the transmission source becomes de-energized and the distribution bank remains energized from a source on the low-voltage side of the transformer and the settings are calculated based on the charging current of the transformer from the low-voltage side. Although these relays may operate as a result of a fault on a BES element, they are not "installed for the purpose of detecting" these faults.

Why is the maintenance of Sudden Pressure Relaying being addressed in PRC-005-6?

Proper performance of Sudden Pressure Relaying supports the reliability of the BES because fault pressure relays can detect rapid changes in gas pressure, oil pressure, or oil flow that are indicative of faults within liquid-filled, wire-wound equipment such as turn-to-turn faults which may be undetected by Protection Systems. Additionally, Sudden Pressure Relaying can quickly detect faults and operate to limit damage to liquid-filled, wire-wound equipment.

What type of devices are classified as fault pressure relay?

There are three main types of fault pressure relays; rapid gas pressure rise, rapid oil pressure rise, and rapid oil flow devices.

Rapid gas pressure devices monitor the pressure in the space above the oil (or other liquid), and initiate tripping action for a rapid rise in gas pressure resulting from the rapid expansion of the liquid caused by a fault. The sensor is located in the gas space.

Rapid oil pressure devices monitor the pressure in the oil (or other liquid), and initiate tripping action for a rapid pressure rise caused by a fault. The sensor is located in the liquid.

Rapid oil flow devices, Buchholz) monitor the liquid flow between a transformer/reactor and its conservator. Normal liquid flow occurs continuously with ambient temperature changes and with internal heating from loading and does not operate the rapid oil flow device. However, when an internal arc occurs, a sudden expansion of liquid can be monitored as rapid liquid flow from the transformer into the conservator resulting in actuation of the rapid oil flow device.

Are sudden pressure relays that only initiate an alarm included in the scope of PRC-005-6?

No--the definition of Sudden Pressure Relaying specifies only those that trip an interrupting device(s) to isolate the equipment it is monitoring.

Are pressure relief devices included in the scope of PRC-005-6?

No--PRDs are not included in the Sudden Pressure Relaying definition.

Is Sudden Pressure Relaying installed on distribution transformers included in PRC-005-6?

No--Applicability 4.2.1, 4.2.5, and 4.2.6 explicitly describes what Sudden Pressure Relaying is included within the standard.

Are non-electrical sensing devices (other than fault pressure relays) such as low oil level or high winding temperatures included in PRC-005-6?

No--based on the SPCS technical document, "Sudden Pressure Relays and Other Devices that Respond to Non-Electrical Quantities – December 2013," the only applicable non-electrical sensing devices are Sudden Pressure Relays.

The standard specifically mentions auxiliary and lock-out relays. What is an auxiliary tripping relay?

An auxiliary relay, IEEE Device No. 94, is described in IEEE Standard C37.2-2008 as: "A device that functions to trip a circuit breaker, contactor, or equipment; to permit immediate tripping by other devices; or to prevent immediate reclosing of a circuit interrupter if it should open automatically, even though its closing circuit is maintained closed."

What is a lock-out relay?

A lock-out relay, IEEE Device No. 86, is described in IEEE Standard C37.2 as: "A device that trips and maintains the associated equipment or devices inoperative until it is reset by an operator, either locally or remotely."

3. Protection System and Automatic Reclosing Product Generations

The likelihood of failure and the ability to observe the operational state of a critical Protection System and Automatic Reclosing both depend on the technological generation of the relays, as well as how long they have been in service. Unlike many other transmission asset groups, protection and control systems have seen dramatic technological changes spanning several generations. During the past 20 years, major functional advances are primarily due to the introduction of microprocessor technology for power system devices, such as primary measuring relays, monitoring devices, control systems, and telecommunications equipment.

Modern microprocessor-based relays have six significant traits that impact a maintenance strategy:

- Self-monitoring capability - the processors can check themselves, peripheral circuits, and some connected substation inputs and outputs, such as trip coil continuity. Most relay users are aware that these relays have self-monitoring, but are not focused on exactly what internal functions are actually being monitored. As explained further below, every element critical to the Protection System must be monitored, or else verified periodically.
- Ability to capture Fault records showing how the Protection System responded to a Fault in its zone of protection, or to a nearby Fault for which it is required not to operate.
- Ability to meter currents and voltages, as well as status of connected circuit breakers, continuously during non-Fault times. The relays can compute values, such as MW and MVAR line flows, that are sometimes used for operational purposes, such as SCADA.
- Data communications via ports that provide remote access to all of the results of Protection System monitoring, recording and measurement.
- Ability to trip or close circuit breakers and switches through the Protection System outputs, on command from remote data communications messages, or from relay front panel button requests.
- Construction from electronic components, some of which have shorter technical life or service life than electromechanical components of prior Protection System generations.

There have been significant advances in the technology behind the other components of Protection Systems. Microprocessors are now a part of battery chargers, associated communications equipment, voltage and current-measuring devices, and even the control circuitry (in the form of software-latches replacing lock-out relays, etc.).

Any Protection System component can have self-monitoring and alarming capability, not just relays. Because of this technology, extended time intervals for maintenance and inspection can find their way into all components of the Protection System.

This standard also recognizes the distinct advantage of using advanced technology to justifiably defer or even eliminate traditional maintenance. Just as a hand-held calculator does not require routine testing and calibration, neither does a calculation buried in a microprocessor-based device that results in a “lock-out.” Thus, the software-latch 86 that replaces an electro-mechanical 86 does not require routine trip testing. Any trip circuitry associated with the “soft 86” would still need applicable verification activities performed, but the actual “86” does not have to be “electrically operated” or even toggled.

4. Definitions

Protection System Maintenance Program (PSMP) — An ongoing program by which Protection System, Automatic Reclosing and Sudden Pressure Relaying Components are kept in working order and proper operation of malfunctioning Components is restored. A maintenance program for a specific Component includes one or more of the following activities:

- Verify — Determine that the Component is functioning correctly.
- Monitor — Observe the routine in-service operation of the Component.
- Test — Apply signals to a Component to observe functional performance or output behavior, or to diagnose problems.
- Inspect — Examine for signs of Component failure, reduced performance and degradation.
- Calibrate — Adjust the operating threshold or measurement accuracy of a measuring element to meet the intended performance requirement.

Automatic Reclosing – Includes the following Components:

- Reclosing relay
- Supervisory relay(s) or function(s) – relay(s) or function(s) that perform voltage and/or sync check functions that enables or disables operation of the reclosing relay
- Voltage sensing devices associated with the supervisory relay(s)
- Control circuitry associated with the reclosing relay or supervisory relay(s)

Sudden Pressure Relaying – A system that trips an interrupting device(s) to isolate the equipment it is monitoring and includes the following Components:

- Fault pressure relay – a mechanical relay or device that detects rapid changes in gas pressure, oil pressure, or oil flow that are indicative of faults within liquid-filled, wire-wound equipment
- Control circuitry associated with a fault pressure relay

Unresolved Maintenance Issue – A deficiency identified during a maintenance activity that causes the component to not meet the intended performance, cannot be corrected during the maintenance interval, and requires follow-up corrective action.

Segment – Components of a consistent design standard, or a particular model or type from a single manufacturer that typically share other common elements. Consistent performance is expected across the entire population of a Segment. A Segment must contain at least sixty (60) individual Components.

Component Type –

- Any one of the five specific elements of a Protection System.
- Any one of the four specific elements of Automatic Reclosing.
- Any one of the two specific elements of Sudden Pressure Relaying.

Component – Any individual discrete piece of equipment included in a Protection System, Automatic Reclosing, or Sudden Pressure Relaying.

Countable Event – A failure of a Component requiring repair or replacement, any condition discovered during the maintenance activities in Tables 1-1 through 1-5, Table 3, Tables 4-1 through 4-3, and Table 5, which requires corrective action or a Protection System Misoperation attributed to hardware failure or calibration failure. Misoperations due to product design errors, software errors, relay settings different from specified settings, Protection System Component, Automatic Reclosing or Sudden Pressure Relaying configuration or application errors are not included in Countable Events.

4.1 Frequently Asked Questions:

Why does PRC-005-6 not specifically require maintenance and testing procedures, as reflected in the previous standard, PRC-005-1?

PRC-005-1 does not require detailed maintenance and testing procedures, but instead requires summaries of such procedures, and is not clear on what is actually required. PRC-005-6 requires a documented maintenance program, and is focused on establishing requirements rather than prescribing methodology to meet those requirements. Between the activities identified in the Tables 1-1 through 1-5, Table 2, Table 3, and Table 4 (collectively the “Tables”), and the various components of the definition established for a “Protection System Maintenance Program,” PRC-005-6 establishes the activities and time basis for a Protection System Maintenance Program to a level of detail not previously required.

Please clarify what is meant by “restore” in the definition of maintenance.

The description of “restore” in the definition of a Protection System Maintenance Program addresses corrective activities necessary to assure that the component is returned to working order following the discovery of its failure or malfunction. The Maintenance Activities specified in the Tables do not present any requirements related to Restoration; Requirement R5 of the standard does require that the entity “shall demonstrate efforts to correct any identified Unresolved Maintenance Issues.” Some examples of restoration (or correction of Unresolved Maintenance Issues) include, but are not limited to, replacement of capacitors in distance relays to bring them to working order; replacement of relays, or other Protection System components, to bring the Protection System to working order; upgrade of electromechanical or solid-state protective relays to microprocessor-based relays following the discovery of failed components. Restoration, as used in this context, is not to be confused with restoration rules as used in system operations. Maintenance activity necessarily includes both the detection of problems and the repairs needed to eliminate those problems. This standard does not identify all of the Protection System problems that must be detected and eliminated, rather it is the intent of this standard that an entity determines the necessary working order for their various devices, and keeps them in working order. If an equipment item is repaired or replaced, then the entity can restart the maintenance-time-interval-clock, if desired; however, the replacement of equipment does not remove any documentation requirements that would have been required to verify compliance with time-interval requirements. In other words, do not discard maintenance data that goes to verify your work.

The retention of documentation for new and/or replaced equipment provides evidence that the maintenance intervals have been compliant. For example, a long-range plan of upgrades might lead an entity to ignore required maintenance; retaining the evidence of prior

maintenance that existed before any retirements and upgrades proves compliance with the standard.

Please clarify what is meant by “...demonstrate efforts to correct an Unresolved Maintenance Issue...;” why not measure the completion of the corrective action?

Management of completion of the identified Unresolved Maintenance Issue is a complex topic that falls outside of the scope of this standard. There can be any number of supply, process and management problems that make setting repair deadlines impossible. The SDT specifically chose the phrase “demonstrate efforts to correct” (with guidance from NERC Staff) because of the concern that many more complex Unresolved Maintenance Issues might require greater than the remaining maintenance interval to resolve (and yet still be a “closed-end process”). For example, a problem might be identified on a VRLA battery during a six-month check. In instances such as one that requiring battery replacement as part of the long-term resolution, it is highly unlikely that the battery could be replaced in time to meet the six-calendar-month requirement for this maintenance activity. The SDT does not believe entities should be found in violation of a maintenance program requirement because of the inability to complete a remediation program within the original maintenance interval. The SDT does believe corrective actions should be timely, but concludes it would be impossible to postulate all possible remediation projects; and, therefore, impossible to specify bounding time frames for resolution of all possible Unresolved Maintenance Issues, or what documentation might be sufficient to provide proof that effective corrective action is being undertaken.

5. Time-Based Maintenance (TBM) Programs

Time-based maintenance is the process in which Protection System, Automatic Reclosing and Sudden Pressure Relaying Components are maintained or verified according to a time schedule. The scheduled program often calls for technicians to travel to the physical site and perform a functional test on Protection System components. However, some components of a TBM program may be conducted from a remote location—for example, tripping a circuit breaker by communicating a trip command to a microprocessor relay to determine if the entire Protection System tripping chain is able to operate the breaker. Similarly, all Protection System, and Sudden Pressure Relaying Components, can have the ability to remotely conduct tests, either on-command or routinely; the running of these tests can extend the time interval between hands-on maintenance activities.

5.1 Maintenance Practices

Maintenance and testing programs often incorporate the following types of maintenance practices:

- TBM – time-based maintenance – externally prescribed maximum maintenance or testing intervals are applied for components or groups of components. The intervals may have been developed from prior experience or manufacturers’ recommendations. The TBM verification interval can be based on a variety of factors, including experience of the particular asset owner, collective experiences of several asset owners who are members of a country or regional council, etc. The maintenance intervals are fixed and may range in number from months to years.

TBM can include review of recent power system events near the particular terminal. Operating records may verify that some portion of the Protection System has operated correctly since the last test occurred. If specific protection scheme components have demonstrated correct performance within specifications, the maintenance test time clock can be reset for those components.

- PBM – Performance-Based Maintenance - intervals are established based on analytical or historical results of TBM failure rates on a statistically significant population of similar components. Some level of TBM is generally followed. Statistical analyses accompanied by adjustments to maintenance intervals are used to justify continued use of PBM-developed extended intervals when test failures or in-service failures occur infrequently.
- CBM – condition-based maintenance – continuously or frequently reported results from non-disruptive self-monitoring of components demonstrate operational status as those components remain in service. Whatever is verified by CBM does not require manual testing, but taking advantage of this requires precise technical focus on exactly what parts are included as part of the self-diagnostics. While the term “Condition-Based-Maintenance” (CBM) is no longer used within the standard itself, it is important to note that the concepts of CBM are a part of the standard (in the form of extended time intervals through status-monitoring). These extended time intervals are only allowed (in the absence of PBM) if the condition of the device is continuously monitored (CBM). As a consequence of the “monitored-basis-time-intervals” existing within the standard, the

explanatory discussions within this Supplementary Reference concerned with CBM will remain in this reference and are discussed as CBM.

Microprocessor-based Protection System or Automatic Reclosing Components that perform continuous self-monitoring verify correct operation of most components within the device. Self-monitoring capabilities may include battery continuity, float voltages, unintentional grounds, the ac signal inputs to a relay, analog measuring circuits, processors and memory for measurement, protection, and data communications, trip circuit monitoring, and protection or data communications signals (and many, many more measurements). For those conditions, failure of a self-monitoring routine generates an alarm and may inhibit operation to avoid false trips. When internal components, such as critical output relay contacts, are not equipped with self-monitoring, they can be manually tested. The method of testing may be local or remote, or through inherent performance of the scheme during a system event.

The TBM is the overarching maintenance process of which the other types are subsets. Unlike TBM, PBM intervals are adjusted based on good or bad experiences. The CBM verification intervals can be hours, or even milliseconds between non-disruptive self-monitoring checks within or around components as they remain in service.

TBM, PBM, and CBM can be combined for individual components, or within a complete Protection System. The following diagram illustrates the relationship between various types of maintenance practices described in this section. In the Venn diagram, the overlapping regions show the relationship of TBM with PBM historical information and the inherent continuous monitoring offered through CBM.

This figure shows:

- Region 1: The TBM intervals that are increased based on known reported operational condition of individual components that are monitoring themselves.
- Region 2: The TBM intervals that are adjusted up or down based on results of analysis of maintenance history of statistically significant population of similar products that have been subject to TBM.
- Region 3: Optimal TBM intervals based on regions 1 and 2.

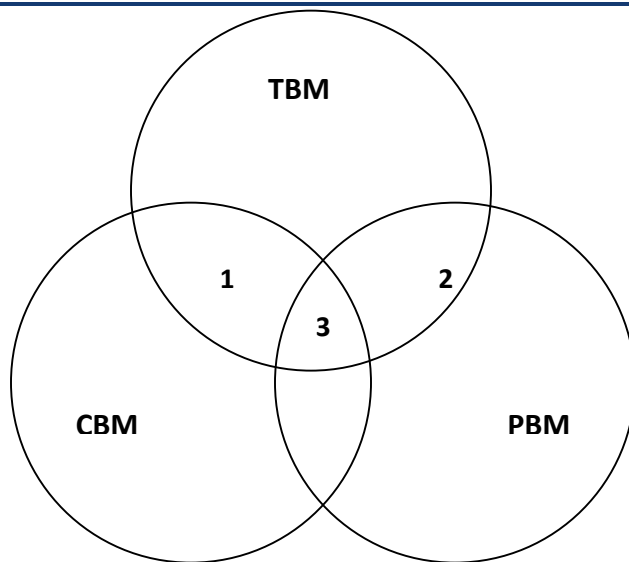

Relationship of time-based maintenance types

5.1.1 Frequently Asked Questions:

The standard seems very complicated, and is difficult to understand. Can it be simplified?

Because the standard is establishing parameters for condition-based Maintenance (Requirement R1) and Performance-Based Maintenance (Requirement R2), in addition to simple time-based Maintenance, it does appear to be complicated. At its simplest, an entity needs to ONLY perform time-based maintenance according to the unmonitored rows of the Tables. If an entity then wishes to take advantage of monitoring on its Protection System components and its available lengthened time intervals, then it may, as long as the component has the listed monitoring attributes. If an entity wishes to use historical performance of its Protection System components to perform Performance-Based Maintenance, then Requirement R2 applies.

Please see the following diagram, which provides a “flow chart” of the standard.

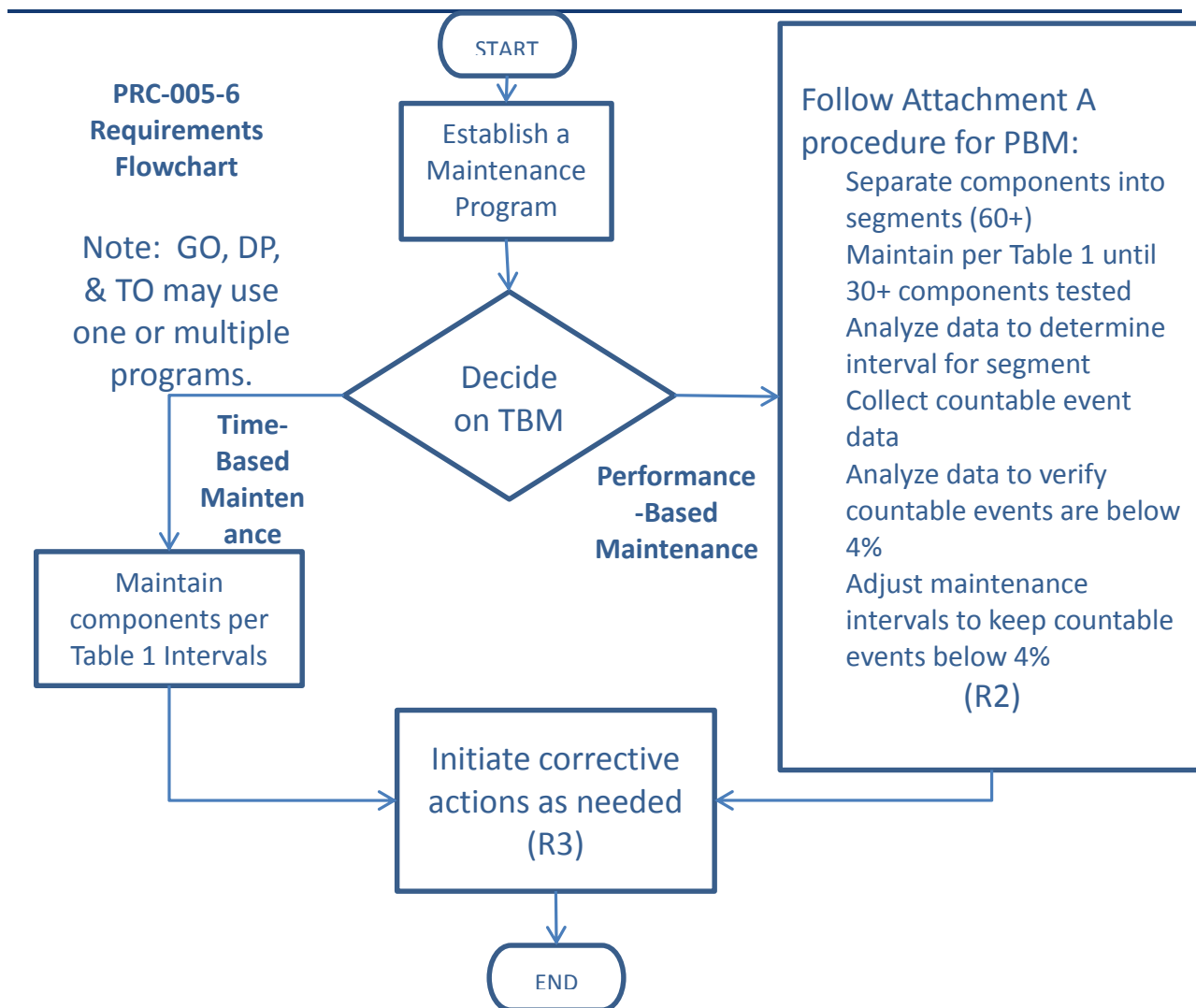

We have an electromechanical (unmonitored) relay that has a trip output to a lockout relay (unmonitored) which trips our transformer off-line by tripping the transformer’s high-side and low-side circuit breakers. What testing must be done for this system?

This system is made up of components that are all unmonitored. Assuming a time-based Protection System Maintenance Program schedule (as opposed to a Performance-Based maintenance program), each component must be maintained per the most frequent hands-on activities listed in the Tables.

5.2 Extending Time-Based Maintenance

All maintenance is fundamentally time-based. Default time-based intervals are commonly established to assure proper functioning of each component of the Protection System, when data on the reliability of the components is not available other than observations from time-based maintenance. The following factors may influence the established default intervals:

- If continuous indication of the functional condition of a component is available (from relays or chargers or any self-monitoring device), then the intervals may be extended, or manual testing may be eliminated. This is referred to as condition-based maintenance or

CBM. CBM is valid only for precisely the components subject to monitoring. In the case of microprocessor-based relays, self-monitoring may not include automated diagnostics of every component within a microprocessor.

- Previous maintenance history for a group of components of a common type may indicate that the maintenance intervals can be extended, while still achieving the desired level of performance. This is referred to as Performance-Based Maintenance, or PBM. It is also sometimes referred to as reliability-centered maintenance, or RCM; but PBM is used in this document.
- Observed proper operation of a component may be regarded as a maintenance verification of the respective component or element in a microprocessor-based device. For such an observation, the maintenance interval may be reset only to the degree that can be verified by data available on the operation. For example, the trip of an electromechanical relay for a Fault verifies the trip contact and trip path, but only through the relays in series that actually operated; one operation of this relay cannot verify correct calibration.

Excessive maintenance can actually decrease the reliability of the component or system. It is not unusual to cause failure of a component by removing it from service and restoring it. The improper application of test signals may cause failure of a component. For example, in electromechanical overcurrent relays, test currents have been known to destroy convolution springs.

In addition, maintenance usually takes the component out of service, during which time it is not able to perform its function. Cutout switch failures, or failure to restore switch position, commonly lead to protection failures.

5.2.1 Frequently Asked Questions:

If I show the protective device out of service while it is being repaired, then can I add it back as a new protective device when it returns? If not, my relay testing history would show that I was out of compliance for the last maintenance cycle.

The maintenance and testing requirements (R5) (in essence) state "...shall demonstrate efforts to correct identified Unresolved Maintenance Issues." The type of corrective activity is not stated; however, it could include repairs or replacements.

Your documentation requirements will increase, of course, to demonstrate that your device test failed and had corrective actions initiated. Your regional entity will likely request documentation showing the status of your corrective actions.

6. Condition-Based Maintenance (CBM) Programs

Condition-based maintenance is the process of gathering and monitoring the information available from modern microprocessor-based relays and other intelligent electronic devices (IEDs) that monitor Protection System or Automatic Reclosing elements. These devices generate monitoring information during normal operation, and the information can be assessed at a convenient location remote from the substation. The information from these relays and IEDs is divided into two basic types:

1. Information can come from background self-monitoring processes, programmed by the manufacturer, or by the user in device logic settings. The results are presented by alarm contacts or points, front panel indications, and by data communications messages.
2. Information can come from event logs, captured files, and/or oscillographic records for Faults and Disturbances, metered values, and binary input status reports. Some of these are available on the device front panel display, but may be available via data communications ports. Large files of Fault information can only be retrieved via data communications. These results comprise a mass of data that must be further analyzed for evidence of the operational condition of the Protection System.

Using these two types of information, the user can develop an effective maintenance program carried out mostly from a central location remote from the substation. This approach offers the following advantages:

Non-invasive Maintenance: The system is kept in its normal operating state, without human intervention for checking. This reduces risk of damage, or risk of leaving the system in an inoperable state after a manual test. Experience has shown that keeping human hands away from equipment known to be working correctly enhances reliability.

Virtually Continuous Monitoring: CBM will report many hardware failure problems for repair within seconds or minutes of when they happen. This reduces the percentage of problems that are discovered through incorrect relaying performance. By contrast, a hardware failure discovered by TBM may have been present for much of the time interval between tests, and there is a good chance that some devices will show health problems by incorrect operation before being caught in the next test round. The frequent or continuous nature of CBM makes the effective verification interval far shorter than any required TBM maximum interval. To use the extended time intervals available through Condition Based Maintenance, simply look for the rows in the Tables that refer to monitored items.

6.1 Frequently Asked Questions:

My microprocessor relays and dc circuit alarms are contained on relay panels in a 24-hour attended control room. Does this qualify as an extended time interval condition-based (monitored) system?

Yes, provided the station attendant (plant operator, etc.) monitors the alarms and other indications (comparable to the monitoring attributes) and reports them within the given time limits that are stated in the criteria of the Tables.

When documenting the basis for inclusion of components into the appropriate levels of monitoring, as per Requirement R1 (Part 1.2) of the standard, is it necessary to provide this documentation about the device by listing of every component and the specific monitoring attributes of each device?

No--While maintaining this documentation on the device level would certainly be permissible, it is not necessary. Global statements can be made to document appropriate levels of monitoring for the entire population of a component type or portion thereof.

For example, it would be permissible to document the conclusion that all BES substation dc supply battery chargers are monitored by stating the following within the program description:

“All substation dc supply battery chargers are considered monitored and subject to the rows for monitored equipment of Table 1-4 requirements, as all substation dc supply battery chargers are equipped with dc voltage alarms and ground detection alarms that are sent to the manned control center.”

Similarly, it would be acceptable to use a combination of a global statement and a device-level list of exclusions. Example:

“Except as noted below, all substation dc supply battery chargers are considered monitored and subject to the rows for monitored equipment of Table 1-4 requirements, as all substation dc supply battery chargers are equipped with dc voltage alarms and ground detection alarms that are sent to the manned control center. The dc supply battery chargers of Substation X, Substation Y, and Substation Z are considered unmonitored and subject to the rows for unmonitored equipment in Table 1-4 requirements, as they are not equipped with ground detection capability.”

Regardless whether this documentation is provided by device listing of monitoring attributes, by global statements of the monitoring attributes of an entire population of component types, or by some combination of these methods, it should be noted that auditors may request supporting drawings or other documentation necessary to validate the inclusion of the device(s) within the appropriate level of monitoring. This supporting background information need not be maintained within the program document structure, but should be retrievable if requested by an auditor.

7. Time-Based Versus Condition-Based Maintenance

Time-based and condition-based (or monitored) maintenance programs are both acceptable, if implemented according to technically sound requirements. Practical programs can employ a combination of time-based and condition-based maintenance. The standard requirements introduce the concept of optionally using condition monitoring as a documented element of a maintenance program.

The Federal Energy Regulatory Commission (FERC), in its Order Number 693 Final Rule, dated March 16, 2007 (18 CFR Part 40, Docket No. RM06-16-000) on Mandatory Reliability Standards for the Bulk-Power System, directed NERC to submit a modification to PRC-005-1b that includes a requirement that maintenance and testing of a Protection System must be carried out within a maximum allowable interval that is appropriate to the type of the Protection System and its impact on the reliability of the Bulk Power System. Accordingly, this Supplementary Reference Paper refers to the specific maximum allowable intervals in PRC-005-6. The defined time limits allow for longer time intervals if the maintained component is monitored.

A key feature of condition-based monitoring is that it effectively reduces the time delay between the moment of a protection failure and time the Protection System or Automatic Reclosing owner knows about it, for the monitored segments of the Protection System. In some cases, the verification is practically continuous--the time interval between verifications is minutes or seconds. Thus, technically sound, condition-based verification, meets the verification requirements of the FERC order even more effectively than the strictly time-based tests of the same system components.

The result is that:

This NERC standard permits utilities to use a technically sound approach and to take advantage of remote monitoring, data analysis, and control capabilities of modern Protection System and Automatic Reclosing Components to reduce the need for periodic site visits and invasive testing of components by on-site technicians. This periodic testing must be conducted within the maximum time intervals specified in the Tables of PRC-005-6.

7.1 Frequently Asked Questions:

What is a Calendar Year?

Calendar Year - January 1 through December 31 of any year. As an example, if an event occurred on June 17, 2009 and is on a "One Calendar Year Interval," the next event would have to occur on or before December 31, 2010.

Please provide an example of "4 Calendar Months".

If a maintenance activity is described as being needed every four Calendar Months then it is performed in a (given) month and due again four months later. For example a battery bank is inspected in month number 1 then it is due again before the end of the month number 5. And specifically consider that you perform your battery inspection on January 3, 2010 then it must be inspected again before the end of May. Another example could be that a four-month inspection

was performed in January is due in May, but if performed in March (instead of May) would still be due four months later therefore the activity is due again July. Basically every “four Calendar Months” means to add four months from the last time the activity was performed and perform the activity by the end of the fourth month.

Please provide an example of the unmonitored versus other levels of monitoring available?

An unmonitored Protection System has no monitoring and alarm circuits on the Protection System components. A Protection System component that has monitoring attributes but no alarm output connected is considered to be unmonitored.

A monitored Protection System or an individual monitored component of a Protection System has monitoring and alarm circuits on the Protection System components. The alarm circuits must alert, within 24 hours, a location wherein corrective action can be initiated. This location might be, but is not limited to, an Operations Center, Dispatch Office, Maintenance Center or even a portable SCADA system.

There can be a combination of monitored and unmonitored Protection Systems within any given scheme, substation or plant; there can also be a combination of monitored and unmonitored components within any given Protection System.

Example #1: A combination of monitored and unmonitored components within a given Protection System might be:

- A microprocessor relay with an internal alarm connected to SCADA to alert 24-hr staffed operations center; it has internal self-diagnosis and alarming. (monitored)
- Instrumentation transformers, with no monitoring, connected as inputs to that relay. (unmonitored)
- A vented Lead-Acid battery with a low voltage alarm for the station dc supply voltage and an unintentional grounds detection alarm connected to SCADA. (monitoring varies)
- A circuit breaker with a trip coil, and the trip circuit is not monitored. (unmonitored)

Given the particular components and conditions, and using Table 1 and Table 2, the particular components have maximum activity intervals of:

Every four calendar months, inspect:

- Electrolyte level (station dc supply voltage and unintentional ground detection is being maintained more frequently by the monitoring system).

Every 18 calendar months, verify/inspect the following:

- Battery bank ohmic values to station battery baseline (if performance tests are not opted)
- Battery charger float voltage
- Battery rack integrity
- Cell condition of all individual battery cells (where visible)
- Battery continuity
- Battery terminal connection resistance

-
- Battery cell-to-cell resistance (where available to measure)

Every six calendar years, perform/verify the following:

- Battery performance test (if internal ohmic tests or other measurements indicative of battery performance are not opted)
- Verify that each trip coil is able to operate the circuit breaker, interrupting device, or mitigating device
- For electromechanical lock-out relays, electrical operation of electromechanical trip

Every 12 calendar years, verify the following:

- Microprocessor relay settings are as specified
- Operation of the microprocessor's relay inputs and outputs that are essential to proper functioning of the Protection System
- Acceptable measurement of power System input values seen by the microprocessor protective relay
- Verify that current and voltage signal values are provided to the protective relays
- Protection System component monitoring for the battery system signals are conveyed to a location where corrective action can be initiated
- The microprocessor relay alarm signals are conveyed to a location where corrective action can be initiated
- Verify all trip paths in the control circuitry associated with protective functions through the trip coil(s) of the circuit breakers or other interrupting devices
- Auxiliary outputs that are in the trip path shall be maintained as detailed in Table 1-5 of the standard under the 'Unmonitored Control Circuitry Associated with Protective Functions' section'
- Auxiliary outputs not in a trip path (i.e., annunciation or DME input) are not required, by this standard, to be checked

Example #2: A combination of monitored and unmonitored components within a given Protection System might be:

- A microprocessor relay with integral alarm that is not connected to SCADA. (unmonitored)
- Current and voltage signal values, with no monitoring, connected as inputs to that relay. (unmonitored)
- A vented lead-acid battery with a low voltage alarm for the station dc supply voltage and an unintentional grounds detection alarm connected to SCADA. (monitoring varies)
- A circuit breaker with a trip coil, with no circuits monitored. (unmonitored)

Given the particular components and conditions, and using the Table 1 (Maximum Allowable Testing Intervals and Maintenance Activities) and Table 2 (Alarming Paths and Monitoring), the particular components have maximum activity intervals of:

Every four calendar months, inspect:

- Electrolyte level (station dc supply voltage and unintentional ground detection is being maintained more frequently by the monitoring system)

Every 18 calendar months, verify/inspect the following:

- Battery bank trending of ohmic values or other measurements indicative of battery performance to station battery baseline (if performance tests are not opted)
- Battery charger float voltage
- Battery rack integrity
- Cell condition of all individual battery cells (where visible)
- Battery continuity
- Battery terminal connection resistance
- Battery cell-to-cell resistance (where available to measure)

Every six calendar years, verify/perform the following:

- Verify operation of the relay inputs and outputs that are essential to proper functioning of the Protection System
- Verify acceptable measurement of power system input values as seen by the relays
- Verify that each trip coil is able to operate the circuit breaker, interrupting device, or mitigating device
- For electromechanical lock-out relays, electrical operation of electromechanical trip
- Battery performance test (if internal ohmic tests are not opted)

Every 12 calendar years, verify the following:

- Current and voltage signal values are provided to the protective relays
- Protection System component monitoring for the battery system signals are conveyed to a location where corrective action can be initiated
- All trip paths in the control circuitry associated with protective functions through the trip coil(s) of the circuit breakers or other interrupting devices
- Auxiliary outputs that are in the trip path shall be maintained, as detailed in Table 1-5 of the standard under the Unmonitored Control Circuitry Associated with Protective Functions" section
- Auxiliary outputs not in a trip path (i.e., annunciation or DME input) are not required, by this standard, to be checked

Example #3: A combination of monitored and unmonitored components within a given Protection System might be:

- A microprocessor relay with alarm connected to SCADA to alert 24-hr staffed operations center; it has internal self-diagnosis and alarms. (monitored)
- Current and voltage signal values, with monitoring, connected as inputs to that relay (monitored)

-
- Vented Lead-Acid battery without any alarms connected to SCADA (unmonitored)
 - Circuit breaker with a trip coil, with no circuits monitored (unmonitored)

Given the particular components, conditions, and using the Table 1 (Maximum Allowable Testing Intervals and Maintenance Activities) and Table 2 (Alarming Paths and Monitoring), the particular components shall have maximum activity intervals of:

Every four calendar months, verify/inspect the following:

- Station dc supply voltage
- For unintentional grounds
- Electrolyte level

Every 18 calendar months, verify/inspect the following:

- Battery bank trending of ohmic values or other measurements indicative of battery performance to station battery baseline (if performance tests are not opted)
- Battery charger float voltage
- Battery rack integrity
- Battery continuity
- Battery terminal connection resistance
- Battery cell-to-cell resistance (where available to measure)
- Condition of all individual battery cells (where visible)

Every six calendar years, perform/verify the following:

- Battery performance test (if internal ohmic tests or other measurements indicative of battery performance are not opted)
- Verify that each trip coil is able to operate the circuit breaker, interrupting device, or mitigating device
- For electromechanical lock-out relays, electrical operation of electromechanical trip

Every 12 calendar years, verify the following:

- The microprocessor relay alarm signals are conveyed to a location where corrective action can be taken
- Microprocessor relay settings are as specified
- Operation of the microprocessor's relay inputs and outputs that are essential to proper functioning of the Protection System
- Acceptable measurement of power system input values seen by the microprocessor protective relay
- Verify all trip paths in the control circuitry associated with protective functions through the trip coil(s) of the circuit breakers or other interrupting devices

-
- Auxiliary outputs that are in the trip path shall be maintained, as detailed in Table 1-5 of the standard under the Unmonitored Control Circuitry Associated with Protective Functions section
 - Auxiliary outputs not in a trip path (i.e. annunciation or DME input) are not required, by this standard, to be checked

Why do components have different maintenance activities and intervals if they are monitored?

The rationale supporting different activities and intervals for monitored equipment is to allow less frequent manual intervention when more information is known about the condition of Protection System components. Condition-Based Maintenance is a valuable asset to improve reliability.

Can all components in a Protection System be monitored?

No--For some components in a Protection System, monitoring will not be relevant. For example, a battery will always need some kind of inspection.

We have a 30-year-old oil circuit breaker with a red indicating lamp on the substation relay panel that is illuminated only if there is continuity through the breaker trip coil. There is no SCADA monitor or relay monitor of this trip coil. The line protection relay package that trips this circuit breaker is a microprocessor relay that has an integral alarm relay that will assert on a number of conditions that includes a loss of power to the relay. This alarm contact connects to our SCADA system and alerts our 24-hour operations center of relay trouble when the alarm contact closes. This microprocessor relay trips the circuit breaker only and does not monitor trip coil continuity or other things such as trip current. Are the components monitored or not? How often must I perform maintenance?

The protective relay is monitored and can be maintained every 12 years, or when an Unresolved Maintenance Issue arises. The control circuitry can be maintained every 12 years. The circuit breaker trip coil(s) has to be electrically operated at least once every six years.

What is a mitigating device?

A mitigating device is the device that acts to respond as directed by a Remedial Action Schemes. It may be a breaker, valve, distributed control system, or any variety of other devices. This response may include tripping, closing, or other control actions.

8. Maximum Allowable Verification Intervals

The maximum allowable testing intervals and maintenance activities show how CBM with newer device types can reduce the need for many of the tests and site visits that older Protection System components require. As explained below, there are some sections of the Protection System that monitoring or data analysis may not verify. Verifying these sections of the Protection System or Automatic Reclosing requires some persistent TBM activity in the maintenance program. However, some of this TBM can be carried out remotely—for example, exercising a circuit breaker through the relay tripping circuits using the relay remote control capabilities can be used to verify function of one tripping path and proper trip coil operation, if there has been no Fault or routine operation to demonstrate performance of relay tripping circuits.

8.1 Maintenance Tests

Periodic maintenance testing is performed to ensure that the protection and control system is operating correctly after a time period of field installation. These tests may be used to ensure that individual components are still operating within acceptable performance parameters - this type of test is needed for components susceptible to degraded or changing characteristics due to aging and wear. Full system performance tests may be used to confirm that the total Protection System functions from measurement of power system values, to properly identifying Fault characteristics, to the operation of the interrupting devices.

8.1.1 Table of Maximum Allowable Verification Intervals

Table 1 (collectively known as Table 1, individually called out as Tables 1-1 through 1-5), Table 2, Table 3, Table 4-1 through Table 4-3, and Table 5 in the standard specify maximum allowable verification intervals for various generations of Protection Systems, Automatic Reclosing and Sudden Pressure Relaying and categories of equipment that comprise these systems. The right column indicates maintenance activities required for each category.

The types of components are illustrated in [Figures 1](#) and [2](#) at the end of this paper. Figure 1 shows an example of telecommunications-assisted transmission Protection System comprising substation equipment at each terminal and a telecommunications channel for relaying between the two substations. [Figure 2](#) shows an example of a generation Protection System. The various sub-systems of a Protection System that need to be verified are shown.

Non-distributed UFLS, UVLS, and RAS are additional categories of Table 1 that are not illustrated in these figures. Non-distributed UFLS, UVLS and RAS all use identical equipment as Protection Systems in the performance of their functions; and, therefore, have the same maintenance needs.

Distributed UFLS and UVLS Systems, which use local sensing on the distribution System and trip co-located non-BES interrupting devices, are addressed in Table 3 with reduced maintenance activities.

While it is easy to associate protective relays to multiple levels of monitoring, it is also true that most of the components that can make up a Protection System can also have technological advancements that place them into higher levels of monitoring.

To use the Maintenance Activities and Intervals Tables from PRC-005-6:

-
- First find the Table associated with your component. The tables are arranged in the order of mention in the definition of Protection System;
 - Table 1-1 is for protective relays,
 - Table 1-2 is for the associated communications systems,
 - Table 1-3 is for current and voltage sensing devices,
 - Table 1-4 is for station dc supply and
 - Table 1-5 is for control circuits.
 - Table 2, is for alarms; this was broken out to simplify the other tables.
 - Table 3 is for components which make-up distributed UFLS and UVLS Systems.
 - Table 4 is for Automatic Reclosing.
 - Table 5 is for Sudden Pressure Relaying.
 - Next, look within that table for your device and its degree of monitoring. The Tables have different hands-on maintenance activities prescribed depending upon the degree to which you monitor your equipment. Find the maintenance activity that applies to the monitoring level that you have on your piece of equipment.
 - This Maintenance activity is the minimum maintenance activity that must be documented.
 - If your Performance-Based Maintenance (PBM) plan requires more activities, then you must perform and document to this higher standard. (Note that this does not apply unless you utilize PBM.)
 - After the maintenance activity is known, check the maximum maintenance interval; this time is the maximum time allowed between hands-on maintenance activity cycles of this component.
 - If your Performance-Based Maintenance plan requires activities more often than the Tables maximum, then you must perform and document those activities to your more stringent standard. (Note that this does not apply unless you utilize PBM.)
 - Any given component of a Protection System can be determined to have a degree of monitoring that may be different from another component within that same Protection System. For example, in a given Protection System it is possible for an entity to have a monitored protective relay and an unmonitored associated communications system; this combination would require hands-on maintenance activity on the relay at least once every 12 years and attention paid to the communications system as often as every four months.
 - An entity does not have to utilize the extended time intervals made available by this use of condition-based monitoring. An easy choice to make is to simply utilize the unmonitored level of maintenance made available in each of the Tables. While the maintenance activities resulting from this choice would require more maintenance man-hours, the maintenance requirements may be simpler to document and the resulting maintenance plans may be easier to create.

For each Protection System Component, Table 1 shows maximum allowable testing intervals for the various degrees of monitoring. For each Automatic Reclosing Component, Table 4 shows maximum allowable testing intervals for the various degrees of monitoring. These degrees of monitoring, or levels, range from the legacy unmonitored through a system that is more comprehensively monitored.

It has been noted here that an entity may have a PSMP that is more stringent than PRC-005-6. There may be any number of reasons that an entity chooses a more stringent plan than the minimums prescribed within PRC-005-6, most notable of which is an entity using performance based maintenance methodology.

If an entity has a Performance-Based Maintenance program, then that plan must be followed, even if the plan proves to be more stringent than the minimums laid out in the Tables.

If an entity has a Time-Based Maintenance program and the PSMP is more stringent than PRC-005-6, they will only be audited in accordance with the standard (minimum maintenance activities and maximum maintenance intervals prescribed within Tables 1-1 through 1-5, Table 2, Table 3, Table 4-1 through 4-3, and Table 5).

8.1.2 Additional Notes for Tables 1-1 through 1-5, Table 3, and Table 4

1. For electromechanical relays, adjustment is required to bring measurement accuracy within the tolerance needed by the asset owner. Microprocessor relays with no remote monitoring of alarm contacts, etc., are unmonitored relays and need to be verified within the Table interval as other unmonitored relays but may be verified as functional by means other than testing by simulated inputs.
2. Microprocessor relays typically are specified by manufacturers as not requiring calibration, but acceptable measurement of power system input values must be verified (verification of the Analog to Digital [A/D] converters) within the Table intervals. The integrity of the digital inputs and outputs that are used as protective functions must be verified within the Table intervals.
3. Any Phasor Measurement Unit (PMU) function whose output is used in a Protection System or RAS (as opposed to a monitoring task) must be verified as a component in a Protection System.
4. In addition to verifying the circuitry that supplies dc to the Protection System, the owner must maintain the station dc supply. The most widespread station dc supply is the station battery and charger. Unlike most Protection System components, physical inspection of station batteries for signs of component failure, reduced performance, and degradation are required to ensure that the station battery is reliable enough to deliver dc power when required. IEEE Standards 450, 1188, and 1106 for vented lead-acid, valve-regulated lead-acid, and nickel-cadmium batteries, respectively (which are the most commonly used substation batteries on the NERC BES) have been developed as an important reference source of maintenance recommendations. The Protection System owner might want to follow the guidelines in the applicable IEEE recommended practices for battery maintenance and testing, especially if the battery in question is used for application requirements in addition to the protection and control demands covered under this standard. However, the Standard Drafting Team has tailored the battery maintenance and

testing guidelines in PRC-005-6 for the Protection System owner which are application specific for the BES Facilities. While the IEEE recommendations are all encompassing, PRC-005-6 is a more economical approach while addressing the reliability requirements of the BES.

5. Aggregated small entities might distribute the testing of the population of UFLS/UVLS systems, and large entities will usually maintain a portion of these systems in any given year. Additionally, if relatively small quantities of such systems do not perform properly, it will not affect the integrity of the overall program. Thus, these distributed systems have decreased requirements as compared to other Protection Systems.
6. Voltage and current sensing device circuit input connections to the Protection System relays can be verified by (but not limited to) comparison of measured values on live circuits or by using test currents and voltages on equipment out of service for maintenance. The verification process can be automated or manual. The values should be verified to be as expected (phase value and phase relationships are both equally important to verify).
7. “End-to-end test,” as used in this Supplementary Reference, is any testing procedure that creates a remote input to the local communications-assisted trip scheme. While this can be interpreted as a GPS-type functional test, it is not limited to testing via GPS. Any remote scheme manipulation that can cause action at the local trip path can be used to functionally-test the dc control circuitry. A documented Real-time trip of any given trip path is acceptable in lieu of a functional trip test. It is possible, with sufficient monitoring, to be able to verify each and every parallel trip path that participated in any given dc control circuit trip. Or another possible solution is that a single trip path from a single monitored relay can be verified to be the trip path that successfully tripped during a Real-time operation. The variations are only limited by the degree of engineering and monitoring that an entity desires to pursue.
8. A/D verification may use relay front panel value displays, or values gathered via data communications. Groupings of other measurements (such as vector summation of bus feeder currents) can be used for comparison if calibration requirements assure acceptable measurement of power system input values.
9. Notes 1-8 attempt to describe some testing activities; they do not represent the only methods to achieve these activities, but rather some possible methods. Technological advances, ingenuity and/or industry accepted techniques can all be used to satisfy maintenance activity requirements; the standard is technology- and method-neutral in most cases.

8.1.3 Frequently Asked Questions:

What is meant by "Verify that settings are as specified" maintenance activity in Table 1-1?

Verification of settings is an activity directed mostly towards microprocessor- based relays. For relay maintenance departments that choose to test microprocessor-based relays in the same manner as electromechanical relays are tested, the testing process sometimes requires that some specific functions be disabled. Later tests might enable the functions previously disabled, but perhaps still other functions or logic statements were then masked out. It is

imperative that, when the relay is placed into service, the settings in the relay be the settings that were intended to be in that relay or as the standard states “...settings are as specified.”

Many of the microprocessor-based relays available today have software tools which provide this functionality and generate reports for this purpose.

For evidence or documentation of this requirement, a simple recorded acknowledgement that the settings were checked to be as specified is sufficient.

The drafting team was careful not to require “...that the relay settings be correct...” because it was believed that this might then place a burden of proof that the specified settings would result in the correct intended operation of the interrupting device. While that is a noble intention, the measurable proof of such a requirement is immense. The intent is that settings of the component be as specified at the conclusion of maintenance activities, whether those settings may have “drifted” since the prior maintenance or whether changes were made as part of the testing process.

Are electromechanical relays included in the "Verify that settings are as specified" maintenance activity in Table 1-1?

Verification of settings is an activity directed towards the application of protection related functions of microprocessor based relays. Electromechanical relays require calibration verification by voltage and/or current injection; and, thus, the settings are verified during calibration activity. In the example of a time-overcurrent relay, a minor deviation in time dial, versus the settings, may be acceptable, as long as the relay calibration is within accepted tolerances at the injected current amplitudes. A major deviation may require further investigation, as it could indicate a problem with the relay or an incorrect relay style for the application.

The verification of phase current and voltage measurements by comparison to other quantities seems reasonable. How, though, can I verify residual or neutral currents, or 3V0 voltages, by comparison, when my system is closely balanced?

Since these inputs are verified at commissioning, maintenance verification requires ensuring that phase quantities are as expected and that 3IO and 3V0 quantities appear equal to or close to 0.

These quantities also may be verified by use of oscillographic records for connected microprocessor relays as recorded during system Disturbances. Such records may compare to similar values recorded at other locations by other microprocessor relays for the same event, or compared to expected values (from short circuit studies) for known Fault locations.

What does this Standard require for testing an auxiliary tripping relay?

Table 1 and Table 3 requires that a trip test must verify that the auxiliary tripping relay(s) and/or lockout relay(s) which are directly in a trip path from the protective relay to the interrupting device trip coil operate(s) electrically. Auxiliary outputs not in a trip path (i.e. annunciation or DME input) are not required, by this standard, to be checked.

Do I have to perform a full end-to-end test of a Remedial Action Schemes?

No--all portions of the RAS need to be maintained, and the portions must overlap, but the overall RAS does not need to have a single end-to-end test. In other words it may be tested in piecemeal fashion provided all of the pieces are verified.

What about RAS interfaces between different entities or owners?

As in all of the Protection System requirements, RAS segments can be tested individually, thus minimizing the need to accommodate complex maintenance schedules.

What do I have to do if I am using a phasor measurement unit (PMU) as part of a Protection System or Remedial Action Schemes?

Any Phasor Measurement Unit (PMU) function whose output is used in a Protection System or Remedial Action Schemes (as opposed to a monitoring task) must be verified as a component in a Protection System.

How do I maintain a Remedial Action Schemes or relay sensing for non-distributed UFLS or UVLS Systems?

Since components of the RAS, UFLS and UVLS are the same types of components as those in Protection Systems, then these components should be maintained like similar components used for other Protection System functions. In many cases the devices for RAS, UFLS and UVLS are also used for other protective functions. The same maintenance activities apply with the exception that distributed systems (UFLS and UVLS) have fewer dc supply and control circuitry maintenance activity requirements.

For the testing of the output action, verification may be by breaker tripping, but may be verified in overlapping segments. For example, an RAS that trips a remote circuit breaker might be tested by testing the various parts of the scheme in overlapping segments. Another method is to document the Real-time tripping of an RAS scheme should that occur. Forced trip tests of circuit breakers (etc.) that are a part of distributed UFLS or UVLS schemes are not required.

The established maximum allowable intervals do not align well with the scheduled outages for my power plant. Can I extend the maintenance to the next scheduled outage following the established maximum interval?

No--you must complete your maintenance within the established maximum allowable intervals in order to be compliant. You will need to schedule your maintenance during available outages to complete your maintenance as required, even if it means that you may do protective relay maintenance more frequently than the maximum allowable intervals. The maintenance intervals were selected with typical plant outages, among other things, in mind.

If I am unable to complete the maintenance, as required, due to a major natural disaster (hurricane, earthquake, etc.), how will this affect my compliance with this standard?

The Sanction Guidelines of the North American Electric Reliability Corporation, effective January 15, 2008, provides that the Compliance Monitor will consider extenuating circumstances when considering any sanctions.

What if my observed testing results show a high incidence of out-of-tolerance relays; or, even worse, I am experiencing numerous relay Misoperations due to the relays being out-of-tolerance?

The established maximum time intervals are mandatory only as a not-to-exceed limitation. The establishment of a maximum is measurable. But any entity can choose to test some or all of their Protection System components more frequently (or to express it differently, exceed the minimum requirements of the standard). Particularly if you find that the maximum intervals in the standard do not achieve your expected level of performance, it is understandable that you would maintain the related equipment more frequently. A high incidence of relay Misoperations is in no one's best interest.

We believe that the four-month interval between inspections is unnecessary. Why can we not perform these inspections twice per year?

The Standard Drafting Team, through the comment process, has discovered that routine monthly inspections are not the norm. To align routine station inspections with other important inspections, the four-month interval was chosen. In lieu of station visits, many activities can be accomplished with automated monitoring and alarming.

Our maintenance plan calls for us to perform routine protective relay tests every 3 years. If we are unable to achieve this schedule, but we are able to complete the procedures in less than the maximum time interval, then are we in or out of compliance?

According to Requirement R3, if you have a time-based maintenance program, then you will be in violation of the standard only if you exceed the maximum maintenance intervals prescribed in the Tables. According to Requirement R4, if your device in question is part of a Performance-Based Maintenance program, then you will be in violation of the standard if you fail to meet your PSMP, even if you do not exceed the maximum maintenance intervals prescribed in the Tables. The intervals in the Tables are associated with TBM and CBM; Attachment A is associated with PBM.

Please provide a sample list of devices or systems that must be verified in a generator, generator step-up transformer, generator connected station service or generator connected excitation transformer to meet the requirements of this maintenance standard.

Examples of typical devices and systems that may directly trip the generator, or trip through a lockout relay, may include, but are not necessarily limited to:

- Fault protective functions, including distance functions, voltage-restrained overcurrent functions, or voltage-controlled overcurrent functions
- Loss-of-field relays
- Volts-per-hertz relays
- Negative sequence overcurrent relays
- Over voltage and under voltage protection relays
- Stator-ground relays
- Communications-based Protection Systems such as transfer-trip systems
- Generator differential relays

-
- Reverse power relays
 - Frequency relays
 - Out-of-step relays
 - Inadvertent energization protection
 - Breaker failure protection

For generator step-up, generator-connected station service transformers, or generator connected excitation transformers, operation of any of the following associated protective relays frequently would result in a trip of the generating unit; and, as such, would be included in the program:

- Transformer differential relays
- Neutral overcurrent relay
- Phase overcurrent relays

Relays which trip breakers serving station auxiliary Loads such as pumps, fans, or fuel handling equipment, etc., need not be included in the program, even if the loss of the those Loads could result in a trip of the generating unit. Furthermore, relays which provide protection to secondary unit substation (SUS) or low switchgear transformers and relays protecting other downstream plant electrical distribution system components are not included in the scope of this program, even if a trip of these devices might eventually result in a trip of the generating unit. For example, a thermal overcurrent trip on the motor of a coal-conveyor belt could eventually lead to the tripping of the generator, but it does not cause the trip.

In the case where a plant does not have a generator connected station service transformer such that it is normally fed from a system connected station service transformer, is it still the drafting team’s intent to exclude the Protection Systems for these system connected auxiliary transformers from scope even when the loss of the normal (system connected) station service transformer will result in a trip of a BES generating Facility?

The SDT does not intend that the system-connected station service transformers be included in the Applicability. The generator-connected station service transformers and generator connected excitation transformers are often connected to the generator bus directly without an interposing breaker; thus, the Protection Systems on these transformers will trip the generator as discussed in 4.2.5.1.

What is meant by "verify operation of the relay inputs and outputs that are essential to proper functioning of the Protection System?"

Any input or output (of the relay) that “affects the tripping” of the breaker is included in the scope of I/O of the relay to be verified. By “affects the tripping,” one needs to realize that sometimes there are more inputs and outputs than simply the output to the trip coil. Many important protective functions include things like breaker fail initiation, zone timer initiation and sometimes even 52a/b contact inputs are needed for a protective relay to correctly operate.

Each input should be “picked up” or “turned on and off” and verified as changing state by the microprocessor of the relay. Each output should be “operated” or “closed and opened” from the microprocessor of the relay and the output should be verified to change state on the output

terminals of the relay. One possible method of testing inputs of these relays is to “jumper” the needed dc voltage to the input and verify that the relay registered the change of state.

Electromechanical lock-out relays (86) (used to convey the tripping current to the trip coils) need to be electrically operated to prove the capability of the device to change state. These tests need to be accomplished at least every six years, unless PBM methodology is applied.

The contacts on the 86 or auxiliary tripping relays (94) that change state to pass on the trip current to a breaker trip coil need only be checked every 12 years with the control circuitry.

What is the difference between a distributed UFLS/UVLS and a non-distributed UFLS/UVLS scheme?

A distributed UFLS or UVLS scheme contains individual relays which make independent Load shed decisions based on applied settings and localized voltage and/or current inputs. A distributed scheme may involve an enable/disable contact in the scheme and still be considered a distributed scheme. A non-distributed UFLS or UVLS scheme involves a system where there is some type of centralized measurement and Load shed decision being made. A non-distributed UFLS/UVLS scheme is considered similar to an RAS scheme and falls under Table 1 for maintenance activities and intervals.

8.2 Retention of Records

PRC-005-1 describes a reporting or auditing cycle of one year and retention of records for three years. However, with a three-year retention cycle, the records of verification for a Protection System might be discarded before the next verification, leaving no record of what was done if a Misoperation or failure is to be analyzed.

PRC-005-6 corrects this by requiring:

The Transmission Owner, Generator Owner, and Distribution Provider shall each keep data or evidence to show compliance as identified below unless directed by its Compliance Enforcement Authority to retain specific evidence for a longer period of time as part of an investigation.

For Requirement R1, the Transmission Owner, Generator Owner, and Distribution Provider shall each keep its current dated Protection System Maintenance Program, as well as any superseded versions since the preceding compliance audit, including the documentation that specifies the type of maintenance program applied for each Protection System, Automatic Reclosing, or Sudden Pressure Relaying Component Type.

For Requirement R2, Requirement R3, and Requirement R4, in cases where the interval of the maintenance activity is longer than the audit cycle, the Transmission Owner, Generator Owner, and Distribution Provider shall each keep documentation of the most recent performance of that maintenance activity for the Protection System, Automatic Reclosing, or Sudden Pressure Relaying Component. In cases where the interval of the maintenance activity is shorter than the audit cycle, documentation of all performances (in accordance with the tables) of that maintenance activity for the Protection System, Automatic Reclosing, or Sudden Pressure Relaying Component since the previous scheduled audit date shall be retained.

For Requirement R5 the Transmission Owner, Generator Owner, and Distribution Provider shall each keep documentation of Unresolved Maintenance Issues identified by the entity since the last audit, including all that were resolved since the last audit.

This requirement assures that the documentation shows that the interval between maintenance cycles correctly meets the maintenance interval limits. The requirement is actually alerting the industry to documentation requirements already implemented by audit teams. Evidence of compliance bookending the interval shows interval accomplished instead of proving only your planned interval.

The SDT is aware that, in some cases, the retention period could be relatively long. But, the retention of documents simply helps to demonstrate compliance.

8.2.1 Frequently Asked Questions:

Please clarify the data retention requirements.

The data retention requirements are intended to allow the availability of maintenance records to demonstrate that the time intervals in your maintenance plan were upheld.

<u>Maximum Maintenance Interval</u>	<u>Data Retention Period</u>
4 Months, 6 Months, 18 Months, or 3 Years	All activities since previous audit
6 Years	All activities since previous audit (assuming a 6 year audit cycle) or most recent performance (assuming 3 year audit cycle), whichever is longer
12 Year	All activities from the most recent performance

If an entity prefers to utilize Performance-Based Maintenance, then statistical data may be retained for extended periods to assist with future adjustments in time intervals.

If an equipment item is replaced, then the entity can restart the maintenance-time-interval-clock if desired; however, the replacement of equipment does not remove any documentation requirements that would have been required to verify compliance with time-interval requirements. In other words, do not discard maintenance data that goes to verify your work.

The retention of documentation for new and/or replaced equipment is all about proving that the maintenance intervals had been in compliance. For example, a long-range plan of upgrades might lead an entity to ignore required maintenance; retaining the evidence of prior maintenance that existed before any retirements and upgrades proves compliance with the standard.

What does this Maintenance Standard say about commissioning? Is it necessary to have documentation in your maintenance history of the completion of commission testing?

This standard does not establish requirements for commission testing. Commission testing includes all testing activities necessary to conclude that a Facility has been built in accordance with design. While a thorough commission testing program would include, either directly or indirectly, the verification of all those Protection System attributes addressed by the

maintenance activities specified in the Tables of PRC-005-6, verification of the adequacy of initial installation necessitates the performance of testing and inspections that go well beyond these routine maintenance activities. For example, commission testing might set baselines for future tests; perform acceptance tests and/or warranty tests; utilize testing methods that are not generally done routinely like staged-Fault-tests.

However, many of the Protection System attributes which are verified during commission testing are not subject to age related or service related degradation, and need not be re-verified within an ongoing maintenance program. Example--it is not necessary to re-verify correct terminal strip wiring on an ongoing basis.

PRC-005-6 assumes that thorough commission testing was performed prior to a Protection System being placed in service. PRC-005-6 requires performance of maintenance activities that are deemed necessary to detect and correct plausible age and service related degradation of components, such that a properly built and commission tested Protection System will continue to function as designed over its service life.

It should be noted that commission testing frequently is performed by a different organization than that which is responsible for the ongoing maintenance of the Protection System. Furthermore, the commission testing activities will not necessarily correlate directly with the maintenance activities required by the standard. As such, it is very likely that commission testing records will deviate significantly from maintenance records in both form and content; and, therefore, it is not necessary to maintain commission testing records within the maintenance program documentation.

Notwithstanding the differences in records, an entity would be wise to retain commissioning records to show a maintenance start date. (See below). An entity that requires that their commissioning tests have, at a minimum, the requirements of PRC-005-6 would help that entity prove time interval maximums by setting the initial time clock.

How do you determine the initial due date for maintenance?

The initial due date for maintenance should be based upon when a Protection System was tested. Alternatively, an entity may choose to use the date of completion of the commission testing of the Protection System component and the system was placed into service as the starting point in determining its first maintenance due dates. Whichever method is chosen, for newly installed Protection Systems the components should not be placed into service until minimum maintenance activities have taken place.

It is conceivable that there can be a (substantial) difference in time between the date of testing, as compared to the date placed into service. The use of the "Calendar Year" language can help determine the next due date without too much concern about being non-compliant for missing test dates by a small amount (provided your dates are not already at the end of a year). However, if there is a substantial amount of time difference between testing and in-service dates, then the testing date should be followed because it is the degradation of components that is the concern. While accuracy fluctuations may decrease when components are not energized, there are cases when degradation can take place, even though the device is not energized. Minimizing the time between commissioning tests and in-service dates will help.

If I miss two battery inspections four times out of 100 Protection System components on my transmission system, does that count as 2% or 8% when counting Violation Severity Level (VSL) for R3?

The entity failed to complete its scheduled program on two of its 100 Protection System components, which would equate to 2% for application to the VSL Table for Requirement R3. This VSL is written to compare missed components to total components. In this case two components out of 100 were missed, or 2%.

How do I achieve a "grace period" without being out of compliance?

The objective here is to create a time extension within your own PSMP that still does not violate the maximum time intervals stated in the standard. Remember that the maximum time intervals listed in the Tables cannot be extended.

For the purposes of this example, concentrating on just unmonitored protective relays – Table 1-1 specifies a maximum time interval (between the mandated maintenance activities) of six calendar years. Your plan must ensure that your unmonitored relays are tested at least once every six calendar years. You could, within your PSMP, require that your unmonitored relays be tested every four calendar years, with a maximum allowable time extension of 18 calendar months. This allows an entity to have deadlines set for the auto-generation of work orders, but still has the flexibility in scheduling complex work schedules. This also allows for that 18 calendar months to act as a buffer, in effect a grace period within your PSMP, in the event of unforeseen events. You will note that this example of a maintenance plan interval has a planned time of four years; it also has a built-in time extension allowed within the PSMP, and yet does not exceed the maximum time interval allowed by the standard. So while there are no time extensions allowed beyond the standard, an entity can still have substantial flexibility to maintain their Protection System components.

8.3 Basis for Table 1 Intervals

When developing the original *Protection System Maintenance – A Technical Reference* in 2007, the SPCTF collected all available data from Regional Entities (REs) on time intervals recommended for maintenance and test programs. The recommendations vary widely in categorization of relays, defined maintenance actions, and time intervals, precluding development of intervals by averaging. The SPCTF also reviewed the 2005 Report [2] of the IEEE Power System Relaying Committee Working Group I-17 (Transmission Relay System Performance Comparison). Review of the I-17 report shows data from a small number of utilities, with no company identification or means of investigating the significance of particular results.

To develop a solid current base of practice, the SPCTF surveyed its members regarding their maintenance intervals for electromechanical and microprocessor relays, and asked the members to also provide definitively-known data for other entities. The survey represented 470 GW of peak Load, or 4% of the NERC peak Load. Maintenance interval averages were compiled by weighting reported intervals according to the size (based on peak Load) of the reporting utility. Thus, the averages more accurately represent practices for the large populations of Protection Systems used across the NERC regions.

The results of this survey with weighted averaging indicate maintenance intervals of five years for electromechanical or solid state relays, and seven years for unmonitored microprocessor relays.

A number of utilities have extended maintenance intervals for microprocessor relays beyond seven years, based on favorable experience with the particular products they have installed. To provide a technical basis for such extension, the SPCTF authors developed a recommendation of 10 years using the Markov modeling approach from [1], as summarized in Section 8.4. The results of this modeling depend on the completeness of self-testing or monitoring. Accordingly, this extended interval is allowed by Table 1, only when such relays are monitored as specified in the attributes of monitoring contained in Tables 1-1 through 1-5 and Table 2. Monitoring is capable of reporting Protection System health issues that are likely to affect performance within the 10 year time interval between verifications.

It is important to note that, according to modeling results, Protection System availability barely changes as the maintenance interval is varied below the 10-year mark. Thus, reducing the maintenance interval does not improve Protection System availability. With the assumptions of the model regarding how maintenance is carried out, reducing the maintenance interval actually degrades Protection System availability.

8.4 Basis for Extended Maintenance Intervals for Microprocessor Relays

Table 1 allows maximum verification intervals that are extended based on monitoring level. The industry has experience with self-monitoring microprocessor relays that leads to the Table 1 value for a monitored relay, as explained in Section 8.3. To develop a basis for the maximum interval for monitored relays in their *Protection System Maintenance – A Technical Reference*, the SPCTF used the methodology of Reference [1], which specifically addresses optimum routine maintenance intervals. The Markov modeling approach of [1] is judged to be valid for the design and typical failure modes of microprocessor relays.

The SPCTF authors ran test cases of the Markov model to calculate two key probability measures:

- Relay Unavailability - the probability that the relay is out of service due to failure or maintenance activity while the power system Element to be protected is in service.
- Abnormal Unavailability - the probability that the relay is out of service due to failure or maintenance activity when a Fault occurs, leading to failure to operate for the Fault.

The parameter in the Markov model that defines self-monitoring capability is ST (for self-test). ST = 0 if there is no self-monitoring; ST = 1 for full monitoring. Practical ST values are estimated to range from .75 to .95. The SPCTF simulation runs used constants in the Markov model that were the same as those used in [1] with the following exceptions:

Sn, Normal tripping operations per hour = 21600 (reciprocal of normal Fault clearing time of 10 cycles)

Sb, Backup tripping operations per hour = 4320 (reciprocal of backup Fault clearing time of 50 cycles)

Rc, Protected component repairs per hour = 0.125 (8 hours to restore the power system)

Rt, Relay routine tests per hour = 0.125 (8 hours to test a Protection System)

Rr, Relay repairs per hour = 0.08333 (12 hours to complete a Protection System repair after failure)

Experimental runs of the model showed low sensitivity of optimum maintenance interval to

these parameter adjustments.

The resulting curves for relay unavailability and abnormal unavailability versus maintenance interval showed a broad minimum (optimum maintenance interval) in the vicinity of 10 years – the curve is flat, with no significant change in either unavailability value over the range of 9, 10, or 11 years. This was true even for a relay mean time between Failures (MTBF) of 50 years, much lower than MTBF values typically published for these relays. Also, the Markov modeling indicates that both the relay unavailability and abnormal unavailability actually become higher with more frequent testing. This shows that the time spent on these more frequent tests yields no failure discoveries that approach the negative impact of removing the relays from service and running the tests.

The PSMT SDT discussed the practical need for “time-interval extensions” or “grace periods” to allow for scheduling problems that resulted from any number of business contingencies. The time interval discussions also focused on the need to reflect industry norms surrounding Generator outage frequencies. Finally, it was again noted that FERC Order 693 demanded maximum time intervals. “Maximum time intervals” by their very term negates any “time-interval extension” or “grace periods.” To recognize the need to follow industry norms on Generator outage frequencies and accommodate a form of time-interval extension, while still following FERC Order 693, the Standard Drafting Team arrived at a six-year interval for the electromechanical relay, instead of the five-year interval arrived at by the SPCTF. The PSMT SDT has followed the FERC directive for a *maximum* time interval and has determined that no extensions will be allowed. Six years has been set for the maximum time interval between manual maintenance activities. This maximum time interval also works well for maintenance cycles that have been in use in generator plants for decades.

For monitored relays, the PSMT SDT notes that the SPCTF called for 10 years as the interval between maintenance activities. This 10-year interval was chosen, even though there was “...no significant change in unavailability value over the range of 9, 10, or 11 years. This was true even for a relay Mean Time between Failures (MTBF) of 50 years...” The Standard Drafting Team again sought to align maintenance activities with known successful practices and outage schedules. The Standard does not allow extensions on any component of the Protection System; thus, the maximum allowed interval for these components has been set to 12 years. Twelve years also fits well into the traditional maintenance cycles of both substations and generator plants.

Also of note is the Table’s use of the term “Calendar” in the column for “Maximum Maintenance Interval.” The PSMT SDT deemed it necessary to include the term “Calendar” to facilitate annual maintenance planning, scheduling and implementation. This need is the result of known occurrences of system requirements that could cause maintenance schedules to be missed by a few days or weeks. The PSMT SDT chose the term “Calendar” to preclude the need to have schedules be met to the day. An electromechanical protective relay that is maintained in year number one need not be revisited until six years later (year number seven). For example, a relay was maintained April 10, 2008; maintenance would need to be completed no later than December 31, 2014.

Though not a requirement of this standard, to stay in line with many Compliance Enforcement Agencies audit processes an entity should define, within their own PSMP, the entity’s use of terms like annual, calendar year, etc. Then, once this is within the PSMP, the entity should abide by their chosen language.

9. Performance-Based Maintenance Process

In lieu of using the Table 1 intervals, a Performance-Based Maintenance process may be used to establish maintenance intervals (*PRC-005 Attachment A Criteria for a Performance-Based Protection System Maintenance Program*). A Performance-Based Maintenance process may justify longer maintenance intervals, or require shorter intervals relative to Table 1. In order to use a Performance-Based Maintenance process, the documented maintenance program must include records of repairs, adjustments, and corrections to covered Protection Systems in order to provide historical justification for intervals, other than those established in Table 1. Furthermore, the asset owner must regularly analyze these records of corrective actions to develop a ranking of causes. Recurrent problems are to be highlighted, and remedial action plans are to be documented to mitigate or eliminate recurrent problems.

Entities with Performance-Based Maintenance track performance of Protection Systems, demonstrate how they analyze findings of performance failures and aberrations, and implement continuous improvement actions. Since no maintenance program can ever guarantee that no malfunction can possibly occur, documentation of a Performance-Based Maintenance program would serve the utility well in explaining to regulators and the public a Misoperation leading to a major System outage event.

A Performance-Based Maintenance program requires auditing processes like those included in widely used industrial quality systems (such as *ISO 9001-2000, Quality Management Systems — Requirements*; or applicable parts of the NIST Baldrige National Quality Program). The audits periodically evaluate:

- The completeness of the documented maintenance process
- Organizational knowledge of and adherence to the process
- Performance metrics and documentation of results
- Remediation of issues
- Demonstration of continuous improvement.

In order to opt into a Performance-Based Maintenance (PBM) program, the asset owner must first sort the various Components into population segments. Any population segment must be comprised of at least 60 individual units; if any asset owner opts for PBM, but does not own 60 units to comprise a population, then that asset owner may combine data from other asset owners until the needed 60 units is aggregated. Each population segment must be composed of a grouping of Components of a consistent design standard or particular model or type from a single manufacturer and subjected to similar environmental factors. For example: One segment cannot be comprised of both GE & Westinghouse electro-mechanical lock-out relays; likewise, one segment cannot be comprised of 60 GE lock-out relays, 30 of which are in a dirty environment, and the remaining 30 from a clean environment. This PBM process cannot be applied to batteries,

but can be applied to all other Components, including (but not limited to) specific battery chargers, instrument transformers, trip coils and/or control circuitry (etc.).

9.1 Minimum Sample Size

Large Sample Size

An assumption that needs to be made when choosing a sample size is “the sampling distribution of the sample mean can be approximated by a normal probability distribution.” The Central Limit Theorem states: “In selecting simple random samples of size n from a population, the sampling distribution of the sample mean \bar{x} can be approximated by a normal probability distribution as the sample size becomes large.” (Essentials of Statistics for Business and Economics, Anderson, Sweeney, Williams, 2003.)

To use the Central Limit Theorem in statistics, the population size should be large. The references below are supplied to help define what is large.

“... whenever we are using a large simple random sample (rule of thumb: $n \geq 30$), the central limit theorem enables us to conclude that the sampling distribution of the sample mean can be approximated by a normal distribution.” (Essentials of Statistics for Business and Economics, Anderson, Sweeney, Williams, 2003.)

“If samples of size n , when $n \geq 30$, are drawn from any population with a mean μ and a standard deviation σ , the sampling distribution of sample means approximates a normal distribution. The greater the sample size, the better the approximation.” (Elementary Statistics - Picturing the World, Larson, Farber, 2003.)

“The sample size is large (generally $n \geq 30$)... (Introduction to Statistics and Data Analysis - Second Edition, Peck, Olson, Devore, 2005.)

“... the normal is often used as an approximation to the t distribution in a test of a null hypothesis about the mean of a normally distributed population when the population variance is estimated from a relatively large sample. A sample size exceeding 30 is often given as a minimal size in this connection.” (Statistical Analysis for Business Decisions, Peters, Summers, 1968.)

Error of Distribution Formula

Beyond the large sample size discussion above, a sample size requirement can be estimated using the bound on the Error of Distribution Formula when the expected result is of a “Pass/Fail” format and will be between 0 and 1.0.

The Error of Distribution Formula is:

$$B = z \sqrt{\frac{\pi(1-\pi)}{n}}$$

Where:

B = bound on the error of distribution (allowable error)

z = standard error

π = expected failure rate

n = sample size required

Solving for n provides:

$$n = \pi(1 - \pi) \left(\frac{z}{B} \right)^2$$

Minimum Population Size to use Performance-Based Program

One entity's population of components should be large enough to represent a sizeable sample of a vendor's overall population of manufactured devices. For this reason, the following assumptions are made:

B = 5%

z = 1.96 (This equates to a 95% confidence level)

π = 4%

Using the equation above, n=59.0.

Minimum Sample Size to evaluate Performance-Based Program

The number of components that should be included in a sample size for evaluation of the appropriate testing interval can be smaller because a lower confidence level is acceptable since the sample testing is repeated or updated annually. For this reason, the following assumptions are made:

B = 5%

z = 1.44 (85% confidence level)

π = 4%

Using the equation above, n=31.8.

Recommendation

Based on the above discussion, a sample size should be at least 30 to allow use of the equation mentioned. Using this and the results of the equation, the following numbers are recommended (and required within the standard):

Minimum Population Size to use Performance-Based Maintenance Program = 60

Minimum Sample Size to evaluate Performance-Based Program = 30.

Once the population segment is defined, then maintenance must begin within the intervals as outlined for the device described in the Tables 1-1 through 1-5. Time intervals can be lengthened provided the last year's worth of components tested (or the last 30 units maintained, whichever is more) had fewer than 4% Countable Events. It is notable that 4% is specifically chosen because an entity with a small population (30 units) would have to adjust its time intervals between maintenance if more than one Countable Event was found to have occurred during the last

analysis period. A smaller percentage would require that entity to adjust the time interval between maintenance activities if even one unit is found out of tolerance or causes a Misoperation.

The minimum number of units that can be tested in any given year is 5% of the population. Note that this 5% threshold sets a practical limitation on total length of time between intervals at 20 years.

If at any time the number of Countable Events equals or exceeds 4% of the last year's tested components (or the last 30 units maintained, whichever is more), then the time period between manual maintenance activities must be decreased. There is a time limit on reaching the decreased time at which the Countable Events is less than 4%; this must be attained within three years.

Performance-Based Program Evaluation Example

The 4% performance target was derived as a protection system performance target and was selected based on the drafting team's experience and studies performed by several utilities. This is not derived from the performance of discrete devices. Microprocessor relays and electromechanical relays have different performance levels. It is not appropriate to compare these performance levels to each other. The performance of the segment should be compared to the 4% performance criteria.

In consideration of the use of Performance Based Maintenance (PBM), the user should consider the effects of extended testing intervals and the established 4% failure rate. In the table shown below, the segment is 1000 units. As the testing interval (in years) increases, the number of units tested each year decreases. The number of countable events allowed is 4% of the tested units. Countable events are the failure of a Component requiring repair or replacement, any corrective actions performed during the maintenance test on the units within the testing segment (units per year), or any misoperation attributable to hardware failure or calibration failure found within the entire segment (1000 units) during the testing year.

Example: 1000 units in the segment with a testing interval of 8 years: The number of units tested each year will be 125 units. The total allowable countable events equals: $125 \times .04 = 5$. This number includes failure of a Component requiring repair or replacement, corrective issues found during testing, and the total number of misoperations (attributable to hardware or calibration failure within the testing year) associated with the entire segment of 1000 units.

Example: 1000 units in the segment with a testing interval of 16 years: The number of units tested each year will be 63 units. The total allowable countable events equals: $63 \times .04 = 2.5$.

As shown in the above examples, doubling the testing interval reduces the number of allowable events by half.

Total number of units in the segment	1000
Failure rate	4.00%

Testing Intervals (Years)	Units Per Year	Acceptable Number of Countable Events per year	Yearly Failure Rate Based on 1000 Units in Segment
1	1000.00	40.00	4.00%
2	500.00	20.00	2.00%
4	250.00	10.00	1.00%
6	166.67	6.67	0.67%
8	125.00	5.00	0.50%
10	100.00	4.00	0.40%
12	83.33	3.33	0.33%
14	71.43	2.86	0.29%
16	62.50	2.50	0.25%
18	55.56	2.22	0.22%
20	50.00	2.00	0.20%

Using the prior year’s data, determine the maximum allowable maintenance interval for each Segment such that the Segment experiences Countable Events on no more than 4% of the Components within the Segment, for the greater of either the last 30 Components maintained or all Components maintained in the previous year.

Segment – Components of a consistent design standard, or a particular model or type from a single manufacturer that typically share other common elements. Consistent performance is expected across the entire population of a Segment. A Segment must contain at least sixty (60) individual Components.

Countable Event – A failure of a Component requiring repair or replacement, any condition discovered during the maintenance activities in Tables 1-1 through 1-5, Table 3, Table 4-1 through Table 4-3, and Table 5, which requires corrective action or a Protection System Misoperation attributed to hardware failure or calibration failure. Misoperations due to product design errors, software errors, relay settings different from specified settings, Protection System Component, Automatic Reclosing, or Sudden Pressure Relaying configuration or application errors are not included in Countable Events.

9.2 Frequently Asked Questions:

I’m a small entity and cannot aggregate a population of Protection System components to establish a segment required for a Performance-Based Protection System Maintenance Program. How can I utilize that opportunity?

Multiple asset owning entities may aggregate their individually owned populations of individual Protection System components to create a segment that crosses ownership boundaries. All entities participating in a joint program should have a single documented joint management

process, with consistent Protection System Maintenance Programs (practices, maintenance intervals and criteria), for which the multiple owners are individually responsible with respect to the requirements of the Standard. The requirements established for Performance-Based Maintenance must be met for the overall aggregated program on an ongoing basis.

The aggregated population should reflect all factors that affect consistent performance across the population, including any relevant environmental factors such as geography, power-plant vs. substation, and weather conditions.

Can an owner go straight to a Performance-Based Maintenance program schedule, if they have previously gathered records?

Yes--an owner can go to a Performance-Based Maintenance program immediately. The owner will need to comply with the requirements of a Performance-Based Maintenance program as listed in the Standard. Gaps in the data collected will not be allowed; therefore, if an owner finds that a gap exists such that they cannot prove that they have collected the data as required for a Performance-Based Maintenance program then they will need to wait until they can prove compliance.

When establishing a Performance-Based Maintenance program, can I use test data from the device manufacturer, or industry survey results, as results to help establish a basis for my Performance-Based intervals?

No--you must use actual in-service test data for the components in the segment.

What types of Misoperations or events are not considered Countable Events in the Performance-Based Protection System Maintenance (PBM) Program?

Countable Events are intended to address conditions that are attributed to hardware failure or calibration failure; that is, conditions that reflect deteriorating performance of the component. These conditions include any condition where the device previously worked properly, then, due to changes within the device, malfunctioned or degraded to the point that re-calibration (to within the entity's tolerance) was required.

For this purpose of tracking hardware issues, human errors resulting in Protection System Misoperations during system installation or maintenance activities are not considered Countable Events. Examples of excluded human errors include relay setting errors, design errors, wiring errors, inadvertent tripping of devices during testing or installation, and misapplication of Protection System components. Examples of misapplication of Protection System components include wrong CT or PT tap position, protective relay function misapplication, and components not specified correctly for their installation. Obviously, if one is setting up relevant data about hardware failures then human failures should be eliminated from the hardware performance analysis.

One example of human-error is not pertinent data might be in the area of testing "86" lock-out relays (LOR). "Entity A" has two types of LOR's type "X" and type "Y"; they want to move into a performance based maintenance interval. They have 1000 of each type, so the population variables are met. During electrical trip testing of all of their various schemes over the initial six-year interval they find zero type "X" failures, but human error led to tripping a BES Element 100 times; they find 100 type "Y" failures and had an additional 100 human-error caused tripping incidents. In this example the human-error caused Misoperations should not be used to judge the performance of either type of LOR. Analysis of the data might lead "Entity A" to change time intervals. Type "X" LOR can be placed into extended time interval testing because of its low failure

rate (zero failures) while Type “Y” would have to be tested more often than every 6 calendar years (100 failures divided by 1000 units exceeds the 4% tolerance level).

Certain types of Protection System component errors that cause Misoperations are not considered Countable Events. Examples of excluded component errors include device malfunctions that are correctable by firmware upgrades and design errors that do not impact protection function.

What are some examples of methods of correcting segment performance for Performance-Based Maintenance?

There are a number of methods that may be useful for correcting segment performance for mal-performing segments in a Performance-Based Maintenance system. Some examples are listed below.

- The maximum allowable interval, as established by the Performance-Based Maintenance system, can be decreased. This may, however, be slow to correct the performance of the segment.
- Identifiable sub-groups of components within the established segment, which have been identified to be the mal-performing portion of the segment, can be broken out as an independent segment for target action. Each resulting segment must satisfy the minimum population requirements for a Performance-Based Maintenance program in order to remain within the program.
- Targeted corrective actions can be taken to correct frequently occurring problems. An example would be replacement of capacitors within electromechanical distance relays if bad capacitors were determined to be the cause of the mal-performance.
- Components within the mal-performing segment can be replaced with other components (electromechanical distance relays with microprocessor relays, for example) to remove the mal-performing segment.

If I find (and correct) a Unresolved Maintenance Issue as a result of a Misoperation investigation (Re: PRC-004), how does this affect my Performance-Based Maintenance program?

If you perform maintenance on a Protection System component for any reason (including as part of a PRC-004 required Misoperation investigation/corrective action), the actions performed can count as a maintenance activity provided the activities in the relevant Tables have been done, and, if you desire, “reset the clock” on everything you’ve done. In a Performance-Based Maintenance program, you also need to record the Unresolved Maintenance Issue as a Countable Event within the relevant component group segment and use it in the analysis to determine your correct Performance-Based Maintenance interval for that component group. Note that “resetting the clock” should not be construed as interfering with an entity’s routine testing schedule because the “clock-reset” would actually make for a decreased time interval by the time the next routine test schedule comes around.

For example, a relay scheme, consisting of four relays, is tested on 1-1-11 and the PSMP has a time interval of 3 calendar years with an allowable extension of 1 calendar year. The relay would be due again for routine testing before the end of the year 2015. This hypothetical relay scheme has a Misoperation on 6-1-12 that points to one of the four relays as bad. Investigation proves a

bad relay and a new one is tested and installed in place of the original. This replacement relay actually could be retested before the end of the year 2016 (clock-reset) and not be out of compliance. This requires tracking maintenance by individual relays and is allowed. However, many companies schedule maintenance in other ways like by substation or by circuit breaker or by relay scheme. By these methods of tracking maintenance that “replaced relay” will be retested before the end of the year 2015. This is also acceptable. In no case was a particular relay tested beyond the PSMP of four years max, nor was the 6 year max of the Standard exceeded. The entity can reset the clock if they desire or the entity can continue with original schedules and, in effect, test even more frequently.

Why are batteries excluded from PBM? What about exclusion of batteries from condition based maintenance?

Batteries are the only element of a Protection System that is a perishable item with a shelf life. As a perishable item batteries require not only a constant float charge to maintain their freshness (charge), but periodic inspection to determine if there are problems associated with their aging process and testing to see if they are maintaining a charge or can still deliver their rated output as required.

Besides being perishable, a second unique feature of a battery that is unlike any other Protection System element, is that a battery uses chemicals, metal alloys, plastics, welds, and bonds that must interact with each other to produce the constant dc source required for Protection Systems, undisturbed by ac system Disturbances.

No type of battery manufactured today for Protection System application is free from problems of the sort that can only be detected over time by inspection and test. These problems can arise from variances in the manufacturing process, chemicals and alloys used in the construction of the individual cells, quality of welds and bonds to connect the components, the plastics used to make batteries, and the cell forming process for the individual battery cells.

Other problems that require periodic inspection and testing can result from transportation from the factory to the job site, length of time before a charge is put on the battery, the method of installation, the voltage level and duration of equalize charges, the float voltage level used, and the environment that the battery is installed in.

All of the above mentioned factors, as well as several more not discussed here, are beyond the control of the Functional Entities that want to use a Performance-Based Protection System Maintenance (PBM) program. Inherent variances in the aging process of a battery cell make establishment of a designated segment based on manufacturer and type of battery impossible.

The whole point of PBM is that if all variables are isolated then common aging and performance criteria would be the same. However, there are too many variables in the electrochemical process to completely isolate all of the performance-changing criteria.

Similarly, Functional Entities that want to establish a condition-based maintenance program using the highest levels of monitoring, resulting in the least amount of hands-on maintenance activity, cannot completely eliminate some periodic maintenance of the battery used in a station dc supply. Inspection of the battery is required on a Maximum Maintenance Interval listed in the tables due to the aging processes of station batteries. However, higher degrees of monitoring of a battery can eliminate the requirement for some periodic testing and some inspections (see Table 1-4).

Please provide an example of the calculations involved in extending maintenance time intervals using PBM.

Entity has 1000 GE-HEA lock-out relays; this is greater than the minimum sample requirement of 60. They start out testing all of the relays within the prescribed Table requirements (6 year max) by testing the relays every 5 years. The entity's plan is to test 200 units per year; this is greater than the minimum sample size requirement of 30. For the sake of example only the following will show 6 failures per year, reality may well have different numbers of failures every year. PBM requires annual assessment of failures found per units tested. After the first year of tests the entity finds 6 failures in the 200 units tested. $6/200 = 3\%$ failure rate. This entity is now allowed to extend the maintenance interval if they choose. The entity chooses to extend the maintenance interval of this population segment out to 10 years. This represents a rate of 100 units tested per year; entity selects 100 units to be tested in the following year. After that year of testing these 100 units the entity again finds 6 failed units. $6/100 = 6\%$ failures. This entity has now exceeded the acceptable failure rate for these devices and must accelerate testing of all of the units at a higher rate such that the failure rate is found to be less than 4% per year; the entity has three years to get this failure rate down to 4% or less (per year). In response to the 6% failure rate, the entity decreases the testing interval to 8 years. This means that they will now test 125 units per year ($1000/8$). The entity has just two years left to get the test rate corrected.

After a year, they again find six failures out of the 125 units tested. $6/125 = 5\%$ failures. In response to the 5% failure rate, the entity decreases the testing interval to seven years. This means that they will now test 143 units per year ($1000/7$). The entity has just one year left to get the test rate corrected. After a year, they again find six failures out of the 143 units tested. $6/143 = 4.2\%$ failures.

(Note that the entity has tried five years and they were under the 4% limit and they tried seven years and they were over the 4% limit. They must be back at 4% failures or less in the next year so they might simply elect to go back to five years.)

Instead, in response to the 5% failure rate, the entity decreases the testing interval to six years. This means that they will now test 167 units per year ($1000/6$). After a year, they again find six failures out of the 167 units tested. $6/167 = 3.6\%$ failures. Entity found that they could maintain the failure rate at no more than 4% failures by maintaining the testing interval at six years or less. Entity chose six-year interval and effectively extended their TBM (five years) program by 20%.

A note of practicality is that an entity will probably be in better shape to lengthen the intervals between tests if the failure rate is less than 2%. But the requirements allow for annual adjustments, if the entity desires. As a matter of maintenance management, an ever-changing test rate (units tested/year) may be un-workable.

Note that the "5% of components" requirement effectively sets a practical limit of 20 year maximum PBM interval. Also of note is the "3 years" requirement; an entity might arbitrarily extend time intervals from six years to 20 years. In the event that an entity finds a failure rate greater than 4%, then the test rate must be accelerated such that within three years the failure rate must be brought back down to 4% or less.

Here is a table that demonstrates the values discussed:

Year #	Total Population (P)	Test Interval (I)	Units to be Tested (U= P/I)	# of Failures Found (F)	Failure Rate (=F/U)	Decision to Change Interval Yes or No	Interval Chosen
1	1000	5 yrs	200	6	3%	Yes	10 yrs
2	1000	10 yrs	100	6	6%	Yes	8 yrs
3	1000	8 yrs	125	6	5%	Yes	7 yrs
4	1000	7 yrs	143	6	4.2%	Yes	6 yrs
5	1000	6 yrs	167	6	3.6%	No	6 yrs

Please provide an example of the calculations involved in extending maintenance time intervals using PBM for control circuitry.

Note that the following example captures “Control Circuitry” as all of the trip paths associated with a particular trip coil of a circuit breaker. An entity is not restricted to this method of counting control circuits. Perhaps another method an entity would prefer would be to simply track every individual (parallel) trip path. Or perhaps another method would be to track all of the trip outputs from a specific (set) of relays protecting a specific element.

The designation of what constitutes a control circuit component is very dependent upon how an entity performs and tracks the testing of the control circuitry. Some entities test their control circuits on a breaker basis whereas others test their circuitry on a local zone of protection basis. Thus, entities are allowed the latitude to designate their own definitions of control circuit components. Another example of where the entity has some discretion on determining what constitutes a single component is the voltage and current sensing devices, where the entity may choose either to designate a full three-phase set of such devices or a single device as a single component.

In Attachment A (PBM) the definition of Segment is:

Segment –*Components of a consistent design standard, or a particular model or type from a single manufacturer that typically share other common elements. Consistent performance is expected across the entire population of a segment. A segment must contain at least sixty (60) individual components.*

Example:

Entity has 1,000 circuit breakers, all of which have two trip coils, for a total of 2,000 trip coils; if all circuitry was designed and built with a consistent (internal entity) standard, then this is greater than the minimum sample requirement of 60.

For the sake of further example, the following facts are given:

Half of all relay panels (500) were built 40 years ago by an outside contractor, consisted of asbestos wrapped 600V-insulation panel wiring, and the cables exiting the control house are THHN pulled in conduit direct to exactly half of all of the various circuit breakers. All of the relay panels and cable pulls were built with consistent standards and consistent performance standard

expectations within the segment (which is greater than 60). Each relay panel has redundant microprocessor (MPC) relays (retrofitted); each MPC relay supplies an individual trip output to each of the two trip coils of the assigned circuit breaker.

Approximately 35 years ago, the entity developed their own internal construction crew and now builds all of their own relay panels from parts supplied from vendors that meet the entity's specifications, including SIS 600V insulation wiring and copper-sheathed cabling within the direct conduits to circuit breakers. The construction crew uses consistent standards in the construction. This newer segment of their control circuitry population is different than the original segment, consistent (standards, construction and performance expectations) within the new segment and constitutes the remainder of the entity's population (another 500 panels and the cabling to the remaining 500 circuit breakers). Each relay panel has redundant microprocessor (MPC) relays; each MPC relay supplies an individual trip output to each of the two trip coils of the assigned circuit breaker. Every trip path in this newer segment has a device that monitors the voltage directly across the trip contacts of the MPC relays and alarms via RTU and SCADA to the operations control room. This monitoring device, when not in alarm, demonstrates continuity all the way through the trip coil, cabling and wiring back to the trip contacts of the MPC relay.

The entity is tracking 2,000 trip coils (each consisting of multiple trip paths) in each of these two segments. But half of all of the trip paths are monitored; therefore, the trip paths are continuously tested and the circuit will alarm when there is a failure. These alarms have to be verified every 12 years for correct operation.

The entity now has 1,000 trip coils (and associated trip paths) remaining that they have elected to count as control circuits. The entity has instituted a process that requires the verification of every trip path to each trip coil (one unit), including the electrical activation of the trip coil. (The entity notes that the trip coils will have to be tripped electrically more often than the trip path verification, and is taking care of this activity through other documentation of Real-time Fault operations.)

They start out testing all of the trip coil circuits within the prescribed Table requirements (12-year max) by testing the trip circuits every 10 years. The entity's plan is to test 100 units per year; this is greater than the minimum sample size requirement of 30. For the sake of example only, the following will show three failures per year; reality may well have different numbers of failures every year. PBM requires annual assessment of failures found per units tested. After the first year of tests, the entity finds three failures in the 100 units tested. $3/100 = 3\%$ failure rate.

This entity is now allowed to extend the maintenance interval, if they choose. The entity chooses to extend the maintenance interval of this population segment out to 20 years. This represents a rate of 50 units tested per year; entity selects 50 units to be tested in the following year. After that year of testing these 50 units, the entity again finds three failed units. $3/50 = 6\%$ failures.

This entity has now exceeded the acceptable failure rate for these devices and must accelerate testing of all of the units at a higher rate, such that the failure rate is found to be less than 4% per year; the entity has three years to get this failure rate down to 4% or less (per year).

In response to the 6% failure rate, the entity decreases the testing interval to 16 years. This means that they will now test 63 units per year ($1000/16$). The entity has just two years left to get the

test rate corrected. After a year, they again find three failures out of the 63 units tested. $3/63 = 4.76\%$ failures.

In response to the $>4\%$ failure rate, the entity decreases the testing interval to 14 years. This means that they will now test 72 units per year ($1000/14$). The entity has just one year left to get the test rate corrected. After a year, they again find three failures out of the 72 units tested. $3/72 = 4.2\%$ failures.

(Note that the entity has tried 10 years, and they were under the 4% limit; and they tried 14 years, and they were over the 4% limit. They must be back at 4% failures or less in the next year, so they might simply elect to go back to 10 years.)

Instead, in response to the 4.2% failure rate, the entity decreases the testing interval to 12 years. This means that they will now test 84 units per year ($1000/12$). After a year, they again find three failures out of the 84 units tested. $3/84 = 3.6\%$ failures.

Entity found that they could maintain the failure rate at no more than 4% failures by maintaining the testing interval at 12 years or less. Entity chose 12-year interval, and effectively extended their TBM (10 years) program by 20%.

A note of practicality is that an entity will probably be in better shape to lengthen the intervals between tests if the failure rate is less than 2%. But the requirements allow for annual adjustments if the entity desires. As a matter of maintenance management, an ever-changing test rate (units tested / year) may be un-workable.

Note that the “5% of components” requirement effectively sets a practical limit of 20-year maximum PBM interval. Also of note is the “3 years” requirement; an entity might arbitrarily extend time intervals from six years to 20 years. In the event that an entity finds a failure rate greater than 4%, then the test rate must be accelerated such that within three years the failure rate must be brought back down to 4% or less.

Here is a table that demonstrates the values discussed:

Year #	Total Population (P)	Test Interval (I)	Units to be Tested (U= P/I)	# of Failures Found (F)	Failure Rate (=F/U)	Decision to Change Interval Yes or No	Interval Chosen
1	1000	10 yrs	100	3	3%	Yes	20 yrs
2	1000	20 yrs	50	3	6%	Yes	16yrs
3	1000	16 yrs	63	3	4.8%	Yes	14 yrs
4	1000	14 yrs	72	3	4.2%	Yes	12 yrs
5	1000	12 yrs	84	3	3.6%	No	12 yrs

Please provide an example of the calculations involved in extending maintenance time intervals using PBM for voltage and current sensing devices.

Note that the following example captures “voltage and current inputs to the protective relays” as all of the various current transformer and potential transformer signals associated with a particular set of relays used for protection of a specific Element. This entity calls this set of protective relays a “Relay Scheme.” Thus, this entity chooses to count PT and CT signals as a group instead of individually tracking maintenance activities to specific bushing CT’s or specific PT’s. An entity is not restricted to this method of counting voltage and current devices, signals and paths. Perhaps another method an entity would prefer would be to simply track every individual PT and CT. Note that a generation maintenance group may well select the latter because they may elect to perform routine off-line tests during generator outages, whereas a transmission maintenance group might create a process that utilizes Real-time system values measured at the relays.

The designation of what constitutes a control circuit component is very dependent upon how an entity performs and tracks the testing of the control circuitry. Some entities test their control circuits on a breaker basis whereas others test their circuitry on a local zone of protection basis. Thus, entities are allowed the latitude to designate their own definitions of control circuit components. Another example of where the entity has some discretion on determining what constitutes a single component is the voltage and current sensing devices, where the entity may choose either to designate a full three-phase set of such devices or a single device as a single component.

And in Attachment A (PBM) the definition of Segment:

Segment –*Components of a consistent design standard, or a particular model or type from a single manufacturer that typically share other common elements. Consistent performance is expected across the entire population of a segment. A segment must contain at least sixty (60) individual components.*

Example:

Entity has 2000 “Relay Schemes,” all of which have three current signals supplied from bushing CTs, and three voltage signals supplied from substation bus PT’s. All cabling and circuitry was designed and built with a consistent (internal entity) standard, and this population is greater than the minimum sample requirement of 60.

For the sake of further example the following facts are given:

Half of all relay schemes (1,000) are supplied with current signals from ANSI STD C800 bushing CTs and voltage signals from PTs built by ACME Electric MFR CO. All of the relay panels and cable pulls were built with consistent standards, and consistent performance standard expectations exist for the consistent wiring, cabling and instrument transformers within the segment (which is greater than 60).

The other half of the entity’s relay schemes have MPC relays with additional monitoring built-in that compare DNP values of voltages and currents (or Watts and VARs), as interpreted by the MPC relays and alarm for an entity-accepted tolerance level of accuracy. This newer segment of their “Voltage and Current Sensing” population is different than the original segment, consistent

(standards, construction and performance expectations) within the new segment and constitutes the remainder of the entity's population.

The entity is tracking many thousands of voltage and current signals within 2,000 relay schemes (each consisting of multiple voltage and current signals) in each of these two segments. But half of all of the relay schemes voltage and current signals are monitored; therefore, the voltage and current signals are continuously tested and the circuit will alarm when there is a failure; these alarms have to be verified every 12 years for correct operation.

The entity now has 1,000 relay schemes worth of voltage and current signals remaining that they have elected to count within their relay schemes designation. The entity has instituted a process that requires the verification of these voltage and current signals within each relay scheme (one unit).

(Please note - a problem discovered with a current or voltage signal found at the relay could be caused by anything from the relay, all the way to the signal source itself. Having many sources of problems can easily increase failure rates beyond the rate of failures of just one item (for example just PTs). It is the intent of the SDT to minimize failure rates of all of the equipment to an acceptable level; thus, any failure of any item that gets the signal from source to relay is counted. It is for this reason that the SDT chose to set the boundary at the ability of the signal to be delivered all the way to the relay.

The entity will start out measuring all of the relay scheme voltage and currents at the individual relays within the prescribed Table requirements (12 year max) by measuring the voltage and current values every 10 years. The entity's plan is to test 100 units per year; this is greater than the minimum sample size requirement of 30. For the sake of example only, the following will show three failures per year; reality may well have different numbers of failures every year. PBM requires annual assessment of failures found per units tested. After the first year of tests, the entity finds three failures in the 100 units tested. $3/100 = 3\%$ failure rate.

This entity is now allowed to extend the maintenance interval, if they choose. The entity chooses to extend the maintenance interval of this population segment out to 20 years. This represents a rate of 50 units tested per year; entity selects 50 units to be tested in the following year. After that year of testing these 50 units, the entity again finds three failed units. $3/50 = 6\%$ failures.

This entity has now exceeded the acceptable failure rate for these devices and must accelerate testing of all of the units at a higher rate, such that the failure rate is found to be less than 4% per year; the entity has three years to get this failure rate down to 4% or less (per year).

In response to the 6% failure rate, the entity decreases the testing interval to 16 years. This means that they will now test 63 units per year ($1000/16$). The entity has just two years left to get the test rate corrected. After a year, they again find three failures out of the 63 units tested. $3/63 = 4.76\%$ failures.

In response to the >4% failure rate, the entity decreases the testing interval to 14 years. This means that they will now test 72 units per year ($1000/14$). The entity has just one year left to get the test rate corrected. After a year, they again find three failures out of the 72 units tested. $3/72 = 4.2\%$ failures.

(Note that the entity has tried 10 years, and they were under the 4% limit; and they tried 14 years, and they were over the 4% limit. They must be back at 4% failures or less in the next year, so they might simply elect to go back to 10 years.)

Instead, in response to the 4.2% failure rate, the entity decreases the testing interval to 12 years. This means that they will now test 84 units per year (1,000/12). After a year, they again find three failures out of the 84 units tested. $3/84 = 3.6\%$ failures.

Entity found that they could maintain the failure rate at no more than 4% failures by maintaining the testing interval at 12 years or less. Entity chose 12-year interval and effectively extended their TBM (10 years) program by 20%.

A note of practicality is that an entity will probably be in better shape to lengthen the intervals between tests if the failure rate is less than 2%. But the requirements allow for annual adjustments, if the entity desires. As a matter of maintenance management, an ever-changing test rate (units tested/year) may be un-workable.

Note that the “5% of components” requirement effectively sets a practical limit of 20-year maximum PBM interval. Also of note is the “3 years” requirement; an entity might arbitrarily extend time intervals from six years to 20 years. In the event that an entity finds a failure rate greater than 4%, then the test rate must be accelerated such that within three years the failure rate must be brought back down to 4% or less.

Here is a table that demonstrates the values discussed:

Year #	Total Population (P)	Test Interval (I)	Units to be Tested (U= P/I)	# of Failures Found (F)	Failure Rate (=F/U)	Decision to Change Interval Yes or No	Interval Chose
1	1000	10 yrs	100	3	3%	Yes	20 yrs
2	1000	20 yrs	50	3	6%	Yes	16yrs
3	1000	16 yrs	63	3	4.8%	Yes	14 yrs
4	1000	14 yrs	72	3	4.2%	Yes	12 yrs
5	1000	12 yrs	84	3	3.6%	No	12 yrs

10. Overlapping the Verification of Sections of the Protection System

Tables 1-1 through 1-5 require that every Protection System component be periodically verified. One approach, but not the only method, is to test the entire protection scheme as a unit, from the secondary windings of voltage and current sources to breaker tripping. For practical ongoing verification, sections of the Protection System may be tested or monitored individually. The boundaries of the verified sections must overlap to ensure that there are no gaps in the verification. See Appendix A of this Supplementary Reference for additional discussion on this topic.

All of the methodologies expressed within this report may be combined by an entity, as appropriate, to establish and operate a maintenance program. For example, a Protection System may be divided into multiple overlapping sections with a different maintenance methodology for each section:

- Time-based maintenance with appropriate maximum verification intervals for categories of equipment, as given in the Tables 1-1 through 1-5;
- Monitoring as described in Tables 1-1 through 1-5;
- A Performance-Based Maintenance program as described in Section 9 above, or Attachment A of the standard;
- Opportunistic verification using analysis of Fault records, as described in Section 11

10.1 Frequently Asked Questions:

My system has alarms that are gathered once daily through an auto-polling system; this is not really a conventional SCADA system but does it meet the Table 1 requirements for inclusion as a monitored system?

Yes--provided the auto-polling that gathers the alarms reports those alarms to a location where the action can be initiated to correct the Unresolved Maintenance Issue. This location does not have to be the location of the engineer or the technician that will eventually repair the problem, but rather a location where the action can be initiated.

11. Monitoring by Analysis of Fault Records

Many users of microprocessor relays retrieve Fault event records and oscillographic records by data communications after a Fault. They analyze the data closely if there has been an apparent Misoperation, as NERC standards require. Some advanced users have commissioned automatic Fault record processing systems that gather and archive the data. They search for evidence of component failures or setting problems hidden behind an operation whose overall outcome seems to be correct. The relay data may be augmented with independently captured Digital Fault Recorder (DFR) data retrieved for the same event.

Fault data analysis comprises a legitimate CBM program that is capable of reducing the need for a manual time-interval based check on Protection Systems whose operations are analyzed. Even electromechanical Protection Systems instrumented with DFR channels may achieve some CBM benefit. The completeness of the verification then depends on the number and variety of Faults in the vicinity of the relay that produce relay response records and the specific data captured.

A typical Fault record will verify particular parts of certain Protection Systems in the vicinity of the Fault. For a given Protection System installation, it may or may not be possible to gather within a reasonable amount of time an ensemble of internal and external Fault records that completely verify the Protection System.

For example, Fault records may verify that the particular relays that tripped are able to trip via the control circuit path that was specifically used to clear that Fault. A relay or DFR record may indicate correct operation of the protection communications channel. Furthermore, other nearby Protection Systems may verify that they restrain from tripping for a Fault just outside their respective zones of protection. The ensemble of internal Fault and nearby external Fault event data can verify major portions of the Protection System, and reset the time clock for the Table 1 testing intervals for the verified components only.

What can be shown from the records of one operation is very specific and limited. In a panel with multiple relays, only the specific relay(s) whose operation can be observed without ambiguity should be used. Be careful about using Fault response data to verify that settings or calibration are correct. Unless records have been captured for multiple Faults close to either side of a setting boundary, setting or calibration could still be incorrect.

PMU data, much like DME data, can be utilized to prove various components of the Protection System. Obviously, care must be taken to attribute proof only to the parts of a Protection System that can actually be proven using the PMU or DME data.

If Fault record data is used to show that portions or all of a Protection System have been verified to meet Table 1 requirements, the owner must retain the Fault records used, and the maintenance-related conclusions drawn from this data and used to defer Table 1 tests, for at least the retention time interval given in Section 8.2.

11.1 Frequently Asked Questions:

I use my protective relays for Fault and Disturbance recording, collecting oscillographic records and event records via communications for Fault analysis to meet NERC and DME requirements. What are the maintenance requirements for the relays?

For relays used only as Disturbance Monitoring Equipment, NERC Standard PRC-018-1 R3 & R6 states the maintenance requirements and is being addressed by a standards activity that is revising PRC-002-1 and PRC-018-1. For protective relays “that are designed to provide protection for the BES,” this standard applies, even if they also perform DME functions.

12. Importance of Relay Settings in Maintenance Programs

In manual testing programs, many utilities depend on pickup value or zone boundary tests to show that the relays have correct settings and calibration. Microprocessor relays, by contrast, provide the means for continuously monitoring measurement accuracy. Furthermore, the relay digitizes inputs from one set of signals to perform all measurement functions in a single self-monitoring microprocessor system. These relays do not require testing or calibration of each setting.

However, incorrect settings may be a bigger risk with microprocessor relays than with older relays. Some microprocessor relays have hundreds or thousands of settings, many of which are critical to Protection System performance.

Monitoring does not check measuring element settings. Analysis of Fault records may or may not reveal setting problems. To minimize risk of setting errors after commissioning, the user should enforce strict settings data base management, with reconfirmation (manual or automatic) that the installed settings are correct whenever maintenance activity might have changed them; for background and guidance, see [5] in References.

Table 1 requires that settings must be verified to be as specified. The reason for this requirement is simple: With legacy relays (non-microprocessor protective relays), it is necessary to know the value of the intended setting in order to test, adjust and calibrate the relay. Proving that the relay works per specified setting was the de facto procedure. However, with the advanced microprocessor relays, it is possible to change relay settings for the purpose of verifying specific functions and then neglect to return the settings to the specified values. While there is no specific requirement to maintain a settings management process, there remains a need to verify that the settings left in the relay are the intended, specified settings. This need may manifest itself after any of the following:

- One or more settings are changed for any reason.
- A relay fails and is repaired or replaced with another unit.
- A relay is upgraded with a new firmware version.

12.1 Frequently Asked Questions:

How do I approach testing when I have to upgrade firmware of a microprocessor relay?

The entity should ensure that the relay continues to function properly after implementation of firmware changes. Some entities may have a Research and Development (R&D) department that might routinely run acceptance tests on devices with firmware upgrades before allowing the upgrade to be installed. Other entities may rely upon the vigorous testing of the firmware OEM. An entity has the latitude to install devices and/or programming that they believe will perform to their satisfaction. If an entity should choose to perform the maintenance activities specified in the Tables following a firmware upgrade, then they may, if they choose, reset the time clock on that set of maintenance activities so that they would not have to repeat the maintenance on

its regularly scheduled cycle. (However, for simplicity in maintenance schedules, some entities may choose to not reset this time clock; it is merely a suggested option.)

If I upgrade my old relays, then do I have to maintain my previous equipment maintenance documentation?

If an equipment item is repaired or replaced, then the entity can restart the maintenance-activity-time-interval-clock, if desired; however, the replacement of equipment does not remove any documentation requirements. The requirements in the standard are intended to ensure that an entity has a maintenance plan, and that the entity adheres to minimum activities and maximum time intervals. The documentation requirements are intended to help an entity demonstrate compliance. For example, saving the dates and records of the last two maintenance activities is intended to demonstrate compliance with the interval. Therefore, if you upgrade or replace equipment, then you still must maintain the documentation for the previous equipment, thus demonstrating compliance with the time interval requirement prior to the replacement action.

We have a number of installations where we have changed our Protection System components. Some of the changes were upgrades, but others were simply system rating changes that merely required taking relays "out-of-service". What are our responsibilities when it comes to "out-of-service" devices?

Assuming that your system up-rates, upgrades and overall changes meet any and all other requirements and standards, then the requirements of PRC-005-6 are simple – if the Protection System component performs a Protection System function, then it must be maintained. If the component no longer performs Protection System functions, then it does not require maintenance activities under the Tables of PRC-005-6. While many entities might physically remove a component that is no longer needed, there is no requirement in PRC-005-6 to remove such component(s). Obviously, prudence would dictate that an “out-of-service” device is truly made inactive. There are no record requirements listed in PRC-005-6 for Protection System components not used.

While performing relay testing of a protective device on our Bulk Electric System, it was discovered that the protective device being tested was either broken or out of calibration. Does this satisfy the relay testing requirement, even though the protective device tested bad, and may be unable to be placed back into service?

Yes, PRC-005-6 requires entities to perform relay testing on protective devices on a given maintenance cycle interval. By performing this testing, the entity has satisfied PRC-005-6 requirement, although the protective device may be unable to be returned to service under normal calibration adjustments. Requirement R5 states:

“R5. Each Transmission Owner, Generator Owner, and Distribution Provider shall demonstrate efforts to correct any identified Unresolved Maintenance Issues.”

Also, when a failure occurs in a Protection System, power system security may be comprised, and notification of the failure must be conducted in accordance with relevant NERC standards.

If I show the protective device out of service while it is being repaired, then can I add it back as a new protective device when it returns? If not, my relay testing history would show that I was out of compliance for the last maintenance cycle.

The maintenance and testing requirements (Requirement R5) state “...shall demonstrate efforts to correct any identified Unresolved Maintenance Issues...” The type of corrective activity is not stated; however, it could include repairs or replacements.

Your documentation requirements will increase, of course, to demonstrate that your device tested bad and had corrective actions initiated. Your regional entity might ask about the status of your corrective actions.

13. Self-Monitoring Capabilities and Limitations

Microprocessor relay proponents have cited the self-monitoring capabilities of these products for nearly 20 years. Theoretically, any element that is monitored does not need a periodic manual test. A problem today is that the community of manufacturers and users has not created clear documentation of exactly what is and is not monitored. Some unmonitored but critical elements are buried in installed systems that are described as self-monitoring.

To utilize the extended time intervals allowed by monitoring, the user must document that the monitoring attributes of the device match the minimum requirements listed in the Table 1.

Until users are able to document how all parts of a system which are required for the protective functions are monitored or verified (with help from manufacturers), they must continue with the unmonitored intervals established in Tables 1, 3, 4 and 5 and any associated sub-tables.

Going forward, manufacturers and users can develop mappings of the monitoring within relays, and monitoring coverage by the relay of user circuits connected to the relay terminals.

To enable the use of the most extensive monitoring (and never again have a hands-on maintenance requirement), the manufacturers of the microprocessor-based self-monitoring components in the Protection System should publish for the user a document or map that shows:

- How all internal elements of the product are monitored for any failure that could impact Protection System performance.
- Which connected circuits are monitored by checks implemented within the product; how to connect and set the product to assure monitoring of these connected circuits; and what circuits or potential problems are not monitored.

This manufacturer's information can be used by the registered entity to document compliance of the monitoring attributes requirements by:

- Presenting or referencing the product manufacturer's documents.
- Explaining in a system design document the mapping of how every component and circuit that is critical to protection is monitored by the microprocessor product(s) or by other design features.
- Extending the monitoring to include the alarm transmission Facilities through which failures are reported within a given time frame to allocate where action can be taken to initiate resolution of the alarm attributed to an Unresolved Maintenance Issue, so that failures of monitoring or alarming systems also lead to alarms and action.
- Documenting the plans for verification of any unmonitored components according to the requirements of Tables 1, 3, 4 and 5 and any associated sub-tables.

13.1 Frequently Asked Questions:

I can't figure out how to demonstrate compliance with the requirements for the highest level of monitoring of Protection Systems. Why does this Maintenance Standard describe a maintenance program approach I cannot achieve?

Demonstrating compliance with the requirements for the highest level of monitoring any particular component of Protection Systems is likely to be very involved, and may include detailed manufacturer documentation of complete internal monitoring within a device, comprehensive design drawing reviews, and other detailed documentation. This standard does not presume to specify what documentation must be developed; only that it must be documented.

There may actually be some equipment available that is capable of meeting these highest levels of monitoring criteria, in which case it may be maintained according to the highest level of monitoring shown on the Tables. However, even if there is no equipment available today that can meet this level of monitoring, the standard establishes the necessary requirements for when such equipment becomes available.

By creating a roadmap for development, this provision makes the standard technology-neutral. The Standard Drafting Team wants to avoid the need to revise the standard in a few years to accommodate technology advances that may be coming to the industry.

14. Notification of Protection System or Automatic Reclosing Failures

When a failure occurs in a Protection System or Automatic Reclosing, power system security may be compromised, and notification of the failure must be conducted in accordance with relevant NERC standard(s). Knowledge of the failure may impact the system operator's decisions on acceptable Loading conditions.

This formal reporting of the failure and repair status to the system operator by the Protection System or Automatic Reclosing owner also encourages the system owner to execute repairs as rapidly as possible. In some cases, a microprocessor relay or carrier set can be replaced in hours; wiring termination failures may be repaired in a similar time frame. On the other hand, a component in an electromechanical or early-generation electronic relay may be difficult to find and may hold up repair for weeks. In some situations, the owner may have to resort to a temporary protection panel, or complete panel replacement.

15. Maintenance Activities

Some specific maintenance activities are a requirement to ensure reliability. An example would be that a BES entity could be prudent in its protective relay maintenance, but if its battery maintenance program is lacking, then reliability could still suffer. The NERC glossary outlines a Protection System as containing specific components. PRC-005-6 requires specific maintenance activities be accomplished within a specific time interval. As noted previously, higher technology equipment can contain integral monitoring capability that actually performs maintenance verification activities routinely and often; therefore, *manual intervention* to perform certain activities on these type components may not be needed.

15.1 Protective Relays (Table 1-1)

These relays are defined as the devices that receive the input signal from the current and voltage sensing devices and are used to isolate a Faulted Element of the BES. Devices that sense thermal, vibration, seismic, gas, or any other non-electrical inputs are excluded.

Non-microprocessor based equipment is treated differently than microprocessor-based equipment in the following ways; the relays should meet the asset owners' tolerances:

- Non-microprocessor devices must be tested with voltage and/or current applied to the device.
- Microprocessor devices may be tested through the integral testing of the device.
 - There is no specific protective relay commissioning test or relay routine test mandated.
 - There is no specific documentation mandated.

15.1.1 Frequently Asked Questions:

What calibration tolerance should be applied on electromechanical relays?

Each entity establishes their own acceptable tolerances when applying protective relaying on their system. For some Protection System components, adjustment is required to bring measurement accuracy within the parameters established by the asset owner based on the specific application of the component. A calibration failure is the result if testing finds the specified parameters to be out of tolerance.

15.2 Voltage & Current Sensing Devices (Table 1-3)

These are the current and voltage sensing devices, usually known as instrument transformers. There is presently a technology available (fiber-optic Hall-effect) that does not utilize conventional transformer technology; these devices and other technologies that produce quantities that represent the primary values of voltage and current are considered to be a type of voltage and current sensing devices included in this standard.

The intent of the maintenance activity is to verify the input to the protective relay from the device that produces the current or voltage signal sample.

There is no specific test mandated for these components. The important thing about these signals is to know that the expected output from these components actually reaches the protective relay. Therefore, the proof of the proper operation of these components also demonstrates the integrity of the wiring (or other medium used to convey the signal) from the current and voltage sensing device, all the way to the protective relay. The following observations apply:

- There is no specific ratio test, routine test or commissioning test mandated.
- There is no specific documentation mandated.
- It is required that the signal be present at the relay.
- This expectation can be arrived at from any of a number of means; including, but not limited to, the following: By calculation, by comparison to other circuits, by commissioning tests, by thorough inspection, or by any means needed to verify the circuit meets the asset owner's Protection System maintenance program.
- An example of testing might be a saturation test of a CT with the test values applied at the relay panel; this, therefore, tests the CT, as well as the wiring from the relay all the back to the CT.
- Another possible test is to measure the signal from the voltage and/or current sensing devices, during Load conditions, at the input to the relay.
- Another example of testing the various voltage and/or current sensing devices is to query the microprocessor relay for the Real-time Loading; this can then be compared to other devices to verify the quantities applied to this relay. Since the input devices have supplied the proper values to the protective relay, then the verification activity has been satisfied. Thus, event reports (and oscillographs) can be used to verify that the voltage and current sensing devices are performing satisfactorily.
- Still another method is to measure total watts and vars around the entire bus; this should add up to zero watts and zero vars, thus proving the voltage and/or current sensing devices system throughout the bus.
- Another method for proving the voltage and/or current-sensing devices is to complete commissioning tests on all of the transformers, cabling, fuses and wiring.
- Any other method that verifies the input to the protective relay from the device that produces the current or voltage signal sample.

15.2.1 Frequently Asked Questions:

What is meant by "...verify the current and voltage circuit inputs from the voltage and current sensing devices to the protective relays ..." Do we need to perform ratio, polarity and saturation tests every few years?

No--you must verify that the protective relay is receiving the expected values from the voltage and current-sensing devices (typically voltage and current transformers). This can be as difficult as is proposed by the question (with additional testing on the cabling and substation wiring to ensure that the values arrive at the relays); or simplicity can be achieved by other verification methods. While some examples follow, these are not intended to represent an all-inclusive list; technology advances and ingenuity should not be excluded from making comparisons and verifications:

- Compare the secondary values, at the relay, to a metering circuit, fed by different current transformers, monitoring the same line as the questioned relay circuit.
- Compare the individual phase secondary values at the relay panel (with additional testing on the panel wiring to ensure that the values arrive at those relays) with the other phases, and verify that residual currents are within expected bounds.
- Observe all three phase currents and the residual current at the relay panel with an oscilloscope, observing comparable magnitudes and proper phase relationship, with additional testing on the panel wiring to ensure that the values arrive at the relays.
- Compare the values, as determined by the questioned relay (such as, but not limited to, a query to the microprocessor relay) to another protective relay monitoring the same line, with currents supplied by different CTs.
- Compare the secondary values, at the relay with values measured by test instruments (such as, but not limited to multi-meters, voltmeter, clamp-on ammeters, etc.) and verified by calculations and known ratios to be the values expected. For example, a single PT on a 100 KV bus will have a specific secondary value that, when multiplied by the PT ratio, arrives at the expected bus value of 100 KV.
- Query SCADA for the power flows at the far end of the line protected by the questioned relay, compare those SCADA values to the values as determined by the questioned relay.
- Totalize the Watts and vars on the bus and compare the totals to the values as seen by the questioned relay.

The point of the verification procedure is to ensure that all of the individual components are functioning properly; and that an ongoing proactive procedure is in place to re-check the various components of the protective relay measuring Systems.

Is wiring insulation or hi-pot testing required by this Maintenance Standard?

No--wiring insulation and equipment hi-pot testing are not specifically required by the Maintenance Standard. However, if the method of verifying CT and PT inputs to the relay involves some other method than actual observation of current and voltage transformer secondary inputs to the relay, it might be necessary to perform some sort of cable integrity test to verify that the instrument transformer secondary signals are actually making it to the relay and not being

shunted off to ground. For instance, you could use CT excitation tests and PT turns ratio tests and compare to baseline values to verify that the instrument transformer outputs are acceptable. However, to conclude that these acceptable transformer instrument output signals are actually making it to the relay inputs, it also would be necessary to verify the insulation of the wiring between the instrument transformer and the relay.

My plant generator and transformer relays are electromechanical and do not have metering functions, as do microprocessor-based relays. In order for me to compare the instrument transformer inputs to these relays to the secondary values of other metered instrument transformers monitoring the same primary voltage and current signals, it would be necessary to temporarily connect test equipment, like voltmeters and clamp on ammeters, to measure the input signals to the relays. This practice seems very risky, and a plant trip could result if the technician were to make an error while measuring these current and voltage signals. How can I avoid this risk? Also, what if no other instrument transformers are available which monitor the same primary voltage or current signal?

Comparing the input signals to the relays to the outputs of other independent instrument transformers monitoring the same primary current or voltage is just one method of verifying the instrument transformer inputs to the relays, but is not required by the standard. Plants can choose how to best manage their risk. If online testing is deemed too risky, offline tests, such as, but not limited to, CT excitation test and PT turns ratio tests can be compared to baseline data and be used in conjunction with CT and PT secondary wiring insulation verification tests to adequately “verify the current and voltage circuit inputs from the voltage and current sensing devices to the protective relays...” while eliminating the risk of tripping an in service generator or transformer. Similarly, this same offline test methodology can be used to verify the relay input voltage and current signals to relays when there are no other instrument transformers monitoring available for purposes of signal comparison.

15.3 Control circuitry associated with protective functions (Table 1-5)

This component of Protection Systems includes the trip coil(s) of the circuit breaker, circuit switcher or any other interrupting device. It includes the wiring from the batteries to the relays. It includes the wiring (or other signal conveyance) from every trip output to every trip coil. It includes any device needed for the correct processing of the needed trip signal to the trip coil of the interrupting device; this requirement is meant to capture inputs and outputs to and from a protective relay that are necessary for the correct operation of the protective functions. In short, every trip path must be verified; the method of verification is optional to the asset owner. An example of testing methods to accomplish this might be to verify, with a volt-meter, the existence of the proper voltage at the open contacts, the open circuited input circuit and at the trip coil(s). As every parallel trip path has similar failure modes, each trip path from relay to trip coil must be verified. Each trip coil must be tested to trip the circuit breaker (or other interrupting device) at least once. There is a requirement to operate the circuit breaker (or other interrupting device) at least once every six years as part of the complete functional test. If a suitable monitoring system is installed that verifies every parallel trip path, then the manual-intervention testing of those parallel trip paths can be eliminated; however, the actual operation of the circuit breaker must still occur at least once every six years. This six-year tripping requirement can be completed as easily as tracking the Real-time Fault-clearing operations on the circuit breaker, or tracking the trip coil(s) operation(s) during circuit breaker routine maintenance actions.

The circuit-interrupting device should not be confused with a motor-operated disconnect. The intent of this standard is to require maintenance intervals and activities on Protection Systems equipment, and not just all system isolating equipment.

It is necessary, however, to classify a device that actuates a high-speed auto-closing ground switch as an interrupting device, if this ground switch is utilized in a Protection System and forces a ground Fault to occur that then results in an expected Protection System operation to clear the forced ground Fault. The SDT believes that this is essentially a transferred-tripping device without the use of communications equipment. If this high-speed ground switch is “...designed to provide protection for the BES...” then this device needs to be treated as any other Protection System component. The control circuitry would have to be tested within 12 years, and any electromechanically operated device will have to be tested every six years. If the spring-operated ground switch can be disconnected from the solenoid triggering unit, then the solenoid triggering unit can easily be tested without the actual closing of the ground blade.

The dc control circuitry also includes each auxiliary tripping relay (94) and each lock-out relay (86) that may exist in any particular trip scheme. If the lock-out relays (86) are electromechanical type components, then they must be trip tested. The PSMT SDT considers these components to share some similarities in failure modes as electromechanical protective relays; as such, there is a six-year maximum interval between mandated maintenance tasks unless PBM is applied.

Contacts of the 86 and/or 94 that pass the trip current on to the circuit interrupting device trip coils will have to be checked as part of the 12 year requirement. Contacts of the 86 and/or 94 lock relay that operate non-BES interrupting devices are not required. Normally-open contacts that are not used to pass a trip signal and normally-closed contacts do not have to be verified. Verification of the tripping paths is the requirement.

New technology is also accommodated here; there are some tripping systems that have replaced the traditional hard-wired trip circuitry with other methods of trip-signal conveyance such as fiber-optics. It is the intent of the PSMT SDT to include this, and any other, technology that is used to convey a trip signal from a protective relay to a circuit breaker (or other interrupting device) within this category of equipment. The requirement for these systems is verification of the tripping path.

Monitoring of the control circuit integrity allows for no maintenance activity on the control circuit (excluding the requirement to operate trip coils and electromechanical lockout and/or tripping auxiliary relays). Monitoring of integrity means to monitor for continuity and/or presence of voltage on each trip path. For Ethernet or fiber-optic control systems, monitoring of integrity means to monitor communication ability between the relay and the circuit breaker.

15.3.1 Frequently Asked Questions:

Is it permissible to verify circuit breaker tripping at a different time (and interval) than when we verify the protective relays and the instrument transformers?

Yes--provided the entire Protective System is tested within the individual component's maximum allowable testing intervals.

The Protection System Maintenance Standard describes requirements for verifying the tripping of circuit breakers. What is this telling me about maintenance of circuit breakers?

Requirements in PRC-005-6 are intended to verify the integrity of tripping circuits, including the breaker trip coil, as well as the presence of auxiliary supply (usually a battery) for energizing the trip coil if a protection function operates. Beyond this, PRC-005-6 sets no requirements for verifying circuit breaker performance, or for maintenance of the circuit breaker.

How do I test each dc Control Circuit trip path, as established in Table 1-5 "Protection System Control Circuitry (Trip coils and auxiliary relays)"?

Table 1-5 specifies that each breaker trip coil and lockout relays that carry trip current to a trip coil must be operated within the specified time period. The required operations may be via targeted maintenance activities, or by documented operation of these devices for other purposes such as Fault clearing.

Are high-speed ground switch trip coils included in the dc control circuitry?

Yes--PRC-005-6 includes high-speed grounding switch trip coils within the dc control circuitry to the degree that the initiating Protection Systems are characterized as "transmission Protection Systems."

Does the control circuitry and trip coil of a non-BES breaker, tripped via a BES protection component, have to be tested per Table 1.5? (Refer to Table 3 for examples 1 and 2)

Example 1: A non-BES circuit breaker that is tripped via a Protection System to which PRC-005-6 applies might be (but is not limited to) a 12.5KV circuit breaker feeding (non-black-start) radial Loads but has a trip that originates from an under-frequency (81) relay.

- The relay must be verified.
- The voltage signal to the relay must be verified.
- All of the relevant dc supply tests still apply.
- The unmonitored trip circuit between the relay and any lock-out or auxiliary relay must be verified every 12 years.
- The unmonitored trip circuit between the lock-out (or auxiliary relay) and the non-BES breaker does not have to be proven with an electrical trip.
- In the case where there is no lock-out or auxiliary tripping relay used, the trip circuit to the non-BES breaker does not have to be proven with an electrical trip.
- The trip coil of the non-BES circuit breaker does not have to be individually proven with an electrical trip.

Example 2: A Transmission Owner may have a non-BES breaker that is tripped via a Protection System to which PRC-005-6 applies, which may be (but is not limited to) a 13.8 KV circuit breaker feeding (non-black-start) radial Loads but has a trip that originates from a BES 115KV line relay.

- The relay must be verified
- The voltage signal to the relay must be verified
- All of the relevant dc supply tests still apply

-
- The unmonitored trip circuit between the relay and any lock-out (86) or auxiliary (94) relay must be verified every 12 years
 - The unmonitored trip circuit between the lock-out (86) (or auxiliary (94)) relay and the non-BES breaker does not have to be proven with an electrical trip
 - In the case where there is no lockout (86) or auxiliary (94) tripping relay used, the trip circuit to the non-BES breaker does not have to be proven with an electrical trip.
 - The trip coil of the non-BES circuit breaker does not have to be individually proven with an electrical trip

Example 3: A Generator Owner may have a non-BES circuit breaker that is tripped via a Protection System to which PRC-005-6 applies, such as the generator field breaker and low-side breakers on station service/excitation transformers connected to the generator bus.

Trip testing of the generator field breaker and low side station service/excitation transformer breaker(s) via lockout or auxiliary tripping relays are not required since these breakers may be associated with radially fed loads and are not considered to be BES breakers. An example of an otherwise non-BES circuit breaker that is tripped via a BES protection component might be (but is not limited to) a 6.9kV station service transformer source circuit breaker but has a trip that originates from a generator differential (87) relay.

- The differential relay must be verified.
- The current signals to the relay must be verified.
- All of the relevant dc supply tests still apply.
- The unmonitored trip circuit between the relay and any lock-out or auxiliary relay must be verified every 12 years.
- The unmonitored trip circuit between the lock-out (or auxiliary relay) and the non-BES breaker does not have to be proven with an electrical trip.
- In the case where there is no lock-out or auxiliary tripping relay used, the trip circuit to the non-BES breaker does not have to be proven with an electrical trip.
- The trip coil of the non-BES circuit breaker does not have to be individually proven with an electrical trip.

However, it is very prudent to verify the tripping of such breakers for the integrity of the overall generation plant.

Do I have to verify operation of breaker "a" contacts or any other normally closed auxiliary contacts in the trip path of each breaker as part of my control circuit test?

Operation of normally-closed contacts does not have to be verified. Verification of the tripping paths is the requirement. The continuity of the normally closed contacts will be verified when the tripping path is verified.

15.4 Batteries and DC Supplies (Table 1-4)

The NERC definition of a Protection System is:

- Protective relays which respond to electrical quantities,

-
- Communications Systems necessary for correct operation of protective functions,
 - Voltage and current sensing devices providing inputs to protective relays,
 - Station dc supply associated with protective functions (including station batteries, battery chargers, and non-battery-based dc supply), and
 - Control circuitry associated with protective functions through the trip coil(s) of the circuit breakers or other interrupting devices.

The station battery is not the only component that provides dc power to a Protection System. In the new definition for Protection System, “station batteries” are replaced with “station dc supply” to make the battery charger and dc producing stored energy devices (that are not a battery) part of the Protection System that must be maintained.

The PSMT SDT recognizes that there are several technological advances in equipment and testing procedures that allow the owner to choose how to verify that a battery string is free of open circuits. The term “continuity” was introduced into the standard to allow the owner to choose how to verify continuity of a battery set by various methods, and not to limit the owner to other conventional methods of showing continuity. Continuity, as used in Table 1-4 of the standard, refers to verifying that there is a continuous current path from the positive terminal of the station battery set to the negative terminal. Without verifying continuity of a station battery, there is no way to determine that the station battery is available to supply dc power to the station. An open battery string will be an unavailable power source in the event of loss of the battery charger.

Batteries cannot be a unique population segment of a Performance-Based Maintenance Program (PBM) because there are too many variables in the electrochemical process to completely isolate all of the performance-changing criteria necessary for using PBM on battery Systems. However, nothing precludes the use of a PBM process for any other part of a dc supply besides the batteries themselves.

15.4.1 Frequently Asked Questions:

What constitutes the station dc supply, as mentioned in the definition of Protective System?

The previous definition of Protection System includes batteries, but leaves out chargers. The latest definition includes chargers, as well as dc systems that do not utilize batteries. This revision of PRC-005-6 is intended to capture these devices that were not included under the previous definition. The station direct current (dc) supply normally consists of two components: the battery charger and the station battery itself. There are also emerging technologies that provide a source of dc supply that does not include either a battery or charger.

Battery Charger - The battery charger is supplied by an available ac source. At a minimum, the battery charger must be sized to charge the battery (after discharge) and supply the constant dc load. In many cases, it may be sized also to provide sufficient dc current to handle the higher energy requirements of tripping breakers and switches when actuated by the protective relays in the Protection System.

Station Battery - Station batteries provide the dc power required for tripping and for supplying normal dc power to the station in the event of loss of the battery charger. There are several technologies of battery that require unique forms of maintenance as established in Table 1-4.

Emerging Technologies - Station dc supplies are currently being developed that use other energy storage technologies besides the station battery to prevent loss of the station dc supply when ac power is lost. Maintenance of these station dc supplies will require different kinds of tests and inspections. Table 1-4 presents maintenance activities and maximum allowable testing intervals for these new station dc supply technologies. However, because these technologies are relatively new, the maintenance activities for these station dc supplies may change over time.

What did the PSMT SDT mean by "continuity" of the dc supply?

The PSMT SDT recognizes that there are several technological advances in equipment and testing procedures that allow the owner to choose how to verify that a battery string is free of open circuits. The term "continuity" was introduced into the standard to allow the owner to choose how to verify continuity (no open circuits) of a battery set by various methods, and not to limit the owner to other conventional methods of showing continuity--lack of an open circuit. Continuity, as used in Table 1-4 of the standard, refers to verifying that there is a continuous current path from the positive terminal of the station battery set to the negative terminal (no open circuit). Without verifying continuity of a station battery, there is no way to determine that the station battery is available to supply dc power to the station. Whether it is caused from an open cell or a bad external connection, an open battery string will be an unavailable power source in the event of loss of the battery charger.

The current path through a station battery from its positive to its negative connection to the dc control circuits is composed of two types of elements. These path elements are the electrochemical path through each of its cells and all of the internal and external metallic connections and terminations of the batteries in the battery set. If there is loss of continuity (an open circuit) in any part of the electrochemical or metallic path, the battery set will not be available for service. In the event of the loss of the ac source or battery charger, the battery must be capable of supplying dc current, both for continuous dc loads and for tripping breakers and switches. Without continuity, the battery cannot perform this function.

At generating stations and large transmission stations where battery chargers are capable of handling the maximum current required by the Protection System, there are still problems that could potentially occur when the continuity through the connected battery is interrupted.

- Many battery chargers produce harmonics which can cause failure of dc power supplies in microprocessor-based protective relays and other electronic devices connected to station dc supply. In these cases, the substation battery serves as a filter for these harmonics. With the loss of continuity in the battery, the filter provided by the battery is no longer present.
- Loss of electrical continuity of the station battery will cause, in most battery chargers, regardless of the battery charger's output current capability, a delayed response in full output current from the charger. Almost all chargers have an intentional one- to two-second delay to switch from a low substation dc load current to the maximum output of the charger. This delay would cause the opening of circuit breakers to be delayed, which could violate system performance standards.

Monitoring of the station dc supply voltage will not indicate that there is a problem with the dc current path through the battery, unless the battery charger is taken out of service. At that time,

a break in the continuity of the station battery current path will be revealed because there will be no voltage on the station dc circuitry. This particular test method, while proving battery continuity, may not be acceptable to all installations.

Although the standard prescribes what must be accomplished during the maintenance activity, it does not prescribe how the maintenance activity should be accomplished. There are several methods that can be used to verify the electrical continuity of the battery. These are not the only possible methods, simply a sampling of some methods:

- One method is to measure that there is current flowing through the battery itself by a simple clamp on milliamp-range ammeter. A battery is always either charging or discharging. Even when a battery is charged, there is still a measurable float charge current that can be detected to verify that there is continuity in the electrical path through the battery.
- A simple test for continuity is to remove the battery charger from service and verify that the battery provides voltage and current to the dc system. However, the behavior of the various dc-supplied equipment in the station should be considered before using this approach.
- Manufacturers of microprocessor-controlled battery chargers have developed methods for their equipment to periodically (or continuously) test for battery continuity. For example, one manufacturer periodically reduces the float voltage on the battery until current from the battery to the dc load can be measured to confirm continuity.
- Applying test current (as in some ohmic testing devices, or devices for locating dc grounds) will provide a current that when measured elsewhere in the string, will prove that the circuit is continuous.
- Internal ohmic measurements of the cells and units of lead-acid batteries (VRLA & VLA) can detect lack of continuity within the cells of a battery string; and when used in conjunction with resistance measurements of the battery's external connections, can prove continuity. Also some methods of taking internal ohmic measurements, by their very nature, can prove the continuity of a battery string without having to use the results of resistance measurements of the external connections.
- Specific gravity tests could infer continuity because without continuity there could be no charging occurring; and if there is no charging, then specific gravity will go down below acceptable levels over time.

No matter how the electrical continuity of a battery set is verified, it is a necessary maintenance activity that must be performed at the intervals prescribed by Table 1-4 to insure that the station dc supply has a path that can provide the required current to the Protection System at all times.

When should I check the station batteries to see if they have sufficient energy to perform as manufactured?

The answer to this question depends on the type of battery (valve-regulated lead-acid, vented lead-acid, or nickel-cadmium) and the maintenance activity chosen.

For example, if you have a valve-regulated lead-acid (VRLA) station battery, and you have chosen to evaluate the measured cell/unit internal ohmic values to the battery cell's baseline, you will have to perform verification at a maximum maintenance interval of no greater than

every six months. While this interval might seem to be quite short, keep in mind that the six-month interval is important for VRLA batteries; this interval provides an accumulation of data that better shows when a VRLA battery is incapable of performing as manufactured.

If, for a VRLA station battery, you choose to conduct a performance capacity test on the entire station battery as the maintenance activity, then you will have to perform verification at a maximum maintenance interval of no greater than every three calendar years.

How is a baseline established for cell/unit internal ohmic measurements?

Establishment of cell/unit internal ohmic baseline measurements should be completed when lead-acid batteries are newly installed. To ensure that the baseline ohmic cell/unit values are most indicative of the station battery's ability to perform as manufactured, they should be made at some point in time after the installation to allow the cell chemistry to stabilize after the initial freshening charge. An accepted industry practice for establishing baseline values is after six-months of installation, with the battery fully charged and in service. However, it is recommended that each owner, when establishing a baseline, should consult the battery manufacturer for specific instructions on establishing an ohmic baseline for their product, if available.

When internal ohmic measurements are taken, the same make/model test equipment should be used to establish the baseline and used for the future trending of the cells internal ohmic measurements because of variances in test equipment and the type of ohmic measurement used by different manufacturer's equipment. Keep in mind that one manufacturer's "conductance" test equipment does not produce similar results as another manufacturer's "conductance" test equipment, even though both manufacturers have produced "ohmic" test equipment. Therefore, for meaningful results to an established baseline, the same make/model of instrument should be used.

For all new installations of valve-regulated lead-acid (VRLA) batteries and vented lead-acid (VLA) batteries, where trending of the cells internal ohmic measurements to a baseline are to be used to determine the ability of the station battery to perform as manufactured, the establishment of the baseline, as described above, should be followed at the time of installation to insure the most accurate trending of the cell/unit. However, often for older VRLA batteries, the owners of the station batteries have not established a baseline at installation. Also for owners of VLA batteries who want to establish a maintenance activity which requires trending of measured ohmic values to a baseline, there was typically no baseline established at installation of the station battery to trend to.

To resolve the problem of the unavailability of baseline internal ohmic measurements for the individual cell/unit of a station battery, many manufacturers of internal ohmic measurement devices have established libraries of baseline values for VRLA and VLA batteries using their testing device. Also, several of the battery manufacturers have libraries of baselines for their products that can be used to trend to. However, it is important that when using battery manufacturer-supplied data that it is verified that the baseline readings to be used were taken with the same ohmic testing device that will be used for future measurements (for example "conductance readings" from one manufacturer's test equipment do not correlate to "impedance readings" from a different manufacturer's test equipment). Although many manufacturers may have provided baseline values, which will allow trending of the internal ohmic measurements over the remaining life of a station battery, these baselines are not the actual cell/unit measurements for

the battery being trended. It is important to have a baseline tailored to the station battery to more accurately use the tool of ohmic measurement trending. That more customized baseline can only be created by following the establishment of a baseline for each cell/unit at the time of installation of the station battery.

Why determine the State of Charge?

Even though there is no present requirement to check the state of charge of a battery, it can be a very useful tool in determining the overall condition of a battery system. The following discussions are offered as a general reference.

When a battery is fully charged, the battery is available to deliver its existing capacity. As a battery is discharged, its ability to deliver its maximum available capacity is diminished. It is necessary to determine if the state of charge has dropped to an unacceptable level.

What is State of Charge and how can it be determined in a station battery?

The state of charge of a battery refers to the ratio of residual capacity at a given instant to the maximum capacity available from the battery. When a battery is fully charged, the battery is available to deliver its existing capacity. As a battery is discharged, its ability to deliver its maximum available capacity is diminished. Knowing the amount of energy left in a battery compared with the energy it had when it was fully charged gives the user an indication of how much longer a battery will continue to perform before it needs recharging.

For vented lead-acid (VLA) batteries which use accessible liquid electrolyte, a hydrometer can be used to test the specific gravity of each cell as a measure of its state of charge. The hydrometer depends on measuring changes in the weight of the active chemicals. As the battery discharges, the active electrolyte, sulfuric acid, is consumed and the concentration of the sulfuric acid in water is reduced. This, in turn, reduces the specific gravity of the solution in direct proportion to the state of charge. The actual specific gravity of the electrolyte can, therefore, be used as an indication of the state of charge of the battery. Hydrometer readings may not tell the whole story, as it takes a while for the acid to get mixed up in the cells of a VLA battery. If measured right after charging, you might see high specific gravity readings at the top of the cell, even though it is much less at the bottom. Conversely, if taken shortly after adding water to the cell, the specific gravity readings near the top of the cell will be lower than those at the bottom.

Nickel-cadmium batteries, where the specific gravity of the electrolyte does not change during battery charge and discharge, and valve-regulated lead-acid (VRLA) batteries, where the electrolyte is not accessible, cannot have their state of charge determined by specific gravity readings. For these two types of batteries, and for VLA batteries also, where another method besides taking hydrometer readings is desired, the state of charge may be determined by taking voltage and current readings at the battery terminals. The methods employed to obtain accurate readings vary for the different battery types. Manufacturers' information and IEEE guidelines can be consulted for specifics; (see IEEE 1106 Annex B for Nickel Cadmium batteries, IEEE 1188 Annex A for VRLA batteries and IEEE 450 for VLA batteries).

Why determine the Connection Resistance?

High connection resistance can cause abnormal voltage drop or excessive heating during discharge of a station battery. During periods of a high rate of discharge of the station battery, a very high resistance can cause severe damage. The maintenance requirement to verify battery terminal connection resistance in Table 1-4 is established to verify that the integrity of all battery electrical connections is acceptable. This verification includes cell-to-cell (intercell) and external

circuit terminations. Your method of checking for acceptable values of intercell and terminal connection resistance could be by individual readings, or a combination of the two. There are test methods presently that can read post termination resistances and resistance values between external posts. There are also test methods presently available that take a combination reading of the post termination connection resistance plus the intercell resistance value plus the post termination connection resistance value. Either of the two methods, or any other method, that can show if the adequacy of connections at the battery posts is acceptable.

Adequacy of the electrical terminations can be determined by comparing resistance measurements for all connections taken at the time of station battery's installation to the same resistance measurements taken at the maintenance interval chosen, not to exceed the maximum maintenance interval of Table 1-4. Trending of the interval measurements to the baseline measurements will identify any degradation in the battery connections. When the connection resistance values exceed the acceptance criteria for the connection, the connection is typically disassembled, cleaned, reassembled and measurements taken to verify that the measurements are adequate when compared to the baseline readings.

What conditions should be inspected for visible battery cells?

The maintenance requirement to inspect the cell condition of all station battery cells where the cells are visible is a maintenance requirement of Table 1-4. Station batteries are different from any other component in the Protection Station because they are a perishable product due to the electrochemical process which is used to produce dc electrical current and voltage. This inspection is a detailed visual inspection of the cells for abnormalities that occur in the aging process of the cell. In VLA battery visual inspections, some of the things that the inspector is typically looking for on the plates are signs of sulfation of the plates, abnormal colors (which are an indicator of sulfation or possible copper contamination) and abnormal conditions such as cracked grids. The visual inspection could look for symptoms of hydration that would indicate that the battery has been left in a completely discharged state for a prolonged period. Besides looking at the plates for signs of aging, all internal connections, such as the bus bar connection to each plate, and the connections to all posts of the battery need to be visually inspected for abnormalities. In a complete visual inspection for the condition of the cell the cell plates, separators and sediment space of each cell must be looked at for signs of deterioration. An inspection of the station battery's cell condition also includes looking at all terminal posts and cell-to-cell electric connections to ensure they are corrosion free. The case of the battery containing the cell, or cells, must be inspected for cracks and electrolyte leaks through cracks and the post seals.

This maintenance activity cannot be extended beyond the maximum maintenance interval of Table 1-4 by a Performance-Based Maintenance Program (PBM) because of the electrochemical aging process of the station battery, nor can there be any monitoring associated with it because there must be a visual inspection involved in the activity. A remote visual inspection could possibly be done, but its interval must be no greater than the maximum maintenance interval of Table 1-4.

Why is it necessary to verify the battery string can perform as manufactured? I only care that the battery can trip the breaker, which means that the battery can perform as designed. I oversize my batteries so that even if the battery cannot perform as manufactured, it can still trip my breakers.

The fundamental answer to this question revolves around the concept of battery performance “as designed” vs. battery performance “as manufactured.” The purpose of the various sections of Table 1-4 of this standard is to establish requirements for the Protection System owner to maintain the batteries, to ensure they will operate the equipment when there is an incident that requires dc power, and ensure the batteries will continue to provide adequate service until at least the next maintenance interval. To meet these goals, the correct battery has to be properly selected to meet the design parameters, and the battery has to deliver the power it was manufactured to provide.

When testing batteries, it may be difficult to determine the original design (i.e., load profile) of the dc system. This standard is not intended as a design document, and requirements relating to design are, therefore, not included.

Where the dc load profile is known, the best way to determine if the system will operate as designed is to conduct a service test on the battery. However, a service test alone might not fully determine if the battery is healthy. A battery with 50% capacity may be able to pass a service test, but the battery would be in a serious state of deterioration and could fail at some point in the near future.

To ensure that the battery will meet the required load profile and continue to meet the load profile until the next maintenance interval, the installed battery must be sized correctly (i.e., a correct design), and it must be in a good state of health. Since the design of the dc system is not within the scope of the standard, the only consistent and reliable method to ensure that the battery is in a good state of health is to confirm that it can perform as manufactured. If the battery can perform as manufactured and it has been designed properly, the system should operate properly until the next maintenance interval.

How do I verify the battery string can perform as manufactured?

Optimally, actual battery performance should be verified against the manufacturer’s rating curves. The best practice for evaluating battery performance is via a performance test. However, due to both logistical and system reliability concerns, some Protection System owners prefer other methods to determine if a battery can perform as manufactured. There are several battery parameters that can be evaluated to determine if a battery can perform as manufactured. Ohmic measurements and float current are two examples of parameters that have been reported to assist in determining if a battery string can perform as manufactured.

The evaluation of battery parameters in determining battery health is a complex issue, and is not an exact science. This standard gives the user an opportunity to utilize other measured parameters to determine if the battery can perform as manufactured. It is the responsibility of the Protection System owner, however, to maintain a documented process that demonstrates the chosen parameter(s) and associated methodology used to determine if the battery string can perform as manufactured.

Whatever parameters are used to evaluate the battery (ohmic measurements, float current, float voltages, temperature, specific gravity, performance test, or combination thereof), the goal is to determine the value of the measurement (or the percentage change) at which the battery fails to perform as manufactured, or the point where the battery is deteriorating so rapidly that it will not perform as manufactured before the next maintenance interval.

This necessitates the need for establishing and documenting a baseline. A baseline may be required of every individual cell, a particular battery installation, or a specific make, model, or size of a cell. Given a consistent cell manufacturing process, it may be possible to establish a baseline number for the cell (make/model/type) and, therefore, a subsequent baseline for every installation would not be necessary. However, future installations of the same battery types should be spot-checked to ensure that your baseline remains applicable.

Consistent testing methods by trained personnel are essential. Moreover, it is essential that these technicians utilize the same make/model of ohmic test equipment each time readings are taken in order to establish a meaningful and accurate trend line against the established baseline. The type of probe and its location (post, connector, etc.) for the reading need to be the same for each subsequent test. The room temperature should be recorded with the readings for each test as well. Care should be taken to consider any factors that might lead a trending program to become invalid.

Float current along with other measurable parameters can be used in lieu of or in concert with ohmic measurement testing to measure the ability of a battery to perform as manufactured. The key to using any of these measurement parameters is to establish a baseline and the point where the reading indicates that the battery will not perform as manufactured.

The establishment of a baseline may be different for various types of cells and for different types of installations. In some cases, it may be possible to obtain a baseline number from the battery manufacturer, although it is much more likely that the baseline will have to be established after the installation is complete. To some degree, the battery may still be “forming” after installation; consequently, determining a stable baseline may not be possible until several months after the battery has been in service.

The most important part of this process is to determine the point where the ohmic reading (or other measured parameter(s)) indicates that the battery cannot perform as manufactured. That point could be an absolute number, an absolute change, or a percentage change of an established baseline.

Since there are no universally-accepted repositories of this information, the Protection System owner will have to determine the value/percentage where the battery cannot perform as manufactured (heretofore referred to as a failed cell). This is the most difficult and important part of the entire process.

To determine the point where the battery fails to perform as manufactured, it is helpful to have a history of a battery type, if the data includes the parameter(s) used to evaluate the battery's ability to perform as manufactured against the actual demonstrated performance/capacity of a battery/cell.

For example, when an ohmic reading has been recorded that the user suspects is indicating a failed cell, a performance test of that cell (or string) should be conducted in order to prove/quantify that the cell has failed. Through this process, the user needs to determine the ohmic value at which the performance of the cell has dropped below 80% of the manufactured, rated performance. It is likely that there may be a variation in ohmic readings that indicates a failed cell (possibly significant). It is prudent to use the most conservative values to determine the point at which the cell should be marked for replacement. Periodically, the user should

demonstrate that an “adequate” ohmic reading equates to an adequate battery performance (>80% of capacity).

Similarly, acceptance criteria for "good" and "failed" cells should be established for other parameters such as float current, specific gravity, etc., if used to determine the ability of a battery to function as designed.

What happens if I change the make/model of ohmic test equipment after the battery has been installed for a period of time?

If a user decides to switch testers, either voluntarily or because the equipment is not supported/sold any longer, the user may have to establish a new base line and new parameters that indicate when the battery no longer performs as manufactured. The user always has a choice to perform a capacity test in lieu of establishing new parameters.

What are some of the differences between lead-acid and nickel-cadmium batteries?

There is a marked difference in the aging process of lead acid and nickel-cadmium station batteries. The difference in the aging process of these two types of batteries is chiefly due to the electrochemical process of the battery type. Aging and eventual failure of lead acid batteries is due to expansion and corrosion of the positive grid structure, loss of positive plate active material, and loss of capacity caused by physical changes in the active material of the positive plates. In contrast, the primary failure of nickel-cadmium batteries is due to the gradual linear aging of the active materials in the plates. The electrolyte of a nickel-cadmium battery only facilitates the chemical reaction (it functions only to transfer ions between the positive and negative plates), but is not chemically altered during the process like the electrolyte of a lead acid battery. A lead acid battery experiences continued corrosion of the positive plate and grid structure throughout its operational life while a nickel-cadmium battery does not.

Changes to the properties of a lead acid battery when periodically measured and trended to a baseline, can indicate aging of the grid structure, positive plate deterioration, or changes in the active materials in the plate.

Because of the clear differences in the aging process of lead acid and nickel-cadmium batteries, there are no significantly measurable properties of the nickel-cadmium battery that can be measured at a periodic interval and trended to determine aging. For this reason, Table 1-4(c) (Protection System Station dc supply Using nickel-cadmium [NiCad] Batteries) only specifies one minimum maintenance activity and associated maximum maintenance interval necessary to verify that the station battery can perform as manufactured by evaluating cell/unit measurements indicative of battery performance against the station battery baseline. This maintenance activity is to conduct a performance or modified performance capacity test of the entire battery bank.

Why in Table 1-4 of PRC-005-6 is there a maintenance activity to inspect the structural integrity of the battery rack?

The purpose of this inspection is to verify that the battery rack is correctly installed and has no deterioration that could weaken its structural integrity.

Because the battery rack is specifically manufactured for the battery that is mounted on it, weakening of its structural members by rust or corrosion can physically jeopardize the battery.

What is required to comply with the "Unintentional dc Grounds" requirement?

In most cases, the first ground that appears on a battery is not a problem. It is the unintentional ground that appears on the opposite pole that becomes problematic. Even then many systems are designed to operate favorably under some unintentional dc ground situations. It is up to the owner of the Protection System to determine if corrective actions are needed on detected unintentional dc grounds. The standard merely requires that a check be made for the existence of unintentional dc grounds. Obviously, a “check-off” of some sort will have to be devised by the inspecting entity to document that a check is routinely done for unintentional dc grounds because of the possible consequences to the Protection System.

Where the standard refers to "all cells," is it sufficient to have a documentation method that refers to "all cells," or do we need to have separate documentation for every cell? For example, do I need 60 individual documented check-offs for good electrolyte level, or would a single check-off per bank be sufficient?

A single check-off per battery bank is sufficient for documentation, as long as the single check-off attests to checking all cells/units.

Does this standard refer to Station batteries or all batteries; for example, Communications Site Batteries?

This standard refers to Station Batteries. The drafting team does not believe that the scope of this standard refers to communications sites. The batteries covered under PRC-005-6 are the batteries that supply the trip current to the trip coils of the interrupting devices that are a part of the Protection System. The SDT believes that a loss of power to the communications systems at a remote site would cause the communications systems associated with protective relays to alarm at the substation. At this point, the corrective actions can be initiated.

What are cell/unit internal ohmic measurements?

With the introduction of Valve-Regulated Lead-Acid (VRLA) batteries to station dc supplies in the 1980's several of the standard maintenance tools that are used on Vented Lead-Acid (VLA) batteries were unable to be used on this new type of lead-acid battery to determine its state of health. The only tools that were available to give indication of the health of these new VRLA batteries were voltage readings of the total battery voltage, the voltage of the individual cells and periodic discharge tests.

In the search for a tool for determining the health of a VRLA battery several manufacturers studied the electrical model of a lead acid battery's current path through its cell. The overall battery current path consists of resistance and inductive and capacitive reactance. The inductive reactance in the current path through the battery is so minuscule when compared to the huge capacitive reactance of the cells that it is often ignored in most circuit models of the battery cell. Taking the basic model of a battery cell manufacturers of battery test equipment have developed and marketed testing devices to take measurements of the current path to detect degradation in the internal path through the cell.

In the battery industry, these various types of measurements are referred to as ohmic measurements. Terms used by the industry to describe ohmic measurements are ac conductance, ac impedance, and dc resistance. They are defined by the test equipment providers and IEEE and refer to the method of taking ohmic measurements of a lead acid battery. For example, in one manufacturer's ac conductance equipment measurements are taken by applying a voltage of a known frequency and amplitude across a cell or battery unit and observing the ac

current flow it produces in response to the voltage. A manufacturer of an ac impedance meter measures ac current of a known frequency and amplitude that is passed through the whole battery string and determines the impedances of each cell or unit by measuring the resultant ac voltage drop across them. On the other hand, dc resistance of a cell is measured by a third manufacturer's equipment by applying a dc load across the cell or unit and measuring the step change in both the voltage and current to calculate the internal dc resistance of the cell or unit.

It is important to note that because of the rapid development of the market for ohmic measurement devices, there were no standards developed or used to mandate the test signals used in making ohmic measurements. Manufacturers using proprietary methods and applying different frequencies and magnitudes for their signals have developed a diversity of measurement devices. This diversity in test signals coupled with the three different types of ohmic measurements techniques (impedance conductance and resistance) make it impossible to always get the same ohmic measurement for a cell with different ohmic measurement devices. However, IEEE has recognized the great value for choosing one device for ohmic measurement, no matter who makes it or the method to calculate the ohmic measurement. The only caution given by IEEE and the battery manufacturers is that when trending the cells of a lead acid station battery consistent ohmic measurement devices should be used to establish the baseline measurement and to trend the battery set for its entire life.

For VRLA batteries both IEEE Standard 1188 (Maintenance, Testing and Replacement of VRLA Batteries) and IEEE Standard 1187 (Installation Design and Installation of VRLA Batteries) recognize the importance of the maintenance activity of establishing a baseline for "cell/unit internal ohmic measurements (impedance, conductance and resistance)" and trending them at frequent intervals over the life of the battery. There are extensive discussions about the need for taking these measurements in these standards. IEEE Standard 1188 requires taking internal ohmic values as described in Annex C4 during regular inspections of the station battery. For VRLA batteries IEEE Standard 1188 in talking about the necessity of establishing a baseline and trending it over time says, "...depending on the degree of change a performance test, cell replacement or other corrective action may be necessary..." (IEEE std 1188-2005, C.4 page 18).

For VLA batteries IEEE Standard 484 (Installation of VLA batteries) gives several guidelines about establishing baseline measurements on newly installed lead acid stationary batteries. The standard also discusses the need to look for significant changes in the ohmic measurements, the caution that measurement data will differ with each type of model of instrument used, and lists a number of factors that affect ohmic measurements.

At the beginning of the 21st century, EPRI conducted a series of extensive studies to determine the relationship of internal ohmic measurements to the capacity of a lead acid battery cell. The studies indicated that internal ohmic measurements were in fact a good indicator of a lead acid battery cell's capacity, but because users often were only interested in the total station battery capacity and the technology does not precisely predict overall battery capacity, if a user only needs "an accurate measure of the overall battery capacity," they should "perform a battery capacity test."

Prior to the EPRI studies some large and small companies which owned and maintained station dc supplies in NERC Protection Systems developed maintenance programs where trending of ohmic measurements of cells/units of the station's battery became the maintenance activity for determining if the station battery could perform as manufactured. By evaluation of the trending

of the ohmic measurements over time, the owner could track the performance of the individual components of the station battery and determine if a total station battery or components of it required capacity testing, removal, replacement or in many instances replacement of the entire station battery. By taking this condition based approach these owners have eliminated having to perform capacity testing at prescribed intervals to determine if a battery needs to be replaced and are still able to effectively determine if a station battery can perform as manufactured.

My VRLA batteries have multiple-cells within an individual battery jar (or unit); how am I expected to comply with the cell-to-cell ohmic measurement requirements on these units that I cannot get to?

Measurement of cell/unit (not all batteries allow access to “individual cells” some “units” or jars may have multiple cells within a jar) internal ohmic values of all types of lead acid batteries where the cells of the battery are not visible is a station dc supply maintenance activity in Table 1-4. In cases where individual cells in a multi-cell unit are inaccessible, an ohmic measurement of the entire unit may be made.

I have a concern about my batteries being used to support additional auxiliary loads beyond my protection control systems in a generation station. Is ohmic measurement testing sufficient for my needs?

While this standard is focused on addressing requirements for Protection Systems, if batteries are used to service other load requirements beyond that of Protection Systems (e.g. pumps, valves, inverter loads), the functional entity may consider additional testing to confirm that the capacity of the battery is sufficient to support all loads.

Why verify voltage?

There are two required maintenance activities associated with verification of dc voltages in Table 1-4. These two required activities are to verify station dc supply voltage and float voltage of the battery charger, and have different maximum maintenance intervals. Both of these voltage verification requirements relate directly to the battery charger maintenance.

The verification of the dc supply voltage is simply an observation of battery voltage to prove that the charger has not been lost or is not malfunctioning; a reading taken from the battery charger panel meter or even SCADA values of the dc voltage could be some of the ways that one could satisfy the requirements. Low battery voltage below float voltage indicates that the battery may be on discharge and, if not corrected, the station battery could discharge down to some extremely low value that will not operate the Protection System. High voltage, close to or above the maximum allowable dc voltage for equipment connected to the station dc supply indicates the battery charger may be malfunctioning by producing high dc voltage levels on the Protection System. If corrective actions are not taken to bring the high voltage down, the dc power supplies and other electronic devices connected to the station dc supply may be damaged. The maintenance activity of verifying the float voltage of the battery charger is not to prove that a charger is lost or producing high voltages on the station dc supply, but rather to prove that the charger is properly floating the battery within the proper voltage limits. As above, there are many ways that this requirement can be met.

Why check for the electrolyte level?

In vented lead-acid (VLA) and nickel-cadmium (NiCad) batteries the visible electrolyte level must be checked as one of the required maintenance activities that must be performed at an interval that is equal to or less than the maximum maintenance interval of Table 1-4. Because the electrolyte level in valve-regulated lead-acid (VRLA) batteries cannot be observed, there is no maintenance activity listed in Table 1-4 of the standard for checking the electrolyte level. Low electrolyte level of any cell of a VLA or NiCad station battery is a condition requiring correction. Typically, the electrolyte level should be returned to an acceptable level for both types of batteries (VLA and NiCad) by adding distilled or other approved-quality water to the cell.

Often people confuse the interval for watering all cells required due to evaporation of the electrolyte in the station battery cells with the maximum maintenance interval required to check the electrolyte level. In many of the modern station batteries, the jar containing the electrolyte is so large with the band between the high and low electrolyte level so wide that normal evaporation which would require periodic watering of all cells takes several years to occur. However, because loss of electrolyte due to cracks in the jar, overcharging of the station battery, or other unforeseen events can cause rapid loss of electrolyte; the shorter maximum maintenance intervals for checking the electrolyte level are required. A low level of electrolyte in a VLA battery cell which exposes the tops of the plates can cause the exposed portion of the plates to accelerated sulfation resulting in loss of cell capacity. Also, in a VLA battery where the electrolyte level goes below the end of the cell withdrawal tube or filling funnel, gasses can exit the cell by the tube instead of the flame arrester and present an explosion hazard.

What are the parameters that can be evaluated in Tables 1-4(a) and 1-4(b)?

The most common parameter that is periodically trended and evaluated by industry today to verify that the station battery can perform as manufactured is internal ohmic cell/unit measurements.

In the mid-1990s, several large and small utilities began developing maintenance and testing programs for Protection System station batteries using a condition based maintenance approach of trending internal ohmic measurements to each station battery cell's baseline value. Battery owners use the data collected from this maintenance activity to determine (1) when a station battery requires a capacity test (instead of performing a capacity test on a predetermined, prescribed interval), (2) when an individual cell or battery unit should be replaced, or (3) based on the analysis of the trended data, if the station battery should be replaced without performing a capacity test.

Other examples of measurable parameters that can be periodically trended and evaluated for lead acid batteries are cell voltage, float current, connection resistance. However, periodically trending and evaluating cell/unit Ohmic measurements are the most common battery/cell parameters that are evaluated by industry to verify a lead acid battery string can perform as manufactured.

Why does it appear that there are two maintenance activities in Table 1-4(b) (for VRLA batteries) that appear to be the same activity and have the same maximum maintenance interval?

There are two different and distinct reasons for doing almost the same maintenance activity at the same interval for valve-regulated lead-acid (VRLA) batteries. The first similar activity for VRLA

batteries (Table 1-4(b)) that has the same maximum maintenance interval is to “measure battery cell/unit internal ohmic values.” Part of the reason for this activity is because the visual inspection of the cell condition is unavailable for VRLA batteries. Besides the requirement to measure the internal ohmic measurements of VRLA batteries to determine the internal health of the cell, the maximum maintenance interval for this activity is significantly shorter than the interval for vented lead-acid (VLA) due to some unique failure modes for VRLA batteries. Some of the potential problems that VRLA batteries are susceptible to that do not affect VLA batteries are thermal runaway, cell dry-out, and cell reversal when one cell has a very low capacity.

The other similar activity listed in Table 1-4(b) is “...verify that the station battery can perform as manufactured by evaluating the measured cell/unit measurements indicative of battery performance (e.g. internal ohmic values) against the station battery baseline.” This activity allows an owner the option to choose between this activity with its much shorter maximum maintenance interval or the longer maximum maintenance interval for the maintenance activity to “Verify that the station battery can perform as manufactured by conducting a performance or modified performance capacity test of the entire battery bank.”

For VRLA batteries, there are two drivers for internal ohmic readings. The first driver is for a means to trend battery life. Trending against the baseline of VRLA cells in a battery string is essential to determine the approximate state of health of the battery. Ohmic measurement testing may be used as the mechanism for measuring the battery cells. If all the cells in the string exhibit a consistent trend line and that trend line has not risen above a specific deviation (e.g. 30%) over baseline for impedance tests or below baseline for conductance tests, then a judgment can be made that the battery is still in a reasonably good state of health and able to ‘perform as manufactured.’ It is essential that the specific deviation mentioned above is based on data (test or otherwise) that correlates the ohmic readings for a specific battery/tester combination to the health of the battery. This is the intent of the “perform as manufactured six-month test” at Row 4 on Table 1-4b.

The second big driver is VRLA batteries tendency for thermal runaway. This is the intent of the “thermal runaway test” at Row 2 on Table 1-4b. In order to detect a cell in thermal runaway, you need not necessarily have a formal trending program. When a single cell/unit changes significantly or significantly varies from the other cells (e.g. a doubling of resistance/impedance or a 50% decrease in conductance), there is a high probability that the cell/unit/string needs to be replaced as soon as possible. In other words, if the battery is 10 years old and all the cells have approached a significant change in ohmic values over baseline, then you have a battery which is approaching end of life. You need to get ready to buy a new battery, but you do not have to worry about an impending catastrophic failure. On the other hand, if the battery is five years old and you have one cell that has a markedly different ohmic reading than all the other cells, then you need to be worried that this cell is susceptible to thermal runaway. If the float (charging) current has risen significantly and the ohmic measurement has increased/decreased as described above then concern of catastrophic failure should trigger attention for corrective action.

If an entity elects to use a capacity test rather than a cell ohmic value trending program, this does not eliminate the need to be concerned about thermal runaway--the entity still needs to do the six-month readings and look for cells which are outliers in the string but they need not trend

results against the factory/as new baseline. Some entities will not mind the extra administrative burden of having the ongoing trending program against baseline--others would rather just do the capacity test and not have to trend the data against baseline. Nonetheless, all entities must look for ohmic outliers on a six-month basis.

It is possible to accomplish both tasks listed (trend testing for capability and testing for thermal runaway candidates) with the very same ohmic test. It becomes an analysis exercise of watching the trend from baselines and watching for the oblique cell measurement.

In table 1-4(f) (Exclusions for Protection System Station dc Supply Monitoring Devices and Systems), must all component attributes listed in the table be met before an exclusion can be granted for a maintenance activity?

Table 1-4(f) was created by the drafting team to allow Protection System dc supply owners to obtain exclusions from periodic maintenance activities by using monitoring devices. The basis of the exclusions granted in the table is that the monitoring devices must incorporate the monitoring capability of microprocessor based components which perform continuous self-monitoring. For failure of the microprocessor device used in dc supply monitoring, the self-checking routine in the microprocessor must generate an alarm which will be reported within 24 hours of device failure to a location where corrective action can be initiated.

Table 1-4(f) lists 8 component attributes along with a specific periodic maintenance activity associated with each of the 8 attributes listed. If an owner of a station dc supply wants to be excluded from periodically performing one of the 8 maintenance activities listed in table 1-4(f), the owner must have evidence that the monitoring and alarming component attributes associated with the excluded maintenance activity are met by the self-checking microprocessor based device with the specific component attribute listed in the table 1-4(f).

For example if an owner of a VLA station battery does not want to “verify station dc supply voltage” every “4 calendar months” (see table 1-4(a)), the owner can install a monitoring and alarming device “with high and low voltage monitoring and alarming of the battery charger voltage to detect charger overvoltage and charger failure” and “no periodic verification of station dc supply voltage is required” (see table 1-4(f) first row). However, if for the same Protection System discussed above, the owner does not install “electrolyte level monitoring and alarming in every cell” and “unintentional dc ground monitoring and alarming” (see second and third rows of table 1-4(f)), the owner will have to “inspect electrolyte level and for unintentional grounds” every “4 calendar months” (see table 1-4(a)).

15.5 Associated communications equipment (Table 1-2)

The equipment used for tripping in a communications-assisted trip scheme is a vital piece of the trip circuit. Remote action causing a local trip can be thought of as another parallel trip path to the trip coil that must be tested. Besides the trip output and wiring to the trip coil(s), there is also a communications medium that must be maintained. Newer technologies now exist that achieve communications-assisted tripping without the conventional wiring practices of older technology. For example, older technologies may have included Frequency Shift Key methods. This technology requires that guard and trip levels be maintained. The actual tripping path(s) to

the trip coil(s) may be tested as a parallel trip path within the dc control circuitry tests. Emerging technologies transfer digital information over a variety of carrier mediums that are then interpreted locally as trip signals. The requirements apply to the communicated signal needed for the proper operation of the protective relay trip logic or scheme. Therefore, this standard is applied to equipment used to convey both trip signals (permissive or direct) and block signals.

It was the intent of this standard to require that a test be performed on any communications-assisted trip scheme, regardless of the vintage of technology. The essential element is that the tripping (or blocking) occurs locally when the remote action has been asserted; or that the tripping (or blocking) occurs remotely when the local action is asserted. Note that the required testing can still be done within the concept of testing by overlapping segments. Associated communications equipment can be (but is not limited to) testing at other times and different frequencies as the protective relays, the individual trip paths and the affected circuit interrupting devices.

Some newer installations utilize digital signals over fiber-optics from the protective relays in the control house to the circuit interrupting device in the yard. This method of tripping the circuit breaker, even though it might be considered communications, must be maintained per the dc control circuitry maintenance requirements.

15.5.1 Frequently Asked Questions:

What are some examples of mechanisms to check communications equipment functioning?

For unmonitored Protection Systems, various types of communications systems will have different facilities for on-site integrity checking to be performed at least every four months during a substation visit. Some examples are, but not limited to:

- On-off power-line carrier systems can be checked by performing a manual carrier keying test between the line terminals, or carrier check-back test from one terminal.
- Systems which use frequency-shift communications with a continuous guard signal (over a telephone circuit, analog microwave system, etc.) can be checked by observing for a loss-of-guard indication or alarm. For frequency-shift power-line carrier systems, the guard signal level meter can also be checked.
- Hard-wired pilot wire line Protection Systems typically have pilot-wire monitoring relays that give an alarm indication for a pilot wire ground or open pilot wire circuit loop.
- Digital communications systems typically have a data reception indicator or data error indicator (based on loss of signal, bit error rate, or frame error checking).

For monitored Protection Systems, various types of communications systems will have different facilities for monitoring the presence of the communications channel, and activating alarms that can be monitored remotely. Some examples are, but not limited to:

- On-off power-line carrier systems can be shown to be operational by automated periodic power-line carrier check-back tests with remote alarming of failures.

-
- Systems which use a frequency-shift communications with a continuous guard signal (over a telephone circuit, analog microwave system, etc.) can be remotely monitored with a loss-of-guard alarm or low signal level alarm.
 - Hard-wired pilot wire line Protection Systems can be monitored by remote alarming of pilot-wire monitoring relays.
 - Digital communications systems can activate remotely monitored alarms for data reception loss or data error indications.
 - Systems can be queried for the data error rates.

For the highest degree of monitoring of Protection Systems, the communications system must monitor all aspects of the performance and quality of the channel that show it meets the design performance criteria, including monitoring of the channel interface to protective relays.

- In many communications systems signal quality measurements, including signal-to-noise ratio, received signal level, reflected transmitter power or standing wave ratio, propagation delay, and data error rates are compared to alarm limits. These alarms are connected for remote monitoring.
- Alarms for inadequate performance are remotely monitored at all times, and the alarm communications system to the remote monitoring site must itself be continuously monitored to assure that the actual alarm status at the communications equipment location is continuously being reflected at the remote monitoring site.

What is needed for the four-month inspection of communications-assisted trip scheme equipment?

The four-month inspection applies to unmonitored equipment. An example of compliance with this requirement might be, but is not limited to:

With each site visit, check that the equipment is free from alarms; check any metered signal levels, and that power is still applied. While this might be explicit for a particular type of equipment (i.e., FSK equipment), the concept should be that the entity verify that the communications equipment that is used in a Protection System is operable through a cursory inspection and site visit. This site visit can be eliminated on this particular example if the FSK equipment had a monitored alarm on Loss of Guard. Blocking carrier systems with auto checkbacks will present an alarm when the channel fails allowing a visual indication. With no auto checkback, the channel integrity will need to be verified by a manual checkback or a two ended signal check. This check could also be eliminated by bring the auto checkback failure alarm to the monitored central location.

Does a fiber optic I/O scheme used for breaker tripping or control within a station, for example - transmitting a trip signal or control logic between the control house and the breaker control cabinet, constitute a communications system?

This equipment is presently classified as being part of the Protection System control circuitry and tested per the portions of Table 1 applicable to “Protection System Control Circuitry”, rather than those portions of the table applicable to communications equipment.

What is meant by "Channel" and "Communications Systems" in Table 1-2?

The transmission of logic or data from a relay in one station to a relay in another station for use in a pilot relay scheme will require a communications system of some sort. Typical relay

communications systems use fiber optics, leased audio channels, power line carrier, and microwave. The overall communications system includes the channel and the associated communications equipment.

This standard refers to the “channel” as the medium between the transmitters and receivers in the relay panels such as a leased audio or digital communications circuit, power line and power line carrier auxiliary equipment, and fiber. The dividing line between the channel and the associated communications equipment is different for each type of media.

Examples of the Channel:

- Power Line Carrier (PLC) - The PLC channel starts and ends at the PLC transmitter and receiver output unless there is an internal hybrid. The channel includes the external hybrids, tuners, wave traps and the power line itself.
- Microwave –The channel includes the microwave multiplexers, radios, antennae and associated auxiliary equipment. The audio tone and digital transmitters and receivers in the relay panel are the associated communications equipment.

Digital/Audio Circuit – The channel includes the equipment within and between the substations. The associated communications equipment includes the relay panel transmitters and receivers and the interface equipment in the relays.

- Fiber Optic – The channel starts at the fiber optic connectors on the fiber distribution panel at the local station and goes to the fiber optic distribution panel at the remote substation. The jumpers that connect the relaying equipment to the fiber distribution panel and any optical-electrical signal format converters are the associated communications equipment.

Figure 1-2, A-1 and A-2 at the end of this document show good examples of the communications channel and the associated communications equipment.

In Table 1-2, the Maintenance Activities section of the Protection System Communications Equipment and Channels refers to the quality of the channel meeting "performance criteria." What is meant by performance criteria?

Protection System communications channels must have a means of determining if the channel and communications equipment is operating normally. If the channel is not operating normally, an alarm will be indicated. For unmonitored systems, this alarm will probably be on the panel. For monitored systems, the alarm will be transmitted to a remote location.

Each entity will have established a nominal performance level for each Protection System communications channel that is consistent with proper functioning of the Protection System. If that level of nominal performance is not being met, the system will go into alarm. Following are some examples of Protection System communications channel performance measuring:

- For direct transfer trip using a frequency shift power line carrier channel, a guard level monitor is part of the equipment. A normal receive level is established when the system is calibrated and if the signal level drops below an established level, the system will indicate an alarm.

-
- An on-off blocking signal over power line carrier is used for directional comparison blocking schemes on transmission lines. During a Fault, block logic is sent to the remote relays by turning on a local transmitter and sending the signal over the power line to a receiver at the remote end. This signal is normally off so continuous levels cannot be checked. These schemes use check-back testing to determine channel performance. A predetermined signal sequence is sent to the remote end and the remote end decodes this signal and sends a signal sequence back. If the sending end receives the correct information from the remote terminal, the test passes and no alarm is indicated. Full power and reduced power tests are typically run. Power levels for these tests are determined at the time of calibration.
 - Pilot wire relay systems use a hardwire communications circuit to communicate between the local and remote ends of the protective zone. This circuit is monitored by circulating a dc current between the relay systems. A typical level may be 1 mA. If the level drops below the setting of the alarm monitor, the system will indicate an alarm.
 - Modern digital relay systems use data communications to transmit relay information to the remote end relays. An example of this is a line current differential scheme commonly used on transmission lines. The protective relays communicate current magnitude and phase information over the communications path to determine if the Fault is located in the protective zone. Quantities such as digital packet loss, bit error rate and channel delay are monitored to determine the quality of the channel. These limits are determined and set during relay commissioning. Once set, any channel quality problems that fall outside the set levels will indicate an alarm.

The previous examples show how some protective relay communications channels can be monitored and how the channel performance can be compared to performance criteria established by the entity. This standard does not state what the performance criteria will be; it just requires that the entity establish nominal criteria so Protection System channel monitoring can be performed.

How is the performance criteria of Protection System communications equipment involved in the maintenance program?

An entity determines the acceptable performance criteria, depending on the technology implemented. If the communications channel performance of a Protection System varies from the pre-determined performance criteria for that system, then these results should be investigated and resolved.

How do I verify the A/D converters of microprocessor-based relays?

There are a variety of ways to do this. Two examples would be: using values gathered via data communications and automatically comparing these values with values from other sources, or using groupings of other measurements (such as vector summation of bus feeder currents) for comparison. Many other methods are possible.

15.6 Alarms (Table 2)

In addition to the tables of maintenance for the components of a Protection System, there is an additional table added for alarms. This additional table was added for clarity. This enabled the common alarm attributes to be consolidated into a single spot, and, thus, make it easier to read the Tables 1-1 through 1-5, Table 3, and Table 4. The alarms need to arrive at a site wherein a corrective action can be initiated. This could be a control room, operations center, etc. The

alarming mechanism can be a standard alarming system or an auto-polling system; the only requirement is that the alarm be brought to the action-site within 24 hours. This effectively makes manned-stations equivalent to monitored stations. The alarm of a monitored point (for example a monitored trip path with a lamp) in a manned-station now makes that monitored point eligible for monitored status. Obviously, these same rules apply to a non-manned-station, which is that if the monitored point has an alarm that is auto-reported to the operations center (for example) within 24 hours, then it too is considered monitored.

15.6.1 Frequently Asked Questions:

Why are there activities defined for varying degrees of monitoring a Protection System component when that level of technology may not yet be available?

There may already be some equipment available that is capable of meeting the highest levels of monitoring criteria listed in the Tables. However, even if there is no equipment available today that can meet this level of monitoring the standard establishes the necessary requirements for when such equipment becomes available. By creating a roadmap for development, this provision makes the standard technology neutral. The Standard Drafting Team wants to avoid the need to revise the standard in a few years to accommodate technology advances that may be coming to the industry.

Does a fail-safe "form b" contact that is alarmed to a 24/7 operation center classify as an alarm path with monitoring?

If the fail-safe "form-b" contact that is alarmed to a 24/7 operation center causes the alarm to activate for failure of any portion of the alarming path from the alarm origin to the 24/7 operations center, then this can be classified as an alarm path with monitoring.

15.7 Distributed UFLS and Distributed UVLS Systems (Table 3)

Distributed UFLS and distributed UVLS systems have their maintenance activities documented in Table 3 due to their distributed nature allowing reduced maintenance activities and extended maximum maintenance intervals. Relays have the same maintenance activities and intervals as Table 1-1. Voltage and current-sensing devices have the same maintenance activity and interval as Table 1-3. DC systems need only have their voltage read at the relay every 12 years. Control circuits have the following maintenance activities every 12 years:

- Verify the trip path between the relay and lock-out and/or auxiliary tripping device(s).
- Verify operation of any lock-out and/or auxiliary tripping device(s) used in the trip circuit.
- No verification of trip path required between the lock-out (and/or auxiliary tripping device) and the non-BES interrupting device.
- No verification of trip path required between the relay and trip coil for circuits that have no lock-out and/or auxiliary tripping device(s).
- No verification of trip coil required.

No maintenance activity is required for associated communication systems for distributed UFLS and distributed UVLS schemes.

Non-BES interrupting devices that participate in a distributed UFLS or distributed UVLS scheme are excluded from the tripping requirement, and part of the control circuit test requirement;

however, the part of the trip path control circuitry between the Load-Shed relay and lock-out or auxiliary tripping relay must be tested at least once every 12 years. In the case where there is no lock-out or auxiliary tripping relay used in a distributed UFLS or UVLS scheme which is not part of the BES, there is no control circuit test requirement. There are many circuit interrupting devices in the distribution system that will be operating for any given under-frequency event that requires tripping for that event. A failure in the tripping action of a single distributed system circuit breaker (or non-BES equipment interruption device) will be far less significant than, for example, any single transmission Protection System failure, such as a failure of a bus differential lock-out relay. While many failures of these distributed system circuit breakers (or non-BES equipment interruption device) could add up to be significant, it is also believed that many circuit breakers are operated often on just Fault clearing duty; and, therefore, these circuit breakers are operated at least as frequently as any requirements that appear in this standard.

There are times when a Protection System component will be used on a BES device, as well as a non-BES device, such as a battery bank that serves both a BES circuit breaker and a non-BES interrupting device used for UFLS. In such a case, the battery bank (or other Protection System component) will be subject to the Tables of the standard because it is used for the BES.

15.7.1 Frequently Asked Questions:

The standard reaches further into the distribution system than we would like for UFLS and UVLS

While UFLS and UVLS equipment are located on the distribution network, their job is to protect the Bulk Electric System. This is not beyond the scope of NERC's Section 215 authority.

FPA section 215(a) definitions section defines bulk power system as: "(A) facilities and control Systems necessary for operating an interconnected electric energy transmission network (or any portion thereof)." That definition, then, is limited by a later statement which adds the term bulk power system "...does not include facilities used in the local distribution of electric energy." Also, Section 215 also covers users, owners, and operators of bulk power Facilities.

UFLS and UVLS (when the UVLS is installed to prevent system voltage collapse or voltage instability for BES reliability) are not "used in the local distribution of electric energy," despite their location on local distribution networks. Further, if UFLS/UVLS Facilities were not covered by the reliability standards, then in order to protect the integrity of the BES during under-frequency or under-voltage events, that Load would have to be shed at the Transmission bus to ensure the Load-generation balance and voltage stability is maintained on the BES.

15.8 Automatic Reclosing (Table 4)

Please see the document referenced in Section F of PRC-005-3, "Considerations for Maintenance and Testing of Autoreclosing Schemes — November 2012", for a discussion of Automatic Reclosing as addressed in PRC-005-3.

15.8.1 Frequently-asked Questions

Automatic Reclosing is a control, not a protective function; why then is Automatic Reclosing maintenance included in the Protection System Maintenance Program (PSMP)?

Automatic Reclosing is a control function. The standard's title 'Protection System and Automatic Reclosing Maintenance' clearly distinguishes (separates) the Automatic Reclosing from the Protection System. Automatic Reclosing is included in the PSMP because it is a more pragmatic approach as compared to creating a parallel and essentially identical 'Control System Maintenance Program' for the Automatic Reclosing component types.

When do I need to have the initial maintenance of Automatic Reclosing Components completed upon change of the largest BES generating unit in the BA/RSG?

The maintenance interval, for newly identified Automatic Reclosing Components, starts when a change in the largest BES generating unit is determined by the BA/RSG. The first maintenance records for newly identified Automatic Reclosing Components should be dated no later than the maximum maintenance interval after the identification date. The maximum maintenance intervals for each newly identified Component are defined in Table 4. No activities or records are required prior to the date of identification.

Our maintenance practice consists of initiating the Automatic Reclosing relay and confirming the breaker closes properly and the close signal is released. This practice verifies the control circuitry associated with Automatic Reclosing. Do you agree?"

The described task partially verifies the control circuit maintenance activity. To meet the control circuit maintenance activity, responsible entities need to verify, *upon initiation*, that the reclosing relay does not issue a *premature closing command*. As noted on page 12 of the SAMS/SPCS report, the concern being addressed within the standard is premature auto reclosing that has the potential to cause generating unit or plant instability. Reclosing applications have many variations, responsible entities will need to verify the applicability of associated supervision/conditional logic and the reclosing relay operation; then verify the conditional logic or that the reclosing relay performs in a manner that does not result in a *premature closing command* being issued.

Some examples of conditions which can result in a premature closing command are: an improper supervision or conditional logic input which provides a false state and allows the reclosing relay to issue an improper close command based on incorrect conditions (i.e. voltage supervision, equipment status, sync window verification); timers utilized for closing actuation or reclosing arming/disarming circuitry which could allow the reclosing relay to issue an improper close command; a reclosing relay output contact failure which could result in a made-up-close condition / failure-to-release condition.

Why was a close-in three phase fault present for twice the normal clearing time chosen for the Automatic Reclosing exclusion? It exceeds TPL requirements and ignores the breaker closing time in a trip-close-trip sequence, thus making the exclusion harder to attain.

This condition represents a situation where a close signal is issued with no time delay or with less time delay than is intended, such as if a reclosing contact is welded closed. This failure mode can result in a minimum trip-close-trip sequence with the two faults cleared in primary protection operating time, and the open time between faults equal to the breaker closing cycle time. The sequence for this failure mode results in system impact equivalent to a high-speed

autoreclosing sequence with no delay added in the autoreclosing logic. It represents a failure mode which must be avoided because it exceeds TPL requirements.

Do we have to test the various breaker closing circuit interlocks and controls such as anti-pump?

These components are not specifically addressed within Table 4, and need not be individually tested.

For Automatic Reclosing that is not part of an RAS, do we have to close the circuit breaker periodically?

No--for this application, you need only to verify that the Automatic Reclosing, upon initiation, does not issue a premature closing command. This activity is concerned only with assuring that a premature close does not occur, and cause generating plant instability.

For Automatic Reclosing that is part of an RAS, do we have to close the circuit breaker periodically?

Yes--in this application, successful closing is a necessary portion of the RAS, and must be verified.

Why is maintenance of supervisory relays now included in PRC-005 for Automatic Reclosing?

Proper performance of supervising relays supports the reliability of the BES because some conditions can result in a premature closing command. An example of this would be an improper supervision or conditional logic input which provides a false state and allows the reclosing relay to issue an improper close command based on incorrect conditions (i.e. voltage supervision, sync window verification)

My reclosing circuitry contains the following inputs listed below. Which parts of the control circuitry would need to **be verified, upon initiation, do not issue a premature close command per PRC-005?**

- 79/ON – Supervisory contact which turns Automatic Reclosing ON or OFF
- 52 – Supervisory contact which provides breaker indication (“b” contact)
- 86 - Supervisory contact from a lockout relay
- 79 – Supervisory contact from a reclosing relay
- 25 – Supervisory contact from a sync-check relay
- 27 or 59 – Supervisory contact from an undervoltage or overvoltage relay

Supervisory Relays are defined in this standard as “relay(s) that perform voltage and/or sync check functions that enables or disables operation of the reclosing relay.” The 79, 25, and 27 or 59 would need to be verified because they are supervisory devices that are associated with Automatic Reclosing. The 79/ON, 52, and 86 would not need to be verified.

The sync check and voltage check functions are part of my microprocessor reclosing relay. Are there any test requirements for these internal supervisory functions?

A microprocessor reclosing relay that is using internal sync check or voltage check supervisory functions is a combinational reclosing and supervisory relay (i.e. 79/25).). The maintenance

activities for both a reclosing relay and supervisory relay would apply. The voltage sensing devices providing input to a combinational reclosing and supervisory relay would require the activities in Table 4-3.

Is it necessary to verify the close signal operates the breaker?

Only when the control circuitry associated with automatic reclosing is a part of a RAS, then all paths that are essential for proper operation of the RAS must be verified, per table 4-2(b).

15.9 Sudden Pressure Relaying (Table 5)

Please see the document referenced in Section F of PRC-005-6, “Sudden Pressure Relays and Other Devices that Respond to Non-Electrical Quantities – December 2013”, for a discussion of Sudden Pressure Relaying as addressed in PRC-005-6.

15.9.1 Frequently Asked Questions:

How do I verify the pressure or flow sensing mechanism is operable?

Maintenance activities for the fault pressure relay associated with Sudden Pressure Relaying in PRC-005-6 are intended to verify that the pressure and/or flow sensing mechanism are functioning correctly. Beyond this, PRC-005-6 requires no calibration (adjusting the operating threshold or measurement accuracy of a measuring element to meet the intended performance requirement) or testing (applying signals to a component to observe functional performance or output behavior, or to diagnose problems) activities. For example, some designs of flow sensing mechanisms allow the operation of a test switch to actuate the limit switch of the flow sensing mechanism. Operation of this test switch and verification of the flow sensing mechanism would meet the requirements of the maintenance activity. Another example involves a gas pressure sensing mechanism which is isolated by a test plug. Removal of the plug and verification of the bellows mechanism would meet the requirements of the maintenance activity.

Why the 6-year maximum maintenance interval for fault pressure relays?

The SDT established the six-year maintenance interval for fault pressure relays (see Table 5, PRC-005-6) based on the recommendation of the System Protection and Control Subcommittee (SPCS). The technical experts of the SPCS were tasked with developing the technical documents to:

- i. Describe the devices and functions (to include sudden pressure relays which trip for fault conditions) that should address FERC’s concern; and
- ii. Propose minimum maintenance activities for such devices and maximum maintenance intervals, including the technical basis for each.

Excerpt from the [SPCS technical report](#): “In order to determine present industry practices related to sudden pressure relay maintenance, the SPCS conducted a survey of Transmission Owners and Generator Owners in all eight Regions requesting information related to their maintenance practices. The SPCS received responses from 75 Transmission Owners and 109 Generator Owners. Note that, for the purpose of the survey, sudden pressure relays included the following: the “sudden pressure relay” (SPR) originally manufactured by Westinghouse, the “rapid pressure rise relay” (RPR) manufactured by Qualitrol, and a variety of Buchholz relays.

Table 2 provides a summary of the results of the responses:

Table 2: Sudden Pressure Relay Maintenance Practices – Survey Results		
	Transmission Owner	Generator Owner
Number of responding owners that trip with Sudden Pressure Relays:	67	84
Percentage of responding owners who trip that have a Maintenance Program:	75%	78%
Percentage of maintenance programs that include testing the pressure actuator:	81%	77%
Average Maintenance interval reported:	5.9 years	4.9 years

Additionally, in order to validate the information noted above, the SPCS contacted the following entities for their feedback: the IEEE Power System Relaying Committee, the IEEE Transformer Committee, the Doble Transformer Committee, the NATF System Protection Practices Group, and the EPRI Generator Owner/Operator Technical Focus Group. All of these organizations indicated the results of the SPCS survey are consistent with their respective experiences.

The SPCS discussed the potential difference between the recommended intervals for fault pressure relaying and intervals for transformer maintenance. The SPCS developed the recommended intervals for fault pressure relaying by comparing fault pressure relaying to Protection System Components with similar physical attributes. The SPCS recognized that these intervals may be shorter than some existing or future transformer maintenance intervals, but believed it to be more important to base intervals for fault pressure relaying on similar Protection System Components than transformer maintenance intervals.

The maintenance interval for fault pressure relays can be extended by utilizing performance-based maintenance thereby allowing entities that have maintenance intervals for transformers in excess of six years, to align them.

Sudden Pressure Relaying control circuitry is now specifically mentioned in the maintenance tables. Do we have to trip our circuit breaker specifically from the trip output of the sudden pressure relay?

No--verification may be by breaker tripping, but may be verified in overlapping segments with the Protection System control circuitry.

Can we use Performance Based Maintenance for fault pressure relays?

Yes--performance Based Maintenance is applicable to fault pressure relays.

15.10 Examples of Evidence of Compliance

To comply with the requirements of this standard, an entity will have to document and save evidence. The evidence can be of many different forms. The Standard Drafting Team recognizes

that there are concurrent evidence requirements of other NERC standards that could, at times, fulfill evidence requirements of this standard.

15.10.1 Frequently Asked Questions:

What forms of evidence are acceptable?

Acceptable forms of evidence, as relevant for the requirement being documented include, but are not limited to:

- Process documents or plans
- Data (such as relay settings sheets, photos, SCADA, and test records)
- Database lists, records and/or screen shots that demonstrate compliance information
- Prints, diagrams and/or schematics
- Maintenance records
- Logs (operator, substation, and other types of log)
- Inspection forms
- Mail, memos, or email proving the required information was exchanged, coordinated, submitted or received
- Check-off forms (paper or electronic)
- Any record that demonstrates that the maintenance activity was known, accounted for, and/or performed.

If I replace a failed Protection System component with another component, what testing do I need to perform on the new component?

In order to reset the Table 1 maintenance interval for the replacement component, all relevant Table 1 activities for the component should be performed.

I have evidence to show compliance for PRC-016 ("Special Protection System Misoperation"). Can I also use it to show compliance for this Standard, PRC-005-6?

Maintaining evidence for operation of Remedial Action Schemes could concurrently be utilized as proof of the operation of the associated trip coil (provided one can be certain of the trip coil involved). Thus, the reporting requirements that one may have to do for the Misoperation of a Special Protection Scheme under PRC-016 could work for the activity tracking requirements under this PRC-005-6.

I maintain Disturbance records which show Protection System operations. Can I use these records to show compliance?

These records can be concurrently utilized as dc trip path verifications, to the degree that they demonstrate the proper function of that dc trip path.

I maintain test reports on some of my Protection System components. Can I use these test reports to show that I have verified a maintenance activity?

Yes—the test reports may be used to demonstrate a verified maintenance activity.

References

1. [Protection System Maintenance: A Technical Reference](#). Prepared by the System Protection and Controls Task Force of the NERC Planning Committee. Dated September 13, 2007.
2. "Predicating The Optimum Routine test Interval For Protection Relays," by J. J. Kumm, M.S. Weber, D. Hou, and E. O. Schweitzer, III, IEEE Transactions on Power Delivery, Vol. 10, No. 2, April 1995.
3. "Transmission Relay System Performance Comparison For 2000, 2001, 2002, 2003, 2004 and 2005," Working Group I17 of Power System Relaying Committee of IEEE Power Engineering Society, May 2006.
4. "A Survey of Relaying Test Practices," Special Report by WG I11 of Power System Relaying Committee of IEEE Power Engineering Society, September 16, 1999.
5. "Transmission Protective Relay System Performance Measuring Methodology," Working Group I3 of Power System Relaying Committee of IEEE Power Engineering Society, January 2002.
6. "Processes, Issues, Trends and Quality Control of Relay Settings," Working Group C3 of Power System Relaying Committee of IEEE Power Engineering Society, December 2006.
7. "Proposed Statistical Performance Measures for Microprocessor-Based Transmission-Line Protective Relays, Part I - Explanation of the Statistics, and Part II - Collection and Uses of Data," Working Group D5 of Power System Relaying Committee of IEEE Power Engineering Society, May 1995; Papers 96WM 016-6 PWRD and 96WM 127-1 PWRD, 1996 IEEE Power Engineering Society Winter Meeting.
8. "Analysis And Guidelines For Testing Numerical Protection Schemes," Final Report of CIGRE WG 34.10, August 2000.
9. "Use of Preventative Maintenance and System Performance Data to Optimize Scheduled Maintenance Intervals," H. Anderson, R. Loughlin, and J. Zipp, Georgia Tech Protective Relay Conference, May 1996.
10. "Battery Performance Monitoring by Internal Ohmic Measurements" EPRI Application Guidelines for Stationary Batteries TR- 108826 Final Report, December 1997.
11. "IEEE Recommended Practice for Maintenance, Testing, and Replacement of Valve-Regulated Lead-Acid (VRLA) Batteries for Stationary Applications," IEEE Power Engineering Society Std 1188 – 2005.
12. "IEEE Recommended Practice for Maintenance, Testing, and Replacement of Vented Lead-Acid Batteries for Stationary Applications," IEEE Power & Engineering Society Std 45-2010.
13. "IEEE Recommended Practice for Installation design and Installation of Vented Lead-Acid Batteries for Stationary Applications," IEEE Std 484 – 2002.
14. "Stationary Battery Monitoring by Internal Ohmic Measurements," EPRI Technical Report, 1002925 Final Report, December 2002.
15. "Stationary Battery Guide: Design Application, and Maintenance" EPRI Revision 2 of TR-100248, 1006757, August 2002.

PSMT SDT References

16. "Essentials of Statistics for Business and Economics" Anderson, Sweeney, Williams, 2003
17. "Introduction to Statistics and Data Analysis" - Second Edition, Peck, Olson, Devore, 2005
18. "Statistical Analysis for Business Decisions" Peters, Summers, 1968
19. "Considerations for Maintenance and Testing of Autoreclosing Schemes," NERC System Analysis and Modeling Subcommittee and NERC System Protection and Control Subcommittee, November 2012

Figures

Figure 1: Typical Transmission System

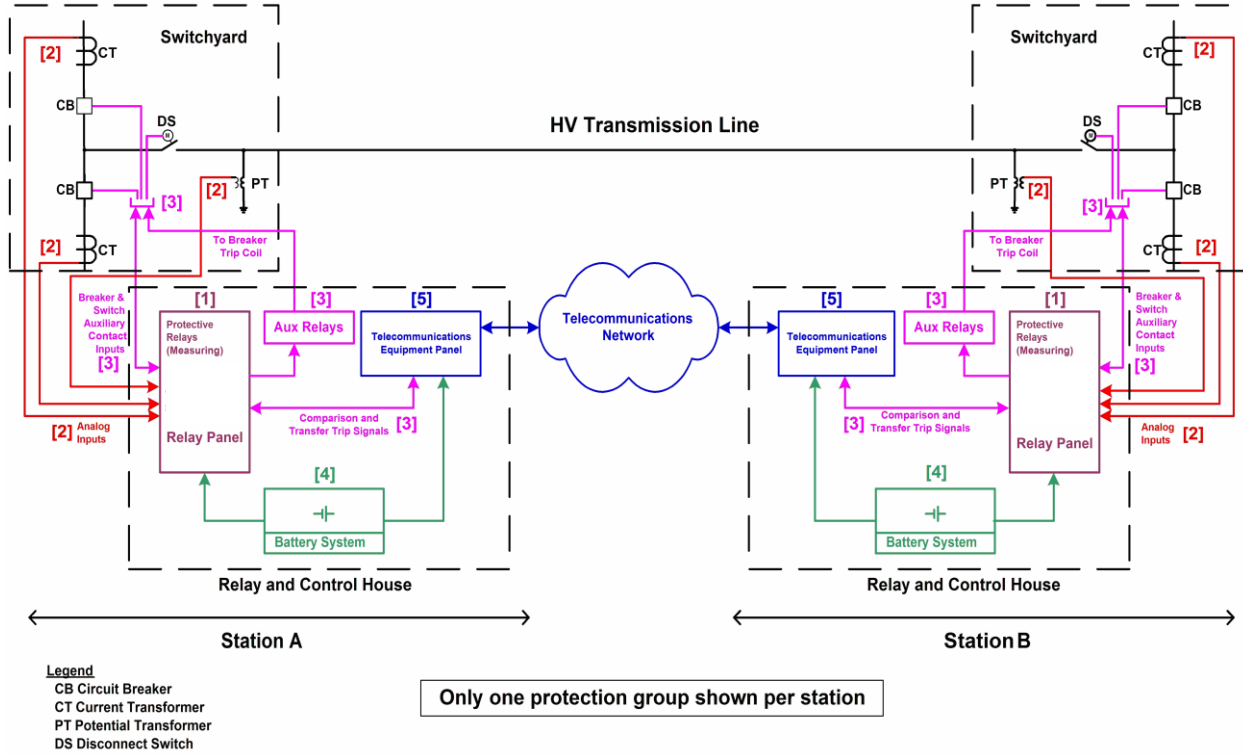

For information on components, see [Figure 1 & 2 Legend – components of Protection Systems](#)

Figure 2: Typical Generation System

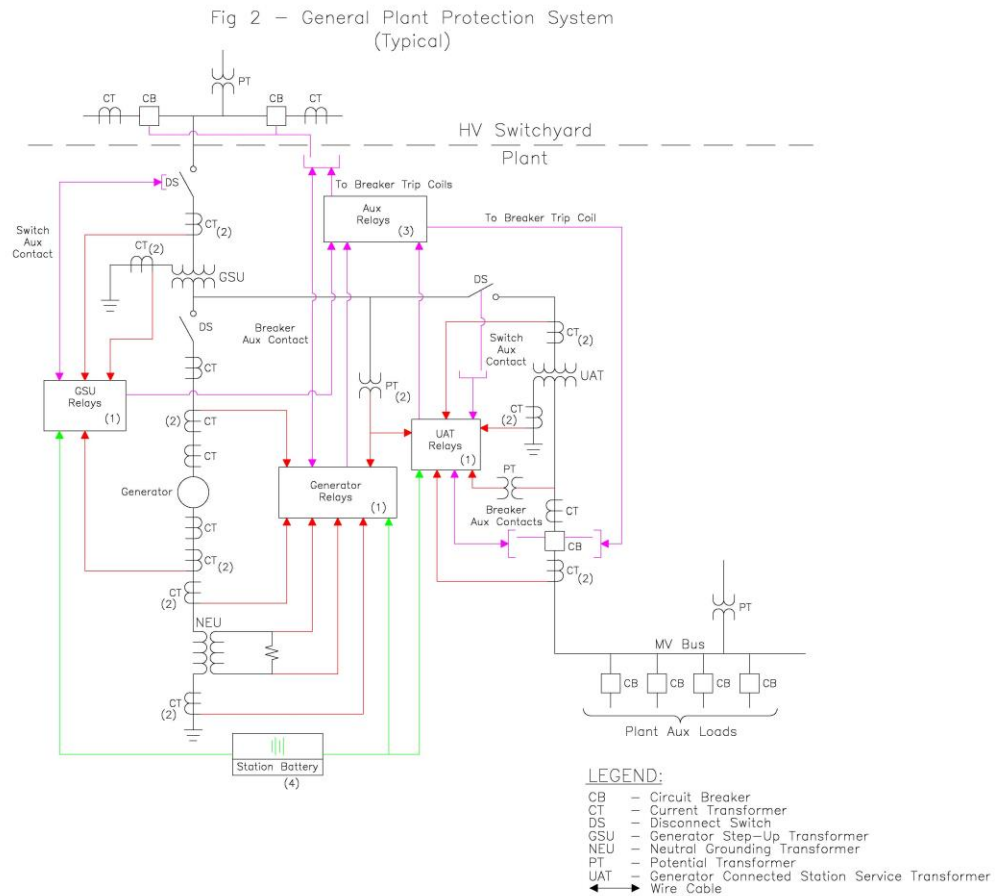

Note: Figure 2 may show elements that are not included within PRC-005-2, and also may not be all-inclusive; see the Applicability section of the standard for specifics.

For information on components, see [Figure 1 & 2 Legend – components of Protection Systems](#)

Figure 1 & 2 Legend – Components of Protection Systems

Number in Figure	Component of Protection System	Includes	Excludes
1	Protective relays which respond to electrical quantities	All protective relays that use current and/or voltage inputs from current & voltage sensors and that trip the 86, 94 or trip coil.	Devices that use non-electrical methods of operation including thermal, pressure, gas accumulation, and vibration. Any ancillary equipment not specified in the definition of Protection Systems. Control and/or monitoring equipment that is not a part of the automatic tripping action of the Protection System
2	Voltage and current sensing devices providing inputs to protective relays	The signals from the voltage & current sensing devices to the protective relay input.	Voltage & current sensing devices that are not a part of the Protection System, including sync-check systems, metering systems and data acquisition systems.
3	Control circuitry associated with protective functions	All control wiring (or other medium for conveying trip signals) associated with the tripping action of 86 devices, 94 devices or trip coils (from all parallel trip paths). This would include fiber-optic systems that carry a trip signal as well as hard-wired systems that carry trip current.	Closing circuits, SCADA circuits, other devices in control scheme not passing trip current
4	Station dc supply	Batteries and battery chargers and any control power system which has the function of supplying power to the protective relays, associated trip circuits and trip coils.	Any power supplies that are not used to power protective relays or their associated trip circuits and trip coils.
5	Communications systems necessary for correct operation of protective functions	Tele-protection equipment used to convey specific information, in the form of analog or digital signals, necessary for the correct operation of protective functions.	Any communications equipment that is not used to convey information necessary for the correct operation of protective functions.

[Additional information can be found in References](#)

Appendix A

The following illustrates the concept of overlapping verifications and tests as summarized in Section 10 of the paper. As an example, Figure A-1 shows protection for a critical transmission line by carrier blocking directional comparison pilot relaying. The goal is to verify the ability of the entire two-terminal pilot protection scheme to protect for line faults, and to avoid over-tripping for faults external to the transmission line zone of protection bounded by the current transformer locations.

Figure A-1

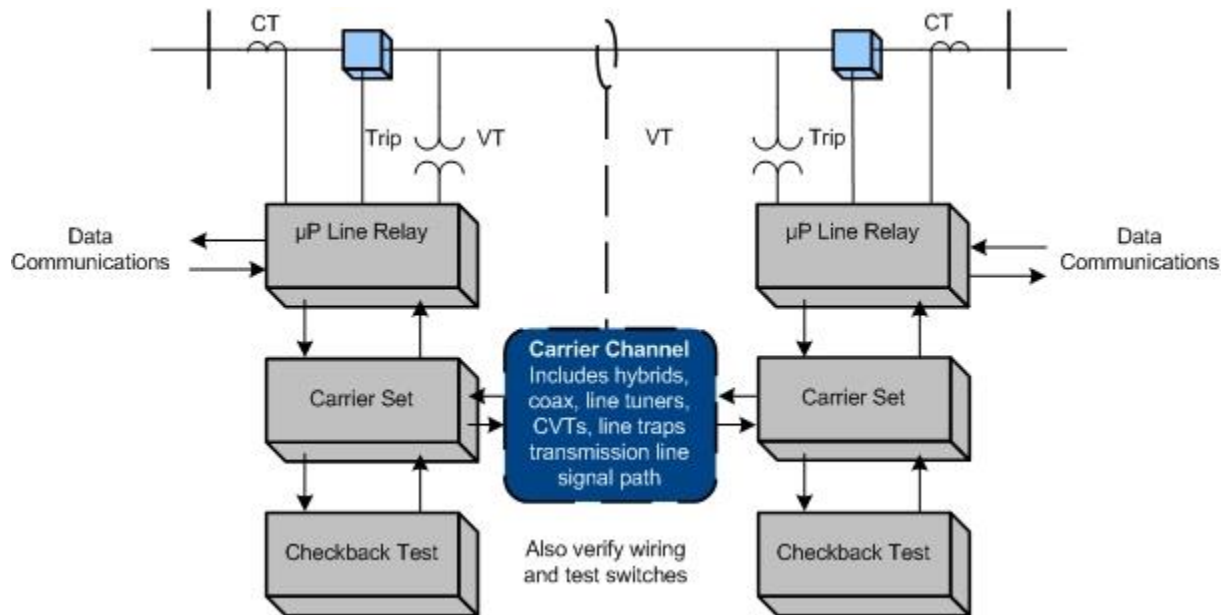

In this example (Figure A1), verification takes advantage of the self-monitoring features of microprocessor multifunction line relays at each end of the line. For each of the line relays themselves, the example assumes that the user has the following arrangements in place:

1. The relay has a data communications port that can be accessed from remote locations.
2. The relay has internal self-monitoring programs and functions that report failures of internal electronics, via communications messages or alarm contacts to SCADA.
3. The relays report loss of dc power, and the relays themselves or external monitors report the state of the dc battery supply.
4. The CT and PT inputs to the relays are used for continuous calculation of metered values of volts, amperes, plus Watts and vars on the line. These metered values are reported by data communications. For maintenance, the user elects to compare these readings to those of other relays, meters, or DFRs. The other readings may be from redundant relaying or measurement systems or they may be derived from values in other protection zones. Comparison with other such readings to within required relaying accuracy verifies voltage and current sensing devices, wiring, and analog signal input processing of the relays. One

effective way to do this is to utilize the relay metered values directly in SCADA, where they can be compared with other references or state estimator values.

5. Breaker status indication from auxiliary contacts is verified in the same way as in (2). Status indications must be consistent with the flow or absence of current.
6. Continuity of the breaker trip circuit from dc bus through the trip coil is monitored by the relay and reported via communications.
7. Correct operation of the on-off carrier channel is also critical to security of the Protection System, so each carrier set has a connected or integrated automatic checkback test unit. The automatic checkback test runs several times a day. Newer carrier sets with integrated checkback testing check for received signal level and report abnormal channel attenuation or noise, even if the problem is not severe enough to completely disable the channel.

These monitoring activities plus the check-back test comprise automatic verification of all the Protection System elements that experience tells us are the most prone to fail. But, does this comprise a complete verification?

Figure A-2

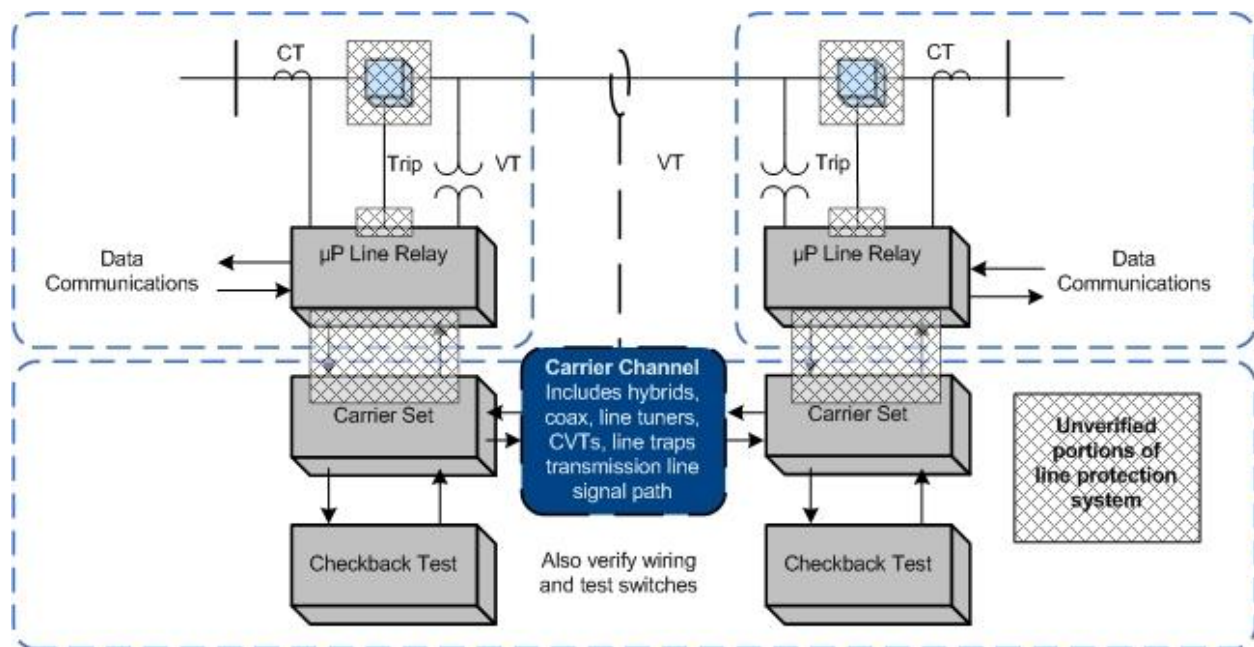

The dotted boxes of Figure A-2 show the sections of verification defined by the monitoring and verification practices just listed. These sections are not completely overlapping, and the shaded regions show elements that are not verified:

1. The continuity of trip coils is verified, but no means is provided for validating the ability of the circuit breaker to trip if the trip coil should be energized.

-
2. Within each line relay, all the microprocessors that participate in the trip decision have been verified by internal monitoring. However, the trip circuit is actually energized by the contacts of a small telephone-type "ice cube" relay within the line protective relay. The microprocessor energizes the coil of this ice cube relay through its output data port and a transistor driver circuit. There is no monitoring of the output port, driver circuit, ice cube relay, or contacts of that relay. These components are critical for tripping the circuit breaker for a Fault.
 3. The check-back test of the carrier channel does not verify the connections between the relaying microprocessor internal decision programs and the carrier transmitter keying circuit or the carrier receiver output state. These connections include microprocessor I/O ports, electronic driver circuits, wiring, and sometimes telephone-type auxiliary relays.
 4. The correct states of breaker and disconnect switch auxiliary contacts are monitored, but this does not confirm that the state change indication is correct when the breaker or switch opens.

A practical solution for (1) and (2) is to observe actual breaker tripping, with a specified maximum time interval between trip tests. Clearing of naturally-occurring Faults are demonstrations of operation that reset the time interval clock for testing of each breaker tripped in this way. If Faults do not occur, manual tripping of the breaker through the relay trip output via data communications to the relay microprocessor meets the requirement for periodic testing.

PRC-005-6 does not address breaker maintenance, and its Protection System test requirements can be met by energizing the trip circuit in a test mode (breaker disconnected) through the relay microprocessor. This can be done via a front-panel button command to the relay logic, or application of a simulated Fault with a relay test set. However, utilities have found that breakers often show problems during Protection System tests. It is recommended that Protection System verification include periodic testing of the actual tripping of connected circuit breakers.

Testing of the relay-carrier set interface in (3) requires that each relay key its transmitter, and that the other relay demonstrate reception of that blocking carrier. This can be observed from relay or DFR records during naturally occurring Faults, or by a manual test. If the checkback test sequence were incorporated in the relay logic, the carrier sets and carrier channel are then included in the overlapping segments monitored by the two relays, and the monitoring gap is completely eliminated.

Appendix B

Protection System Maintenance Standard Drafting Team

Charles W. Rogers
Chairman
Consumers Energy Co.

John B. Anderson
Xcel Energy

Stephen Crutchfield
NERC

Forrest Brock
Western Farmers Electric Cooperative

John Schechter
American Electric Power

Aaron Feathers
Pacific Gas and Electric Company

William D. Shultz
Southern Company Generation

Sam Francis
Oncor Electric Delivery

James M. Kinney
FirstEnergy Corporation

Scott Vaughan
City of Roseville Electric Department
Matthew Westrich
American Transmission Company

Kristina Marriott
ENOSERV

Philip B. Winston
Southern Company Transmission

NERC

NORTH AMERICAN ELECTRIC
RELIABILITY CORPORATION

Supplementary Reference and FAQ

PRC-005-~~4-6~~ Protection System, Automatic
Reclosing, and Sudden Pressure Relaying
Maintenance and Testing

July 2015~~October 2014~~

RELIABILITY | ACCOUNTABILITY



3353 Peachtree Road NE
Suite 600, North Tower
Atlanta, GA 30326
404-446-2560 | www.nerc.com

Table of Contents

Table of Contents.....	ii
1. Introduction and Summary.....	1
2. Need for Verifying Protection System Performance	2
2.1 Existing NERC Standards for Protection System Maintenance and Testing	2
2.2 Protection System Definition	3
2.3 Applicability of New Protection System Maintenance Standards	3
2.3.1 Frequently Asked Questions:	4
2.4.1 Frequently Asked Questions:	6
3. Protection System and Automatic Reclosing Product Generations	159
4. Definitions.....	1741
4.1 Frequently Asked Questions:	1812
5. Time-Based Maintenance (TBM) Programs.....	2014
5.1 Maintenance Practices.....	2014
5.1.1 Frequently Asked Questions:	2216
5.2 Extending Time-Based Maintenance	2517
5.2.1 Frequently Asked Questions:	2618
6. Condition-Based Maintenance (CBM) Programs.....	2719
6.1 Frequently Asked Questions:	2719
7. Time-Based Versus Condition-Based Maintenance.....	2921
7.1 Frequently Asked Questions:	2921
8. Maximum Allowable Verification Intervals	3527
8.1 Maintenance Tests.....	3527
8.1.1 Table of Maximum Allowable Verification Intervals.....	3527

8.1.2 Additional Notes for Tables 1-1 through 1-5, Table 3, and Table 4.....	<u>3729</u>
8.1.3 Frequently Asked Questions:	<u>3830</u>
8.2 Retention of Records.....	<u>4335</u>
8.2.1 Frequently Asked Questions:	<u>4435</u>
8.3 Basis for Table 1 Intervals	<u>4637</u>
8.4 Basis for Extended Maintenance Intervals for Microprocessor Relays	<u>4738</u>
9. Performance-Based Maintenance Process.....	<u>5041</u>
9.1 Minimum Sample Size	<u>5142</u>
9.2 Frequently Asked Questions:	<u>5444</u>
10. Overlapping the Verification of Sections of the Protection System	<u>6655</u>
10.1 Frequently Asked Questions:	<u>6655</u>
11. Monitoring by Analysis of Fault Records	<u>6756</u>
11.1 Frequently Asked Questions:	<u>6857</u>
12. Importance of Relay Settings in Maintenance Programs	<u>6958</u>
12.1 Frequently Asked Questions:	<u>6958</u>
13. Self-Monitoring Capabilities and Limitations	<u>7261</u>
13.1 Frequently Asked Questions:	<u>7362</u>
14. Notification of Protection System or Automatic Reclosing Failures	<u>7463</u>
15. Maintenance Activities	<u>7564</u>
15.1 Protective Relays (Table 1-1)	<u>7564</u>
15.1.1 Frequently Asked Questions:	<u>7564</u>
15.2 Voltage & Current Sensing Devices (Table 1-3)	<u>7564</u>
15.2.1 Frequently Asked Questions:	<u>7766</u>
15.3 Control circuitry associated with protective functions (Table 1-5)	<u>7867</u>
15.3.1 Frequently Asked Questions:	<u>7969</u>

15.4 Batteries and DC Supplies (Table 1-4).....	<u>8174</u>
15.4.1 Frequently Asked Questions:	<u>8274</u>
15.5 Associated communications equipment (Table 1-2)	<u>9686</u>
15.5.1 Frequently Asked Questions:	<u>9887</u>
15.6 Alarms (Table 2)	<u>10190</u>
15.6.1 Frequently Asked Questions:	<u>10190</u>
15.7 Distributed UFLS and Distributed UVLS Systems (Table 3)	<u>10294</u>
15.7.1 Frequently Asked Questions:	<u>10394</u>
15.8 Automatic Reclosing (Table 4)	<u>10392</u>
15.8.1 Frequently-asked Questions	<u>10392</u>
15.9 Examples of Evidence of Compliance	<u>10694</u>
15.9.1 Frequently Asked Questions:	<u>10894</u>
References	<u>10995</u>
Figures.....	<u>11197</u>
Figure 1: Typical Transmission System.....	<u>11197</u>
Figure 2: Typical Generation System	<u>11298</u>
Figure 1 & 2 Legend – Components of Protection Systems	<u>11399</u>
Appendix A.....	<u>114100</u>
Appendix B	<u>118403</u>
Protection System Maintenance Standard Drafting Team.....	<u>118403</u>

1. Introduction and Summary

Note: This supplementary reference for PRC-005-~~4-6~~ is neither mandatory nor enforceable.

NERC currently has four Reliability Standards that are mandatory and enforceable ~~within~~ the ~~jurisdiction of the ERO United States and Canada~~ and address various aspects of maintenance and testing of Protection and Control Systems.

These standards are:

PRC-005-1b — Transmission and Generation Protection System Maintenance and Testing

PRC-008-0 — Underfrequency Load Shedding Equipment Maintenance Programs

PRC-011-0 — UVLS System Maintenance and Testing

PRC-017-0 — Special Protection System Maintenance and Testing

While these standards require that applicable entities have a maintenance program for Protection Systems, and that these entities must be able to demonstrate they are carrying out such a program, there are no specifics regarding the technical requirements for Protection System maintenance programs. Furthermore, FERC Order 693 directed additional modifications ~~to the~~ respective ~~to~~ Protection System maintenance programs. PRC-005-3 will replace PRC-005-2 which combined and replaced PRC-005, PRC-008, PRC-011 and PRC-017. PRC-005-3 adds Automatic Reclosing to PRC-005-2. PRC-005-2 addressed these directed modifications and replaces PRC-005, PRC-008, PRC-011 and PRC-017.

FERC Order 758 further directed that maintenance of reclosing relays and sudden pressure relays that affect the reliable operation of the Bulk Power System be addressed. PRC-005-3 addresses this directive regarding reclosing relays, and, when approved, will supersede PRC-005-2. PRC-005-4 addresses this directive regarding sudden pressure relays and, when approved, will supersede PRC-005-3.

This document augments the Supplementary Reference and FAQ previously developed for PRC-005-2 by including discussion relevant to Automatic Reclosing added in PRC-005-3 and Sudden Pressure Relaying in PRC-005-4.

2. Need for Verifying Protection System Performance

Protective relays have been described as silent sentinels, and do not generally demonstrate their performance until a Fault or other power system problem requires that they operate to protect power system Elements, or even the entire Bulk Electric System (BES). Lacking Faults, switching operations or system problems, the Protection Systems may not operate, beyond static operation, for extended periods. A Misoperation—defined as—a false operation of a Protection System or a failure of the Protection System to operate, as designed, when needed—can result in equipment damage, personnel hazards, and wide-area Disturbances or unnecessary customer outages. Maintenance or testing programs are used to determine the performance and availability of Protection Systems.

Typically, utilities have tested Protection Systems at fixed time intervals, unless they had some incidental evidence that a particular Protection System was not behaving as expected. Testing practices vary widely across the industry. Testing has included system functionality, calibration of measuring devices, and correctness of settings. Typically, a Protection System must be visited at its installation site and, in many cases, removed from service for this testing.

Fundamentally, a Reliability Standard for Protection System Maintenance and Testing requires the performance of the maintenance activities that are necessary to detect and correct plausible age and service related degradation of the Protection System components, such that a properly built and commissioned Protection System will continue to function as designed over its service life.

Similarly station batteries, which are an important part of the station dc supply, are not called upon to provide instantaneous dc power to the Protection System until power is required by the Protection System to operate circuit breakers or interrupting devices to clear Faults or to isolate equipment.

2.1 Existing NERC Standards for Protection System Maintenance and Testing

For critical BES protection functions, NERC standards have required that each utility or asset owner define a testing program. The starting point is the existing Standard PRC-005-5, briefly restated as follows:

Purpose: To document and implement programs for the maintenance of all Protection Systems affecting the reliability of the Bulk Electric System (BES) so that these Protection Systems are kept in working order.

PRC-005-64 is not specific on where the boundaries of the Protection Systems lie. However, the definition of Protection System in the [NERC Glossary of Terms](#) Used in [NERC Reliability Standards \(Glossary\)](#) indicates what must be included as a minimum.

At the beginning of the project to develop PRC-005-2, the definition of Protection System was:

Protective relays, associated communications Systems, voltage and current sensing devices, station batteries and dc control circuitry.

Applicability: Owners of generation and transmission Protection Systems.

Requirements: The owner shall have a documented maintenance program with test intervals. The owner must keep records showing that the maintenance was performed at the specified intervals.

2.2 Protection System Definition

The most recently approved definition of Protection Systems is:

- Protective relays which respond to electrical quantities,
- Communications systems necessary for correct operation of protective functions,
- Voltage and current sensing devices providing inputs to protective relays,
- Station dc supply associated with protective functions (including station batteries, battery chargers, and non-battery-based dc supply), and
- Control circuitry associated with protective functions through the trip coil(s) of the circuit breakers or other interrupting devices.

2.3 Applicability of New Protection System Maintenance Standards

The BES purpose is to transfer bulk power. The applicability language has been changed from the original PRC-005:

“...affecting the reliability of the Bulk Electric System (BES)...”

To the present language:

“...that are installed for the purpose of detecting Faults on BES Elements (lines, buses, transformers, etc.).”

The drafting team intends that this standard will ~~follow~~ be consistent ~~follow~~ with any future definition of the Bulk Electric System. There should be no ambiguity; if the Element is a BES Element, then the Protection System protecting that Element should then be included within this standard. If there is regional variation to the definition, then there will be a corresponding regional variation to the Protection Systems that fall under this standard.

There is no way for the Standard Drafting Team to know whether a specific 230KV line, 115KV line (even 69KV line), for example, should be included or excluded. Therefore, the team ~~set~~ expressed the clear intent that the standard language should simply be applicable to Protection Systems for BES Elements.

The BES is a NERC defined term that, from time to time, may undergo revisions. Additionally, there may ~~even~~ be regional variations that are allowed in the present and future definitions.¹ ~~See the NERC Glossary of Terms Used in Reliability Standards for the present, in-force definition. See Refer to~~ the applicable Regional Reliability Organization for any applicable allowed variations.

While this standard ~~will~~ may undergo revisions in the future, this standard will not attempt to keep up with revisions to the NERC definition of BES, but, rather, simply make BES Protection Systems applicable.

¹ See the NERC Glossary of Terms for the present, in-force definition.

The Standard is applied to Generator Owners (GO) and Transmission Owners (TO) because GOs and TOs have ~~equipment that is~~ BES equipment. The standard brings in Distribution Providers (DP) because, depending on the station configuration of a particular substation, there may be Protection System equipment installed at a non-transmission voltage level (Distribution Provider equipment) that is wholly or partially installed to protect the BES. PRC-005-4 would apply to this equipment. An example is underfrequency load-shedding, which is frequently applied ~~well down into the in~~ distribution ~~systems~~ system to meet PRC-007-0.

PRC-005-2 replaced the existing PRC-005, PRC-008, PRC-011 and PRC-017. Much of the original ~~intent language~~ of those standards was carried forward whenever it was possible to continue the intent ~~without a disagreement and avoid a conflict~~ with FERC Order 693. For example, the original PRC-008 was constructed quite differently than the original PRC-005. The drafting team agrees with the intent of this and notes that distributed tripping schemes would have to exhibit multiple failures to trip before they would prove to be significant, as opposed to a single failure to trip of, for example, a transmission Protection System Bus Differential lock-out relay. While ~~many a~~ substantial number of failures of these distribution breakers could ~~add up to~~ be significant, ~~it is also believed~~ the team concluded likely that distribution breakers are operated often ~~only for an~~ just Fault clearing duty; and, therefore, the distribution circuit breakers are operated at least as frequently as stipulated in any requirement in this standard.

Additionally, since PRC-005-2 replaced PRC-011, it will be important to ~~make the distinction~~ distinguish between under-voltage Protection Systems that protect individual Loads and Protection Systems that are Undervoltage Load Shedding (UVLS) schemes that protect the BES. Any UVLS scheme that had been applicable under PRC-011 is now applicable under PRC-005-2. An example of an under-voltage load-shedding scheme that is not applicable to this standard is one in which the tripping action was intended to prevent low distribution voltage to a specific Load from a Transmission system that was intact except for the line that was out of service, as opposed to preventing a Cascading outage or Transmission system collapse.

It had been correctly noted that the devices needed for PRC-011 are the very same types of devices needed in PRC-005.

Thus, a standard written for Protection Systems of the BES can easily make the needed requirements for Protection Systems, and replace some other standards at the same time.

2.3.1 Frequently Asked Questions:

What exactly is the BES, or Bulk Electric System?

BES is the abbreviation for the defined term Bulk Electric System. BES is a term in the Glossary of Terms used in Reliability Standards, and is not being modified within this draft standard.

Why is Distribution Provider included within the Applicable Entities and as a responsible entity within several of the requirements? Wouldn't anyone having relevant Facilities be a Transmission Owner?

Depending on the station configuration of a particular substation, there may be Protection System equipment installed at a non-transmission voltage level (Distribution Provider equipment) that is wholly or partially installed to protect the BES. PRC-005-4 applies to this equipment. An example is underfrequency load-shedding, which is frequently applied well down into the distribution system to meet [the requirements of](#) PRC-007-0.

We have an under voltage load-shedding (UVLS) system in place that prevents one of our distribution substations from supplying extremely low voltage in the case of a specific transmission line outage. The transmission line is part of the BES. Does this mean that our UVLS system falls within this standard?

The situation, as stated, indicates that the tripping action was intended to prevent low distribution voltage to a specific Load from a Transmission System that was intact, except for the line that was out of service, as opposed to preventing Cascading outage or Transmission System Collapse. This standard is not applicable to this UVLS.

We have a UFLS or UVLS scheme that sheds the necessary Load through distribution-side circuit breakers and circuit reclosers. Do the trip-test requirements for circuit breakers apply to our situation?

No. ~~---~~ Distributed tripping schemes would have to exhibit multiple failures to trip before they would prove to be significant, as opposed to a single failure to trip of, for example, a transmission Protection System bus differential lock-out relay. While many failures of these distribution breakers could add up to be significant, it is also believed that distribution breakers are operated often on just Fault clearing duty; and, therefore, the distribution circuit breakers are operated at least as frequently as any requirements that might have appeared in this standard.

We have a UFLS scheme that, in some locales, sheds the necessary Load through non-BES circuit breakers and, occasionally, even circuit switchers. Do the trip-test requirements for circuit breakers apply to our situation?

If your “non-BES circuit breaker” has been brought into this standard by the inclusion of UFLS requirements, and otherwise would not have been brought into this standard, then the answer is that there are no trip-test requirements. For these devices that are otherwise non-BES assets, these tripping schemes would have to exhibit multiple failures to trip before they would prove to be as significant as, for example, a single failure to trip of a transmission Protection System bus differential lock-out relay.

How does the "Facilities" section of "Applicability" track with the standards that will be retired once PRC-005-2 becomes effective?

In establishing PRC-005-2, the drafting team combined legacy standards PRC-005-1b, PRC-008-0, PRC-011-0, and PRC-017-0. The merger of the subject matter of these standards is reflected in Applicability 4.2.

The intent of the drafting team is that the legacy standards be reflected in PRC-005-2 as follows:

- Applicability of PRC-005-1b for Protection Systems relating to non-generator elements of the BES is addressed in 4.2.1;
- Applicability of PRC-008-0 for underfrequency load shedding systems is addressed in 4.2.2;
- Applicability of PRC-011-0 for undervoltage load shedding relays is addressed in 4.2.3;
- Applicability of PRC-017-0 for Remedial Action Schemes is addressed in 4.2.4;
- Applicability of PRC-005-1b for Protection Systems for BES generators is addressed in 4.2.5 [and 4.2.6](#).

2.4 Applicable Relays

The ~~NERC~~ Glossary definition has a Protection System including relays, dc supply, current and voltage sensing devices, dc control circuitry and associated communications circuits. The relays to which this standard applies are those protective relays that respond to electrical quantities and provide a trip output to trip coils, dc control circuitry or associated communications equipment. This definition extends to IEEE Device No. 86 (lockout relay) and IEEE Device No. 94 (tripping or trip-free relay), as these devices are tripping relays that respond to the trip signal of the protective relay that processed the signals from the current and voltage-sensing devices.

Relays that respond to non-electrical inputs or impulses (such as, but not limited to, vibration, seismic, thermal or gas accumulation) are not included.

Automatic Reclosing is addressed in PRC-005-3 by explicitly addressing them outside the definition of Protection System. The specific locations for applicable Automatic Reclosing are addressed in Applicability Section 4.2.~~67~~.

Sudden Pressure Relaying is addressed in PRC-005-4 by explicitly addressing them outside the definition of Protection System. The specific locations for applicable Sudden Pressure Relaying are addressed in Applicability Section 4.2.1, 4.2.5.2~~7~~, 4.2.5.3, [and 4.2.6](#), ~~and 4.2.5.4~~.

2.4.1 Frequently Asked Questions:

Are power circuit reclosers, reclosing relays, closing circuits and auto-restoration schemes covered in this Standard?

Yes. Automatic Reclosing includes reclosing relays and the associated dc control circuitry. Section 4.2.~~76~~ of the Applicability specifically limits the applicable reclosing relays to:

4.2.~~76~~ Automatic Reclosing

4.2.~~76~~.1 Automatic Reclosing applied on the terminals of Elements connected to the BES bus located at generating plant substations where the total installed gross generating plant capacity is greater than the gross capacity of the largest BES generating unit within the Balancing Authority Area or, if a member of a Reserve Sharing Group, the largest generating unit within the Reserve Sharing Group.

4.2.~~76~~.2 Automatic Reclosing applied on the terminals of all BES Elements at substations one bus away from generating plants specified in Section 4.2.~~7776~~.1

when the substation is less than 10 circuit-miles from the generating plant substation.

4.2.76.3 Automatic Reclosing applied as an integral part of an RAS specified in Section 4.2.4.

Further, Footnote 1 to Applicability Section 4.2.76 establishes that Automatic Reclosing addressed in 4.2.76.1 and 4.2.76.2 may be excluded if the equipment owner can demonstrate that a close-in three-phase fault present for twice the normal clearing time (capturing a minimum trip-close-trip time delay) does not result in a total loss of gross generation in the Interconnection exceeding the gross capacity of the largest relevant BES generating unit where the Automatic Reclosing is applied.

Additionally, Footnote 2 to Applicability Section 4.2.76.1 advises that the entity's PSMP needs to remain current regarding the applicability of Automatic Reclosing Components relative to the largest generating unit within the Balancing Authority Area or Reserve Sharing Group.

The Applicability as detailed above was recommended by the NERC System Analysis and Modeling Subcommittee (SAMS) after a lengthy review of the use of reclosing within the BES. SAMS concluded that automatic reclosing is largely implemented throughout the BES as an operating convenience, and that automatic reclosing mal-performance affects BES reliability only when the reclosing is part of a Remedial Action Schemes, or when premature autoreclosing has the potential to cause generating unit or plant instability. A technical report, "Considerations for Maintenance and Testing of Autoreclosing Schemes — November 2012" is referenced in PRC-005-3 and provides a more detailed discussion of these concerns.

Why did the standard drafting team not include IEEE device numbers to describe Automatic Reclosing Relays?

The drafting team elected not to include IEEE device numbers to describe Automatic Reclosing because Automatic Reclosing component type could be a stand-alone electromechanical relay; or could be the 79 function within a microprocessor based multi-function relay.

~~What is synchronizing or synchronism (Sync-Check (25)) – check relay (Sync-Check - 25)?~~

~~A synchronizing device that produces an output that supervises causes-closure of a circuit breaker between two circuits whose voltages are within prescribed limits of magnitude and within the prescribed, phase angle. It may or may not include voltage or speed control. A sync-check relay permits the paralleling of two circuits that are within prescribed (usually wider) limits of voltage magnitude and, phase angle.~~

~~Is a sync-check (25) relay included in the Automatic Reclosing Control Circuitry?~~

~~Where sync-check relays are included in an Automatic Reclosing scheme that is part of an RAS, the sync-check would be included in the control circuitry (Table 4-2(ab)).~~

~~Where sync-check relays are included in an Automatic Reclosing scheme that is not part of an RAS, the sync-check would not be included in the control circuitry (Table 4-2(a)).~~

~~The SDT asserts that a sync check (25) relay does not initiate closing but rather enables or disables closing and is not considered a part of the actual Automatic Reclosing control circuitry when not part of an RAS.~~

How do I interpret Applicability Section 4.2.76 to determine applicability in the following examples:

At my generating plant substation, I have a total of 800 MW connected to one voltage level and 200 MW connected to another voltage level. How do I determine my gross capacity? Where do I consider Automatic Reclosing to be applicable?

Scenario number 1:

The 800 MW of generation is connected to a BES voltage level bus, the 200 MW is connected to a non-BES voltage level bus, and there is no connection between the two buses locally or within 10 circuit miles from the generating plant substation. The largest single unit in the BA area is 750 MW.

In this case, the total installed gross generating capacity would be 800 MW. The two units are essentially independent plants.

The BES voltage level bus is considered to be the bus to which the 800 MW of generation is connected. Any BES Automatic Reclosing at this location, as well as other locations within 10 circuit miles, is considered to be applicable because 800 MW exceeds the largest single unit in the BA area.

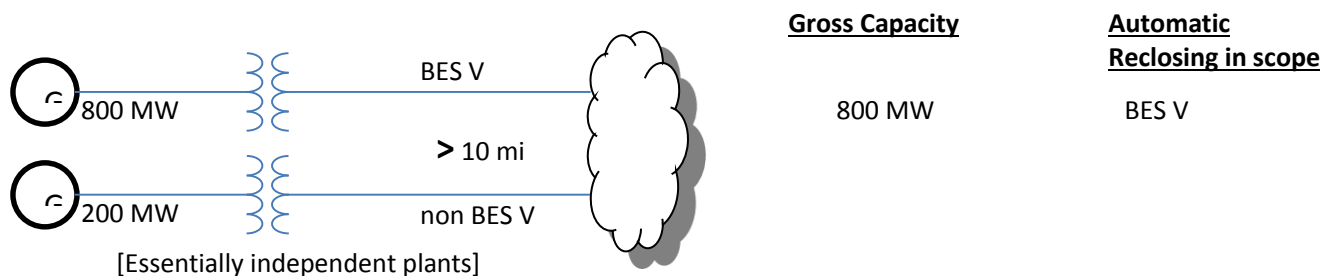

Scenario number 2:

The 800 MW of generation is connected to a BES voltage level bus, the 200 MW unit is connected to a non-BES voltage level bus, and there is a connection between the two buses locally or within 10 circuit miles from the generating plant substation. The largest single unit in the BA area is 750 MW.

In this case, reclosing into a fault on the BES system could impact the stability of the non-BES-connected generating units. Therefore, the total installed gross generating capacity would be 1000 MW.

The BES voltage level bus is considered to be the bus to which the 800 MW of generation is connected. Any BES Automatic Reclosing at this location, as well as other locations within 10 circuit miles, is considered to be applicable because total of 1000 MW exceeds the largest single unit in the BA area. However, the Automatic Reclosing on the non-BES voltage level bus is not applicable.

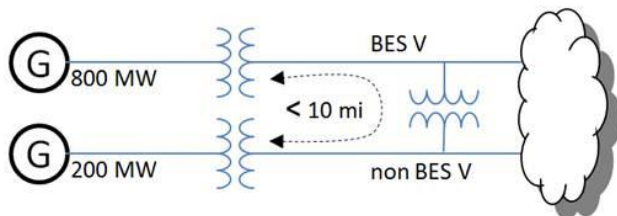
**Gross Capacity**

1000 MW

Automatic Reclosing in scope

BES V

Scenario number 3:

The 800 MW of generation is connected to a BES voltage level bus, the 200 MW unit is connected to a non-BES voltage level bus, and there is no connection between the two buses locally or within 10 circuit miles from the generating plant substation but the generating units connected at the BES voltage level do not operate independently of the units connected at the non BES voltage level (e.g., a combined cycle facility where 800 MW of combustion turbines are connected at a BES voltage level whose exhaust is used to power a 200 MW steam unit connected to a non BES voltage level. The largest single unit in the BA area is 750 MW.

In this case, the total installed gross generating capacity would be 1000 MW. Therefore, reclosing into a fault on the BES voltage level would result in a loss of the 800 MW combustion turbines and subsequently result in the loss of the 200 MW steam unit because of the loss of the heat source to its boiler.

The BES voltage level bus is considered to be the bus to which the 800 MW of generation is connected. Any BES Automatic Reclosing at this location, as well as other locations within 10 circuit miles, is considered to be applicable because total of 1000 MW exceeds the largest single unit in the BA area. However, the Automatic Reclosing on the non-BES voltage level bus is not applicable.

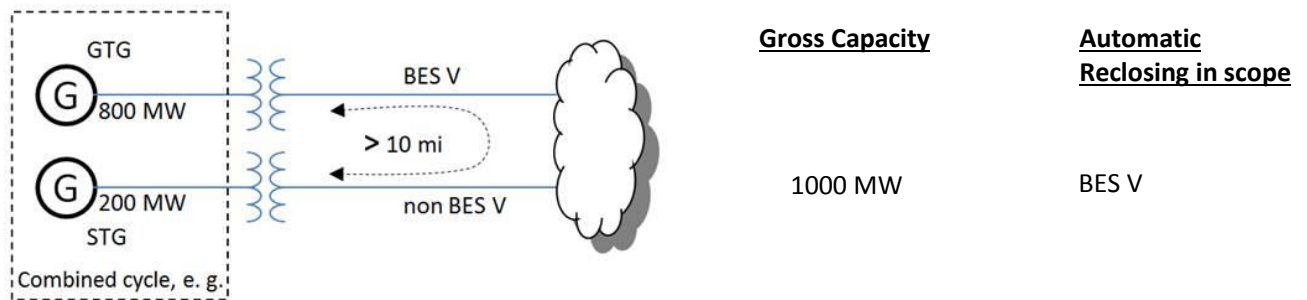

Scenario 4

The 800 MW of generation is connected at 345 kV and the 200 MW is connected at 138 kV with an autotransformer at the generating plant substation connecting the two voltage levels. The largest single unit in the BA area is 900 MW.

In this case, the total installed gross generating capacity would be 1000 MW and section 4.2.76.1 would be applicable to both the 345 kV Automatic Reclosing Components and the 138 kV Automatic Reclosing Components, since the total capacity of 1000 MW is larger than the largest single unit in the BA area.

However, if the 345 kV and the 138 kV systems can be shown to be uncoupled such that the 138 kV reclosing relays will not affect the stability of the 345 kV generating units then the 138 kV Automatic Reclosing Components need not be included per section 4.2.76.1.

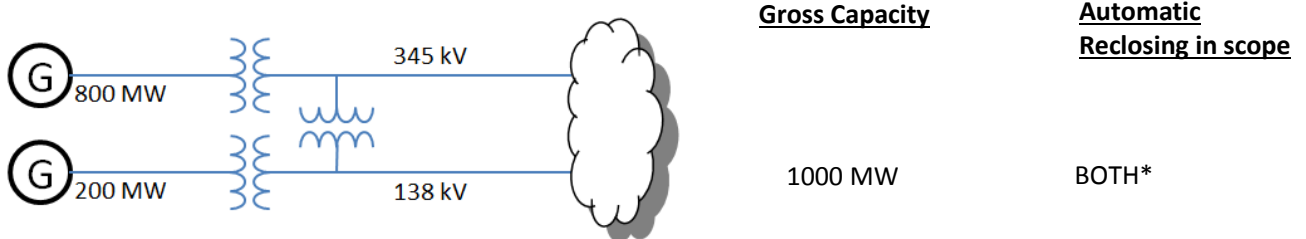

* The study detailed in Footnote 1 of the draft standard may eliminate the 138 kV Automatic Reclosing Components and/or the 345 kV Automatic Reclosing Components

Why does 4.2.76.2 specify "10 circuit miles"?

As noted in "Considerations for Maintenance and Testing of Autoreclosing Schemes — November 2012", transmission line impedance on the order of one mile away typically provides adequate impedance to prevent generating unit instability and a 10 mile threshold provides sufficient margin.

Should I use MVA or MW when determining the installed gross generating plant capacity?

Be consistent with the rating used by the Balancing Authority for the largest BES generating unit within their area.

What value should we use for generating plant capacity in 4.2.76.1?

Use the value reported to the Balance Authority for generating plant capacity for planning and modeling purposes. This can be nameplate or other values based on generating plant limitations such as boiler or turbine ratings.

What is considered to be "one bus away" from the generation?

The BES voltage level bus is considered to be the generating plant substation bus to which the generator step-up transformer is connected. "One bus away" is the next bus, connected by either a transmission line or transformer.

I use my protective relays only as sources of metered quantities and breaker status for SCADA and EMS through a substation distributed RTU or data concentrator to the control center. What are the maintenance requirements for the relays?

This standard addresses Protection Systems that are installed for the purpose of detecting Faults on BES Elements (e.g. lines, buses, transformers, etc.). Protective relays, providing only the functions mentioned in the question, are not included.

Are Reverse Power Relays installed on the low-voltage side of distribution banks considered to be components of "Protection Systems that are installed for the purpose of detecting Faults on BES Elements (lines, buses, transformers, etc.)?"

Reverse power relays are often installed to detect situations where the transmission source becomes de-energized and the distribution bank remains energized from a source on the low-voltage side of the transformer and the settings are calculated based on the charging current of the transformer from the low-voltage side. Although these relays may operate as a result of a fault on a BES element, they are not "installed for the purpose of detecting" these faults.

Why is the maintenance of Sudden Pressure Relaying being addressed in PRC-005-4-6?

Proper performance of Sudden Pressure Relaying supports the reliability of the BES because fault pressure relays can detect rapid changes in gas pressure, oil pressure, or oil flow that are indicative of faults within liquid-filled, wire-wound equipment such as turn-to-turn faults which may be undetected by Protection Systems. Additionally, Sudden Pressure

Relaying can quickly detect faults and operate to limit damage to liquid-filled, wire-wound equipment.

What type of devices are classified as fault pressure relay?

There are three main types of fault pressure relays; rapid gas pressure rise, rapid oil pressure rise, and rapid oil flow devices.

Rapid gas pressure devices monitor the pressure in the space above the oil (or other liquid), and initiate tripping action for a rapid rise in gas pressure resulting from the rapid expansion of the liquid caused by a fault. The sensor is located in the gas space.

Rapid oil pressure devices monitor the pressure in the oil (or other liquid), and initiate tripping action for a rapid pressure rise caused by a fault. The sensor is located in the liquid.

Rapid oil flow devices, (“Buchholz”) monitor the liquid flow between a transformer/reactor and its conservator. Normal liquid flow occurs continuously with ambient temperature changes and with internal heating from loading and does not operate the rapid oil flow device. However, when an internal arc happens-occurs, a sudden expansion of liquid can be monitored as rapid liquid flow from the transformer into the conservator resulting in actuation of the rapid oil flow device.

Are sudden pressure relays that only initiate an alarm included in the scope of PRC-005-4-6?

No, the definition of Sudden Pressure Relaying specifies only those that trip an interrupting device(s) to isolate the equipment it is monitoring.

Are pressure relief devices included in the scope of PRC-005-4-6?

No, PRDs are not included in the Sudden Pressure Relaying definition.

Is Sudden Pressure Relaying installed on distribution transformers included in PRC-005-4-6?

No, Applicability 4.2.1, 4.2.5.2, 4.2.5.3, 4.2.5, and 4.2.6, explicitly describes what Sudden Pressure Relaying is included within the standard.

Are non-electrical sensing devices (other than fault pressure relays) such as low oil level or high winding temperatures included in PRC-005-4-6?

No, based on the SPCS technical document, “Sudden Pressure Relays and Other Devices that Respond to Non-Electrical Quantities – December 2013,” the only applicable non-electrical sensing devices are Sudden Pressure Relays.

The standard specifically mentions auxiliary and lock-out relays. What is an auxiliary tripping relay?

An auxiliary relay, IEEE Device No. 94, is described in IEEE Standard C37.2-2008 as: “A device that functions to trip a circuit breaker, contactor, or equipment; to permit immediate tripping by other devices; or to prevent immediate reclosing of a circuit interrupter if it should open automatically, even though its closing circuit is maintained closed.”

What is a lock-out relay?

A lock-out relay, IEEE Device No. 86, is described in IEEE Standard C37.2 as: “A device that trips and maintains the associated equipment or devices inoperative until it is reset by an operator, either locally or remotely.”

3. Protection System and Automatic Reclosing Product Generations

The likelihood of failure and the ability to observe the operational state of a critical Protection System and Automatic Reclosing both depend on the technological generation of the relays, as well as how long they have been in service. Unlike many other transmission asset groups, protection and control systems have seen dramatic technological changes spanning several generations. During the past 20 years, major functional advances are primarily due to the introduction of microprocessor technology for power system devices, such as primary measuring relays, monitoring devices, control Systemssystems, and telecommunications equipment.

Modern microprocessor-based relays have six significant traits that impact a maintenance strategy:

- Self-monitoring capability - the processors can check themselves, peripheral circuits, and some connected substation inputs and outputs, such as trip coil continuity. Most relay users are aware that these relays have self-monitoring, but are not focusing focused on exactly what internal functions are actually being monitored. As explained further below, every element critical to the Protection System must be monitored, or else verified periodically.
- Ability to capture Fault records showing how the Protection System responded to a Fault in its zone of protection, or to a nearby Fault for which it is required not to operate.
- Ability to meter currents and voltages, as well as status of connected circuit breakers, continuously during non-Fault times. The relays can compute values, such as MW and MVAR line flows, that are sometimes used for operational purposes, such as SCADA.
- Data communications via ports that provide remote access to all of the results of Protection System monitoring, recording and measurement.
- Ability to trip or close circuit breakers and switches through the Protection System outputs, on command from remote data communications messages, or from relay front panel button requests.
- Construction from electronic components, some of which have shorter technical life or service life than electromechanical components of prior Protection System generations.

There have been significant advances in the technology behind the other components of Protection Systems. Microprocessors are now a part of battery chargers, associated communications equipment, voltage and current-measuring devices, and even the control circuitry (in the form of software-latches replacing lock-out relays, etc.).

Any Protection System component can have self-monitoring and alarming capability, not just relays. Because of this technology, extended time intervals for maintenance and inspection can find their way into all components of the Protection System.

This standard also recognizes the distinct advantage of using advanced technology to justifiably defer or even eliminate traditional maintenance. Just as a hand-held calculator does not require routine testing and calibration, neither does a calculation buried in a microprocessor-based device that results in a “lock-out.” Thus, the software-latch 86 that replaces an electro-mechanical 86 does not require routine trip testing. Any trip circuitry associated with the “soft 86” would still need applicable verification activities performed, but the actual “86” does not have to be “electrically operated” or even toggled.

4. Definitions

Protection System Maintenance Program (PSMP) — An ongoing program by which Protection System, Automatic Reclosing and Sudden Pressure Relaying Components are kept in working order and proper operation of malfunctioning Components is restored. A maintenance program for a specific Component includes one or more of the following activities:

- Verify — Determine that the Component is functioning correctly.
- Monitor — Observe the routine in-service operation of the Component.
- Test — Apply signals to a Component to observe functional performance or output behavior, or to diagnose problems.
- Inspect — Examine for signs of Component failure, reduced performance and degradation.
- Calibrate — Adjust the operating threshold or measurement accuracy of a measuring element to meet the intended performance requirement.

Automatic Reclosing – Includes the following Components:

- Reclosing relay
- Supervisory relay(s) or function(s) – relay(s) or function(s) that perform voltage and/or sync check functions that enables or disables operation of the reclosing relay
- Voltage sensing devices associated with the supervisory relay(s)
- Control circuitry associated with the reclosing relay or supervisory relay(s).

Sudden Pressure Relaying – A system that trips an interrupting device(s) to isolate the equipment it is monitoring and includes the following Components:

- Fault pressure relay – a mechanical relay or device that detects rapid changes in gas pressure, oil pressure, or oil flow that are indicative of faults within liquid-filled, wire-wound equipment
- Control circuitry associated with a fault pressure relay

Unresolved Maintenance Issue – A deficiency identified during a maintenance activity that causes the component to not meet the intended performance, cannot be corrected during the maintenance interval, and requires follow-up corrective action.

Segment – Components of a consistent design standard, or a particular model or type from a single manufacturer that typically share other common elements. Consistent performance is expected across the entire population of a Segment. A Segment must contain at least sixty (60) individual Components.

Component Type –

- Any one of the five specific elements of a Protection System.
- Any one of the two-four specific elements of Automatic Reclosing.
- Any one of the two specific elements of Sudden Pressure Relaying.

Component – Any individual discrete piece of equipment included in a Protection System, Automatic Reclosing, or Sudden Pressure Relaying.

Countable Event – A failure of a Component requiring repair or replacement, any condition discovered during the maintenance activities in Tables 1-1 through 1-5, Table 3, Tables 4-1 through 4-3~~2~~, and Table 5, which requires corrective action or a Protection System Misoperation attributed to hardware failure or calibration failure. Misoperations due to product design errors, software errors, relay settings different from specified settings, Protection System Component, Automatic Reclosing or Sudden Pressure Relaying configuration or application errors are not included in Countable Events.

4.1 Frequently Asked Questions:

Why does PRC-005-4-6 not specifically require maintenance and testing procedures, as reflected in the previous standard, PRC-005-1?

PRC-005-1 does not require detailed maintenance and testing procedures, but instead requires summaries of such procedures, and is not clear on what is actually required. PRC-005-4-6 requires a documented maintenance program, and is focused on establishing requirements rather than prescribing methodology to meet those requirements. Between the activities identified in the Tables 1-1 through 1-5, Table 2, Table 3, and Table 4 (collectively the “Tables”), and the various components of the definition established for a “Protection System Maintenance Program,” PRC-005-4-6 establishes the activities and time basis for a Protection System Maintenance Program to a level of detail not previously required.

Please clarify what is meant by “restore” in the definition of maintenance.

The description of “restore” in the definition of a Protection System Maintenance Program addresses corrective activities necessary to assure that the component is returned to working order following the discovery of its failure or malfunction. The Maintenance Activities specified in the Tables do not present any requirements related to Restoration; Requirement R5 of the standard does require that the entity “shall demonstrate efforts to correct any identified Unresolved Maintenance Issues.” Some examples of restoration (or correction of Unresolved Maintenance Issues) include, but are not limited to, replacement of capacitors in distance relays to bring them to working order; replacement of relays, or other Protection System components, to bring the Protection System to working order; upgrade of electromechanical or solid-state protective relays to microprocessor-based relays following the discovery of failed components. Restoration, as used in this context, is not to be confused with restoration rules as used in system operations. Maintenance activity necessarily includes both the detection of problems and the repairs needed to eliminate those problems. This standard does not identify all of the Protection System problems that must be detected and eliminated, rather it is the intent of this standard that an entity determines the necessary working order for their various devices, and keeps them in working order. If an equipment item is repaired or replaced, then the entity can restart the maintenance-time-interval-clock, if desired; however, the replacement of equipment does not remove any documentation requirements that would have been required to verify compliance with time-interval requirements. In other words, do not discard maintenance data that goes to verify your work.

The retention of documentation for new and/or replaced equipment ~~is all about proving~~ provides evidence that the maintenance intervals ~~had/have/had~~ had/have/had been ~~in~~ compliance-compliant/compliance. For example, a long-range plan of upgrades might lead an

entity to ignore required maintenance; retaining the evidence of prior maintenance that existed before any retirements and upgrades proves compliance with the standard.

Please clarify what is meant by “...demonstrate efforts to correct an Unresolved Maintenance Issue...;” why not measure the completion of the corrective action?

Management of completion of the identified Unresolved Maintenance Issue is a complex topic that falls outside of the scope of this standard. There can be any number of supply, process and management problems that make setting repair deadlines impossible. The SDT specifically chose the phrase “demonstrate efforts to correct” (with guidance from NERC Staff) because of the concern that many more complex Unresolved Maintenance Issues might require greater than the remaining maintenance interval to resolve (and yet still be a “closed-end process”). For example, a problem might be identified on a VRLA battery during a six-month check. In instances such as one that requiring battery replacement as part of the long-term resolution, it is highly unlikely that the battery could be replaced in time to meet the six-calendar-month requirement for this maintenance activity. The SDT does not believe entities should be found in violation of a maintenance program requirement because of the inability to complete a remediation program within the original maintenance interval. The SDT does believe corrective actions should be timely, but concludes it would be impossible to postulate all possible remediation projects; and, therefore, impossible to specify bounding time frames for resolution of all possible Unresolved Maintenance Issues, or what documentation might be sufficient to provide proof that effective corrective action is being undertaken.

5. Time-Based Maintenance (TBM) Programs

Time-based maintenance is the process in which Protection System, Automatic Reclosing and Sudden Pressure Relaying Components are maintained or verified according to a time schedule. The scheduled program often calls for technicians to travel to the physical site and perform a functional test on Protection System components. However, some components of a TBM program may be conducted from a remote location—for example, tripping a circuit breaker by communicating a trip command to a microprocessor relay to determine if the entire Protection System tripping chain is able to operate the breaker. Similarly, all Protection System, —and Sudden Pressure Relaying Components, can have the ability to remotely conduct tests, either on-command or routinely; the running of these tests can extend the time interval between hands-on maintenance activities.

5.1 Maintenance Practices

Maintenance and testing programs often incorporate the following types of maintenance practices:

- TBM – time-based maintenance – externally prescribed maximum maintenance or testing intervals are applied for components or groups of components. The intervals may have been developed from prior experience or manufacturers’ recommendations. The TBM verification interval ~~can be~~ based on a variety of factors, including experience of the particular asset owner, collective experiences of several asset owners who are members of a country or regional council, etc. The maintenance intervals are fixed and may range in number ~~from~~ months ~~or into~~ years.

TBM can include review of recent power system events near the particular terminal. Operating records may verify that some portion of the Protection System has operated correctly since the last test occurred. If specific protection scheme components have demonstrated correct performance within specifications, the maintenance test time clock can be reset for those components.

- PBM – Performance-Based Maintenance - intervals are established based on analytical or historical results of TBM failure rates on a statistically significant population of similar components. Some level of TBM is generally followed. Statistical analyses accompanied by adjustments to maintenance intervals are used to justify continued use of PBM-developed extended intervals when test failures or in-service failures occur infrequently.
- CBM – condition-based maintenance – continuously or frequently reported results from non-disruptive self-monitoring of components demonstrate operational status as those components remain in service. Whatever is verified by CBM does not require manual testing, but taking advantage of this requires precise technical focus on exactly what parts are included as part of the self-diagnostics. While the term “Condition-Based-Maintenance” (CBM) is no longer used within the standard itself, it is important to note that the concepts of CBM are a part of the standard (in the form of extended time intervals through status-monitoring). These extended time intervals are only allowed (in the absence of PBM) if the condition of the device is ~~continuously~~ monitored (CBM). As a consequence of the “monitored-basis-time-intervals” existing within the standard, the

explanatory discussions within this Supplementary Reference concerned with CBM will remain in this reference and are discussed as CBM.

Microprocessor-based Protection System or Automatic Reclosing Components that perform continuous self-monitoring verify correct operation of most components within the device. Self-monitoring capabilities may include battery continuity, float voltages, unintentional grounds, the ac signal inputs to a relay, analog measuring circuits, processors and memory for measurement, protection, and data communications, trip circuit monitoring, and protection or data communications signals (and many, many more measurements). For those conditions, failure of a self-monitoring routine generates an alarm and may inhibit operation to avoid false trips. When internal components, such as critical output relay contacts, are not equipped with self-monitoring, they can be manually tested. The method of testing may be local or remote, or through inherent performance of the scheme during a system event.

The TBM is the overarching maintenance process of which the other types are subsets. Unlike TBM, PBM intervals are adjusted based on good or bad experiences. The CBM verification intervals can be hours, or even milliseconds between non-disruptive self-monitoring checks within or around components as they remain in service.

TBM, PBM, and CBM can be combined for individual components, or within a complete Protection System. The following diagram illustrates the relationship between various types of maintenance practices described in this section. In the Venn diagram, the overlapping regions show the relationship of TBM with PBM historical information and the inherent continuous monitoring offered through CBM.

This figure shows:

- Region 1: The TBM intervals that are increased based on known reported operational condition of individual components that are monitoring themselves.
- Region 2: The TBM intervals that are adjusted up or down based on results of analysis of maintenance history of statistically significant population of similar products that have been subject to TBM.
- Region 3: Optimal TBM intervals based on regions 1 and 2.

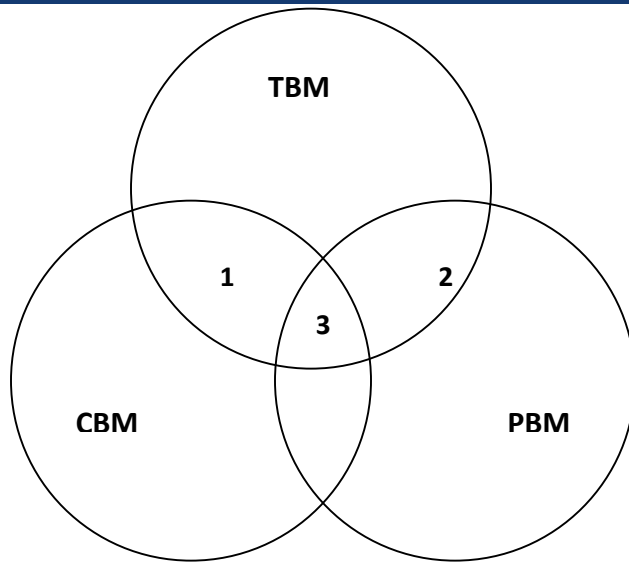

Relationship of time-based maintenance types

5.1.1 Frequently Asked Questions:

The standard seems very complicated, and is difficult to understand. Can it be simplified?

Because the standard is establishing parameters for condition-based Maintenance ([Requirement R1](#)) and Performance-Based Maintenance ([Requirement R2](#)), in addition to simple time-based Maintenance, it does appear to be complicated. At its simplest, an entity needs to ONLY perform time-based maintenance according to the unmonitored rows of the Tables. If an entity then wishes to take advantage of monitoring on its Protection System components and its available lengthened time intervals, then it may, as long as the component has the listed monitoring attributes. If an entity wishes to use historical performance of its Protection System components to perform Performance-Based Maintenance, then [Requirement R2](#) applies.

Please see the following diagram, which provides a “flow chart” of the standard.

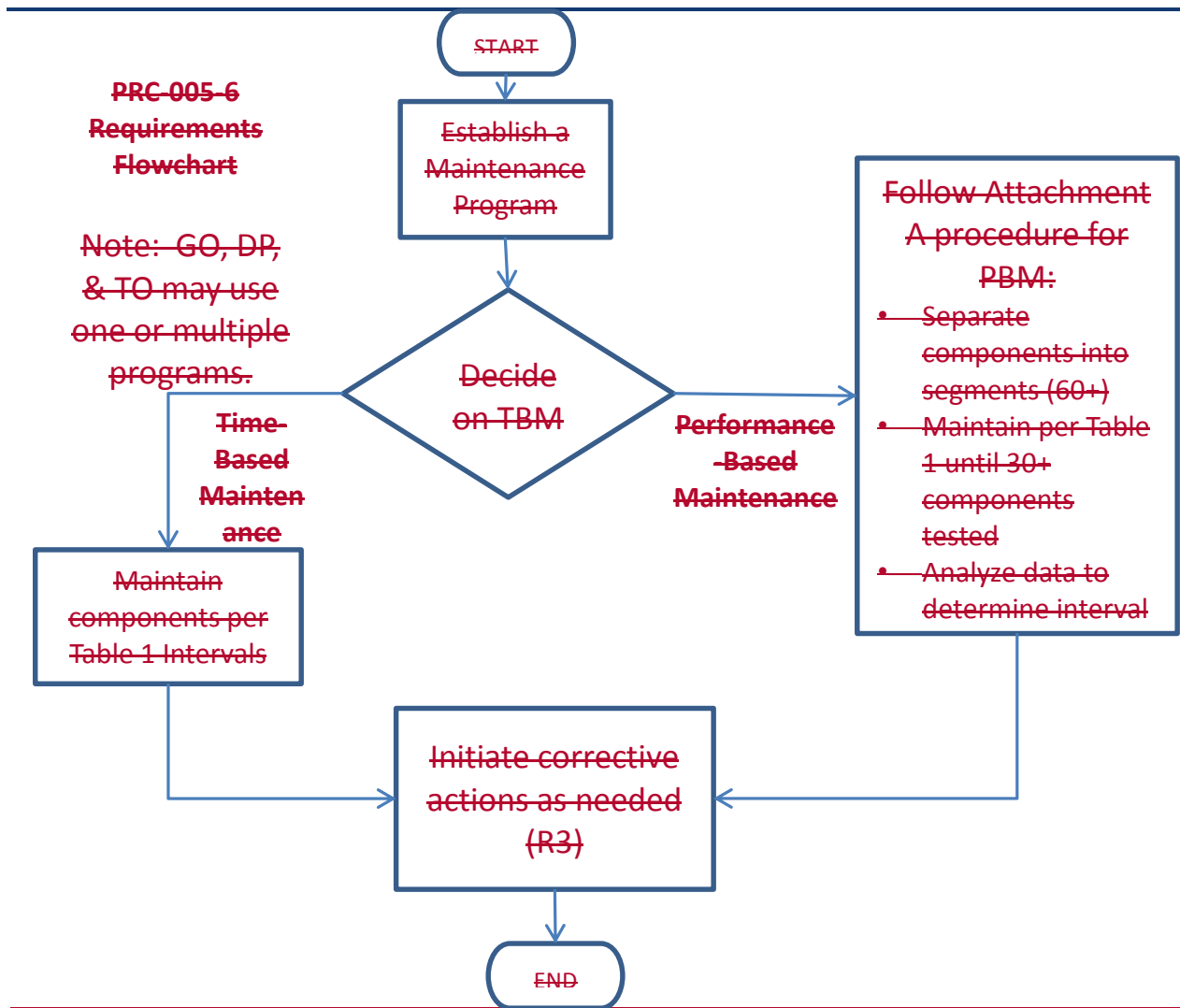

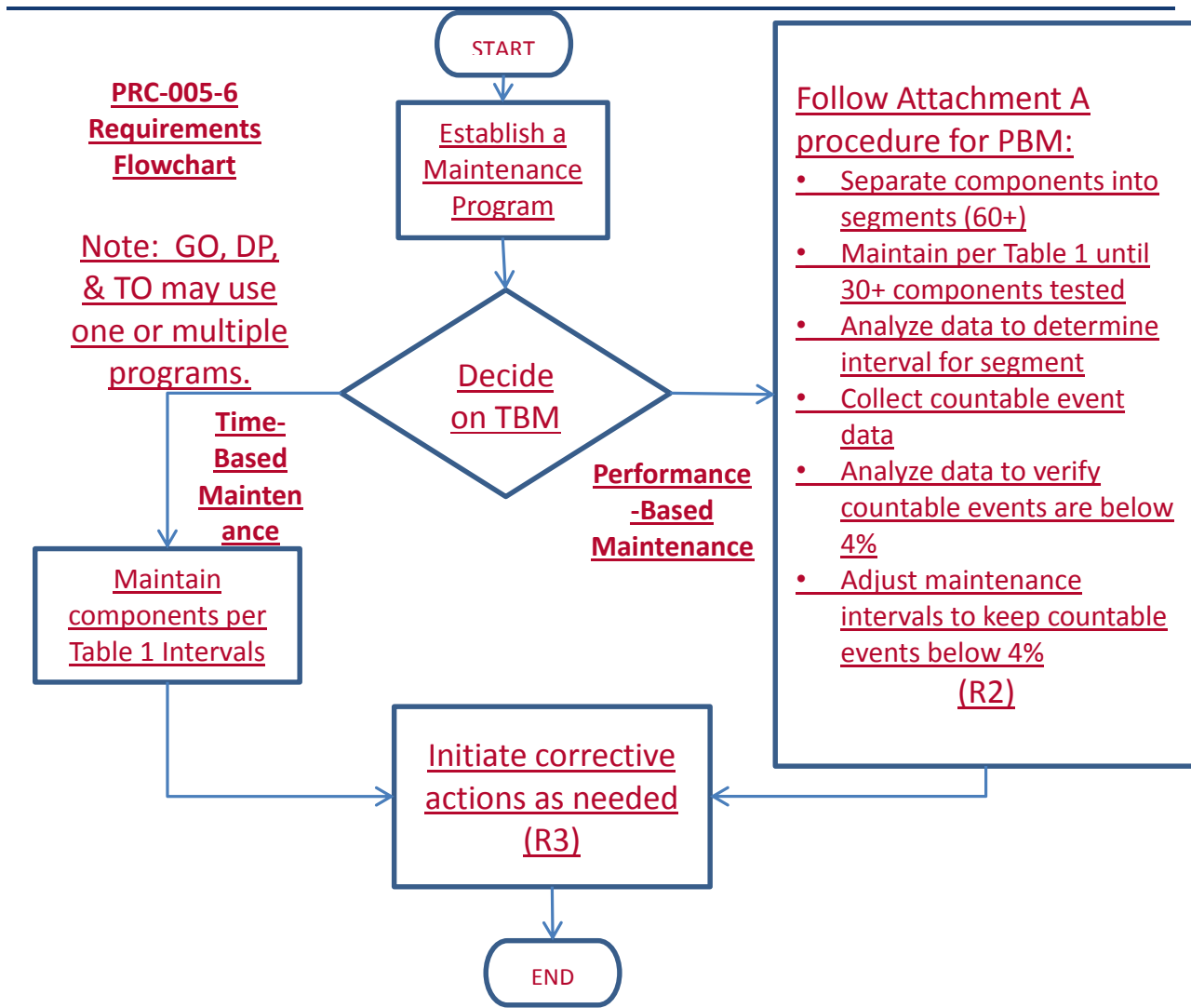

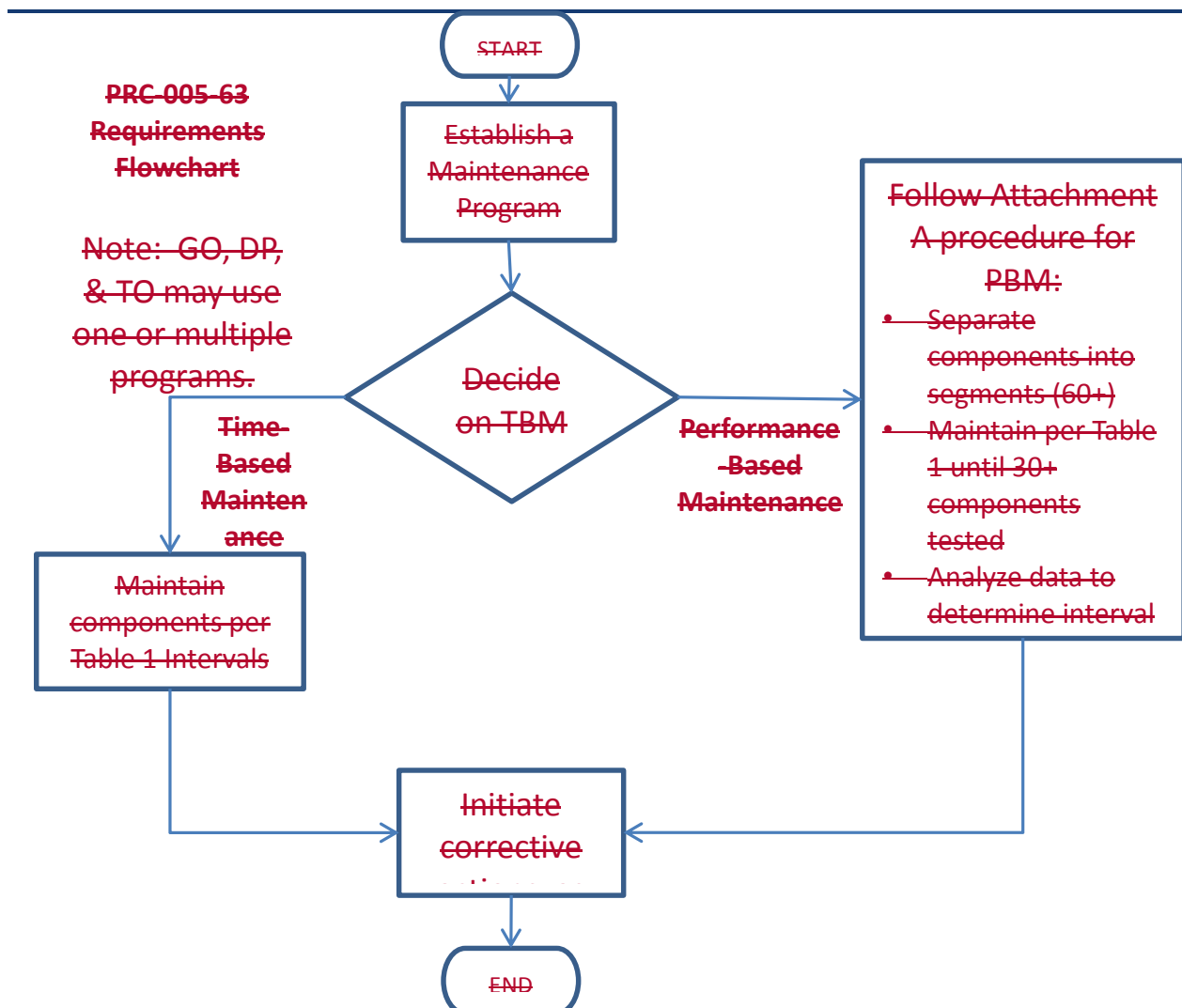

We have an electromechanical (unmonitored) relay that has a trip output to a lockout relay (unmonitored) which trips our transformer off-line by tripping the transformer’s high-side and low-side circuit breakers. What testing must be done for this system?

This system is made up of components that are all unmonitored. Assuming a time-based Protection System Maintenance Program schedule (as opposed to a Performance-Based maintenance program), each component must be maintained per the most frequent hands-on activities listed in the Tables.

5.2 Extending Time-Based Maintenance

All maintenance is fundamentally time-based. Default time-based intervals are commonly established to assure proper functioning of each component of the Protection System, when data on the reliability of the components is not available other than observations from time-based maintenance. The following factors may influence the established default intervals:

- If continuous indication of the functional condition of a component is available (from relays or chargers or any self-monitoring device), then the intervals may be extended, or manual testing may be eliminated. This is referred to as condition-based maintenance or

CBM. CBM is valid only for precisely the components subject to monitoring. In the case of microprocessor-based relays, self-monitoring may not include automated diagnostics of every component within a microprocessor.

- Previous maintenance history for a group of components of a common type may indicate that the maintenance intervals can be extended, while still achieving the desired level of performance. This is referred to as Performance-Based Maintenance, or PBM. It is also sometimes referred to as reliability-centered maintenance, or RCM; but PBM is used in this document.
- Observed proper operation of a component may be regarded as a maintenance verification of the respective component or element in a microprocessor-based device. For such an observation, the maintenance interval may be reset only to the degree that can be verified by data available on the operation. For example, the trip of an electromechanical relay for a Fault verifies the trip contact and trip path, but only through the relays in series that actually operated; one operation of this relay cannot verify correct calibration.

Excessive maintenance can actually decrease the reliability of the component or system. It is not unusual to cause failure of a component by removing it from service and restoring it. The improper application of test signals may cause failure of a component. For example, in electromechanical overcurrent relays, test currents have been known to destroy convolution springs.

In addition, maintenance usually takes the component out of service, during which time it is not able to perform its function. Cutout switch failures, or failure to restore switch position, commonly lead to protection failures.

5.2.1 Frequently Asked Questions:

If I show the protective device out of service while it is being repaired, then can I add it back as a new protective device when it returns? If not, my relay testing history would show that I was out of compliance for the last maintenance cycle.

The maintenance and testing requirements (R5) (in essence) state "...shall demonstrate efforts to correct ~~any~~ identified Unresolved Maintenance Issues." The type of corrective activity is not stated; however, ~~it~~ it could include repairs or replacements.

Your documentation requirements will increase, of course, to demonstrate that your device ~~tested bad failed~~ and had corrective actions initiated. Your regional entity ~~could very well will~~ likely ask for request documentation showing the status of your corrective actions.

6. Condition-Based Maintenance (CBM) Programs

Condition-based maintenance is the process of gathering and monitoring the information available from modern microprocessor-based relays and other intelligent electronic devices (IEDs) that monitor Protection System or Automatic Reclosing elements. These devices generate monitoring information during normal operation, and the information can be assessed at a convenient location remote from the substation. The information from these relays and IEDs is divided into two basic types:

1. Information can come from background self-monitoring processes, programmed by the manufacturer, or by the user in device logic settings. The results are presented by alarm contacts or points, front panel indications, and by data communications messages.
2. Information can come from event logs, captured files, and/or oscillographic records for Faults and Disturbances, metered values, and binary input status reports. Some of these are available on the device front panel display, but may be available via data communications ports. Large files of Fault information can only be retrieved via data communications. These results comprise a mass of data that must be further analyzed for evidence of the operational condition of the Protection System.

Using these two types of information, the user can develop an effective maintenance program carried out mostly from a central location remote from the substation. This approach offers the following advantages:

Non-invasive Maintenance: The system is kept in its normal operating state, without human intervention for checking. This reduces risk of damage, or risk of leaving the system in an inoperable state after a manual test. Experience has shown that keeping human hands away from equipment known to be working correctly enhances reliability.

Virtually Continuous Monitoring: CBM will report many hardware failure problems for repair within seconds or minutes of when they happen. This reduces the percentage of problems that are discovered through incorrect relaying performance. By contrast, a hardware failure discovered by TBM may have been ~~there~~ present for much of the time interval between tests, and there is a good chance that some devices will show health problems by incorrect operation before being caught in the next test round. The frequent or continuous nature of CBM makes the effective verification interval far shorter than any required TBM maximum interval. To use the extended time intervals available through Condition Based Maintenance, simply look for the rows in the Tables that refer to monitored items.

6.1 Frequently Asked Questions:

My microprocessor relays and dc circuit alarms are contained on relay panels in a 24-hour attended control room. Does this qualify as an extended time interval condition-based (monitored) system?

Yes, provided the station attendant (plant operator, etc.) monitors the alarms and other indications (comparable to the monitoring attributes) and reports them within the given time limits that are stated in the criteria of the Tables.

When documenting the basis for inclusion of components into the appropriate levels of monitoring, as per Requirement R1 (Part 1.2) of the standard, is it necessary to provide this documentation about the device by listing of every component and the specific monitoring attributes of each device?

No. While maintaining this documentation on the device level would certainly be permissible, it is not necessary. Global statements can be made to document appropriate levels of monitoring for the entire population of a component type or portion thereof.

For example, it would be permissible to document the conclusion that all BES substation dc supply battery chargers are monitored by stating the following within the program description:

“All substation dc supply battery chargers are considered monitored and subject to the rows for monitored equipment of Table 1-4 requirements, as all substation dc supply battery chargers are equipped with dc voltage alarms and ground detection alarms that are sent to the manned control center.”

Similarly, it would be acceptable to use a combination of a global statement and a device-level list of exclusions. Example:

“Except as noted below, all substation dc supply battery chargers are considered monitored and subject to the rows for monitored equipment of Table 1-4 requirements, as all substation dc supply battery chargers are equipped with dc voltage alarms and ground detection alarms that are sent to the manned control center. The dc supply battery chargers of Substation X, Substation Y, and Substation Z are considered unmonitored and subject to the rows for unmonitored equipment in Table 1-4 requirements, as they are not equipped with ground detection capability.”

Regardless whether this documentation is provided by device listing of monitoring attributes, by global statements of the monitoring attributes of an entire population of component types, or by some combination of these methods, it should be noted that auditors may request supporting drawings or other documentation necessary to validate the inclusion of the device(s) within the appropriate level of monitoring. This supporting background information need not be maintained within the program document structure, but should be retrievable if requested by an auditor.

7. Time-Based Versus Condition-Based Maintenance

Time-based and condition-based (or monitored) maintenance programs are both acceptable, if implemented according to technically sound requirements. Practical programs can employ a combination of time-based and condition-based maintenance. The standard requirements introduce the concept of optionally using condition monitoring as a documented element of a maintenance program.

The Federal Energy Regulatory Commission (FERC), in its Order Number 693 Final Rule, dated March 16, 2007 (18 CFR Part 40, Docket No. RM06-16-000) on Mandatory Reliability Standards for the Bulk-Power System, directed NERC to submit a modification to PRC-005-1b that includes a requirement that maintenance and testing of a Protection System must be carried out within a maximum allowable interval that is appropriate to the type of the Protection System and its impact on the reliability of the Bulk Power System. Accordingly, this Supplementary Reference Paper refers to the specific maximum allowable intervals in PRC-005-~~4~~6. The defined time limits allow for longer time intervals if the maintained component is monitored.

A key feature of condition-based monitoring is that it effectively reduces the time delay between the moment of a protection failure and time the Protection System or Automatic Reclosing owner knows about it, for the monitored segments of the Protection System. In some cases, the verification is practically continuous—the time interval between verifications is minutes or seconds. Thus, technically sound, condition-based verification, meets the verification requirements of the FERC order even more effectively than the strictly time-based tests of the same system components.

The result is that:

This NERC standard permits utilities to use a technically sound approach and to take advantage of remote monitoring, data analysis, and control capabilities of modern Protection System and Automatic Reclosing Components to reduce the need for periodic site visits and invasive testing of components by on-site technicians. This periodic testing must be conducted within the maximum time intervals specified in the Tables of PRC-005-~~4~~6.

7.1 Frequently Asked Questions:

What is a Calendar Year?

Calendar Year - January 1 through December 31 of any year. As an example, if an event occurred on June 17, 2009 and is on a “One Calendar Year Interval,” the next event would have to occur on or before December 31, 2010.

Please provide an example of "4 Calendar Months".

If a maintenance activity is described as being needed every four Calendar Months then it is performed in a (given) month and due again four months later. For example a battery bank is inspected in month number 1 then it is due again before the end of the month number 5. And specifically consider that you perform your battery inspection on January 3, 2010 then it must be inspected again before the end of May. Another example could be that a four-month inspection

was performed in January is due in May, but if performed in March (instead of May) would still be due four months later therefore the activity is due again July. Basically every “four Calendar Months” means to add four months from the last time the activity was performed and perform the activity by the end of the fourth month.

Please provide an example of the unmonitored versus other levels of monitoring available?

An unmonitored Protection System has no monitoring and alarm circuits on the Protection System components. A Protection System component that has monitoring attributes but no alarm output connected is considered to be unmonitored.

A monitored Protection System or an individual monitored component of a Protection System has monitoring and alarm circuits on the Protection System components. The alarm circuits must alert, within 24 hours, a location wherein corrective action can be initiated. This location might be, but is not limited to, an Operations Center, Dispatch Office, Maintenance Center or even a portable SCADA system.

There can be a combination of monitored and unmonitored Protection Systems within any given scheme, substation or plant; there can also be a combination of monitored and unmonitored components within any given Protection System.

Example #1: A combination of monitored and unmonitored components within a given Protection System might be:

- A microprocessor relay with an internal alarm connected to SCADA to alert 24-hr staffed operations center; it has internal self-diagnosis and alarming. (monitored)
- Instrumentation transformers, with no monitoring, connected as inputs to that relay. (unmonitored)
- A vented Lead-Acid battery with a low voltage alarm for the station dc supply voltage and an unintentional grounds detection alarm connected to SCADA. (monitoring varies)
- A circuit breaker with a trip coil, and the trip circuit is not monitored. (unmonitored)

Given the particular components and conditions, and using Table 1 and Table 2, the particular components have maximum activity intervals of:

Every four calendar months, inspect:

- Electrolyte level (station dc supply voltage and unintentional ground detection is being maintained more frequently by the monitoring system).

Every 18 calendar months, verify/inspect the following:

- Battery bank ohmic values to station battery baseline (if performance tests are not opted)
- Battery charger float voltage
- Battery rack integrity
- Cell condition of all individual battery cells (where visible)
- Battery continuity
- Battery terminal connection resistance

-
- Battery cell-to-cell resistance (where available to measure)

Every six calendar years, perform/verify the following:

- Battery performance test (if internal ohmic tests or other measurements indicative of battery performance are not opted)
- Verify that each trip coil is able to operate the circuit breaker, interrupting device, or mitigating device
- For electromechanical lock-out relays, electrical operation of electromechanical trip

Every 12 calendar years, verify the following:

- Microprocessor relay settings are as specified
- Operation of the microprocessor's relay inputs and outputs that are essential to proper functioning of the Protection System
- Acceptable measurement of power System input values seen by the microprocessor protective relay
- Verify that current and voltage signal values are provided to the protective relays
- Protection System component monitoring for the battery system signals are conveyed to a location where corrective action can be initiated
- The microprocessor relay alarm signals are conveyed to a location where corrective action can be initiated
- Verify all trip paths in the control circuitry associated with protective functions through the trip coil(s) of the circuit breakers or other interrupting devices
- Auxiliary outputs that are in the trip path shall be maintained as detailed in Table 1-5 of the standard under the 'Unmonitored Control Circuitry Associated with Protective Functions' section'
- Auxiliary outputs not in a trip path (i.e., annunciation or DME input) are not required, by this standard, to be checked

Example #2: A combination of monitored and unmonitored components within a given Protection System might be:

- A microprocessor relay with integral alarm that is not connected to SCADA. (unmonitored)
- Current and voltage signal values, with no monitoring, connected as inputs to that relay. (unmonitored)
- A vented lead-acid battery with a low voltage alarm for the station dc supply voltage and an unintentional grounds detection alarm connected to SCADA. (monitoring varies)
- A circuit breaker with a trip coil, with no circuits monitored. (unmonitored)

Given the particular components and conditions, and using the Table 1 (Maximum Allowable Testing Intervals and Maintenance Activities) and Table 2 (Alarming Paths and Monitoring), the particular components have maximum activity intervals of:

Every four calendar months, inspect:

- Electrolyte level (station dc supply voltage and unintentional ground detection is being maintained more frequently by the monitoring system)

Every 18 calendar months, verify/inspect the following:

- Battery bank trending of ohmic values or other measurements indicative of battery performance to station battery baseline (if performance tests are not opted)
- Battery charger float voltage
- Battery rack integrity
- Cell condition of all individual battery cells (where visible)
- Battery continuity
- Battery terminal connection resistance
- Battery cell-to-cell resistance (where available to measure)

Every six calendar years, verify/perform the following:

- Verify operation of the relay inputs and outputs that are essential to proper functioning of the Protection System
- Verify acceptable measurement of power system input values as seen by the relays
- Verify that each trip coil is able to operate the circuit breaker, interrupting device, or mitigating device
- For electromechanical lock-out relays, electrical operation of electromechanical trip
- Battery performance test (if internal ohmic tests are not opted)

Every 12 calendar years, verify the following:

- Current and voltage signal values are provided to the protective relays
- Protection System component monitoring for the battery system signals are conveyed to a location where corrective action can be initiated
- All trip paths in the control circuitry associated with protective functions through the trip coil(s) of the circuit breakers or other interrupting devices
- Auxiliary outputs that are in the trip path shall be maintained, as detailed in Table 1-5 of the standard under the Unmonitored Control Circuitry Associated with Protective Functions" section
- Auxiliary outputs not in a trip path (i.e., annunciation or DME input) are not required, by this standard, to be checked

Example #3: A combination of monitored and unmonitored components within a given Protection System might be:

- A microprocessor relay with alarm connected to SCADA to alert 24-hr staffed operations center; it has internal self-diagnosis and alarms. (monitored)
- Current and voltage signal values, with monitoring, connected as inputs to that relay (monitored)

-
- Vented Lead-Acid battery without any alarms connected to SCADA (unmonitored)
 - Circuit breaker with a trip coil, with no circuits monitored (unmonitored)

Given the particular components, conditions, and using the Table 1 (Maximum Allowable Testing Intervals and Maintenance Activities) and Table 2 (Alarming Paths and Monitoring), the particular components shall have maximum activity intervals of:

Every four calendar months, verify/inspect the following:

- Station dc supply voltage
- For unintentional grounds
- Electrolyte level

Every 18 calendar months, verify/inspect the following:

- Battery bank trending of ohmic values or other measurements indicative of battery performance to station battery baseline (if performance tests are not opted)
- Battery charger float voltage
- Battery rack integrity
- Battery continuity
- Battery terminal connection resistance
- Battery cell-to-cell resistance (where available to measure)
- Condition of all individual battery cells (where visible)

Every six calendar years, perform/verify the following:

- Battery performance test (if internal ohmic tests or other measurements indicative of battery performance are not opted)
- Verify that each trip coil is able to operate the circuit breaker, interrupting device, or mitigating device
- For electromechanical lock-out relays, electrical operation of electromechanical trip

Every 12 calendar years, verify the following:

- The microprocessor relay alarm signals are conveyed to a location where corrective action can be taken
- Microprocessor relay settings are as specified
- Operation of the microprocessor's relay inputs and outputs that are essential to proper functioning of the Protection System
- Acceptable measurement of power system input values seen by the microprocessor protective relay
- Verify all trip paths in the control circuitry associated with protective functions through the trip coil(s) of the circuit breakers or other interrupting devices

-
- Auxiliary outputs that are in the trip path shall be maintained, as detailed in Table 1-5 of the standard under the Unmonitored Control Circuitry Associated with Protective Functions section
 - Auxiliary outputs not in a trip path (i.e. annunciation or DME input) are not required, by this standard, to be checked

Why do components have different maintenance activities and intervals if they are monitored?

The ~~intent behind~~rationale supporting different activities and intervals for monitored equipment is to allow less frequent manual intervention when more information is known about the condition of Protection System components. Condition-Based Maintenance is a valuable asset to improve reliability.

Can all components in a Protection System be monitored?

No. ~~---~~For some components in a Protection System, monitoring will not be relevant. For example, a battery will always need some kind of inspection.

We have a 30-year-old oil circuit breaker with a red indicating lamp on the substation relay panel that is illuminated only if there is continuity through the breaker trip coil. There is no SCADA monitor or relay monitor of this trip coil. The line protection relay package that trips this circuit breaker is a microprocessor relay that has an integral alarm relay that will assert on a number of conditions that includes a loss of power to the relay. This alarm contact connects to our SCADA system and alerts our 24-hour operations center of relay trouble when the alarm contact closes. This microprocessor relay trips the circuit breaker only and does not monitor trip coil continuity or other things such as trip current. Are the components monitored or not? How often must I perform maintenance?

The protective relay is monitored and can be maintained every 12 years, or when an Unresolved Maintenance Issue arises. The control circuitry can be maintained every 12 years. The circuit breaker trip coil(s) has to be electrically operated at least once every six years.

What is a mitigating device?

A mitigating device is the device that acts to respond as directed by a Remedial Action Schemes. It may be a breaker, valve, distributed control system, or any variety of other devices. This response may include tripping, closing, or other control actions.

8. Maximum Allowable Verification Intervals

The maximum allowable testing intervals and maintenance activities show how CBM with newer device types can reduce the need for many of the tests and site visits that older Protection System components require. As explained below, there are some sections of the Protection System that monitoring or data analysis may not verify. Verifying these sections of the Protection System or Automatic Reclosing requires some persistent TBM activity in the maintenance program. However, some of this TBM can be carried out remotely—for example, exercising a circuit breaker through the relay tripping circuits using the relay remote control capabilities can be used to verify function of one tripping path and proper trip coil operation, if there has been no Fault or routine operation to demonstrate performance of relay tripping circuits.

8.1 Maintenance Tests

Periodic maintenance testing is performed to ensure that the protection and control system is operating correctly after a time period of field installation. These tests may be used to ensure that individual components are still operating within acceptable performance parameters - this type of test is needed for components susceptible to degraded or changing characteristics due to aging and wear. Full system performance tests may be used to confirm that the total Protection System functions from measurement of power system values, to properly identifying Fault characteristics, to the operation of the interrupting devices.

8.1.1 Table of Maximum Allowable Verification Intervals

Table 1 (collectively known as Table 1, individually called out as Tables 1-1 through 1-5), Table 2, Table 3, Table 4-1 through Table 4-~~32~~, and Table 5 in the standard specify maximum allowable verification intervals for various generations of Protection Systems, Automatic Reclosing and Sudden Pressure Relaying and categories of equipment that comprise these systems. The right column indicates maintenance activities required for each category.

The types of components are illustrated in [Figures 1](#) and [2](#) at the end of this paper. Figure 1 shows an example of telecommunications-assisted transmission Protection System comprising substation equipment at each terminal and a telecommunications channel for relaying between the two substations. [Figure 2](#) shows an example of a generation Protection System. The various sub-systems of a Protection System that need to be verified are shown.

Non-distributed UFLS, UVLS, and RAS are additional categories of Table 1 that are not illustrated in these figures. Non-distributed UFLS, UVLS and RAS all use identical equipment as Protection Systems in the performance of their functions; and, therefore, have the same maintenance needs.

Distributed UFLS and UVLS Systems, which use local sensing on the distribution System and trip co-located non-BES interrupting devices, are addressed in Table 3 with reduced maintenance activities.

While it is easy to associate protective relays to multiple levels of monitoring, it is also true that most of the components that can make up a Protection System can also have technological advancements that place them into higher levels of monitoring.

To use the Maintenance Activities and Intervals Tables from PRC-005-~~4-6~~:

-
- First find the Table associated with your component. The tables are arranged in the order of mention in the definition of Protection System;
 - Table 1-1 is for protective relays,
 - Table 1-2 is for the associated communications systems,
 - Table 1-3 is for current and voltage sensing devices,
 - Table 1-4 is for station dc supply and
 - Table 1-5 is for control circuits.
 - Table 2, is for alarms; this was broken out to simplify the other tables.
 - Table 3 is for components which make-up distributed UFLS and UVLS Systems.
 - Table 4 is for Automatic Reclosing.
 - Table 5 is for Sudden Pressure Relaying.
 - Next, look within that table for your device and its degree of monitoring. The Tables have different hands-on maintenance activities prescribed depending upon the degree to which you monitor your equipment. Find the maintenance activity that applies to the monitoring level that you have on your piece of equipment.
 - This Maintenance activity is the minimum maintenance activity that must be documented.
 - If your Performance-Based Maintenance (PBM) plan requires more activities, then you must perform and document to this higher standard. (Note that this does not apply unless you utilize PBM.)
 - After the maintenance activity is known, check the maximum maintenance interval; this time is the maximum time allowed between hands-on maintenance activity cycles of this component.
 - If your Performance-Based Maintenance plan requires activities more often than the Tables maximum, then you must perform and document those activities to your more stringent standard. (Note that this does not apply unless you utilize PBM.)
 - Any given component of a Protection System can be determined to have a degree of monitoring that may be different from another component within that same Protection System. For example, in a given Protection System it is possible for an entity to have a monitored protective relay and an unmonitored associated communications system; this combination would require hands-on maintenance activity on the relay at least once every 12 years and attention paid to the communications system as often as every four months.
 - An entity does not have to utilize the extended time intervals made available by this use of condition-based monitoring. An easy choice to make is to simply utilize the unmonitored level of maintenance made available in each of the Tables. While the maintenance activities resulting from this choice would require more maintenance man-hours, the maintenance requirements may be simpler to document and the resulting maintenance plans may be easier to create.

For each Protection System Component, Table 1 shows maximum allowable testing intervals for the various degrees of monitoring. For each Automatic Reclosing Component, Table 4 shows maximum allowable testing intervals for the various degrees of monitoring. These degrees of monitoring, or levels, range from the legacy unmonitored through a system that is more comprehensively monitored.

It has been noted here that an entity may have a PSMP that is more stringent than PRC-005-4-6. There may be any number of reasons that an entity chooses a more stringent plan than the minimums prescribed within PRC-005-4-6, most notable of which is an entity using performance based maintenance methodology.

If an entity has a Performance-Based Maintenance program, then that plan must be followed, even if the plan proves to be more stringent than the minimums laid out in the Tables.

If an entity has a Time-Based Maintenance program and the PSMP is more stringent than PRC-005-4-6, they will only be audited in accordance with the standard (minimum maintenance activities and maximum maintenance intervals prescribed within Tables 1-1 through 1-5, Table 2, Table 3, Table 4-1 through 4-32, and Table 5).

8.1.2 Additional Notes for Tables 1-1 through 1-5, Table 3, and Table 4

1. For electromechanical relays, adjustment is required to bring measurement accuracy within the tolerance needed by the asset owner. Microprocessor relays with no remote monitoring of alarm contacts, etc., are unmonitored relays and need to be verified within the Table interval as other unmonitored relays but may be verified as functional by means other than testing by simulated inputs.
2. Microprocessor relays typically are specified by manufacturers as not requiring calibration, but acceptable measurement of power system input values must be verified (verification of the Analog to Digital [A/D] converters) within the Table intervals. The integrity of the digital inputs and outputs that are used as protective functions must be verified within the Table intervals.
3. Any Phasor Measurement Unit (PMU) function whose output is used in a Protection System or RAS (as opposed to a monitoring task) must be verified as a component in a Protection System.
4. In addition to verifying the circuitry that supplies dc to the Protection System, the owner must maintain the station dc supply. The most widespread station dc supply is the station battery and charger. Unlike most Protection System components, physical inspection of station batteries for signs of component failure, reduced performance, and degradation are required to ensure that the station battery is reliable enough to deliver dc power when required. IEEE Standards 450, 1188, and 1106 for vented lead-acid, valve-regulated lead-acid, and nickel-cadmium batteries, respectively (which are the most commonly used substation batteries on the NERC BES) have been developed as an important reference source of maintenance recommendations. The Protection System owner might want to follow the guidelines in the applicable IEEE recommended practices for battery maintenance and testing, especially if the battery in question is used for application requirements in addition to the protection and control demands covered under this standard. However, the Standard Drafting Team has tailored the battery maintenance and

testing guidelines in PRC-005-4-6 for the Protection System owner which are application specific for the BES Facilities. While the IEEE recommendations are all encompassing, PRC-005-4-6 is a more economical approach while addressing the reliability requirements of the BES.

5. Aggregated small entities might distribute the testing of the population of UFLS/UVLS systems, and large entities will usually maintain a portion of these systems in any given year. Additionally, if relatively small quantities of such systems do not perform properly, it will not affect the integrity of the overall program. Thus, these distributed systems have decreased requirements as compared to other Protection Systems.
6. Voltage and& current sensing device circuit input connections to the Protection System relays can be verified by (but not limited to) comparison of measured values on live circuits or by using test currents and voltages on equipment out of service for maintenance. The verification process can be automated or manual. The values should be verified to be as expected (phase value and phase relationships are both equally important to verify).
7. “End-to-end test,” as used in this Supplementary Reference, is any testing procedure that creates a remote input to the local communications-assisted trip scheme. While this can be interpreted as a GPS-type functional test, it is not limited to testing via GPS. Any remote scheme manipulation that can cause action at the local trip path can be used to functionally-test the dc control circuitry. A documented Real-time trip of any given trip path is acceptable in lieu of a functional trip test. It is possible, with sufficient monitoring, to be able to verify each and every parallel trip path that participated in any given dc control circuit trip. Or another possible solution is that a single trip path from a single monitored relay can be verified to be the trip path that successfully tripped during a Real-time operation. The variations are only limited by the degree of engineering and monitoring that an entity desires to pursue.
8. A/D verification may use relay front panel value displays, or values gathered via data communications. Groupings of other measurements (such as vector summation of bus feeder currents) can be used for comparison if calibration requirements assure acceptable measurement of power system input values.
9. Notes 1-8 attempt to describe some testing activities; they do not represent the only methods to achieve these activities, but rather some possible methods. Technological advances, ingenuity and/or industry accepted techniques can all be used to satisfy maintenance activity requirements; the standard is technology- and method-neutral in most cases.

8.1.3 Frequently Asked Questions:

What is meant by "Verify that settings are as specified" maintenance activity in Table 1-1?

Verification of settings is an activity directed mostly towards microprocessor- based relays. For relay maintenance departments that choose to test microprocessor-based relays in the same manner as electromechanical relays are tested, the testing process sometimes requires that some specific functions be disabled. Later tests might enable the functions previously disabled, but perhaps still other functions or logic statements were then masked out. It is

imperative that, when the relay is placed into service, the settings in the relay be the settings that were intended to be in that relay or as the standard states “...settings are as specified.”

Many of the microprocessor-based relays available today have software tools which provide this functionality and generate reports for this purpose.

For evidence or documentation of this requirement, a simple recorded acknowledgement that the settings were checked to be as specified is sufficient.

The drafting team was careful not to require “...that the relay settings be correct...” because it was believed that this might then place a burden of proof that the specified settings would result in the correct intended operation of the interrupting device. While that is a noble intention, the measurable proof of such a requirement is immense. The intent is that settings of the component be as specified at the conclusion of maintenance activities, whether those settings may have “drifted” since the prior maintenance or whether changes were made as part of the testing process.

Are electromechanical relays included in the "Verify that settings are as specified" maintenance activity in Table 1-1?

Verification of settings is an activity directed towards the application of protection related functions of microprocessor based relays. Electromechanical relays require calibration verification by voltage and/or current injection; and, thus, the settings are verified during calibration activity. In the example of a time-overcurrent relay, a minor deviation in time dial, versus the settings, may be acceptable, as long as the relay calibration is within accepted tolerances at the injected current amplitudes. A major deviation may require further investigation, as it could indicate a problem with the relay or an incorrect relay style for the application.

The verification of phase current and voltage measurements by comparison to other quantities seems reasonable. How, though, can I verify residual or neutral currents, or 3V0 voltages, by comparison, when my system is closely balanced?

Since these inputs are verified at commissioning, maintenance verification requires ensuring that phase quantities are as expected and that 3IO and 3V0 quantities appear equal to or close to 0.

These quantities also may be verified by use of oscillographic records for connected microprocessor relays as recorded during system Disturbances. Such records may compare to similar values recorded at other locations by other microprocessor relays for the same event, or compared to expected values (from short circuit studies) for known Fault locations.

What does this Standard require for testing an auxiliary tripping relay?

Table 1 and Table 3 requires that a trip test must verify that the auxiliary tripping relay(s) and/or lockout relay(s) which are directly in a trip path from the protective relay to the interrupting device trip coil operate(s) electrically. Auxiliary outputs not in a trip path (i.e. annunciation or DME input) are not required, by this standard, to be checked.

Do I have to perform a full end-to-end test of a Remedial Action Schemes?

No. ~~---All~~ all portions of the RAS need to be maintained, and the portions must overlap, but the overall RAS does not need to have a single end-to-end test. In other words it may be tested in piecemeal fashion provided all of the pieces are verified.

What about RAS interfaces between different entities or owners?

As in all of the Protection System requirements, RAS segments can be tested individually, thus minimizing the need to accommodate complex maintenance schedules.

What do I have to do if I am using a phasor measurement unit (PMU) as part of a Protection System or Remedial Action Schemes?

Any Phasor Measurement Unit (PMU) function whose output is used in a Protection System or Remedial Action Schemes (as opposed to a monitoring task) must be verified as a component in a Protection System.

How do I maintain a Remedial Action Schemes or relay sensing for non-distributed UFLS or UVLS Systems?

Since components of the RAS, UFLS and UVLS are the same types of components as those in Protection Systems, then these components should be maintained like similar components used for other Protection System functions. In many cases the devices for RAS, UFLS and UVLS are also used for other protective functions. The same maintenance activities apply with the exception that distributed systems (UFLS and UVLS) have fewer dc supply and control circuitry maintenance activity requirements.

For the testing of the output action, verification may be by breaker tripping, but may be verified in overlapping segments. For example, an RAS that trips a remote circuit breaker might be tested by testing the various parts of the scheme in overlapping segments. Another method is to document the Real-time tripping of an RAS scheme should that occur. Forced trip tests of circuit breakers (etc.) that are a part of distributed UFLS or UVLS schemes are not required.

The established maximum allowable intervals do not align well with the scheduled outages for my power plant. Can I extend the maintenance to the next scheduled outage following the established maximum interval?

No. ~~---y~~ You must complete your maintenance within the established maximum allowable intervals in order to be compliant. You will need to schedule your maintenance during available outages to complete your maintenance as required, even if it means that you may do protective relay maintenance more frequently than the maximum allowable intervals. The maintenance intervals were selected with typical plant outages, among other things, in mind.

If I am unable to complete the maintenance, as required, due to a major natural disaster (hurricane, earthquake, etc.), how will this affect my compliance with this standard?

The Sanction Guidelines of the North American Electric Reliability Corporation, effective January 15, 2008, provides that the Compliance Monitor will consider extenuating circumstances when considering any sanctions.

What if my observed testing results show a high incidence of out-of-tolerance relays; or, even worse, I am experiencing numerous relay Misoperations due to the relays being out-of-tolerance?

The established maximum time intervals are mandatory only as a not-to-exceed limitation. The establishment of a maximum is measurable. But any entity can choose to test some or all of their Protection System components more frequently (or to express it differently, exceed the minimum requirements of the standard). Particularly if you find that the maximum intervals in the standard do not achieve your expected level of performance, it is understandable that you would maintain the related equipment more frequently. A high incidence of relay Misoperations is in no one's best interest.

We believe that the four-month interval between inspections is unnecessary. Why can we not perform these inspections twice per year?

The Standard Drafting Team, through the comment process, has discovered that routine monthly inspections are not the norm. To align routine station inspections with other important inspections, the four-month interval was chosen. In lieu of station visits, many activities can be accomplished with automated monitoring and alarming.

Our maintenance plan calls for us to perform routine protective relay tests every 3 years. If we are unable to achieve this schedule, but we are able to complete the procedures in less than the maximum time interval, then are we in or out of compliance?

According to [Requirement R3](#), if you have a time-based maintenance program, then you will be in violation of the standard only if you exceed the maximum maintenance intervals prescribed in the Tables. According to [Requirement R4](#), if your device in question is part of a Performance-Based Maintenance program, then you will be in violation of the standard if you fail to meet your PSMP, even if you do not exceed the maximum maintenance intervals prescribed in the Tables. The intervals in the Tables are associated with TBM and CBM; Attachment A is associated with PBM.

Please provide a sample list of devices or systems that must be verified in a generator, generator step-up transformer, generator connected station service or generator connected excitation transformer to meet the requirements of this maintenance standard.

Examples of typical devices and systems that may directly trip the generator, or trip through a lockout relay, may include, but are not necessarily limited to:

- Fault protective functions, including distance functions, voltage-restrained overcurrent functions, or voltage-controlled overcurrent functions
- Loss-of-field relays
- Volts-per-hertz relays
- Negative sequence overcurrent relays
- Over voltage and under voltage protection relays
- Stator-ground relays
- Communications-based Protection Systems such as transfer-trip systems
- Generator differential relays

-
- Reverse power relays
 - Frequency relays
 - Out-of-step relays
 - Inadvertent energization protection
 - Breaker failure protection

For generator step-up, generator-connected station service transformers, or generator connected excitation transformers, operation of any of the following associated protective relays frequently would result in a trip of the generating unit; and, as such, would be included in the program:

- Transformer differential relays
- Neutral overcurrent relay
- Phase overcurrent relays

Relays which trip breakers serving station auxiliary Loads such as pumps, fans, or fuel handling equipment, etc., need not be included in the program, even if the loss of the those Loads could result in a trip of the generating unit. Furthermore, relays which provide protection to secondary unit substation (SUS) or low switchgear transformers and relays protecting other downstream plant electrical distribution system components are not included in the scope of this program, even if a trip of these devices might eventually result in a trip of the generating unit. For example, a thermal overcurrent trip on the motor of a coal-conveyor belt could eventually lead to the tripping of the generator, but it does not cause the trip.

In the case where a plant does not have a generator connected station service transformer such that it is normally fed from a system connected station service transformer, is it still the drafting team's intent to exclude the Protection Systems for these system connected auxiliary transformers from scope even when the loss of the normal (system connected) station service transformer will result in a trip of a BES generating Facility?

The SDT does not intend that the system-connected station service transformers be included in the Applicability. The generator-connected station service transformers and generator connected excitation transformers are often connected to the generator bus directly without an interposing breaker; thus, the Protection Systems on these transformers will trip the generator as discussed in 4.2.5.1.

What is meant by "verify operation of the relay inputs and outputs that are essential to proper functioning of the Protection System?"

Any input or output (of the relay) that "affects the tripping" of the breaker is included in the scope of I/O of the relay to be verified. By "affects the tripping," one needs to realize that sometimes there are more inputs and outputs than simply the output to the trip coil. Many important protective functions include things like breaker fail initiation, zone timer initiation and sometimes even 52a/b contact inputs are needed for a protective relay to correctly operate.

Each input should be "picked up" or "turned on and off" and verified as changing state by the microprocessor of the relay. Each output should be "operated" or "closed and opened" from the microprocessor of the relay and the output should be verified to change state on the output

terminals of the relay. One possible method of testing inputs of these relays is to “jumper” the needed dc voltage to the input and verify that the relay registered the change of state.

Electromechanical lock-out relays (86) (used to convey the tripping current to the trip coils) need to be electrically operated to prove the capability of the device to change state. These tests need to be accomplished at least every six years, unless PBM methodology is applied.

The contacts on the 86 or auxiliary tripping relays (94) that change state to pass on the trip current to a breaker trip coil need only be checked every 12 years with the control circuitry.

What is the difference between a distributed UFLS/UVLS and a non-distributed UFLS/UVLS scheme?

A distributed UFLS or UVLS scheme contains individual relays which make independent Load shed decisions based on applied settings and localized voltage and/or current inputs. A distributed scheme may involve an enable/disable contact in the scheme and still be considered a distributed scheme. A non-distributed UFLS or UVLS scheme involves a system where there is some type of centralized measurement and Load shed decision being made. A non-distributed UFLS/UVLS scheme is considered similar to an RAS scheme and falls under Table 1 for maintenance activities and intervals.

8.2 Retention of Records

PRC-005-1 describes a reporting or auditing cycle of one year and retention of records for three years. However, with a three-year retention cycle, the records of verification for a Protection System might be discarded before the next verification, leaving no record of what was done if a Misoperation or failure is to be analyzed.

PRC-005-~~4~~-6 corrects this by requiring:

The Transmission Owner, Generator Owner, and Distribution Provider shall each keep data or evidence to show compliance as identified below unless directed by its Compliance Enforcement Authority to retain specific evidence for a longer period of time as part of an investigation.

~~-For Requirement R1, the Transmission Owner, Generator Owner, and Distribution Provider shall each keep its current dated Protection System Maintenance Program, as well as any superseded versions since the preceding compliance audit, including the documentation that specifies the type of maintenance program applied for each Protection System, Automatic Reclosing, or Sudden Pressure Relaying Component Type.~~

For Requirement R2, Requirement R3, and Requirement R4, in cases where the interval of the maintenance activity is longer than the audit cycle, the Transmission Owner, Generator Owner, and Distribution Provider shall each keep documentation of the most recent performance of that maintenance activity for the Protection System, Automatic Reclosing, or Sudden Pressure Relaying Component. In cases where the interval of the maintenance activity is shorter than the audit cycle, documentation of all performances (in accordance with the tables) of that maintenance activity for the Protection System, Automatic Reclosing, or Sudden Pressure Relaying Component since the previous scheduled audit date shall be retained.

For Requirement R5 the Transmission Owner, Generator Owner, and Distribution Provider shall each keep documentation of Unresolved Maintenance Issues identified by the entity since the last audit, including all that were resolved since the last audit.

This requirement assures that the documentation shows that the interval between maintenance cycles correctly meets the maintenance interval limits. The requirement is actually alerting the industry to documentation requirements already implemented by audit teams. Evidence of compliance bookending the interval shows interval accomplished instead of proving only your planned interval.

The SDT is aware that, in some cases, the retention period could be relatively long. But, the retention of documents simply helps to demonstrate compliance.

8.2.1 Frequently Asked Questions:

Please clarify the data retention requirements.

The data retention requirements are intended to allow the availability of maintenance records to demonstrate that the time intervals in your maintenance plan were upheld.

<u>Maximum Maintenance Interval</u>	<u>Data Retention Period</u>
4 Months, 6 Months, 18 Months, or 3 Years	All activities since previous audit
6 Years	All activities since previous audit (assuming a 6 year audit cycle) or most recent performance (assuming 3 year audit cycle), whichever is longer
12 Year	All activities from the most recent performance

If an entity prefers to utilize Performance-Based Maintenance, then statistical data may ~~well~~ be retained for extended periods to assist with future adjustments in time intervals.

If an equipment item is replaced, then the entity can restart the maintenance-time-interval-clock if desired; however, the replacement of equipment does not remove any documentation requirements that would have been required to verify compliance with time-interval requirements. In other words, do not discard maintenance data that goes to verify your work.

The retention of documentation for new and/or replaced equipment is all about proving that the maintenance intervals had been in compliance. For example, a long-range plan of upgrades might lead an entity to ignore required maintenance; retaining the evidence of prior maintenance that existed before any retirements and upgrades proves compliance with the standard.

What does this Maintenance Standard say about commissioning? Is it necessary to have documentation in your maintenance history of the completion of commission testing?

This standard does not establish requirements for commission testing. Commission testing includes all testing activities necessary to conclude that a Facility has been built in accordance with design. While a thorough commission testing program would include, either directly or indirectly, the verification of all those Protection System attributes addressed by the

maintenance activities specified in the Tables of PRC-005-4-6, verification of the adequacy of initial installation necessitates the performance of testing and inspections that go well beyond these routine maintenance activities. For example, commission testing might set baselines for future tests; perform acceptance tests and/or warranty tests; utilize testing methods that are not generally done routinely like staged-Fault-tests.

However, many of the Protection System attributes which are verified during commission testing are not subject to age related or service related degradation, and need not be re-verified within an ongoing maintenance program. Example— it is not necessary to re-verify correct terminal strip wiring on an ongoing basis.

PRC-005-4-6 assumes that thorough commission testing was performed prior to a Protection System being placed in service. PRC-005-4-6 requires performance of maintenance activities that are deemed necessary to detect and correct plausible age and service related degradation of components, such that a properly built and commission tested Protection System will continue to function as designed over its service life.

It should be noted that commission testing frequently is performed by a different organization than that which is responsible for the ongoing maintenance of the Protection System. Furthermore, the commission testing activities will not necessarily correlate directly with the maintenance activities required by the standard. As such, it is very likely that commission testing records will deviate significantly from maintenance records in both form and content; and, therefore, it is not necessary to maintain commission testing records within the maintenance program documentation.

Notwithstanding the differences in records, an entity would be wise to retain commissioning records to show a maintenance start date. (See below). An entity that requires that their commissioning tests have, at a minimum, the requirements of PRC-005-4-6 would help that entity prove time interval maximums by setting the initial time clock.

How do you determine the initial due date for maintenance?

The initial due date for maintenance should be based upon when a Protection System was tested. Alternatively, an entity may choose to use the date of completion of the commission testing of the Protection System component and the system was placed into service as the starting point in determining its first maintenance due dates. Whichever method is chosen, for newly installed Protection Systems the components should not be placed into service until minimum maintenance activities have taken place.

It is conceivable that there can be a (substantial) difference in time between the date of testing, as compared to the date placed into service. The use of the “Calendar Year” language can help determine the next due date without too much concern about being non-compliant for missing test dates by a small amount (provided your dates are not already at the end of a year). However, if there is a substantial amount of time difference between testing and in-service dates, then the testing date should be followed because it is the degradation of components that is the concern. While accuracy fluctuations may decrease when components are not energized, there are cases when degradation can take place, even though the device is not energized. Minimizing the time between commissioning tests and in-service dates will help.

If I miss two battery inspections four times out of 100 Protection System components on my transmission system, does that count as 2% or 8% when counting Violation Severity Level (VSL) for R3?

The entity failed to complete its scheduled program on two of its 100 Protection System components, which would equate to 2% for application to the VSL Table for Requirement R3. This VSL is written to compare missed components to total components. In this case two components out of 100 were missed, or 2%.

How do I achieve a "grace period" without being out of compliance?

The objective here is to create a time extension within your own PSMP that still does not violate the maximum time intervals stated in the standard. Remember that the maximum time intervals listed in the Tables cannot be extended.

For the purposes of this example, concentrating on just unmonitored protective relays – Table 1-1 specifies a maximum time interval (between the mandated maintenance activities) of six calendar years. Your plan must ensure that your unmonitored relays are tested at least once every six calendar years. You could, within your PSMP, require that your unmonitored relays be tested every four calendar years, with a maximum allowable time extension of 18 calendar months. This allows an entity to have deadlines set for the auto-generation of work orders, but still has the flexibility in scheduling complex work schedules. This also allows for that 18 calendar months to act as a buffer, in effect a grace period within your PSMP, in the event of unforeseen events. You will note that this example of a maintenance plan interval has a planned time of four years; it also has a built-in time extension allowed within the PSMP, and yet does not exceed the maximum time interval allowed by the standard. So while there are no time extensions allowed beyond the standard, an entity can still have substantial flexibility to maintain their Protection System components.

8.3 Basis for Table 1 Intervals

When developing the original *Protection System Maintenance – A Technical Reference* in 2007, the SPCTF collected all available data from Regional Entities (REs) on time intervals recommended for maintenance and test programs. The recommendations vary widely in categorization of relays, defined maintenance actions, and time intervals, precluding development of intervals by averaging. The SPCTF also reviewed the 2005 Report [2] of the IEEE Power System Relaying Committee Working Group I-17 (Transmission Relay System Performance Comparison). Review of the I-17 report shows data from a small number of utilities, with no company identification or means of investigating the significance of particular results.

To develop a solid current base of practice, the SPCTF surveyed its members regarding their maintenance intervals for electromechanical and microprocessor relays, and asked the members to also provide definitively-known data for other entities. The survey represented 470 GW of peak Load, or 4% of the NERC peak Load. Maintenance interval averages were compiled by weighting reported intervals according to the size (based on peak Load) of the reporting utility. Thus, the averages more accurately represent practices for the large populations of Protection Systems used across the NERC regions.

The results of this survey with weighted averaging indicate maintenance intervals of five years for electromechanical or solid state relays, and seven years for unmonitored microprocessor relays.

A number of utilities have extended maintenance intervals for microprocessor relays beyond seven years, based on favorable experience with the particular products they have installed. To provide a technical basis for such extension, the SPCTF authors developed a recommendation of 10 years using the Markov modeling approach from [1], as summarized in Section 8.4. The results of this modeling depend on the completeness of self-testing or monitoring. Accordingly, this extended interval is allowed by Table 1, only when such relays are monitored as specified in the attributes of monitoring contained in Tables 1-1 through 1-5 and Table 2. Monitoring is capable of reporting Protection System health issues that are likely to affect performance within the 10 year time interval between verifications.

It is important to note that, according to modeling results, Protection System availability barely changes as the maintenance interval is varied below the 10-year mark. Thus, reducing the maintenance interval does not improve Protection System availability. With the assumptions of the model regarding how maintenance is carried out, reducing the maintenance interval actually degrades Protection System availability.

8.4 Basis for Extended Maintenance Intervals for Microprocessor Relays

Table 1 allows maximum verification intervals that are extended based on monitoring level. The industry has experience with self-monitoring microprocessor relays that leads to the Table 1 value for a monitored relay, as explained in Section 8.3. To develop a basis for the maximum interval for monitored relays in their *Protection System Maintenance – A Technical Reference*, the SPCTF used the methodology of Reference [1], which specifically addresses optimum routine maintenance intervals. The Markov modeling approach of [1] is judged to be valid for the design and typical failure modes of microprocessor relays.

The SPCTF authors ran test cases of the Markov model to calculate two key probability measures:

- Relay Unavailability - the probability that the relay is out of service due to failure or maintenance activity while the power system Element to be protected is in service.
- Abnormal Unavailability - the probability that the relay is out of service due to failure or maintenance activity when a Fault occurs, leading to failure to operate for the Fault.

The parameter in the Markov model that defines self-monitoring capability is ST (for self-test). ST = 0 if there is no self-monitoring; ST = 1 for full monitoring. Practical ST values are estimated to range from .75 to .95. The SPCTF simulation runs used constants in the Markov model that were the same as those used in [1] with the following exceptions:

Sn, Normal tripping operations per hour = 21600 (reciprocal of normal Fault clearing time of 10 cycles)

Sb, Backup tripping operations per hour = 4320 (reciprocal of backup Fault clearing time of 50 cycles)

Rc, Protected component repairs per hour = 0.125 (8 hours to restore the power system)

Rt, Relay routine tests per hour = 0.125 (8 hours to test a Protection System)

Rr, Relay repairs per hour = 0.08333 (12 hours to complete a Protection System repair after failure)

Experimental runs of the model showed low sensitivity of optimum maintenance interval to

these parameter adjustments.

The resulting curves for relay unavailability and abnormal unavailability versus maintenance interval showed a broad minimum (optimum maintenance interval) in the vicinity of 10 years – the curve is flat, with no significant change in either unavailability value over the range of 9, 10, or 11 years. This was true even for a relay mean time between Failures (MTBF) of 50 years, much lower than MTBF values typically published for these relays. Also, the Markov modeling indicates that both the relay unavailability and abnormal unavailability actually become higher with more frequent testing. This shows that the time spent on these more frequent tests yields no failure discoveries that approach the negative impact of removing the relays from service and running the tests.

The PSMT SDT discussed the practical need for “time-interval extensions” or “grace periods” to allow for scheduling problems that resulted from any number of business contingencies. The time interval discussions also focused on the need to reflect industry norms surrounding Generator outage frequencies. Finally, it was again noted that FERC Order 693 demanded maximum time intervals. “Maximum time intervals” by their very term negates any “time-interval extension” or “grace periods.” To recognize the need to follow industry norms on Generator outage frequencies and accommodate a form of time-interval extension, while still following FERC Order 693, the Standard Drafting Team arrived at a six-year interval for the electromechanical relay, instead of the five-year interval arrived at by the SPCTF. The PSMT SDT has followed the FERC directive for a *maximum* time interval and has determined that no extensions will be allowed. Six years has been set for the maximum time interval between manual maintenance activities. This maximum time interval also works well for maintenance cycles that have been in use in generator plants for decades.

For monitored relays, the PSMT SDT notes that the SPCTF called for 10 years as the interval between maintenance activities. This 10-year interval was chosen, even though there was “...no significant change in unavailability value over the range of 9, 10, or 11 years. This was true even for a relay Mean Time between Failures (MTBF) of 50 years...” The Standard Drafting Team again sought to align maintenance activities with known successful practices and outage schedules. The Standard does not allow extensions on any component of the Protection System; thus, the maximum allowed interval for these components has been set to 12 years. Twelve years also fits well into the traditional maintenance cycles of both substations and generator plants.

Also of note is the Table’s use of the term “Calendar” in the column for “Maximum Maintenance Interval.” The PSMT SDT deemed it necessary to include the term “Calendar” to facilitate annual maintenance planning, scheduling and implementation. This need is the result of known occurrences of system requirements that could cause maintenance schedules to be missed by a few days or weeks. The PSMT SDT chose the term “Calendar” to preclude the need to have schedules be met to the day. An electromechanical protective relay that is maintained in year number one need not be revisited until six years later (year number seven). For example, a relay was maintained April 10, 2008; maintenance would need to be completed no later than December 31, 2014.

Though not a requirement of this standard, to stay in line with many Compliance Enforcement Agencies audit processes an entity should define, within their own PSMP, the entity’s use of terms like annual, calendar year, etc. Then, once this is within the PSMP, the entity should abide by their chosen language.

9. Performance-Based Maintenance Process

In lieu of using the Table 1 intervals, a Performance-Based Maintenance process may be used to establish maintenance intervals (*PRC-005 Attachment A Criteria for a Performance-Based Protection System Maintenance Program*). A Performance-Based Maintenance process may justify longer maintenance intervals, or require shorter intervals relative to Table 1. In order to use a Performance-Based Maintenance process, the documented maintenance program must include records of repairs, adjustments, and corrections to covered Protection Systems in order to provide historical justification for intervals, other than those established in Table 1. Furthermore, the asset owner must regularly analyze these records of corrective actions to develop a ranking of causes. Recurrent problems are to be highlighted, and remedial action plans are to be documented to mitigate or eliminate recurrent problems.

Entities with Performance-Based Maintenance track performance of Protection Systems, demonstrate how they analyze findings of performance failures and aberrations, and implement continuous improvement actions. Since no maintenance program can ever guarantee that no malfunction can possibly occur, documentation of a Performance-Based Maintenance program would serve the utility well in explaining to regulators and the public a Misoperation leading to a major System outage event.

A Performance-Based Maintenance program requires auditing processes like those included in widely used industrial quality systems (such as *ISO 9001-2000, Quality Management Systems – Requirements*; or applicable parts of the NIST Baldrige National Quality Program). The audits periodically evaluate:

- The completeness of the documented maintenance process
- Organizational knowledge of and adherence to the process
- Performance metrics and documentation of results
- Remediation of issues
- Demonstration of continuous improvement.

In order to opt into a Performance-Based Maintenance (PBM) program, the asset owner must first sort the various Components into population segments. Any population segment must be comprised of at least 60 individual units; if any asset owner opts for PBM, but does not own 60 units to comprise a population, then that asset owner may combine data from other asset owners until the needed 60 units is aggregated. Each population segment must be composed of a grouping of Components of a consistent design standard or particular model or type from a single manufacturer and subjected to similar environmental factors. For example: One segment cannot be comprised of both GE & Westinghouse electro-mechanical lock-out relays; likewise, one segment cannot be comprised of 60 GE lock-out relays, 30 of which are in a dirty environment, and the remaining 30 from a clean environment. This PBM process cannot be applied to batteries, but can be applied to all other Components, including (but not limited to) specific battery chargers, instrument transformers, trip coils and/or control circuitry (etc.).

9.1 Minimum Sample Size

Large Sample Size

An assumption that needs to be made when choosing a sample size is “the sampling distribution of the sample mean can be approximated by a normal probability distribution.” The Central Limit Theorem states: “In selecting simple random samples of size n from a population, the sampling distribution of the sample mean \bar{x} can be approximated by a normal probability distribution as the sample size becomes large.” (Essentials of Statistics for Business and Economics, Anderson, Sweeney, Williams, 2003.)

To use the Central Limit Theorem in statistics, the population size should be large. The references below are supplied to help define what is large.

“... whenever we are using a large simple random sample (rule of thumb: $n \geq 30$), the central limit theorem enables us to conclude that the sampling distribution of the sample mean can be approximated by a normal distribution.” (Essentials of Statistics for Business and Economics, Anderson, Sweeney, Williams, 2003.)

“If samples of size n , when $n \geq 30$, are drawn from any population with a mean μ and a standard deviation σ , the sampling distribution of sample means approximates a normal distribution. The greater the sample size, the better the approximation.” (Elementary Statistics - Picturing the World, Larson, Farber, 2003.)

“The sample size is large (generally $n \geq 30$)... (Introduction to Statistics and Data Analysis - Second Edition, Peck, Olson, Devore, 2005.)

“... the normal is often used as an approximation to the t distribution in a test of a null hypothesis about the mean of a normally distributed population when the population variance is estimated from a relatively large sample. A sample size exceeding 30 is often given as a minimal size in this connection.” (Statistical Analysis for Business Decisions, Peters, Summers, 1968.)

Error of Distribution Formula

Beyond the large sample size discussion above, a sample size requirement can be estimated using the bound on the Error of Distribution Formula when the expected result is of a “Pass/Fail” format and will be between 0 and 1.0.

The Error of Distribution Formula is:

$$B = z \sqrt{\frac{\pi(1-\pi)}{n}}$$

Where:

B = bound on the error of distribution (allowable error)

z = standard error

π = expected failure rate

n = sample size required

Solving for n provides:

$$n = \pi(1 - \pi) \left(\frac{z}{B} \right)^2$$

Minimum Population Size to use Performance-Based Program

One entity's population of components should be large enough to represent a sizeable sample of a vendor's overall population of manufactured devices. For this reason, the following assumptions are made:

$$B = 5\%$$

$$z = 1.96 \text{ (This equates to a 95\% confidence level)}$$

$$\pi = 4\%$$

Using the equation above, n=59.0.

Minimum Sample Size to evaluate Performance-Based Program

The number of components that should be included in a sample size for evaluation of the appropriate testing interval can be smaller because a lower confidence level is acceptable since the sample testing is repeated or updated annually. For this reason, the following assumptions are made:

$$B = 5\%$$

$$z = 1.44 \text{ (85\% confidence level)}$$

$$\pi = 4\%$$

Using the equation above, n=31.8.

Recommendation

Based on the above discussion, a sample size should be at least 30 to allow use of the equation mentioned. Using this and the results of the equation, the following numbers are recommended (and required within the standard):

Minimum Population Size to use Performance-Based Maintenance Program = 60

Minimum Sample Size to evaluate Performance-Based Program = 30.

Once the population segment is defined, then maintenance must begin within the intervals as outlined for the device described in the Tables 1-1 through 1-5. Time intervals can be lengthened provided the last year's worth of components tested (or the last 30 units maintained, whichever is more) had fewer than 4% Countable Events. It is notable that 4% is specifically chosen because an entity with a small population (30 units) would have to adjust its time intervals between maintenance if more than one Countable Event was found to have occurred during the last analysis period. A smaller percentage would require that entity to adjust the time interval between maintenance activities if even one unit is found out of tolerance or causes a Misoperation.

The minimum number of units that can be tested in any given year is 5% of the population. Note that this 5% threshold sets a practical limitation on total length of time between intervals at 20 years.

If at any time the number of Countable Events equals or exceeds 4% of the last year's tested components (or the last 30 units maintained, whichever is more), then the time period between manual maintenance activities must be decreased. There is a time limit on reaching the decreased time at which the Countable Events is less than 4%; this must be attained within three years.

Performance-Based Program Evaluation Example

The 4% performance target was derived as a protection system performance target and was selected based on the drafting team's experience and studies performed by several utilities. This is not derived from the performance of discrete devices. Microprocessor relays and electromechanical relays have different performance levels. It is not appropriate to compare these performance levels to each other. The performance of the segment should be compared to the 4% performance criteria.

In consideration of the use of Performance Based Maintenance (PBM), the user should consider the effects of extended testing intervals and the established 4% failure rate. In the table shown below, the segment is 1000 units. As the testing interval (in years) increases, the number of units tested each year decreases. The number of countable events allowed is 4% of the tested units. Countable events are the failure of a Component requiring repair or replacement, any corrective actions performed during the maintenance test on the units within the testing segment (units per year), or any misoperation attributable to hardware failure or calibration failure found within the entire segment (1000 units) during the testing year.

Example: 1000 units in the segment with a testing interval of 8 years: The number of units tested each year will be 125 units. The total allowable countable events equals: $125 \times .04 = 5$. This number includes failure of a Component requiring repair or replacement, corrective issues found during testing, and the total number of misoperations (attributable to hardware or calibration failure within the testing year) associated with the entire segment of 1000 units.

Example: 1000 units in the segment with a testing interval of 16 years: The number of units tested each year will be 63 units. The total allowable countable events equals: $63 \times .04 = 2.5$.

As shown in the above examples, doubling the testing interval reduces the number of allowable events by half.

Total number of units in the segment	1000
Failure rate	4.00%

Testing Intervals (Years)	Units Per Year	Acceptable Number of Countable Events per year	Yearly Failure Rate Based on 1000 Units in Segment
1	1000.00	40.00	4.00%
2	500.00	20.00	2.00%
4	250.00	10.00	1.00%
6	166.67	6.67	0.67%
8	125.00	5.00	0.50%
10	100.00	4.00	0.40%
12	83.33	3.33	0.33%
14	71.43	2.86	0.29%
16	62.50	2.50	0.25%
18	55.56	2.22	0.22%
20	50.00	2.00	0.20%

Using the prior year’s data, determine the maximum allowable maintenance interval for each Segment such that the Segment experiences Countable Events on no more than 4% of the Components within the Segment, for the greater of either the last 30 Components maintained or all Components maintained in the previous year.

Segment – Components of a consistent design standard, or a particular model or type from a single manufacturer that typically share other common elements. Consistent performance is expected across the entire population of a Segment. A Segment must contain at least sixty (60) individual Components.

Countable Event – A failure of a Component requiring repair or replacement, any condition discovered during the maintenance activities in Tables 1-1 through 1-5, Table 3, Table 4-1 through Table 4-~~32~~, and Table 5, which requires corrective action or a Protection System Misoperation attributed to hardware failure or calibration failure. Misoperations due to product design errors, software errors, relay settings different from specified settings, Protection System Component, Automatic Reclosing, or Sudden Pressure Relaying configuration or application errors are not included in Countable Events.

9.2 Frequently Asked Questions:

I’m a small entity and cannot aggregate a population of Protection System components to establish a segment required for a Performance-Based Protection System Maintenance Program. How can I utilize that opportunity?

Multiple asset owning entities may aggregate their individually owned populations of individual Protection System components to create a segment that crosses ownership boundaries. All entities participating in a joint program should have a single documented joint management process, with consistent Protection System Maintenance Programs (practices, maintenance

intervals and criteria), for which the multiple owners are individually responsible with respect to the requirements of the Standard. The requirements established for Performance-Based Maintenance must be met for the overall aggregated program on an ongoing basis.

The aggregated population should reflect all factors that affect consistent performance across the population, including any relevant environmental factors such as geography, power-plant vs. substation, and weather conditions.

Can an owner go straight to a Performance-Based Maintenance program schedule, if they have previously gathered records?

Yes. ~~A~~An owner can go to a Performance-Based Maintenance program immediately. The owner will need to comply with the requirements of a Performance-Based Maintenance program as listed in the Standard. Gaps in the data collected will not be allowed; therefore, if an owner finds that a gap exists such that they cannot prove that they have collected the data as required for a Performance-Based Maintenance program then they will need to wait until they can prove compliance.

When establishing a Performance-Based Maintenance program, can I use test data from the device manufacturer, or industry survey results, as results to help establish a basis for my Performance-Based intervals?

No. ~~r~~o you must use actual in-service test data for the components in the segment.

What types of Misoperations or events are not considered Countable Events in the Performance-Based Protection System Maintenance (PBM) Program?

Countable Events are intended to address conditions that are attributed to hardware failure or calibration failure; that is, conditions that reflect deteriorating performance of the component. These conditions include any condition where the device previously worked properly, then, due to changes within the device, malfunctioned or degraded to the point that re-calibration (to within the entity's tolerance) was required.

For this purpose of tracking hardware issues, human errors resulting in Protection System Misoperations during system installation or maintenance activities are not considered Countable Events. Examples of excluded human errors include relay setting errors, design errors, wiring errors, inadvertent tripping of devices during testing or installation, and misapplication of Protection System components. Examples of misapplication of Protection System components include wrong CT or PT tap position, protective relay function misapplication, and components not specified correctly for their installation. Obviously, if one is setting up relevant data about hardware failures then human failures should be eliminated from the hardware performance analysis.

One example of human-error is not pertinent data might be in the area of testing "86" lock-out relays (LOR). "Entity A" has two types of LOR's type "X" and type "Y"; they want to move into a performance based maintenance interval. They have 1000 of each type, so the population variables are met. During electrical trip testing of all of their various schemes over the initial six-year interval they find zero type "X" failures, but human error led to tripping a BES Element 100 times; they find 100 type "Y" failures and had an additional 100 human-error caused tripping incidents. In this example the human-error caused Misoperations should not be used to judge the performance of either type of LOR. Analysis of the data might lead "Entity A" to change time intervals. Type "X" LOR can be placed into extended time interval testing because of its low failure

rate (zero failures) while Type “Y” would have to be tested more often than every 6 calendar years (100 failures divided by 1000 units exceeds the 4% tolerance level).

Certain types of Protection System component errors that cause Misoperations are not considered Countable Events. Examples of excluded component errors include device malfunctions that are correctable by firmware upgrades and design errors that do not impact protection function.

What are some examples of methods of correcting segment performance for Performance-Based Maintenance?

There are a number of methods that may be useful for correcting segment performance for mal-performing segments in a Performance-Based Maintenance system. Some examples are listed below.

- The maximum allowable interval, as established by the Performance-Based Maintenance system, can be decreased. This may, however, be slow to correct the performance of the segment.
- Identifiable sub-groups of components within the established segment, which have been identified to be the mal-performing portion of the segment, can be broken out as an independent segment for target action. Each resulting segment must satisfy the minimum population requirements for a Performance-Based Maintenance program in order to remain within the program.
- Targeted corrective actions can be taken to correct frequently occurring problems. An example would be replacement of capacitors within electromechanical distance relays if bad capacitors were determined to be the cause of the mal-performance.
- Components ~~components~~ within the mal-performing segment can be replaced with other components (electromechanical distance relays with microprocessor relays, for example) to remove the mal-performing segment.

If I find (and correct) a Unresolved Maintenance Issue as a result of a Misoperation investigation (Re: PRC-004), how does this affect my Performance-Based Maintenance program?

If you perform maintenance on a Protection System component for any reason (including as part of a PRC-004 required Misoperation investigation/corrective action), the actions performed can count as a maintenance activity provided the activities in the relevant Tables have been done, and, if you desire, “reset the clock” on everything you’ve done. In a Performance-Based Maintenance program, you also need to record the Unresolved Maintenance Issue as a Countable Event within the relevant component group segment and use it in the analysis to determine your correct Performance-Based Maintenance interval for that component group. Note that “resetting the clock” should not be construed as interfering with an entity’s routine testing schedule because the “clock-reset” would actually make for a decreased time interval by the time the next routine test schedule comes around.

For example, a relay scheme, consisting of four relays, is tested on 1-1-11 and the PSMP has a time interval of 3 calendar years with an allowable extension of 1 calendar year. The relay would be due again for routine testing before the end of the year 2015. This mythical-hypothetical relay scheme has a Misoperation on 6-1-12 that points to one of the four relays as bad. Investigation proves a bad relay and a new one is tested and installed in place of the original. This replacement

relay actually could be retested before the end of the year 2016 (clock-reset) and not be out of compliance. This requires tracking maintenance by individual relays and is allowed. However, many companies schedule maintenance in other ways like by substation or by circuit breaker or by relay scheme. By these methods of tracking maintenance that “replaced relay” will be retested before the end of the year 2015. This is also acceptable. In no case was a particular relay tested beyond the PSMP of four years max, nor was the 6 year max of the Standard exceeded. The entity can reset the clock if they desire or the entity can continue with original schedules and, in effect, test even more frequently.

Why are batteries excluded from PBM? What about exclusion of batteries from condition based maintenance?

Batteries are the only element of a Protection System that is a perishable item with a shelf life. As a perishable item batteries require not only a constant float charge to maintain their freshness (charge), but periodic inspection to determine if there are problems associated with their aging process and testing to see if they are maintaining a charge or can still deliver their rated output as required.

Besides being perishable, a second unique feature of a battery that is unlike any other Protection System element, is that a battery uses chemicals, metal alloys, plastics, welds, and bonds that must interact with each other to produce the constant dc source required for Protection Systems, undisturbed by ac system Disturbances.

No type of battery manufactured today for Protection System application is free from problems of the sort that can only be detected over time by inspection and test. These problems can arise from variances in the manufacturing process, chemicals and alloys used in the construction of the individual cells, quality of welds and bonds to connect the components, the plastics used to make batteries, and the cell forming process for the individual battery cells.

Other problems that require periodic inspection and testing can result from transportation from the factory to the job site, length of time before a charge is put on the battery, the method of installation, the voltage level and duration of equalize charges, the float voltage level used, and the environment that the battery is installed in.

All of the above mentioned factors, and as well as several more not discussed here, are beyond the control of the Functional Entities that want to use a Performance-Based Protection System Maintenance (PBM) program. ~~These~~ inherent variances in the aging process of a battery cell make establishment of a designated segment based on manufacturer and type of battery impossible.

The whole point of PBM is that if all variables are isolated then common aging and performance criteria would be the same. However, there are too many variables in the electrochemical process to completely isolate all of the performance-changing criteria.

Similarly, Functional Entities that want to establish a condition-based maintenance program using the highest levels of monitoring, resulting in the least amount of hands-on maintenance activity, cannot completely eliminate some periodic maintenance of the battery used in a station dc supply. Inspection of the battery is required on a Maximum Maintenance Interval listed in the tables due to the aging processes of station batteries. However, higher degrees of

monitoring of a battery can eliminate the requirement for some periodic testing and some inspections (see Table 1-4).

Please provide an example of the calculations involved in extending maintenance time intervals using PBM.

Entity has 1000 GE-HEA lock-out relays; this is greater than the minimum sample requirement of 60. They start out testing all of the relays within the prescribed Table requirements (6 year max) by testing the relays every 5 years. The entity's plan is to test 200 units per year; this is greater than the minimum sample size requirement of 30. For the sake of example only the following will show 6 failures per year, reality may well have different numbers of failures every year. PBM requires annual assessment of failures found per units tested. After the first year of tests the entity finds 6 failures in the 200 units tested. $6/200 = 3\%$ failure rate. This entity is now allowed to extend the maintenance interval if they choose. The entity chooses to extend the maintenance interval of this population segment out to 10 years. This represents a rate of 100 units tested per year; entity selects 100 units to be tested in the following year. After that year of testing these 100 units the entity again finds 6 failed units. $6/100 = 6\%$ failures. This entity has now exceeded the acceptable failure rate for these devices and must accelerate testing of all of the units at a higher rate such that the failure rate is found to be less than 4% per year; the entity has three years to get this failure rate down to 4% or less (per year). In response to the 6% failure rate, the entity decreases the testing interval to 8 years. This means that they will now test 125 units per year ($1000/8$). The entity has just two years left to get the test rate corrected.

After a year, they again find six failures out of the 125 units tested. $6/125 = 5\%$ failures. In response to the 5% failure rate, the entity decreases the testing interval to seven years. This means that they will now test 143 units per year ($1000/7$). The entity has just one year left to get the test rate corrected. After a year, they again find six failures out of the 143 units tested. $6/143 = 4.2\%$ failures.

(Note that the entity has tried five years and they were under the 4% limit and they tried seven years and they were over the 4% limit. They must be back at 4% failures or less in the next year so they might simply elect to go back to five years.)

Instead, in response to the 5% failure rate, the entity decreases the testing interval to six years. This means that they will now test 167 units per year ($1000/6$). After a year, they again find six failures out of the 167 units tested. $6/167 = 3.6\%$ failures. Entity found that they could maintain the failure rate at no more than 4% failures by maintaining the testing interval at six years or less. Entity chose six-year interval and effectively extended their TBM (five years) program by 20%.

A note of practicality is that an entity will probably be in better shape to lengthen the intervals between tests if the failure rate is less than 2%. But the requirements allow for annual adjustments, if the entity desires. As a matter of maintenance management, an ever-changing test rate (units tested/year) may be un-workable.

Note that the "5% of components" requirement effectively sets a practical limit of 20 year maximum PBM interval. Also of note is the "3 years" requirement; an entity might arbitrarily extend time intervals from six years to 20 years. In the event that an entity finds a failure rate greater than 4%, then the test rate must be accelerated such that within three years the failure rate must be brought back down to 4% or less.

Here is a table that demonstrates the values discussed:

Year #	Total Population (P)	Test Interval (I)	Units to be Tested (U= P/I)	# of Failures Found (F)	Failure Rate (=F/U)	Decision to Change Interval Yes or No	Interval Chosen
1	1000	5 yrs	200	6	3%	Yes	10 yrs
2	1000	10 yrs	100	6	6%	Yes	8 yrs
3	1000	8 yrs	125	6	5%	Yes	7 yrs
4	1000	7 yrs	143	6	4.2%	Yes	6 yrs
5	1000	6 yrs	167	6	3.6%	No	6 yrs

Please provide an example of the calculations involved in extending maintenance time intervals using PBM for control circuitry.

Note that the following example captures “Control Circuitry” as all of the trip paths associated with a particular trip coil of a circuit breaker. An entity is not restricted to this method of counting control circuits. Perhaps another method an entity would prefer would be to simply track every individual (parallel) trip path. Or perhaps another method would be to track all of the trip outputs from a specific (set) of relays protecting a specific element.

The designation of what constitutes a control circuit component is very dependent upon how an entity performs and tracks the testing of the control circuitry. Some entities test their control circuits on a breaker basis whereas others test their circuitry on a local zone of protection basis. Thus, entities are allowed the latitude to designate their own definitions of control circuit components. Another example of where the entity has some discretion on determining what constitutes a single component is the voltage and current sensing devices, where the entity may choose either to designate a full three-phase set of such devices or a single device as a single component.

~~And in~~ Attachment A (PBM) the definition of Segment is:

Segment –*Components of a consistent design standard, or a particular model or type from a single manufacturer that typically share other common elements. Consistent performance is expected across the entire population of a segment. A segment must contain at least sixty (60) individual components.*

Example:

Entity has 1,000 circuit breakers, all of which have two trip coils, for a total of 2,000 trip coils; if all circuitry was designed and built with a consistent (internal entity) standard, then this is greater than the minimum sample requirement of 60.

For the sake of further example, the following facts are given:

Half of all relay panels (500) were built 40 years ago by an outside contractor, consisted of asbestos wrapped 600V-insulation panel wiring, and the cables exiting the control house are THHN pulled in conduit direct to exactly half of all of the various circuit breakers. All of the relay panels and cable pulls were built with consistent standards and consistent performance standard expectations within the segment (which is greater than 60). Each relay panel has redundant microprocessor (MPC) relays (retrofitted); each MPC relay supplies an individual trip output to each of the two trip coils of the assigned circuit breaker.

Approximately 35 years ago, the entity developed their own internal construction crew and now builds all of their own relay panels from parts supplied from vendors that meet the entity’s specifications, including SIS 600V insulation wiring and copper-sheathed cabling within the direct conduits to circuit breakers. The construction crew uses consistent standards in the construction. This newer segment of their control circuitry population is different than the original segment, consistent (standards, construction and performance expectations) within the new segment and constitutes the remainder of the entity’s population (another 500 panels and the cabling to the remaining 500 circuit breakers). Each relay panel has redundant microprocessor (MPC) relays; each MPC relay supplies an individual trip output to each of the two trip coils of the assigned circuit breaker. Every trip path in this newer segment has a device that monitors the voltage directly across the trip contacts of the MPC relays and alarms via RTU and SCADA to the

operations control room. This monitoring device, when not in alarm, demonstrates continuity all the way through the trip coil, cabling and wiring back to the trip contacts of the MPC relay.

The entity is tracking 2,000 trip coils (each consisting of multiple trip paths) in each of these two segments. But half of all of the trip paths are monitored; therefore, the trip paths are continuously tested and the circuit will alarm when there is a failure. These alarms have to be verified every 12 years for correct operation.

The entity now has 1,000 trip coils (and associated trip paths) remaining that they have elected to count as control circuits. The entity has instituted a process that requires the verification of every trip path to each trip coil (one unit), including the electrical activation of the trip coil. (The entity notes that the trip coils will have to be tripped electrically more often than the trip path verification, and is taking care of this activity through other documentation of Real-time Fault operations.)

They start out testing all of the trip coil circuits within the prescribed Table requirements (12-year max) by testing the trip circuits every 10 years. The entity's plan is to test 100 units per year; this is greater than the minimum sample size requirement of 30. For the sake of example only, the following will show three failures per year; reality may well have different numbers of failures every year. PBM requires annual assessment of failures found per units tested. After the first year of tests, the entity finds three failures in the 100 units tested. $3/100 = 3\%$ failure rate.

This entity is now allowed to extend the maintenance interval, if they choose. The entity chooses to extend the maintenance interval of this population segment out to 20 years. This represents a rate of 50 units tested per year; entity selects 50 units to be tested in the following year. After that year of testing these 50 units, the entity again finds three failed units. $3/50 = 6\%$ failures.

This entity has now exceeded the acceptable failure rate for these devices and must accelerate testing of all of the units at a higher rate, such that the failure rate is found to be less than 4% per year; the entity has three years to get this failure rate down to 4% or less (per year).

In response to the 6% failure rate, the entity decreases the testing interval to 16 years. This means that they will now test 63 units per year ($1000/16$). The entity has just two years left to get the test rate corrected. After a year, they again find three failures out of the 63 units tested. $3/63 = 4.76\%$ failures.

In response to the >4% failure rate, the entity decreases the testing interval to 14 years. This means that they will now test 72 units per year ($1000/14$). The entity has just one year left to get the test rate corrected. After a year, they again find three failures out of the 72 units tested. $3/72 = 4.2\%$ failures.

(Note that the entity has tried 10 years, and they were under the 4% limit; and they tried 14 years, and they were over the 4% limit. They must be back at 4% failures or less in the next year, so they might simply elect to go back to 10 years.)

Instead, in response to the 4.2% failure rate, the entity decreases the testing interval to 12 years. This means that they will now test 84 units per year ($1000/12$). After a year, they again find three failures out of the 84 units tested. $3/84 = 3.6\%$ failures.

Entity found that they could maintain the failure rate at no more than 4% failures by maintaining the testing interval at 12 years or less. Entity chose 12-year interval, and effectively extended their TBM (10 years) program by 20%.

A note of practicality is that an entity will probably be in better shape to lengthen the intervals between tests if the failure rate is less than 2%. But the requirements allow for annual adjustments if the entity desires. As a matter of maintenance management, an ever-changing test rate (units tested / year) may be un-workable.

Note that the “5% of components” requirement effectively sets a practical limit of 20-year maximum PBM interval. Also of note is the “3 years” requirement; an entity might arbitrarily extend time intervals from six years to 20 years. In the event that an entity finds a failure rate greater than 4%, then the test rate must be accelerated such that within three years the failure rate must be brought back down to 4% or less.

Here is a table that demonstrates the values discussed:

Year #	Total Population (P)	Test Interval (I)	Units to be Tested (U= P/I)	# of Failures Found (F)	Failure Rate (=F/U)	Decision to Change Interval Yes or No	Interval Chosen
1	1000	10 yrs	100	3	3%	Yes	20 yrs
2	1000	20 yrs	50	3	6%	Yes	16yrs
3	1000	16 yrs	63	3	4.8%	Yes	14 yrs
4	1000	14 yrs	72	3	4.2%	Yes	12 yrs
5	1000	12 yrs	84	3	3.6%	No	12 yrs

Please provide an example of the calculations involved in extending maintenance time intervals using PBM for voltage and current sensing devices.

Note that the following example captures “voltage and current inputs to the protective relays” as all of the various current transformer and potential transformer signals associated with a particular set of relays used for protection of a specific Element. This entity calls this set of protective relays a “Relay Scheme.” Thus, this entity chooses to count PT and CT signals as a group instead of individually tracking maintenance activities to specific bushing CT’s or specific PT’s. An entity is not restricted to this method of counting voltage and current devices, signals and paths. Perhaps another method an entity would prefer would be to simply track every individual PT and CT. Note that a generation maintenance group may well select the latter because they may elect to perform routine off-line tests during generator outages, whereas a transmission maintenance group might create a process that utilizes Real-time system values measured at the relays.

The designation of what constitutes a control circuit component is very dependent upon how an entity performs and tracks the testing of the control circuitry. Some entities test their control circuits on a breaker basis whereas others test their circuitry on a local zone of protection basis. Thus, entities are allowed the latitude to designate their own definitions of control circuit components. Another example of where the entity has some discretion on determining what constitutes a single component is the voltage and current sensing devices, where the entity may choose either to designate a full three-phase set of such devices or a single device as a single component.

And in Attachment A (PBM) the definition of Segment:

Segment –*Components of a consistent design standard, or a particular model or type from a single manufacturer that typically share other common elements. Consistent performance is expected across the entire population of a segment. A segment must contain at least sixty (60) individual components.*

Example:

Entity has 2000 “Relay Schemes,” all of which have three current signals supplied from bushing CTs, and three voltage signals supplied from substation bus PT’s. All cabling and circuitry was designed and built with a consistent (internal entity) standard, and this population is greater than the minimum sample requirement of 60.

For the sake of further example the following facts are given:

Half of all relay schemes (1,000) are supplied with current signals from ANSI STD C800 bushing CTs and voltage signals from PTs built by ACME Electric MFR CO. All of the relay panels and cable pulls were built with consistent standards, and consistent performance standard expectations exist for the consistent wiring, cabling and instrument transformers within the segment (which is greater than 60).

The other half of the entity’s relay schemes have MPC relays with additional monitoring built-in that compare DNP values of voltages and currents (or Watts and VARs), as interpreted by the MPC relays and alarm for an entity-accepted tolerance level of accuracy. This newer segment of their “Voltage and Current Sensing” population is different than the original segment, consistent

(standards, construction and performance expectations) within the new segment and constitutes the remainder of the entity's population.

The entity is tracking many thousands of voltage and current signals within 2,000 relay schemes (each consisting of multiple voltage and current signals) in each of these two segments. But half of all of the relay schemes voltage and current signals are monitored; therefore, the voltage and current signals are continuously tested and the circuit will alarm when there is a failure; these alarms have to be verified every 12 years for correct operation.

The entity now has 1,000 relay schemes worth of voltage and current signals remaining that they have elected to count within their relay schemes designation. The entity has instituted a process that requires the verification of these voltage and current signals within each relay scheme (one unit).

(Please note - a problem discovered with a current or voltage signal found at the relay could be caused by anything from the relay, all the way to the signal source itself. Having many sources of problems can easily increase failure rates beyond the rate of failures of just one item (for example just PTs). It is the intent of the SDT to minimize failure rates of all of the equipment to an acceptable level; thus, any failure of any item that gets the signal from source to relay is counted. It is for this reason that the SDT chose to set the boundary at the ability of the signal to be delivered all the way to the relay.

The entity will start out measuring all of the relay scheme voltage and currents at the individual relays within the prescribed Table requirements (12 year max) by measuring the voltage and current values every 10 years. The entity's plan is to test 100 units per year; this is greater than the minimum sample size requirement of 30. For the sake of example only, the following will show three failures per year; reality may well have different numbers of failures every year. PBM requires annual assessment of failures found per units tested. After the first year of tests, the entity finds three failures in the 100 units tested. $3/100 = 3\%$ failure rate.

This entity is now allowed to extend the maintenance interval, if they choose. The entity chooses to extend the maintenance interval of this population segment out to 20 years. This represents a rate of 50 units tested per year; entity selects 50 units to be tested in the following year. After that year of testing these 50 units, the entity again finds three failed units. $3/50 = 6\%$ failures.

This entity has now exceeded the acceptable failure rate for these devices and must accelerate testing of all of the units at a higher rate, such that the failure rate is found to be less than 4% per year; the entity has three years to get this failure rate down to 4% or less (per year).

In response to the 6% failure rate, the entity decreases the testing interval to 16 years. This means that they will now test 63 units per year ($1000/16$). The entity has just two years left to get the test rate corrected. After a year, they again find three failures out of the 63 units tested. $3/63 = 4.76\%$ failures.

In response to the >4% failure rate, the entity decreases the testing interval to 14 years. This means that they will now test 72 units per year ($1000/14$). The entity has just one year left to get the test rate corrected. After a year, they again find three failures out of the 72 units tested. $3/72 = 4.2\%$ failures.

(Note that the entity has tried 10 years, and they were under the 4% limit; and they tried 14 years, and they were over the 4% limit. They must be back at 4% failures or less in the next year, so they might simply elect to go back to 10 years.)

Instead, in response to the 4.2% failure rate, the entity decreases the testing interval to 12 years. This means that they will now test 84 units per year (1,000/12). After a year, they again find three failures out of the 84 units tested. $3/84 = 3.6\%$ failures.

Entity found that they could maintain the failure rate at no more than 4% failures by maintaining the testing interval at 12 years or less. Entity chose 12-year interval and effectively extended their TBM (10 years) program by 20%.

A note of practicality is that an entity will probably be in better shape to lengthen the intervals between tests if the failure rate is less than 2%. But the requirements allow for annual adjustments, if the entity desires. As a matter of maintenance management, an ever-changing test rate (units tested/year) may be un-workable.

Note that the “5% of components” requirement effectively sets a practical limit of 20-year maximum PBM interval. Also of note is the “3 years” requirement; an entity might arbitrarily extend time intervals from six years to 20 years. In the event that an entity finds a failure rate greater than 4%, then the test rate must be accelerated such that within three years the failure rate must be brought back down to 4% or less.

Here is a table that demonstrates the values discussed:

Year #	Total Population (P)	Test Interval (I)	Units to be Tested (U= P/I)	# of Failures Found (F)	Failure Rate (=F/U)	Decision to Change Interval Yes or No	Interval Chose
1	1000	10 yrs	100	3	3%	Yes	20 yrs
2	1000	20 yrs	50	3	6%	Yes	16yrs
3	1000	16 yrs	63	3	4.8%	Yes	14 yrs
4	1000	14 yrs	72	3	4.2%	Yes	12 yrs
5	1000	12 yrs	84	3	3.6%	No	12 yrs

10. Overlapping the Verification of Sections of the Protection System

Tables 1-1 through 1-5 require that every Protection System component be periodically verified. One approach, but not the only method, is to test the entire protection scheme as a unit, from the secondary windings of voltage and current sources to breaker tripping. For practical ongoing verification, sections of the Protection System may be tested or monitored individually. The boundaries of the verified sections must overlap to ensure that there are no gaps in the verification. See Appendix A of this Supplementary Reference for additional discussion on this topic.

All of the methodologies expressed within this report may be combined by an entity, as appropriate, to establish and operate a maintenance program. For example, a Protection System may be divided into multiple overlapping sections with a different maintenance methodology for each section:

- Time-based maintenance with appropriate maximum verification intervals for categories of equipment, as given in the Tables 1-1 through 1-5;
- Monitoring as described in Tables 1-1 through 1-5;
- A Performance-Based Maintenance program as described in Section 9 above, or Attachment A of the standard;
- Opportunistic verification using analysis of Fault records, as described in Section 11

10.1 Frequently Asked Questions:

My system has alarms that are gathered once daily through an auto-polling system; this is not really a conventional SCADA system but does it meet the Table 1 requirements for inclusion as a monitored system?

Yes, provided the auto-polling that gathers the alarms reports those alarms to a location where the action can be initiated to correct the Unresolved Maintenance Issue. This location does not have to be the location of the engineer or the technician that will eventually repair the problem, but rather a location where the action can be initiated.

11. Monitoring by Analysis of Fault Records

Many users of microprocessor relays retrieve Fault event records and oscillographic records by data communications after a Fault. They analyze the data closely if there has been an apparent Misoperation, as NERC standards require. Some advanced users have commissioned automatic Fault record processing systems that gather and archive the data. They search for evidence of component failures or setting problems hidden behind an operation whose overall outcome seems to be correct. The relay data may be augmented with independently captured Digital Fault Recorder (DFR) data retrieved for the same event.

Fault data analysis comprises a legitimate CBM program that is capable of reducing the need for a manual time-interval based check on Protection Systems whose operations are analyzed. Even electromechanical Protection Systems instrumented with DFR channels may achieve some CBM benefit. The completeness of the verification then depends on the number and variety of Faults in the vicinity of the relay that produce relay response records and the specific data captured.

A typical Fault record will verify particular parts of certain Protection Systems in the vicinity of the Fault. For a given Protection System installation, it may or may not be possible to gather within a reasonable amount of time an ensemble of internal and external Fault records that completely verify the Protection System.

For example, Fault records may verify that the particular relays that tripped are able to trip via the control circuit path that was specifically used to clear that Fault. A relay or DFR record may indicate correct operation of the protection communications channel. Furthermore, other nearby Protection Systems may verify that they restrain from tripping for a Fault just outside their respective zones of protection. The ensemble of internal Fault and nearby external Fault event data can verify major portions of the Protection System, and reset the time clock for the Table 1 testing intervals for the verified components only.

What can be shown from the records of one operation is very specific and limited. In a panel with multiple relays, only the specific relay(s) whose operation can be observed without ambiguity should be used. Be careful about using Fault response data to verify that settings or calibration are correct. Unless records have been captured for multiple Faults close to either side of a setting boundary, setting or calibration could still be incorrect.

PMU data, much like DME data, can be utilized to prove various components of the Protection System. Obviously, care must be taken to attribute proof only to the parts of a Protection System that can actually be proven using the PMU or DME data.

If Fault record data is used to show that portions or all of a Protection System have been verified to meet Table 1 requirements, the owner must retain the Fault records used, and the maintenance-related conclusions drawn from this data and used to defer Table 1 tests, for at least the retention time interval given in Section 8.2.

11.1 Frequently Asked Questions:

I use my protective relays for Fault and Disturbance recording, collecting oscillographic records and event records via communications for Fault analysis to meet NERC and DME requirements. What are the maintenance requirements for the relays?

For relays used only as Disturbance Monitoring Equipment, NERC Standard PRC-018-1 R3 & R6 states the maintenance requirements and is being addressed by a standards activity that is revising PRC-002-1 and PRC-018-1. For protective relays “that are designed to provide protection for the BES,” this standard applies, even if they also perform DME functions.

12. Importance of Relay Settings in Maintenance Programs

In manual testing programs, many utilities depend on pickup value or zone boundary tests to show that the relays have correct settings and calibration. Microprocessor relays, by contrast, provide the means for continuously monitoring measurement accuracy. Furthermore, the relay digitizes inputs from one set of signals to perform all measurement functions in a single self-monitoring microprocessor system. These relays do not require testing or calibration of each setting.

However, incorrect settings may be a bigger risk with microprocessor relays than with older relays. Some microprocessor relays have hundreds or thousands of settings, many of which are critical to Protection System performance.

Monitoring does not check measuring element settings. Analysis of Fault records may or may not reveal setting problems. To minimize risk of setting errors after commissioning, the user should enforce strict settings data base management, with reconfirmation (manual or automatic) that the installed settings are correct whenever maintenance activity might have changed them; for background and guidance, see [5] in References.

Table 1 requires that settings must be verified to be as specified. The reason for this requirement is simple: With legacy relays (non-microprocessor protective relays), it is necessary to know the value of the intended setting in order to test, adjust and calibrate the relay. Proving that the relay works per specified setting was the de facto procedure. However, with the advanced microprocessor relays, it is possible to change relay settings for the purpose of verifying specific functions and then neglect to return the settings to the specified values. While there is no specific requirement to maintain a settings management process, there remains a need to verify that the settings left in the relay are the intended, specified settings. This need may manifest itself after any of the following:

- One or more settings are changed for any reason.
- A relay fails and is repaired or replaced with another unit.
- A relay is upgraded with a new firmware version.

12.1 Frequently Asked Questions:

How do I approach testing when I have to upgrade firmware of a microprocessor relay?

The entity should ensure that the relay continues to function properly after implementation of firmware changes. Some entities may have a [Research and Development \(R&D\)](#) department that might routinely run acceptance tests on devices with firmware upgrades before allowing the upgrade to be installed. Other entities may rely upon the vigorous testing of the firmware OEM. An entity has the latitude to install devices and/or programming that they believe will perform to their satisfaction. If an entity should choose to perform the maintenance activities specified in the Tables following a firmware upgrade, then they may, if they choose, reset the time clock on that set of maintenance activities so that they would not have to repeat the maintenance on

its regularly scheduled cycle. (However, for simplicity in maintenance schedules, some entities may choose to not reset this time clock; it is merely a suggested option.)

If I upgrade my old relays, then do I have to maintain my previous equipment maintenance documentation?

If an equipment item is repaired or replaced, then the entity can restart the maintenance-activity-time-interval-clock, if desired; however, the replacement of equipment does not remove any documentation requirements. The requirements in the standard are intended to ensure that an entity has a maintenance plan, and that the entity adheres to minimum activities and maximum time intervals. The documentation requirements are intended to help an entity demonstrate compliance. For example, saving the dates and records of the last two maintenance activities is intended to demonstrate compliance with the interval. Therefore, if you upgrade or replace equipment, then you still must maintain the documentation for the previous equipment, thus demonstrating compliance with the time interval requirement prior to the replacement action.

We have a number of installations where we have changed our Protection System components. Some of the changes were upgrades, but others were simply system rating changes that merely required taking relays "out-of-service". What are our responsibilities when it comes to "out-of-service" devices?

Assuming that your system up-rates, upgrades and overall changes meet any and all other requirements and standards, then the requirements of PRC-005-4-6 are simple – if the Protection System component performs a Protection System function, then it must be maintained. If the component no longer performs Protection System functions, then it does not require maintenance activities under the Tables of PRC-005-4-6. While many entities might physically remove a component that is no longer needed, there is no requirement in PRC-005-4-6 to remove such component(s). Obviously, prudence would dictate that an “out-of-service” device is truly made inactive. There are no record requirements listed in PRC-005-4-6 for Protection System components not used.

While performing relay testing of a protective device on our Bulk Electric System, it was discovered that the protective device being tested was either broken or out of calibration. Does this satisfy the relay testing requirement, even though the protective device tested bad, and may be unable to be placed back into service?

Yes, PRC-005-4-6 requires entities to perform relay testing on protective devices on a given maintenance cycle interval. By performing this testing, the entity has satisfied PRC-005-4-6 requirement, although the protective device may be unable to be returned to service under normal calibration adjustments. [Requirement R5](#) states:

“R5. Each Transmission Owner, Generator Owner, and Distribution Provider shall demonstrate efforts to correct any identified Unresolved Maintenance Issues.”

Also, when a failure occurs in a Protection System, power system security may be comprised, and notification of the failure must be conducted in accordance with relevant NERC standards.

If I show the protective device out of service while it is being repaired, then can I add it back as a new protective device when it returns? If not, my relay testing history would show that I was out of compliance for the last maintenance cycle.

The maintenance and testing requirements ([Requirement R5](#)) state “...shall demonstrate efforts to correct any identified Unresolved Maintenance Issues...” The type of corrective activity is not stated; however, it could include repairs or replacements.

Your documentation requirements will increase, of course, to demonstrate that your device tested bad and had corrective actions initiated. Your regional entity might ask about the status of your corrective actions.

13. Self-Monitoring Capabilities and Limitations

Microprocessor relay proponents have cited the self-monitoring capabilities of these products for nearly 20 years. Theoretically, any element that is monitored does not need a periodic manual test. A problem today is that the community of manufacturers and users has not created clear documentation of exactly what is and is not monitored. Some unmonitored but critical elements are buried in installed systems that are described as self-monitoring.

To utilize the extended time intervals allowed by monitoring, the user must document that the monitoring attributes of the device match the minimum requirements listed in the Table 1.

Until users are able to document how all parts of a system which are required for the protective functions are monitored or verified (with help from manufacturers), they must continue with the unmonitored intervals established in Tables [1](#), [3](#), [4](#) and [5 and any associated sub-tables](#) [Table 3](#).

Going forward, manufacturers and users can develop mappings of the monitoring within relays, and monitoring coverage by the relay of user circuits connected to the relay terminals.

To enable the use of the most extensive monitoring (and never again have a hands-on maintenance requirement), the manufacturers of the microprocessor-based self-monitoring components in the Protection System should publish for the user a document or map that shows:

- How all internal elements of the product are monitored for any failure that could impact Protection System performance.
- Which connected circuits are monitored by checks implemented within the product; how to connect and set the product to assure monitoring of these connected circuits; and what circuits or potential problems are not monitored.

This manufacturer's information can be used by the registered entity to document compliance of the monitoring attributes requirements by:

- Presenting or referencing the product manufacturer's documents.
- Explaining in a system design document the mapping of how every component and circuit that is critical to protection is monitored by the microprocessor product(s) or by other design features.
- Extending the monitoring to include the alarm transmission Facilities through which failures are reported within a given time frame to allocate where action can be taken to initiate resolution of the alarm attributed to an Unresolved Maintenance Issue, so that failures of monitoring or alarming systems also lead to alarms and action.
- Documenting the plans for verification of any unmonitored components according to the requirements of Tables [1](#), [3](#), [4](#) and [5 and any associated sub-tables](#) [Table 3](#).

13.1 Frequently Asked Questions:

I can't figure out how to demonstrate compliance with the requirements for the highest level of monitoring of Protection Systems. Why does this Maintenance Standard describe a maintenance program approach I cannot achieve?

Demonstrating compliance with the requirements for the highest level of monitoring any particular component of Protection Systems is likely to be very involved, and may include detailed manufacturer documentation of complete internal monitoring within a device, comprehensive design drawing reviews, and other detailed documentation. This standard does not presume to specify what documentation must be developed; only that it must be documented.

There may actually be some equipment available that is capable of meeting these highest levels of monitoring criteria, in which case it may be maintained according to the highest level of monitoring shown on the Tables. However, even if there is no equipment available today that can meet this level of monitoring, the standard establishes the necessary requirements for when such equipment becomes available.

By creating a roadmap for development, this provision makes the standard technology-neutral. The Standard Drafting Team wants to avoid the need to revise the standard in a few years to accommodate technology advances that may be coming to the industry.

14. Notification of Protection System or Automatic Reclosing Failures

When a failure occurs in a Protection System or Automatic Reclosing, power system security may be compromised, and notification of the failure must be conducted in accordance with relevant NERC standard(s). Knowledge of the failure may impact the system operator's decisions on acceptable Loading conditions.

This formal reporting of the failure and repair status to the system operator by the Protection System or Automatic Reclosing owner also encourages the system owner to execute repairs as rapidly as possible. In some cases, a microprocessor relay or carrier set can be replaced in hours; wiring termination failures may be repaired in a similar time frame. On the other hand, a component in an electromechanical or early-generation electronic relay may be difficult to find and may hold up repair for weeks. In some situations, the owner may have to resort to a temporary protection panel, or complete panel replacement.

15. Maintenance Activities

Some specific maintenance activities are a requirement to ensure reliability. An example would be that a BES entity could be prudent in its protective relay maintenance, but if its battery maintenance program is lacking, then reliability could still suffer. The NERC glossary outlines a Protection System as containing specific components. PRC-005-4-6 requires specific maintenance activities be accomplished within a specific time interval. As noted previously, higher technology equipment can contain integral monitoring capability that actually performs maintenance verification activities routinely and often; therefore, *manual intervention* to perform certain activities on these type components may not be needed.

15.1 Protective Relays (Table 1-1)

These relays are defined as the devices that receive the input signal from the current and voltage sensing devices and are used to isolate a Faulted Element of the BES. Devices that sense thermal, vibration, seismic, gas, or any other non-electrical inputs are excluded.

Non-microprocessor based equipment is treated differently than microprocessor-based equipment in the following ways; the relays should meet the asset owners' tolerances:

- Non-microprocessor devices must be tested with voltage and/or current applied to the device.
- Microprocessor devices may be tested through the integral testing of the device.
 - There is no specific protective relay commissioning test or relay routine test mandated.
 - There is no specific documentation mandated.

15.1.1 Frequently Asked Questions:

What calibration tolerance should be applied on electromechanical relays?

Each entity establishes their own acceptable tolerances when applying protective relaying on their system. For some Protection System components, adjustment is required to bring measurement accuracy within the parameters established by the asset owner based on the specific application of the component. A calibration failure is the result if testing finds the specified parameters to be out of tolerance.

15.2 Voltage & Current Sensing Devices (Table 1-3)

These are the current and voltage sensing devices, usually known as instrument transformers. There is presently a technology available (fiber-optic Hall-effect) that does not utilize conventional transformer technology; these devices and other technologies that produce quantities that represent the primary values of voltage and current are considered to be a type of voltage and current sensing devices included in this standard.

The intent of the maintenance activity is to verify the input to the protective relay from the device that produces the current or voltage signal sample.

There is no specific test mandated for these components. The important thing about these signals is to know that the expected output from these components actually reaches the protective relay. Therefore, the proof of the proper operation of these components also demonstrates the integrity of the wiring (or other medium used to convey the signal) from the current and voltage sensing device, all the way to the protective relay. The following observations apply:

- There is no specific ratio test, routine test or commissioning test mandated.
- There is no specific documentation mandated.
- It is required that the signal be present at the relay.
- This expectation can be arrived at from any of a number of means; including, but not limited to, the following: By calculation, by comparison to other circuits, by commissioning tests, by thorough inspection, or by any means needed to verify the circuit meets the asset owner's Protection System maintenance program.
- An example of testing might be a saturation test of a CT with the test values applied at the relay panel; this, therefore, tests the CT, as well as the wiring from the relay all the back to the CT.
- Another possible test is to measure the signal from the voltage and/or current sensing devices, during Load conditions, at the input to the relay.
- Another example of testing the various voltage and/or current sensing devices is to query the microprocessor relay for the Real-time Loading; this can then be compared to other devices to verify the quantities applied to this relay. Since the input devices have supplied the proper values to the protective relay, then the verification activity has been satisfied. Thus, event reports (and oscillographs) can be used to verify that the voltage and current sensing devices are performing satisfactorily.
- Still another method is to measure total watts and ~~VAr~~sVAr around the entire bus; this should add up to zero watts and zero ~~VAr~~svars, thus proving the voltage and/or current sensing devices system throughout the bus.
- Another method for proving the voltage and/or current-sensing devices is to complete commissioning tests on all of the transformers, cabling, fuses and wiring.
- Any other method that verifies the input to the protective relay from the device that produces the current or voltage signal sample.

15.2.1 Frequently Asked Questions:

What is meant by "...verify the current and voltage circuit inputs from the voltage and current sensing devices to the protective relays ..." Do we need to perform ratio, polarity and saturation tests every few years?

No. ~~Y--you~~You must verify that the protective relay is receiving the expected values from the voltage and current-sensing devices (typically voltage and current transformers). This can be as difficult as is proposed by the question (with additional testing on the cabling and substation wiring to ensure that the values arrive at the relays); or simplicity can be achieved by other verification methods. While some examples follow, these are not intended to represent an all-inclusive list; technology advances and ingenuity should not be excluded from making comparisons and verifications:

- Compare the secondary values, at the relay, to a metering circuit, fed by different current transformers, monitoring the same line as the questioned relay circuit.
- Compare the individual phase secondary values at the relay panel (with additional testing on the panel wiring to ensure that the values arrive at those relays) with the other phases, and verify that residual currents are within expected bounds.
- Observe all three phase currents and the residual current at the relay panel with an oscilloscope, observing comparable magnitudes and proper phase relationship, with additional testing on the panel wiring to ensure that the values arrive at the relays.
- Compare the values, as determined by the questioned relay (such as, but not limited to, a query to the microprocessor relay) to another protective relay monitoring the same line, with currents supplied by different CTs.
- Compare the secondary values, at the relay with values measured by test instruments (such as, but not limited to multi-meters, voltmeter, clamp-on ammeters, etc.) and verified by calculations and known ratios to be the values expected. For example, a single PT on a ~~100 KV~~100KV bus will have a specific secondary value that, when multiplied by the PT ratio, arrives at the expected bus value of ~~100 KV~~100KV.
- Query SCADA for the power flows at the far end of the line protected by the questioned relay, compare those SCADA values to the values as determined by the questioned relay.
- Totalize the Watts and ~~VARs~~vars on the bus and compare the totals to the values as seen by the questioned relay.

The point of the verification procedure is to ensure that all of the individual components are functioning properly; and that an ongoing proactive procedure is in place to re-check the various components of the protective relay measuring Systems.

Is wiring insulation or hi-pot testing required by this Maintenance Standard?

No, ~~---~~wiring insulation and equipment hi-pot testing are not specifically required by the Maintenance Standard. However, if the method of verifying CT and PT inputs to the relay involves some other method than actual observation of current and voltage transformer secondary inputs to the relay, it might be necessary to perform some sort of cable integrity test to verify that the instrument transformer secondary signals are actually making it to the relay and not being

shunted off to ground. For instance, you could use CT excitation tests and PT turns ratio tests and compare to baseline values to verify that the instrument transformer outputs are acceptable. However, to conclude that these acceptable transformer instrument output signals are actually making it to the relay inputs, it also would be necessary to verify the insulation of the wiring between the instrument transformer and the relay.

My plant generator and transformer relays are electromechanical and do not have metering functions, as do microprocessor-based relays. In order for me to compare the instrument transformer inputs to these relays to the secondary values of other metered instrument transformers monitoring the same primary voltage and current signals, it would be necessary to temporarily connect test equipment, like voltmeters and clamp on ammeters, to measure the input signals to the relays. This practice seems very risky, and a plant trip could result if the technician were to make an error while measuring these current and voltage signals. How can I avoid this risk? Also, what if no other instrument transformers are available which monitor the same primary voltage or current signal?

Comparing the input signals to the relays to the outputs of other independent instrument transformers monitoring the same primary current or voltage is just one method of verifying the instrument transformer inputs to the relays, but is not required by the standard. Plants can choose how to best manage their risk. If online testing is deemed too risky, offline tests, such as, but not limited to, CT excitation test and PT turns ratio tests can be compared to baseline data and be used in conjunction with CT and PT secondary wiring insulation verification tests to adequately “verify the current and voltage circuit inputs from the voltage and current sensing devices to the protective relays...” while eliminating the risk of tripping an in service generator or transformer. Similarly, this same offline test methodology can be used to verify the relay input voltage and current signals to relays when there are no other instrument transformers monitoring available for purposes of signal comparison.

15.3 Control circuitry associated with protective functions (Table 1-5)

This component of Protection Systems includes the trip coil(s) of the circuit breaker, circuit switcher or any other interrupting device. It includes the wiring from the batteries to the relays. It includes the wiring (or other signal conveyance) from every trip output to every trip coil. It includes any device needed for the correct processing of the needed trip signal to the trip coil of the interrupting device; this requirement is meant to capture inputs and outputs to and from a protective relay that are necessary for the correct operation of the protective functions. In short, every trip path must be verified; the method of verification is optional to the asset owner. An example of testing methods to accomplish this might be to verify, with a volt-meter, the existence of the proper voltage at the open contacts, the open circuited input circuit and at the trip coil(s). As every parallel trip path has similar failure modes, each trip path from relay to trip coil must be verified. Each trip coil must be tested to trip the circuit breaker (or other interrupting device) at least once. There is a requirement to operate the circuit breaker (or other interrupting device) at least once every six years as part of the complete functional test. If a suitable monitoring system is installed that verifies every parallel trip path, then the manual-intervention testing of those parallel trip paths can be eliminated; however, the actual operation of the circuit breaker must still occur at least once every six years. This six-year tripping requirement can be completed as easily as tracking the Real-time Fault-clearing operations on the circuit breaker, or tracking the trip coil(s) operation(s) during circuit breaker routine maintenance actions.

The circuit-interrupting device should not be confused with a motor-operated disconnect. The intent of this standard is to require maintenance intervals and activities on Protection Systems equipment, and not just all system isolating equipment.

It is necessary, however, to classify a device that actuates a high-speed auto-closing ground switch as an interrupting device, if this ground switch is utilized in a Protection System and forces a ground Fault to occur that then results in an expected Protection System operation to clear the forced ground Fault. The SDT believes that this is essentially a transferred-tripping device without the use of communications equipment. If this high-speed ground switch is “...designed to provide protection for the BES...” then this device needs to be treated as any other Protection System component. The control circuitry would have to be tested within 12 years, and any electromechanically operated device will have to be tested every six years. If the spring-operated ground switch can be disconnected from the solenoid triggering unit, then the solenoid triggering unit can easily be tested without the actual closing of the ground blade.

The dc control circuitry also includes each auxiliary tripping relay (94) and each lock-out relay (86) that may exist in any particular trip scheme. If the lock-out relays (86) are electromechanical type components, then they must be trip tested. The PSMT SDT considers these components to share some similarities in failure modes as electromechanical protective relays; as such, there is a six-year maximum interval between mandated maintenance tasks unless PBM is applied.

Contacts of the 86 and/or 94 that pass the trip current on to the circuit interrupting device trip coils will have to be checked as part of the 12 year requirement. Contacts of the 86 and/or 94 lock relay that operate non-BES interrupting devices are not required. Normally-open contacts that are not used to pass a trip signal and normally-closed contacts do not have to be verified. Verification of the tripping paths is the requirement.

New technology is also accommodated here; there are some tripping systems that have replaced the traditional hard-wired trip circuitry with other methods of trip-signal conveyance such as fiber-optics. It is the intent of the PSMT SDT to include this, and any other, technology that is used to convey a trip signal from a protective relay to a circuit breaker (or other interrupting device) within this category of equipment. The requirement for these systems is verification of the tripping path.

Monitoring of the control circuit integrity allows for no maintenance activity on the control circuit (excluding the requirement to operate trip coils and electromechanical lockout and/or tripping auxiliary relays). Monitoring of integrity means to monitor for continuity and/or presence of voltage on each trip path. For Ethernet or fiber-optic control systems, monitoring of integrity means to monitor communication ability between the relay and the circuit breaker.

15.3.1 Frequently Asked Questions:

Is it permissible to verify circuit breaker tripping at a different time (and interval) than when we verify the protective relays and the instrument transformers?

Yes, ~~---~~ provided the entire Protective System is tested within the individual component’s maximum allowable testing intervals.

The Protection System Maintenance Standard describes requirements for verifying the tripping of circuit breakers. What is this telling me about maintenance of circuit breakers?

Requirements in PRC-005-4-6 are intended to verify the integrity of tripping circuits, including the breaker trip coil, as well as the presence of auxiliary supply (usually a battery) for energizing the trip coil if a protection function operates. Beyond this, PRC-005-4-6 sets no requirements for verifying circuit breaker performance, or for maintenance of the circuit breaker.

How do I test each dc Control Circuit trip path, as established in Table 1-5 "Protection System Control Circuitry (Trip coils and auxiliary relays)"?

Table 1-5 specifies that each breaker trip coil and lockout relays that carry trip current to a trip coil must be operated within the specified time period. The required operations may be via targeted maintenance activities, or by documented operation of these devices for other purposes such as Fault clearing.

Are high-speed ground switch trip coils included in the dc control circuitry?

Yes—PRC-005-4-6 includes high-speed grounding switch trip coils within the dc control circuitry to the degree that the initiating Protection Systems are characterized as “transmission Protection Systems.”

Does the control circuitry and trip coil of a non-BES breaker, tripped via a BES protection component, have to be tested per Table 1.5? (Refer to Table 3 for examples 1 and 2)

Example 1: A non-BES circuit breaker that is tripped via a Protection System to which PRC-005-4-6 applies might be (but is not limited to) a 12.5KV circuit breaker feeding (non-black-start) radial Loads but has a trip that originates from an under-frequency (81) relay.

- The relay must be verified.
- The voltage signal to the relay must be verified.
- All of the relevant dc supply tests still apply.
- The unmonitored trip circuit between the relay and any lock-out or auxiliary relay must be verified every 12 years.
- The unmonitored trip circuit between the lock-out (or auxiliary relay) and the non-BES breaker does not have to be proven with an electrical trip.
- In the case where there is no lock-out or auxiliary tripping relay used, the trip circuit to the non-BES breaker does not have to be proven with an electrical trip.
- The trip coil of the non-BES circuit breaker does not have to be individually proven with an electrical trip.

Example 2: A Transmission Owner may have a non-BES breaker that is tripped via a Protection System to which PRC-005-4-6 applies, which may be (but is not limited to) a 13.8 KV circuit breaker feeding (non-black-start) radial Loads but has a trip that originates from a BES 115KV line relay.

- The relay must be verified
- The voltage signal to the relay must be verified
- All of the relevant dc supply tests still apply

- The unmonitored trip circuit between the relay and any lock-out (86) or auxiliary (94) relay must be verified every 12 years
- The unmonitored trip circuit between the lock-out (86) (or auxiliary (94)) relay and the non-BES breaker does not have to be proven with an electrical trip
- In the case where there is no lockout (86) or auxiliary (94) tripping relay used, the trip circuit to the non-BES breaker does not have to be proven with an electrical trip.
- The trip coil of the non-BES circuit breaker does not have to be individually proven with an electrical trip

Example 3: A Generator Owner may have a non-BES circuit breaker that is tripped via a Protection System to which PRC-005-~~4~~6 applies, such as the generator field breaker and low-side breakers on station service/excitation transformers connected to the generator bus.

Trip testing of the generator field breaker and low side station service/excitation transformer breaker(s) via lockout or auxiliary tripping relays are not required since these breakers may be associated with radially fed loads and are not considered to be BES breakers. An example of an otherwise non-BES circuit breaker that is tripped via a BES protection component might be (but is not limited to) a 6.9kV station service transformer source circuit breaker but has a trip that originates from a generator differential (87) relay.

- The differential relay must be verified.
- The current signals to the relay must be verified.
- All of the relevant dc supply tests still apply.
- The unmonitored trip circuit between the relay and any lock-out or auxiliary relay must be verified every 12 years.
- The unmonitored trip circuit between the lock-out (or auxiliary relay) and the non-BES breaker does not have to be proven with an electrical trip.
- In the case where there is no lock-out or auxiliary tripping relay used, the trip circuit to the non-BES breaker does not have to be proven with an electrical trip.
- The trip coil of the non-BES circuit breaker does not have to be individually proven with an electrical trip.

However, it is very prudent to verify the tripping of such breakers for the integrity of the overall generation plant.

Do I have to verify operation of breaker "a" contacts or any other normally closed auxiliary contacts in the trip path of each breaker as part of my control circuit test?

Operation of normally-closed contacts does not have to be verified. Verification of the tripping paths is the requirement. The continuity of the normally closed contacts will be verified when the tripping path is verified.

15.4 Batteries and DC Supplies (Table 1-4)

The NERC definition of a Protection System is:

- Protective relays which respond to electrical quantities,

-
- Communications Systems necessary for correct operation of protective functions,
 - Voltage and current sensing devices providing inputs to protective relays,
 - Station dc supply associated with protective functions (including station batteries, battery chargers, and non-battery-based dc supply), and
 - Control circuitry associated with protective functions through the trip coil(s) of the circuit breakers or other interrupting devices.

The station battery is not the only component that provides dc power to a Protection System. In the new definition for Protection System, “station batteries” are replaced with “station dc supply” to make the battery charger and dc producing stored energy devices (that are not a battery) part of the Protection System that must be maintained.

The PSMT SDT recognizes that there are several technological advances in equipment and testing procedures that allow the owner to choose how to verify that a battery string is free of open circuits. The term “continuity” was introduced into the standard to allow the owner to choose how to verify continuity of a battery set by various methods, and not to limit the owner to other conventional methods of showing continuity. Continuity, as used in Table 1-4 of the standard, refers to verifying that there is a continuous current path from the positive terminal of the station battery set to the negative terminal. Without verifying continuity of a station battery, there is no way to determine that the station battery is available to supply dc power to the station. An open battery string will be an unavailable power source in the event of loss of the battery charger.

Batteries cannot be a unique population segment of a Performance-Based Maintenance Program (PBM) because there are too many variables in the electrochemical process to completely isolate all of the performance-changing criteria necessary for using PBM on battery Systems. However, nothing precludes the use of a PBM process for any other part of a dc supply besides the batteries themselves.

15.4.1 Frequently Asked Questions:

What constitutes the station dc supply, as mentioned in the definition of Protective System?

The previous definition of Protection System includes batteries, but leaves out chargers. The latest definition includes chargers, as well as dc systems that do not utilize batteries. This revision of PRC-005-~~4-6~~ is intended to capture these devices that were not included under the previous definition. The station direct current (dc) supply normally consists of two components: the battery charger and the station battery itself. There are also emerging technologies that provide a source of dc supply that does not include either a battery or charger.

Battery Charger - The battery charger is supplied by an available ac source. At a minimum, the battery charger must be sized to charge the battery (after discharge) and supply the constant dc load. In many cases, it may be sized also to provide sufficient dc current to handle the higher energy requirements of tripping breakers and switches when actuated by the protective relays in the Protection System.

Station Battery - Station batteries provide the dc power required for tripping and for supplying normal dc power to the station in the event of loss of the battery charger. There are several technologies of battery that require unique forms of maintenance as established in Table 1-4.

Emerging Technologies - Station dc supplies are currently being developed that use other energy storage technologies besides the station battery to prevent loss of the station dc supply when ac power is lost. Maintenance of these station dc supplies will require different kinds of tests and inspections. Table 1-4 presents maintenance activities and maximum allowable testing intervals for these new station dc supply technologies. However, because these technologies are relatively new, the maintenance activities for these station dc supplies may change over time.

What did the PSMT SDT mean by "continuity" of the dc supply?

The PSMT SDT recognizes that there are several technological advances in equipment and testing procedures that allow the owner to choose how to verify that a battery string is free of open circuits. The term "continuity" was introduced into the standard to allow the owner to choose how to verify continuity (no open circuits) of a battery set by various methods, and not to limit the owner to other conventional methods of showing continuity—lack of an open circuit. Continuity, as used in Table 1-4 of the standard, refers to verifying that there is a continuous current path from the positive terminal of the station battery set to the negative terminal (no open circuit). Without verifying continuity of a station battery, there is no way to determine that the station battery is available to supply dc power to the station. Whether it is caused from an open cell or a bad external connection, an open battery string will be an unavailable power source in the event of loss of the battery charger.

The current path through a station battery from its positive to its negative connection to the dc control circuits is composed of two types of elements. These path elements are the electrochemical path through each of its cells and all of the internal and external metallic connections and terminations of the batteries in the battery set. If there is loss of continuity (an open circuit) in any part of the electrochemical or metallic path, the battery set will not be available for service. In the event of the loss of the ac source or battery charger, the battery must be capable of supplying dc current, both for continuous dc loads and for tripping breakers and switches. Without continuity, the battery cannot perform this function.

At generating stations and large transmission stations where battery chargers are capable of handling the maximum current required by the Protection System, there are still problems that could potentially occur when the continuity through the connected battery is interrupted.

- Many battery chargers produce harmonics which can cause failure of dc power supplies in microprocessor-based protective relays and other electronic devices connected to station dc supply. In these cases, the substation battery serves as a filter for these harmonics. With the loss of continuity in the battery, the filter provided by the battery is no longer present.
- Loss of electrical continuity of the station battery will cause, in most battery chargers, regardless of the battery charger's output current capability, a delayed response in full output current from the charger. Almost all chargers have an intentional one- to two-second delay to switch from a low substation dc load current to the maximum output of the charger. This delay would cause the opening of circuit breakers to be delayed, which could violate system performance standards.

Monitoring of the station dc supply voltage will not indicate that there is a problem with the dc current path through the battery, unless the battery charger is taken out of service. At that time,

a break in the continuity of the station battery current path will be revealed because there will be no voltage on the station dc circuitry. This particular test method, while proving battery continuity, may not be acceptable to all installations.

Although the standard prescribes what must be accomplished during the maintenance activity, it does not prescribe how the maintenance activity should be accomplished. There are several methods that can be used to verify the electrical continuity of the battery. These are not the only possible methods, simply a sampling of some methods:

- One method is to measure that there is current flowing through the battery itself by a simple clamp on milliamp-range ammeter. A battery is always either charging or discharging. Even when a battery is charged, there is still a measurable float charge current that can be detected to verify that there is continuity in the electrical path through the battery.
- A simple test for continuity is to remove the battery charger from service and verify that the battery provides voltage and current to the dc system. However, the behavior of the various dc-supplied equipment in the station should be considered before using this approach.
- Manufacturers of microprocessor-controlled battery chargers have developed methods for their equipment to periodically (or continuously) test for battery continuity. For example, one manufacturer periodically reduces the float voltage on the battery until current from the battery to the dc load can be measured to confirm continuity.
- Applying test current (as in some ohmic testing devices, or devices for locating dc grounds) will provide a current that when measured elsewhere in the string, will prove that the circuit is continuous.
- Internal ohmic measurements of the cells and units of lead-acid batteries (VRLA & VLA) can detect lack of continuity within the cells of a battery string; and when used in conjunction with resistance measurements of the battery's external connections, can prove continuity. Also some methods of taking internal ohmic measurements, by their very nature, can prove the continuity of a battery string without having to use the results of resistance measurements of the external connections.
- Specific gravity tests could infer continuity because without continuity there could be no charging occurring; and if there is no charging, then specific gravity will go down below acceptable levels over time.

No matter how the electrical continuity of a battery set is verified, it is a necessary maintenance activity that must be performed at the intervals prescribed by Table 1-4 to insure that the station dc supply has a path that can provide the required current to the Protection System at all times.

When should I check the station batteries to see if they have sufficient energy to perform as manufactured?

The answer to this question depends on the type of battery (valve-regulated lead-acid, vented lead-acid, or nickel-cadmium) and the maintenance activity chosen.

For example, if you have a valve-regulated lead-acid (VRLA) station battery, and you have chosen to evaluate the measured cell/unit internal ohmic values to the battery cell's baseline, you will have to perform verification at a maximum maintenance interval of no greater than

every six months. While this interval might seem to be quite short, keep in mind that the six-month interval is important for VRLA batteries; this interval provides an accumulation of data that better shows when a VRLA battery is incapable of performing as manufactured.

If, for a VRLA station battery, you choose to conduct a performance capacity test on the entire station battery as the maintenance activity, then you will have to perform verification at a maximum maintenance interval of no greater than every three calendar years.

How is a baseline established for cell/unit internal ohmic measurements?

Establishment of cell/unit internal ohmic baseline measurements should be completed when lead-acid batteries are newly installed. To ensure that the baseline ohmic cell/unit values are most indicative of the station battery's ability to perform as manufactured, they should be made at some point in time after the installation to allow the cell chemistry to stabilize after the initial freshening charge. An accepted industry practice for establishing baseline values is after six-months of installation, with the battery fully charged and in service. However, it is recommended that each owner, when establishing a baseline, should consult the battery manufacturer for specific instructions on establishing an ohmic baseline for their product, if available.

When internal ohmic measurements are taken, the same make/model test equipment should be used to establish the baseline and used for the future trending of the cells internal ohmic measurements because of variances in test equipment and the type of ohmic measurement used by different manufacturer's equipment. Keep in mind that one manufacturer's "~~Conductance~~conductance" test equipment does not produce similar results as another manufacturer's "~~c~~Conductance" test equipment, even though both manufacturers have produced "~~Ohmic~~ohmic" test equipment. Therefore, for meaningful results to an established baseline, the same make/model of instrument should be used.

For all new installations of valve-regulated lead-acid (VRLA) batteries and vented lead-acid (VLA) batteries, where trending of the cells internal ohmic measurements to a baseline are to be used to determine the ability of the station battery to perform as manufactured, the establishment of the baseline, as described above, should be followed at the time of installation to insure the most accurate trending of the cell/unit. However, often for older VRLA batteries, the owners of the station batteries have not established a baseline at installation. Also for owners of VLA batteries who want to establish a maintenance activity which requires trending of measured ohmic values to a baseline, there was typically no baseline established at installation of the station battery to trend to.

To resolve the problem of the unavailability of baseline internal ohmic measurements for the individual cell/unit of a station battery, many manufacturers of internal ohmic measurement devices have established libraries of baseline values for VRLA and VLA batteries using their testing device. Also, several of the battery manufacturers have libraries of baselines for their products that can be used to trend to. However, it is important that when using battery manufacturer-supplied data that it is verified that the baseline readings to be used were taken with the same ohmic testing device that will be used for future measurements (for example "~~Conductance~~conductance ~~Readings~~readings~~Readings~~" from one manufacturer's test equipment do not correlate to "~~Impedance~~impedance ~~Readings~~readings~~Readings~~" from a different manufacturer's test equipment). Although many manufacturers may have provided baseline values, which will allow trending of the internal ohmic measurements over the remaining life of a station battery,

these baselines are not the actual cell/unit measurements for the battery being trended. It is important to have a baseline tailored to the station battery to more accurately use the tool of ohmic measurement trending. That more customized baseline can only be created by following the establishment of a baseline for each cell/unit at the time of installation of the station battery.

Why determine the State of Charge?

Even though there is no present requirement to check the state of charge of a battery, it can be a very useful tool in determining the overall condition of a battery system. The following discussions are offered as a general reference.

When a battery is fully charged, the battery is available to deliver its existing capacity. As a battery is discharged, its ability to deliver its maximum available capacity is diminished. It is necessary to determine if the state of charge has dropped to an unacceptable level.

What is State of Charge and how can it be determined in a station battery?

The state of charge of a battery refers to the ratio of residual capacity at a given instant to the maximum capacity available from the battery. When a battery is fully charged, the battery is available to deliver its existing capacity. As a battery is discharged, its ability to deliver its maximum available capacity is diminished. Knowing the amount of energy left in a battery compared with the energy it had when it was fully charged gives the user an indication of how much longer a battery will continue to perform before it needs recharging.

For vented lead-acid (VLA) batteries which use accessible liquid electrolyte, a hydrometer can be used to test the specific gravity of each cell as a measure of its state of charge. The hydrometer depends on measuring changes in the weight of the active chemicals. As the battery discharges, the active electrolyte, sulfuric acid, is consumed and the concentration of the sulfuric acid in water is reduced. This, in turn, reduces the specific gravity of the solution in direct proportion to the state of charge. The actual specific gravity of the electrolyte can, therefore, be used as an indication of the state of charge of the battery. Hydrometer readings may not tell the whole story, as it takes a while for the acid to get mixed up in the cells of a VLA battery. If measured right after charging, you might see high specific gravity readings at the top of the cell, even though it is much less at the bottom. Conversely, if taken shortly after adding water to the cell, the specific gravity readings near the top of the cell will be lower than those at the bottom.

Nickel-cadmium batteries, where the specific gravity of the electrolyte does not change during battery charge and discharge, and valve-regulated lead-acid (VRLA) batteries, where the electrolyte is not accessible, cannot have their state of charge determined by specific gravity readings. For these two types of batteries, and for VLA batteries also, where another method besides taking hydrometer readings is desired, the state of charge may be determined by taking voltage and current readings at the battery terminals. The methods employed to obtain accurate readings vary for the different battery types. Manufacturers' information and IEEE guidelines can be consulted for specifics; (see IEEE 1106 Annex B for Nickel Cadmium batteries, IEEE 1188 Annex A for VRLA batteries and IEEE 450 for VLA batteries).

Why determine the Connection Resistance?

High connection resistance can cause abnormal voltage drop or excessive heating during discharge of a station battery. During periods of a high rate of discharge of the station battery, a very high resistance can cause severe damage. The maintenance requirement to verify battery terminal connection resistance in Table 1-4 is established to verify that the integrity of all battery electrical connections is acceptable. This verification includes cell-to-cell (intercell) and external

circuit terminations. Your method of checking for acceptable values of intercell and terminal connection resistance could be by individual readings, or a combination of the two. There are test methods presently that can read post termination resistances and resistance values between external posts. There are also test methods presently available that take a combination reading of the post termination connection resistance plus the intercell resistance value plus the post termination connection resistance value. Either of the two methods, or any other method, that can show if the adequacy of connections at the battery posts is acceptable.

Adequacy of the electrical terminations can be determined by comparing resistance measurements for all connections taken at the time of station battery's installation to the same resistance measurements taken at the maintenance interval chosen, not to exceed the maximum maintenance interval of Table 1-4. Trending of the interval measurements to the baseline measurements will identify any degradation in the battery connections. When the connection resistance values exceed the acceptance criteria for the connection, the connection is typically disassembled, cleaned, reassembled and measurements taken to verify that the measurements are adequate when compared to the baseline readings.

What conditions should be inspected for visible battery cells?

The maintenance requirement to inspect the cell condition of all station battery cells where the cells are visible is a maintenance requirement of Table 1-4. Station batteries are different from any other component in the Protection Station because they are a perishable product due to the electrochemical process which is used to produce dc electrical current and voltage. This inspection is a detailed visual inspection of the cells for abnormalities that occur in the aging process of the cell. In VLA battery visual inspections, some of the things that the inspector is typically looking for on the plates are signs of sulfation of the plates, abnormal colors (which are an indicator of sulfation or possible copper contamination) and abnormal conditions such as cracked grids. The visual inspection could look for symptoms of hydration that would indicate that the battery has been left in a completely discharged state for a prolonged period. Besides looking at the plates for signs of aging, all internal connections, such as the bus bar connection to each plate, and the connections to all posts of the battery need to be visually inspected for abnormalities. In a complete visual inspection for the condition of the cell the cell plates, separators and sediment space of each cell must be looked at for signs of deterioration. An inspection of the station battery's cell condition also includes looking at all terminal posts and cell-to-cell electric connections to ensure they are corrosion free. The case of the battery containing the cell, or cells, must be inspected for cracks and electrolyte leaks through cracks and the post seals.

This maintenance activity cannot be extended beyond the maximum maintenance interval of Table 1-4 by a Performance-Based Maintenance Program (PBM) because of the electrochemical aging process of the station battery, nor can there be any monitoring associated with it because there must be a visual inspection involved in the activity. A remote visual inspection could possibly be done, but its interval must be no greater than the maximum maintenance interval of Table 1-4.

Why is it necessary to verify the battery string can perform as manufactured? I only care that the battery can trip the breaker, which means that the battery can perform as designed. I oversize my batteries so that even if the battery cannot perform as manufactured, it can still trip my breakers.

The fundamental answer to this question revolves around the concept of battery performance “as designed” vs. battery performance “as manufactured.” The purpose of the various sections of Table 1-4 of this standard is to establish requirements for the Protection System owner to maintain the batteries, to ensure they will operate the equipment when there is an incident that requires dc power, and ensure the batteries will continue to provide adequate service until at least the next maintenance interval. To meet these goals, the correct battery has to be properly selected to meet the design parameters, and the battery has to deliver the power it was manufactured to provide.

When testing batteries, it may be difficult to determine the original design (i.e., load profile) of the dc system. This standard is not intended as a design document, and requirements relating to design are, therefore, not included.

Where the dc load profile is known, the best way to determine if the system will operate as designed is to conduct a service test on the battery. However, a service test alone might not fully determine if the battery is healthy. A battery with 50% capacity may be able to pass a service test, but the battery would be in a serious state of deterioration and could fail at some point in the near future.

To ensure that the battery will meet the required load profile and continue to meet the load profile until the next maintenance interval, the installed battery must be sized correctly (i.e., a correct design), and it must be in a good state of health. Since the design of the dc system is not within the scope of the standard, the only consistent and reliable method to ensure that the battery is in a good state of health is to confirm that it can perform as manufactured. If the battery can perform as manufactured and it has been designed properly, the system should operate properly until the next maintenance interval.

How do I verify the battery string can perform as manufactured?

Optimally, actual battery performance should be verified against the manufacturer’s rating curves. The best practice for evaluating battery performance is via a performance test. However, due to both logistical and system reliability concerns, some Protection System owners prefer other methods to determine if a battery can perform as manufactured. There are several battery parameters that can be evaluated to determine if a battery can perform as manufactured. Ohmic measurements and float current are two examples of parameters that have been reported to assist in determining if a battery string can perform as manufactured.

The evaluation of battery parameters in determining battery health is a complex issue, and is not an exact science. This standard gives the user an opportunity to utilize other measured parameters to determine if the battery can perform as manufactured. It is the responsibility of the Protection System owner, however, to maintain a documented process that demonstrates the chosen parameter(s) and associated methodology used to determine if the battery string can perform as manufactured.

Whatever parameters are used to evaluate the battery (ohmic measurements, float current, float voltages, temperature, specific gravity, performance test, or combination thereof), the goal is to determine the value of the measurement (or the percentage change) at which the battery fails to perform as manufactured, or the point where the battery is deteriorating so rapidly that it will not perform as manufactured before the next maintenance interval.

This necessitates the need for establishing and documenting a baseline. A baseline may be required of every individual cell, a particular battery installation, or a specific make, model, or size of a cell. Given a consistent cell manufacturing process, it may be possible to establish a baseline number for the cell (make/model/type) and, therefore, a subsequent baseline for every installation would not be necessary. However, future installations of the same battery types should be spot-checked to ensure that your baseline remains applicable.

Consistent testing methods by trained personnel are essential. Moreover, it is essential that these technicians utilize the same make/model of ohmic test equipment each time readings are taken in order to establish a meaningful and accurate trend line against the established baseline. The type of probe and its location (post, connector, etc.) for the reading need to be the same for each subsequent test. The room temperature should be recorded with the readings for each test as well. Care should be taken to consider any factors that might lead a trending program to become invalid.

Float current along with other measurable parameters can be used in lieu of or in concert with ohmic measurement testing to measure the ability of a battery to perform as manufactured. The key to using any of these measurement parameters is to establish a baseline and the point where the reading indicates that the battery will not perform as manufactured.

The establishment of a baseline may be different for various types of cells and for different types of installations. In some cases, it may be possible to obtain a baseline number from the battery manufacturer, although it is much more likely that the baseline will have to be established after the installation is complete. To some degree, the battery may still be “forming” after installation; consequently, determining a stable baseline may not be possible until several months after the battery has been in service.

The most important part of this process is to determine the point where the ohmic reading (or other measured parameter(s)) indicates that the battery cannot perform as manufactured. That point could be an absolute number, an absolute change, or a percentage change of an established baseline.

Since there are no universally-accepted repositories of this information, the Protection System owner will have to determine the value/percentage where the battery cannot perform as manufactured (heretofore referred to as a failed cell). This is the most difficult and important part of the entire process.

To determine the point where the battery fails to perform as manufactured, it is helpful to have a history of a battery type, if the data includes the parameter(s) used to evaluate the battery's ability to perform as manufactured against the actual demonstrated performance/capacity of a battery/cell.

For example, when an ohmic reading has been recorded that the user suspects is indicating a failed cell, a performance test of that cell (or string) should be conducted in order to prove/quantify that the cell has failed. Through this process, the user needs to determine the ohmic value at which the performance of the cell has dropped below 80% of the manufactured, rated performance. It is likely that there may be a variation in ohmic readings that indicates a failed cell (possibly significant). It is prudent to use the most conservative values to determine the point at which the cell should be marked for replacement. Periodically, the user should

demonstrate that an “adequate” ohmic reading equates to an adequate battery performance (>80% of capacity).

Similarly, acceptance criteria for "good" and "failed" cells should be established for other parameters such as float current, specific gravity, etc., if used to determine the ability of a battery to function as designed.

What happens if I change the make/model of ohmic test equipment after the battery has been installed for a period of time?

If a user decides to switch testers, either voluntarily or because the equipment is not supported/sold any longer, the user may have to establish a new base line and new parameters that indicate when the battery no longer performs as manufactured. The user always has a choice to perform a capacity test in lieu of establishing new parameters.

What are some of the differences between lead-acid and nickel-cadmium batteries?

There is a marked difference in the aging process of lead acid and nickel-cadmium station batteries. The difference in the aging process of these two types of batteries is chiefly due to the electrochemical process of the battery type. Aging and eventual failure of lead acid batteries is due to expansion and corrosion of the positive grid structure, loss of positive plate active material, and loss of capacity caused by physical changes in the active material of the positive plates. In contrast, the primary failure of nickel-cadmium batteries is due to the gradual linear aging of the active materials in the plates. The electrolyte of a nickel-cadmium battery only facilitates the chemical reaction (it functions only to transfer ions between the positive and negative plates), but is not chemically altered during the process like the electrolyte of a lead acid battery. A lead acid battery experiences continued corrosion of the positive plate and grid structure throughout its operational life while a nickel-cadmium battery does not.

Changes to the properties of a lead acid battery when periodically measured and trended to a baseline, can indicate aging of the grid structure, positive plate deterioration, or changes in the active materials in the plate.

Because of the clear differences in the aging process of lead acid and nickel-cadmium batteries, there are no significantly measurable properties of the nickel-cadmium battery that can be measured at a periodic interval and trended to determine aging. For this reason, Table 1-4(c) (Protection System Station dc supply Using nickel-cadmium [NiCad] Batteries) only specifies one minimum maintenance activity and associated maximum maintenance interval necessary to verify that the station battery can perform as manufactured by evaluating cell/unit measurements indicative of battery performance against the station battery baseline. This maintenance activity is to conduct a performance or modified performance capacity test of the entire battery bank.

Why in Table 1-4 of PRC-005-4-6 is there a maintenance activity to inspect the structural integrity of the battery rack?

The purpose of this inspection is to verify that the battery rack is correctly installed and has no deterioration that could weaken its structural integrity.

Because the battery rack is specifically manufactured for the battery that is mounted on it, weakening of its structural members by rust or corrosion can physically jeopardize the battery.

What is required to comply with the "Unintentional dc Grounds" requirement?

In most cases, the first ground that appears on a battery is not a problem. It is the unintentional ground that appears on the opposite pole that becomes problematic. Even then many systems are designed to operate favorably under some unintentional ~~DC~~ dc ground situations. It is up to the owner of the Protection System to determine if corrective actions are needed on detected unintentional ~~DC~~ dc grounds. The standard merely requires that a check be made for the existence of unintentional dc grounds. ~~Unintentional dcDC gGrounds~~. Obviously, a “check-off” of some sort will have to be devised by the inspecting entity to document that a check is routinely done for unintentional ~~Unintentional DC dc grounds~~ Grounds because of the possible consequences to the Protection System.

Where the standard refers to “all cells,” is it sufficient to have a documentation method that refers to “all cells,” or do we need to have separate documentation for every cell? For example, do I need 60 individual documented check-offs for good electrolyte level, or would a single check-off per bank be sufficient?

A single check-off per battery bank is sufficient for documentation, as long as the single check-off attests to checking all cells/units.

Does this standard refer to Station batteries or all batteries; for example, Communications Site Batteries?

This standard refers to Station Batteries. The drafting team does not believe that the scope of this standard refers to communications sites. The batteries covered under PRC-005-~~4~~-6 are the batteries that supply the trip current to the trip coils of the interrupting devices that are a part of the Protection System. The SDT believes that a loss of power to the communications systems at a remote site would cause the communications systems associated with protective relays to alarm at the substation. At this point, the corrective actions can be initiated.

What are cell/unit internal ohmic measurements?

With the introduction of Valve-Regulated Lead-Acid (VRLA) batteries to station dc supplies in the 1980’s several of the standard maintenance tools that are used on Vented Lead-Acid (VLA) batteries were unable to be used on this new type of lead-acid battery to determine its state of health. The only tools that were available to give indication of the health of these new VRLA batteries were voltage readings of the total battery voltage, the voltage of the individual cells and periodic discharge tests.

In the search for a tool for determining the health of a VRLA battery several manufacturers studied the electrical model of a lead acid battery’s current path through its cell. The overall battery current path consists of resistance and inductive and capacitive reactance. The inductive reactance in the current path through the battery is so minuscule when compared to the huge capacitive reactance of the cells that it is often ignored in most circuit models of the battery cell. Taking the basic model of a battery cell manufacturers of battery test equipment have developed and marketed testing devices to take measurements of the current path to detect degradation in the internal path through the cell.

In the battery industry, these various types of measurements are referred to as ohmic measurements. Terms used by the industry to describe ohmic measurements are ac conductance, ac impedance, and dc resistance. They are defined by the test equipment providers and IEEE and refer to the method of taking ohmic measurements of a lead acid battery. For example, in one manufacturer’s ac conductance equipment measurements are taken by applying

a voltage of a known frequency and amplitude across a cell or battery unit and observing the ac current flow it produces in response to the voltage. A manufacturer of an ac impedance meter measures ac current of a known frequency and amplitude that is passed through the whole battery string and determines the impedances of each cell or unit by measuring the resultant ac voltage drop across them. On the other hand, dc resistance of a cell is measured by a third manufacturer's equipment by applying a dc load across the cell or unit and measuring the step change in both the voltage and current to calculate the internal dc resistance of the cell or unit.

It is important to note that because of the rapid development of the market for ohmic measurement devices, there were no standards developed or used to mandate the test signals used in making ohmic measurements. Manufacturers using proprietary methods and applying different frequencies and magnitudes for their signals have developed a diversity of measurement devices. This diversity in test signals coupled with the three different types of ohmic measurements techniques (impedance conductance and resistance) make it impossible to always get the same ohmic measurement for a cell with different ohmic measurement devices. However, IEEE has recognized the great value for choosing one device for ohmic measurement, no matter who makes it or the method to calculate the ohmic measurement. The only caution given by IEEE and the battery manufacturers is that when trending the cells of a lead acid station battery consistent ohmic measurement devices should be used to establish the baseline measurement and to trend the battery set for its entire life.

For VRLA batteries both IEEE Standard 1188 (Maintenance, Testing and Replacement of VRLA Batteries) and IEEE Standard 1187 (Installation Design and Installation of VRLA Batteries) recognize the importance of the maintenance activity of establishing a baseline for "cell/unit internal ohmic measurements (impedance, conductance and resistance)" and trending them at frequent intervals over the life of the battery. There are extensive discussions about the need for taking these measurements in these standards. IEEE Standard 1188 requires taking internal ohmic values as described in Annex C4 during regular inspections of the station battery. For VRLA batteries IEEE Standard 1188 in talking about the necessity of establishing a baseline and trending it over time says, "...depending on the degree of change a performance test, cell replacement or other corrective action may be necessary..." (IEEE std 1188-2005, C.4 page 18).

For VLA batteries IEEE Standard 484 (Installation of VLA batteries) gives several guidelines about establishing baseline measurements on newly installed lead acid stationary batteries. The standard also discusses the need to look for significant changes in the ohmic measurements, the caution that measurement data will differ with each type of model of instrument used, and lists a number of factors that affect ohmic measurements.

At the beginning of the 21st century, EPRI conducted a series of extensive studies to determine the relationship of internal ohmic measurements to the capacity of a lead acid battery cell. The studies indicated that internal ohmic measurements were in fact a good indicator of a lead acid battery cell's capacity, but because users often were only interested in the total station battery capacity and the technology does not precisely predict overall battery capacity, if a user only needs "an accurate measure of the overall battery capacity," they should "perform a battery capacity test."

Prior to the EPRI studies some large and small companies which owned and maintained station dc supplies in NERC Protection Systems developed maintenance programs where trending of ohmic measurements of cells/units of the station's battery became the maintenance activity for

determining if the station battery could perform as manufactured. By evaluation of the trending of the ohmic measurements over time, the owner could track the performance of the individual components of the station battery and determine if a total station battery or components of it required capacity testing, removal, replacement or in many instances replacement of the entire station battery. By taking this condition based approach these owners have eliminated having to perform capacity testing at prescribed intervals to determine if a battery needs to be replaced and are still able to effectively determine if a station battery can perform as manufactured.

My VRLA batteries have multiple-cells within an individual battery jar (or unit); how am I expected to comply with the cell-to-cell ohmic measurement requirements on these units that I cannot get to?

Measurement of cell/unit (not all batteries allow access to “individual cells” some “units” or jars may have multiple cells within a jar) internal ohmic values of all types of lead acid batteries where the cells of the battery are not visible is a station dc supply maintenance activity in Table 1-4. In cases where individual cells in a multi-cell unit are inaccessible, an ohmic measurement of the entire unit may be made.

I have a concern about my batteries being used to support additional auxiliary loads beyond my protection control systems in a generation station. Is ohmic measurement testing sufficient for my needs?

While this standard is focused on addressing requirements for Protection Systems, if batteries are used to service other load requirements beyond that of Protection Systems (e.g. pumps, valves, inverter loads), the functional entity may consider additional testing to confirm that the capacity of the battery is sufficient to support all loads.

Why verify voltage?

There are two required maintenance activities associated with verification of dc voltages in Table 1-4. These two required activities are to verify station dc supply voltage and float voltage of the battery charger, and have different maximum maintenance intervals. Both of these voltage verification requirements relate directly to the battery charger maintenance.

The verification of the dc supply voltage is simply an observation of battery voltage to prove that the charger has not been lost or is not malfunctioning; a reading taken from the battery charger panel meter or even SCADA values of the dc voltage could be some of the ways that one could satisfy the requirements. Low battery voltage below float voltage indicates that the battery may be on discharge and, if not corrected, the station battery could discharge down to some extremely low value that will not operate the Protection System. High voltage, close to or above the maximum allowable dc voltage for equipment connected to the station dc supply indicates the battery charger may be malfunctioning by producing high dc voltage levels on the Protection System. If corrective actions are not taken to bring the high voltage down, the dc power supplies and other electronic devices connected to the station dc supply may be damaged. The maintenance activity of verifying the float voltage of the battery charger is not to prove that a charger is lost or producing high voltages on the station dc supply, but rather to prove that the charger is properly floating the battery within the proper voltage limits. As above, there are many ways that this requirement can be met.

Why check for the electrolyte level?

In vented lead-acid (VLA) and nickel-cadmium (NiCad) batteries the visible electrolyte level must be checked as one of the required maintenance activities that must be performed at an interval that is equal to or less than the maximum maintenance interval of Table 1-4. Because the electrolyte level in valve-regulated lead-acid (VRLA) batteries cannot be observed, there is no maintenance activity listed in Table 1-4 of the standard for checking the electrolyte level. Low electrolyte level of any cell of a VLA or NiCad station battery is a condition requiring correction. Typically, the electrolyte level should be returned to an acceptable level for both types of batteries (VLA and NiCad) by adding distilled or other approved-quality water to the cell.

Often people confuse the interval for watering all cells required due to evaporation of the electrolyte in the station battery cells with the maximum maintenance interval required to check the electrolyte level. In many of the modern station batteries, the jar containing the electrolyte is so large with the band between the high and low electrolyte level so wide that normal evaporation which would require periodic watering of all cells takes several years to occur. However, because loss of electrolyte due to cracks in the jar, overcharging of the station battery, or other unforeseen events can cause rapid loss of electrolyte; the shorter maximum maintenance intervals for checking the electrolyte level are required. A low level of electrolyte in a VLA battery cell which exposes the tops of the plates can cause the exposed portion of the plates to accelerated sulfation resulting in loss of cell capacity. Also, in a VLA battery where the electrolyte level goes below the end of the cell withdrawal tube or filling funnel, gasses can exit the cell by the tube instead of the flame arrester and present an explosion hazard.

What are the parameters that can be evaluated in Tables 1-4(a) and 1-4(b)?

The most common parameter that is periodically trended and evaluated by industry today to verify that the station battery can perform as manufactured is internal ohmic cell/unit measurements.

In the mid-1990s, several large and small utilities began developing maintenance and testing programs for Protection System station batteries using a condition based maintenance approach of trending internal ohmic measurements to each station battery cell's baseline value. Battery owners use the data collected from this maintenance activity to determine (1) when a station battery requires a capacity test (instead of performing a capacity test on a predetermined, prescribed interval), (2) when an individual cell or battery unit should be replaced, or (3) based on the analysis of the trended data, if the station battery should be replaced without performing a capacity test.

Other examples of measurable parameters that can be periodically trended and evaluated for lead acid batteries are cell voltage, float current, connection resistance. However, periodically trending and evaluating cell/unit Ohmic measurements are the most common battery/cell parameters that are evaluated by industry to verify a lead acid battery string can perform as manufactured.

Why does it appear that there are two maintenance activities in Table 1-4(b) (for VRLA batteries) that appear to be the same activity and have the same maximum maintenance interval?

There are two different and distinct reasons for doing almost the same maintenance activity at the same interval for valve-regulated lead-acid (VRLA) batteries. The first similar activity for VRLA batteries (Table 1-4(b)) that has the same maximum maintenance interval is to "measure battery cell/unit internal ohmic values." Part of the reason for this activity is because the visual inspection of the cell condition is unavailable for VRLA batteries. Besides the requirement to

measure the internal ohmic measurements of VRLA batteries to determine the internal health of the cell, the maximum maintenance interval for this activity is significantly shorter than the interval for vented lead-acid (VLA) due to some unique failure modes for VRLA batteries. Some of the potential problems that VRLA batteries are susceptible to that do not affect VLA batteries are thermal runaway, cell dry-out, and cell reversal when one cell has a very low capacity.

The other similar activity listed in Table 1-4(b) is “...verify that the station battery can perform as manufactured by evaluating the measured cell/unit measurements indicative of battery performance (e.g. internal ohmic values) against the station battery baseline.” This activity allows an owner the option to choose between this activity with its much shorter maximum maintenance interval or the longer maximum maintenance interval for the maintenance activity to “Verify that the station battery can perform as manufactured by conducting a performance or modified performance capacity test of the entire battery bank.”

For VRLA batteries, there are two drivers for internal ohmic readings. The first driver is for a means to trend battery life. Trending against the baseline of VRLA cells in a battery string is essential to determine the approximate state of health of the battery. Ohmic measurement testing may be used as the mechanism for measuring the battery cells. If all the cells in the string exhibit a consistent trend line and that trend line has not risen above a specific deviation (e.g. 30%) over baseline for impedance tests or below baseline for conductance tests, then a judgment can be made that the battery is still in a reasonably good state of health and able to ‘perform as manufactured.’ It is essential that the specific deviation mentioned above is based on data (test or otherwise) that correlates the ohmic readings for a specific battery/tester combination to the health of the battery. This is the intent of the “perform as manufactured six-month test” at Row 4 on Table 1-4b.

The second big driver is VRLA batteries tendency for thermal runaway. This is the intent of the “thermal runaway test” at Row 2 on Table 1-4b. In order to detect a cell in thermal runaway, you need not necessarily have a formal trending program. When a single cell/unit changes significantly or significantly varies from the other cells (e.g. a doubling of resistance/impedance or a 50% decrease in conductance), there is a high probability that the cell/unit/string needs to be replaced as soon as possible. In other words, if the battery is 10 years old and all the cells have approached a significant change in ohmic values over baseline, then you have a battery which is approaching end of life. You need to get ready to buy a new battery, but you do not have to worry about an impending catastrophic failure. On the other hand, if the battery is five years old and you have one cell that has a markedly different ohmic reading than all the other cells, then you need to be worried that this cell is susceptible to thermal runaway. If the float (charging) current has risen significantly and the ohmic measurement has increased/decreased as described above then concern of catastrophic failure should trigger attention for corrective action.

If an entity elects to use a capacity test rather than a cell ohmic value trending program, this does not eliminate the need to be concerned about thermal runaway—the entity still needs to do the six-month readings and look for cells which are outliers in the string but they need not trend results against the factory/as new baseline. Some entities will not mind the extra administrative burden of having the ongoing trending program against baseline—others would rather just do

the capacity test and not have to trend the data against baseline. Nonetheless, all entities must look for ohmic outliers on a six-month basis.

It is possible to accomplish both tasks listed (trend testing for capability and testing for thermal runaway candidates) with the very same ohmic test. It becomes an analysis exercise of watching the trend from baselines and watching for the oblique cell measurement.

In table 1-4(f) (Exclusions for Protection System Station dc Supply Monitoring Devices and Systems), must all component attributes listed in the table be met before an exclusion can be granted for a maintenance activity?

Table 1-4(f) was created by the drafting team to allow Protection System dc supply owners to obtain exclusions from periodic maintenance activities by using monitoring devices. The basis of the exclusions granted in the table is that the monitoring devices must incorporate the monitoring capability of microprocessor based components which perform continuous self-monitoring. For failure of the microprocessor device used in dc supply monitoring, the self-checking routine in the microprocessor must generate an alarm which will be reported within 24 hours of device failure to a location where corrective action can be initiated.

Table 1-4(f) lists 8 component attributes along with a specific periodic maintenance activity associated with each of the 8 attributes listed. If an owner of a station dc supply wants to be excluded from periodically performing one of the 8 maintenance activities listed in table 1-4(f), the owner must have evidence that the monitoring and alarming component attributes associated with the excluded maintenance activity are met by the self-checking microprocessor based device with the specific component attribute listed in the table 1-4(f).

For example if an owner of a VLA station battery does not want to “verify station dc supply voltage” every “4 calendar months” (see table 1-4(a)), the owner can install a monitoring and alarming device “with high and low voltage monitoring and alarming of the battery charger voltage to detect charger overvoltage and charger failure” and “no periodic verification of station dc supply voltage is required” (see table 1-4(f) first row). However, if for the same Protection System discussed above, the owner does not install “electrolyte level monitoring and alarming in every cell” and “unintentional dc ground monitoring and alarming” (see second and third rows of table 1-4(f)), the owner will have to “inspect electrolyte level and for unintentional grounds” every “4 calendar months” (see table 1-4(a)).

15.5 Associated communications equipment (Table 1-2)

The equipment used for tripping in a communications-assisted trip scheme is a vital piece of the trip circuit. Remote action causing a local trip can be thought of as another parallel trip path to the trip coil that must be tested. Besides the trip output and wiring to the trip coil(s), there is also a communications medium that must be maintained. Newer technologies now exist that achieve communications-assisted tripping without the conventional wiring practices of older technology. For example, older technologies may have included Frequency Shift Key methods. This technology requires that guard and trip levels be maintained. The actual tripping path(s) to the trip coil(s) may be tested as a parallel trip path within the dc control circuitry tests. Emerging technologies transfer digital information over a variety of carrier mediums that are then

interpreted locally as trip signals. The requirements apply to the communicated signal needed for the proper operation of the protective relay trip logic or scheme. Therefore, this standard is applied to equipment used to convey both trip signals (permissive or direct) and block signals.

It was the intent of this standard to require that a test be performed on any communications-assisted trip scheme, regardless of the vintage of technology. The essential element is that the tripping (or blocking) occurs locally when the remote action has been asserted; or that the tripping (or blocking) occurs remotely when the local action is asserted. Note that the required testing can still be done within the concept of testing by overlapping segments. Associated communications equipment can be (but is not limited to) testing at other times and different frequencies as the protective relays, the individual trip paths and the affected circuit interrupting devices.

Some newer installations utilize digital signals over fiber-optics from the protective relays in the control house to the circuit interrupting device in the yard. This method of tripping the circuit breaker, even though it might be considered communications, must be maintained per the dc control circuitry maintenance requirements.

15.5.1 Frequently Asked Questions:

What are some examples of mechanisms to check communications equipment functioning?

For unmonitored Protection Systems, various types of communications systems will have different facilities for on-site integrity checking to be performed at least every four months during a substation visit. Some examples are, but not limited to:

- On-off power-line carrier systems can be checked by performing a manual carrier keying test between the line terminals, or carrier check-back test from one terminal.
- Systems which use frequency-shift communications with a continuous guard signal (over a telephone circuit, analog microwave system, etc.) can be checked by observing for a loss-of-guard indication or alarm. For frequency-shift power-line carrier systems, the guard signal level meter can also be checked.
- Hard-wired pilot wire line Protection Systems typically have pilot-wire monitoring relays that give an alarm indication for a pilot wire ground or open pilot wire circuit loop.
- Digital communications systems typically have a data reception indicator or data error indicator (based on loss of signal, bit error rate, or frame error checking).

For monitored Protection Systems, various types of communications systems will have different facilities for monitoring the presence of the communications channel, and activating alarms that can be monitored remotely. Some examples are, but not limited to:

- On-off power-line carrier systems can be shown to be operational by automated periodic power-line carrier check-back tests with remote alarming of failures.
- Systems which use a frequency-shift communications with a continuous guard signal (over a telephone circuit, analog microwave system, etc.) can be remotely monitored with a loss-of-guard alarm or low signal level alarm.
- Hard-wired pilot wire line Protection Systems can be monitored by remote alarming of pilot-wire monitoring relays.
- Digital communications systems can activate remotely monitored alarms for data reception loss or data error indications.
- Systems can be queried for the data error rates.

For the highest degree of monitoring of Protection Systems, the communications system must monitor all aspects of the performance and quality of the channel that show it meets the design performance criteria, including monitoring of the channel interface to protective relays.

- In many communications systems signal quality measurements, including signal-to-noise ratio, received signal level, reflected transmitter power or standing wave ratio, propagation delay, and data error rates are compared to alarm limits. These alarms are connected for remote monitoring.
- Alarms for inadequate performance are remotely monitored at all times, and the alarm communications system to the remote monitoring site must itself be continuously monitored to assure that the actual alarm status at the communications equipment location is continuously being reflected at the remote monitoring site.

What is needed for the four-month inspection of communications-assisted trip scheme equipment?

The four-month inspection applies to unmonitored equipment. An example of compliance with this requirement might be, but is not limited to:

With each site visit, check that the equipment is free from alarms; check any metered signal levels, and that power is still applied. While this might be explicit for a particular type of equipment (i.e., FSK equipment), the concept should be that the entity verify that the communications equipment that is used in a Protection System is operable through a cursory inspection and site visit. This site visit can be eliminated on this particular example if the FSK equipment had a monitored alarm on Loss of Guard. Blocking carrier systems with auto checkbacks will present an alarm when the channel fails allowing a visual indication. With no auto checkback, the channel integrity will need to be verified by a manual checkback or a two ended signal check. This check could also be eliminated by bring the auto checkback failure alarm to the monitored central location.

Does a fiber optic I/O scheme used for breaker tripping or control within a station, for example - transmitting a trip signal or control logic between the control house and the breaker control cabinet, constitute a communications system?

This equipment is presently classified as being part of the Protection System control circuitry and tested per the portions of Table 1 applicable to “Protection System Control Circuitry”, rather than those portions of the table applicable to communications equipment.

What is meant by "Channel" and "Communications Systems" in Table 1-2?

The transmission of logic or data from a relay in one station to a relay in another station for use in a pilot relay scheme will require a communications system of some sort. Typical relay communications systems use fiber optics, leased audio channels, power line carrier, and microwave. The overall communications system includes the channel and the associated communications equipment.

This standard refers to the “channel” as the medium between the transmitters and receivers in the relay panels such as a leased audio or digital communications circuit, power line and power line carrier auxiliary equipment, and fiber. The dividing line between the channel and the associated communications equipment is different for each type of media.

Examples of the Channel:

- Power Line Carrier (PLC) - The PLC channel starts and ends at the PLC transmitter and receiver output unless there is an internal hybrid. The channel includes the external hybrids, tuners, wave traps and the power line itself.
- Microwave –The channel includes the microwave multiplexers, radios, antennae and associated auxiliary equipment. The audio tone and digital transmitters and receivers in the relay panel are the associated communications equipment.
- Digital/Audio Circuit – The channel includes the equipment within and between the substations. The associated communications equipment includes the relay panel transmitters and receivers and the interface equipment in the relays.

-
- Fiber Optic – The channel starts at the fiber optic connectors on the fiber distribution panel at the local station and goes to the fiber optic distribution panel at the remote substation. The jumpers that connect the relaying equipment to the fiber distribution panel and any optical-electrical signal format converters are the associated communications equipment.

Figure 1-2, A-1 and A-2 at the end of this document show good examples of the communications channel and the associated communications equipment.

In Table 1-2, the Maintenance Activities section of the Protection System Communications Equipment and Channels refers to the quality of the channel meeting "performance criteria." What is meant by performance criteria?

Protection System communications channels must have a means of determining if the channel and communications equipment is operating normally. If the channel is not operating normally, an alarm will be indicated. For unmonitored systems, this alarm will probably be on the panel. For monitored systems, the alarm will be transmitted to a remote location.

Each entity will have established a nominal performance level for each Protection System communications channel that is consistent with proper functioning of the Protection System. If that level of nominal performance is not being met, the system will go into alarm. Following are some examples of Protection System communications channel performance measuring:

- For direct transfer trip using a frequency shift power line carrier channel, a guard level monitor is part of the equipment. A normal receive level is established when the system is calibrated and if the signal level drops below an established level, the system will indicate an alarm.
- An on-off blocking signal over power line carrier is used for directional comparison blocking schemes on transmission lines. During a Fault, block logic is sent to the remote relays by turning on a local transmitter and sending the signal over the power line to a receiver at the remote end. This signal is normally off so continuous levels cannot be checked. These schemes use check-back testing to determine channel performance. A predetermined signal sequence is sent to the remote end and the remote end decodes this signal and sends a signal sequence back. If the sending end receives the correct information from the remote terminal, the test passes and no alarm is indicated. Full power and reduced power tests are typically run. Power levels for these tests are determined at the time of calibration.
- Pilot wire relay systems use a hardwire communications circuit to communicate between the local and remote ends of the protective zone. This circuit is monitored by circulating a dc current between the relay systems. A typical level may be 1 mA. If the level drops below the setting of the alarm monitor, the system will indicate an alarm.
- Modern digital relay systems use data communications to transmit relay information to the remote end relays. An example of this is a line current differential scheme commonly used on transmission lines. The protective relays communicate current magnitude and phase information over the communications path to determine if the Fault is located in the protective zone. Quantities such as digital packet loss, bit error rate and channel delay are monitored to determine the quality of the channel. These limits are determined and

set during relay commissioning. Once set, any channel quality problems that fall outside the set levels will indicate an alarm.

The previous examples show how some protective relay communications channels can be monitored and how the channel performance can be compared to performance criteria established by the entity. This standard does not state what the performance criteria will be; it just requires that the entity establish nominal criteria so Protection System channel monitoring can be performed.

How is the performance criteria of Protection System communications equipment involved in the maintenance program?

An entity determines the acceptable performance criteria, depending on the technology implemented. If the communications channel performance of a Protection System varies from the pre-determined performance criteria for that system, then these results should be investigated and resolved.

How do I verify the A/D converters of microprocessor-based relays?

There are a variety of ways to do this. Two examples would be: using values gathered via data communications and automatically comparing these values with values from other sources, or using groupings of other measurements (such as vector summation of bus feeder currents) for comparison. Many other methods are possible.

15.6 Alarms (Table 2)

In addition to the tables of maintenance for the components of a Protection System, there is an additional table added for alarms. This additional table was added for clarity. This enabled the common alarm attributes to be consolidated into a single spot, and, thus, make it easier to read the Tables 1-1 through 1-5, Table 3, and Table 4. The alarms need to arrive at a site wherein a corrective action can be initiated. This could be a control room, operations center, etc. The alarming mechanism can be a standard alarming system or an auto-polling system; the only requirement is that the alarm be brought to the action-site within 24 hours. This effectively makes manned-stations equivalent to monitored stations. The alarm of a monitored point (for example a monitored trip path with a lamp) in a manned-station now makes that monitored point eligible for monitored status. Obviously, these same rules apply to a non-manned-station, which is that if the monitored point has an alarm that is auto-reported to the operations center (for example) within 24 hours, then it too is considered monitored.

15.6.1 Frequently Asked Questions:

Why are there activities defined for varying degrees of monitoring a Protection System component when that level of technology may not yet be available?

There may already be some equipment available that is capable of meeting the highest levels of monitoring criteria listed in the Tables. However, even if there is no equipment available today that can meet this level of monitoring the standard establishes the necessary requirements for when such equipment becomes available. By creating a roadmap for development, this provision makes the standard technology neutral. The Standard Drafting Team wants to avoid the need to revise the standard in a few years to accommodate technology advances that may be coming to the industry.

Does a fail-safe "form b" contact that is alarmed to a 24/7 operation center classify as an alarm path with monitoring?

If the fail-safe "form-b" contact that is alarmed to a 24/7 operation center causes the alarm to activate for failure of any portion of the alarming path from the alarm origin to the 24/7 operations center, then this can be classified as an alarm path with monitoring.

15.7 Distributed UFLS and Distributed UVLS Systems (Table 3)

Distributed UFLS and distributed UVLS systems have their maintenance activities documented in Table 3 due to their distributed nature allowing reduced maintenance activities and extended maximum maintenance intervals. Relays have the same maintenance activities and intervals as Table 1-1. Voltage and current-sensing devices have the same maintenance activity and interval as Table 1-3. DC systems need only have their voltage read at the relay every 12 years. Control circuits have the following maintenance activities every 12 years:

- Verify the trip path between the relay and lock-out and/or auxiliary tripping device(s).
- Verify operation of any lock-out and/or auxiliary tripping device(s) used in the trip circuit.
- No verification of trip path required between the lock-out (and/or auxiliary tripping device) and the non-BES interrupting device.
- No verification of trip path required between the relay and trip coil for circuits that have no lock-out and/or auxiliary tripping device(s).
- No verification of trip coil required.

No maintenance activity is required for associated communication systems for distributed UFLS and distributed UVLS schemes.

Non-BES interrupting devices that participate in a distributed UFLS or distributed UVLS scheme are excluded from the tripping requirement, and part of the control circuit test requirement; however, the part of the trip path control circuitry between the Load-Shed relay and lock-out or auxiliary tripping relay must be tested at least once every 12 years. In the case where there is no lock-out or auxiliary tripping relay used in a distributed UFLS or UVLS scheme which is not part of the BES, there is no control circuit test requirement. There are many circuit interrupting devices in the distribution system that will be operating for any given under-frequency event that requires tripping for that event. A failure in the tripping action of a single distributed system circuit breaker (or non-BES equipment interruption device) will be far less significant than, for example, any single transmission Protection System failure, such as a failure of a bus differential lock-out relay. While many failures of these distributed system circuit breakers (or non-BES equipment interruption device) could add up to be significant, it is also believed that many circuit breakers are operated often on just Fault clearing duty; and, therefore, these circuit breakers are operated at least as frequently as any requirements that appear in this standard.

There are times when a Protection System component will be used on a BES device, as well as a non-BES device, such as a battery bank that serves both a BES circuit breaker and a non-BES interrupting device used for UFLS. In such a case, the battery bank (or other Protection System component) will be subject to the Tables of the standard because it is used for the BES.

15.7.1 Frequently Asked Questions:

The standard reaches further into the distribution system than we would like for UFLS and UVLS

While UFLS and UVLS equipment are located on the distribution network, their job is to protect the Bulk Electric System. This is not beyond the scope of NERC's [Section 215](#) authority.

FPA section 215(a) definitions section defines bulk power system as: "(A) facilities and control Systems necessary for operating an interconnected electric energy transmission network (or any portion thereof)." That definition, then, is limited by a later statement which adds the term bulk power system "...does not include facilities used in the local distribution of electric energy." Also, Section 215 also covers users, owners, and operators of bulk power Facilities.

UFLS and UVLS (when the UVLS is installed to prevent system voltage collapse or voltage instability for BES reliability) are not "used in the local distribution of electric energy," despite their location on local distribution networks. Further, if UFLS/UVLS Facilities were not covered by the reliability standards, then in order to protect the integrity of the BES during under-frequency or under-voltage events, that Load would have to be shed at the Transmission bus to ensure the Load-generation balance and voltage stability is maintained on the BES.

15.8 Automatic Reclosing (Table 4)

Please see the document referenced in Section F of PRC-005-3, "Considerations for Maintenance and Testing of Autoreclosing Schemes — November 2012", for a discussion of Automatic Reclosing as addressed in PRC-005-3.

15.8.1 Frequently-asked Questions

Automatic Reclosing is a control, not a protective function; why then is Automatic Reclosing maintenance included in the Protection System Maintenance Program (PSMP)?

Automatic Reclosing is a control function. The standard's title 'Protection System and Automatic Reclosing Maintenance' clearly distinguishes (separates) the Automatic Reclosing from the Protection System. Automatic Reclosing is included in the PSMP because it is a more pragmatic approach as compared to creating a parallel and essentially identical 'Control System Maintenance Program' for the ~~two~~ Automatic Reclosing component types.

When do I need to have the initial maintenance of Automatic Reclosing Components completed upon change of the largest BES generating unit in the BA/RSG?

The maintenance interval, for newly identified Automatic Reclosing Components, starts when a change in the largest BES generating unit is determined by the BA/RSG. The first maintenance records for newly identified Automatic Reclosing Components should be dated no later than the maximum maintenance interval after the identification date. The maximum maintenance intervals for each newly identified Component are defined in Table 4. No activities or records are required prior to the date of identification.

Our maintenance practice consists of initiating the Automatic Reclosing relay and confirming the breaker closes properly and the close signal is released. This practice verifies the control circuitry associated with Automatic Reclosing. Do you agree?"

The described task partially verifies the control circuit maintenance activity. To meet the control circuit maintenance activity, responsible entities need to verify, *upon initiation*, that the reclosing relay does not issue a *premature closing command*. As noted on page 12 of the SAMS/SPCS report, the concern being addressed within the standard is premature auto reclosing that has the potential to cause generating unit or plant instability. Reclosing applications have many variations, responsible entities will need to verify the applicability of associated supervision/conditional logic and the reclosing relay operation; then verify the conditional logic or that the reclosing relay performs in a manner that does not result in a *premature closing command* being issued.

Some examples of conditions which can result in a premature closing command are: an improper supervision or conditional logic input which provides a false state and allows the reclosing relay to issue an improper close command based on incorrect conditions (i.e. voltage supervision, equipment status, sync window verification); timers utilized for closing actuation or reclosing arming/disarming circuitry which could allow the reclosing relay to issue an improper close command; a reclosing relay output contact failure which could result in a made-up-close condition / failure-to-release condition.

Why was a close-in three phase fault present for twice the normal clearing time chosen for the Automatic Reclosing exclusion? It exceeds TPL requirements and ignores the breaker closing time in a trip-close-trip sequence, thus making the exclusion harder to attain.

This condition represents a situation where a close signal is issued with no time delay or with less time delay than is intended, such as if a reclosing contact is welded closed. This failure mode can result in a minimum trip-close-trip sequence with the two faults cleared in primary protection operating time, and the open time between faults equal to the breaker closing cycle time. The sequence for this failure mode results in system impact equivalent to a high-speed autoreclosing sequence with no delay added in the autoreclosing logic. It represents a failure mode which must be avoided because it exceeds TPL requirements.

Do we have to test the various breaker closing circuit interlocks and controls such as anti-pump?

These components are not specifically addressed within Table 4, and need not be individually tested. ~~They are indirectly verified by performing the Automatic Reclosing control circuitry verification as established in Table 4.~~

For Automatic Reclosing that is not part of an RAS, do we have to close the circuit breaker periodically?

No. ~~F--for~~For this application, you need only to verify that the Automatic Reclosing, upon initiation, does not issue a premature closing command. This activity is concerned only with assuring that a premature close does not occur, and cause generating plant instability.

For Automatic Reclosing that is part of an RAS, do we have to close the circuit breaker periodically?

Yes. ~~I--in~~In this application, successful closing is a necessary portion of the RAS, and must be verified.

Why is maintenance of supervisory relays now included in PRC-005 for Automatic Reclosing?

Proper performance of supervising relays supports the reliability of the BES because some conditions can result in a premature closing command. -An example of this would be an improper supervision or conditional logic input which provides a false state and allows the reclosing relay to issue an improper close command based on incorrect conditions (i.e. voltage supervision, sync window verification)

My reclosing circuitry contains the following inputs listed below. Which parts of the control circuitry would need to be verified, upon initiation, do not issue a premature close command per PRC-005? My reclosing circuitry contains the following inputs listed below; what supervising relays would need to be tested per PRC-005?:

- 79/ON – Supervisory contact which turns Automatic Reclosing ON or OFF
- 52 – Supervisory contact which provides breaker indication (“b” contact)
- 86 - Supervisory contact from a lockout relay
- 79 – Supervisory contact from a reclosing relay
- 25 – Supervisory contact from a sync-check relay
- 27 or 59 – Supervisory contact from an undervoltage or overvoltage relay

Supervisory Relays are defined in this standard as “relay(s) that perform voltage and/or sync check functions that enables or disables operation of the reclosing relay.” The 79, 25, and 27 or 59 would need to be verified because they are supervisory devices that are associated with Automatic Reclosing. The 79/ON, 52, and 86 would not need to be included. However, the 79/ON, 52, and 86 would not need to be verified. 79, 25, and 27 or 59 would be included because they are supervisory devices that are either associated with autoreclosing, sync checks, and/or voltage.

The sync check and voltage check functions are part of my microprocessor reclosing relay. Are there any test requirements for these internal supervisory functions?

A microprocessor reclosing relay that is using internal sync check or voltage check supervisory functions is a combinational reclosing and supervisory relay (i.e. 79/25).-. The maintenance activities for both a reclosing relay and supervisory relay would apply. The voltage sensing devices providing input to a combinational reclosing and supervisory relay would require the activities in Table 4-3.

Is it necessary to verify the close signal operates the breaker?

Only when the control circuitry associated with automatic reclosing is a part of a RAS, then all paths that are essential for proper operation of the RAS must be verified, per table 4-2(b).

15.9 Sudden Pressure Relaying (Table 5)

Please see the document referenced in Section F of PRC-005-4-6, “Sudden Pressure Relays and Other Devices that Respond to Non-Electrical Quantities – December 2013”, for a discussion of Sudden Pressure Relaying as addressed in PRC-005-4-6.

15.9.1 Frequently Asked Questions:

How do I verify the pressure or flow sensing mechanism is operable?

Maintenance activities for the fault pressure relay associated with Sudden Pressure Relaying in PRC-005-4-6 are intended to verify that the pressure and/or flow sensing mechanism are functioning correctly. Beyond this, PRC-005-4-6 requires no calibration (adjusting the operating threshold or measurement accuracy of a measuring element to meet the intended performance requirement) or testing (applying signals to a component to observe functional performance or output behavior, or to diagnose problems) activities. For example, some designs of flow sensing mechanisms allow the operation of a test switch to actuate the limit switch of the flow sensing mechanism. Operation of this test switch and verification of the flow sensing mechanism would meet the requirements of the maintenance activity. Another example involves a gas pressure sensing mechanism which is isolated by a test plug. Removal of the plug and verification of the bellows mechanism would meet the requirements of the maintenance activity.

Why the 6-year maximum maintenance interval for fault pressure relays?

The SDT established the six-year maintenance interval for fault pressure relays (see Table 5, PRC-005-4-6) based on the recommendation of the System Protection and Control Subcommittee (SPCS). The technical experts of the SPCS were tasked with developing the technical documents to:

- i. Describe the devices and functions (to include sudden pressure relays which trip for fault conditions) that should address FERC’s concern; and
- ii. Propose minimum maintenance activities for such devices and maximum maintenance intervals, including the technical basis for each.

Excerpt from the [SPCS technical report](#): “In order to determine present industry practices related to sudden pressure relay maintenance, the SPCS conducted a survey of Transmission Owners and Generator Owners in all eight Regions requesting information related to their maintenance practices. The SPCS received responses from 75 Transmission Owners and 109 Generator Owners. Note that, for the purpose of the survey, sudden pressure relays included the following: the “sudden pressure relay” (SPR) originally manufactured by Westinghouse, the “rapid pressure rise relay” (RPR) manufactured by Qualitrol, and a variety of Buchholz relays.

Table 2 provides a summary of the results of the responses:

Table 2: Sudden Pressure Relay Maintenance Practices – Survey Results		
	Transmission Owner	Generator Owner
Number of responding owners that trip with Sudden Pressure Relays:	67	84
Percentage of responding owners who trip that have a Maintenance Program:	75%	78%
Percentage of maintenance programs that include testing the pressure actuator:	81%	77%
Average Maintenance interval reported:	5.9 years	4.9 years

Additionally, in order to validate the information noted above, the SPCS contacted the following entities for their feedback: the IEEE Power System Relaying Committee, the IEEE Transformer Committee, the Doble Transformer Committee, the NATF System Protection Practices Group, and the EPRI Generator Owner/Operator Technical Focus Group. All of these organizations indicated the results of the SPCS survey are consistent with their respective experiences.

The SPCS discussed the potential difference between the recommended intervals for fault pressure relaying and intervals for transformer maintenance. The SPCS developed the recommended intervals for fault pressure relaying by comparing fault pressure relaying to Protection System Components with similar physical attributes. The SPCS recognized that these intervals may be shorter than some existing or future transformer maintenance intervals, but believed it to be more important to base intervals for fault pressure relaying on similar Protection System Components than transformer maintenance intervals.

The maintenance interval for fault pressure relays can be extended by utilizing performance-based maintenance thereby allowing entities that have maintenance intervals for transformers in excess of six years, to align them.

Sudden Pressure Relaying control circuitry is now specifically mentioned in the maintenance tables. Do we have to trip our circuit breaker specifically from the trip output of the sudden pressure relay?

No. ~~V--verification~~Verification may be by breaker tripping, but may be verified in overlapping segments with the Protection System control circuitry.

Can we use Performance Based Maintenance for fault pressure relays?

Yes. ~~P--performance~~Performance Based Maintenance is applicable to fault pressure relays.

15.10 Examples of Evidence of Compliance

To comply with the requirements of this standard, an entity will have to document and save evidence. The evidence can be of many different forms. The Standard Drafting Team recognizes that there are concurrent evidence requirements of other NERC standards that could, at times, fulfill evidence requirements of this standard.

15.10.1 Frequently Asked Questions:

What forms of evidence are acceptable?

Acceptable forms of evidence, as relevant for the requirement being documented include, but are not limited to:

- Process documents or plans
- Data (such as relay settings sheets, photos, SCADA, and test records)
- Database lists, records and/or screen shots that demonstrate compliance information
- Prints, diagrams and/or schematics
- Maintenance records
- Logs (operator, substation, and other types of log)
- Inspection forms
- Mail, memos, or email proving the required information was exchanged, coordinated, submitted or received
- Check-off forms (paper or electronic)
- Any record that demonstrates that the maintenance activity was known, accounted for, and/or performed.

If I replace a failed Protection System component with another component, what testing do I need to perform on the new component?

In order to reset the Table 1 maintenance interval for the replacement component, all relevant Table 1 activities for the component should be performed.

I have evidence to show compliance for PRC-016 ("Special Protection System Misoperation"). Can I also use it to show compliance for this Standard, PRC-005-4-6?

Maintaining evidence for operation of Remedial Action Schemes could concurrently be utilized as proof of the operation of the associated trip coil (provided one can be certain of the trip coil involved). Thus, the reporting requirements that one may have to do for the Misoperation of a Special Protection Scheme under PRC-016 could work for the activity tracking requirements under this PRC-005-4-6.

I maintain Disturbance records which show Protection System operations. Can I use these records to show compliance?

These records can be concurrently utilized as dc trip path verifications, to the degree that they demonstrate the proper function of that dc trip path.

I maintain test reports on some of my Protection System components. Can I use these test reports to show that I have verified a maintenance activity?

~~Yes.~~Yes—the test reports may be used to demonstrate a verified maintenance activity.~~Yes.~~

References

1. [Protection System Maintenance: A Technical Reference](#). Prepared by the System Protection and Controls Task Force of the NERC Planning Committee. Dated September 13, 2007.
2. "Predicating The Optimum Routine test Interval For Protection Relays," by J. J. Kumm, M.S. Weber, D. Hou, and E. O. Schweitzer, III, IEEE Transactions on Power Delivery, Vol. 10, No. 2, April 1995.
3. "Transmission Relay System Performance Comparison For 2000, 2001, 2002, 2003, 2004 and 2005," Working Group I17 of Power System Relaying Committee of IEEE Power Engineering Society, May 2006.
4. "A Survey of Relaying Test Practices," Special Report by WG I11 of Power System Relaying Committee of IEEE Power Engineering Society, September 16, 1999.
5. "Transmission Protective Relay System Performance Measuring Methodology," Working Group I3 of Power System Relaying Committee of IEEE Power Engineering Society, January 2002.
6. "Processes, Issues, Trends and Quality Control of Relay Settings," Working Group C3 of Power System Relaying Committee of IEEE Power Engineering Society, December 2006.
7. "Proposed Statistical Performance Measures for Microprocessor-Based Transmission-Line Protective Relays, Part I - Explanation of the Statistics, and Part II - Collection and Uses of Data," Working Group D5 of Power System Relaying Committee of IEEE Power Engineering Society, May 1995; Papers 96WM 016-6 PWRD and 96WM 127-1 PWRD, 1996 IEEE Power Engineering Society Winter Meeting.
8. "Analysis And Guidelines For Testing Numerical Protection Schemes," Final Report of CIGRE WG 34.10, August 2000.
9. "Use of Preventative Maintenance and System Performance Data to Optimize Scheduled Maintenance Intervals," H. Anderson, R. Loughlin, and J. Zipp, Georgia Tech Protective Relay Conference, May 1996.
10. "Battery Performance Monitoring by Internal Ohmic Measurements" EPRI Application Guidelines for Stationary Batteries TR- 108826 Final Report, December 1997.
11. "IEEE Recommended Practice for Maintenance, Testing, and Replacement of Valve-Regulated Lead-Acid (VRLA) Batteries for Stationary Applications," IEEE Power Engineering Society Std 1188 – 2005.
12. "IEEE Recommended Practice for Maintenance, Testing, and Replacement of Vented Lead-Acid Batteries for Stationary Applications," IEEE Power & Engineering Society Std 45-2010.
13. "IEEE Recommended Practice for Installation design and Installation of Vented Lead-Acid Batteries for Stationary Applications," IEEE Std 484 – 2002.
14. "Stationary Battery Monitoring by Internal Ohmic Measurements," EPRI Technical Report, 1002925 Final Report, December 2002.

15. "Stationary Battery Guide: Design Application, and Maintenance" EPRI Revision 2 of TR-100248, 1006757, August 2002.

PSMT SDT References

16. "Essentials of Statistics for Business and Economics" Anderson, Sweeney, Williams, 2003
17. "Introduction to Statistics and Data Analysis" - Second Edition, Peck, Olson, Devore, 2005
18. "Statistical Analysis for Business Decisions" Peters, Summers, 1968
19. "Considerations for Maintenance and Testing of Autoreclosing Schemes," NERC System Analysis and Modeling Subcommittee and NERC System Protection and Control Subcommittee, November 2012

Figures

Figure 1: Typical Transmission System

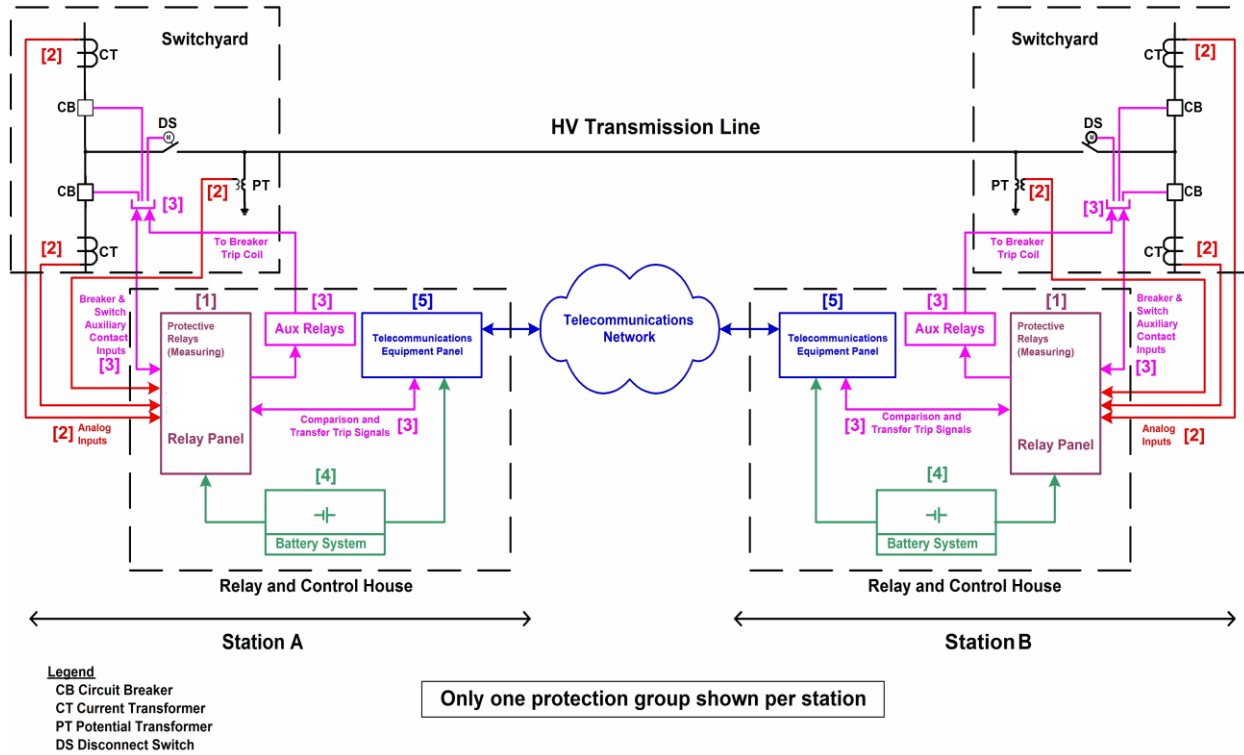

For information on components, see [Figure 1 & 2 Legend – components of Protection Systems](#)

Figure 1 & 2 Legend – Components of Protection Systems

Number in Figure	Component of Protection System	Includes	Excludes
1	Protective relays which respond to electrical quantities	All protective relays that use current and/or voltage inputs from current & voltage sensors and that trip the 86, 94 or trip coil.	Devices that use non-electrical methods of operation including thermal, pressure, gas accumulation, and vibration. Any ancillary equipment not specified in the definition of Protection Systems. Control and/or monitoring equipment that is not a part of the automatic tripping action of the Protection System
2	Voltage and current sensing devices providing inputs to protective relays	The signals from the voltage & current sensing devices to the protective relay input.	Voltage & current sensing devices that are not a part of the Protection System, including sync-check systems, metering systems and data acquisition systems.
3	Control circuitry associated with protective functions	All control wiring (or other medium for conveying trip signals) associated with the tripping action of 86 devices, 94 devices or trip coils (from all parallel trip paths). This would include fiber-optic systems that carry a trip signal as well as hard-wired systems that carry trip current.	Closing circuits, SCADA circuits, other devices in control scheme not passing trip current
4	Station dc supply	Batteries and battery chargers and any control power system which has the function of supplying power to the protective relays, associated trip circuits and trip coils.	Any power supplies that are not used to power protective relays or their associated trip circuits and trip coils.
5	Communications systems necessary for correct operation of protective functions	Tele-protection equipment used to convey specific information, in the form of analog or digital signals, necessary for the correct operation of protective functions.	Any communications equipment that is not used to convey information necessary for the correct operation of protective functions.

[Additional information can be found in References](#)

Appendix A

The following illustrates the concept of overlapping verifications and tests as summarized in Section 10 of the paper. As an example, Figure A-1 shows protection for a critical transmission line by carrier blocking directional comparison pilot relaying. The goal is to verify the ability of the entire two-terminal pilot protection scheme to protect for line faults, and to avoid over-tripping for faults external to the transmission line zone of protection bounded by the current transformer locations.

Figure A-1

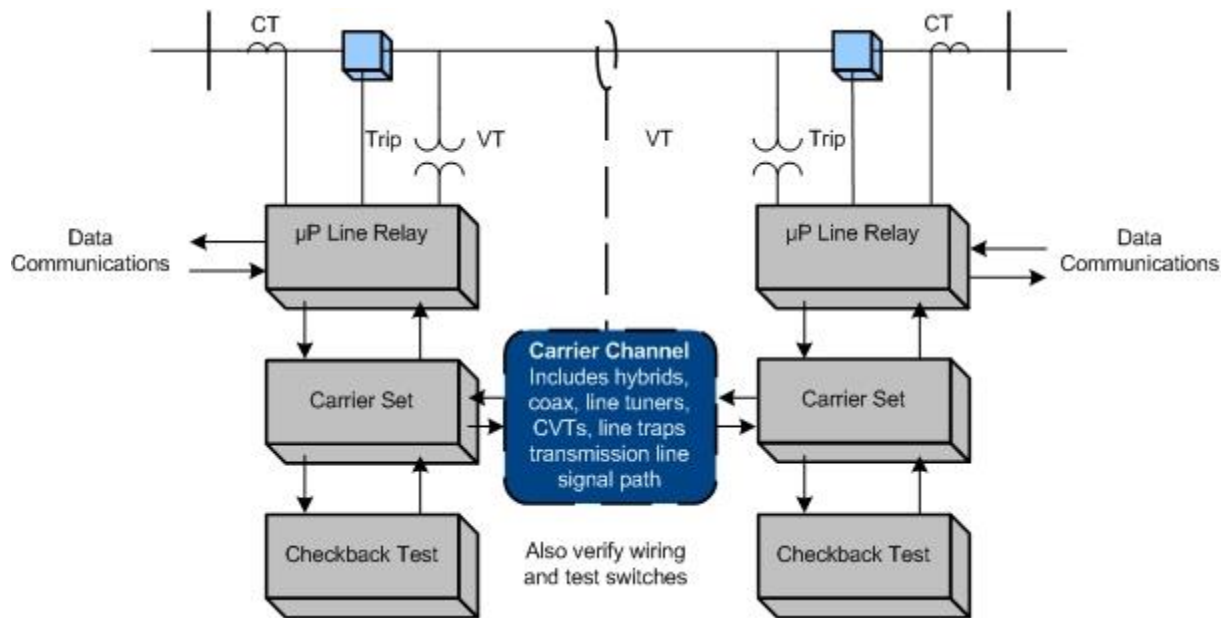

In this example (Figure A1), verification takes advantage of the self-monitoring features of microprocessor multifunction line relays at each end of the line. For each of the line relays themselves, the example assumes that the user has the following arrangements in place:

1. The relay has a data communications port that can be accessed from remote locations.
2. The relay has internal self-monitoring programs and functions that report failures of internal electronics, via communications messages or alarm contacts to SCADA.
3. The relays report loss of dc power, and the relays themselves or external monitors report the state of the dc battery supply.
4. The CT and PT inputs to the relays are used for continuous calculation of metered values of volts, amperes, plus Watts and ~~VARs~~ vars on the line. These metered values are reported by data communications. For maintenance, the user elects to compare these readings to those of other relays, meters, or DFRs. The other readings may be from redundant relaying or measurement systems or they may be derived from values in other protection zones. Comparison with other such readings to within required relaying accuracy verifies voltage & and current sensing devices, wiring, and analog signal input processing of the relays. One effective way to do this is to utilize the relay metered values directly in SCADA, where they can be compared with other references or state estimator values.

5. Breaker status indication from auxiliary contacts is verified in the same way as in (2). Status indications must be consistent with the flow or absence of current.
6. Continuity of the breaker trip circuit from dc bus through the trip coil is monitored by the relay and reported via communications.
7. Correct operation of the on-off carrier channel is also critical to security of the Protection System, so each carrier set has a connected or integrated automatic checkback test unit. The automatic checkback test runs several times a day. Newer carrier sets with integrated checkback testing check for received signal level and report abnormal channel attenuation or noise, even if the problem is not severe enough to completely disable the channel.

These monitoring activities plus the check-back test comprise automatic verification of all the Protection System elements that experience tells us are the most prone to fail. But, does this comprise a complete verification?

Figure A-2

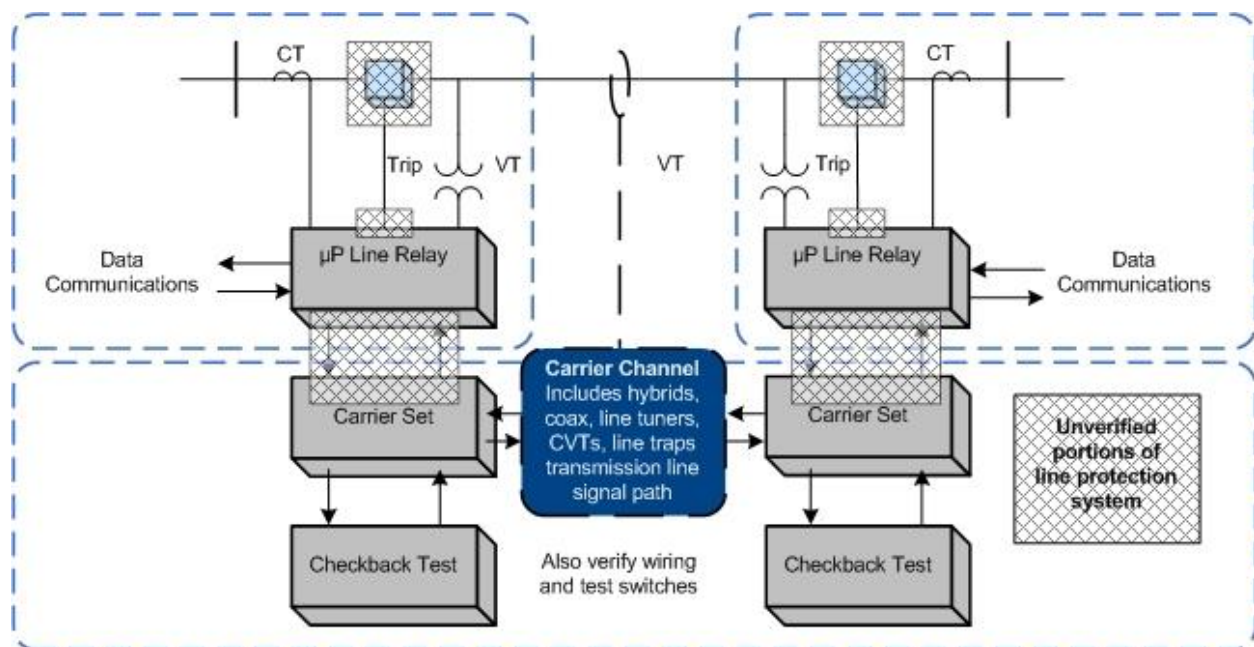

The dotted boxes of Figure A-2 show the sections of verification defined by the monitoring and verification practices just listed. These sections are not completely overlapping, and the shaded regions show elements that are not verified:

1. The continuity of trip coils is verified, but no means is provided for validating the ability of the circuit breaker to trip if the trip coil should be energized.

-
2. Within each line relay, all the microprocessors that participate in the trip decision have been verified by internal monitoring. However, the trip circuit is actually energized by the contacts of a small telephone-type "ice cube" relay within the line protective relay. The microprocessor energizes the coil of this ice cube relay through its output data port and a transistor driver circuit. There is no monitoring of the output port, driver circuit, ice cube relay, or contacts of that relay. These components are critical for tripping the circuit breaker for a Fault.
 3. The check-back test of the carrier channel does not verify the connections between the relaying microprocessor internal decision programs and the carrier transmitter keying circuit or the carrier receiver output state. These connections include microprocessor I/O ports, electronic driver circuits, wiring, and sometimes telephone-type auxiliary relays.
 4. The correct states of breaker and disconnect switch auxiliary contacts are monitored, but this does not confirm that the state change indication is correct when the breaker or switch opens.

A practical solution for (1) and (2) is to observe actual breaker tripping, with a specified maximum time interval between trip tests. Clearing of naturally-occurring Faults are demonstrations of operation that reset the time interval clock for testing of each breaker tripped in this way. If Faults do not occur, manual tripping of the breaker through the relay trip output via data communications to the relay microprocessor meets the requirement for periodic testing.

PRC-005-~~4-6~~ does not address breaker maintenance, and its Protection System test requirements can be met by energizing the trip circuit in a test mode (breaker disconnected) through the relay microprocessor. This can be done via a front-panel button command to the relay logic, or application of a simulated Fault with a relay test set. However, utilities have found that breakers often show problems during Protection System tests. It is recommended that Protection System verification include periodic testing of the actual tripping of connected circuit breakers.

Testing of the relay-carrier set interface in (3) requires that each relay key its transmitter, and that the other relay demonstrate reception of that blocking carrier. This can be observed from relay or DFR records during naturally occurring Faults, or by a manual test. If the checkback test sequence were incorporated in the relay logic, the carrier sets and carrier channel are then included in the overlapping segments monitored by the two relays, and the monitoring gap is completely eliminated.

Appendix B

Protection System Maintenance Standard Drafting Team

Charles W. Rogers

Chairman

Consumers Energy Co.

John B. Anderson

Xcel Energy

Stephen Crutchfield

NERC

Forrest Brock

Western Farmers Electric Cooperative

John Schecter

American Electric Power

Aaron Feathers

Pacific Gas and Electric Company

William D. Shultz

Southern Company Generation

Sam Francis

Oncor Electric Delivery

Scott Vaughan

City of Roseville Electric Department

Matthew Westrich

American Transmission Company

James M. Kinney

FirstEnergy Corporation

Philip B. Winston

Southern Company Transmission

Kristina Marriott

ENOSERV

Appendix B

Protection System Maintenance Standard Drafting Team

~~Charles W. Rogers~~

~~Chairman~~

~~Consumers Energy Co.~~

Charles W. Rogers - Chairman Consumers Energy Co.	John Schecter American Electric Power
John B. Anderson Xcel Energy	Stephen Crutchfield NERC Southern Company Generation
Kristina Marriott ENOSERV Tri-State G&T	Al McMeekin William D. Shultz Scott Vaughan City of Roseville Electric Department Palusso Southern California Edison
Forrest Brock Western Farmers Electric Cooperative	Matthew Westrich American Transmission Company
Aaron Feathers Pacific Gas and Electric Company	Philip B. Winston Southern Company Transmission
James M. Kinney FirstEnergy Corporation	Stephen Crutchfield NERC

Charles W. Rogers - Chairman

<u>Consumers Energy Co.</u>	John Schecter American Electric Power
Aaron Feathers Pacific Gas and Electric Company <u>John B. Anderson Xcel Energy</u>	William D. Shultz Southern Company Generation
Sam Francis Oncor Electric Delivery	Eric A. Udren Quanta Technology
David Harper NRG Texas Maintenance Services Kristina Marriott ENOSERV	Scott Vaughan City of Roseville Electric Department
James M. Kinney FirstEnergy Corporation <u>Forrest Brock Western Farmers Electric Cooperative</u>	Matthew Westrich American Transmission Company
Mark Lucas ComEd Aaron Feathers Pacific Gas and Electric Company	Philip B. Winston Southern Company Transmission
Sam Francis	

Oncor Electric Delivery	
Kristina Marriott	Stephen Crutchfield
ENOSERV James M. Kinney	John A. Zipp
FirstEnergy Corporation	ITC Holdings NERC

Consideration of Directives

Project 2007-17.4 – PRC-005 Order 803 Directive

July 14, 2015

Project 2007-17.4 – PRC-005 Order 803 Directive

Issue or Directive	Source	Consideration of Issue or Directive
<p>In Order No. 803, FERC approved Standard PRC-005-3 and, in Paragraph 31, directed NERC to:</p> <p>"...direct that, pursuant to section 215(d)(5) of the FPA, NERC develop modifications to PRC-005-3 to include supervisory devices associated with auto-reclosing relay schemes to which the Reliability Standard applies. Further, we clarify that NERC's proposal regarding the scope of supervisory devices is an acceptable approach to satisfy the Commission directive. Specifically, NERC proposed in its NOPR comments, and we find acceptable, that the scope of the supervisory devices to be encompassed in the Reliability Standard are those providing voltage supervision, supervisory inputs associated with selective auto-reclosing, and sync-check relays that are part of a reclosing scheme covered by PRC-005-3."</p>	<p>FERC Order 803 approving Reliability Standard PRC-005-3, Protection System, Automatic Reclosing, and Sudden Pressure Relaying Maintenance</p>	<p>The Protection System Maintenance and Testing Standard Drafting Team (PSMTSDT) proposed revision of the standard specific defined terms "Automatic Reclosing" and "Component Type" as follows:</p> <p>Automatic Reclosing – Includes the following Components:</p> <ul style="list-style-type: none"> • Reclosing relay • Supervisory relay(s) or function(s)– relay(s) or function(s) that perform voltage and/or sync check functions that enables or disables operation of the reclosing relay • Voltage sensing devices associated with the supervisory relay(s) • Control circuitry associated with the reclosing relay or supervisory relay(s) <p>Component Type –</p>

Project 2007-17.4 – PRC-005 Order 803 Directive

Issue or Directive	Source	Consideration of Issue or Directive
		<ul style="list-style-type: none"> • Any one of the five specific elements of a Protection System. • Any one of the four specific elements of Automatic Reclosing. • Any one of the two specific elements of Sudden Pressure Relaying. <p>The Rationales for “Automatic Relaying” and “Component Type” were also revised to reflect the proposed revisions to the defined terms above. Tables 4-1 and 4-2 were updated by adding “supervisory relay(s)” as appropriate. A new Table 4-3 was added to address maintenance activities and intervals for Automatic Reclosing with supervisory relays. No substantive revisions are being proposed for the Requirements of the standard. The only revisions to Requirements R1 and R3 included updating the Table numbering to reflect the addition of Table 4-3. The Violation Severity Levels (VSLs) were updated to reflect the Requirement language for R1 and R3. All references to table numbering throughout the standard have also been corrected to reflect the addition of Table 4-3. This version of PRC-005 used PRC-005-5 developed under Project 2014-01 as the starting point for revisions to address the directive.</p>

Standards Announcement **Reminder**

Project 2007-17.4 FERC Order No. 803 Directive
PRC-005-6

Initial Ballot and Non-binding Poll Open through September 16, 2015

[Now Available](#)

An initial ballot for draft one of **PRC-005-6 – Protection System, Automatic Reclosing, and Sudden Pressure Relaying Maintenance** and a non-binding poll of the associated Violation Risk Factors (VRFs) and Violation Severity Levels (VSLs) are open through **8 p.m. Eastern, Wednesday, September 16, 2015.**

Balloting

Members of the ballot pools associated with this project may log in and submit their votes for the standard and associated VRFs and VSLs by clicking [here](#).

If you are having difficulty accessing the SBS due to a forgotten password, incorrect credential error messages, or system lock-out, contact NERC IT support directly at EROhelpdesk@nerc.net (Monday – Friday, 8 a.m. - 8 p.m. Eastern).

Next Steps

The ballot results will be announced and posted on the project page. The drafting team will consider all comments received during the formal comment period and, if needed, make revisions to the standard and post it for an additional ballot. If the comments do not show the need for significant revisions, the standard will proceed to a final ballot.

Standards Development Process

For more information on the Standards Development Process, refer to the [Standard Processes Manual](#).

For more information or assistance, contact Senior Standards Developer, [Stephen Crutchfield](#) (via email), or at (609) 651-9455.

North American Electric Reliability Corporation

3353 Peachtree Rd, NE

Suite 600, North Tower

Atlanta, GA 30326

404-446-2560 | www.nerc.com

Standards Announcement

Project 2007-17.4 FERC Order No. 803 Directive PRC-005-6

Formal Comment Period Open through September 16, 2015
Ballot Pools Being Formed through August 28, 2015

[Now Available](#)

A 45-day formal comment period for draft one of **PRC-005-6 – Protection System, Automatic Reclosing, and Sudden Pressure Relaying Maintenance** is open through **8 p.m. Eastern, Wednesday, September 16, 2015**.

Commenting

Use the [electronic form](#) to submit comments on the standard. If you experience any difficulties in using the electronic form, contact [Wendy Muller](#). An unofficial Word version of the comment form is posted on the [project page](#).

Join the Ballot Pools

Ballot pools are being formed through **8 p.m. Eastern, Friday, August 28, 2015**. Registered Ballot Body members may join the ballot pools [here](#).

Next Steps

An initial ballot for the standard and a non-binding poll of the associated Violation Risk Factors and Violation Severity Levels will be conducted **September 4-16, 2015**.

Standards Development Process

For more information on the Standards Development Process, refer to the [Standard Processes Manual](#).

For more information or assistance, contact Senior Standards Developer, [Stephen Crutchfield](#) (via email), or at (609) 651-9455.

North American Electric Reliability Corporation

3353 Peachtree Rd, NE

Suite 600, North Tower

Atlanta, GA 30326

404-446-2560 | www.nerc.com

Standards Announcement

Project 2007-17.4 FERC Order No. 803 Directive PRC-005-6

Formal Comment Period Open through September 16, 2015
Ballot Pools Being Formed through August 28, 2015

[Now Available](#)

A 45-day formal comment period for draft one of **PRC-005-6 – Protection System, Automatic Reclosing, and Sudden Pressure Relaying Maintenance** is open through **8 p.m. Eastern, Wednesday, September 16, 2015**.

Commenting

Use the [electronic form](#) to submit comments on the standard. If you experience any difficulties in using the electronic form, contact [Wendy Muller](#). An unofficial Word version of the comment form is posted on the [project page](#).

Join the Ballot Pools

Ballot pools are being formed through **8 p.m. Eastern, Friday, August 28, 2015**. Registered Ballot Body members may join the ballot pools [here](#).

Next Steps

An initial ballot for the standard and a non-binding poll of the associated Violation Risk Factors and Violation Severity Levels will be conducted **September 4-16, 2015**.

Standards Development Process

For more information on the Standards Development Process, refer to the [Standard Processes Manual](#).

For more information or assistance, contact Senior Standards Developer, [Stephen Crutchfield](#) (via email), or at (609) 651-9455.

North American Electric Reliability Corporation
3353 Peachtree Rd, NE
Suite 600, North Tower
Atlanta, GA 30326
404-446-2560 | www.nerc.com

Standards Announcement

Project 2007-17.4 FERC Order No. 803 Directive
PRC-005-6

Draft RSAW Posted for Industry Comment through September 16, 2015

Now Available

The draft RSAW for **PRC-005-6 – Protection System, Automatic Reclosing, and Sudden Pressure Relaying Maintenance** is posted on the [project page](#) for industry comment through **8 p.m. Eastern, Wednesday, September 16, 2015**. Submit feedback regarding the draft RSAW to RSAWfeedback@nerc.net.

For more information or assistance, contact Senior Standards Developer, [Stephen Crutchfield](#) (via email), or at (609) 651-9455.

North American Electric Reliability Corporation

3353 Peachtree Rd, NE

Suite 600, North Tower

Atlanta, GA 30326

404-446-2560 | www.nerc.com

Standards Announcement

Project 2007-17.4 FERC Order No. 803 Directive
PRC-005-6

Initial Ballot and Non-binding Poll Results

[Now Available](#)

A 45-day formal comment period and initial ballot for draft one of **PRC-005-6 – Protection System, Automatic Reclosing, and Sudden Pressure Relaying Maintenance** as well as a non-binding poll of the associated Violation Risk Factors and Violation Severity Levels concluded **8 p.m. Eastern, Wednesday, September 16, 2015.**

The initial ballot received sufficient affirmative votes for approval. Voting statistics are listed below, and the [Ballot Results](#) page provides detailed results for the ballot and non-binding poll.

Ballot	Non-binding Poll
Quorum /Approval	Quorum/Supportive Opinions
86.97% / 96.73%	84.69% / 96.46%

Next Steps

The drafting team will consider all comments received during the formal comment period and determine the next steps for the project.

Standards Development Process

For more information on the Standards Development Process, refer to the [Standard Processes Manual](#).

For more information or assistance, contact Senior Standards Developer, [Stephen Crutchfield](#) (via email), or at (609) 651-9455.

North American Electric Reliability Corporation

3353 Peachtree Rd, NE

Suite 600, North Tower

Atlanta, GA 30326

404-446-2560 | www.nerc.com

NERC Balloting Tool (/)

[Dashboard \(/\)](#)
[Users](#)
[Ballots](#)
[Surveys](#)
[Legacy SBS \(https://standards.nerc.net/\)](#)
[Login \(/Users/Login\)](#) / [Register \(/Users/Register\)](#)

BALLOT RESULTS

Survey: [View Survey Results \(/SurveyResults/Index/24\)](#)

Ballot Name: 2007-17.4 PRC-005 FERC Order No. 803 Directive PRC-005-6 IN 1 ST

Voting Start Date: 9/4/2015 12:01:00 AM

Voting End Date: 9/16/2015 8:00:00 PM

Ballot Type: ST

Ballot Activity: IN

Ballot Series: 1

Total # Votes: 287

Total Ballot Pool: 330

Quorum: 86.97

Weighted Segment Value: 96.73

Segment	Ballot Pool	Segment Weight	Affirmative Votes	Affirmative Fraction	Negative Votes w/ Comment	Negative Fraction w/ Comment	Negative Votes w/o Comment	Abstain	No Vote
Segment: 1	81	1	62	0.969	2	0.031	0	6	11
Segment: 2	8	0.4	4	0.4	0	0	0	2	2
Segment: 3	76	1	54	0.964	2	0.036	0	9	11
Segment: 4	26	1	20	0.952	1	0.048	0	0	5
Segment: 5	80	1	59	0.952	3	0.048	0	8	10
Segment: 6	45	1	36	0.947	2	0.053	0	3	4
Segment: 7	2	0.1	1	0.1	0	0	0	1	0
Segment: 8	2	0.2	2	0.2	0	0	0	0	0
Segment:	2	0.2	2	0.2	0	0	0	0	0

9									
Segment: 10	8	0.7	7	0.7	0	0	0	1	0
Totals:	330	6.6	247	6.384	10	0.216	0	30	43

BALLOT POOL MEMBERS

Show entries

Search:

Segment	Organization	Voter	Designated Proxy	Ballot	NERC Memo
1	Ameren - Ameren Services	Eric Scott		Affirmative	N/A
1	American Transmission Company, LLC	Andrew Puszta		Affirmative	N/A
1	APS - Arizona Public Service Co.	Michelle Amarantos		Abstain	N/A
1	Associated Electric Cooperative, Inc.	Phil Hart		Affirmative	N/A
1	Avista - Avista Corporation	Bryan Cox	Rich Hydzik	Affirmative	N/A
1	Balancing Authority of Northern California	Kevin Smith	Joe Tarantino	Affirmative	N/A
1	BC Hydro and Power Authority	Patricia Robertson		Abstain	N/A
1	Beaches Energy Services	Don Cuevas		Affirmative	N/A
1	Berkshire Hathaway Energy - MidAmerican Energy Co.	Terry Harbour		Affirmative	N/A

1	Black Hills Corporation	Wes Wingen		Abstain	N/A
1	Bonneville Power Administration	Donald Watkins		Affirmative	N/A
1	Brazos Electric Power Cooperative, Inc.	Tony Kroskey		None	N/A
1	Bryan Texas Utilities	John Fontenot		Affirmative	N/A
1	CenterPoint Energy Houston Electric, LLC	John Brockhan		Affirmative	N/A
1	Central Electric Power Cooperative (Missouri)	Michael Bax		None	N/A
1	Cleco Corporation	John Lindsey	Louis Guidry	Affirmative	N/A
1	Colorado Springs Utilities	Shawna Speer		None	N/A
1	Con Ed - Consolidated Edison Co. of New York	Chris de Graffenried		Affirmative	N/A
1	Dairyland Power Cooperative	Robert Roddy		Affirmative	N/A
1	Dominion - Dominion Virginia Power	Larry Nash		Affirmative	N/A
1	Duke Energy	Doug Hils		Affirmative	N/A
1	East Kentucky Power Cooperative	Amber Skillern		Affirmative	N/A
1	Edison International - Southern California Edison Company	Steven Mavis		Affirmative	N/A
1	Entergy - Entergy Services, Inc.	Oliver Burke		Affirmative	N/A
1	Exelon	Chris Scanlon		Affirmative	N/A
1	FirstEnergy - FirstEnergy Corporation	William Smith		Affirmative	N/A
1	Georgia	Jason Snodgrass		Affirmative	N/A

	Transmission Corporation				
1	Great Plains Energy - Kansas City Power and Light Co.	James McBee	Douglas Webb	Affirmative	N/A
1	Great River Energy	Gordon Pietsch		Affirmative	N/A
1	Hoosier Energy Rural Electric Cooperative, Inc.	Bob Solomon		None	N/A
1	Hydro One Networks, Inc.	Payam Farahbakhsh	Oshani Pathirane	Affirmative	N/A
1	Hydro-Québec TransEnergie	Martin Boisvert		Affirmative	N/A
1	IDACORP - Idaho Power Company	Molly Devine		Affirmative	N/A
1	International Transmission Company Holdings Corporation	Michael Moltane	Meghan Ferguson	Affirmative	N/A
1	KAMO Electric Cooperative	Walter Kenyon		Affirmative	N/A
1	Los Angeles Department of Water and Power	faranak sarbaz		Affirmative	N/A
1	Lower Colorado River Authority	Teresa Cantwell		Affirmative	N/A
1	M and A Electric Power Cooperative	William Price		Affirmative	N/A
1	Manitoba Hydro	Mike Smith		Negative	Comments Submitted
1	MEAG Power	David Weekley	Scott Miller	None	N/A
1	Muscatine Power and Water	Andy Kurriger		Affirmative	N/A
1	N.W. Electric Power Cooperative, Inc.	Mark Ramsey		Affirmative	N/A
1	National Grid USA	Michael Jones		Affirmative	N/A
1	NB Power	Alan MacNaughton		None	N/A

	Corporation				
1	Nebraska Public Power District	Jamison Cawley		Affirmative	N/A
1	New York Power Authority	Salvatore Spagnolo		Affirmative	N/A
1	NextEra Energy - Florida Power and Light Co.	Mike O'Neil		Affirmative	N/A
1	NiSource - Northern Indiana Public Service Co.	Julaine Dyke		Affirmative	N/A
1	Northeast Missouri Electric Power Cooperative	Kevin White		Affirmative	N/A
1	NorthWestern Energy	Belinda Tierney		None	N/A
1	OGE Energy - Oklahoma Gas and Electric Co.	Terri Pyle		Affirmative	N/A
1	Oncor Electric Delivery	Rod Kinard	Gul Khan	Affirmative	N/A
1	OTP - Otter Tail Power Company	Charles Wicklund		Affirmative	N/A
1	Peak Reliability	Jared Shakespeare		Abstain	N/A
1	PHI - Potomac Electric Power Co.	David Thorne		Affirmative	N/A
1	Platte River Power Authority	John Collins		Affirmative	N/A
1	PNM Resources - Public Service Company of New Mexico	Laurie Williams		Affirmative	N/A
1	PPL Electric Utilities Corporation	Brenda Truhe		Abstain	N/A
1	PSEG - Public Service Electric and Gas Co.	Joseph Smith		Negative	Comments Submitted
1	Public Utility District	Long Duong		Affirmative	N/A

	No. 1 of Snohomish County				
1	Public Utility District No. 2 of Grant County, Washington	Michiko Sell		Affirmative	N/A
1	Sacramento Municipal Utility District	Tim Kelley	Joe Tarantino	Affirmative	N/A
1	Salt River Project	Steven Cobb		None	N/A
1	Santee Cooper	Shawn Abrams		Affirmative	N/A
1	SCANA - South Carolina Electric and Gas Co.	Tom Hanzlik		None	N/A
1	Seattle City Light	Pawel Krupa		Affirmative	N/A
1	Seminole Electric Cooperative, Inc.	Mark Churilla	Bret Galbraith	Affirmative	N/A
1	Sho-Me Power Electric Cooperative	Denise Stevens		Affirmative	N/A
1	Southern Company - Southern Company Services, Inc.	Robert A. Schaffeld		Affirmative	N/A
1	Southern Indiana Gas and Electric Co.	Steve Rawlinson		Affirmative	N/A
1	Southwest Transmission Cooperative, Inc.	John Shaver		Affirmative	N/A
1	Tacoma Public Utilities (Tacoma, WA)	John Merrell		Affirmative	N/A
1	Tallahassee Electric (City of Tallahassee, FL)	Scott Langston		Affirmative	N/A
1	Tennessee Valley Authority	Howell Scott		Abstain	N/A
1	Tri-State G and T Association, Inc.	Tracy Sliman		Affirmative	N/A
1	Unisource - Tucson Electric Power Co.	John Tolo		Affirmative	N/A

1	United Illuminating Co.	Jonathan Appelbaum		Affirmative	N/A
1	VELCO -Vermont Electric Power Company, Inc.	Kim Moulton		None	N/A
1	Westar Energy	Kevin Giles		Affirmative	N/A
1	Western Area Power Administration	Steve Johnson		None	N/A
1	Xcel Energy, Inc.	Dean Schiro		Affirmative	N/A
2	BC Hydro and Power Authority	Venkataramakrishnan Vinnakota		Abstain	N/A
2	Electric Reliability Council of Texas, Inc.	christina bigelow		Abstain	N/A
2	Herb Schrayshuen	Herb Schrayshuen		Affirmative	N/A
2	Independent Electricity System Operator	Leonard Kula		Affirmative	N/A
2	Midcontinent ISO, Inc.	Terry Blilke		None	N/A
2	New York Independent System Operator	Gregory Campoli		None	N/A
2	PJM Interconnection, L.L.C.	Mark Holman		Affirmative	N/A
2	Southwest Power Pool, Inc. (RTO)	Charles Yeung		Affirmative	N/A
3	Ameren - Ameren Services	David Jendras		Affirmative	N/A
3	Anaheim Public Utilities Dept.	Dennis Schmidt		Abstain	N/A
3	APS - Arizona Public Service Co.	Jeri Freimuth		Abstain	N/A
3	Associated Electric Cooperative, Inc.	Todd Bennett		Affirmative	N/A
3	Austin Energy	Lisa Martin		Affirmative	N/A

3	Avista - Avista Corporation	Scott Kinney		None	N/A
3	Basin Electric Power Cooperative	Jeremy Voll		Affirmative	N/A
3	BC Hydro and Power Authority	Pat Harrington		Abstain	N/A
3	Beaches Energy Services	Steven Lancaster		Affirmative	N/A
3	Berkshire Hathaway Energy - MidAmerican Energy Co.	Thomas Mielnik	Darnez Gresham	Affirmative	N/A
3	Bonneville Power Administration	Rebecca Berdahl		Affirmative	N/A
3	Central Electric Power Cooperative (Missouri)	Adam Weber		Affirmative	N/A
3	City of Green Cove Springs	Mark Schultz		Affirmative	N/A
3	City of Leesburg	Chris Adkins		Affirmative	N/A
3	City of Redding	Elizabeth Hadley	Bill Hughes	Affirmative	N/A
3	Clark Public Utilities	Jack Stamper		Affirmative	N/A
3	Cleco Corporation	Michelle Corley	Louis Guidry	Affirmative	N/A
3	CMS Energy - Consumers Energy Company	Karl Blaszkowski		Affirmative	N/A
3	Colorado Springs Utilities	Charles Morgan		None	N/A
3	Con Ed - Consolidated Edison Co. of New York	Peter Yost		Affirmative	N/A
3	Dominion - Dominion Resources, Inc.	Connie Lowe		Affirmative	N/A
3	DTE Energy - Detroit Edison Company	Kent Kujala		Affirmative	N/A
3	Duke Energy	Lee Schuster		Affirmative	N/A
3	East Kentucky Power	Patrick Woods		None	N/A

	Cooperative				
3	Edison International - Southern California Edison Company	Romel Aquino		Affirmative	N/A
3	Exelon	John Bee		Affirmative	N/A
3	FirstEnergy - FirstEnergy Corporation	Theresa Ciancio		Affirmative	N/A
3	Florida Municipal Power Agency	Joe McKinney		Affirmative	N/A
3	Georgia System Operations Corporation	Scott McGough		Affirmative	N/A
3	Grand River Dam Authority	Jeff Wells		Abstain	N/A
3	Great Plains Energy - Kansas City Power and Light Co.	Jessica Tucker	Douglas Webb	Affirmative	N/A
3	Great River Energy	Brian Glover		Affirmative	N/A
3	Hydro One Networks, Inc.	Paul Malozewski	Oshani Pathirane	Affirmative	N/A
3	JEA	Garry Baker		None	N/A
3	KAMO Electric Cooperative	Ted Hilmes		Affirmative	N/A
3	Lakeland Electric	Mace Hunter		Affirmative	N/A
3	Lincoln Electric System	Jason Fortik		Abstain	N/A
3	Los Angeles Department of Water and Power	Mike Anctil		Affirmative	N/A
3	M and A Electric Power Cooperative	Stephen Pogue		Affirmative	N/A
3	Manitoba Hydro	Karim Abdel-Hadi		Negative	Comments Submitted
3	MEAG Power	Roger Brand	Scott Miller	None	N/A
3	Modesto Irrigation	Jack Savage	Nick Braden	Affirmative	N/A

	District				
3	Muscatine Power and Water	Seth Shoemaker		Affirmative	N/A
3	National Grid USA	Brian Shanahan		Affirmative	N/A
3	Nebraska Public Power District	Tony Eddleman		Affirmative	N/A
3	New York Power Authority	David Rivera		Affirmative	N/A
3	NiSource - Northern Indiana Public Service Co.	Ramon Barany		None	N/A
3	North Carolina Electric Membership Corporation	doug white	Scott Brame	Affirmative	N/A
3	Northeast Missouri Electric Power Cooperative	Skyler Wiegmann		None	N/A
3	NW Electric Power Cooperative, Inc.	John Stickley		Affirmative	N/A
3	OGE Energy - Oklahoma Gas and Electric Co.	Donald Hargrove		Affirmative	N/A
3	PHI - Potomac Electric Power Co.	Mark Yerger		Affirmative	N/A
3	PNM Resources	Michael Mertz		Affirmative	N/A
3	PPL - Louisville Gas and Electric Co.	Charles Freibert		Abstain	N/A
3	PSEG - Public Service Electric and Gas Co.	Jeffrey Mueller		None	N/A
3	Public Utility District No. 1 of Okanogan County	Dale Dunckel		None	N/A
3	Puget Sound Energy, Inc.	Andrea Basinski		Abstain	N/A
3	Rutherford EMC	Tom Haire		Abstain	N/A
3	Sacramento	Rachel Moore	Joe Tarantino	Affirmative	N/A

	Municipal Utility District				
3	Salt River Project	John Coggins		Affirmative	N/A
3	Santee Cooper	James Poston		Affirmative	N/A
3	SCANA - South Carolina Electric and Gas Co.	Clay Young		Affirmative	N/A
3	Seattle City Light	Dana Wheelock		Affirmative	N/A
3	Seminole Electric Cooperative, Inc.	James Frauen		Affirmative	N/A
3	Sho-Me Power Electric Cooperative	Jeff Neas		None	N/A
3	Snohomish County PUD No. 1	Mark Oens		Affirmative	N/A
3	Southern Company - Alabama Power Company	R. Scott Moore		Affirmative	N/A
3	Southern Indiana Gas and Electric Co.	Jim Cox		Affirmative	N/A
3	Tacoma Public Utilities (Tacoma, WA)	Marc Donaldson		Affirmative	N/A
3	Tallahassee Electric (City of Tallahassee, FL)	John Williams		Affirmative	N/A
3	TECO - Tampa Electric Co.	Ronald Donahey		None	N/A
3	Tennessee Valley Authority	Ian Grant		Abstain	N/A
3	Tri-State G and T Association, Inc.	Janelle Marriott Gill		Affirmative	N/A
3	WEC Energy Group, Inc.	Jim Keller		Negative	Comments Submitted
3	Westar Energy	Bo Jones		Affirmative	N/A
3	Xcel Energy, Inc.	Michael Ibold		Affirmative	N/A
4	Alliant Energy	Kenneth Goldsmith		Affirmative	N/A

	Corporation Services, Inc.				
4	Austin Energy	Tina Garvey		Affirmative	N/A
4	Blue Ridge Power Agency	Duane Dahlquist		Affirmative	N/A
4	City of Clewiston	Lynne Mila		Affirmative	N/A
4	City of New Smyrna Beach Utilities Commission	Tim Beyrle		Affirmative	N/A
4	City of Redding	Nick Zettel	Bill Hughes	Affirmative	N/A
4	CMS Energy - Consumers Energy Company	Julie Hegedus		None	N/A
4	DTE Energy - Detroit Edison Company	Daniel Herring		Affirmative	N/A
4	FirstEnergy - Ohio Edison Company	Doug Hohlbaugh		Affirmative	N/A
4	Florida Municipal Power Agency	Carol Chinn		Affirmative	N/A
4	Georgia System Operations Corporation	Guy Andrews		None	N/A
4	Illinois Municipal Electric Agency	Bob Thomas		Affirmative	N/A
4	Keys Energy Services	Stanley Rzad		Affirmative	N/A
4	MGE Energy - Madison Gas and Electric Co.	Joseph DePoorter		Affirmative	N/A
4	Modesto Irrigation District	Spencer Tacke		None	N/A
4	North Carolina Electric Membership Corporation	John Lemire	Scott Brame	Affirmative	N/A
4	Oklahoma Municipal Power Authority	Ashley Stringer		Affirmative	N/A
4	Public Utility District	John Martinsen		Affirmative	N/A

	No. 1 of Snohomish County				
4	Public Utility District No. 2 of Grant County, Washington	Yvonne McMackin		Affirmative	N/A
4	Sacramento Municipal Utility District	Michael Ramirez	Joe Tarantino	Affirmative	N/A
4	Seattle City Light	Hao Li		Affirmative	N/A
4	Seminole Electric Cooperative, Inc.	Michael Ward		Affirmative	N/A
4	South Mississippi Electric Power Association	Steve McElhaney		None	N/A
4	Tacoma Public Utilities (Tacoma, WA)	Hien Ho		Affirmative	N/A
4	Utility Services, Inc.	Brian Evans-Mongeon		None	N/A
4	WEC Energy Group, Inc.	Anthony Jankowski		Negative	Comments Submitted
5	AEP	Thomas Foltz		Affirmative	N/A
5	Ameren - Ameren Missouri	Sam Dwyer		Affirmative	N/A
5	APS - Arizona Public Service Co.	Stephanie Little		Abstain	N/A
5	Associated Electric Cooperative, Inc.	Matthew Pacobit		Affirmative	N/A
5	Austin Energy	Jeanie Doty		Affirmative	N/A
5	Avista - Avista Corporation	Steve Wenke		None	N/A
5	Basin Electric Power Cooperative	Mike Kraft		Affirmative	N/A
5	BC Hydro and Power Authority	Clement Ma		Abstain	N/A
5	Berkshire Hathaway - NV Energy	Eric Schwarzrock		Affirmative	N/A
5	Boise-Kuna Irrigation	Mike Kukla		Affirmative	N/A

	District - Lucky Peak Power Plant Project				
5	Bonneville Power Administration	Francis Halpin		Affirmative	N/A
5	Brazos Electric Power Cooperative, Inc.	Shari Heino		Affirmative	N/A
5	Calpine Corporation	Hamid Zakery		Affirmative	N/A
5	Choctaw Generation Limited Partnership, LLLP	Rob Watson		Affirmative	N/A
5	City and County of San Francisco	Daniel Mason		Abstain	N/A
5	City of Independence, Power and Light Department	Jim Nail		Affirmative	N/A
5	City of Redding	Paul Cummings	Bill Hughes	Affirmative	N/A
5	Cleco Corporation	Stephanie Huffman	Louis Guidry	Affirmative	N/A
5	CMS Energy - Consumers Energy Company	David Greyerbiehl		Affirmative	N/A
5	Cogentrix Energy Power Management, LLC	Mike Hirst		Affirmative	N/A
5	Colorado Springs Utilities	Jeff Icke		None	N/A
5	Con Ed - Consolidated Edison Co. of New York	Brian O'Boyle		Affirmative	N/A
5	Dairyland Power Cooperative	Tommy Drea		Affirmative	N/A
5	Dominion - Dominion Resources, Inc.	Randi Heise		Affirmative	N/A
5	DTE Energy - Detroit Edison Company	Jeffrey DePriest		Affirmative	N/A
5	Duke Energy	Dale Goodwine		Affirmative	N/A

5	Dynegy Inc.	Dan Roethemeyer		Affirmative	N/A
5	East Kentucky Power Cooperative	Steve Ricker		Affirmative	N/A
5	Edison International - Southern California Edison Company	Michael McSpadden		None	N/A
5	Entergy - Entergy Services, Inc.	Tracey Stubbs		None	N/A
5	Essential Power, LLC	Gerry Adamski		Affirmative	N/A
5	Exelon	Vince Catania		Affirmative	N/A
5	FirstEnergy - FirstEnergy Solutions	Robert Loy		Affirmative	N/A
5	Florida Municipal Power Agency	David Schumann		Affirmative	N/A
5	Great Plains Energy - Kansas City Power and Light Co.	Harold Wyble	Douglas Webb	Affirmative	N/A
5	Great River Energy	Preston Walsh		Affirmative	N/A
5	Hydro-Qu?bec Production	Roger Dufresne		Affirmative	N/A
5	JEA	John Babik		Affirmative	N/A
5	Lakeland Electric	Jim Howard		None	N/A
5	Lincoln Electric System	Kayleigh Wilkerson		Abstain	N/A
5	Los Angeles Department of Water and Power	Kenneth Silver		None	N/A
5	Lower Colorado River Authority	Dixie Wells		Affirmative	N/A
5	Luminant - Luminant Generation Company LLC	Rick Terrill		Affirmative	N/A
5	Manitoba Hydro	Yuguang Xiao		Negative	Comments Submitted
5	Massachusetts Municipal Wholesale	David Gordon		Affirmative	N/A

	Electric Company				
5	MEAG Power	Steven Grego	Scott Miller	None	N/A
5	Muscatine Power and Water	Mike Avesing		Affirmative	N/A
5	NB Power Corporation	Rob Vance		Affirmative	N/A
5	Nebraska Public Power District	Don Schmit		Affirmative	N/A
5	New York Power Authority	Wayne Sipperly		Affirmative	N/A
5	NextEra Energy	Allen Schriver		Affirmative	N/A
5	NiSource - Northern Indiana Public Service Co.	Michael Melvin		Affirmative	N/A
5	North Carolina Electric Membership Corporation	Robert Beadle	Scott Brame	Affirmative	N/A
5	OGE Energy - Oklahoma Gas and Electric Co.	Leo Staples		Affirmative	N/A
5	Oglethorpe Power Corporation	Bernard Johnson		None	N/A
5	Omaha Public Power District	Mahmood Safi		Affirmative	N/A
5	OTP - Otter Tail Power Company	Cathy Fogale		Affirmative	N/A
5	Oxy - Ingleside Cogeneration LP	Michelle D'Antuono		Affirmative	N/A
5	Pacific Gas and Electric Company	Alex Chua		Abstain	N/A
5	Platte River Power Authority	Tyson Archie		Affirmative	N/A
5	Portland General Electric Co.	Matt Jastram		None	N/A
5	PPL Electric Utilities Corporation	Dan Wilson		Abstain	N/A
5	PSEG - PSEG Fossil	Tim Kucey		Negative	Comments

	LLC				Submitted
5	Public Utility District No. 1 of Snohomish County	Sam Nietfeld		Affirmative	N/A
5	Public Utility District No. 2 of Grant County, Washington	Alex Ybarra		Affirmative	N/A
5	Puget Sound Energy, Inc.	Lynda Kupfer		Abstain	N/A
5	Sacramento Municipal Utility District	Susan Gill-Zobitz	Joe Tarantino	Affirmative	N/A
5	Salt River Project	Kevin Nielsen		Affirmative	N/A
5	SCANA - South Carolina Electric and Gas Co.	Edward Magic		Affirmative	N/A
5	Seattle City Light	Mike Haynes		Affirmative	N/A
5	Southern Company - Southern Company Generation	William D. Shultz		Affirmative	N/A
5	Southern Indiana Gas and Electric Co.	Scotty Brown	Rob Collins	Affirmative	N/A
5	Tacoma Public Utilities (Tacoma, WA)	Chris Mattson		Affirmative	N/A
5	Talen Generation, LLC	Donald Lock		Affirmative	N/A
5	Tallahassee Electric (City of Tallahassee, FL)	Karen Webb		Affirmative	N/A
5	TECO - Tampa Electric Co.	R James Rocha		None	N/A
5	Tennessee Valley Authority	Brandy Spraker		Abstain	N/A
5	WEC Energy Group, Inc.	Linda Horn		Negative	Comments Submitted
5	Westar Energy	stephanie johnson		Affirmative	N/A

5	Xcel Energy, Inc.	Mark Castagneri		Affirmative	N/A
6	Ameren - Ameren Services	Robert Quinlivan		Affirmative	N/A
6	APS - Arizona Public Service Co.	Bobbi Welch		Abstain	N/A
6	Associated Electric Cooperative, Inc.	Brian Ackermann		Affirmative	N/A
6	Austin Energy	Andrew Gallo		Affirmative	N/A
6	Berkshire Hathaway - PacifiCorp	Sandra Shaffer		Affirmative	N/A
6	Bonneville Power Administration	Alex Spain		Affirmative	N/A
6	City of Redding	Marvin Briggs	Bill Hughes	Affirmative	N/A
6	Cleco Corporation	Robert Hirschak	Louis Guidry	Affirmative	N/A
6	Colorado Springs Utilities	Shannon Fair		None	N/A
6	Con Ed - Consolidated Edison Co. of New York	Robert Winston		Affirmative	N/A
6	Dominion - Dominion Resources, Inc.	Louis Slade		Affirmative	N/A
6	Duke Energy	Greg Cecil		Affirmative	N/A
6	Exelon	Dave Carlson		Affirmative	N/A
6	FirstEnergy - FirstEnergy Solutions	Ann Ivanc	Richard Hoag	Affirmative	N/A
6	Florida Municipal Power Agency	Richard Montgomery		Affirmative	N/A
6	Florida Municipal Power Pool	Tom Reedy		Affirmative	N/A
6	Great Plains Energy - Kansas City Power and Light Co.	Chris Bridges	Douglas Webb	Affirmative	N/A
6	Great River Energy	Donna Stephenson	Michael Brytowski	Affirmative	N/A
6	Lower Colorado River Authority	Michael Shaw		Affirmative	N/A

6	Manitoba Hydro	Blair Mukanik		Negative	Comments Submitted
6	Modesto Irrigation District	James McFall	Nick Braden	Affirmative	N/A
6	Muscatine Power and Water	Ryan Streck		Affirmative	N/A
6	New York Power Authority	Shivaz Chopra		Affirmative	N/A
6	NextEra Energy - Florida Power and Light Co.	Silvia Mitchell		Affirmative	N/A
6	NiSource - Northern Indiana Public Service Co.	Joe O'Brien		Affirmative	N/A
6	OGE Energy - Oklahoma Gas and Electric Co.	Jerry Nottnagel		None	N/A
6	Oglethorpe Power Corporation	Donna Johnson		None	N/A
6	Platte River Power Authority	Carol Ballantine		Affirmative	N/A
6	Portland General Electric Co.	Shawn Davis		Affirmative	N/A
6	PPL - Louisville Gas and Electric Co.	OELKER LINN		Abstain	N/A
6	Sacramento Municipal Utility District	Diane Clark	Joe Tarantino	Affirmative	N/A
6	Salt River Project	William Abraham	Chris Janick	Affirmative	N/A
6	Santee Cooper	Michael Brown		Affirmative	N/A
6	Seattle City Light	Charles Freeman		Affirmative	N/A
6	Seminole Electric Cooperative, Inc.	Trudy Novak		Affirmative	N/A
6	Snohomish County PUD No. 1	Kenn Backholm		Affirmative	N/A
6	Southern Company -	John J. Ciza		Affirmative	N/A

	Southern Company Generation and Energy Marketing				
6	Southern Indiana Gas and Electric Co.	Brad Lisembee		Affirmative	N/A
6	Tacoma Public Utilities (Tacoma, WA)	Rick Applegate		Affirmative	N/A
6	Talen Energy Marketing, LLC	Elizabeth Davis		Affirmative	N/A
6	TECO - Tampa Electric Co.	Benjamin Smith		None	N/A
6	Tennessee Valley Authority	Marjorie Parsons		Abstain	N/A
6	WEC Energy Group, Inc.	David Hathaway		Negative	Comments Submitted
6	Westar Energy	Tiffany Lake		Affirmative	N/A
6	Xcel Energy, Inc.	Peter Colussy		Affirmative	N/A
7	Exxon Mobil	Jay Barnett		Abstain	N/A
7	Luminant Mining Company LLC	Stewart Rake		Affirmative	N/A
8	David Kiguel	David Kiguel		Affirmative	N/A
8	Massachusetts Attorney General	Frederick Plett		Affirmative	N/A
9	City of Vero Beach	Ginny Beigel		Affirmative	N/A
9	Commonwealth of Massachusetts Department of Public Utilities	Donald Nelson		Affirmative	N/A
10	Florida Reliability Coordinating Council	Peter Heidrich		Affirmative	N/A
10	Midwest Reliability Organization	Russel Mountjoy		Affirmative	N/A
10	Northeast Power Coordinating Council	Guy V. Zito		Affirmative	N/A
10	ReliabilityFirst	Anthony Jablonski		Affirmative	N/A

10	SERC Reliability Corporation	Joe Spencer		Affirmative	N/A
10	Southwest Power Pool Regional Entity	Bob Reynolds		Affirmative	N/A
10	Texas Reliability Entity, Inc.	Rachel Coyne		Abstain	N/A
10	Western Electricity Coordinating Council	Steven Rueckert		Affirmative	N/A

Previous

1

Next

Showing 1 to 330 of 330 entries

NERC Balloting Tool (/)

[Dashboard \(/\)](#)
[Users](#)
[Ballots](#)
[Surveys](#)
[Legacy SBS \(https://standards.nerc.net/\)](#)
[Login \(/Users/Login\)](#) / [Register \(/Users/Register\)](#)

BALLOT RESULTS

Survey: [View Survey Results \(/SurveyResults/Index/24\)](#)

Ballot Name: 2007-17.4 PRC-005 FERC Order No. 803 Directive PRC-005-6 Non-binding Poll IN 1 NB

Voting Start Date: 9/4/2015 12:01:00 AM

Voting End Date: 9/16/2015 8:00:00 PM

Ballot Type: NB

Ballot Activity: IN

Ballot Series: 1

Total # Votes: 249

Total Ballot Pool: 294

Quorum: 84.69

Weighted Segment Value: 96.46

Segment	Ballot Pool	Segment Weight	Affirmative Votes	Affirmative Fraction	Negative Votes w/ Comment	Negative Fraction w/ Comment	Negative Votes w/o Comment	Abstain	No Vote
Segment: 1	74	1	48	0.96	2	0.04	0	14	10
Segment: 2	8	0.3	3	0.3	0	0	0	3	2
Segment: 3	71	1	44	0.957	2	0.043	0	13	12
Segment: 4	21	1	16	0.941	1	0.059	0	1	3
Segment: 5	68	1	43	0.977	1	0.023	0	11	13
Segment: 6	38	1	26	0.963	1	0.037	0	6	5
Segment: 7	2	0.1	1	0.1	0	0	0	1	0
Segment: 8	2	0.2	2	0.2	0	0	0	0	0
Segment: 2	2	0.2	2	0.2	0	0	0	0	0

9									
Segment: 10	8	0.6	6	0.6	0	0	0	2	0
Totals:	294	6.4	191	6.198	7	0.202	0	51	45

BALLOT POOL MEMBERS

Show entries

Search:

Segment	Organization	Voter	Designated Proxy	Ballot	NERC Memo
1	Ameren - Ameren Services	Eric Scott		Abstain	N/A
1	APS - Arizona Public Service Co.	Michelle Amarantos		Abstain	N/A
1	Associated Electric Cooperative, Inc.	Phil Hart		Affirmative	N/A
1	Avista - Avista Corporation	Bryan Cox	Rich Hydzik	Affirmative	N/A
1	Balancing Authority of Northern California	Kevin Smith	Joe Tarantino	Affirmative	N/A
1	BC Hydro and Power Authority	Patricia Robertson		Abstain	N/A
1	Beaches Energy Services	Don Cuevas		Affirmative	N/A
1	Berkshire Hathaway Energy - MidAmerican Energy Co.	Terry Harbour		Affirmative	N/A
1	Bonneville Power Administration	Donald Watkins		Affirmative	N/A
1	Brazos Electric	Tony Kroskey		None	N/A

	Power Cooperative, Inc.				
1	Bryan Texas Utilities	John Fontenot		Affirmative	N/A
1	CenterPoint Energy Houston Electric, LLC	John Brockhan		Abstain	N/A
1	Central Electric Power Cooperative (Missouri)	Michael Bax		None	N/A
1	Cleco Corporation	John Lindsey	Louis Guidry	Affirmative	N/A
1	Colorado Springs Utilities	Shawna Speer		None	N/A
1	Con Ed - Consolidated Edison Co. of New York	Chris de Graffenried		Affirmative	N/A
1	Dairyland Power Cooperative	Robert Roddy		Abstain	N/A
1	Dominion - Dominion Virginia Power	Larry Nash		Abstain	N/A
1	Duke Energy	Doug Hils		Affirmative	N/A
1	East Kentucky Power Cooperative	Amber Skillern		Affirmative	N/A
1	Edison International - Southern California Edison Company	Steven Mavis		Affirmative	N/A
1	Entergy - Entergy Services, Inc.	Oliver Burke		Affirmative	N/A
1	FirstEnergy - FirstEnergy Corporation	William Smith		Affirmative	N/A
1	Georgia Transmission Corporation	Jason Snodgrass		Affirmative	N/A
1	Great Plains Energy - Kansas City Power and Light Co.	James McBee	Douglas Webb	Affirmative	N/A
1	Great River Energy	Gordon Pietsch		Affirmative	N/A

1	Hoosier Energy Rural Electric Cooperative, Inc.	Bob Solomon		None	N/A
1	Hydro One Networks, Inc.	Payam Farahbakhsh	Oshani Pathirane	Negative	Comments Submitted
1	Hydro-Quebec TransEnergie	Martin Boisvert		Affirmative	N/A
1	IDACORP - Idaho Power Company	Molly Devine		Affirmative	N/A
1	International Transmission Company Holdings Corporation	Michael Moltane	Meghan Ferguson	Abstain	N/A
1	KAMO Electric Cooperative	Walter Kenyon		Affirmative	N/A
1	Los Angeles Department of Water and Power	faranak sarbaz		Abstain	N/A
1	Lower Colorado River Authority	Teresa Cantwell		Affirmative	N/A
1	M and A Electric Power Cooperative	William Price		Affirmative	N/A
1	Manitoba Hydro	Mike Smith		Negative	Comments Submitted
1	MEAG Power	David Weekley	Scott Miller	None	N/A
1	Muscatine Power and Water	Andy Kurriger		Affirmative	N/A
1	N.W. Electric Power Cooperative, Inc.	Mark Ramsey		Affirmative	N/A
1	National Grid USA	Michael Jones		Affirmative	N/A
1	Nebraska Public Power District	Jamison Cawley		Abstain	N/A
1	New York Power Authority	Salvatore Spagnolo		Affirmative	N/A
1	NextEra Energy - Florida Power and Light Co.	Mike O'Neil		Affirmative	N/A

1	NiSource - Northern Indiana Public Service Co.	Julaine Dyke		Affirmative	N/A
1	Northeast Missouri Electric Power Cooperative	Kevin White		Affirmative	N/A
1	NorthWestern Energy	Belinda Tierney		None	N/A
1	OGE Energy - Oklahoma Gas and Electric Co.	Terri Pyle		Affirmative	N/A
1	Oncor Electric Delivery	Rod Kinard	Gul Khan	Affirmative	N/A
1	Peak Reliability	Jared Shakespeare		Abstain	N/A
1	Platte River Power Authority	John Collins		Abstain	N/A
1	PNM Resources - Public Service Company of New Mexico	Laurie Williams		Affirmative	N/A
1	PPL Electric Utilities Corporation	Brenda Truhe		Abstain	N/A
1	PSEG - Public Service Electric and Gas Co.	Joseph Smith		Abstain	N/A
1	Public Utility District No. 1 of Snohomish County	Long Duong		Affirmative	N/A
1	Public Utility District No. 2 of Grant County, Washington	Michiko Sell		Affirmative	N/A
1	Sacramento Municipal Utility District	Tim Kelley	Joe Tarantino	Affirmative	N/A
1	Salt River Project	Steven Cobb		None	N/A
1	Santee Cooper	Shawn Abrams		Affirmative	N/A
1	SCANA - South Carolina Electric and	Tom Hanzlik		None	N/A

	Gas Co.				
1	Seattle City Light	Pawel Krupa		Affirmative	N/A
1	Seminole Electric Cooperative, Inc.	Mark Churilla	Bret Galbraith	Affirmative	N/A
1	Sho-Me Power Electric Cooperative	Denise Stevens		Affirmative	N/A
1	Southern Company - Southern Company Services, Inc.	Robert A. Schaffeld		Affirmative	N/A
1	Southern Indiana Gas and Electric Co.	Steve Rawlinson		Affirmative	N/A
1	Southwest Transmission Cooperative, Inc.	John Shaver		Affirmative	N/A
1	Tacoma Public Utilities (Tacoma, WA)	John Merrell		Affirmative	N/A
1	Tallahassee Electric (City of Tallahassee, FL)	Scott Langston		Affirmative	N/A
1	Tennessee Valley Authority	Howell Scott		Abstain	N/A
1	Tri-State G and T Association, Inc.	Tracy Sliman		Affirmative	N/A
1	Unisource - Tucson Electric Power Co.	John Tolo		Affirmative	N/A
1	United Illuminating Co.	Jonathan Appelbaum		Affirmative	N/A
1	VELCO -Vermont Electric Power Company, Inc.	Kim Moulton		None	N/A
1	Westar Energy	Kevin Giles		Affirmative	N/A
1	Western Area Power Administration	Steve Johnson		None	N/A
2	BC Hydro and Power Authority	Venkataramakrishnan Vinnakota		Abstain	N/A
2	Electric Reliability	christina bigelow		Abstain	N/A

	Council of Texas, Inc.				
2	Herb Schrayshuen	Herb Schrayshuen		Affirmative	N/A
2	Independent Electricity System Operator	Leonard Kula		Affirmative	N/A
2	Midcontinent ISO, Inc.	Terry Blilke		None	N/A
2	New York Independent System Operator	Gregory Campoli		None	N/A
2	PJM Interconnection, L.L.C.	Mark Holman		Affirmative	N/A
2	Southwest Power Pool, Inc. (RTO)	Charles Yeung		Abstain	N/A
3	Ameren - Ameren Services	David Jendras		Abstain	N/A
3	Anaheim Public Utilities Dept.	Dennis Schmidt		Abstain	N/A
3	APS - Arizona Public Service Co.	Jeri Freimuth		Abstain	N/A
3	Associated Electric Cooperative, Inc.	Todd Bennett		Affirmative	N/A
3	Austin Energy	Lisa Martin		Affirmative	N/A
3	Avista - Avista Corporation	Scott Kinney		None	N/A
3	Basin Electric Power Cooperative	Jeremy Voll		Affirmative	N/A
3	BC Hydro and Power Authority	Pat Harrington		Abstain	N/A
3	Beaches Energy Services	Steven Lancaster		Affirmative	N/A
3	Berkshire Hathaway Energy - MidAmerican Energy Co.	Thomas Mielnik	Darnez Gresham	Affirmative	N/A
3	Bonneville Power	Rebecca Berdahl		Affirmative	N/A

	Administration				
3	Central Electric Power Cooperative (Missouri)	Adam Weber		Affirmative	N/A
3	City of Green Cove Springs	Mark Schultz		Affirmative	N/A
3	City of Leesburg	Chris Adkins		Affirmative	N/A
3	Clark Public Utilities	Jack Stamper		Affirmative	N/A
3	Cleco Corporation	Michelle Corley	Louis Guidry	Affirmative	N/A
3	CMS Energy - Consumers Energy Company	Karl Blaszkowski		Affirmative	N/A
3	Colorado Springs Utilities	Charles Morgan		None	N/A
3	Con Ed - Consolidated Edison Co. of New York	Peter Yost		Affirmative	N/A
3	Dominion - Dominion Resources, Inc.	Connie Lowe		Abstain	N/A
3	DTE Energy - Detroit Edison Company	Kent Kujala		Affirmative	N/A
3	Duke Energy	Lee Schuster		Affirmative	N/A
3	East Kentucky Power Cooperative	Patrick Woods		None	N/A
3	Edison International - Southern California Edison Company	Romel Aquino		Affirmative	N/A
3	FirstEnergy - FirstEnergy Corporation	Theresa Ciancio		Affirmative	N/A
3	Florida Municipal Power Agency	Joe McKinney		Affirmative	N/A
3	Georgia System Operations Corporation	Scott McGough		Affirmative	N/A
3	Grand River Dam Authority	Jeff Wells		Abstain	N/A

3	Great Plains Energy - Kansas City Power and Light Co.	Jessica Tucker	Douglas Webb	Affirmative	N/A
3	Great River Energy	Brian Glover		Affirmative	N/A
3	Hydro One Networks, Inc.	Paul Malozewski	Oshani Pathirane	Negative	Comments Submitted
3	JEA	Garry Baker		None	N/A
3	KAMO Electric Cooperative	Ted Hilmes		Affirmative	N/A
3	Lakeland Electric	Mace Hunter		Affirmative	N/A
3	Lincoln Electric System	Jason Fortik		Abstain	N/A
3	Los Angeles Department of Water and Power	Mike Anctil		Affirmative	N/A
3	M and A Electric Power Cooperative	Stephen Pogue		Affirmative	N/A
3	Manitoba Hydro	Karim Abdel-Hadi		Negative	Comments Submitted
3	MEAG Power	Roger Brand	Scott Miller	None	N/A
3	Modesto Irrigation District	Jack Savage	Nick Braden	Affirmative	N/A
3	Muscatine Power and Water	Seth Shoemaker		Affirmative	N/A
3	National Grid USA	Brian Shanahan		Affirmative	N/A
3	Nebraska Public Power District	Tony Eddleman		Abstain	N/A
3	New York Power Authority	David Rivera		Affirmative	N/A
3	NiSource - Northern Indiana Public Service Co.	Ramon Barany		None	N/A
3	North Carolina Electric Membership Corporation	doug white	Scott Brame	Affirmative	N/A
3	Northeast Missouri	Skyler Wiegmann		None	N/A

	Electric Power Cooperative				
3	NW Electric Power Cooperative, Inc.	John Stickley		Affirmative	N/A
3	OGE Energy - Oklahoma Gas and Electric Co.	Donald Hargrove		Affirmative	N/A
3	PNM Resources	Michael Mertz		Affirmative	N/A
3	PPL - Louisville Gas and Electric Co.	Charles Freibert		None	N/A
3	PSEG - Public Service Electric and Gas Co.	Jeffrey Mueller		None	N/A
3	Public Utility District No. 1 of Okanogan County	Dale Dunckel		None	N/A
3	Puget Sound Energy, Inc.	Andrea Basinski		Abstain	N/A
3	Rutherford EMC	Tom Haire		Abstain	N/A
3	Sacramento Municipal Utility District	Rachel Moore	Joe Tarantino	Affirmative	N/A
3	Salt River Project	John Coggins		Affirmative	N/A
3	Santee Cooper	James Poston		Affirmative	N/A
3	SCANA - South Carolina Electric and Gas Co.	Clay Young		Affirmative	N/A
3	Seattle City Light	Dana Wheelock		Affirmative	N/A
3	Seminole Electric Cooperative, Inc.	James Frauen		Affirmative	N/A
3	Sho-Me Power Electric Cooperative	Jeff Neas		None	N/A
3	Snohomish County PUD No. 1	Mark Oens		Affirmative	N/A
3	Southern Company - Alabama Power Company	R. Scott Moore		Affirmative	N/A

3	Tacoma Public Utilities (Tacoma, WA)	Marc Donaldson		Affirmative	N/A
3	Tallahassee Electric (City of Tallahassee, FL)	John Williams		Abstain	N/A
3	TECO - Tampa Electric Co.	Ronald Donahey		None	N/A
3	Tennessee Valley Authority	Ian Grant		Abstain	N/A
3	Tri-State G and T Association, Inc.	Janelle Marriott Gill		Affirmative	N/A
3	Westar Energy	Bo Jones		Affirmative	N/A
3	Xcel Energy, Inc.	Michael Ibold		Abstain	N/A
4	Alliant Energy Corporation Services, Inc.	Kenneth Goldsmith		Affirmative	N/A
4	Austin Energy	Tina Garvey		Affirmative	N/A
4	Blue Ridge Power Agency	Duane Dahlquist		Affirmative	N/A
4	City of Clewiston	Lynne Mila		Affirmative	N/A
4	City of New Smyrna Beach Utilities Commission	Tim Beyrle		Affirmative	N/A
4	DTE Energy - Detroit Edison Company	Daniel Herring		Affirmative	N/A
4	FirstEnergy - Ohio Edison Company	Doug Hohlbaugh		Affirmative	N/A
4	Florida Municipal Power Agency	Carol Chinn		Affirmative	N/A
4	Georgia System Operations Corporation	Guy Andrews		None	N/A
4	Illinois Municipal Electric Agency	Bob Thomas		Abstain	N/A
4	Keys Energy Services	Stanley Rząd		Affirmative	N/A

4	North Carolina Electric Membership Corporation	John Lemire	Scott Brame	Affirmative	N/A
4	Public Utility District No. 1 of Snohomish County	John Martinsen		Affirmative	N/A
4	Public Utility District No. 2 of Grant County, Washington	Yvonne McMackin		Affirmative	N/A
4	Sacramento Municipal Utility District	Michael Ramirez	Joe Tarantino	Affirmative	N/A
4	Seattle City Light	Hao Li		Affirmative	N/A
4	Seminole Electric Cooperative, Inc.	Michael Ward		Affirmative	N/A
4	South Mississippi Electric Power Association	Steve McElhaney		None	N/A
4	Tacoma Public Utilities (Tacoma, WA)	Hien Ho		Affirmative	N/A
4	Utility Services, Inc.	Brian Evans-Mongeon		None	N/A
4	WEC Energy Group, Inc.	Anthony Jankowski		Negative	Comments Submitted
5	AEP	Thomas Foltz		Abstain	N/A
5	Ameren - Ameren Missouri	Sam Dwyer		Abstain	N/A
5	APS - Arizona Public Service Co.	Stephanie Little		Abstain	N/A
5	Associated Electric Cooperative, Inc.	Matthew Pacobit		Affirmative	N/A
5	Austin Energy	Jeanie Doty		Affirmative	N/A
5	Basin Electric Power Cooperative	Mike Kraft		Affirmative	N/A
5	BC Hydro and Power Authority	Clement Ma		Abstain	N/A
5	Berkshire Hathaway -	Eric Schwarzrock		None	N/A

	NV Energy				
5	Boise-Kuna Irrigation District - Lucky Peak Power Plant Project	Mike Kukla		Affirmative	N/A
5	Bonneville Power Administration	Francis Halpin		Affirmative	N/A
5	Brazos Electric Power Cooperative, Inc.	Shari Heino		Affirmative	N/A
5	Calpine Corporation	Hamid Zakery		Affirmative	N/A
5	Choctaw Generation Limited Partnership, LLLP	Rob Watson		Affirmative	N/A
5	City of Independence, Power and Light Department	Jim Nail		Affirmative	N/A
5	Cleco Corporation	Stephanie Huffman	Louis Guidry	Affirmative	N/A
5	CMS Energy - Consumers Energy Company	David Greyerbiehl		Affirmative	N/A
5	Cogentrix Energy Power Management, LLC	Mike Hirst		Affirmative	N/A
5	Colorado Springs Utilities	Jeff Icke		None	N/A
5	Con Ed - Consolidated Edison Co. of New York	Brian O'Boyle		Affirmative	N/A
5	Dairyland Power Cooperative	Tommy Drea		Affirmative	N/A
5	DTE Energy - Detroit Edison Company	Jeffrey DePriest		Affirmative	N/A
5	Duke Energy	Dale Goodwine		Affirmative	N/A
5	Dynegy Inc.	Dan Roethemeyer		Affirmative	N/A
5	East Kentucky Power Cooperative	Steve Ricker		Affirmative	N/A

5	Edison International - Southern California Edison Company	Michael McSpadden		None	N/A
5	Entergy - Entergy Services, Inc.	Tracey Stubbs		None	N/A
5	FirstEnergy - FirstEnergy Solutions	Robert Loy		Affirmative	N/A
5	Florida Municipal Power Agency	David Schumann		Affirmative	N/A
5	Great Plains Energy - Kansas City Power and Light Co.	Harold Wyble	Douglas Webb	Affirmative	N/A
5	Great River Energy	Preston Walsh		Affirmative	N/A
5	Hydro-Quebec Production	Roger Dufresne		Affirmative	N/A
5	JEA	John Babik		Affirmative	N/A
5	Lakeland Electric	Jim Howard		None	N/A
5	Lincoln Electric System	Kayleigh Wilkerson		Abstain	N/A
5	Los Angeles Department of Water and Power	Kenneth Silver		None	N/A
5	Lower Colorado River Authority	Dixie Wells		Affirmative	N/A
5	Luminant - Luminant Generation Company LLC	Rick Terrill		Affirmative	N/A
5	Manitoba Hydro	Yuguang Xiao		Negative	Comments Submitted
5	Massachusetts Municipal Wholesale Electric Company	David Gordon		Abstain	N/A
5	MEAG Power	Steven Grego	Scott Miller	None	N/A
5	Muscatine Power and Water	Mike Avesing		Affirmative	N/A
5	Nebraska Public Power District	Don Schmit		Abstain	N/A

5	New York Power Authority	Wayne Sipperly		Affirmative	N/A
5	NextEra Energy	Allen Schriver		Affirmative	N/A
5	NiSource - Northern Indiana Public Service Co.	Michael Melvin		Affirmative	N/A
5	OGE Energy - Oklahoma Gas and Electric Co.	Leo Staples		Affirmative	N/A
5	Oglethorpe Power Corporation	Bernard Johnson		None	N/A
5	Omaha Public Power District	Mahmood Safi		Affirmative	N/A
5	Oxy - Ingleside Cogeneration LP	Michelle D'Antuono		Affirmative	N/A
5	Pacific Gas and Electric Company	Alex Chua		Abstain	N/A
5	Portland General Electric Co.	Matt Jastram		None	N/A
5	PPL Electric Utilities Corporation	Dan Wilson		None	N/A
5	PSEG - PSEG Fossil LLC	Tim Kucey		Abstain	N/A
5	Public Utility District No. 1 of Snohomish County	Sam Nietfeld		Affirmative	N/A
5	Public Utility District No. 2 of Grant County, Washington	Alex Ybarra		Affirmative	N/A
5	Puget Sound Energy, Inc.	Lynda Kupfer		Abstain	N/A
5	Sacramento Municipal Utility District	Susan Gill-Zobitz	Joe Tarantino	Affirmative	N/A
5	Salt River Project	Kevin Nielsen		Affirmative	N/A
5	SCANA - South Carolina Electric and Gas Co.	Edward Magic		Affirmative	N/A

5	Seattle City Light	Mike Haynes		Affirmative	N/A
5	Southern Company - Southern Company Generation	William D. Shultz		Affirmative	N/A
5	Southern Indiana Gas and Electric Co.	Scotty Brown	Rob Collins	None	N/A
5	Tacoma Public Utilities (Tacoma, WA)	Chris Mattson		Affirmative	N/A
5	Tallahassee Electric (City of Tallahassee, FL)	Karen Webb		Affirmative	N/A
5	TECO - Tampa Electric Co.	R James Rocha		None	N/A
5	Tennessee Valley Authority	Brandy Spraker		Abstain	N/A
5	Westar Energy	stephanie johnson		Affirmative	N/A
5	Xcel Energy, Inc.	David Lemmons		None	N/A
6	Ameren - Ameren Services	Robert Quinlivan		Abstain	N/A
6	APS - Arizona Public Service Co.	Bobbi Welch		Abstain	N/A
6	Associated Electric Cooperative, Inc.	Brian Ackermann		Affirmative	N/A
6	Austin Energy	Andrew Gallo		Affirmative	N/A
6	Berkshire Hathaway - PacifiCorp	Sandra Shaffer		Abstain	N/A
6	Bonneville Power Administration	Alex Spain		Affirmative	N/A
6	Cleco Corporation	Robert Hirschak	Louis Guidry	Affirmative	N/A
6	Colorado Springs Utilities	Shannon Fair		None	N/A
6	Con Ed - Consolidated Edison Co. of New York	Robert Winston		Affirmative	N/A
6	Duke Energy	Greg Cecil		Affirmative	N/A

6	FirstEnergy - FirstEnergy Solutions	Ann Ivanc	Richard Hoag	Affirmative	N/A
6	Florida Municipal Power Agency	Richard Montgomery		Affirmative	N/A
6	Florida Municipal Power Pool	Tom Reedy		Affirmative	N/A
6	Great Plains Energy - Kansas City Power and Light Co.	Chris Bridges	Douglas Webb	Affirmative	N/A
6	Great River Energy	Donna Stephenson	Michael Brytowski	Affirmative	N/A
6	Lower Colorado River Authority	Michael Shaw		Affirmative	N/A
6	Manitoba Hydro	Blair Mukanik		Negative	Comments Submitted
6	Muscatine Power and Water	Ryan Streck		Affirmative	N/A
6	New York Power Authority	Shivaz Chopra		Affirmative	N/A
6	NextEra Energy - Florida Power and Light Co.	Silvia Mitchell		Abstain	N/A
6	NiSource - Northern Indiana Public Service Co.	Joe O'Brien		Affirmative	N/A
6	OGE Energy - Oklahoma Gas and Electric Co.	Jerry Nottnagel		None	N/A
6	Oglethorpe Power Corporation	Donna Johnson		None	N/A
6	Platte River Power Authority	Carol Ballantine		Abstain	N/A
6	Portland General Electric Co.	Shawn Davis		Affirmative	N/A
6	PPL - Louisville Gas and Electric Co.	OELKER LINN		None	N/A
6	Sacramento	Diane Clark	Joe Tarantino	Affirmative	N/A

	Municipal Utility District				
6	Salt River Project	William Abraham	Chris Janick	Affirmative	N/A
6	Santee Cooper	Michael Brown		Affirmative	N/A
6	Seattle City Light	Charles Freeman		Affirmative	N/A
6	Seminole Electric Cooperative, Inc.	Trudy Novak		Affirmative	N/A
6	Snohomish County PUD No. 1	Kenn Backholm		Affirmative	N/A
6	Southern Company - Southern Company Generation and Energy Marketing	John J. Ciza		Affirmative	N/A
6	Tacoma Public Utilities (Tacoma, WA)	Rick Applegate		Affirmative	N/A
6	Talen Energy Marketing, LLC	Elizabeth Davis		Affirmative	N/A
6	TECO - Tampa Electric Co.	Benjamin Smith		None	N/A
6	Tennessee Valley Authority	Marjorie Parsons		Abstain	N/A
6	Westar Energy	Tiffany Lake		Affirmative	N/A
7	Exxon Mobil	Jay Barnett		Abstain	N/A
7	Luminant Mining Company LLC	Stewart Rake		Affirmative	N/A
8	David Kiguel	David Kiguel		Affirmative	N/A
8	Massachusetts Attorney General	Frederick Plett		Affirmative	N/A
9	City of Vero Beach	Ginny Beigel		Affirmative	N/A
9	Commonwealth of Massachusetts Department of Public Utilities	Donald Nelson		Affirmative	N/A
10	Florida Reliability Coordinating Council	Peter Heidrich		Affirmative	N/A

10	Midwest Reliability Organization	Russel Mountjoy		Affirmative	N/A
10	Northeast Power Coordinating Council	Guy V. Zito		Affirmative	N/A
10	ReliabilityFirst	Anthony Jablonski		Affirmative	N/A
10	SERC Reliability Corporation	Joe Spencer		Affirmative	N/A
10	Southwest Power Pool Regional Entity	Bob Reynolds		Affirmative	N/A
10	Texas Reliability Entity, Inc.	Rachel Coyne		Abstain	N/A
10	Western Electricity Coordinating Council	Steven Rueckert		Abstain	N/A

Previous

1

Next

Showing 1 to 294 of 294 entries

Survey Report

Survey Details

Name 2007-17.4 PRC-005 FERC Order No. 803 Directive | PRC-005-6

Description

Start Date 7/30/2015

End Date 9/16/2015

Associated Ballots

2007-17.4 PRC-005 FERC Order No. 803 Directive PRC-005-6 IN 1 ST

2007-17.4 PRC-005 FERC Order No. 803 Directive PRC-005-6 Non-binding Poll IN 1 NB

Survey Questions

1. The PSMTSDT has proposed revising the definition of “Automatic Reclosing” and “Component Type” to address the FERC directive in Order 803. Do you agree that the proposed revised definitions? If not, please provide specific comments regarding the revision and any suggestions for alternatives to address the directive.

Yes

No

2. The PSMTSDT has added Table 4-3 to address maintenance activities and intervals for voltage sensing devices associated with supervisory relays. Do you agree with the proposed table? If not, please provide specific comments regarding the table and any suggestions for alternative language.

Yes

No

3. The PSMTSDT has made revisions to the Supplementary Reference and FAQ Document. Do you agree with the proposed revisions? If not, please provide specific comments regarding the revisions and any suggestions for alternative language.

Yes

No

4. The PSMTSDT has proposed combining the Implementation Plans for previous versions of PRC-005 (including PRC-005-3, PRC-005-3i, PRC-005-3ii, PRC-005-4 and PRC-005-5). Do you agree with the proposed Implementation Plan? If not, please provide specific comments regarding the Implementation Plan and any suggestions for alternative language.

Yes

No

Responses By Question

1. The PSMTSDT has proposed revising the definition of “Automatic Reclosing” and “Component Type” to address the FERC directive in Order 803. Do you agree that the proposed revised definitions? If not, please provide specific comments regarding the revision and any suggestions for alternatives to address the directive.

John Fontenot - Bryan Texas Utilities - 1 -

Selected Answer: Yes

Answer Comment:

Document Name:

Likes: 0

Dislikes: 0

**Meghan Ferguson - International Transmission Company Holdings Corporation On Behalf of:
Michael Moltane, International Transmission Company Holdings Corporation, 1**

Selected Answer: Yes

Answer Comment:

Document Name:

Likes: 0

Dislikes: 0

Barbara Kedrowski - WEC Energy Group, Inc. - 3,4,5 - RFC

Selected Answer: No

Answer Comment:

The SDT needs to add to the definition of automatic reclosing to differentiate it from manual reclosing. This could be a possible area of confusion with compliance auditors.

Document Name:

Likes: 0

Dislikes: 0

Andrew Puztai - American Transmission Company, LLC - 1 -

Selected Answer: Yes

Answer Comment:

Document Name:

Likes: 0

Dislikes: 0

Thomas Foltz - AEP - 5 -

Selected Answer: Yes

Answer Comment:

Document Name:

Likes: 0

Dislikes: 0

Jamison Dye - Bonneville Power Administration - 1,3,5,6 - WECC

Selected Answer: Yes

Answer Comment:

Document Name:

Likes: 0

Dislikes: 0

Leonard Kula - Independent Electricity System Operator - 2 -

Selected Answer: Yes

Answer Comment:

Document Name:

Likes: 0

Dislikes: 0

Emily Rousseau - MRO - 1,2,3,4,5,6 - MRO

Group Information

Group Name: MRO-NERC Standards Review Forum (NSRF)

Group Member Name	Entity	Region	Segments
Joe Depoorter	Madison Gas & Electric	MRO	3,4,5,6
Amy Casucelli	Xcel Energy	MRO	1,3,5,6
Chuck Lawrence	American Transmission Company	MRO	1
Chuck Wicklund	Otter Tail Power Company	MRO	1,3,5
Theresa Allard	Minnkota Power Cooperative, Inc	MRO	1,3,5,6
Dave Rudolph	Basin Electric Power Cooperative	MRO	1,3,5,6
Kayleigh Wilkerson	Lincoln Electric System	MRO	1,3,5,6
Jodi Jenson	Western Area Power Administration	MRO	1,6
Larry Heckert	Alliant Energy	MRO	4
Mahmood Safi	Omaha Public Utility District	MRO	1,3,5,6
Shannon Weaver	Midwest ISO Inc.	MRO	2
Mike Brytowski	Great River Energy	MRO	1,3,5,6
Brad Perrett	Minnesota Power	MRO	1,5
Scott Nickels	Rochester Public Utilities	MRO	4
Terry Harbour	MidAmerican Energy Company	MRO	1,3,5,6
Tom Breene	Wisconsin Public Service Corporation	MRO	3,4,5,6
Tony Eddleman	Nebraska Public Power District	MRO	1,3,5

Voter Information

Voter	Segment
Emily Rousseau	1,2,3,4,5,6
Entity	Region(s)
MRO	MRO

Selected Answer: Yes

Answer Comment:

Document Name:

Likes: 0

Dislikes: 0

Gul Khan - Gul Khan On Behalf of: Rod Kinard, Oncor Electric Delivery, 1

Selected Answer: Yes

Answer Comment:

Document Name:

Likes: 0

Dislikes: 0

Amy Casuscelli - Xcel Energy, Inc. - 1,3,5,6 - MRO,WECC,SPP

Selected Answer: Yes

Answer Comment:

Document Name:

Likes: 0

Dislikes: 0

Adam Padgett - TECO - Tampa Electric Co. - 1,3,4,5 - FRCC

Selected Answer: Yes

Answer Comment:

Document Name:

Likes: 0

Dislikes: 0

Pamela Hunter - Southern Company - Southern Company Services, Inc. - 1,3,5,6 - SERC

Group Information

Group Name: Southern Company

Group Member Name	Entity	Region	Segments
Robert A. Schaffeld	Southern Company Services, Inc.	SERC	1
R. Scott Moore	Alabama Power Company	SERC	3
William D. Shultz	Southern Company Generation	SERC	5
John J. Ciza	Southern Company Generation and Energy Marketing	SERC	6

Voter Information

Voter **Segment**

Pamela Hunter 1,3,5,6

Entity **Region(s)**

Southern Company - Southern Company Services, Inc. SERC

Selected Answer:

Answer Comment:

Document Name:

Likes: 0

Dislikes: 0

John Fontenot - Bryan Texas Utilities - 1 -

Selected Answer: Yes

Answer Comment:

Document Name:

Likes: 0

Dislikes: 0

John Fontenot - Bryan Texas Utilities - 1 -

Selected Answer: Yes

Answer Comment:

Document Name:

Likes: 0

Dislikes: 0

John Coggins - Salt River Project - 3 -

Selected Answer: Yes

Answer Comment:

Document Name:

Likes: 0

Dislikes: 0

Molly Devine - IDACORP - Idaho Power Company - 1 -

Selected Answer: Yes

Answer Comment:

Document Name:

Likes: 0

Dislikes: 0

Rachel Coyne - Texas Reliability Entity, Inc. - 10 -

Selected Answer: Yes

Answer Comment:

The definition of Automatic Reclosing is not definitive on the functional aspect (Sudden Pressure Relaying provides functional aspect) and just delineates what Components are included. Is that the standard drafting team's intent? Does the use of the term "Automatic Reclosing" in Table 4-1 Maintenance Activities make sense without a functional aspect being defined?

Document Name:

Likes: 0

Dislikes: 0

John Seelke - PSEG - 1,3,5,6 - NPCC,RFC

Group Information

Group Name: PSEG

Group Member Name	Entity	Region	Segments
Joseph Smith	Public Service Electric and Gas	RFC	1
Jeffrey Mueller	Public Service Electric and Gas Co.	RFC	3
Tim Kucey	PSEG Fossil LLC	RFC	5
Karla Jara	PSEG Energy Resources & Trade LLC	RFC	6

Voter Information

Voter	Segment
John Seelke	1,3,5,6
Entity	Region(s)
PSEG	NPCC,RFC

Selected Answer: No

Answer Comment: We do not believe this standard is needed.

Document Name:

Likes: 2 PSEG - Public Service Electric and Gas Co., 1, Smith Joseph
PSEG - PSEG Fossil LLC, 5, Kucey Tim

Dislikes: 0

Mike Smith - Manitoba Hydro - 1 -

Selected Answer: Yes

Answer Comment:

Document Name:

Likes: 0

Dislikes: 0

David Jendras - Ameren - Ameren Services - 3 -

Selected Answer: Yes

Answer Comment:

Document Name:

Likes: 0

Dislikes: 0

Colby Bellville - Duke Energy - 1,3,5,6 - FRCC,SERC,RFC

Group Information

Group Name: Duke Energy

Group Member Name	Entity	Region	Segments
Doug Hils	Duke Energy	RFC	1
Lee Schuster	Duke Energy	FRCC	3
Dale Goodwine	Duke Energy	SERC	5
Greg Cecil	Duke Energy	RFC	6

Voter Information

Voter	Segment
Colby Bellville	1,3,5,6
Entity	Region(s)
Duke Energy	FRCC,SERC,RFC

Selected Answer: No

Answer Comment:

Duke Energy requests further clarification from the drafting team on the proposed definition of Automatic Reclosing. Is it the drafting team's intent that the definition should incorporate all closings that happen automatically, or just Automatic Reclosing relays? There are some scenarios where there is an automatic closing, but no relay is present. There are also some instances where a Supervisory relay is not supervising a reclosing relay, and just providing a close command itself. Would these Supervisory relays that do not supervise an Automatic Reclosing relay be in scope? We ask the drafting team to clarify the intent of the definition, chiefly whether all automatic closing, even in the event that a relay is not present, falls under the scope of this standard, as well as our concern regarding the scope of Supervisory relays.

Document Name:

Likes: 0

Dislikes: 0

Chris Mattson - Tacoma Public Utilities (Tacoma, WA) - 5 -

Selected Answer: No

Answer Comment:

Tacoma Power generally agrees with the revised definition of "Automatic Reclosing"; however, Tacoma Power recommends consistently using "supervisory relay(s)" or "supervisory relay(s) or function(s)" among the bulleted Component Types.

Document Name:

Likes: 0

Dislikes: 0

Lee Pedowicz - Northeast Power Coordinating Council - 10 - NPCC

Group Information

Group Name: NPCC--Project 2007-17.4 PRC-005 FERC Order No. 803 Directive - PRC-005-6

Group Member Name	Entity	Region	Segments
Alan Adamson	New York State Reliability Council, LLC	NPCC	10
David Burke	Orange and Rockland Utilities Inc.	NPCC	3
Greg Campoli	New York Independent System Operator	NPCC	2
Gerry Dunbar	Northeast Power Coordinating Council	NPCC	10
Mark Kenny	Northeast Utilities	NPCC	1
Helen Lainis	Independent Electricity System Operator	NPCC	2
Rob Vance	New Brunswick Power Corporation	NPCC	9
Paul Malozewski	Hydro One Networks Inc.	NPCC	1
Bruce Metruck	New York Power Authority	NPCC	6
Lee Pedowicz	Northeast Power Coordinating Council	NPCC	10
David Ramkalawan	Ontario Power Generation, Inc.	NPCC	5
Brian Robinson	Utility Services	NPCC	8
Wayne Sipperly	New York Power Authority	NPCC	5
Edward Bedder	Orange and Rockland Utilities Inc.	NPCC	1
Michael Jones	National Grid	NPCC	1
Brian Shanahan	National Grid	NPCC	1
Glen Smith	Entergy Services, Inc.	NPCC	5
RuiDa Shu	Northeast Power Coordinating Council	NPCC	10
Connie Lowe	Dominion Resources Services, Inc.	NPCC	5

Guy Zito	Northeast Power Coordinating Council	NPCC	10
Silvia Parada Mitchell	NextEra Energy, LLC	NPCC	5
Robert Pellegrini	The United Illuminating Company	NPCC	1
Kathleen Goodman	ISO - New England	NPCC	2
Kelly Dash	Consolidated Edison Co. of New York, Inc.	NPCC	1
Michael Forte	Consolidated Edison Co. of New York, Inc.	NPCC	1
Brian O'Boyle	Consolidated Edison Co. of New York, Inc.	NPCC	8
Peter Yost	Consolidated Edison Co. of New York, Inc.	NPCC	3
Sylvain Clermont	Hydro-Quebec TransEnergie	NPCC	1
Si Truc Phan	Hydro-Quebec TransEnergie	NPCC	1

Voter Information

Voter	Segment
Lee Pedowicz	10
Entity	Region(s)
Northeast Power Coordinating Council	NPCC

Selected Answer: Yes

Answer Comment:

Document Name:

Likes: 0

Dislikes: 0

Jennifer Losacco - NextEra Energy - Florida Power and Light Co. - 1 - FRCC

Selected Answer: Yes

Answer Comment:

Document Name:

Likes: 0

Dislikes: 0

Charles Yeung - Southwest Power Pool, Inc. (RTO) - 2 -

Group Information

Group Name: IRC Standards Review Committee

Group Member Name	Entity	Region	Segments
Charles Yeung	SPP	SPP	2
Ben Li	IESO	NPCC	2
Greg Campoli	NYISO	NPCC	2
Mark Holman	PJM	RFC	2
Matt Goldberg	ISONE	NPCC	2
Lori Spence	MISO	MRO	2
Christina Bigelow	ERCOT	TRE	2
Ali Miremadi	CAISO	WECC	2

Voter Information

Voter	Segment
Charles Yeung	2
Entity	Region(s)
Southwest Power Pool, Inc. (RTO)	

Selected Answer: Yes

Answer Comment: Thank you for the clarification which addresses the SRC's comments on the SAR.

Document Name:

Likes: 0

Dislikes: 0

Jason Smith - Southwest Power Pool, Inc. (RTO) - 2 - SPP

Group Information

Group Name: SPP Standards Review Group

Group Member Name	Entity	Region	Segments
Shannon Mickens	Southwest Power Pool	SPP	2
Jason Smith	Southwest Power Pool	SPP	2
Karl Diekevers	Nebraska Public Power District	MRO	1,3,5
Allan George	Sunflower Electric Power Corporation	SPP	1
Robert Gray	Board of Public Utilities Kansas City, Kansas	SPP	3
Robert Hirschak	CLECO Corporation	SPP	1,3,5,6
Stephanie Johnson	Westar Energy, Inc.	SPP	1,3,5,6
James Nail	City of Independence, Missouri	SPP	3,5
Scott Williams	City Utilities of Springfield	SPP	1,4

Voter Information

Voter **Segment**

Jason Smith 2

Entity **Region(s)**

Southwest Power Pool, Inc. (RTO) SPP

Selected Answer: Yes

Answer Comment:

Document Name:

Likes: 0

Dislikes: 0

Ben Engelby - ACES Power Marketing - 6 -

Group Information

Group Name: ACES Standards Collaborators - PRC-005 Project

Group Member Name	Entity	Region	Segments
Amber Skillern	East Kentucky Power Cooperative	SERC	1,3
Shari Heino	Brazos Electric Power Cooperative, Inc.	TRE	1,5
Bob Solomon	Hoosier Energy Rural Electric Cooperative, Inc.	RFC	1
Mike Brytowski	Great River Energy	MRO	1,3,5,6
Ellen Watkins	Sunflower Electric Power Corporation	SPP	1
Ryan Strom	Buckeye Power, Inc.	RFC	4
Ginger Mercier	Prairie Power, Inc.	SERC	1,3
Lucia Beal	Southern Maryland Electric Cooperative	RFC	3

Voter Information

Voter	Segment
Ben Engelby	6
Entity	Region(s)
ACES Power Marketing	

Selected Answer: Yes

Answer Comment: The definition change is consistent with the FERC directive in Order 803.

Document Name:

Likes: 0

Dislikes: 0

Oshani Pathirane - Oshani Pathirane On Behalf of: Paul Malozewski, Hydro One Networks, Inc., 1, 3
Payam Farahbakhsh, Hydro One Networks, Inc., 1, 3

Selected Answer: Yes

Answer Comment:

With respect to requirements 4.2.7.1 and 4.2.7.2, automatic reclosing relays addressed are subject to an exemption if the owner of the equipment could demonstrate that a close-in three-phase fault present for twice the normal clearing time (capturing a minimum trip-close-trip time delay) does not result in a total loss of gross generation in the Interconnection exceeding the gross capacity of the largest relevant BES generating unit where the Automatic Reclosing is applied. However, Hydro One Networks Inc. would like to suggest that the SDT consider indicating the timelines for demonstrating the above applicability. For example, additional detail on what would trigger a system review, or intervals in which the system review should be performed, could be explicitly stated within the body of the standard.

Document Name:

Likes: 0

Dislikes: 0

2. The PSMTSDT has added Table 4-3 to address maintenance activities and intervals for voltage sensing devices associated with supervisory relays. Do you agree with the proposed table? If not, please provide specific comments regarding the table and any suggestions for alternative language.

John Fontenot - Bryan Texas Utilities - 1 -

Selected Answer: Yes

Answer Comment:

Document Name:

Likes: 0

Dislikes: 0

**Meghan Ferguson - International Transmission Company Holdings Corporation On Behalf of:
Michael Moltane, International Transmission Company Holdings Corporation, 1**

Selected Answer: No

Answer Comment:

The note on Table 4-3 needs to be updated with the correct information and table reference.

Currently, the Note on Table 4-3 reads: *"Note: In cases where **Components of Sudden Pressure Relaying** are common to Components listed in **Table 1** , the Components only need to be tested once during a distinct maintenance interval."*

The Note on Table 4-3 should be re-worded as: *"Note: In cases where **Automatic Reclosing Components** are common to Components listed in **Table 1** , the Components only need to be tested once during a distinct maintenance interval."*

Document Name:

Likes: 0

Dislikes: 0

Barbara Kedrowski - WEC Energy Group, Inc. - 3,4,5 - RFC

Selected Answer:

Answer Comment:

Document Name:

Likes: 0

Dislikes: 0

Andrew Pusztai - American Transmission Company, LLC - 1 -

Selected Answer: Yes

Answer Comment:

Document Name:

Likes: 0

Dislikes: 0

Thomas Foltz - AEP - 5 -

Selected Answer: Yes

Answer Comment:

Document Name:

Likes: 0

Dislikes: 0

Jamison Dye - Bonneville Power Administration - 1,3,5,6 - WECC

Selected Answer: Yes

Answer Comment:

Document Name:

Likes: 0

Dislikes: 0

Leonard Kula - Independent Electricity System Operator - 2 -

Selected Answer: Yes

Answer Comment:

Document Name:

Likes: 0

Dislikes: 0

Emily Rousseau - MRO - 1,2,3,4,5,6 - MRO

Group Information

Group Name: MRO-NERC Standards Review Forum (NSRF)

Group Member Name	Entity	Region	Segments
Joe Depoorter	Madison Gas & Electric	MRO	3,4,5,6
Amy Casucelli	Xcel Energy	MRO	1,3,5,6
Chuck Lawrence	American Transmission Company	MRO	1
Chuck Wicklund	Otter Tail Power Company	MRO	1,3,5
Theresa Allard	Minnkota Power Cooperative, Inc	MRO	1,3,5,6
Dave Rudolph	Basin Electric Power Cooperative	MRO	1,3,5,6
Kayleigh Wilkerson	Lincoln Electric System	MRO	1,3,5,6
Jodi Jenson	Western Area Power Administration	MRO	1,6
Larry Heckert	Alliant Energy	MRO	4
Mahmood Safi	Omaha Public Utility District	MRO	1,3,5,6
Shannon Weaver	Midwest ISO Inc.	MRO	2
Mike Brytowski	Great River Energy	MRO	1,3,5,6
Brad Perrett	Minnesota Power	MRO	1,5
Scott Nickels	Rochester Public Utilities	MRO	4
Terry Harbour	MidAmerican Energy Company	MRO	1,3,5,6
Tom Breene	Wisconsin Public Service Corporation	MRO	3,4,5,6
Tony Eddleman	Nebraska Public Power District	MRO	1,3,5

Voter Information

Voter	Segment
Emily Rousseau	1,2,3,4,5,6
Entity	Region(s)
MRO	MRO

Selected Answer: Yes

Answer Comment:

Document Name:

Likes: 0

Dislikes: 0

Gul Khan - Gul Khan On Behalf of: Rod Kinard, Oncor Electric Delivery, 1

Selected Answer: Yes

Answer Comment:

Document Name:

Likes: 0

Dislikes: 0

Amy Casuscelli - Xcel Energy, Inc. - 1,3,5,6 - MRO,WECC,SPP

Selected Answer: Yes

Answer Comment:

Document Name:

Likes: 0

Dislikes: 0

Adam Padgett - TECO - Tampa Electric Co. - 1,3,4,5 - FRCC

Selected Answer: Yes

Answer Comment:

Document Name:

Likes: 0

Dislikes: 0

Pamela Hunter - Southern Company - Southern Company Services, Inc. - 1,3,5,6 - SERC

Group Information

Group Name: Southern Company

Group Member Name	Entity	Region	Segments
Robert A. Schaffeld	Southern Company Services, Inc.	SERC	1
R. Scott Moore	Alabama Power Company	SERC	3
William D. Shultz	Southern Company Generation	SERC	5
John J. Ciza	Southern Company Generation and Energy Marketing	SERC	6

Voter Information

Voter **Segment**

Pamela Hunter 1,3,5,6

Entity **Region(s)**

Southern Company - Southern Company Services, Inc. SERC

Selected Answer:

Answer Comment:

Document Name:

Likes: 0

Dislikes: 0

John Fontenot - Bryan Texas Utilities - 1 -

Selected Answer: Yes

Answer Comment:

Document Name:

Likes: 0

Dislikes: 0

John Fontenot - Bryan Texas Utilities - 1 -

Selected Answer: Yes

Answer Comment:

Document Name:

Likes: 0

Dislikes: 0

John Coggins - Salt River Project - 3 -

Selected Answer: Yes

Answer Comment:

Document Name:

Likes: 0

Dislikes: 0

Molly Devine - IDACORP - Idaho Power Company - 1 -

Selected Answer: Yes

Answer Comment:

Document Name:

Likes: 0

Dislikes: 0

Rachel Coyne - Texas Reliability Entity, Inc. - 10 -

Selected Answer: No

Answer Comment:

Texas RE inquires as to why the standard drafting team choose 12 years for this Component Type. In general, in most, not all, of the previous Tables provided for maintenance activities of any unmonitored relay had a 6 Calendar Year Minimum Maintenance Interval.

Texas RE noticed Maintenance Activities of Table 4-1 are not consistent (e.g.- Row 1 states "Verify that settings are as specified" but Row 2 states "Verify: Settings are as specified" (in bullets) but the format is backwards for the "Operation of the relay inputs..." statement in both rows.

Additional clarity may be needed between the Table 4-1 additions and Table 4-3. In Table 4-1 there is a Component Attribute for supervisory relays that essentially states a 12 Calendar Year Maximum Maintenance Interval for supervisory relays that have “AC measurements are continuously verified by comparison to an independent AC measurement source, with alarming for excessive error (See Table 2).” In Table 4-3 “Voltage sensing devices that are connected to microprocessor supervisory relays with AC measurements that are continuously verified by comparison of sensing input value, as measured by the microprocessor relay, to an independent AC measurement source, with alarming for unacceptable error or failure. (See Table 2)” has no periodic maintenance specified. Texas RE is concerned it appears an entity is required to do the “Maintenance Activity” described in Table 4-1 (“Verify acceptable measurement of power system input values.”) within 12 Calendar Years on the relays but is not required to do any Maintenance Activity on the voltage sensing devices.

Document Name:

Likes: 0

Dislikes: 0

John Seelke - PSEG - 1,3,5,6 - NPCC,RFC

Group Information

Group Name: PSEG

Group Member Name	Entity	Region	Segments
Joseph Smith	Public Service Electric and Gas	RFC	1
Jeffrey Mueller	Public Service Electric and Gas Co.	RFC	3
Tim Kucey	PSEG Fossil LLC	RFC	5
Karla Jara	PSEG Energy Resources & Trade LLC	RFC	6

Voter Information

Voter	Segment
John Seelke	1,3,5,6
Entity	Region(s)
PSEG	NPCC,RFC

Selected Answer: No

Answer Comment: We do not believe this standard is needed.

Document Name:

Likes: 2 PSEG - Public Service Electric and Gas Co., 1, Smith Joseph
PSEG - PSEG Fossil LLC, 5, Kucey Tim

Dislikes: 0

Mike Smith - Manitoba Hydro - 1 -

Selected Answer: Yes

Answer Comment:

Document Name:

Likes: 0

Dislikes: 0

David Jendras - Ameren - Ameren Services - 3 -

Selected Answer: Yes

Answer Comment:

Document Name:

Likes: 0

Dislikes: 0

Colby Bellville - Duke Energy - 1,3,5,6 - FRCC,SERC,RFC

Group Information

Group Name: Duke Energy

Group Member Name	Entity	Region	Segments
Doug Hils	Duke Energy	RFC	1
Lee Schuster	Duke Energy	FRCC	3
Dale Goodwine	Duke Energy	SERC	5
Greg Cecil	Duke Energy	RFC	6

Voter Information

Voter	Segment
Colby Bellville	1,3,5,6
Entity	Region(s)
Duke Energy	FRCC,SERC,RFC

Selected Answer: Yes

Answer Comment: Duke Energy is unsure of the necessity of inserting the note: “Note: In cases where Components of Sudden Pressure Relaying are common to Components listed in Table 1-5, the Components only need to be tested once during a distinct maintenance interval” to Table 4-3. It doesn’t appear that the note is applicable to this Table. We recommend that the drafting team consider only including the Note on tables where it is best applicable.

Document Name:

Likes: 0

Dislikes: 0

Chris Mattson - Tacoma Public Utilities (Tacoma, WA) - 5 -

Selected Answer: Yes

Answer Comment:

In Tables 4-2(a), 4-2(b), and 4-3, "Sudden Pressure Relaying" should be changed to "Automatic Reclosing."

Document Name:

Likes: 0

Dislikes: 0

Lee Pedowicz - Northeast Power Coordinating Council - 10 - NPCC

Group Information

Group Name: NPCC--Project 2007-17.4 PRC-005 FERC Order No. 803 Directive - PRC-005-6

Group Member Name	Entity	Region	Segments
Alan Adamson	New York State Reliability Council, LLC	NPCC	10
David Burke	Orange and Rockland Utilities Inc.	NPCC	3
Greg Campoli	New York Independent System Operator	NPCC	2
Gerry Dunbar	Northeast Power Coordinating Council	NPCC	10
Mark Kenny	Northeast Utilities	NPCC	1
Helen Lainis	Independent Electricity System Operator	NPCC	2
Rob Vance	New Brunswick Power Corporation	NPCC	9
Paul Malozewski	Hydro One Networks Inc.	NPCC	1
Bruce Metruck	New York Power Authority	NPCC	6
Lee Pedowicz	Northeast Power Coordinating Council	NPCC	10
David Ramkalawan	Ontario Power Generation, Inc.	NPCC	5
Brian Robinson	Utility Services	NPCC	8
Wayne Sipperly	New York Power Authority	NPCC	5
Edward Bedder	Orange and Rockland Utilities Inc.	NPCC	1
Michael Jones	National Grid	NPCC	1
Brian Shanahan	National Grid	NPCC	1
Glen Smith	Entergy Services, Inc.	NPCC	5
RuiDa Shu	Northeast Power Coordinating Council	NPCC	10
Connie Lowe	Dominion Resources Services, Inc.	NPCC	5

Guy Zito	Northeast Power Coordinating Council	NPCC	10
Silvia Parada Mitchell	NextEra Energy, LLC	NPCC	5
Robert Pellegrini	The United Illuminating Company	NPCC	1
Kathleen Goodman	ISO - New England	NPCC	2
Kelly Dash	Consolidated Edison Co. of New York, Inc.	NPCC	1
Michael Forte	Consolidated Edison Co. of New York, Inc.	NPCC	1
Brian O'Boyle	Consolidated Edison Co. of New York, Inc.	NPCC	8
Peter Yost	Consolidated Edison Co. of New York, Inc.	NPCC	3
Sylvain Clermont	Hydro-Quebec TransEnergie	NPCC	1
Si Truc Phan	Hydro-Quebec TransEnergie	NPCC	1

Voter Information

Voter	Segment
Lee Pedowicz	10
Entity	Region(s)
Northeast Power Coordinating Council	NPCC

Selected Answer: Yes

Answer Comment:

Document Name:

Likes: 0

Dislikes: 0

Jennifer Losacco - NextEra Energy - Florida Power and Light Co. - 1 - FRCC

Selected Answer: Yes

Answer Comment:

Document Name:

Likes: 0

Dislikes: 0

Charles Yeung - Southwest Power Pool, Inc. (RTO) - 2 -

Group Information

Group Name: IRC Standards Review Committee

Group Member Name	Entity	Region	Segments
Charles Yeung	SPP	SPP	2
Ben Li	IESO	NPCC	2
Greg Campoli	NYISO	NPCC	2
Mark Holman	PJM	RFC	2
Matt Goldberg	ISONE	NPCC	2
Lori Spence	MISO	MRO	2
Christina Bigelow	ERCOT	TRE	2
Ali Miremadi	CAISO	WECC	2

Voter Information

Voter	Segment
Charles Yeung	2
Entity	Region(s)
Southwest Power Pool, Inc. (RTO)	

Selected Answer:

Answer Comment:

Document Name:

Likes: 0

Dislikes: 0

Jason Smith - Southwest Power Pool, Inc. (RTO) - 2 - SPP

Group Information

Group Name: SPP Standards Review Group

Group Member Name	Entity	Region	Segments
Shannon Mickens	Southwest Power Pool	SPP	2
Jason Smith	Southwest Power Pool	SPP	2
Karl Diekevers	Nebraska Public Power District	MRO	1,3,5
Allan George	Sunflower Electric Power Corporation	SPP	1
Robert Gray	Board of Public Utilities Kansas City, Kansas	SPP	3
Robert Hirschak	CLECO Corporation	SPP	1,3,5,6
Stephanie Johnson	Westar Energy, Inc.	SPP	1,3,5,6
James Nail	City of Independence, Missouri	SPP	3,5
Scott Williams	City Utilities of Springfield	SPP	1,4

Voter Information

Voter **Segment**

Jason Smith 2

Entity **Region(s)**

Southwest Power Pool, Inc. (RTO) SPP

Selected Answer: Yes

Answer Comment:

Document Name:

Likes: 0

Dislikes: 0

Ben Engelby - ACES Power Marketing - 6 -

Group Information

Group Name: ACES Standards Collaborators - PRC-005 Project

Group Member Name	Entity	Region	Segments
Amber Skillern	East Kentucky Power Cooperative	SERC	1,3
Shari Heino	Brazos Electric Power Cooperative, Inc.	TRE	1,5
Bob Solomon	Hoosier Energy Rural Electric Cooperative, Inc.	RFC	1
Mike Brytowski	Great River Energy	MRO	1,3,5,6
Ellen Watkins	Sunflower Electric Power Corporation	SPP	1
Ryan Strom	Buckeye Power, Inc.	RFC	4
Ginger Mercier	Prairie Power, Inc.	SERC	1,3
Lucia Beal	Southern Maryland Electric Cooperative	RFC	3

Voter Information

Voter	Segment
Ben Engelby	6
Entity	Region(s)
ACES Power Marketing	

Selected Answer: Yes

Answer Comment:

We identified a minor grammatical error in Table 1-1. There is inconsistent capitalization of the acronym "AC" in the first bullet, which lists both "Ac" and "AC".

We ask the drafting team to clarify in Table 4-1 the phrase "with preceding row attributes," as the format of the table is unclear whether the reference is to all of the monitored microprocessor reclosing relays and supervisory relays, including Table 2, or just the supervisory relays with waveform sampling three or more

times per power cycle. The format of each table carrying over the header from the previous page makes the phrase “with preceding row attributes” unclear.

We appreciate the drafting team providing clarity in the note of Table 4-3 for cases where Components of Sudden Pressure Relaying are common to Components listed in Table 1 during a distinct maintenance interval.

-5,

Document Name:

Likes: 0

Dislikes: 0

Oshani Pathirane - Oshani Pathirane On Behalf of: Paul Malozewski, Hydro One Networks, Inc., 1, 3
Payam Farahbakhsh, Hydro One Networks, Inc., 1, 3

Selected Answer: No

Answer Comment:

Hydro One Networks Inc. would like to suggest that, the wording of the title bar's note be changed to read, "In cases where ***Automatic Reclosing Components*** are common to Components listed in ***Tables 1-3 and 1-5***, the Components only need to be tested once during a distinct maintenance interval."

Hydro One Networks Inc. would also like to suggest that Tables 4-2(a) and 4-2(b) title bars' notes also be revised to read, "Automatic Reclosing Components", instead of "Sudden Pressure Relaying"

Document Name:

Likes: 0

Dislikes: 0

3. The PSMTSDT has made revisions to the Supplementary Reference and FAQ Document. Do you agree with the proposed revisions? If not, please provide specific comments regarding the revisions and any suggestions for alternative language.

John Fontenot - Bryan Texas Utilities - 1 -

Selected Answer: Yes

Answer Comment:

Document Name:

Likes: 0

Dislikes: 0

**Meghan Ferguson - International Transmission Company Holdings Corporation On Behalf of:
Michael Moltane, International Transmission Company Holdings Corporation, 1**

Selected Answer: Yes

Answer Comment:

Document Name:

Likes: 0

Dislikes: 0

Barbara Kedrowski - WEC Energy Group, Inc. - 3,4,5 - RFC

Selected Answer:

Answer Comment:

Document Name:

Likes: 0

Dislikes: 0

Andrew Puztai - American Transmission Company, LLC - 1 -

Selected Answer: Yes

Answer Comment:

However, in the draft standard, the terms, "AC" and "DC" are capitalized. However, in the FAQ Document, "ac" and "dc" are lower case. ATC recommends using capitalization (or lack thereof) related to "AC" and "DC" consistently in both the standard and the FAQ Document.

Document Name:

Likes: 0

Dislikes: 0

Thomas Foltz - AEP - 5 -

Selected Answer: Yes

Answer Comment:

Document Name:

Likes: 0

Dislikes: 0

Jamison Dye - Bonneville Power Administration - 1,3,5,6 - WECC

Selected Answer: Yes

Answer Comment:

Document Name:

Likes: 0

Dislikes: 0

Leonard Kula - Independent Electricity System Operator - 2 -

Selected Answer: Yes

Answer Comment:

Document Name:

Likes: 0

Dislikes: 0

Emily Rousseau - MRO - 1,2,3,4,5,6 - MRO

Group Information

Group Name: MRO-NERC Standards Review Forum (NSRF)

Group Member Name	Entity	Region	Segments
Joe Depoorter	Madison Gas & Electric	MRO	3,4,5,6
Amy Casucelli	Xcel Energy	MRO	1,3,5,6
Chuck Lawrence	American Transmission Company	MRO	1
Chuck Wicklund	Otter Tail Power Company	MRO	1,3,5
Theresa Allard	Minnkota Power Cooperative, Inc	MRO	1,3,5,6
Dave Rudolph	Basin Electric Power Cooperative	MRO	1,3,5,6
Kayleigh Wilkerson	Lincoln Electric System	MRO	1,3,5,6
Jodi Jenson	Western Area Power Administration	MRO	1,6
Larry Heckert	Alliant Energy	MRO	4
Mahmood Safi	Omaha Public Utility District	MRO	1,3,5,6
Shannon Weaver	Midwest ISO Inc.	MRO	2
Mike Brytowski	Great River Energy	MRO	1,3,5,6
Brad Perrett	Minnesota Power	MRO	1,5
Scott Nickels	Rochester Public Utilities	MRO	4
Terry Harbour	MidAmerican Energy Company	MRO	1,3,5,6
Tom Breene	Wisconsin Public Service Corporation	MRO	3,4,5,6
Tony Eddleman	Nebraska Public Power District	MRO	1,3,5

Voter Information

Voter	Segment
Emily Rousseau	1,2,3,4,5,6
Entity	Region(s)
MRO	MRO

Selected Answer: Yes

Answer Comment:

Document Name:

Likes: 0

Dislikes: 0

Gul Khan - Gul Khan On Behalf of: Rod Kinard, Oncor Electric Delivery, 1

Selected Answer: Yes

Answer Comment:

Document Name:

Likes: 0

Dislikes: 0

Amy Casuscelli - Xcel Energy, Inc. - 1,3,5,6 - MRO,WECC,SPP

Selected Answer: Yes

Answer Comment:

Document Name:

Likes: 0

Dislikes: 0

Adam Padgett - TECO - Tampa Electric Co. - 1,3,4,5 - FRCC

Selected Answer: Yes

Answer Comment:

Document Name:

Likes: 0

Dislikes: 0

Pamela Hunter - Southern Company - Southern Company Services, Inc. - 1,3,5,6 - SERC

Group Information

Group Name: Southern Company

Group Member Name	Entity	Region	Segments
Robert A. Schaffeld	Southern Company Services, Inc.	SERC	1
R. Scott Moore	Alabama Power Company	SERC	3
William D. Shultz	Southern Company Generation	SERC	5
John J. Ciza	Southern Company Generation and Energy Marketing	SERC	6

Voter Information

Voter **Segment**

Pamela Hunter 1,3,5,6

Entity **Region(s)**

Southern Company - Southern Company Services, Inc. SERC

Selected Answer:

Answer Comment:

Document Name:

Likes: 0

Dislikes: 0

John Fontenot - Bryan Texas Utilities - 1 -

Selected Answer: Yes

Answer Comment:

Document Name:

Likes: 0

Dislikes: 0

John Fontenot - Bryan Texas Utilities - 1 -

Selected Answer: Yes

Answer Comment:

Document Name:

Likes: 0

Dislikes: 0

John Coggins - Salt River Project - 3 -

Selected Answer: Yes

Answer Comment:

Document Name:

Likes: 0

Dislikes: 0

Molly Devine - IDACORP - Idaho Power Company - 1 -

Selected Answer: Yes

Answer Comment:

Document Name:

Likes: 0

Dislikes: 0

Rachel Coyne - Texas Reliability Entity, Inc. - 10 -

Selected Answer:

Answer Comment:

Texas RE noticed some references to version four of PRC-005, which could cause confusion:

- Page four in the first paragraph, "PRC-005-4 would apply to this equipment"; and
- Page Five in the FAQ section regarding Distribution Provider.

On page 20 of the Supplementary document there is a reference to CBM that appears incorrect ("if the condition of the device is continuously monitored (CBM).")

Document Name:

Likes: 0

Dislikes: 0

John Seelke - PSEG - 1,3,5,6 - NPCC,RFC

Group Information

Group Name: PSEG

Group Member Name	Entity	Region	Segments
Joseph Smith	Public Service Electric and Gas	RFC	1
Jeffrey Mueller	Public Service Electric and Gas Co.	RFC	3
Tim Kucey	PSEG Fossil LLC	RFC	5
Karla Jara	PSEG Energy Resources & Trade LLC	RFC	6

Voter Information

Voter	Segment
John Seelke	1,3,5,6
Entity	Region(s)
PSEG	NPCC,RFC

Selected Answer: No

Answer Comment: We do not believe this standard is needed.

Document Name:

Likes: 2 PSEG - Public Service Electric and Gas Co., 1, Smith Joseph
PSEG - PSEG Fossil LLC, 5, Kucey Tim

Dislikes: 0

Mike Smith - Manitoba Hydro - 1 -

Selected Answer: Yes

Answer Comment:

Document Name:

Likes: 0

Dislikes: 0

David Jendras - Ameren - Ameren Services - 3 -

Selected Answer: Yes

Answer Comment:

Document Name:

Likes: 0

Dislikes: 0

Colby Bellville - Duke Energy - 1,3,5,6 - FRCC,SERC,RFC

Group Information

Group Name: Duke Energy

Group Member Name	Entity	Region	Segments
Doug Hils	Duke Energy	RFC	1
Lee Schuster	Duke Energy	FRCC	3
Dale Goodwine	Duke Energy	SERC	5
Greg Cecil	Duke Energy	RFC	6

Voter Information

Voter	Segment
Colby Bellville	1,3,5,6
Entity	Region(s)
Duke Energy	FRCC,SERC,RFC

Selected Answer:

Answer Comment:

Document Name:

Likes: 0

Dislikes: 0

Chris Mattson - Tacoma Public Utilities (Tacoma, WA) - 5 -

Selected Answer:

Answer Comment:

On page 24 of the redlined version of the Supplementary Reference and FAQ, the bottom box in the flowchart should show R5, not R3.

Document Name:

Likes: 0

Dislikes: 0

Lee Pedowicz - Northeast Power Coordinating Council - 10 - NPCC

Group Information

Group Name: NPCC--Project 2007-17.4 PRC-005 FERC Order No. 803 Directive - PRC-005-6

Group Member Name	Entity	Region	Segments
Alan Adamson	New York State Reliability Council, LLC	NPCC	10
David Burke	Orange and Rockland Utilities Inc.	NPCC	3
Greg Campoli	New York Independent System Operator	NPCC	2
Gerry Dunbar	Northeast Power Coordinating Council	NPCC	10
Mark Kenny	Northeast Utilities	NPCC	1
Helen Lainis	Independent Electricity System Operator	NPCC	2
Rob Vance	New Brunswick Power Corporation	NPCC	9
Paul Malozewski	Hydro One Networks Inc.	NPCC	1
Bruce Metruck	New York Power Authority	NPCC	6
Lee Pedowicz	Northeast Power Coordinating Council	NPCC	10
David Ramkalawan	Ontario Power Generation, Inc.	NPCC	5
Brian Robinson	Utility Services	NPCC	8
Wayne Sipperly	New York Power Authority	NPCC	5
Edward Bedder	Orange and Rockland Utilities Inc.	NPCC	1
Michael Jones	National Grid	NPCC	1
Brian Shanahan	National Grid	NPCC	1
Glen Smith	Entergy Services, Inc.	NPCC	5
RuiDa Shu	Northeast Power Coordinating Council	NPCC	10
Connie Lowe	Dominion Resources Services, Inc.	NPCC	5

Guy Zito	Northeast Power Coordinating Council	NPCC	10
Silvia Parada Mitchell	NextEra Energy, LLC	NPCC	5
Robert Pellegrini	The United Illuminating Company	NPCC	1
Kathleen Goodman	ISO - New England	NPCC	2
Kelly Dash	Consolidated Edison Co. of New York, Inc.	NPCC	1
Michael Forte	Consolidated Edison Co. of New York, Inc.	NPCC	1
Brian O'Boyle	Consolidated Edison Co. of New York, Inc.	NPCC	8
Peter Yost	Consolidated Edison Co. of New York, Inc.	NPCC	3
Sylvain Clermont	Hydro-Quebec TransEnergie	NPCC	1
Si Truc Phan	Hydro-Quebec TransEnergie	NPCC	1

Voter Information

Voter	Segment
Lee Pedowicz	10
Entity	Region(s)
Northeast Power Coordinating Council	NPCC

Selected Answer: No

Answer Comment:

Suggest a clarification in the definition of a synchronizing or synchronism check relay (Sync-Check - 25) as shown below:

“A synchronizing device that produces an output that supervises closure of a circuit breaker between two circuits whose voltages are within prescribed limits of magnitude and within the prescribed phase angle **for the prescribed time**. It may or may not include voltage or speed control. A sync-check relay permits the paralleling of two circuits that are within prescribed (usually wider) limits of voltage magnitude and phase angle **for the prescribed time**.”

Document Name:

Likes: 1 Pathirane Oshani On Behalf of: Paul Malozewski, Hydro One Networks, Inc.,
1, 3,
Payam Farahbakhsh

Dislikes: 0

Jennifer Losacco - NextEra Energy - Florida Power and Light Co. - 1 - FRCC

Selected Answer: Yes

Answer Comment:

Document Name:

Likes: 0

Dislikes: 0

Charles Yeung - Southwest Power Pool, Inc. (RTO) - 2 -

Group Information

Group Name: IRC Standards Review Committee

Group Member Name	Entity	Region	Segments
Charles Yeung	SPP	SPP	2
Ben Li	IESO	NPCC	2
Greg Campoli	NYISO	NPCC	2
Mark Holman	PJM	RFC	2
Matt Goldberg	ISONE	NPCC	2
Lori Spence	MISO	MRO	2
Christina Bigelow	ERCOT	TRE	2
Ali Miremadi	CAISO	WECC	2

Voter Information

Voter	Segment
Charles Yeung	2
Entity	Region(s)
Southwest Power Pool, Inc. (RTO)	

Selected Answer:

Answer Comment:

Document Name:

Likes: 0

Dislikes: 0

Jason Smith - Southwest Power Pool, Inc. (RTO) - 2 - SPP

Group Information

Group Name: SPP Standards Review Group

Group Member Name	Entity	Region	Segments
Shannon Mickens	Southwest Power Pool	SPP	2
Jason Smith	Southwest Power Pool	SPP	2
Karl Diekevers	Nebraska Public Power District	MRO	1,3,5
Allan George	Sunflower Electric Power Corporation	SPP	1
Robert Gray	Board of Public Utilities Kansas City, Kansas	SPP	3
Robert Hirschak	CLECO Corporation	SPP	1,3,5,6
Stephanie Johnson	Westar Energy, Inc.	SPP	1,3,5,6
James Nail	City of Independence, Missouri	SPP	3,5
Scott Williams	City Utilities of Springfield	SPP	1,4

Voter Information

Voter Segment

Jason Smith 2

Entity Region(s)

Southwest Power Pool, Inc. (RTO) SPP

Selected Answer: Yes

Answer Comment:

Document Name:

Likes: 0

Dislikes: 0

Ben Engelby - ACES Power Marketing - 6 -

Group Information

Group Name: ACES Standards Collaborators - PRC-005 Project

Group Member Name	Entity	Region	Segments
Amber Skillern	East Kentucky Power Cooperative	SERC	1,3
Shari Heino	Brazos Electric Power Cooperative, Inc.	TRE	1,5
Bob Solomon	Hoosier Energy Rural Electric Cooperative, Inc.	RFC	1
Mike Brytowski	Great River Energy	MRO	1,3,5,6
Ellen Watkins	Sunflower Electric Power Corporation	SPP	1
Ryan Strom	Buckeye Power, Inc.	RFC	4
Ginger Mercier	Prairie Power, Inc.	SERC	1,3
Lucia Beal	Southern Maryland Electric Cooperative	RFC	3

Voter Information

Voter	Segment
Ben Engelby	6
Entity	Region(s)
ACES Power Marketing	

Selected Answer: Yes

Answer Comment:

We generally agree with the document, but question the need for listing PRC-005, PRC-008, PRC-011, and PRC-017 in the introduction. This only creates confusion and will need to be revised when these standards are retired. The implementation plan already covers these changes. The introduction should explain the various FERC orders and the rationale for adding additional equipment to the scope of this standard. While we understand that the supplementary reference is not mandatory nor enforceable, it should be drafted in a way that does not require constant updates or maintenance for each new version of the standard.

On page 98, the newly added FAQ regarding the parts of the control circuitry that need to be verified should clarify that the numbers listed in the bullets are IEEE device numbers. Also, the format of this question makes it appear that all of the bullets are applicable and need to be verified. The reader must get to the final sentence before they find that three of the six bullets do not need verification. We ask the SDT to reword this question by removing the bullets and clarifying that IEEE device numbers 79, 25, and 27 or 59 would need to be verified while IEEE device numbers 79/ON, 52, and 86 do not.

We identified inconsistent capitalization for “AC,” “DC,” and “VAR”. The standard capitalizes these words while the technical reference does not. We recommend that the supplemental reference matches the same usage and capitalization as the standard.

Document Name:

Likes: 0

Dislikes: 0

Oshani Pathirane - Oshani Pathirane On Behalf of: Paul Malozewski, Hydro One Networks, Inc., 1, 3
Payam Farahbakhsh, Hydro One Networks, Inc., 1, 3

Selected Answer: Yes

Answer Comment:

Document Name:

Likes: 0

Dislikes: 0

4. The PSMTSDT has proposed combining the Implementation Plans for previous versions of PRC-005 (including PRC-005-3, PRC-005-3i, PRC-005-3ii, PRC-005-4 and PRC-005-5). Do you agree with the proposed Implementation Plan? If not, please provide specific comments regarding the Implementation Plan and any suggestions for alternative language.

John Fontenot - Bryan Texas Utilities - 1 -

Selected Answer: Yes

Answer Comment:

Document Name:

Likes: 0

Dislikes: 0

**Meghan Ferguson - International Transmission Company Holdings Corporation On Behalf of:
Michael Moltane, International Transmission Company Holdings Corporation, 1**

Selected Answer: Yes

Answer Comment:

Document Name:

Likes: 0

Dislikes: 0

Barbara Kedrowski - WEC Energy Group, Inc. - 3,4,5 - RFC

Selected Answer:

Answer Comment:

Document Name:

Likes: 0

Dislikes: 0

Andrew Puztai - American Transmission Company, LLC - 1 -

Selected Answer: Yes

Answer Comment:

Document Name:

Likes: 0

Dislikes: 0

Thomas Foltz - AEP - 5 -

Selected Answer: Yes

Answer Comment:

Document Name:

Likes: 0

Dislikes: 0

Jamison Dye - Bonneville Power Administration - 1,3,5,6 - WECC

Selected Answer: Yes

Answer Comment:

Document Name:

Likes: 0

Dislikes: 0

Leonard Kula - Independent Electricity System Operator - 2 -

Selected Answer: Yes

Answer Comment:

Document Name:

Likes: 0

Dislikes: 0

Emily Rousseau - MRO - 1,2,3,4,5,6 - MRO

Group Information

Group Name: MRO-NERC Standards Review Forum (NSRF)

Group Member Name	Entity	Region	Segments
Joe Depoorter	Madison Gas & Electric	MRO	3,4,5,6
Amy Casucelli	Xcel Energy	MRO	1,3,5,6
Chuck Lawrence	American Transmission Company	MRO	1
Chuck Wicklund	Otter Tail Power Company	MRO	1,3,5
Theresa Allard	Minnkota Power Cooperative, Inc	MRO	1,3,5,6
Dave Rudolph	Basin Electric Power Cooperative	MRO	1,3,5,6
Kayleigh Wilkerson	Lincoln Electric System	MRO	1,3,5,6
Jodi Jenson	Western Area Power Administration	MRO	1,6
Larry Heckert	Alliant Energy	MRO	4
Mahmood Safi	Omaha Public Utility District	MRO	1,3,5,6
Shannon Weaver	Midwest ISO Inc.	MRO	2
Mike Brytowski	Great River Energy	MRO	1,3,5,6
Brad Perrett	Minnesota Power	MRO	1,5
Scott Nickels	Rochester Public Utilities	MRO	4
Terry Harbour	MidAmerican Energy Company	MRO	1,3,5,6
Tom Breene	Wisconsin Public Service Corporation	MRO	3,4,5,6
Tony Eddleman	Nebraska Public Power District	MRO	1,3,5

Voter Information

Voter	Segment
Emily Rousseau	1,2,3,4,5,6
Entity	Region(s)
MRO	MRO

Selected Answer: No

Answer Comment:

The NSRF suggest the following up date as we believe it was a cut and paste error.

Tables 4-2(a), 4-2(b) and 4-3 have a note contained within the header that needs to be corrected. The note states "Note: In cases where Components of **Sudden Pressure Relaying** are common to Components listed in Table..."

The notes in these tables should be changed from Sudden Pressure Relaying to Automatic Reclosing.

Document Name:

Likes: 0

Dislikes: 0

Gul Khan - Gul Khan On Behalf of: Rod Kinard, Oncor Electric Delivery, 1

Selected Answer: Yes

Answer Comment:

Document Name:

Likes: 0

Dislikes: 0

Amy Casuscelli - Xcel Energy, Inc. - 1,3,5,6 - MRO,WECC,SPP

Selected Answer: Yes

Answer Comment:

We strongly support the consolidation of the various PRC-005 Implementation Plans and believe this effort will eliminate much confusion and provide for a much more manageable change process.

Document Name:

Likes: 0

Dislikes: 0

Adam Padgett - TECO - Tampa Electric Co. - 1,3,4,5 - FRCC

Selected Answer: Yes

Answer Comment:

Eliminating multiple revisions of this standard will facilitate improved understandability of the standard while reducing the potential for errors in implementing the standard.

Document Name:

Likes: 0

Dislikes:

0

Pamela Hunter - Southern Company - Southern Company Services, Inc. - 1,3,5,6 - SERC

Group Information

Group Name: Southern Company

Group Member Name	Entity	Region	Segments
Robert A. Schaffeld	Southern Company Services, Inc.	SERC	1
R. Scott Moore	Alabama Power Company	SERC	3
William D. Shultz	Southern Company Generation	SERC	5
John J. Ciza	Southern Company Generation and Energy Marketing	SERC	6

Voter Information

Voter Segment

Pamela Hunter 1,3,5,6

Entity Region(s)

Southern Company - Southern Company Services, Inc. SERC

Selected Answer:

Answer Comment:

Southern Company supports the proposed implementation plan but, as noted early, feel that the the enforcement date of the already approved PRC-005-3 should immediately be placed on hold in order to coincide with the approval of this version of PRC-005.

Document Name:

Likes: 0

Dislikes: 0

John Fontenot - Bryan Texas Utilities - 1 -

Selected Answer: Yes

Answer Comment:

Document Name:

Likes: 0

Dislikes: 0

John Fontenot - Bryan Texas Utilities - 1 -

Selected Answer: Yes

Answer Comment:

Document Name:

Likes: 0

Dislikes: 0

John Coggins - Salt River Project - 3 -

Selected Answer: Yes

Answer Comment:

Document Name:

Likes: 0

Dislikes: 0

Molly Devine - IDACORP - Idaho Power Company - 1 -

Selected Answer: Yes

Answer Comment:

With the number of revisions, keeping track is becoming a full time job.

Document Name:

Likes: 0

Dislikes: 0

Rachel Coyne - Texas Reliability Entity, Inc. - 10 -

Selected Answer: No

Answer Comment:

Texas RE understands registered entities need time to implement standards, but the extended timeframes for testing and maintenance of the components in the series of standards listed above is too long. If registered entities are aware of the future need they should already be working to identify the Components (and associated maintenance schedules). Texas RE is concerned there would be significant reliability risk if a registered entity was not maintaining a list of the relays it has implemented and when testing was completed on those implemented relays. The extended timeframe, now possibly beyond 2030, could lead to misinterpretations and inconsistencies in registered entities practices and could impact auditing.

Texas RE made the following additional observations:

- There does not appear to be consistent use and applicability of relay types associated with term “relay” (e.g. In Table 4-1 there is a distinction made in Row 1 (page 34) between “microprocessor relays” and “non-microprocessor relays” AND “microprocessor supervisory relays”.) This could lead to confusion. If there is a “non-microprocessor supervisory relay” does an entity need to “Test and, if necessary calibrate”? It appears that verification requirements will apply to reclosing and supervisory relays and an additional requirement for microprocessor supervisory relays has been added. Is that the intent? In Row 2, no distinction is made (i.e. “Verify: Settings are as specified” will apply to both reclosing relays and supervisory relays);
- Section 1.3 “Compliance Monitoring and Assessment Processes” does not follow the Standards template; and
- In Table 3 “Ac” at the beginning of a sentence on page 32 needs capitalized Page 18 Table 1-1 has similar issue).

Document Name:

Likes: 0

Dislikes: 0

John Seelke - PSEG - 1,3,5,6 - NPCC,RFC

Group Information

Group Name: PSEG

Group Member Name	Entity	Region	Segments
Joseph Smith	Public Service Electric and Gas	RFC	1
Jeffrey Mueller	Public Service Electric and Gas Co.	RFC	3
Tim Kucey	PSEG Fossil LLC	RFC	5
Karla Jara	PSEG Energy Resources & Trade LLC	RFC	6

Voter Information

Voter	Segment
John Seelke	1,3,5,6
Entity	Region(s)
PSEG	NPCC,RFC

Selected Answer: No

Answer Comment: We do not believe this standard is needed.

Document Name:

Likes: 2 PSEG - Public Service Electric and Gas Co., 1, Smith Joseph
PSEG - PSEG Fossil LLC, 5, Kucey Tim

Dislikes: 0

Mike Smith - Manitoba Hydro - 1 -

Selected Answer: No

Answer Comment:

Manitoba Hydro disagrees with the imposed maintenance requirements introduced in PRC-005-6 through the merging of developed maintenance requirements from PRC-005-4.

Manitoba Hydro disagrees with the 6 calendar year maximum maintenance interval proposed in Table 5, relating to sudden pressure relays. Manitoba Hydro has never seen evidence that maintaining sudden pressure relays will in any way prevent instability, cascading outages, or islanding. If such evidence or peer-reviewed publications exist, please share them. Without such evidence, enforcing this maintenance falls outside of NERC's mandate. Moreover, the System Protection and Control Subcommittee (SPCS) errs in believing that it is "more important to base intervals for fault pressure relaying on similar Protection System Components than transformer maintenance intervals." (p 105 of the "PRC-005-4 Supplementary Reference and FAQ – October 2014"). Justification for this perspective is that maintaining sudden pressure relays necessitates transformer outages, which is not the case with most other protection system component maintenance. To avoid unnecessary reliability risks from these transformer outages, sudden pressure relay maintenance should be based on the transformer maintenance intervals, which in Manitoba Hydro's case greatly exceeds six years.

As proposed, PRC-005-6 is mandating a reduction in the availability of equipment (transformers), reducing the reliability of the BES during these maintenance forced outages, without providing any additional security to the BES. The maintenance frequency appears to be arbitrarily aligned with maintenance intervals of other protective systems, which do not require outages or impose notable reliability risks to the BES during such maintenance.

Document Name:

Likes: 0

Dislikes: 0

David Jendras - Ameren - Ameren Services - 3 -

Selected Answer: Yes

Answer Comment:

Document Name:

Likes: 0

Dislikes: 0

Colby Bellville - Duke Energy - 1,3,5,6 - FRCC,SERC,RFC

Group Information

Group Name: Duke Energy

Group Member Name	Entity	Region	Segments
Doug Hils	Duke Energy	RFC	1
Lee Schuster	Duke Energy	FRCC	3
Dale Goodwine	Duke Energy	SERC	5
Greg Cecil	Duke Energy	RFC	6

Voter Information

Voter	Segment
Colby Bellville	1,3,5,6
Entity	Region(s)
Duke Energy	FRCC,SERC,RFC

Selected Answer: Yes

Answer Comment: Duke Energy is supportive of the proposal to combine the Implementation Plans for all of the listed versions of PRC-005. Based on the approaching effective date of PRC-005-3, we encourage that the proposal to combine all Implementation Plans be considered and approved prior to PRC-005-3 effective date.

Document Name:

Likes: 0

Dislikes: 0

Chris Mattson - Tacoma Public Utilities (Tacoma, WA) - 5 -

Selected Answer: Yes

Answer Comment:

Document Name:

Likes: 0

Dislikes: 0

Lee Pedowicz - Northeast Power Coordinating Council - 10 - NPCC

Group Information

Group Name: NPCC--Project 2007-17.4 PRC-005 FERC Order No. 803 Directive - PRC-005-6

Group Member Name	Entity	Region	Segments
Alan Adamson	New York State Reliability Council, LLC	NPCC	10
David Burke	Orange and Rockland Utilities Inc.	NPCC	3
Greg Campoli	New York Independent System Operator	NPCC	2
Gerry Dunbar	Northeast Power Coordinating Council	NPCC	10
Mark Kenny	Northeast Utilities	NPCC	1
Helen Lainis	Independent Electricity System Operator	NPCC	2
Rob Vance	New Brunswick Power Corporation	NPCC	9
Paul Malozewski	Hydro One Networks Inc.	NPCC	1
Bruce Metruck	New York Power Authority	NPCC	6
Lee Pedowicz	Northeast Power Coordinating Council	NPCC	10
David Ramkalawan	Ontario Power Generation, Inc.	NPCC	5
Brian Robinson	Utility Services	NPCC	8
Wayne Sipperly	New York Power Authority	NPCC	5
Edward Bedder	Orange and Rockland Utilities Inc.	NPCC	1
Michael Jones	National Grid	NPCC	1
Brian Shanahan	National Grid	NPCC	1
Glen Smith	Entergy Services, Inc.	NPCC	5
RuiDa Shu	Northeast Power Coordinating Council	NPCC	10
Connie Lowe	Dominion Resources Services, Inc.	NPCC	5

Guy Zito	Northeast Power Coordinating Council	NPCC	10
Silvia Parada Mitchell	NextEra Energy, LLC	NPCC	5
Robert Pellegrini	The United Illuminating Company	NPCC	1
Kathleen Goodman	ISO - New England	NPCC	2
Kelly Dash	Consolidated Edison Co. of New York, Inc.	NPCC	1
Michael Forte	Consolidated Edison Co. of New York, Inc.	NPCC	1
Brian O'Boyle	Consolidated Edison Co. of New York, Inc.	NPCC	8
Peter Yost	Consolidated Edison Co. of New York, Inc.	NPCC	3
Sylvain Clermont	Hydro-Quebec TransEnergie	NPCC	1
Si Truc Phan	Hydro-Quebec TransEnergie	NPCC	1

Voter Information

Voter	Segment
Lee Pedowicz	10
Entity	Region(s)
Northeast Power Coordinating Council	NPCC

Selected Answer: Yes

Answer Comment:

Document Name:

Likes: 0

Dislikes: 0

Jennifer Losacco - NextEra Energy - Florida Power and Light Co. - 1 - FRCC

Selected Answer: Yes

Answer Comment:

Document Name:

Likes: 0

Dislikes: 0

Charles Yeung - Southwest Power Pool, Inc. (RTO) - 2 -

Group Information

Group Name: IRC Standards Review Committee

Group Member Name	Entity	Region	Segments
Charles Yeung	SPP	SPP	2
Ben Li	IESO	NPCC	2
Greg Campoli	NYISO	NPCC	2
Mark Holman	PJM	RFC	2
Matt Goldberg	ISONE	NPCC	2
Lori Spence	MISO	MRO	2
Christina Bigelow	ERCOT	TRE	2
Ali Miremadi	CAISO	WECC	2

Voter Information

Voter	Segment
Charles Yeung	2
Entity	Region(s)
Southwest Power Pool, Inc. (RTO)	

Selected Answer:

Answer Comment:

Document Name:

Likes: 0

Dislikes: 0

Jason Smith - Southwest Power Pool, Inc. (RTO) - 2 - SPP

Group Information

Group Name: SPP Standards Review Group

Group Member Name	Entity	Region	Segments
Shannon Mickens	Southwest Power Pool	SPP	2
Jason Smith	Southwest Power Pool	SPP	2
Karl Diekevers	Nebraska Public Power District	MRO	1,3,5
Allan George	Sunflower Electric Power Corporation	SPP	1
Robert Gray	Board of Public Utilities Kansas City, Kansas	SPP	3
Robert Hirschak	CLECO Corporation	SPP	1,3,5,6
Stephanie Johnson	Westar Energy, Inc.	SPP	1,3,5,6
James Nail	City of Independence, Missouri	SPP	3,5
Scott Williams	City Utilities of Springfield	SPP	1,4

Voter Information

Voter **Segment**

Jason Smith 2

Entity **Region(s)**

Southwest Power Pool, Inc. (RTO) SPP

Selected Answer: Yes

Answer Comment:

The proposed implementation plan and request by NERC to align the implementations seem to address prior concerns with the staggered and confusing implementation dates. Thank you for the effort.

Document Name:

Likes: 0

Dislikes: 0

Ben Engelby - ACES Power Marketing - 6 -

Group Information

Group Name: ACES Standards Collaborators - PRC-005 Project

Group Member Name	Entity	Region	Segments
Amber Skillern	East Kentucky Power Cooperative	SERC	1,3
Shari Heino	Brazos Electric Power Cooperative, Inc.	TRE	1,5
Bob Solomon	Hoosier Energy Rural Electric Cooperative, Inc.	RFC	1
Mike Brytowski	Great River Energy	MRO	1,3,5,6
Ellen Watkins	Sunflower Electric Power Corporation	SPP	1
Ryan Strom	Buckeye Power, Inc.	RFC	4
Ginger Mercier	Prairie Power, Inc.	SERC	1,3
Lucia Beal	Southern Maryland Electric Cooperative	RFC	3

Voter Information

Voter Ben Engelby **Segment** 6

Entity ACES Power Marketing **Region(s)**

Selected Answer: Yes

Answer Comment:

We believe that unless there is an urgent reliability gap, revisions to PRC-005 should be limited to no more than once per year. Frequent modifications to these requirements can have detrimental effects on electric system reliability due to rushed standards development and the possibility of inadequately reviewed relay test plans.

While we agree with the approach in the current implementation plan, we question the process of having multiple versions that have resulted in the conundrum that we face today. Each effective version of PRC-005 should supersede all previous versions and include all current requirements for

clarity. We understand and appreciate that there are varied implementation dates for different requirements, but maintaining multiple versions is cumbersome, burdensome, and creates risk that a requirement is missed. We believe confusion would be alleviated if the NERC Standards Department had a policy of requiring each standard revision have a whole number for the next applicable version. For example, if PRC-005-2 is to be superseded, then PRC-005-2 would be retired and PRC-005-“3” would take precedence. We strongly urge NERC to discontinue the practice of creating sub-sets with standard versions, such as “PRC-005-2(i)”.

Document Name:

Likes: 0

Dislikes: 0

Oshani Pathirane - Oshani Pathirane On Behalf of: Paul Malozewski, Hydro One Networks, Inc., 1, 3
Payam Farahbakhsh, Hydro One Networks, Inc., 1, 3

Selected Answer:

Answer Comment:

Document Name:

Likes: 0

Dislikes: 0

Consideration of Comments

Project Name: 2007-17.4 PRC-005 FERC Order No. 803 Directive | PRC-005-6

Comment Period Start Date: 7/30/2015

Comment Period End Date: 9/16/2015

Associated Ballot: 2007-17.4 PRC-005 FERC Order No. 803 Directive PRC-005-6 IN 1 ST

There were 30 responses, including comments from approximately 108 different people from approximately 79 different companies representing 9 of the 10 Industry Segments as shown on the following pages.

All comments submitted can be reviewed in their original format on the project page.

If you feel that your comment has been overlooked, please let us know immediately. Our goal is to give every comment serious consideration in this process. If you feel there has been an error or omission, you can contact the Director of Standards, Howard Gugel (via email) or at (404) 446-9693.

Summary Consideration of Comments:

The PSMT SDT reviewed and responded to each comment received during the posting for Initial Ballot. The SDT made some clarifying or editorial changes to the standard and associated documents but no substantive revisions were made. Several commenters suggested editorial changes to the standard for consistency. These edits include:

- Revised the bulleting in Table 4-1 to accurately reflect the SDT's intent.
- Revised the headers in Tables 4-2(a), 4-2(b) and 4-3 to correct "sudden pressure relaying" to "automatic reclosing".
- Revised the use of "ac" and "dc" to be consistent throughout the standard and Supplementary Reference and FAQ document per the NERC Style Guide.
- Revised the Version History table to be more detailed regarding the revisions.
- Revised the third and fourth bullets in the definition of Automatic Reclosing for consistency by adding "or function(s)" as in the second bullet. This revision was also made to the Consideration of Directives document.

Several commenters suggested editorial changes to the Supplementary Reference and FQA document. These edits include:

- Added a “revision history” to the introductory paragraphs referencing the revisions made since development of the document for PRC-005-2.
- Revised the use of “ac” and “dc” to be consistent throughout the standard and Supplementary Reference and FAQ document per the NERC Style Guide.
- Corrected the reference from R3 to R5 in flowchart on page 21.
- Corrected the formatting of an FAQ regarding inclusion of IEEE function numbers to clearly indicate that the list is part of the question (Section 15.8.1).
- Clarified the FAQ to better describe the synchronism check function (Section 2.4.1).
- Clarified the definition of Automatic Reclosing to ensure it is consistent with IEEE definition 100 and added a Q/A in the FAQ document. (Section 2.4.1)

Commenters overwhelmingly agreed with the effort to streamline and consolidate the Implementation Plan. A few additional comments were submitted regarding content that are outside of the scope of the SAR for this project including the necessity for the standard and previously approved versions of the standard.

Questions

1. The PSMTSDT has proposed revising the definition of “Automatic Reclosing” and “Component Type” to address the FERC directive in Order 803. Do you agree that the proposed revised definitions? If not, please provide specific comments regarding the revision and any suggestions for alternatives to address the directive.
2. The PSMTSDT has added Table 4-3 to address maintenance activities and intervals for voltage sensing devices associated with supervisory relays. Do you agree with the proposed table? If not, please provide specific comments regarding the table and any suggestions for alternative language.
3. The PSMTSDT has made revisions to the Supplementary Reference and FAQ Document. Do you agree with the proposed revisions? If not, please provide specific comments regarding the revisions and any suggestions for alternative language.
4. The PSMTSDT has proposed combining the Implementation Plans for previous versions of PRC-005 (including PRC-005-3, PRC-005-3i, PRC-005-3ii, PRC-005-4 and PRC-005-5). Do you agree with the proposed Implementation Plan? If not, please provide specific comments regarding the Implementation Plan and any suggestions for alternative language.

The Industry Segments are:

- 1 — Transmission Owners
- 2 — RTOs, ISOs
- 3 — Load-serving Entities
- 4 — Transmission-dependent Utilities
- 5 — Electric Generators
- 6 — Electricity Brokers, Aggregators, and Marketers
- 7 — Large Electricity End Users
- 8 — Small Electricity End Users
- 9 — Federal, State, Provincial Regulatory or other Government Entities
- 10 — Regional Reliability Organizations, Regional Entities

1. The PSMTSDT has proposed revising the definition of “Automatic Reclosing” and “Component Type” to address the FERC directive in Order 803. Do you agree that the proposed revised definitions? If not, please provide specific comments regarding the revision and any suggestions for alternatives to address the directive.

John Fontenot - Bryan Texas Utilities - 1 -	
Selected Answer:	Yes
Meghan Ferguson - International Transmission Company Holdings Corporation On Behalf of: Michael Moltane, International Transmission Company Holdings Corporation, 1	
Selected Answer:	Yes
Barbara Kedrowski - WEC Energy Group, Inc. - 3,4,5 - RFC	
Selected Answer:	No
Answer Comment:	The SDT needs to add to the definition of automatic reclosing to differentiate it from manual reclosing. This could be a possible area of confusion with compliance auditors.
Response:	The SDT believes that the term Automatic Reclosing is sufficiently differentiated to not include manual reclosing.
Andrew Pusztai - American Transmission Company, LLC - 1 -	

Selected Answer:	Yes		
Thomas Foltz - AEP - 5 -			
Selected Answer:	Yes		
Jamison Dye - Bonneville Power Administration - 1,3,5,6 - WECC			
Selected Answer:	Yes		
Leonard Kula - Independent Electricity System Operator - 2 -			
Selected Answer:	Yes		
Emily Rousseau - MRO - 1,2,3,4,5,6 - MRO			
Group Name:	MRO-NERC Standards Review Forum (NSRF)		
Group Member Name	Entity	Region	Segments
Joe Depoorter	Madison Gas & Electric	MRO	3,4,5,6
Amy Casucelli	Xcel Energy	MRO	1,3,5,6
Chuck Lawrence	American Transmission Company	MRO	1
Chuck Wicklund	Otter Tail Power Company	MRO	1,3,

			5
Theresa Allard	Minnkota Power Cooperative, Inc	MRO	1,3,5,6
Dave Rudolph	Basin Electric Power Cooperative	MRO	1,3,5,6
Kayleigh Wilkerson	Lincoln Electric System	MRO	1,3,5,6
Jodi Jenson	Western Area Power Administration	MRO	1,6
Larry Heckert	Alliant Energy	MRO	4
Mahmood Safi	Omaha Public Utility District	MRO	1,3,5,6
Shannon Weaver	Midwest ISO Inc.	MRO	2
Mike Brytowski	Great River Energy	MRO	1,3,5,6
Brad Perrett	Minnesota Power	MRO	1,5
Scott Nickels	Rochester Public Utilities	MRO	4
Terry Harbour	MidAmerican Energy Company	MRO	1,3,5,6
Tom Breene	Wisconsin Public Service Corporation	MRO	3,4,5,6
Tony Eddleman	Nebraska Public Power District	MRO	1,3,5

Selected Answer: Yes

Gul Khan - Gul Khan On Behalf of: Rod Kinard, Oncor Electric Delivery, 1

Selected Answer: Yes

Amy Casuscelli - Xcel Energy, Inc. - 1,3,5,6 - MRO,WECC,SPP

Selected Answer: Yes

Adam Padgett - TECO - Tampa Electric Co. - 1,3,4,5 - FRCC

Selected Answer: Yes

Randi Heise - Dominion - Dominion Resources, Inc. - 5 -

Group Name: Dominion - RCS

Group Member Name	Entity	Region	Segments
Larry Nash	Dominion Virginia Power	SERC	1
Louis Slade	Dominion Resources, Inc.	SERC	6
Connie Lowe	Dominion Resources, Inc.	RFC	3
Randi Heise	Dominion Resources, Inc,	NPCC	5

Selected Answer: Yes

Answer Comment: Dominion suggest that Version history 6 should be updated to be inclusive of the directive and read as; "Revised to add supervisory relays, the voltage sensing devices, and the associated control circuitry to Automatic Reclosing in accordance with the directives in FERC Order 803.

Response: The SDT agrees and has made the suggested editorial revision.

John Coggins - Salt River Project - 3 -	
Selected Answer:	Yes
Molly Devine - IDACORP - Idaho Power Company - 1 -	
Selected Answer:	Yes
Rachel Coyne - Texas Reliability Entity, Inc. - 10 -	
Selected Answer:	Yes
Answer Comment:	The definition of Automatic Reclosing is not definitive on the functional aspect (Sudden Pressure Relaying provides functional aspect) and just delineates what Components are included. Is that the standard drafting team’s intent? Does the use of the term “Automatic Reclosing” in Table 4-1 Maintenance Activities make sense without a functional aspect being defined?
Response: The SDT believes that the standard specific definition of Automatic Reclosing is sufficiently definitive as well as its use in Table 4-1.	
John Seelke - PSEG - 1,3,5,6 - NPCC,RFC	
Group Name:	PSEG

Group Member Name	Entity	Region	Segments
Joseph Smith	Public Service Electric and Gas	RFC	1
Jeffrey Mueller	Public Service Electric and Gas Co.	RFC	3
Tim Kucey	PSEG Fossil LLC	RFC	5
Karla Jara	PSEG Energy Resources & Trade LLC	RFC	6

Selected Answer: No

Answer Comment: We do not believe this standard is needed.

Response: This standard is developed explicitly to address directives from FERC Order 803. NERC is statutorily obligated to address the directives, either directly or via equally effective actions, and has determined that there are no equally effective alternatives.

Likes: 2 PSEG - Public Service Electric and Gas Co., 1, Smith Joseph
PSEG - PSEG Fossil LLC, 5, Kucey Tim

Dislikes: 0

Mike Smith - Manitoba Hydro - 1 -

Selected Answer: Yes

David Jendras - Ameren - Ameren Services - 3 -

Selected Answer: Yes

Colby Bellville - Duke Energy - 1,3,5,6 - FRCC,SERC,RFC

Group Name: Duke Energy

Group Member Name	Entity	Region	Segments
Doug Hils	Duke Energy	RFC	1
Lee Schuster	Duke Energy	FRCC	3
Dale Goodwine	Duke Energy	SERC	5
Greg Cecil	Duke Energy	RFC	6

Selected Answer: No

Answer Comment: Duke Energy requests further clarification from the drafting team on the proposed definition of Automatic Reclosing. Is it the drafting team's intent that the definition should incorporate all closings that happen automatically, or just Automatic Reclosing relays? There are some scenarios where there is an automatic closing, but no relay is present. There are also some instances where a Supervisory relay is not supervising a reclosing relay, and just providing a close command itself. Would these Supervisory relays that do not supervise an Automatic Reclosing relay be in scope? We ask the drafting team to clarify the intent of the definition, chiefly whether all automatic closing, even in the event that a relay is not present, falls under the scope of this standard, as well as our concern

regarding the scope of Supervisory relays.

Response: The SDT notes that Automatic Reclosing includes automatic reclosing and not automatic closing. We have added part of IEEE Standard 100 definition to the Supplementary Reference and FAQ document as follows to add clarity: “Automatic reclosing equipment - Automatic equipment that provides for reclosing a switching device as desired after it has opened automatically under abnormal conditions.” See Section 2.4.1.

Chris Mattson - Tacoma Public Utilities (Tacoma, WA) - 5 -

Selected Answer: No

Answer Comment: Tacoma Power generally agrees with the revised definition of “Automatic Reclosing”; however, Tacoma Power recommends consistently using “supervisory relay(s)” or “supervisory relay(s) or function(s)” among the bulleted Component Types.

Response: The SDT agrees and has made the editorial revision.

Lee Pedowicz - Northeast Power Coordinating Council - 10 - NPCC

Group Name: NPCC--Project 2007-17.4 PRC-005 FERC Order No. 803 Directive - PRC-005-6

Group Member Name	Entity	Region	Segments
Alan Adamson	New York State Reliability Council, LLC	NPCC	10

David Burke	Orange and Rockland Utilities Inc.	NPCC	3
Greg Campoli	New York Independent System Operator	NPCC	2
Gerry Dunbar	Northeast Power Coordinating Council	NPCC	10
Mark Kenny	Northeast Utilities	NPCC	1
Helen Lainis	Independent Electricity System Operator	NPCC	2
Rob Vance	New Brunswick Power Corporation	NPCC	9
Paul Malozewski	Hydro One Networks Inc.	NPCC	1
Bruce Metruck	New York Power Authority	NPCC	6
Lee Pedowicz	Northeast Power Coordinating Council	NPCC	10
David Ramkalawan	Ontario Power Generation, Inc.	NPCC	5
Brian Robinson	Utility Services	NPCC	8
Wayne Sipperly	New York Power Authority	NPCC	5
Edward Bedder	Orange and Rockland Utilities Inc.	NPCC	1
Michael Jones	National Grid	NPCC	1
Brian Shanahan	National Grid	NPCC	1
Glen Smith	Entergy Services, Inc.	NPCC	5
RuiDa Shu	Northeast Power Coordinating Council	NPCC	10
Connie Lowe	Dominion Resources Services, Inc.	NPCC	5
Guy Zito	Northeast Power Coordinating Council	NPCC	10
Silvia Parada Mitchell	NextEra Energy, LLC	NPCC	5
Robert Pellegrini	The United Illuminating	NPCC	1

	Company		
Kathleen Goodman	ISO - New England	NPCC	2
Kelly Dash	Consolidated Edison Co. of New York, Inc.	NPCC	1
Michael Forte	Consolidated Edison Co. of New York, Inc.	NPCC	1
Brian O'Boyle	Consolidated Edison Co. of New York, Inc.	NPCC	8
Peter Yost	Consolidated Edison Co. of New York, Inc.	NPCC	3
Sylvain Clermont	Hydro-Quebec TransEnergie	NPCC	1
Si Truc Phan	Hydro-Quebec TransEnergie	NPCC	1

Selected Answer: Yes

Jennifer Losacco - NextEra Energy - Florida Power and Light Co. - 1 - FRCC

Selected Answer: Yes

Charles Yeung - Southwest Power Pool, Inc. (RTO) - 2 -

Group Name: IRC Standards Review Committee

Group Member Name	Entity	Region	Segments
Charles Yeung	SPP	SPP	2
Ben Li	IESO	NPCC	2
Greg Campoli	NYISO	NPCC	2

Mark Holman	PJM	RFC	2
Matt Goldberg	ISONE	NPCC	2
Lori Spence	MISO	MRO	2
Christina Bigelow	ERCOT	TRE	2
Ali Miremadi	CAISO	WEC C	2

Selected Answer: Yes

Answer Comment: Thank you for the clarification which addresses the SRC's comments on the SAR.

Response: Thank you for your support.

Jason Smith - Southwest Power Pool, Inc. (RTO) - 2 - SPP

Group Name: SPP Standards Review Group

Group Member Name	Entity	Region	Segments
Shannon Mickens	Southwest Power Pool	SPP	2
Jason Smith	Southwest Power Pool	SPP	2
Karl Diekevers	Nebraska Public Power District	MRO	1,3,5
Allan George	Sunflower Electric Power Corporation	SPP	1
Robert Gray	Board of Public Utilities Kansas City, Kansas	SPP	3

Robert Hirschak	CLECO Corporation	SPP	1,3, 5,6
Stephanie Johnson	Westar Energy, Inc.	SPP	1,3, 5,6
James Nail	City of Independence, Missouri	SPP	3,5
Scott Williams	City Utilities of Springfield	SPP	1,4

Selected Answer: Yes

Ben Engelby - ACES Power Marketing - 6 -

Group Name: ACES Standards Collaborators - PRC-005 Project

Group Member Name	Entity	Region	Segments
Amber Skillern	East Kentucky Power Cooperative	SERC	1,3
Shari Heino	Brazos Electric Power Cooperative, Inc.	TRE	1,5
Bob Solomon	Hoosier Energy Rural Electric Cooperative, Inc.	RFC	1
Mike Brytowski	Great River Energy	MRO	1,3, 5,6
Ellen Watkins	Sunflower Electric Power Corporation	SPP	1
Ryan Strom	Buckeye Power, Inc.	RFC	4
Ginger Mercier	Prairie Power, Inc.	SERC	1,3
Lucia Beal	Southern Maryland Electric Cooperative	RFC	3

Selected Answer: Yes

Answer Comment: The definition change is consistent with the FERC directive in Order 803.

Response: Thank you for your support.

**Oshani Pathirane - Oshani Pathirane On Behalf of: Paul Malozewski, Hydro One Networks, Inc., 1, 3
Payam Farahbakhsh, Hydro One Networks, Inc., 1, 3**

Selected Answer: Yes

Answer Comment: With respect to requirements 4.2.7.1 and 4.2.7.2, automatic reclosing relays addressed are subject to an exemption if the owner of the equipment could demonstrate that a close-in three-phase fault present for twice the normal clearing time (capturing a minimum trip-close-trip time delay) does not result in a total loss of gross generation in the Interconnection exceeding the gross capacity of the largest relevant BES generating unit where the Automatic Reclosing is applied. However, Hydro One Networks Inc. would like to suggest that the SDT consider indicating the timelines for demonstrating the above applicability. For example, additional detail on what would trigger a system review, or intervals in which the system review should be performed, could be explicitly stated within the body of the standard.

Response: Your suggestion relates to previously-approved content, and is outside the scope of the SAR for this revision.



2. The PSMTSDT has added Table 4-3 to address maintenance activities and intervals for voltage sensing devices associated with supervisory relays. Do you agree with the proposed table? If not, please provide specific comments regarding the table and any suggestions for alternative language.

John Fontenot - Bryan Texas Utilities - 1 -

Selected Answer: Yes

Meghan Ferguson - International Transmission Company Holdings Corporation On Behalf of: Michael Moltane, International Transmission Company Holdings Corporation, 1

Selected Answer: No

Answer Comment: The note on Table 4-3 needs to be updated with the correct information and table reference.

Currently, the Note on Table 4-3 reads: *"Note: In cases where **Components of Sudden Pressure Relaying** are common to Components listed in **Table 1-5**, the Components only need to be tested once during a distinct maintenance interval."*

The Note on Table 4-3 should be re-worded as: *"Note: In cases where **Automatic Reclosing Components** are common to Components listed in **Table 1-3**, the Components only need to be tested once during a distinct maintenance interval."*

Response: The SDT agrees and has made the editorial change.

<p>Andrew Pusztai - American Transmission Company, LLC - 1 -</p> <p>Selected Answer: Yes</p>											
<p>Thomas Foltz - AEP - 5 -</p> <p>Selected Answer: Yes</p>											
<p>Jamison Dye - Bonneville Power Administration - 1,3,5,6 - WECC</p> <p>Selected Answer: Yes</p>											
<p>Leonard Kula - Independent Electricity System Operator - 2 -</p> <p>Selected Answer: Yes</p>											
<p>Emily Rousseau - MRO - 1,2,3,4,5,6 - MRO</p> <p>Group Name: MRO-NERC Standards Review Forum (NSRF)</p> <table border="1"> <thead> <tr> <th>Group Member Name</th> <th>Entity</th> <th>Region</th> <th>Segments</th> </tr> </thead> <tbody> <tr> <td>Joe Depoorter</td> <td>Madison Gas & Electric</td> <td>MRO</td> <td>3,4,5,6</td> </tr> </tbody> </table>				Group Member Name	Entity	Region	Segments	Joe Depoorter	Madison Gas & Electric	MRO	3,4,5,6
Group Member Name	Entity	Region	Segments								
Joe Depoorter	Madison Gas & Electric	MRO	3,4,5,6								

Amy Casucelli	Xcel Energy	MRO	1,3,5,6
Chuck Lawrence	American Transmission Company	MRO	1
Chuck Wicklund	Otter Tail Power Company	MRO	1,3,5
Theresa Allard	Minnkota Power Cooperative, Inc	MRO	1,3,5,6
Dave Rudolph	Basin Electric Power Cooperative	MRO	1,3,5,6
Kayleigh Wilkerson	Lincoln Electric System	MRO	1,3,5,6
Jodi Jenson	Western Area Power Administration	MRO	1,6
Larry Heckert	Alliant Energy	MRO	4
Mahmood Safi	Omaha Public Utility District	MRO	1,3,5,6
Shannon Weaver	Midwest ISO Inc.	MRO	2
Mike Brytowski	Great River Energy	MRO	1,3,5,6
Brad Perrett	Minnesota Power	MRO	1,5
Scott Nickels	Rochester Public Utilities	MRO	4
Terry Harbour	MidAmerican Energy Company	MRO	1,3,5,6
Tom Breene	Wisconsin Public Service Corporation	MRO	3,4,5,6
Tony Eddleman	Nebraska Public Power District	MRO	1,3,5

Selected Answer: Yes

<p>Gul Khan - Gul Khan On Behalf of: Rod Kinard, Oncor Electric Delivery, 1</p> <p>Selected Answer: Yes</p>																					
<p>Amy Casuscelli - Xcel Energy, Inc. - 1,3,5,6 - MRO,WECC,SPP</p> <p>Selected Answer: Yes</p>																					
<p>Adam Padgett - TECO - Tampa Electric Co. - 1,3,4,5 - FRCC</p> <p>Selected Answer: Yes</p>																					
<p>Randi Heise - Dominion - Dominion Resources, Inc. - 5 -</p> <p>Group Name: Dominion - RCS</p> <table border="1"> <thead> <tr> <th>Group Member Name</th> <th>Entity</th> <th>Region</th> <th>Segments</th> </tr> </thead> <tbody> <tr> <td>Larry Nash</td> <td>Dominion Virginia Power</td> <td>SERC</td> <td>1</td> </tr> <tr> <td>Louis Slade</td> <td>Dominion Resources, Inc.</td> <td>SERC</td> <td>6</td> </tr> <tr> <td>Connie Lowe</td> <td>Dominion Resources, Inc.</td> <td>RFC</td> <td>3</td> </tr> <tr> <td>Randi Heise</td> <td>Dominion Resources, Inc,</td> <td>NPCC</td> <td>5</td> </tr> </tbody> </table> <p>Selected Answer: Yes</p> <p>Answer Comment: Dominion also suggests Table 1-1 (redline version page 18 of</p>		Group Member Name	Entity	Region	Segments	Larry Nash	Dominion Virginia Power	SERC	1	Louis Slade	Dominion Resources, Inc.	SERC	6	Connie Lowe	Dominion Resources, Inc.	RFC	3	Randi Heise	Dominion Resources, Inc,	NPCC	5
Group Member Name	Entity	Region	Segments																		
Larry Nash	Dominion Virginia Power	SERC	1																		
Louis Slade	Dominion Resources, Inc.	SERC	6																		
Connie Lowe	Dominion Resources, Inc.	RFC	3																		
Randi Heise	Dominion Resources, Inc,	NPCC	5																		

	<p>41), 1st bullet be revised from “Ac measurements” to read as AC measurements..</p> <p>Response: We have revised the use of “ac” and “dc” to be consistent throughout the standard and Supplementary Reference and FAQ document per the NERC Style Guide.</p>
<p>John Coggins - Salt River Project - 3 -</p> <p>Selected Answer:</p>	<p>Yes</p>
<p>Molly Devine - IDACORP - Idaho Power Company - 1 -</p> <p>Selected Answer:</p>	<p>Yes</p>
<p>Rachel Coyne - Texas Reliability Entity, Inc. - 10 -</p> <p>Selected Answer:</p> <p>Answer Comment:</p>	<p>No</p> <p>1. Texas RE inquires as to why the standard drafting team choose 12 years for this Component Type. In general, in most, not all, of the previous Tables provided for maintenance activities of any unmonitored relay had a 6 Calendar Year Minimum Maintenance Interval.</p> <p>Texas RE noticed Maintenance Activities of Table 4-1 are not consistent (e.g.- Row 1 states “Verify that settings are as specified” but Row 2 states “Verify: Settings are as specified” (in bullets) but the format is backwards for the</p>

“Operation of the relay inputs...” statement in both rows.

2. Additional clarity may be needed between the Table 4-1 additions and Table 4-3. In Table 4-1 there is a Component Attribute for supervisory relays that essentially states a 12 Calendar Year Maximum Maintenance Interval for supervisory relays that have “AC measurements are continuously verified by comparison to an independent AC measurement source, with alarming for excessive error (See Table 2).” In Table 4-3 “Voltage sensing devices that are connected to microprocessor supervisory relays with AC measurements that are continuously verified by comparison of sensing input value, as measured by the microprocessor relay, to an independent AC measurement source, with alarming for unacceptable error or failure. (See Table 2)” has no periodic maintenance specified. Texas RE is concerned it appears an entity is required to do the “Maintenance Activity” described in Table 4-1 (“Verify acceptable measurement of power system input values.”) within 12 Calendar Years on the relays but is not required to do any Maintenance Activity on the voltage sensing devices.

Response:

- 1. The SDT notes that Table 4-3 is similar to the unmonitored maintenance activities in Table 1-3. This is why the 12-year maintenance interval was chosen. We have also corrected the bullet format in Table 4-1.**
- 2. The SDT notes that Table 4-3 does not prescribe relay maintenance of voltage sensing devices and is consistent with Table 1-3.**

John Seelke - PSEG - 1,3,5,6 - NPCC,RFC

Group Name: PSEG

Group Member Name	Entity	Region	Segments
Joseph Smith	Public Service Electric and Gas	RFC	1
Jeffrey Mueller	Public Service Electric and Gas Co.	RFC	3
Tim Kucey	PSEG Fossil LLC	RFC	5
Karla Jara	PSEG Energy Resources & Trade LLC	RFC	6

Selected Answer: No

Answer Comment: We do not believe this standard is needed.

Response: This standard is developed explicitly to address directives from FERC Order 803. NERC is statutorily obligated to address the directives, either directly or via equally effective actions, and has determined that there are no equally effective alternatives.

Likes: 2 PSEG - Public Service Electric and Gas Co., 1, Smith Joseph
PSEG - PSEG Fossil LLC, 5, Kucey Tim

Dislikes: 0

Mike Smith - Manitoba Hydro - 1 -

Selected Answer:	Yes																				
David Jendras - Ameren - Ameren Services - 3 -																					
Selected Answer:	Yes																				
Colby Bellville - Duke Energy - 1,3,5,6 - FRCC,SERC,RFC																					
Group Name:	Duke Energy																				
<table border="1"> <thead> <tr> <th>Group Member Name</th> <th>Entity</th> <th>Region</th> <th>Segments</th> </tr> </thead> <tbody> <tr> <td>Doug Hils</td> <td>Duke Energy</td> <td>RFC</td> <td>1</td> </tr> <tr> <td>Lee Schuster</td> <td>Duke Energy</td> <td>FRCC</td> <td>3</td> </tr> <tr> <td>Dale Goodwine</td> <td>Duke Energy</td> <td>SERC</td> <td>5</td> </tr> <tr> <td>Greg Cecil</td> <td>Duke Energy</td> <td>RFC</td> <td>6</td> </tr> </tbody> </table>		Group Member Name	Entity	Region	Segments	Doug Hils	Duke Energy	RFC	1	Lee Schuster	Duke Energy	FRCC	3	Dale Goodwine	Duke Energy	SERC	5	Greg Cecil	Duke Energy	RFC	6
Group Member Name	Entity	Region	Segments																		
Doug Hils	Duke Energy	RFC	1																		
Lee Schuster	Duke Energy	FRCC	3																		
Dale Goodwine	Duke Energy	SERC	5																		
Greg Cecil	Duke Energy	RFC	6																		
Selected Answer:	Yes																				
Answer Comment:	Duke Energy is unsure of the necessity of inserting the note: "Note: In cases where Components of Sudden Pressure Relaying are common to Components listed in Table 1-5, the Components only need to be tested once during a distinct maintenance interval" to Table 4-3. It doesn't appear that the note is applicable to this Table. We recommend that the drafting team consider only including the Note on tables where it is best applicable.																				
Response: The SDT has corrected the erroneous reference to Table 1-5. It should have been Table 1-3.																					

Chris Mattson - Tacoma Public Utilities (Tacoma, WA) - 5 -

Selected Answer: Yes

Answer Comment: In Tables 4-2(a), 4-2(b), and 4-3, "Sudden Pressure Relaying" should be changed to "Automatic Reclosing."

Response: Thank you. The SDT agrees that the header blocks are incorrect and have made the associated editorial changes.

Lee Pedowicz - Northeast Power Coordinating Council - 10 - NPCC

Group Name: NPCC--Project 2007-17.4 PRC-005 FERC Order No. 803 Directive - PRC-005-6

Group Member Name	Entity	Region	Segments
Alan Adamson	New York State Reliability Council, LLC	NPCC	10
David Burke	Orange and Rockland Utilities Inc.	NPCC	3
Greg Campoli	New York Independent System Operator	NPCC	2
Gerry Dunbar	Northeast Power Coordinating Council	NPCC	10

Mark Kenny	Northeast Utilities	NPCC	1
Helen Lainis	Independent Electricity System Operator	NPCC	2
Rob Vance	New Brunswick Power Corporation	NPCC	9
Paul Malozewski	Hydro One Networks Inc.	NPCC	1
Bruce Metruck	New York Power Authority	NPCC	6
Lee Pedowicz	Northeast Power Coordinating Council	NPCC	10
David Ramkalawan	Ontario Power Generation, Inc.	NPCC	5
Brian Robinson	Utility Services	NPCC	8
Wayne Sipperly	New York Power Authority	NPCC	5
Edward Bedder	Orange and Rockland Utilities Inc.	NPCC	1
Michael Jones	National Grid	NPCC	1
Brian Shanahan	National Grid	NPCC	1
Glen Smith	Entergy Services, Inc.	NPCC	5
RuiDa Shu	Northeast Power Coordinating Council	NPCC	10
Connie Lowe	Dominion Resources Services, Inc.	NPCC	5
Guy Zito	Northeast Power Coordinating Council	NPCC	10
Silvia Parada Mitchell	NextEra Energy, LLC	NPCC	5
Robert Pellegrini	The United Illuminating Company	NPCC	1
Kathleen Goodman	ISO - New England	NPCC	2
Kelly Dash	Consolidated Edison Co. of New York, Inc.	NPCC	1
Michael Forte	Consolidated Edison Co. of New York, Inc.	NPCC	1

Brian O'Boyle	Consolidated Edison Co. of New York, Inc.	NPCC	8
Peter Yost	Consolidated Edison Co. of New York, Inc.	NPCC	3
Sylvain Clermont	Hydro-Quebec TransEnergie	NPCC	1
Si Truc Phan	Hydro-Quebec TransEnergie	NPCC	1

Selected Answer: Yes

Jennifer Losacco - NextEra Energy - Florida Power and Light Co. - 1 - FRCC

Selected Answer: Yes

Jason Smith - Southwest Power Pool, Inc. (RTO) - 2 - SPP

Group Name: SPP Standards Review Group

Group Member Name	Entity	Region	Segments
Shannon Mickens	Southwest Power Pool	SPP	2
Jason Smith	Southwest Power Pool	SPP	2
Karl Diekevers	Nebraska Public Power District	MRO	1,3,5
Allan George	Sunflower Electric Power Corporation	SPP	1
Robert Gray	Board of Public Utilities Kansas City, Kansas	SPP	3
Robert Hirchak	CLECO Corporation	SPP	1,3,

			5,6
Stephanie Johnson	Westar Energy, Inc.	SPP	1,3,5,6
James Nail	City of Independence, Missouri	SPP	3,5
Scott Williams	City Utilities of Springfield	SPP	1,4

Selected Answer: Yes

Ben Engelby - ACES Power Marketing - 6 -

Group Name: ACES Standards Collaborators - PRC-005 Project

Group Member Name	Entity	Region	Segments
Amber Skillern	East Kentucky Power Cooperative	SERC	1,3
Shari Heino	Brazos Electric Power Cooperative, Inc.	TRE	1,5
Bob Solomon	Hoosier Energy Rural Electric Cooperative, Inc.	RFC	1
Mike Brytowski	Great River Energy	MRO	1,3,5,6
Ellen Watkins	Sunflower Electric Power Corporation	SPP	1
Ryan Strom	Buckeye Power, Inc.	RFC	4
Ginger Mercier	Prairie Power, Inc.	SERC	1,3
Lucia Beal	Southern Maryland Electric Cooperative	RFC	3

Selected Answer:

Yes

Answer Comment:

1. We identified a minor grammatical error in Table 1-1.
 1. There is inconsistent capitalization of the acronym "AC" in the first bullet, which lists both "Ac" and "AC".
 2. We ask the drafting team to clarify in Table 4-1 the phrase "with preceding row attributes," as the format of the table is unclear whether the reference is to all of the monitored microprocessor reclosing relays and supervisory relays, including Table 2, or just the supervisory relays with waveform sampling three or more times per power cycle. The format of each table carrying over the header from the previous page makes the phrase "with preceding row attributes" unclear.
 3. We appreciate the drafting team providing clarity in the note of Table 4-3 for cases where Components of Sudden Pressure Relaying are common to Components listed in Table 1-5, the Components only need to be tested once during a distinct maintenance interval.

Response:

1. **We have revised the use of "ac" and "dc" to be consistent throughout the standard and Supplementary Reference and FAQ document per the NERC Style Guide.**
2. **The SDT believes that "the preceding row" is sufficiently clear to indicate one individual preceding row in the table. Otherwise, the SDT would have stated, "all preceding rows".**
3. **Thank you for your support.**

Oshani Pathirane - Oshani Pathirane On Behalf of: Paul Malozewski, Hydro One Networks, Inc., 1, 3
Payam Farahbakhsh, Hydro One Networks, Inc., 1, 3

Selected Answer: No

Answer Comment: Hydro One Networks Inc. would like to suggest that, the wording of the title bar's note be changed to read, "In cases where **Automatic Reclosing Components** are common to Components listed in **Tables 1-3 and 1-5**, the Components only need to be tested once during a distinct maintenance interval."

Hydro One Networks Inc. would also like to suggest that Tables 4-2(a) and 4-2(b) title bars' notes also be revised to read, "Automatic Reclosing Components", instead of "Sudden Pressure Relaying"

Response: Thank you. The SDT agrees that the header blocks are incorrect and we have made the associated editorial changes.

3. The PSMTSDT has made revisions to the Supplementary Reference and FAQ Document. Do you agree with the proposed revisions? If not, please provide specific comments regarding the revisions and any suggestions for alternative language.

John Fontenot - Bryan Texas Utilities - 1 -	
Selected Answer:	Yes
Meghan Ferguson - International Transmission Company Holdings Corporation On Behalf of: Michael Moltane, International Transmission Company Holdings Corporation, 1	
Selected Answer:	Yes
Andrew Puzstai - American Transmission Company, LLC - 1 -	
Selected Answer:	Yes
Answer Comment:	However, in the draft standard, the terms, "AC" and "DC" are capitalized. However, in the FAQ Document, "ac" and "dc" are lower case. ATC recommends using capitalization (or lack thereof) related to "AC" and "DC" consistently in both the standard and the FAQ Document.
Response:	We have revised the use of "ac" and "dc" to be consistent throughout the standard and Supplementary Reference and FAQ document per the NERC Style Guide.

<p>Thomas Foltz - AEP - 5 -</p> <p>Selected Answer: Yes</p>																									
<p>Jamison Dye - Bonneville Power Administration - 1,3,5,6 - WECC</p> <p>Selected Answer: Yes</p>																									
<p>Leonard Kula - Independent Electricity System Operator - 2 -</p> <p>Selected Answer: Yes</p>																									
<p>Emily Rousseau - MRO - 1,2,3,4,5,6 - MRO</p> <p>Group Name: MRO-NERC Standards Review Forum (NSRF)</p> <table border="1" style="width: 100%; border-collapse: collapse; margin-top: 10px;"> <thead> <tr> <th style="text-align: left;">Group Member Name</th> <th style="text-align: left;">Entity</th> <th style="text-align: left;">Region</th> <th style="text-align: left;">Segments</th> </tr> </thead> <tbody> <tr> <td>Joe Depoorter</td> <td>Madison Gas & Electric</td> <td>MRO</td> <td>3,4,5,6</td> </tr> <tr> <td>Amy Casucelli</td> <td>Xcel Energy</td> <td>MRO</td> <td>1,3,5,6</td> </tr> <tr> <td>Chuck Lawrence</td> <td>American Transmission Company</td> <td>MRO</td> <td>1</td> </tr> <tr> <td>Chuck Wicklund</td> <td>Otter Tail Power Company</td> <td>MRO</td> <td>1,3,5</td> </tr> <tr> <td>Theresa Allard</td> <td>Minnkota Power Cooperative,</td> <td>MRO</td> <td>1,3,</td> </tr> </tbody> </table>		Group Member Name	Entity	Region	Segments	Joe Depoorter	Madison Gas & Electric	MRO	3,4,5,6	Amy Casucelli	Xcel Energy	MRO	1,3,5,6	Chuck Lawrence	American Transmission Company	MRO	1	Chuck Wicklund	Otter Tail Power Company	MRO	1,3,5	Theresa Allard	Minnkota Power Cooperative,	MRO	1,3,
Group Member Name	Entity	Region	Segments																						
Joe Depoorter	Madison Gas & Electric	MRO	3,4,5,6																						
Amy Casucelli	Xcel Energy	MRO	1,3,5,6																						
Chuck Lawrence	American Transmission Company	MRO	1																						
Chuck Wicklund	Otter Tail Power Company	MRO	1,3,5																						
Theresa Allard	Minnkota Power Cooperative,	MRO	1,3,																						

	Inc		5,6
Dave Rudolph	Basin Electric Power Cooperative	MRO	1,3,5,6
Kayleigh Wilkerson	Lincoln Electric System	MRO	1,3,5,6
Jodi Jenson	Western Area Power Administration	MRO	1,6
Larry Heckert	Alliant Energy	MRO	4
Mahmood Safi	Omaha Public Utility District	MRO	1,3,5,6
Shannon Weaver	Midwest ISO Inc.	MRO	2
Mike Brytowski	Great River Energy	MRO	1,3,5,6
Brad Perrett	Minnesota Power	MRO	1,5
Scott Nickels	Rochester Public Utilities	MRO	4
Terry Harbour	MidAmerican Energy Company	MRO	1,3,5,6
Tom Breene	Wisconsin Public Service Corporation	MRO	3,4,5,6
Tony Eddleman	Nebraska Public Power District	MRO	1,3,5

Selected Answer: Yes

Gul Khan - Gul Khan On Behalf of: Rod Kinard, Oncor Electric Delivery, 1

Selected Answer: Yes

Amy Casuscelli - Xcel Energy, Inc. - 1,3,5,6 - MRO,WECC,SPP

<p>Selected Answer: Yes</p>																				
<p>Adam Padgett - TECO - Tampa Electric Co. - 1,3,4,5 - FRCC</p> <p>Selected Answer: Yes</p>																				
<p>Randi Heise - Dominion - Dominion Resources, Inc. - 5 -</p> <p>Group Name: Dominion - RCS</p> <table border="1"> <thead> <tr> <th>Group Member Name</th> <th>Entity</th> <th>Region</th> <th>Segments</th> </tr> </thead> <tbody> <tr> <td>Larry Nash</td> <td>Dominion Virginia Power</td> <td>SERC</td> <td>1</td> </tr> <tr> <td>Louis Slade</td> <td>Dominion Resources, Inc.</td> <td>SERC</td> <td>6</td> </tr> <tr> <td>Connie Lowe</td> <td>Dominion Resources, Inc.</td> <td>RFC</td> <td>3</td> </tr> <tr> <td>Randi Heise</td> <td>Dominion Resources, Inc,</td> <td>NPCC</td> <td>5</td> </tr> </tbody> </table> <p>Selected Answer: Yes</p>	Group Member Name	Entity	Region	Segments	Larry Nash	Dominion Virginia Power	SERC	1	Louis Slade	Dominion Resources, Inc.	SERC	6	Connie Lowe	Dominion Resources, Inc.	RFC	3	Randi Heise	Dominion Resources, Inc,	NPCC	5
Group Member Name	Entity	Region	Segments																	
Larry Nash	Dominion Virginia Power	SERC	1																	
Louis Slade	Dominion Resources, Inc.	SERC	6																	
Connie Lowe	Dominion Resources, Inc.	RFC	3																	
Randi Heise	Dominion Resources, Inc,	NPCC	5																	
<p>John Coggins - Salt River Project - 3 -</p> <p>Selected Answer: Yes</p>																				
<p>Molly Devine - IDACORP - Idaho Power Company - 1 -</p> <p>Selected Answer: Yes</p>																				

Rachel Coyne - Texas Reliability Entity, Inc. - 10 -

Selected Answer:

Answer Comment:

Texas RE noticed some references to version four of PRC-005, which could cause confusion:

- Page four in the first paragraph, “PRC-005-4 would apply to this equipment”; and
- Page Five in the FAQ section regarding Distribution Provider.

On page 20 of the Supplementary document there is a reference to CBM that appears incorrect (“if the condition of the device is continuously monitored (CBM).”)

Response:

1. The SDT has reviewed the introductory section and revised it to address your comments.
2. The reference to CBM has been removed.

John Seelke - PSEG - 1,3,5,6 - NPCC,RFC

Group Name: PSEG

Group Member Name	Entity	Region	Segments
Joseph Smith	Public Service Electric and Gas	RFC	1

Jeffrey Mueller	Public Service Electric and Gas Co.	RFC	3
Tim Kucey	PSEG Fossil LLC	RFC	5
Karla Jara	PSEG Energy Resources & Trade LLC	RFC	6

Selected Answer: No

Answer Comment: We do not believe this standard is needed.

Response: This standard is developed explicitly to address directives from FERC Order 803. NERC is statutorily obligated to address the directives, either directly or via equally effective actions, and has determined that there are no equally effective alternatives.

Likes: 2 PSEG - Public Service Electric and Gas Co., 1, Smith Joseph
PSEG - PSEG Fossil LLC, 5, Kucey Tim

Dislikes: 0

Mike Smith - Manitoba Hydro - 1 -

Selected Answer: Yes

David Jendras - Ameren - Ameren Services - 3 -

Selected Answer: Yes

Chris Mattson - Tacoma Public Utilities (Tacoma, WA) - 5 -

Selected Answer:

Answer Comment: On page 24 of the redlined version of the Supplementary Reference and FAQ, the bottom box in the flowchart should show R5, not R3.

Response: You are correct. We have revised accordingly.

Lee Pedowicz - Northeast Power Coordinating Council - 10 - NPCC

Group Name: NPCC--Project 2007-17.4 PRC-005 FERC Order No. 803 Directive - PRC-005-6

Group Member Name	Entity	Region	Segments
Alan Adamson	New York State Reliability Council, LLC	NPCC	10
David Burke	Orange and Rockland Utilities Inc.	NPCC	3
Greg Campoli	New York Independent System Operator	NPCC	2
Gerry Dunbar	Northeast Power Coordinating Council	NPCC	10
Mark Kenny	Northeast Utilities	NPCC	1
Helen Lainis	Independent Electricity System Operator	NPCC	2

Rob Vance	New Brunswick Power Corporation	NPCC	9
Paul Malozewski	Hydro One Networks Inc.	NPCC	1
Bruce Metruck	New York Power Authority	NPCC	6
Lee Pedowicz	Northeast Power Coordinating Council	NPCC	10
David Ramkalawan	Ontario Power Generation, Inc.	NPCC	5
Brian Robinson	Utility Services	NPCC	8
Wayne Sipperly	New York Power Authority	NPCC	5
Edward Bedder	Orange and Rockland Utilities Inc.	NPCC	1
Michael Jones	National Grid	NPCC	1
Brian Shanahan	National Grid	NPCC	1
Glen Smith	Entergy Services, Inc.	NPCC	5
RuiDa Shu	Northeast Power Coordinating Council	NPCC	10
Connie Lowe	Dominion Resources Services, Inc.	NPCC	5
Guy Zito	Northeast Power Coordinating Council	NPCC	10
Silvia Parada Mitchell	NextEra Energy, LLC	NPCC	5
Robert Pellegrini	The United Illuminating Company	NPCC	1
Kathleen Goodman	ISO - New England	NPCC	2
Kelly Dash	Consolidated Edison Co. of New York, Inc.	NPCC	1
Michael Forte	Consolidated Edison Co. of New York, Inc.	NPCC	1
Brian O'Boyle	Consolidated Edison Co. of New York, Inc.	NPCC	8
Peter Yost	Consolidated Edison Co. of New	NPCC	3

	York, Inc.		
Sylvain Clermont	Hydro-Quebec TransEnergie	NPCC	1
Si Truc Phan	Hydro-Quebec TransEnergie	NPCC	1

Selected Answer: No

Answer Comment: Suggest a clarification in the definition of a synchronizing or synchronism check relay (Sync-Check - 25) as shown below:

“A synchronizing device that produces an output that supervises closure of a circuit breaker between two circuits whose voltages are within prescribed limits of magnitude and within the prescribed phase angle **for the prescribed time**. It may or may not include voltage or speed control. A sync-check relay permits the paralleling of two circuits that are within prescribed (usually wider) limits of voltage magnitude and phase angle **for the prescribed time**.”

Response: The SDT agrees, and has made the associated editorial change.

Likes: 1 Pathirane Oshani On Behalf of: Paul Malozewski, Hydro One Networks, Inc., 1, 3, Payam Farahbakhsh

Dislikes: 0

Jennifer Losacco - NextEra Energy - Florida Power and Light Co. - 1 - FRCC

Selected Answer: Yes

Jason Smith - Southwest Power Pool, Inc. (RTO) - 2 - SPP

Group Name: SPP Standards Review Group

Group Member Name	Entity	Region	Segments
Shannon Mickens	Southwest Power Pool	SPP	2
Jason Smith	Southwest Power Pool	SPP	2
Karl Diekevers	Nebraska Public Power District	MRO	1,3,5
Allan George	Sunflower Electric Power Corporation	SPP	1
Robert Gray	Board of Public Utilities Kansas City, Kansas	SPP	3
Robert Hirchak	CLECO Corporation	SPP	1,3,5,6
Stephanie Johnson	Westar Energy, Inc.	SPP	1,3,5,6
James Nail	City of Independence, Missouri	SPP	3,5
Scott Williams	City Utilities of Springfield	SPP	1,4

Selected Answer: Yes

Ben Engelby - ACES Power Marketing - 6 -

Group Name: ACES Standards Collaborators - PRC-005 Project

Group Member Name	Entity	Region	Segment
-------------------	--------	--------	---------

		on	me nts
Amber Skillern	East Kentucky Power Cooperative	SERC	1,3
Shari Heino	Brazos Electric Power Cooperative, Inc.	TRE	1,5
Bob Solomon	Hoosier Energy Rural Electric Cooperative, Inc.	RFC	1
Mike Brytowski	Great River Energy	MRO	1,3, 5,6
Ellen Watkins	Sunflower Electric Power Corporation	SPP	1
Ryan Strom	Buckeye Power, Inc.	RFC	4
Ginger Mercier	Prairie Power, Inc.	SERC	1,3
Lucia Beal	Southern Maryland Electric Cooperative	RFC	3

Selected Answer: Yes

Answer Comment:

1. We generally agree with the document, but question the need for listing PRC-005, PRC-008, PRC-011, and PRC-017 in the introduction. This only creates confusion and will need to be revised when these standards are retired. The implementation plan already covers these changes. The introduction should explain the various FERC orders and the rationale for adding additional equipment to the scope of this standard. While we understand that the supplementary reference is not mandatory nor enforceable, it should be drafted in a way that does not require constant updates or maintenance for each new version of the standard.

2. On page 98, the newly added FAQ regarding the parts of the control circuitry that need to be verified should clarify that the numbers listed in the bullets are IEEE device numbers. Also, the format of this question makes it appear that all of the bullets are applicable and need to be verified. The reader must get to the final sentence before they find that three of the six bullets do not need verification. We ask the SDT to reword this question by removing the bullets and clarifying that IEEE device numbers 79, 25, and 27 or 59 would need to be verified while IEEE device numbers 79/ON, 52, and 86 do not.

3. We identified inconsistent capitalization for “AC,” “DC,” and “VAR”. The standard capitalizes these words while the technical reference does not. We recommend that the supplemental reference matches the same usage and capitalization as the standard.

Response:

- 1. The SDT believes that it is necessary to carry this forth, in order to continue to emphasize that PRC-008, PRC-011, and PRC-017 are in force until fully superseded by PRC-005-2 or successor standard.**
- 2. The list of relays is actually part of the question and should have been in bold, italic text. This has been corrected.**
- 3. The SDT has revised the Supplementary Reference to assure consistent use of the terms. We have revised the use of “ac” and “dc” to be consistent throughout the standard and Supplementary Reference and FAQ document per the NERC Style Guide.**

Oshani Pathirane - Oshani Pathirane On Behalf of: Paul Malozewski, Hydro One Networks, Inc., 1, 3

Payam Farahbakhsh, Hydro One Networks, Inc., 1, 3

Selected Answer: Yes

4. The PSMTSDT has proposed combining the Implementation Plans for previous versions of PRC-005 (including PRC-005-3, PRC-005-3i, PRC-005-3ii, PRC-005-4 and PRC-005-5). Do you agree with the proposed Implementation Plan? If not, please provide specific comments regarding the Implementation Plan and any suggestions for alternative language.

John Fontenot - Bryan Texas Utilities - 1 -

Selected Answer: Yes

Meghan Ferguson - International Transmission Company Holdings Corporation On Behalf of: Michael Moltane, International Transmission Company Holdings Corporation, 1

Selected Answer: Yes

Andrew Puztai - American Transmission Company, LLC - 1 -

Selected Answer: Yes

Thomas Foltz - AEP - 5 -

Selected Answer: Yes

Jamison Dye - Bonneville Power Administration - 1,3,5,6 - WECC

Selected Answer: Yes

Leonard Kula - Independent Electricity System Operator - 2 -

Selected Answer: Yes

Emily Rousseau - MRO - 1,2,3,4,5,6 - MRO

Group Name: MRO-NERC Standards Review Forum (NSRF)

Group Member Name	Entity	Region	Segments
Joe Depoorter	Madison Gas & Electric	MRO	3,4,5,6
Amy Casucelli	Xcel Energy	MRO	1,3,5,6
Chuck Lawrence	American Transmission Company	MRO	1
Chuck Wicklund	Otter Tail Power Company	MRO	1,3,5
Theresa Allard	Minnkota Power Cooperative, Inc	MRO	1,3,5,6
Dave Rudolph	Basin Electric Power Cooperative	MRO	1,3,5,6
Kayleigh Wilkerson	Lincoln Electric System	MRO	1,3,5,6
Jodi Jenson	Western Area Power	MRO	1,6

	Administration		
Larry Heckert	Alliant Energy	MRO	4
Mahmood Safi	Omaha Public Utility District	MRO	1,3, 5,6
Shannon Weaver	Midwest ISO Inc.	MRO	2
Mike Brytowski	Great River Energy	MRO	1,3, 5,6
Brad Perrett	Minnesota Power	MRO	1,5
Scott Nickels	Rochester Public Utilities	MRO	4
Terry Harbour	MidAmerican Energy Company	MRO	1,3, 5,6
Tom Breene	Wisconsin Public Service Corporation	MRO	3,4, 5,6
Tony Eddleman	Nebraska Public Power District	MRO	1,3, 5

Selected Answer: No

Answer Comment: The NSRF suggest the following up date as we believe it was a cut and paste error.

Tables 4-2(a), 4-2(b) and 4-3 have a note contained within the header that needs to be corrected. The note states “Note: In cases where Components of **Sudden Pressure Relaying** are common to Components listed in Table...”

The notes in these tables should be changed from Sudden Pressure Relaying to Automatic Reclosing.

Response: Thank you. The SDT agrees that the header blocks are incorrect and have made the associated editorial changes.

<p>Gul Khan - Gul Khan On Behalf of: Rod Kinard, Oncor Electric Delivery, 1</p>	
<p>Selected Answer:</p>	<p>Yes</p>
<p>Amy Casuscelli - Xcel Energy, Inc. - 1,3,5,6 - MRO,WECC,SPP</p>	
<p>Selected Answer:</p>	<p>Yes</p>
<p>Answer Comment:</p>	<p>We strongly support the consolidation of the various PRC-005 Implementation Plans and believe this effort will eliminate much confusion and provide for a much more manageable change process.</p>
<p>Response: Thank you for your support.</p>	
<p>Adam Padgett - TECO - Tampa Electric Co. - 1,3,4,5 - FRCC</p>	
<p>Selected Answer:</p>	<p>Yes</p>
<p>Answer Comment:</p>	<p>Eliminating multiple revisions of this standard will facilitate improved understandability of the standard while reducing the potential for errors in implementing the standard.</p>
<p>Response: Thank you for your support.</p>	

Pamela Hunter - Southern Company - Southern Company Services, Inc. - 1,3,5,6 - SERC

Group Name: Southern Company

Group Member Name	Entity	Region	Segments
Robert A. Schaffeld	Southern Company Services, Inc.	SERC	1
R. Scott Moore	Alabama Power Company	SERC	3
William D. Shultz	Southern Company Generation	SERC	5
John J. Ciza	Southern Company Generation and Energy Marketing	SERC	6

Selected Answer:

Answer Comment: Southern Company supports the proposed implementation plan but, as noted early, feel that the the enforcement date of the already approved PRC-005-3 should immediately be placed on hold in order to coincide with the approval of this version of PRC-005.

Response: FERC, in their recent approval of PRC-005-4 in Order 813, rejected this proposal. The SDT has requested that NERC include a proposal in its petition for PRC-005-6 to accomplish a streamlined implementation plan.

Randi Heise - Dominion - Dominion Resources, Inc. - 5 -

Group Name: Dominion - RCS

Group Member Name	Entity	Region	Segments
Larry Nash	Dominion Virginia Power	SERC	1
Louis Slade	Dominion Resources, Inc.	SERC	6
Connie Lowe	Dominion Resources, Inc.	RFC	3
Randi Heise	Dominion Resources, Inc,	NPCC	5

Selected Answer: Yes

John Coggins - Salt River Project - 3 -

Selected Answer: Yes

Molly Devine - IDACORP - Idaho Power Company - 1 -

Selected Answer: Yes

Answer Comment: With the number of revisions, keeping track is becoming a full time job.

Response: Thank you for your support. – FERC, in their recent approval of PRC-005-4 in Order 813, rejected a proposal to simplify the implementation plan. The SDT has requested that NERC include a proposal in its petition for PRC-005-6 to accomplish a streamlined implementation plan.

Rachel Coyne - Texas Reliability Entity, Inc. - 10 -

Selected Answer: No

Answer Comment:

1. Texas RE understands registered entities need time to implement standards, but the extended timeframes for testing and maintenance of the components in the series of standards listed above is too long. If registered entities are aware of the future need they should already be working to identify the Components (and associated maintenance schedules). Texas RE is concerned there would be significant reliability risk if a registered entity was not maintaining a list of the relays it has implemented and when testing was completed on those implemented relays. The extended timeframe, now possibly beyond 2030, could lead to misinterpretations and inconsistencies in registered entities practices and could impact auditing.

Texas RE made the following additional observations:

2. • There does not appear to be consistent use and applicability of relay types associated with term “relay” (e.g. In Table 4-1 there is a distinction made in Row 1 (page 34) between “microprocessor relays” and “non-microprocessor relays” AND “microprocessor supervisory relays”.) This could lead to confusion. If there is a “non-microprocessor supervisory relay” does an entity need to “Test and, if necessary calibrate”? It appears that verification requirements will apply to reclosing and supervisory relays and an additional requirement for microprocessor supervisory relays has been added. Is that the intent? In Row 2, no distinction is made (i.e. “Verify: Settings are as specified” will apply to both reclosing relays and supervisory relays);

3. • Section 1.3 “Compliance Monitoring and Assessment Processes” does not follow the Standards template; and

4. • In Table 3 “Ac” at the beginning of a sentence on page 32 needs capitalized Page 18 Table 1-1 has similar issue).

Commented [SC1]: Verify correct template is in use.

Response: CWR –

1. The SDT believes that the lengthy implementation plan is necessary for entities to have a sustainable maintenance program. While entities MAY begin to implement the requirements in advance of regulatory approvals, they are under no obligation to do so.
2. The SDT has reviewed and made clarifying edits to the first two bullets to include “reclosing or supervisory”.
3. NERC will review and assure that the relevant template is followed.
4. This error has been corrected.

John Seelke - PSEG - 1,3,5,6 - NPCC,RFC

Group Name: PSEG

Group Member Name	Entity	Region	Segments
Joseph Smith	Public Service Electric and Gas	RFC	1
Jeffrey Mueller	Public Service Electric and Gas Co.	RFC	3
Tim Kucey	PSEG Fossil LLC	RFC	5
Karla Jara	PSEG Energy Resources & Trade	RFC	6

	LLC		
--	-----	--	--

Selected Answer: No

Answer Comment: We do not believe this standard is needed.

Response: This standard is developed explicitly to address directives from FERC Order 803. NERC is statutorily obligated to address the directives, either directly or via equally effective actions, and has determined that there are no equally effective alternatives.

Likes: 2 PSEG - Public Service Electric and Gas Co., 1, Smith Joseph
PSEG - PSEG Fossil LLC, 5, Kucey Tim

Dislikes: 0

Mike Smith - Manitoba Hydro - 1 -

Selected Answer: No

Answer Comment: Manitoba Hydro disagrees with the imposed maintenance requirements introduced in PRC-005-6 through the merging of developed maintenance requirements from PRC-005-4.

Manitoba Hydro disagrees with the 6 calendar year maximum maintenance interval proposed in Table 5, relating to sudden pressure relays. Manitoba Hydro has never seen evidence that maintaining sudden pressure relays will in any way prevent instability, cascading outages, or islanding. If such evidence or peer-reviewed publications exist, please share them. Without

such evidence, enforcing this maintenance falls outside of NERC’s mandate. Moreover, the System Protection and Control Subcommittee (SPCS) errs in believing that it is “more important to base intervals for fault pressure relaying on similar Protection System Components than transformer maintenance intervals.” (p 105 of the “PRC-005-4 Supplementary Reference and FAQ – October 2014”). Justification for this perspective is that maintaining sudden pressure relays necessitates transformer outages, which is not the case with most other protection system component maintenance. To avoid unnecessary reliability risks from these transformer outages, sudden pressure relay maintenance should be based on the transformer maintenance intervals, which in Manitoba Hydro’s case greatly exceeds six years.

As proposed, PRC-005-6 is mandating a reduction in the availability of equipment (transformers), reducing the reliability of the BES during these maintenance forced outages, without providing any additional security to the BES. The maintenance frequency appears to be arbitrarily aligned with maintenance intervals of other protective systems, which do not require outages or impose notable reliability risks to the BES during such maintenance.

Response: Sudden pressure relays were added in previously approved PRC-005-4; any additional consideration of these devices is out of scope for PRC-005-6.

David Jendras - Ameren - Ameren Services - 3 -

Selected Answer: Yes

Colby Bellville - Duke Energy - 1,3,5,6 - FRCC,SERC,RFC

Group Name: Duke Energy

Group Member Name	Entity	Region	Segments
Doug Hils	Duke Energy	RFC	1
Lee Schuster	Duke Energy	FRCC	3
Dale Goodwine	Duke Energy	SERC	5
Greg Cecil	Duke Energy	RFC	6

Selected Answer: Yes

Answer Comment: Duke Energy is supportive of the proposal to combine the Implementation Plans for all of the listed versions of PRC-005. Based on the approaching effective date of PRC-005-3, we encourage that the proposal to combine all Implementation Plans be considered and approved prior to PRC-005-3 effective date.

Response: Thank you for your support. FERC, in their recent approval of PRC-005-4 in Order 813, rejected suggestions to combine the implementation plans. The SDT has requested that NERC include a proposal in its petition for PRC-005-6 to accomplish a streamlined implementation plan.

Chris Mattson - Tacoma Public Utilities (Tacoma, WA) - 5 -

Selected Answer: Yes

Lee Pedowicz - Northeast Power Coordinating Council - 10 - NPCC

Group Name: NPCC--Project 2007-17.4 PRC-005 FERC Order No. 803
Directive - PRC-005-6

Group Member Name	Entity	Region	Segments
Alan Adamson	New York State Reliability Council, LLC	NPCC	10
David Burke	Orange and Rockland Utilities Inc.	NPCC	3
Greg Campoli	New York Independent System Operator	NPCC	2
Gerry Dunbar	Northeast Power Coordinating Council	NPCC	10
Mark Kenny	Northeast Utilities	NPCC	1
Helen Lainis	Independent Electricity System Operator	NPCC	2
Rob Vance	New Brunswick Power Corporation	NPCC	9
Paul Malozewski	Hydro One Networks Inc.	NPCC	1
Bruce Metruck	New York Power Authority	NPCC	6
Lee Pedowicz	Northeast Power Coordinating Council	NPCC	10
David Ramkalawan	Ontario Power Generation, Inc.	NPCC	5
Brian Robinson	Utility Services	NPCC	8
Wayne Sipperly	New York Power Authority	NPCC	5
Edward Bedder	Orange and Rockland Utilities	NPCC	1

	Inc.		
Michael Jones	National Grid	NPCC	1
Brian Shanahan	National Grid	NPCC	1
Glen Smith	Entergy Services, Inc.	NPCC	5
RuiDa Shu	Northeast Power Coordinating Council	NPCC	10
Connie Lowe	Dominion Resources Services, Inc.	NPCC	5
Guy Zito	Northeast Power Coordinating Council	NPCC	10
Silvia Parada Mitchell	NextEra Energy, LLC	NPCC	5
Robert Pellegrini	The United Illuminating Company	NPCC	1
Kathleen Goodman	ISO - New England	NPCC	2
Kelly Dash	Consolidated Edison Co. of New York, Inc.	NPCC	1
Michael Forte	Consolidated Edison Co. of New York, Inc.	NPCC	1
Brian O'Boyle	Consolidated Edison Co. of New York, Inc.	NPCC	8
Peter Yost	Consolidated Edison Co. of New York, Inc.	NPCC	3
Sylvain Clermont	Hydro-Quebec TransEnergie	NPCC	1
Si Truc Phan	Hydro-Quebec TransEnergie	NPCC	1

Selected Answer: Yes

Jennifer Losacco - NextEra Energy - Florida Power and Light Co. - 1 - FRCC

Selected Answer: Yes

Jason Smith - Southwest Power Pool, Inc. (RTO) - 2 - SPP

Group Name: SPP Standards Review Group

Group Member Name	Entity	Region	Segments
Shannon Mickens	Southwest Power Pool	SPP	2
Jason Smith	Southwest Power Pool	SPP	2
Karl Diekevers	Nebraska Public Power District	MRO	1,3,5
Allan George	Sunflower Electric Power Corporation	SPP	1
Robert Gray	Board of Public Utilities Kansas City, Kansas	SPP	3
Robert Hirchak	CLECO Corporation	SPP	1,3,5,6
Stephanie Johnson	Westar Energy, Inc.	SPP	1,3,5,6
James Nail	City of Independence, Missouri	SPP	3,5
Scott Williams	City Utilities of Springfield	SPP	1,4

Selected Answer: Yes

Answer Comment: The proposed implementation plan and request by NERC to align the implementations seem to address prior concerns with the staggered and confusing implementation dates. Thank you for the effort.

Response: Thank you for your support.

Ben Engelby - ACES Power Marketing - 6 -

Group Name: ACES Standards Collaborators - PRC-005 Project

Group Member Name	Entity	Region	Segments
Amber Skillern	East Kentucky Power Cooperative	SERC	1,3
Shari Heino	Brazos Electric Power Cooperative, Inc.	TRE	1,5
Bob Solomon	Hoosier Energy Rural Electric Cooperative, Inc.	RFC	1
Mike Brytowski	Great River Energy	MRO	1,3,5,6
Ellen Watkins	Sunflower Electric Power Corporation	SPP	1
Ryan Strom	Buckeye Power, Inc.	RFC	4
Ginger Mercier	Prairie Power, Inc.	SERC	1,3
Lucia Beal	Southern Maryland Electric Cooperative	RFC	3

Selected Answer: Yes

Answer Comment: We believe that unless there is an urgent reliability gap, revisions to PRC-005 should be limited to no more than once per year. Frequent modifications to these requirements can have detrimental effects on electric system reliability due to rushed standards development and the possibility of

inadequately reviewed relay test plans.

While we agree with the approach in the current implementation plan, we question the process of having multiple versions that have resulted in the conundrum that we face today. Each effective version of PRC-005 should supersede all previous versions and include all current requirements for clarity. We understand and appreciate that there are varied implementation dates for different requirements, but maintaining multiple versions is cumbersome, burdensome, and creates risk that a requirement is missed. We believe confusion would be alleviated if the NERC Standards Department had a policy of requiring each standard revision have a whole number for the next applicable version. For example, if PRC-005-2 is to be superseded, then PRC-005-2 would be retired and PRC-005-“3” would take precedence. We strongly urge NERC to discontinue the practice of creating sub-sets with standard versions, such as “PRC-005-2(i)”.

Response: Thank you for your support. As you note, there has been considerable standard development activity on PRC-005, and the SDT likewise hopes that need for frequent revisions will abate.

End of Report

Standard Development Timeline

This section is maintained by the drafting team during the development of the standard and will be removed when the standard becomes effective.

Development Steps Completed

1. SAR posted for comment March 12 – April 10, 2015.
2. Revised SAR reposted with revisions for comment June 11 – July 10, 2015

Description of Current Draft

This version of PRC-005 was posted for a 45-day concurrent comment and ballot period to address directives from [FERC Order No. 803](#), addressing Automatic Reclosing. Specifically, supervisory relays, associated voltage sensing devices, and associated control circuitry were added.

Anticipated Actions	Anticipated Dates
45-day Formal Comment Period with Concurrent Ballot	July 2015 – September 2015
Final ballot	October 2015
BOT adoption	November 2015

Definitions of Terms Used in Standard

This section includes all newly defined or revised terms used in the proposed standard. Terms already defined in the Reliability Standards Glossary of Terms (Glossary) are not repeated here. New or revised definitions listed below become approved when the proposed standard is approved. When the standard becomes effective, this defined term will be removed from the individual standard and added to the Glossary.

[See Section 6 of the Standard](#)

A. Introduction

1. **Title:** Protection System, Automatic Reclosing, and Sudden Pressure Relaying Maintenance
2. **Number:** PRC-005-6
3. **Purpose:** To document and implement programs for the maintenance of all Protection Systems, Automatic Reclosing, and Sudden Pressure Relaying affecting the reliability of the Bulk Electric System (BES) so that they are kept in working order.
4. **Applicability:**
 - 4.1. **Functional Entities:**
 - 4.1.1 Transmission Owner
 - 4.1.2 Generator Owner
 - 4.1.3 Distribution Provider
 - 4.2. **Facilities:**
 - 4.2.1 Protection Systems and Sudden Pressure Relaying that are installed for the purpose of detecting Faults on BES Elements (lines, buses, transformers, etc.)
 - 4.2.2 Protection Systems used for underfrequency load-shedding systems installed per ERO underfrequency load-shedding requirements.
 - 4.2.3 Protection Systems used for undervoltage load-shedding systems installed to prevent system voltage collapse or voltage instability for BES reliability.
 - 4.2.4 Protection Systems installed as a Remedial Action Scheme (RAS) for BES reliability.
 - 4.2.5 Protection Systems and Sudden Pressure Relaying for generator Facilities that are part of the BES, except for generators identified through Inclusion I4 of the BES definition, including:
 - 4.2.5.1 Protection Systems that act to trip the generator either directly or via lockout or auxiliary tripping relays.
 - 4.2.5.2 Protection Systems and Sudden Pressure Relaying for generator step-up transformers for generators that are part of the BES.
 - 4.2.5.3 Protection Systems and Sudden Pressure Relaying for station service or excitation transformers connected to the generator bus of generators which are part of the BES, that act to trip the generator either directly or via lockout or tripping auxiliary relays.

4.2.6 Protection Systems and Sudden Pressure Relaying for the following BES generator Facilities for dispersed power producing resources identified through Inclusion I4 of the BES definition:

4.2.6.1 Protection Systems and Sudden Pressure Relaying for Facilities used in aggregating dispersed BES generation from the point where those resources aggregate to greater than 75 MVA to a common point of connection at 100kV or above.

4.2.7 Automatic Reclosing¹, including:

4.2.7.1 Automatic Reclosing applied on the terminals of Elements connected to the BES bus located at generating plant substations where the total installed gross generating plant capacity is greater than the gross capacity of the largest BES generating unit within the Balancing Authority Area or, if a member of a Reserve Sharing Group, the largest generating unit within the Reserve Sharing Group.²

4.2.7.2 Automatic Reclosing applied on the terminals of all BES Elements at substations one bus away from generating plants specified in Section 4.2.7.1 when the substation is less than 10 circuit-miles from the generating plant substation.

4.2.7.3 Automatic Reclosing applied as an integral part of an RAS specified in Section 4.2.4.

5. Effective Date: See the Implementation Plan for this standard.

6. Definitions Used in this Standard:

¹ Automatic Reclosing addressed in Section 4.2.7.1 and 4.2.7.2 may be excluded if the equipment owner can demonstrate that a close-in three-phase fault present for twice the normal clearing time (capturing a minimum trip-close-trip time delay) does not result in a total loss of gross generation in the Interconnection exceeding the gross capacity of the largest relevant BES generating unit where the Automatic Reclosing is applied.

² The largest BES generating unit within the Balancing Authority Area or the largest generating unit within the Reserve Sharing Group, as applicable, is subject to change. As a result of such a change, the Automatic Reclosing Components subject to the standard could change effective on the date of such change.

Automatic Reclosing – Includes the following Components:

- Reclosing relay
- Supervisory relay(s) or function(s) – relay(s) or function(s) that perform voltage and/or sync check functions that enable or disable operation of the reclosing relay
- Voltage sensing devices associated with the supervisory relay(s) or function(s)
- Control circuitry associated with the reclosing relay or supervisory relay(s) or function(s)

Rationale for revisions to Automatic Reclosing: To address directives from FERC Order No. 803 addressing Automatic Reclosing, the definition for Automatic Reclosing was revised to add supervisory relays, the associated voltage sensing devices, and the associated control circuitry.

Sudden Pressure Relaying – A system that trips an interrupting device(s) to isolate the equipment it is monitoring and includes the following Components:

- Fault pressure relay – a mechanical relay or device that detects rapid changes in gas pressure, oil pressure, or oil flow that are indicative of Faults within liquid-filled, wire-wound equipment
- Control circuitry associated with a fault pressure relay

Unresolved Maintenance Issue – A deficiency identified during a maintenance activity that causes the Component to not meet the intended performance, cannot be corrected during the maintenance interval, and requires follow-up corrective action.

Segment – Components of a consistent design standard, or a particular model or type from a single manufacturer that typically share other common elements. Consistent performance is expected across the entire population of a Segment. A Segment must contain at least sixty (60) individual Components.

Component Type –

- Any one of the five specific elements of a Protection System
- Any one of the four specific elements of Automatic Reclosing
- Any one of the two specific elements of Sudden Pressure Relaying

Rationale for revisions to Component Type: With the revision of the definition of Automatic Reclosing, there are four specific elements of this definition, rather than two as stated in the prior version.

Component – Any individual discrete piece of equipment included in a Protection System, Automatic Reclosing, or Sudden Pressure Relaying.

Countable Event – A failure of a Component requiring repair or replacement, any condition discovered during the maintenance activities in Tables 1-1 through 1-5, Table 3, Tables 4-1 through 4-3, and Table 5, which requires corrective action or a Protection System Misoperation attributed to hardware failure or calibration failure. Misoperations due to product design errors, software errors, relay settings different from specified settings, Protection System Component, Automatic Reclosing, or Sudden Pressure Relaying configuration or application errors are not included in Countable Events.

B. Requirements and Measures

- R1.** Each Transmission Owner, Generator Owner, and Distribution Provider shall establish a Protection System Maintenance Program (PSMP) for its Protection Systems, Automatic Reclosing, and Sudden Pressure Relaying identified in Section 4.2, Facilities. *[Violation Risk Factor: Medium] [Time Horizon: Operations Planning]*

The PSMP shall:

- 1.1.** Identify which maintenance method (time-based, performance-based per PRC-005 Attachment A, or a combination) is used to address each Protection System, Automatic Reclosing, and Sudden Pressure Relaying Component Type. All batteries associated with the station dc supply Component Type of a Protection System shall be included in a time-based program as described in Table 1-4 and Table 3.
 - 1.2.** Include the applicable monitored Component attributes applied to each Protection System, Automatic Reclosing, and Sudden Pressure Relaying Component Type consistent with the maintenance intervals specified in Tables 1-1 through 1-5, Table 2, Table 3, Table 4-1 through 4-3, and Table 5 where monitoring is used to extend the maintenance intervals beyond those specified for unmonitored Protection System, Automatic Reclosing, and Sudden Pressure Relaying Components.
- M1.** Each Transmission Owner, Generator Owner and Distribution Provider shall have a documented PSMP in accordance with Requirement R1.

For each Protection System, Automatic Reclosing, and Sudden Pressure Relaying Component Type, the documentation shall include the type of maintenance method applied (time-based, performance-based, or a combination of these maintenance methods), and shall include all batteries associated with the station dc supply Component Types in a time-based program as described in Table 1-4 and Table 3. (Part 1.1)

For Component Types that use monitoring to extend the maintenance intervals, the responsible entity(s) shall have evidence for each Protection System, Automatic Reclosing, and Sudden Pressure Relaying Component Type (such as manufacturer's specifications or engineering drawings) of the appropriate monitored Component

attributes as specified in Tables 1-1 through 1-5, Table 2, Table 3, Table 4-1 through 4-3, and Table 5. (Part 1.2)

- R2.** Each Transmission Owner, Generator Owner, and Distribution Provider that uses performance-based maintenance intervals in its PSMP shall follow the procedure established in PRC-005 Attachment A to establish and maintain its performance-based intervals. *[Violation Risk Factor: Medium] [Time Horizon: Operations Planning]*
- M2.** Each Transmission Owner, Generator Owner, and Distribution Provider that uses performance-based maintenance intervals shall have evidence that its current performance-based maintenance program(s) is in accordance with Requirement R2, which may include, but is not limited to, Component lists, dated maintenance records, and dated analysis records and results.
- R3.** Each Transmission Owner, Generator Owner, and Distribution Provider that utilizes time-based maintenance program(s) shall maintain its Protection System, Automatic Reclosing, and Sudden Pressure Relaying Components that are included within the time-based maintenance program in accordance with the minimum maintenance activities and maximum maintenance intervals prescribed within Tables 1-1 through 1-5, Table 2, Table 3, Table 4-1 through 4-3, and Table 5. *[Violation Risk Factor: High] [Time Horizon: Operations Planning]*
- M3.** Each Transmission Owner, Generator Owner, and Distribution Provider that utilizes time-based maintenance program(s) shall have evidence that it has maintained its Protection System, Automatic Reclosing, and Sudden Pressure Relaying Components included within its time-based program in accordance with Requirement R3. The evidence may include, but is not limited to, dated maintenance records, dated maintenance summaries, dated check-off lists, dated inspection records, or dated work orders.
- R4.** Each Transmission Owner, Generator Owner, and Distribution Provider that utilizes performance-based maintenance program(s) in accordance with Requirement R2 shall implement and follow its PSMP for its Protection System, Automatic Reclosing, and Sudden Pressure Relaying Components that are included within the performance-based program(s). *[Violation Risk Factor: High] [Time Horizon: Operations Planning]*
- M4.** Each Transmission Owner, Generator Owner, and Distribution Provider that utilizes performance-based maintenance intervals in accordance with Requirement R2 shall have evidence that it has implemented the PSMP for the Protection System, Automatic Reclosing, and Sudden Pressure Relaying Components included in its performance-based program in accordance with Requirement R4. The evidence may include, but is not limited to, dated maintenance records, dated maintenance summaries, dated check-off lists, dated inspection records, or dated work orders.
- R5.** Each Transmission Owner, Generator Owner, and Distribution Provider shall demonstrate efforts to correct identified Unresolved Maintenance Issues. *[Violation Risk Factor: Medium] [Time Horizon: Operations Planning]*

- M5.** Each Transmission Owner, Generator Owner, and Distribution Provider shall have evidence that it has undertaken efforts to correct identified Unresolved Maintenance Issues in accordance with Requirement R5. The evidence may include, but is not limited to, work orders, replacement Component orders, invoices, project schedules with completed milestones, return material authorizations (RMAs) or purchase orders.

C. Compliance

1. Compliance Monitoring Process

1.1. Compliance Enforcement Authority

As defined in the NERC Rules of Procedure, “Compliance Enforcement Authority” means NERC or the Regional Entity in their respective roles of monitoring and enforcing compliance with the NERC Reliability Standards.

1.2. Evidence Retention

The following evidence retention periods identify the period of time an entity is required to retain specific evidence to demonstrate compliance. For instances where the evidence retention period specified below is shorter than the time since the last audit, the Compliance Enforcement Authority may ask an entity to provide other evidence to show that it was compliant for the full time period since the last audit.

The Transmission Owner, Generator Owner, and Distribution Provider shall each keep data or evidence to show compliance as identified below unless directed by its Compliance Enforcement Authority to retain specific evidence for a longer period of time as part of an investigation.

For Requirement R1, the Transmission Owner, Generator Owner, and Distribution Provider shall each keep its current dated PSMP, as well as any superseded versions since the preceding compliance audit, including the documentation that specifies the type of maintenance program applied for each Protection System, Automatic Reclosing, or Sudden Pressure Relaying Component Type.

For Requirement R2, Requirement R3, and Requirement R4, in cases where the interval of the maintenance activity is longer than the audit cycle, the Transmission Owner, Generator Owner, and Distribution Provider shall each keep documentation of the most recent performance of that maintenance activity for the Protection System, Automatic Reclosing, or Sudden Pressure Relaying Component. In cases where the interval of the maintenance activity is shorter than the audit cycle, documentation of all performances (in accordance with the tables) of that maintenance activity for the Protection System,

Automatic Reclosing, or Sudden Pressure Relaying Component since the previous scheduled audit date shall be retained.

For Requirement R5 the Transmission Owner, Generator Owner, and Distribution Provider shall each keep documentation of Unresolved Maintenance Issues identified by the entity since the last audit, including all that were resolved since the last audit.

1.3. Compliance Monitoring and Assessment Processes:

Compliance Audits

Self-Certifications

Spot Checking

Compliance Investigations

Self-Reporting

Complaints

1.4. Additional Compliance Information

None

Table of Compliance Elements

Requirement Number	Lower VSL	Moderate VSL	High VSL	Severe VSL
R1	The entity's PSMP failed to specify whether one Component Type is being addressed by time-based or performance-based maintenance, or a combination of both (Part 1.1).	The entity's PSMP failed to specify whether two Component Types are being addressed by time-based or performance-based maintenance, or a combination of both (Part 1.1).	<p>The entity's PSMP failed to specify whether three Component Types are being addressed by time-based or performance-based maintenance, or a combination of both. (Part 1.1).</p> <p style="text-align: center;">OR</p> <p>The entity's PSMP failed to include the applicable monitoring attributes applied to each Component Type consistent with the maintenance intervals specified in Tables 1-1 through 1-5, Table 2, Table 3, Tables 4-1 through 4-3, and Table 5 where monitoring is used to extend the maintenance intervals beyond those specified for unmonitored Components (Part 1.2).</p>	<p>The entity failed to establish a PSMP.</p> <p style="text-align: center;">OR</p> <p>The entity's PSMP failed to specify whether four or more Component Types are being addressed by time-based or performance-based maintenance, or a combination of both (Part 1.1).</p> <p style="text-align: center;">OR</p> <p>The entity's PSMP failed to include applicable station batteries in a time-based program (Part 1.1).</p>
R2	The entity uses performance-based maintenance intervals in its PSMP but failed to reduce Countable Events to no more than 4% within three years.	NA	The entity uses performance-based maintenance intervals in its PSMP but failed to reduce Countable Events to no more than 4% within four years.	<p>The entity uses performance-based maintenance intervals in its PSMP but:</p> <ol style="list-style-type: none"> 1) Failed to establish the technical justification described within Requirement R2 for the initial use of the performance-based PSMP <p style="text-align: center;">OR</p> <ol style="list-style-type: none"> 2) Failed to reduce Countable Events to no more than 4% within five years <p style="text-align: center;">OR</p>

Requirement Number	Lower VSL	Moderate VSL	High VSL	Severe VSL
				3) Maintained a Segment with less than 60 Components OR 4) Failed to: <ul style="list-style-type: none"> • Annually update the list of Components, OR • Annually perform maintenance on the greater of 5% of the Segment population or 3 Components, OR • Annually analyze the program activities and results for each Segment.
R3	For Components included within a time-based maintenance program, the entity failed to maintain 5% or less of the total Components included within a specific Component Type in accordance with the minimum maintenance activities and maximum maintenance intervals prescribed within Tables 1-1 through 1-5, Table 2, Table 3, Tables 4-1 through 4-3, and Table 5.	For Components included within a time-based maintenance program, the entity failed to maintain more than 5% but 10% or less of the total Components included within a specific Component Type in accordance with the minimum maintenance activities and maximum maintenance intervals prescribed within Tables 1-1 through 1-5, Table 2, Table 3, Tables 4-1 through 4-3, and Table 5.	For Components included within a time-based maintenance program, the entity failed to maintain more than 10% but 15% or less of the total Components included within a specific Component Type in accordance with the minimum maintenance activities and maximum maintenance intervals prescribed within Tables 1-1 through 1-5, Table 2, Table 3, Tables 4-1 through 4-3, and Table 5.	For Components included within a time-based maintenance program, the entity failed to maintain more than 15% of the total Components included within a specific Component Type in accordance with the minimum maintenance activities and maximum maintenance intervals prescribed within Tables 1-1 through 1-5, Table 2, Table 3, Tables 4-1 through 4-3, and Table 5.

Requirement Number	Lower VSL	Moderate VSL	High VSL	Severe VSL
R4	For Components included within a performance-based maintenance program, the entity failed to maintain 5% or less of the annual scheduled maintenance for a specific Component Type in accordance with their performance-based PSMP.	For Components included within a performance-based maintenance program, the entity failed to maintain more than 5% but 10% or less of the annual scheduled maintenance for a specific Component Type in accordance with their performance-based PSMP.	For Components included within a performance-based maintenance program, the entity failed to maintain more than 10% but 15% or less of the annual scheduled maintenance for a specific Component Type in accordance with their performance-based PSMP.	For Components included within a performance-based maintenance program, the entity failed to maintain more than 15% of the annual scheduled maintenance for a specific Component Type in accordance with their performance-based PSMP.
R5	The entity failed to undertake efforts to correct 5 or fewer identified Unresolved Maintenance Issues.	The entity failed to undertake efforts to correct greater than 5 but less than or equal to 10 identified Unresolved Maintenance Issues.	The entity failed to undertake efforts to correct greater than 10 but less than or equal to 15 identified Unresolved Maintenance Issues.	The entity failed to undertake efforts to correct greater than 15 identified Unresolved Maintenance Issues.

D. Regional Variances

None.

E. Interpretations

None.

Supplemental Reference Documents

The following documents present a detailed discussion about determination of maintenance intervals and other useful information regarding establishment of a maintenance program.

1. *Supplementary Reference and FAQ - PRC-005-6 Protection System Maintenance*, Protection System Maintenance and Testing Standard Drafting Team (July 2015)
2. *Considerations for Maintenance and Testing of Auto-reclosing Schemes*, NERC System Analysis and Modeling Subcommittee, and NERC System Protection and Control Subcommittee (November 2012)
3. *Sudden Pressure Relays and Other Devices that Respond to Non-Electrical Quantities – SPCS Input for Standard Development in Response to FERC Order No. 758*, NERC System Protection and Control Subcommittee (December 2013)
4. *Sudden Pressure Relays and Other Devices that Respond to Non-Electrical Quantities – Supplemental Information to Support Project 2007-17.3: Protection System Maintenance and Testing* (October 31, 2014)

Version History

Version	Date	Action	Change Tracking
0	February 8, 2005	Adopted by NERC Board of Trustees	New.
1	February 7, 2006	Adopted by NERC Board of Trustees	<ol style="list-style-type: none"> 1. Changed incorrect use of certain hyphens (-) to “en dash” (–) and “em dash (—).” 2. Added “periods” to items where appropriate. Changed “Timeframe” to “Time Frame” in item D, 1.2.
1a	February 17, 2011	Adopted by NERC Board of Trustees	Added Appendix 1 - Interpretation regarding applicability of standard to protection of radially connected transformers developed in Project 2009-17.

Version	Date	Action	Change Tracking
1b	November 5, 2009	Adopted by NERC Board of Trustees	Interpretation of R1, R1.1, and R1.2 developed by Project 2009-10.
1b	February 3, 2012	FERC Order approving revised definition of “Protection System”	Per footnote 8 of FERC’s order, the definition of “Protection System” supersedes interpretation “b” of PRC-005-1b upon the effective date of the modified definition (i.e., April 1, 2013). <i>See N. Amer. Elec. Reliability Corp., 138 FERC ¶ 61,095 (February 3, 2012).</i>
1.1b	May 9, 2012	Adopted by NERC Board of Trustees	Errata change developed by Project 2010-07, clarified inclusion of generator interconnection Facility in Generator Owner’s responsibility.
2	November 7, 2012	Adopted by NERC Board of Trustees	Project 2007-17 - Complete revision, absorbing maintenance requirements from PRC-005-1.1b, PRC-008-0, PRC-011-0, PRC-017-0.
2	October 17, 2013	Approved by NERC Standards Committee	Errata Change: The Standards Committee approved an errata change to the implementation plan for PRC-005-2 to add the phrase “or as otherwise made effective pursuant to the laws applicable to such ERO governmental authorities;” to the second sentence under the “Retirement of Existing Standards” section. (no change to standard version number)
2	March 7, 2014	Adopted by NERC Board of Trustees	Modified R1 VSL in response to FERC directive (no change to standard version number).
2(i)	November 13, 2014	Adopted by NERC Board of Trustees	Applicability section revised by Project 2014-01 to clarify application of Requirements to BES dispersed power producing resources.

Version	Date	Action	Change Tracking
2(ii)	November 13, 2014	Adopted by NERC Board of Trustees	Replaced references to Special Protection System and SPS with Remedial Action Scheme and RAS.
3	November 7, 2013	Adopted by the NERC Board of Trustees	Revised to address the FERC directive in Order No. 758 to include Automatic Reclosing in maintenance programs.
3	February 12, 2014	Approved by NERC Standards Committee	Errata Change: The Standards Committee approved errata changes to correct capitalization of certain defined terms within the definitions of “Unresolved Maintenance Issue” and “Protection System Maintenance Program”. The changes will be reflected in the definitions section of PRC-005-3 for “Unresolved Maintenance Issue” and in the NERC Glossary of Terms for “Protection System Maintenance Program”. (no change to standard version number)
3	March 7, 2014	Adopted by NERC Board of Trustees	Modified R1 VSL in response to FERC directive (no change to standard version number).
3(i)	November 13, 2014	Adopted by NERC Board of Trustees	Applicability section revised by Project 2014-01 to clarify application of Requirements to BES dispersed power producing resources.
3(ii)	November 13, 2014	Adopted by NERC Board of Trustees	Replaced references to Special Protection System and SPS with Remedial Action Scheme and RAS.
4	November 13, 2014	Adopted by NERC Board of Trustees	Added Sudden Pressure Relaying in response to FERC Order No. 758.

Version	Date	Action	Change Tracking
5	May 7, 2015	Adopted by NERC Board of Trustees	Applicability section revised by Project 2014-01 to clarify application of Requirements to BES dispersed power producing resources.
6	TBD		Revised to add supervisory relays, the voltage sensing devices, and the associated control circuitry to Automatic Reclosing in accordance with the directives in FERC Order 803.

Table 1-1 Component Type - Protective Relay Excluding distributed UFLS and distributed UVLS (see Table 3)		
Component Attributes	Maximum Maintenance Interval ³	Maintenance Activities
Any unmonitored protective relay not having all the monitoring attributes of a category below.	6 Calendar Years	For all unmonitored relays: <ul style="list-style-type: none"> • Verify that settings are as specified For non-microprocessor relays: <ul style="list-style-type: none"> • Test and, if necessary calibrate For microprocessor relays: <ul style="list-style-type: none"> • Verify operation of the relay inputs and outputs that are essential to proper functioning of the Protection System. • Verify acceptable measurement of power system input values.
Monitored microprocessor protective relay with the following: <ul style="list-style-type: none"> • Internal self-diagnosis and alarming (see Table 2). • Voltage and/or current waveform sampling three or more times per power cycle, and conversion of samples to numeric values for measurement calculations by microprocessor electronics. • Alarming for power supply failure (see Table 2). 	12 Calendar Years	Verify: <ul style="list-style-type: none"> • Settings are as specified. • Operation of the relay inputs and outputs that are essential to proper functioning of the Protection System. • Acceptable measurement of power system input values.

³ For the tables in this standard, a calendar year starts on the first day of a new year (January 1) after a maintenance activity has been completed. For the tables in this standard, a calendar month starts on the first day of the first month after a maintenance activity has been completed.

Table 1-1 Component Type - Protective Relay Excluding distributed UFLS and distributed UVLS (see Table 3)		
Component Attributes	Maximum Maintenance Interval ³	Maintenance Activities
Monitored microprocessor protective relay with preceding row attributes and the following: <ul style="list-style-type: none"> • Ac measurements are continuously verified by comparison to an independent ac measurement source, with alarming for excessive error (See Table 2). • Some or all binary or status inputs and control outputs are monitored by a process that continuously demonstrates ability to perform as designed, with alarming for failure (See Table 2). • Alarming for change of settings (See Table 2). 	12 Calendar Years	Verify only the unmonitored relay inputs and outputs that are essential to proper functioning of the Protection System.

Table 1-2 Component Type - Communications Systems Excluding distributed UFLS and distributed UVLS (see Table 3)		
Component Attributes	Maximum Maintenance Interval	Maintenance Activities
Any unmonitored communications system necessary for correct operation of protective functions, and not having all the monitoring attributes of a category below.	4 Calendar Months	Verify that the communications system is functional.
	6 Calendar Years	Verify that the communications system meets performance criteria pertinent to the communications technology applied (e.g. signal level, reflected power, or data error rate). Verify operation of communications system inputs and outputs that are essential to proper functioning of the Protection System.
Any communications system with continuous monitoring or periodic automated testing for the presence of the channel function, and alarming for loss of function (See Table 2).	12 Calendar Years	Verify that the communications system meets performance criteria pertinent to the communications technology applied (e.g. signal level, reflected power, or data error rate). Verify operation of communications system inputs and outputs that are essential to proper functioning of the Protection System.
Any communications system with all of the following: <ul style="list-style-type: none"> • Continuous monitoring or periodic automated testing for the performance of the channel using criteria pertinent to the communications technology applied (e.g. signal level, reflected power, or data error rate, and alarming for excessive performance degradation). (See Table 2) • Some or all binary or status inputs and control outputs are monitored by a process that continuously demonstrates ability to perform as designed, with alarming for failure (See Table 2). 	12 Calendar Years	Verify only the unmonitored communications system inputs and outputs that are essential to proper functioning of the Protection System

Table 1-3 Component Type - Voltage and Current Sensing Devices Providing Inputs to Protective Relays Excluding distributed UFLS and distributed UVLS (see Table 3)		
Component Attributes	Maximum Maintenance Interval	Maintenance Activities
Any voltage and current sensing devices not having monitoring attributes of the category below.	12 Calendar Years	Verify that current and voltage signal values are provided to the protective relays.
Voltage and Current Sensing devices connected to microprocessor relays with ac measurements that are continuously verified by comparison of sensing input value, as measured by the microprocessor relay, to an independent ac measurement source, with alarming for unacceptable error or failure (see Table 2).	No periodic maintenance specified	None.

Table 1-4(a) Component Type – Protection System Station dc Supply Using Vented Lead-Acid (VLA) Batteries Excluding distributed UFLS and distributed UVLS (see Table 3)		
Protection System Station dc supply used only for non-BES interrupting devices for RAS, non-distributed UFLS systems, or non-distributed UVLS systems is excluded (see Table 1-4(e)).		
Component Attributes	Maximum Maintenance Interval	Maintenance Activities
Protection System Station dc supply using Vented Lead-Acid (VLA) batteries not having monitoring attributes of Table 1-4(f).	4 Calendar Months	Verify: <ul style="list-style-type: none"> • Station dc supply voltage Inspect: <ul style="list-style-type: none"> • Electrolyte level • For unintentional grounds
	18 Calendar Months	Verify: <ul style="list-style-type: none"> • Float voltage of battery charger • Battery continuity • Battery terminal connection resistance • Battery intercell or unit-to-unit connection resistance Inspect: <ul style="list-style-type: none"> • Cell condition of all individual battery cells where cells are visible – or measure battery cell/unit internal ohmic values where the cells are not visible • Physical condition of battery rack

<p style="text-align: center;">Table 1-4(a) Component Type – Protection System Station dc Supply Using Vented Lead-Acid (VLA) Batteries Excluding distributed UFLS and distributed UVLS (see Table 3)</p> <p style="text-align: center;">Protection System Station dc supply used only for non-BES interrupting devices for RAS, non-distributed UFLS systems, or non-distributed UVLS systems is excluded (see Table 1-4(e)).</p>		
Component Attributes	Maximum Maintenance Interval	Maintenance Activities
	18 Calendar Months -or- 6 Calendar Years	Verify that the station battery can perform as manufactured by evaluating cell/unit measurements indicative of battery performance (e.g. internal ohmic values or float current) against the station battery baseline. -or- Verify that the station battery can perform as manufactured by conducting a performance or modified performance capacity test of the entire battery bank.

Table 1-4(b) Component Type – Protection System Station dc Supply Using Valve-Regulated Lead-Acid (VRLA) Batteries Excluding distributed UFLS and distributed UVLS (see Table 3)		
Protection System Station dc supply used only for non-BES interrupting devices for RAS, non-distributed UFLS systems, or non-distributed UVLS systems is excluded (see Table 1-4(e)).		
Component Attributes	Maximum Maintenance Interval	Maintenance Activities
Protection System Station dc supply with Valve Regulated Lead-Acid (VRLA) batteries not having monitoring attributes of Table 1-4(f).	4 Calendar Months	Verify: <ul style="list-style-type: none"> • Station dc supply voltage Inspect: <ul style="list-style-type: none"> • For unintentional grounds
	6 Calendar Months	Inspect: <ul style="list-style-type: none"> • Condition of all individual units by measuring battery cell/unit internal ohmic values.
	18 Calendar Months	Verify: <ul style="list-style-type: none"> • Float voltage of battery charger • Battery continuity • Battery terminal connection resistance • Battery intercell or unit-to-unit connection resistance Inspect: <ul style="list-style-type: none"> • Physical condition of battery rack

<p align="center">Table 1-4(b)</p> <p align="center">Component Type – Protection System Station dc Supply Using Valve-Regulated Lead-Acid (VRLA) Batteries</p> <p align="center">Excluding distributed UFLS and distributed UVLS (see Table 3)</p> <p align="center">Protection System Station dc supply used only for non-BES interrupting devices for RAS, non-distributed UFLS systems, or non-distributed UVLS systems is excluded (see Table 1-4(e)).</p>		
Component Attributes	Maximum Maintenance Interval	Maintenance Activities
	6 Calendar Months -or- 3 Calendar Years	Verify that the station battery can perform as manufactured by evaluating cell/unit measurements indicative of battery performance (e.g. internal ohmic values or float current) against the station battery baseline. -or- Verify that the station battery can perform as manufactured by conducting a performance or modified performance capacity test of the entire battery bank.

Table 1-4(c) Component Type – Protection System Station dc Supply Using Nickel-Cadmium (NiCad) Batteries Excluding distributed UFLS and distributed UVLS (see Table 3)		
Protection System Station dc supply used only for non-BES interrupting devices for RAS, non-distributed UFLS system, or non-distributed UVLS systems is excluded (see Table 1-4(e)).		
Component Attributes	Maximum Maintenance Interval	Maintenance Activities
Protection System Station dc supply Nickel-Cadmium (NiCad) batteries not having monitoring attributes of Table 1-4(f).	4 Calendar Months	Verify: <ul style="list-style-type: none"> • Station dc supply voltage Inspect: <ul style="list-style-type: none"> • Electrolyte level • For unintentional grounds
	18 Calendar Months	Verify: <ul style="list-style-type: none"> • Float voltage of battery charger • Battery continuity • Battery terminal connection resistance • Battery intercell or unit-to-unit connection resistance Inspect: <ul style="list-style-type: none"> • Cell condition of all individual battery cells. • Physical condition of battery rack

Table 1-4(c) Component Type – Protection System Station dc Supply Using Nickel-Cadmium (NiCad) Batteries Excluding distributed UFLS and distributed UVLS (see Table 3)		
Protection System Station dc supply used only for non-BES interrupting devices for RAS, non-distributed UFLS system, or non-distributed UVLS systems is excluded (see Table 1-4(e)).		
Component Attributes	Maximum Maintenance Interval	Maintenance Activities
	6 Calendar Years	Verify that the station battery can perform as manufactured by conducting a performance or modified performance capacity test of the entire battery bank.

Table 1-4(d) Component Type – Protection System Station dc Supply Using Non Battery Based Energy Storage Excluding distributed UFLS and distributed UVLS (see Table 3)		
Protection System Station dc supply used only for non-BES interrupting devices for RAS, non-distributed UFLS system, or non-distributed UVLS systems is excluded (see Table 1-4(e)).		
Component Attributes	Maximum Maintenance Interval	Maintenance Activities
Any Protection System station dc supply not using a battery and not having monitoring attributes of Table 1-4(f).	4 Calendar Months	Verify: <ul style="list-style-type: none"> • Station dc supply voltage Inspect: <ul style="list-style-type: none"> • For unintentional grounds
	18 Calendar Months	Inspect: Condition of non-battery based dc supply
	6 Calendar Years	Verify that the dc supply can perform as manufactured when ac power is not present.

Table 1-4(e)		
Component Type – Protection System Station dc Supply for non-BES Interrupting Devices for RAS, non-distributed UFLS, and non-distributed UVLS systems		
Component Attributes	Maximum Maintenance Interval	Maintenance Activities
Any Protection System dc supply used for tripping only non-BES interrupting devices as part of a RAS, non-distributed UFLS, or non-distributed UVLS system and not having monitoring attributes of Table 1-4(f).	When control circuits are verified (See Table 1-5)	Verify Station dc supply voltage.

Table 1-4(f) Exclusions for Protection System Station dc Supply Monitoring Devices and Systems		
Component Attributes	Maximum Maintenance Interval	Maintenance Activities
Any station dc supply with high and low voltage monitoring and alarming of the battery charger voltage to detect charger overvoltage and charger failure (See Table 2).	No periodic maintenance specified	No periodic verification of station dc supply voltage is required.
Any battery based station dc supply with electrolyte level monitoring and alarming in every cell (See Table 2).		No periodic inspection of the electrolyte level for each cell is required.
Any station dc supply with unintentional dc ground monitoring and alarming (See Table 2).		No periodic inspection of unintentional dc grounds is required.
Any station dc supply with charger float voltage monitoring and alarming to ensure correct float voltage is being applied on the station dc supply (See Table 2).		No periodic verification of float voltage of battery charger is required.
Any battery based station dc supply with monitoring and alarming of battery string continuity (See Table 2).		No periodic verification of the battery continuity is required.
Any battery based station dc supply with monitoring and alarming of the intercell and/or terminal connection detail resistance of the entire battery (See Table 2).		No periodic verification of the intercell and terminal connection resistance is required.
Any Valve Regulated Lead-Acid (VRLA) or Vented Lead-Acid (VLA) station battery with internal ohmic value or float current monitoring and alarming, and evaluating present values relative to baseline internal ohmic values for every cell/unit (See Table 2).		No periodic evaluation relative to baseline of battery cell/unit measurements indicative of battery performance is required to verify the station battery can perform as manufactured.
Any Valve Regulated Lead-Acid (VRLA) or Vented Lead-Acid (VLA) station battery with monitoring and alarming of each cell/unit internal ohmic value (See Table 2).		No periodic inspection of the condition of all individual units by measuring battery cell/unit internal ohmic values of a station VRLA or Vented Lead-Acid (VLA) battery is required.

Table 1-5 Component Type - Control Circuitry Associated With Protective Functions Excluding distributed UFLS and distributed UVLS (see Table 3), Automatic Reclosing (see Table 4), and Sudden Pressure Relaying (see Table 5) Note: Table requirements apply to all Control Circuitry Components of Protection Systems, and RAS except as noted.		
Component Attributes	Maximum Maintenance Interval	Maintenance Activities
Trip coils or actuators of circuit breakers, interrupting devices, or mitigating devices (regardless of any monitoring of the control circuitry).	6 Calendar Years	Verify that each trip coil is able to operate the circuit breaker, interrupting device, or mitigating device.
Electromechanical lockout devices which are directly in a trip path from the protective relay to the interrupting device trip coil (regardless of any monitoring of the control circuitry).	6 Calendar Years	Verify electrical operation of electromechanical lockout devices.
Unmonitored control circuitry associated with RAS. (See Table 4-2(b) for RAS which include Automatic Reclosing.)	12 Calendar Years	Verify all paths of the control circuits essential for proper operation of the RAS.
Unmonitored control circuitry associated with protective functions inclusive of all auxiliary relays.	12 Calendar Years	Verify all paths of the trip circuits inclusive of all auxiliary relays through the trip coil(s) of the circuit breakers or other interrupting devices.
Control circuitry associated with protective functions and/or RAS whose integrity is monitored and alarmed (See Table 2).	No periodic maintenance specified	None.

Table 2 – Alarming Paths and Monitoring In Tables 1-1 through 1-5, Table 3, Tables 4-1 through 4-3, and Table 5 alarm attributes used to justify extended maximum maintenance intervals and/or reduced maintenance activities are subject to the following maintenance requirements		
Component Attributes	Maximum Maintenance Interval	Maintenance Activities
Any alarm path through which alarms in Tables 1-1 through 1-5, Table 3, Tables 4-1 through 4-3, and Table 5 are conveyed from the alarm origin to the location where corrective action can be initiated, and not having all the attributes of the “Alarm Path with monitoring” category below. Alarms are reported within 24 hours of detection to a location where corrective action can be initiated.	12 Calendar Years	Verify that the alarm path conveys alarm signals to a location where corrective action can be initiated.
Alarm Path with monitoring: The location where corrective action is taken receives an alarm within 24 hours for failure of any portion of the alarming path from the alarm origin to the location where corrective action can be initiated.	No periodic maintenance specified	None.

Table 3 Maintenance Activities and Intervals for distributed UFLS and distributed UVLS Systems		
Component Attributes	Maximum Maintenance Interval	Maintenance Activities
Any unmonitored protective relay not having all the monitoring attributes of a category below.	6 Calendar Years	<p>Verify that settings are as specified.</p> <p>For non-microprocessor relays:</p> <ul style="list-style-type: none"> • Test and, if necessary calibrate. <p>For microprocessor relays:</p> <ul style="list-style-type: none"> • Verify operation of the relay inputs and outputs that are essential to proper functioning of the Protection System. • Verify acceptable measurement of power system input values.
<p>Monitored microprocessor protective relay with the following:</p> <ul style="list-style-type: none"> • Internal self-diagnosis and alarming (See Table 2). • Voltage and/or current waveform sampling three or more times per power cycle, and conversion of samples to numeric values for measurement calculations by microprocessor electronics. <p>Alarming for power supply failure (See Table 2).</p>	12 Calendar Years	<p>Verify:</p> <ul style="list-style-type: none"> • Settings are as specified. • Operation of the relay inputs and outputs that are essential to proper functioning of the Protection System. • Acceptable measurement of power system input values.
<p>Monitored microprocessor protective relay with preceding row attributes and the following:</p> <ul style="list-style-type: none"> • AC measurements are continuously verified by comparison to an independent ac measurement source, with alarming for excessive error (See Table 2). 	12 Calendar Years	<p>Verify only the unmonitored relay inputs and outputs that are essential to proper functioning of the Protection System.</p>

Table 3 Maintenance Activities and Intervals for distributed UFLS and distributed UVLS Systems		
Component Attributes	Maximum Maintenance Interval	Maintenance Activities
<ul style="list-style-type: none"> Some or all binary or status inputs and control outputs are monitored by a process that continuously demonstrates ability to perform as designed, with alarming for failure (See Table 2). Alarming for change of settings (See Table 2).		
Voltage and/or current sensing devices associated with UFLS or UVLS systems.	12 Calendar Years	Verify that current and/or voltage signal values are provided to the protective relays.
Protection System dc supply for tripping non-BES interrupting devices used only for a UFLS or UVLS system.	12 Calendar Years	Verify Protection System dc supply voltage.
Control circuitry between the UFLS or UVLS relays and electromechanical lockout and/or tripping auxiliary devices (excludes non-BES interrupting device trip coils).	12 Calendar Years	Verify the path from the relay to the lockout and/or tripping auxiliary relay (including essential supervisory logic).
Electromechanical lockout and/or tripping auxiliary devices associated only with UFLS or UVLS systems (excludes non-BES interrupting device trip coils).	12 Calendar Years	Verify electrical operation of electromechanical lockout and/or tripping auxiliary devices.
Control circuitry between the electromechanical lockout and/or tripping auxiliary devices and the non-BES interrupting devices in UFLS or UVLS systems, or between UFLS or UVLS relays (with no interposing electromechanical lockout or auxiliary device) and the non-BES interrupting devices (excludes non-BES interrupting device trip coils).	No periodic maintenance specified	None.
Trip coils of non-BES interrupting devices in UFLS or UVLS systems.	No periodic maintenance specified	None.

<p style="text-align: center;">Table 4-1 Maintenance Activities and Intervals for Automatic Reclosing Components Component Type – Reclosing and Supervisory Relay</p> <p>Note: In cases where Components of Automatic Reclosing are common to Components listed in Table 1-1 through 1-5, the Components only need to be tested once during a distinct maintenance interval.</p>		
Component Attributes	Maximum Maintenance Interval	Maintenance Activities
<p>Any unmonitored reclosing relay or supervisory relay not having all the monitoring attributes of a category below.</p>	<p>6 Calendar Years</p>	<p>Verify that settings are as specified.</p> <p>For non-microprocessor reclosing or supervisory relays:</p> <ul style="list-style-type: none"> • Test and, if necessary calibrate <p>For microprocessor reclosing or supervisory relays:</p> <ul style="list-style-type: none"> • Verify operation of the relay inputs and outputs that are essential to proper functioning of the Automatic Reclosing. <p>For microprocessor supervisory relays:</p> <ul style="list-style-type: none"> • Verify acceptable measurement of power system input values.
<ul style="list-style-type: none"> • Monitored microprocessor reclosing relay or supervisory relay with the following: Internal self-diagnosis and alarming (See Table 2). • Alarming for power supply failure (See Table 2). <p>For supervisory relay:</p> <ul style="list-style-type: none"> • Voltage waveform sampling three or more times per power cycle, and conversion of samples to numeric values for measurement calculations by microprocessor electronics. 	<p>12 Calendar Years</p>	<p>Verify:</p> <ul style="list-style-type: none"> • Settings are as specified. • Operation of the relay inputs and outputs that are essential to proper functioning of the Automatic Reclosing. <p>For supervisory relays:</p> <ul style="list-style-type: none"> • Verify acceptable measurement of power system input values.

Table 4-1 Maintenance Activities and Intervals for Automatic Reclosing Components Component Type – Reclosing and Supervisory Relay		
Note: In cases where Components of Automatic Reclosing are common to Components listed in Table 1-1 through 1-5, the Components only need to be tested once during a distinct maintenance interval.		
Component Attributes	Maximum Maintenance Interval	Maintenance Activities
Monitored microprocessor reclosing relay or supervisory relay with preceding row attributes and the following: <ul style="list-style-type: none"> Some or all binary or status inputs and control outputs are monitored by a process that continuously demonstrates ability to perform as designed, with alarming for failure (See Table 2). Alarming for change of settings (See Table 2). For supervisory relay: <ul style="list-style-type: none"> Ac measurements are continuously verified by comparison to an independent ac measurement source, with alarming for excessive error (See Table 2). 	12 Calendar Years	Verify only the unmonitored relay inputs and outputs that are essential to proper functioning of the Automatic Reclosing.

<p align="center">Table 4-2(a) Maintenance Activities and Intervals for Automatic Reclosing Components Component Type – Control Circuitry Associated with Reclosing and Supervisory Relays that are NOT an Integral Part of an RAS Note: In cases where Components of Automatic Reclosing are common to Components listed in Table 1-5, the Components only need to be tested once during a distinct maintenance interval.</p>		
Component Attributes	Maximum Maintenance Interval	Maintenance Activities
Unmonitored Control circuitry associated with Automatic Reclosing that is not an integral part of an RAS.	12 Calendar Years	Verify that Automatic Reclosing, upon initiation, does not issue a premature closing command to the close circuitry.
Control circuitry associated with Automatic Reclosing that is not part of an RAS and is monitored and alarmed for conditions that would result in a premature closing command. (See Table 2)	No periodic maintenance specified	None.

Table 4-2(b)

Maintenance Activities and Intervals for Automatic Reclosing Components

Component Type – Control Circuitry Associated with Reclosing and Supervisory Relays that ARE an Integral Part of an RAS

Note: In cases where Components of Automatic Reclosing are common to Components listed in Table 1-5, the Components only need to be tested once during a distinct maintenance interval.

Component Attributes	Maximum Maintenance Interval	Maintenance Activities
Close coils or actuators of circuit breakers or similar devices that are used in conjunction with Automatic Reclosing as part of an RAS (regardless of any monitoring of the control circuitry).	6 Calendar Years	Verify that each close coil or actuator is able to operate the circuit breaker or mitigating device.
Unmonitored close control circuitry associated with Automatic Reclosing used as an integral part of an RAS.	12 Calendar Years	Verify all paths of the control circuits associated with Automatic Reclosing that are essential for proper operation of the RAS.
Control circuitry associated with Automatic Reclosing that is an integral part of an RAS whose integrity is monitored and alarmed. (See Table 2)	No periodic maintenance specified	None.

Table 4-3 Maintenance Activities and Intervals for Automatic Reclosing Components Component Type – Voltage Sensing Devices Associated with Supervisory Relays Note: In cases where Components of Automatic Reclosing are common to Components listed in Table 1-3, the Components only need to be tested once during a distinct maintenance interval.		
Component Attributes	Maximum Maintenance Interval	Maintenance Activities
Any voltage sensing devices not having monitoring attributes of the category below.	12 Calendar Years	Verify that voltage signal values are provided to the supervisory relays.
Voltage sensing devices that are connected to microprocessor supervisory relays with ac measurements that are continuously verified by comparison of sensing input value, as measured by the microprocessor relay, to an independent ac measurement source, with alarming for unacceptable error or failure. (See Table 2)	No periodic maintenance specified	None.

<p style="text-align: center;">Table 5 Maintenance Activities and Intervals for Sudden Pressure Relaying</p>		
<p style="text-align: center;">Note: In cases where Components of Sudden Pressure Relaying are common to Components listed in Table 1-5, the Components only need to be tested once during a distinct maintenance interval.</p>		
Component Attributes	Maximum Maintenance Interval	Maintenance Activities
Any fault pressure relay.	6 Calendar Years	Verify the pressure or flow sensing mechanism is operable.
Electromechanical lockout devices which are directly in a trip path from the fault pressure relay to the interrupting device trip coil (regardless of any monitoring of the control circuitry).	6 Calendar Years	Verify electrical operation of electromechanical lockout devices.
Unmonitored control circuitry associated with Sudden Pressure Relaying.	12 Calendar Years	Verify all paths of the trip circuits inclusive of all auxiliary relays through the trip coil(s) of the circuit breakers or other interrupting devices.
Control circuitry associated with Sudden Pressure Relaying whose integrity is monitored and alarmed (See Table 2).	No periodic maintenance specified	None.

PRC-005 — Attachment A

Criteria for a Performance-Based Protection System Maintenance Program

Purpose: To establish a technical basis for initial and continued use of a performance-based Protection System Maintenance Program (PSMP).

To establish the technical justification for the initial use of a performance-based PSMP:

1. Develop a list with a description of Components included in each designated Segment, with a minimum Segment population of 60 Components.
2. Maintain the Components in each Segment according to the time-based maximum allowable intervals established in Tables 1-1 through 1-5, Table 3, Tables 4-1 through 4-3, and Table 5 until results of maintenance activities for the Segment are available for a minimum of 30 individual Components of the Segment.
3. Document the maintenance program activities and results for each Segment, including maintenance dates and Countable Events for each included Component.
4. Analyze the maintenance program activities and results for each Segment to determine the overall performance of the Segment and develop maintenance intervals.
5. Determine the maximum allowable maintenance interval for each Segment such that the Segment experiences Countable Events on no more than 4% of the Components within the Segment, for the greater of either the last 30 Components maintained or all Components maintained in the previous year.

To maintain the technical justification for the ongoing use of a performance-based PSMP:

1. At least annually, update the list of Components and Segments and/or description if any changes occur within the Segment.
2. Perform maintenance on the greater of 5% of the Components (addressed in the performance based PSMP) in each Segment or 3 individual Components within the Segment in each year.
3. For the prior year, analyze the maintenance program activities and results for each Segment to determine the overall performance of the Segment.
4. Using the prior year's data, determine the maximum allowable maintenance interval for each Segment such that the Segment experiences Countable Events on no more than 4% of the Components within the Segment, for the greater of either the last 30 Components maintained or all Components maintained in the previous year.

If the Components in a Segment maintained through a performance-based PSMP experience 4% or more Countable Events, develop, document, and implement an action plan to reduce the Countable Events to less than 4% of the Segment population within 3 years.

Rationale:

During development of this standard, text boxes were embedded within the standard to explain the rationale for various parts of the standard. Upon BOT approval, the text from the rationale text boxes was moved to this section.

Standard Development Timeline

This section is maintained by the drafting team during the development of the standard and will be removed when the standard becomes effective.

Development Steps Completed

1. SAR posted for comment March 12 – April 10, 2015.
2. Revised SAR reposted with revisions for comment June 11 – July 10, 2015

Description of Current Draft

This version of PRC-005 was posted for a 45-day concurrent comment and ballot period to address directives from [FERC Order No. 803](#), addressing Automatic Reclosing. Specifically, supervisory relays, associated voltage sensing devices, and associated control circuitry were added.

Anticipated Actions	Anticipated Dates
45-day Formal Comment Period with Concurrent Ballot	July 2015 – September 2015
Final ballot	October 2015
BOT adoption	November 2015

Definitions of Terms Used in Standard

This section includes all newly defined or revised terms used in the proposed standard. Terms already defined in the Reliability Standards Glossary of Terms (Glossary) are not repeated here. New or revised definitions listed below become approved when the proposed standard is approved. When the standard becomes effective, this defined term will be removed from the individual standard and added to the Glossary.

See Section 6 of the Standard

A. Introduction

1. **Title:** Protection System, Automatic Reclosing, and Sudden Pressure Relaying Maintenance
2. **Number:** PRC-005-6
3. **Purpose:** To document and implement programs for the maintenance of all Protection Systems, Automatic Reclosing, and Sudden Pressure Relaying affecting the reliability of the Bulk Electric System (BES) so that they are kept in working order.
4. **Applicability:**
 - 4.1. **Functional Entities:**
 - 4.1.1 Transmission Owner
 - 4.1.2 Generator Owner
 - 4.1.3 Distribution Provider
 - 4.2. **Facilities:**
 - 4.2.1 Protection Systems and Sudden Pressure Relaying that are installed for the purpose of detecting Faults on BES Elements (lines, buses, transformers, etc.)
 - 4.2.2 Protection Systems used for underfrequency load-shedding systems installed per ERO underfrequency load-shedding requirements.
 - 4.2.3 Protection Systems used for undervoltage load-shedding systems installed to prevent system voltage collapse or voltage instability for BES reliability.
 - 4.2.4 Protection Systems installed as a Remedial Action Scheme (RAS) for BES reliability.
 - 4.2.5 Protection Systems and Sudden Pressure Relaying for generator Facilities that are part of the BES, except for generators identified through Inclusion I4 of the BES definition, including:
 - 4.2.5.1 Protection Systems that act to trip the generator either directly or via lockout or auxiliary tripping relays.
 - 4.2.5.2 Protection Systems and Sudden Pressure Relaying for generator step-up transformers for generators that are part of the BES.
 - 4.2.5.3 Protection Systems and Sudden Pressure Relaying for station service or excitation transformers connected to the generator bus of generators which are part of the BES, that act to trip the generator either directly or via lockout or tripping auxiliary relays.

4.2.6 Protection Systems and Sudden Pressure Relaying for the following BES generator Facilities for dispersed power producing resources identified through Inclusion I4 of the BES definition:

4.2.6.1 Protection Systems and Sudden Pressure Relaying for Facilities used in aggregating dispersed BES generation from the point where those resources aggregate to greater than 75 MVA to a common point of connection at 100kV or above.

4.2.7 Automatic Reclosing¹, including:

4.2.7.1 Automatic Reclosing applied on the terminals of Elements connected to the BES bus located at generating plant substations where the total installed gross generating plant capacity is greater than the gross capacity of the largest BES generating unit within the Balancing Authority Area or, if a member of a Reserve Sharing Group, the largest generating unit within the Reserve Sharing Group.²

4.2.7.2 Automatic Reclosing applied on the terminals of all BES Elements at substations one bus away from generating plants specified in Section 4.2.7.1 when the substation is less than 10 circuit-miles from the generating plant substation.

4.2.7.3 Automatic Reclosing applied as an integral part of an RAS specified in Section 4.2.4.

5. Effective Date: See the Implementation Plan for this standard.

6. Definitions Used in this Standard:

¹ Automatic Reclosing addressed in Section 4.2.7.1 and 4.2.7.2 may be excluded if the equipment owner can demonstrate that a close-in three-phase fault present for twice the normal clearing time (capturing a minimum trip-close-trip time delay) does not result in a total loss of gross generation in the Interconnection exceeding the gross capacity of the largest relevant BES generating unit where the Automatic Reclosing is applied.

² The largest BES generating unit within the Balancing Authority Area or the largest generating unit within the Reserve Sharing Group, as applicable, is subject to change. As a result of such a change, the Automatic Reclosing Components subject to the standard could change effective on the date of such change.

Automatic Reclosing – Includes the following Components:

- Reclosing relay
- Supervisory relay(s) or function(s) – relay(s) or function(s) that perform voltage and/or sync check functions that enable or disable operation of the reclosing relay
- Voltage sensing devices associated with the supervisory relay(s) or function(s)
- Control circuitry associated with the reclosing relay or supervisory relay(s) or function(s)

Rationale for revisions to Automatic Reclosing: To address directives from FERC Order No. 803 addressing Automatic Reclosing, the definition for Automatic Reclosing was revised to add supervisory relays, the associated voltage sensing devices, and the associated control circuitry.

Sudden Pressure Relaying – A system that trips an interrupting device(s) to isolate the equipment it is monitoring and includes the following Components:

- Fault pressure relay – a mechanical relay or device that detects rapid changes in gas pressure, oil pressure, or oil flow that are indicative of Faults within liquid-filled, wire-wound equipment
- Control circuitry associated with a fault pressure relay

Unresolved Maintenance Issue – A deficiency identified during a maintenance activity that causes the Component to not meet the intended performance, cannot be corrected during the maintenance interval, and requires follow-up corrective action.

Segment – Components of a consistent design standard, or a particular model or type from a single manufacturer that typically share other common elements. Consistent performance is expected across the entire population of a Segment. A Segment must contain at least sixty (60) individual Components.

Component Type –

- Any one of the five specific elements of a Protection System-~~r~~
- Any one of the four specific elements of Automatic Reclosing-~~r~~
- Any one of the two specific elements of Sudden Pressure Relaying-~~r~~

Rationale for revisions to Component Type: With the revision of the definition of Automatic Reclosing, there are four specific elements of this definition, rather than two as stated in the prior version.

Component – Any individual discrete piece of equipment included in a Protection System, Automatic Reclosing, or Sudden Pressure Relaying.

Countable Event – A failure of a Component requiring repair or replacement, any condition discovered during the maintenance activities in Tables 1-1 through 1-5, Table 3, Tables 4-1 through 4-3, and Table 5, which requires corrective action or a Protection System Misoperation attributed to hardware failure or calibration failure. Misoperations due to product design errors, software errors, relay settings different from specified settings, Protection System Component, Automatic Reclosing, or Sudden Pressure Relaying configuration or application errors are not included in Countable Events.

B. Requirements and Measures

- R1.** Each Transmission Owner, Generator Owner, and Distribution Provider shall establish a Protection System Maintenance Program (PSMP) for its Protection Systems, Automatic Reclosing, and Sudden Pressure Relaying identified in Section 4.2, Facilities. *[Violation Risk Factor: Medium] [Time Horizon: Operations Planning]*

The PSMP shall:

- 1.1.** Identify which maintenance method (time-based, performance-based per PRC-005 Attachment A, or a combination) is used to address each Protection System, Automatic Reclosing, and Sudden Pressure Relaying Component Type. All batteries associated with the station ~~DCdc~~ supply Component Type of a Protection System shall be included in a time-based program as described in Table 1-4 and Table 3.
- 1.2.** Include the applicable monitored Component attributes applied to each Protection System, Automatic Reclosing, and Sudden Pressure Relaying Component Type consistent with the maintenance intervals specified in Tables 1-1 through 1-5, Table 2, Table 3, Table 4-1 through 4-3, and Table 5 where monitoring is used to extend the maintenance intervals beyond those specified for unmonitored Protection System, Automatic Reclosing, and Sudden Pressure Relaying Components.

- M1.** Each Transmission Owner, Generator Owner and Distribution Provider shall have a documented PSMP in accordance with Requirement R1.

For each Protection System, Automatic Reclosing, and Sudden Pressure Relaying Component Type, the documentation shall include the type of maintenance method applied (time-based, performance-based, or a combination of these maintenance methods), and shall include all batteries associated with the station ~~DCdc~~ supply Component Types in a time-based program as described in Table 1-4 and Table 3. (Part 1.1)

For Component Types that use monitoring to extend the maintenance intervals, the responsible entity(s) shall have evidence for each Protection System, Automatic Reclosing, and Sudden Pressure Relaying Component Type (such as manufacturer's specifications or engineering drawings) of the appropriate monitored Component

attributes as specified in Tables 1-1 through 1-5, Table 2, Table 3, Table 4-1 through 4-3, and Table 5. (Part 1.2)

- R2.** Each Transmission Owner, Generator Owner, and Distribution Provider that uses performance-based maintenance intervals in its PSMP shall follow the procedure established in PRC-005 Attachment A to establish and maintain its performance-based intervals. *[Violation Risk Factor: Medium] [Time Horizon: Operations Planning]*
- M2.** Each Transmission Owner, Generator Owner, and Distribution Provider that uses performance-based maintenance intervals shall have evidence that its current performance-based maintenance program(s) is in accordance with Requirement R2, which may include, but is not limited to, Component lists, dated maintenance records, and dated analysis records and results.
- R3.** Each Transmission Owner, Generator Owner, and Distribution Provider that utilizes time-based maintenance program(s) shall maintain its Protection System, Automatic Reclosing, and Sudden Pressure Relaying Components that are included within the time-based maintenance program in accordance with the minimum maintenance activities and maximum maintenance intervals prescribed within Tables 1-1 through 1-5, Table 2, Table 3, Table 4-1 through 4-3, and Table 5. *[Violation Risk Factor: High] [Time Horizon: Operations Planning]*
- M3.** Each Transmission Owner, Generator Owner, and Distribution Provider that utilizes time-based maintenance program(s) shall have evidence that it has maintained its Protection System, Automatic Reclosing, and Sudden Pressure Relaying Components included within its time-based program in accordance with Requirement R3. The evidence may include, but is not limited to, dated maintenance records, dated maintenance summaries, dated check-off lists, dated inspection records, or dated work orders.
- R4.** Each Transmission Owner, Generator Owner, and Distribution Provider that utilizes performance-based maintenance program(s) in accordance with Requirement R2 shall implement and follow its PSMP for its Protection System, Automatic Reclosing, and Sudden Pressure Relaying Components that are included within the performance-based program(s). *[Violation Risk Factor: High] [Time Horizon: Operations Planning]*
- M4.** Each Transmission Owner, Generator Owner, and Distribution Provider that utilizes performance-based maintenance intervals in accordance with Requirement R2 shall have evidence that it has implemented the PSMP for the Protection System, Automatic Reclosing, and Sudden Pressure Relaying Components included in its performance-based program in accordance with Requirement R4. The evidence may include, but is not limited to, dated maintenance records, dated maintenance summaries, dated check-off lists, dated inspection records, or dated work orders.
- R5.** Each Transmission Owner, Generator Owner, and Distribution Provider shall demonstrate efforts to correct identified Unresolved Maintenance Issues. *[Violation Risk Factor: Medium] [Time Horizon: Operations Planning]*

- M5.** Each Transmission Owner, Generator Owner, and Distribution Provider shall have evidence that it has undertaken efforts to correct identified Unresolved Maintenance Issues in accordance with Requirement R5. The evidence may include, but is not limited to, work orders, replacement Component orders, invoices, project schedules with completed milestones, return material authorizations (RMAs) or purchase orders.

C. Compliance

1. Compliance Monitoring Process

1.1. Compliance Enforcement Authority

As defined in the NERC Rules of Procedure, “Compliance Enforcement Authority” means NERC or the Regional Entity in their respective roles of monitoring and enforcing compliance with the NERC Reliability Standards.

1.2. Evidence Retention

The following evidence retention periods identify the period of time an entity is required to retain specific evidence to demonstrate compliance. For instances where the evidence retention period specified below is shorter than the time since the last audit, the Compliance Enforcement Authority may ask an entity to provide other evidence to show that it was compliant for the full time period since the last audit.

The Transmission Owner, Generator Owner, and Distribution Provider shall each keep data or evidence to show compliance as identified below unless directed by its Compliance Enforcement Authority to retain specific evidence for a longer period of time as part of an investigation.

For Requirement R1, the Transmission Owner, Generator Owner, and Distribution Provider shall each keep its current dated PSMP, as well as any superseded versions since the preceding compliance audit, including the documentation that specifies the type of maintenance program applied for each Protection System, Automatic Reclosing, or Sudden Pressure Relaying Component Type.

For Requirement R2, Requirement R3, and Requirement R4, in cases where the interval of the maintenance activity is longer than the audit cycle, the Transmission Owner, Generator Owner, and Distribution Provider shall each keep documentation of the most recent performance of that maintenance activity for the Protection System, Automatic Reclosing, or Sudden Pressure Relaying Component. In cases where the interval of the maintenance activity is shorter than the audit cycle, documentation of all performances (in accordance with the tables) of that maintenance activity for the Protection System,

Automatic Reclosing, or Sudden Pressure Relaying Component since the previous scheduled audit date shall be retained.

For Requirement R5 the Transmission Owner, Generator Owner, and Distribution Provider shall each keep documentation of Unresolved Maintenance Issues identified by the entity since the last audit, including all that were resolved since the last audit.

1.3. Compliance Monitoring and Assessment Processes:

Compliance Audits

Self-Certifications

Spot Checking

Compliance Investigations

Self-Reporting

Complaints

1.4. Additional Compliance Information

None

Table of Compliance Elements

Requirement Number	Lower VSL	Moderate VSL	High VSL	Severe VSL
R1	The entity's PSMP failed to specify whether one Component Type is being addressed by time-based or performance-based maintenance, or a combination of both (Part 1.1).	The entity's PSMP failed to specify whether two Component Types are being addressed by time-based or performance-based maintenance, or a combination of both (Part 1.1).	The entity's PSMP failed to specify whether three Component Types are being addressed by time-based or performance-based maintenance, or a combination of both. (Part 1.1). OR The entity's PSMP failed to include the applicable monitoring attributes applied to each Component Type consistent with the maintenance intervals specified in Tables 1-1 through 1-5, Table 2, Table 3, Tables 4-1 through 4-3, and Table 5 where monitoring is used to extend the maintenance intervals beyond those specified for unmonitored Components (Part 1.2).	The entity failed to establish a PSMP. OR The entity's PSMP failed to specify whether four or more Component Types are being addressed by time-based or performance-based maintenance, or a combination of both (Part 1.1). OR The entity's PSMP failed to include applicable station batteries in a time-based program (Part 1.1).
R2	The entity uses performance-based maintenance intervals in its PSMP but failed to reduce Countable Events to no more than 4% within three years.	NA	The entity uses performance-based maintenance intervals in its PSMP but failed to reduce Countable Events to no more than 4% within four years.	The entity uses performance-based maintenance intervals in its PSMP but: 1) Failed to establish the technical justification described within Requirement R2 for the initial use of the performance-based PSMP OR 2) Failed to reduce Countable Events to no more than 4% within five years OR

Requirement Number	Lower VSL	Moderate VSL	High VSL	Severe VSL
				3) Maintained a Segment with less than 60 Components OR 4) Failed to: <ul style="list-style-type: none"> • Annually update the list of Components, OR • Annually perform maintenance on the greater of 5% of the Segment population or 3 Components, OR • Annually analyze the program activities and results for each Segment.
R3	For Components included within a time-based maintenance program, the entity failed to maintain 5% or less of the total Components included within a specific Component Type in accordance with the minimum maintenance activities and maximum maintenance intervals prescribed within Tables 1-1 through 1-5, Table 2, Table 3, Tables 4-1 through 4-3, and Table 5.	For Components included within a time-based maintenance program, the entity failed to maintain more than 5% but 10% or less of the total Components included within a specific Component Type in accordance with the minimum maintenance activities and maximum maintenance intervals prescribed within Tables 1-1 through 1-5, Table 2, Table 3, Tables 4-1 through 4-3, and Table 5.	For Components included within a time-based maintenance program, the entity failed to maintain more than 10% but 15% or less of the total Components included within a specific Component Type in accordance with the minimum maintenance activities and maximum maintenance intervals prescribed within Tables 1-1 through 1-5, Table 2, Table 3, Tables 4-1 through 4-3, and Table 5.	For Components included within a time-based maintenance program, the entity failed to maintain more than 15% of the total Components included within a specific Component Type in accordance with the minimum maintenance activities and maximum maintenance intervals prescribed within Tables 1-1 through 1-5, Table 2, Table 3, Tables 4-1 through 4-3, and Table 5.

Requirement Number	Lower VSL	Moderate VSL	High VSL	Severe VSL
R4	For Components included within a performance-based maintenance program, the entity failed to maintain 5% or less of the annual scheduled maintenance for a specific Component Type in accordance with their performance-based PSMP.	For Components included within a performance-based maintenance program, the entity failed to maintain more than 5% but 10% or less of the annual scheduled maintenance for a specific Component Type in accordance with their performance-based PSMP.	For Components included within a performance-based maintenance program, the entity failed to maintain more than 10% but 15% or less of the annual scheduled maintenance for a specific Component Type in accordance with their performance-based PSMP.	For Components included within a performance-based maintenance program, the entity failed to maintain more than 15% of the annual scheduled maintenance for a specific Component Type in accordance with their performance-based PSMP.
R5	The entity failed to undertake efforts to correct 5 or fewer identified Unresolved Maintenance Issues.	The entity failed to undertake efforts to correct greater than 5 but less than or equal to 10 identified Unresolved Maintenance Issues.	The entity failed to undertake efforts to correct greater than 10 but less than or equal to 15 identified Unresolved Maintenance Issues.	The entity failed to undertake efforts to correct greater than 15 identified Unresolved Maintenance Issues.

D. Regional Variances

None.

E. Interpretations

None.

Supplemental Reference Documents

The following documents present a detailed discussion about determination of maintenance intervals and other useful information regarding establishment of a maintenance program.

1. *Supplementary Reference and FAQ - PRC-005-6 Protection System Maintenance*, Protection System Maintenance and Testing Standard Drafting Team (~~July~~^{April} 2015)
2. *Considerations for Maintenance and Testing of Auto-reclosing Schemes*, NERC System Analysis and Modeling Subcommittee, and NERC System Protection and Control Subcommittee (November 2012)
3. *Sudden Pressure Relays and Other Devices that Respond to Non-Electrical Quantities – SPCS Input for Standard Development in Response to FERC Order No. 758*, NERC System Protection and Control Subcommittee (December 2013)
4. *Sudden Pressure Relays and Other Devices that Respond to Non-Electrical Quantities – Supplemental Information to Support Project 2007-17.3: Protection System Maintenance and Testing* (October 31, 2014)

Version History

Version	Date	Action	Change Tracking
0	February 8, 2005	Adopted by NERC Board of Trustees	New.
1	February 7, 2006	Adopted by NERC Board of Trustees	<ol style="list-style-type: none"> 1. Changed incorrect use of certain hyphens (-) to “en dash” (–) and “em dash (—).” 2. Added “periods” to items where appropriate. Changed “Timeframe” to “Time Frame” in item D, 1.2.
1a	February 17, 2011	Adopted by NERC Board of Trustees	Added Appendix 1 - Interpretation regarding applicability of standard to protection of radially connected transformers developed in Project 2009-17.

Version	Date	Action	Change Tracking
1b	November 5, 2009	Adopted by NERC Board of Trustees	Interpretation of R1, R1.1, and R1.2 developed by Project 2009-10.
1b	February 3, 2012	FERC Order approving revised definition of “Protection System”	Per footnote 8 of FERC’s order, the definition of “Protection System” supersedes interpretation “b” of PRC-005-1b upon the effective date of the modified definition (i.e., April 1, 2013). <i>See N. Amer. Elec. Reliability Corp., 138 FERC ¶ 61,095 (February 3, 2012).</i>
1.1b	May 9, 2012	Adopted by NERC Board of Trustees	Errata change developed by Project 2010-07, clarified inclusion of generator interconnection Facility in Generator Owner’s responsibility.
2	November 7, 2012	Adopted by NERC Board of Trustees	Project 2007-17 - Complete revision, absorbing maintenance requirements from PRC-005-1.1b, PRC-008-0, PRC-011-0, PRC-017-0.
2	October 17, 2013	Approved by NERC Standards Committee	Errata Change: The Standards Committee approved an errata change to the implementation plan for PRC-005-2 to add the phrase “or as otherwise made effective pursuant to the laws applicable to such ERO governmental authorities;” to the second sentence under the “Retirement of Existing Standards” section. (no change to standard version number)
2	March 7, 2014	Adopted by NERC Board of Trustees	Modified R1 VSL in response to FERC directive (no change to standard version number).
2(i)	November 13, 2014	Adopted by NERC Board of Trustees	Applicability section revised by Project 2014-01 to clarify application of Requirements to BES dispersed power producing resources.

Version	Date	Action	Change Tracking
2(ii)	November 13, 2014	Adopted by NERC Board of Trustees	Replaced references to Special Protection System and SPS with Remedial Action Scheme and RAS.
3	November 7, 2013	Adopted by the NERC Board of Trustees	Revised to address the FERC directive in Order No. 758 to include Automatic Reclosing in maintenance programs.
3	February 12, 2014	Approved by NERC Standards Committee	Errata Change: The Standards Committee approved errata changes to correct capitalization of certain defined terms within the definitions of “Unresolved Maintenance Issue” and “Protection System Maintenance Program”. The changes will be reflected in the definitions section of PRC-005-3 for “Unresolved Maintenance Issue” and in the NERC Glossary of Terms for “Protection System Maintenance Program”. (no change to standard version number)
3	March 7, 2014	Adopted by NERC Board of Trustees	Modified R1 VSL in response to FERC directive (no change to standard version number).
3(i)	November 13, 2014	Adopted by NERC Board of Trustees	Applicability section revised by Project 2014-01 to clarify application of Requirements to BES dispersed power producing resources.
3(ii)	November 13, 2014	Adopted by NERC Board of Trustees	Replaced references to Special Protection System and SPS with Remedial Action Scheme and RAS.
4	November 13, 2014	Adopted by NERC Board of Trustees	Added Sudden Pressure Relaying in response to FERC Order No. 758.

Version	Date	Action	Change Tracking
5	TBD May 7, 2015	<u>Adopted by NERC Board of Trustees</u>	Applicability section revised by Project 2014-01 to clarify application of Requirements to BES dispersed power producing resources.
6	TBD		Revised to add supervisory relays, <u>the voltage sensing devices, and the associated control circuitry</u> to Automatic Reclosing in accordance with the directives in FERC Order 803.

Table 1-1 Component Type - Protective Relay Excluding distributed UFLS and distributed UVLS (see Table 3)		
Component Attributes	Maximum Maintenance Interval ³	Maintenance Activities
Any unmonitored protective relay not having all the monitoring attributes of a category below.	6 Calendar Years	For all unmonitored relays: <ul style="list-style-type: none"> • Verify that settings are as specified For non-microprocessor relays: <ul style="list-style-type: none"> • Test and, if necessary calibrate For microprocessor relays: <ul style="list-style-type: none"> • Verify operation of the relay inputs and outputs that are essential to proper functioning of the Protection System. • Verify acceptable measurement of power system input values.
Monitored microprocessor protective relay with the following: <ul style="list-style-type: none"> • Internal self-diagnosis and alarming (see Table 2). • Voltage and/or current waveform sampling three or more times per power cycle, and conversion of samples to numeric values for measurement calculations by microprocessor electronics. • Alarming for power supply failure (see Table 2). 	12 Calendar Years	Verify: <ul style="list-style-type: none"> • Settings are as specified. • Operation of the relay inputs and outputs that are essential to proper functioning of the Protection System. • Acceptable measurement of power system input values.

³ For the tables in this standard, a calendar year starts on the first day of a new year (January 1) after a maintenance activity has been completed. For the tables in this standard, a calendar month starts on the first day of the first month after a maintenance activity has been completed.

Table 1-1 Component Type - Protective Relay Excluding distributed UFLS and distributed UVLS (see Table 3)		
Component Attributes	Maximum Maintenance Interval ³	Maintenance Activities
Monitored microprocessor protective relay with preceding row attributes and the following: <ul style="list-style-type: none"> • Ac measurements are continuously verified by comparison to an independent A_{Cac} measurement source, with alarming for excessive error (See Table 2). • Some or all binary or status inputs and control outputs are monitored by a process that continuously demonstrates ability to perform as designed, with alarming for failure (See Table 2). • Alarming for change of settings (See Table 2). 	12 Calendar Years	Verify only the unmonitored relay inputs and outputs that are essential to proper functioning of the Protection System.

Table 1-2 Component Type - Communications Systems Excluding distributed UFLS and distributed UVLS (see Table 3)		
Component Attributes	Maximum Maintenance Interval	Maintenance Activities
Any unmonitored communications system necessary for correct operation of protective functions, and not having all the monitoring attributes of a category below.	4 Calendar Months	Verify that the communications system is functional.
	6 Calendar Years	Verify that the communications system meets performance criteria pertinent to the communications technology applied (e.g. signal level, reflected power, or data error rate). Verify operation of communications system inputs and outputs that are essential to proper functioning of the Protection System.
Any communications system with continuous monitoring or periodic automated testing for the presence of the channel function, and alarming for loss of function (See Table 2).	12 Calendar Years	Verify that the communications system meets performance criteria pertinent to the communications technology applied (e.g. signal level, reflected power, or data error rate). Verify operation of communications system inputs and outputs that are essential to proper functioning of the Protection System.
Any communications system with all of the following: <ul style="list-style-type: none"> • Continuous monitoring or periodic automated testing for the performance of the channel using criteria pertinent to the communications technology applied (e.g. signal level, reflected power, or data error rate, and alarming for excessive performance degradation). (See Table 2) • Some or all binary or status inputs and control outputs are monitored by a process that continuously demonstrates ability to perform as designed, with alarming for failure (See Table 2). 	12 Calendar Years	Verify only the unmonitored communications system inputs and outputs that are essential to proper functioning of the Protection System

Table 1-3 Component Type - Voltage and Current Sensing Devices Providing Inputs to Protective Relays Excluding distributed UFLS and distributed UVLS (see Table 3)		
Component Attributes	Maximum Maintenance Interval	Maintenance Activities
Any voltage and current sensing devices not having monitoring attributes of the category below.	12 Calendar Years	Verify that current and voltage signal values are provided to the protective relays.
Voltage and Current Sensing devices connected to microprocessor relays with <u>acAC</u> measurements that are continuously verified by comparison of sensing input value, as measured by the microprocessor relay, to an independent <u>acAC</u> measurement source, with alarming for unacceptable error or failure (see Table 2).	No periodic maintenance specified	None.

Table 1-4(a) Component Type – Protection System Station dcDC Supply Using Vented Lead-Acid (VLA) Batteries Excluding distributed UFLS and distributed UVLS (see Table 3)		
Protection System Station dcDC supply used only for non-BES interrupting devices for RAS, non-distributed UFLS systems, or non-distributed UVLS systems is excluded (see Table 1-4(e)).		
Component Attributes	Maximum Maintenance Interval	Maintenance Activities
Protection System Station dcDC supply using Vented Lead-Acid (VLA) batteries not having monitoring attributes of Table 1-4(f).	4 Calendar Months	Verify: <ul style="list-style-type: none"> • Station dcDC supply voltage Inspect: <ul style="list-style-type: none"> • Electrolyte level • For unintentional grounds
	18 Calendar Months	Verify: <ul style="list-style-type: none"> • Float voltage of battery charger • Battery continuity • Battery terminal connection resistance • Battery intercell or unit-to-unit connection resistance Inspect: <ul style="list-style-type: none"> • Cell condition of all individual battery cells where cells are visible – or measure battery cell/unit internal ohmic values where the cells are not visible • Physical condition of battery rack

Table 1-4(a)

Component Type – Protection System Station ~~dcDC~~ Supply Using Vented Lead-Acid (VLA) Batteries
 Excluding distributed UFLS and distributed UVLS (see Table 3)

Protection System Station ~~dcDC~~ supply used only for non-BES interrupting devices for RAS, non-distributed UFLS systems, or non-distributed UVLS systems is excluded (see Table 1-4(e)).

Component Attributes	Maximum Maintenance Interval	Maintenance Activities
	18 Calendar Months -or- 6 Calendar Years	Verify that the station battery can perform as manufactured by evaluating cell/unit measurements indicative of battery performance (e.g. internal ohmic values or float current) against the station battery baseline. -or- Verify that the station battery can perform as manufactured by conducting a performance or modified performance capacity test of the entire battery bank.

Table 1-4(b) Component Type – Protection System Station DCdc Supply Using Valve-Regulated Lead-Acid (VRLA) Batteries Excluding distributed UFLS and distributed UVLS (see Table 3)		
Protection System Station DCdc supply used only for non-BES interrupting devices for RAS, non-distributed UFLS systems, or non-distributed UVLS systems is excluded (see Table 1-4(e)).		
Component Attributes	Maximum Maintenance Interval	Maintenance Activities
Protection System Station DCdc supply with Valve Regulated Lead-Acid (VRLA) batteries not having monitoring attributes of Table 1-4(f).	4 Calendar Months	Verify: <ul style="list-style-type: none"> • Station DCdc supply voltage Inspect: <ul style="list-style-type: none"> • For unintentional grounds
	6 Calendar Months	Inspect: <ul style="list-style-type: none"> • Condition of all individual units by measuring battery cell/unit internal ohmic values.
	18 Calendar Months	Verify: <ul style="list-style-type: none"> • Float voltage of battery charger • Battery continuity • Battery terminal connection resistance • Battery intercell or unit-to-unit connection resistance Inspect: <ul style="list-style-type: none"> • Physical condition of battery rack

Table 1-4(b) Component Type – Protection System Station DCdc Supply Using Valve-Regulated Lead-Acid (VRLA) Batteries Excluding distributed UFLS and distributed UVLS (see Table 3)		
Protection System Station DCdc supply used only for non-BES interrupting devices for RAS, non-distributed UFLS systems, or non-distributed UVLS systems is excluded (see Table 1-4(e)).		
Component Attributes	Maximum Maintenance Interval	Maintenance Activities
	6 Calendar Months -or- 3 Calendar Years	Verify that the station battery can perform as manufactured by evaluating cell/unit measurements indicative of battery performance (e.g. internal ohmic values or float current) against the station battery baseline. -or- Verify that the station battery can perform as manufactured by conducting a performance or modified performance capacity test of the entire battery bank.

Table 1-4(c) Component Type – Protection System Station DCdc Supply Using Nickel-Cadmium (NiCad) Batteries Excluding distributed UFLS and distributed UVLS (see Table 3)		
Protection System Station DCdc supply used only for non-BES interrupting devices for RAS, non-distributed UFLS system, or non-distributed UVLS systems is excluded (see Table 1-4(e)).		
Component Attributes	Maximum Maintenance Interval	Maintenance Activities
Protection System Station DCdc supply Nickel-Cadmium (NiCad) batteries not having monitoring attributes of Table 1-4(f).	4 Calendar Months	Verify: <ul style="list-style-type: none"> • Station DCdc supply voltage Inspect: <ul style="list-style-type: none"> • Electrolyte level • For unintentional grounds
	18 Calendar Months	Verify: <ul style="list-style-type: none"> • Float voltage of battery charger • Battery continuity • Battery terminal connection resistance • Battery intercell or unit-to-unit connection resistance Inspect: <ul style="list-style-type: none"> • Cell condition of all individual battery cells. • Physical condition of battery rack

Table 1-4(c)

Component Type – Protection System Station ~~DC~~ Supply Using Nickel-Cadmium (NiCad) Batteries
 Excluding distributed UFLS and distributed UVLS (see Table 3)

Protection System Station ~~DC~~ supply used only for non-BES interrupting devices for RAS, non-distributed UFLS system, or non-distributed UVLS systems is excluded (see Table 1-4(e)).

Component Attributes	Maximum Maintenance Interval	Maintenance Activities
	6 Calendar Years	Verify that the station battery can perform as manufactured by conducting a performance or modified performance capacity test of the entire battery bank.

Table 1-4(d) Component Type – Protection System Station <u>DCdc</u> Supply Using Non Battery Based Energy Storage Excluding distributed UFLS and distributed UVLS (see Table 3)		
Protection System Station <u>DCdc</u> supply used only for non-BES interrupting devices for RAS, non-distributed UFLS system, or non-distributed UVLS systems is excluded (see Table 1-4(e)).		
Component Attributes	Maximum Maintenance Interval	Maintenance Activities
Any Protection System station <u>DCdc</u> supply not using a battery and not having monitoring attributes of Table 1-4(f).	4 Calendar Months	Verify: <ul style="list-style-type: none"> • Station <u>DCdc</u> supply voltage Inspect: <ul style="list-style-type: none"> • For unintentional grounds
	18 Calendar Months	Inspect: Condition of non-battery based <u>DCdc</u> supply
	6 Calendar Years	Verify that the <u>DCdc</u> supply can perform as manufactured when <u>ACac</u> power is not present.

Table 1-4(e) Component Type – Protection System Station DCdc Supply for non-BES Interrupting Devices for RAS, non-distributed UFLS, and non-distributed UVLS systems		
Component Attributes	Maximum Maintenance Interval	Maintenance Activities
Any Protection System DCdc supply used for tripping only non-BES interrupting devices as part of a RAS, non-distributed UFLS, or non-distributed UVLS system and not having monitoring attributes of Table 1-4(f).	When control circuits are verified (See Table 1-5)	Verify Station DCdc supply voltage.

Table 1-4(f) Exclusions for Protection System Station DCdc Supply Monitoring Devices and Systems		
Component Attributes	Maximum Maintenance Interval	Maintenance Activities
Any station DCdc supply with high and low voltage monitoring and alarming of the battery charger voltage to detect charger overvoltage and charger failure (See Table 2).	No periodic maintenance specified	No periodic verification of station DCdc supply voltage is required.
Any battery based station DCdc supply with electrolyte level monitoring and alarming in every cell (See Table 2).		No periodic inspection of the electrolyte level for each cell is required.
Any station DCdc supply with unintentional DCdc ground monitoring and alarming (See Table 2).		No periodic inspection of unintentional DCdc grounds is required.
Any station DCdc supply with charger float voltage monitoring and alarming to ensure correct float voltage is being applied on the station DCdc supply (See Table 2).		No periodic verification of float voltage of battery charger is required.
Any battery based station DCdc supply with monitoring and alarming of battery string continuity (See Table 2).		No periodic verification of the battery continuity is required.
Any battery based station DCdc supply with monitoring and alarming of the intercell and/or terminal connection detail resistance of the entire battery (See Table 2).		No periodic verification of the intercell and terminal connection resistance is required.
Any Valve Regulated Lead-Acid (VRLA) or Vented Lead-Acid (VLA) station battery with internal ohmic value or float current monitoring and alarming, and evaluating present values relative to baseline internal ohmic values for every cell/unit (See Table 2).		No periodic evaluation relative to baseline of battery cell/unit measurements indicative of battery performance is required to verify the station battery can perform as manufactured.
Any Valve Regulated Lead-Acid (VRLA) or Vented Lead-Acid (VLA) station battery with monitoring and alarming of each cell/unit internal ohmic value (See Table 2).		No periodic inspection of the condition of all individual units by measuring battery cell/unit internal ohmic values of a station VRLA or Vented Lead-Acid (VLA) battery is required.

Table 1-5 Component Type - Control Circuitry Associated With Protective Functions Excluding distributed UFLS and distributed UVLS (see Table 3), Automatic Reclosing (see Table 4), and Sudden Pressure Relaying (see Table 5) Note: Table requirements apply to all Control Circuitry Components of Protection Systems, and RAS except as noted.		
Component Attributes	Maximum Maintenance Interval	Maintenance Activities
Trip coils or actuators of circuit breakers, interrupting devices, or mitigating devices (regardless of any monitoring of the control circuitry).	6 Calendar Years	Verify that each trip coil is able to operate the circuit breaker, interrupting device, or mitigating device.
Electromechanical lockout devices which are directly in a trip path from the protective relay to the interrupting device trip coil (regardless of any monitoring of the control circuitry).	6 Calendar Years	Verify electrical operation of electromechanical lockout devices.
Unmonitored control circuitry associated with RAS. (See Table 4-2(b) for RAS which include Automatic Reclosing.)	12 Calendar Years	Verify all paths of the control circuits essential for proper operation of the RAS.
Unmonitored control circuitry associated with protective functions inclusive of all auxiliary relays.	12 Calendar Years	Verify all paths of the trip circuits inclusive of all auxiliary relays through the trip coil(s) of the circuit breakers or other interrupting devices.
Control circuitry associated with protective functions and/or RAS whose integrity is monitored and alarmed (See Table 2).	No periodic maintenance specified	None.

Table 2 – Alarming Paths and Monitoring In Tables 1-1 through 1-5, Table 3, Tables 4-1 through 4-3, and Table 5 alarm attributes used to justify extended maximum maintenance intervals and/or reduced maintenance activities are subject to the following maintenance requirements		
Component Attributes	Maximum Maintenance Interval	Maintenance Activities
Any alarm path through which alarms in Tables 1-1 through 1-5, Table 3, Tables 4-1 through 4-3, and Table 5 are conveyed from the alarm origin to the location where corrective action can be initiated, and not having all the attributes of the “Alarm Path with monitoring” category below. Alarms are reported within 24 hours of detection to a location where corrective action can be initiated.	12 Calendar Years	Verify that the alarm path conveys alarm signals to a location where corrective action can be initiated.
Alarm Path with monitoring: The location where corrective action is taken receives an alarm within 24 hours for failure of any portion of the alarming path from the alarm origin to the location where corrective action can be initiated.	No periodic maintenance specified	None.

Table 3 Maintenance Activities and Intervals for distributed UFLS and distributed UVLS Systems		
Component Attributes	Maximum Maintenance Interval	Maintenance Activities
Any unmonitored protective relay not having all the monitoring attributes of a category below.	6 Calendar Years	<p>Verify that settings are as specified.</p> <p>For non-microprocessor relays:</p> <ul style="list-style-type: none"> • Test and, if necessary calibrate. <p>For microprocessor relays:</p> <ul style="list-style-type: none"> • Verify operation of the relay inputs and outputs that are essential to proper functioning of the Protection System. • Verify acceptable measurement of power system input values.
<p>Monitored microprocessor protective relay with the following:</p> <ul style="list-style-type: none"> • Internal self-diagnosis and alarming (See Table 2). • Voltage and/or current waveform sampling three or more times per power cycle, and conversion of samples to numeric values for measurement calculations by microprocessor electronics. <p>Alarming for power supply failure (See Table 2).</p>	12 Calendar Years	<p>Verify:</p> <ul style="list-style-type: none"> • Settings are as specified. • Operation of the relay inputs and outputs that are essential to proper functioning of the Protection System. • Acceptable measurement of power system input values.
<p>Monitored microprocessor protective relay with preceding row attributes and the following:</p> <ul style="list-style-type: none"> • A_{Ce} measurements are continuously verified by comparison to an independent A_{Cac} measurement source, with alarming for excessive error (See Table 2). 	12 Calendar Years	<p>Verify only the unmonitored relay inputs and outputs that are essential to proper functioning of the Protection System.</p>

Table 3 Maintenance Activities and Intervals for distributed UFLS and distributed UVLS Systems		
Component Attributes	Maximum Maintenance Interval	Maintenance Activities
<ul style="list-style-type: none"> Some or all binary or status inputs and control outputs are monitored by a process that continuously demonstrates ability to perform as designed, with alarming for failure (See Table 2). Alarming for change of settings (See Table 2).		
Voltage and/or current sensing devices associated with UFLS or UVLS systems.	12 Calendar Years	Verify that current and/or voltage signal values are provided to the protective relays.
Protection System DCdc supply for tripping non-BES interrupting devices used only for a UFLS or UVLS system.	12 Calendar Years	Verify Protection System DCdc supply voltage.
Control circuitry between the UFLS or UVLS relays and electromechanical lockout and/or tripping auxiliary devices (excludes non-BES interrupting device trip coils).	12 Calendar Years	Verify the path from the relay to the lockout and/or tripping auxiliary relay (including essential supervisory logic).
Electromechanical lockout and/or tripping auxiliary devices associated only with UFLS or UVLS systems (excludes non-BES interrupting device trip coils).	12 Calendar Years	Verify electrical operation of electromechanical lockout and/or tripping auxiliary devices.
Control circuitry between the electromechanical lockout and/or tripping auxiliary devices and the non-BES interrupting devices in UFLS or UVLS systems, or between UFLS or UVLS relays (with no interposing electromechanical lockout or auxiliary device) and the non-BES interrupting devices (excludes non-BES interrupting device trip coils).	No periodic maintenance specified	None.
Trip coils of non-BES interrupting devices in UFLS or UVLS systems.	No periodic maintenance specified	None.

Table 4-1 Maintenance Activities and Intervals for Automatic Reclosing Components Component Type – Reclosing and Supervisory Relay		
Note: In cases where Components of Automatic Reclosing are common to Components listed in Table 1-1 through 1-5, the Components only need to be tested once during a distinct maintenance interval.		
Component Attributes	Maximum Maintenance Interval	Maintenance Activities
Any unmonitored reclosing relay or supervisory relay not having all the monitoring attributes of a category below.	6 Calendar Years	Verify that settings are as specified. For non-microprocessor <u>reclosing or supervisory</u> relays: <ul style="list-style-type: none"> • Test and, if necessary calibrate For microprocessor <u>reclosing or supervisory</u> relays: <ul style="list-style-type: none"> • Verify operation of the relay inputs and outputs that are essential to proper functioning of the Automatic Reclosing. For microprocessor supervisory relays: <ul style="list-style-type: none"> • Verify acceptable measurement of power system input values.
<ul style="list-style-type: none"> • Monitored microprocessor reclosing relay or supervisory relay with the following: Internal self-diagnosis and alarming (See Table 2). • Alarming for power supply failure (See Table 2). For supervisory relay: <ul style="list-style-type: none"> • Voltage waveform sampling three or more times per power cycle, and conversion of samples to numeric values for measurement calculations by microprocessor electronics. 	12 Calendar Years	Verify: <ul style="list-style-type: none"> • Settings are as specified. • Operation of the relay inputs and outputs that are essential to proper functioning of the Automatic Reclosing. For supervisory relays: <ul style="list-style-type: none"> • Verify acceptable measurement of power system input values.

Table 4-1 Maintenance Activities and Intervals for Automatic Reclosing Components Component Type – Reclosing and Supervisory Relay		
Note: In cases where Components of Automatic Reclosing are common to Components listed in Table 1-1 through 1-5, the Components only need to be tested once during a distinct maintenance interval.		
Component Attributes	Maximum Maintenance Interval	Maintenance Activities
Monitored microprocessor reclosing relay or supervisory relay with preceding row attributes and the following: <ul style="list-style-type: none"> Some or all binary or status inputs and control outputs are monitored by a process that continuously demonstrates ability to perform as designed, with alarming for failure (See Table 2). Alarming for change of settings (See Table 2). For supervisory relay: <ul style="list-style-type: none"> A_{cE} measurements are continuously verified by comparison to an independent A_{cAc} measurement source, with alarming for excessive error (See Table 2). 	12 Calendar Years	Verify only the unmonitored relay inputs and outputs that are essential to proper functioning of the Automatic Reclosing.

Table 4-2(a)

Maintenance Activities and Intervals for Automatic Reclosing Components

Component Type – Control Circuitry Associated with Reclosing and Supervisory Relays that are NOT an Integral Part of an RAS

Note: In cases where Components of ~~Automatic Reclosing Sudden Pressure Relaying~~ are common to Components listed in Table 1-5, the Components only need to be tested once during a distinct maintenance interval.

Component Attributes	Maximum Maintenance Interval	Maintenance Activities
Unmonitored Control circuitry associated with Automatic Reclosing that is not an integral part of an RAS.	12 Calendar Years	Verify that Automatic Reclosing, upon initiation, does not issue a premature closing command to the close circuitry.
Control circuitry associated with Automatic Reclosing that is not part of an RAS and is monitored and alarmed for conditions that would result in a premature closing command. (See Table 2)	No periodic maintenance specified	None.

Table 4-2(b)

Maintenance Activities and Intervals for Automatic Reclosing Components

Component Type – Control Circuitry Associated with Reclosing and Supervisory Relays that ARE an Integral Part of an RAS

Note: In cases where Components of Automatic Reclosing Sudden Pressure Relaying are common to Components listed in Table 1-5, the Components only need to be tested once during a distinct maintenance interval.

Component Attributes	Maximum Maintenance Interval	Maintenance Activities
Close coils or actuators of circuit breakers or similar devices that are used in conjunction with Automatic Reclosing as part of an RAS (regardless of any monitoring of the control circuitry).	6 Calendar Years	Verify that each close coil or actuator is able to operate the circuit breaker or mitigating device.
Unmonitored close control circuitry associated with Automatic Reclosing used as an integral part of an RAS.	12 Calendar Years	Verify all paths of the control circuits associated with Automatic Reclosing that are essential for proper operation of the RAS.
Control circuitry associated with Automatic Reclosing that is an integral part of an RAS whose integrity is monitored and alarmed. (See Table 2)	No periodic maintenance specified	None.

Table 4-3 Maintenance Activities and Intervals for Automatic Reclosing Components Component Type – Voltage Sensing Devices Associated with Supervisory Relays Note: In cases where Components of Automatic Reclosing Sudden Pressure Relaying are common to Components listed in Table 1- 25 , the Components only need to be tested once during a distinct maintenance interval.		
Component Attributes	Maximum Maintenance Interval	Maintenance Activities
Any voltage sensing devices not having monitoring attributes of the category below.	12 Calendar Years	Verify that voltage signal values are provided to the supervisory relays.
Voltage sensing devices that are connected to microprocessor supervisory relays with ACac measurements that are continuously verified by comparison of sensing input value, as measured by the microprocessor relay, to an independent ACac measurement source, with alarming for unacceptable error or failure. (See Table 2)	No periodic maintenance specified	None.

Table 5 Maintenance Activities and Intervals for Sudden Pressure Relaying		
Note: In cases where Components of Sudden Pressure Relaying are common to Components listed in Table 1-5, the Components only need to be tested once during a distinct maintenance interval.		
Component Attributes	Maximum Maintenance Interval	Maintenance Activities
Any fault pressure relay.	6 Calendar Years	Verify the pressure or flow sensing mechanism is operable.
Electromechanical lockout devices which are directly in a trip path from the fault pressure relay to the interrupting device trip coil (regardless of any monitoring of the control circuitry).	6 Calendar Years	Verify electrical operation of electromechanical lockout devices.
Unmonitored control circuitry associated with Sudden Pressure Relaying.	12 Calendar Years	Verify all paths of the trip circuits inclusive of all auxiliary relays through the trip coil(s) of the circuit breakers or other interrupting devices.
Control circuitry associated with Sudden Pressure Relaying whose integrity is monitored and alarmed (See Table 2).	No periodic maintenance specified	None.

PRC-005 — Attachment A

Criteria for a Performance-Based Protection System Maintenance Program

Purpose: To establish a technical basis for initial and continued use of a performance-based Protection System Maintenance Program (PSMP).

To establish the technical justification for the initial use of a performance-based PSMP:

1. Develop a list with a description of Components included in each designated Segment, with a minimum Segment population of 60 Components.
2. Maintain the Components in each Segment according to the time-based maximum allowable intervals established in Tables 1-1 through 1-5, Table 3, Tables 4-1 through 4-3, and Table 5 until results of maintenance activities for the Segment are available for a minimum of 30 individual Components of the Segment.
3. Document the maintenance program activities and results for each Segment, including maintenance dates and Countable Events for each included Component.
4. Analyze the maintenance program activities and results for each Segment to determine the overall performance of the Segment and develop maintenance intervals.
5. Determine the maximum allowable maintenance interval for each Segment such that the Segment experiences Countable Events on no more than 4% of the Components within the Segment, for the greater of either the last 30 Components maintained or all Components maintained in the previous year.

To maintain the technical justification for the ongoing use of a performance-based PSMP:

1. At least annually, update the list of Components and Segments and/or description if any changes occur within the Segment.
2. Perform maintenance on the greater of 5% of the Components (addressed in the performance based PSMP) in each Segment or 3 individual Components within the Segment in each year.
3. For the prior year, analyze the maintenance program activities and results for each Segment to determine the overall performance of the Segment.
4. Using the prior year's data, determine the maximum allowable maintenance interval for each Segment such that the Segment experiences Countable Events on no more than 4% of the Components within the Segment, for the greater of either the last 30 Components maintained or all Components maintained in the previous year.

If the Components in a Segment maintained through a performance-based PSMP experience 4% or more Countable Events, develop, document, and implement an action plan to reduce the Countable Events to less than 4% of the Segment population within 3 years.

Rationale:

During development of this standard, text boxes were embedded within the standard to explain the rationale for various parts of the standard. Upon BOT approval, the text from the rationale text boxes was moved to this section.

Standard Development Timeline

This section is maintained by the drafting team during the development of the standard and will be removed when the standard becomes effective.

Development Steps Completed

1. SAR posted for comment March 12 – April 10, 2015.
2. Revised SAR reposted with revisions for comment June 11 – July 10, 2015

Description of Current Draft

This version of PRC-005 was posted for a 45-day concurrent comment and ballot period to address directives from [FERC Order No. 803](#), addressing Automatic Reclosing. Specifically, supervisory relays, associated voltage sensing devices, and associated control circuitry were added.

Anticipated Actions	Anticipated Dates
45-day Formal Comment Period with Concurrent Ballot	July 2015 – September 2015
Final ballot	October 2015
BOT adoption	November 2015

Definitions of Terms Used in Standard

This section includes all newly defined or revised terms used in the proposed standard. Terms already defined in the Reliability Standards Glossary of Terms (Glossary) are not repeated here. New or revised definitions listed below become approved when the proposed standard is approved. When the standard becomes effective, this defined term will be removed from the individual standard and added to the Glossary.

See Section 6 of the Standard

A. Introduction

1. **Title:** Protection System, Automatic Reclosing, and Sudden Pressure Relaying Maintenance
2. **Number:** PRC-005-~~65~~
3. **Purpose:** To document and implement programs for the maintenance of all Protection Systems, Automatic Reclosing, and Sudden Pressure Relaying affecting the reliability of the Bulk Electric System (BES) so that they are kept in working order.
4. **Applicability:**
 - 4.1. **Functional Entities:**
 - 4.1.1 Transmission Owner
 - 4.1.2 Generator Owner
 - 4.1.3 Distribution Provider
 - 4.2. **Facilities:**
 - 4.2.1 Protection Systems and Sudden Pressure Relaying that are installed for the purpose of detecting Faults on BES Elements (lines, buses, transformers, etc.)
 - 4.2.2 Protection Systems used for underfrequency load-shedding systems installed per ERO underfrequency load-shedding requirements.
 - 4.2.3 Protection Systems used for undervoltage load-shedding systems installed to prevent system voltage collapse or voltage instability for BES reliability.
 - 4.2.4 Protection Systems installed as a Remedial Action Scheme (RAS) for BES reliability.
 - 4.2.5 Protection Systems and Sudden Pressure Relaying for generator Facilities that are part of the BES, except for generators identified through Inclusion I4 of the BES definition, including:
 - 4.2.5.1 Protection Systems that act to trip the generator either directly or via lockout or auxiliary tripping relays.
 - 4.2.5.2 Protection Systems and Sudden Pressure Relaying for generator step-up transformers for generators that are part of the BES.
 - 4.2.5.3 Protection Systems and Sudden Pressure Relaying for station service or excitation transformers connected to the generator bus of generators which are part of the BES, that act to trip the generator either directly or via lockout or tripping auxiliary relays.

4.2.6 Protection Systems and Sudden Pressure Relaying for the following BES generator Facilities for dispersed power producing resources identified through Inclusion I4 of the BES definition:

4.2.6.1 Protection Systems and Sudden Pressure Relaying for Facilities used in aggregating dispersed BES generation from the point where those resources aggregate to greater than 75 MVA to a common point of connection at 100kV or above.

4.2.7 Automatic Reclosing¹, including:

4.2.7.1 Automatic Reclosing applied on the terminals of Elements connected to the BES bus located at generating plant substations where the total installed gross generating plant capacity is greater than the gross capacity of the largest BES generating unit within the Balancing Authority Area or, if a member of a Reserve Sharing Group, the largest generating unit within the Reserve Sharing Group.²

4.2.7.2 Automatic Reclosing applied on the terminals of all BES Elements at substations one bus away from generating plants specified in Section 4.2.7.1 when the substation is less than 10 circuit-miles from the generating plant substation.

4.2.7.3 Automatic Reclosing applied as an integral part of an RAS specified in Section 4.2.4.

5. Effective Date: See the Implementation Plan for this standard.

6. Definitions Used in this Standard:

¹ Automatic Reclosing addressed in Section 4.2.7.1 and 4.2.7.2 may be excluded if the equipment owner can demonstrate that a close-in three-phase fault present for twice the normal clearing time (capturing a minimum trip-close-trip time delay) does not result in a total loss of gross generation in the Interconnection exceeding the gross capacity of the largest relevant BES generating unit where the Automatic Reclosing is applied.

² The largest BES generating unit within the Balancing Authority Area or the largest generating unit within the Reserve Sharing Group, as applicable, is subject to change. As a result of such a change, the Automatic Reclosing Components subject to the standard could change effective on the date of such change.

Automatic Reclosing – Includes the following Components:

- Reclosing relay
- Supervisory relay(s) or function(s) – relay(s) or function(s) that perform voltage and/or sync check functions that enable or disable operation of the reclosing relay
- Voltage sensing devices associated with the supervisory relay(s) or function(s)
- Control circuitry associated with the reclosing relay or supervisory relay(s) or function(s)

Rationale for revisions to Automatic Reclosing: To address directives from FERC Order No. 803 addressing Automatic Reclosing, the definition for Automatic Reclosing was revised to add supervisory relays, the associated voltage sensing devices, and the associated control circuitry.

Sudden Pressure Relaying – A system that trips an interrupting device(s) to isolate the equipment it is monitoring and includes the following Components:

- Fault pressure relay – a mechanical relay or device that detects rapid changes in gas pressure, oil pressure, or oil flow that are indicative of Faults within liquid-filled, wire-wound equipment
- Control circuitry associated with a fault pressure relay

Unresolved Maintenance Issue – A deficiency identified during a maintenance activity that causes the Component to not meet the intended performance, cannot be corrected during the maintenance interval, and requires follow-up corrective action.

Segment – Components of a consistent design standard, or a particular model or type from a single manufacturer that typically share other common elements. Consistent performance is expected across the entire population of a Segment. A Segment must contain at least sixty (60) individual Components.

Component Type –

- Any one of the five specific elements of a Protection System.
- Any one of the ~~two~~ four specific elements of Automatic Reclosing.
- Any one of the two specific elements of Sudden Pressure Relaying.

Rationale for revisions to Component Type: With the revision of the definition of Automatic Reclosing, there are four specific elements of this definition, rather than two as stated in the prior version.

Component – Any individual discrete piece of equipment included in a Protection System, Automatic Reclosing, or Sudden Pressure Relaying.

Countable Event – A failure of a Component requiring repair or replacement, any condition discovered during the maintenance activities in Tables 1-1 through 1-5, Table 3, Tables 4-1 through 4-~~32~~, and Table 5, which requires corrective action or a Protection System Misoperation attributed to hardware failure or calibration failure. Misoperations due to product design errors, software errors, relay settings different from specified settings, Protection System Component, Automatic Reclosing, or Sudden Pressure Relaying configuration or application errors are not included in Countable Events.

B. Requirements and Measures

- R1.** Each Transmission Owner, Generator Owner, and Distribution Provider shall establish a Protection System Maintenance Program (PSMP) for its Protection Systems, Automatic Reclosing, and Sudden Pressure Relaying identified in Section 4.2, Facilities. *[Violation Risk Factor: Medium] [Time Horizon: Operations Planning]*

The PSMP shall:

- 1.1.** Identify which maintenance method (time-based, performance-based per PRC-005 Attachment A, or a combination) is used to address each Protection System, Automatic Reclosing, and Sudden Pressure Relaying Component Type. All batteries associated with the station dc supply Component Type of a Protection System shall be included in a time-based program as described in Table 1-4 and Table 3.
 - 1.2.** Include the applicable monitored Component attributes applied to each Protection System, Automatic Reclosing, and Sudden Pressure Relaying Component Type consistent with the maintenance intervals specified in Tables 1-1 through 1-5, Table 2, Table 3, Table 4-1 through 4-~~332~~, and Table 5 where monitoring is used to extend the maintenance intervals beyond those specified for unmonitored Protection System, Automatic Reclosing, and Sudden Pressure Relaying Components.
- M1.** Each Transmission Owner, Generator Owner and Distribution Provider shall have a documented ~~PSM~~[Protection System Maintenance Program](#) in accordance with Requirement R1.

For each Protection System, Automatic Reclosing, and Sudden Pressure Relaying Component Type, the documentation shall include the type of maintenance method applied (time-based, performance-based, or a combination of these maintenance methods), and shall include all batteries associated with the station dc supply Component Types in a time-based program as described in Table 1-4 and Table 3. (Part 1.1)

For Component Types that use monitoring to extend the maintenance intervals, the responsible entity(s) shall have evidence for each Protection System, Automatic Reclosing, and Sudden Pressure Relaying Component Type (such as manufacturer's specifications or engineering drawings) of the appropriate monitored Component

attributes as specified in Tables 1-1 through 1-5, Table 2, Table 3, Table 4-1 through 4-32, and Table 5. (Part 1.2)

- R2.** Each Transmission Owner, Generator Owner, and Distribution Provider that uses performance-based maintenance intervals in its PSMP shall follow the procedure established in PRC-005 Attachment A to establish and maintain its performance-based intervals. *[Violation Risk Factor: Medium] [Time Horizon: Operations Planning]*
- M2.** Each Transmission Owner, Generator Owner, and Distribution Provider that uses performance-based maintenance intervals shall have evidence that its current performance-based maintenance program(s) is in accordance with Requirement R2, which may include, but is not limited to, Component lists, dated maintenance records, and dated analysis records and results.
- R3.** Each Transmission Owner, Generator Owner, and Distribution Provider that utilizes time-based maintenance program(s) shall maintain its Protection System, Automatic Reclosing, and Sudden Pressure Relaying Components that are included within the time-based maintenance program in accordance with the minimum maintenance activities and maximum maintenance intervals prescribed within Tables 1-1 through 1-5, Table 2, Table 3, Table 4-1 through 4-32, and Table 5. *[Violation Risk Factor: High] [Time Horizon: Operations Planning]*
- M3.** Each Transmission Owner, Generator Owner, and Distribution Provider that utilizes time-based maintenance program(s) shall have evidence that it has maintained its Protection System, Automatic Reclosing, and Sudden Pressure Relaying Components included within its time-based program in accordance with Requirement R3. The evidence may include, but is not limited to, dated maintenance records, dated maintenance summaries, dated check-off lists, dated inspection records, or dated work orders.
- R4.** Each Transmission Owner, Generator Owner, and Distribution Provider that utilizes performance-based maintenance program(s) in accordance with Requirement R2 shall implement and follow its PSMP for its Protection System, Automatic Reclosing, and Sudden Pressure Relaying Components that are included within the performance-based program(s). *[Violation Risk Factor: High] [Time Horizon: Operations Planning]*
- M4.** Each Transmission Owner, Generator Owner, and Distribution Provider that utilizes performance-based maintenance intervals in accordance with Requirement R2 shall have evidence that it has implemented the [PSMP Protection System Maintenance Program](#) for the Protection System, Automatic Reclosing, and Sudden Pressure Relaying Components included in its performance-based program in accordance with Requirement R4. The evidence may include, but is not limited to, dated maintenance records, dated maintenance summaries, dated check-off lists, dated inspection records, or dated work orders.
- R5.** Each Transmission Owner, Generator Owner, and Distribution Provider shall demonstrate efforts to correct identified Unresolved Maintenance Issues. *[Violation Risk Factor: Medium] [Time Horizon: Operations Planning]*

- M5.** Each Transmission Owner, Generator Owner, and Distribution Provider shall have evidence that it has undertaken efforts to correct identified Unresolved Maintenance Issues in accordance with Requirement R5. The evidence may include, but is not limited to, work orders, replacement Component orders, invoices, project schedules with completed milestones, return material authorizations (RMAs) or purchase orders.

C. Compliance

1. Compliance Monitoring Process

1.1. Compliance Enforcement Authority

As defined in the NERC Rules of Procedure, “Compliance Enforcement Authority” means NERC or the Regional Entity in their respective roles of monitoring and enforcing compliance with the NERC Reliability Standards.

1.2. Evidence Retention

The following evidence retention periods identify the period of time an entity is required to retain specific evidence to demonstrate compliance. For instances where the evidence retention period specified below is shorter than the time since the last audit, the Compliance Enforcement Authority may ask an entity to provide other evidence to show that it was compliant for the full time period since the last audit.

The Transmission Owner, Generator Owner, and Distribution Provider shall each keep data or evidence to show compliance as identified below unless directed by its Compliance Enforcement Authority to retain specific evidence for a longer period of time as part of an investigation.

For Requirement R1, the Transmission Owner, Generator Owner, and Distribution Provider shall each keep its current dated [PSMProtection System Maintenance Program](#), as well as any superseded versions since the preceding compliance audit, including the documentation that specifies the type of maintenance program applied for each Protection System, Automatic Reclosing, or Sudden Pressure Relaying Component Type.

For Requirement R2, Requirement R3, and Requirement R4, in cases where the interval of the maintenance activity is longer than the audit cycle, the Transmission Owner, Generator Owner, and Distribution Provider shall each keep documentation of the most recent performance of that maintenance activity for the Protection System, Automatic Reclosing, or Sudden Pressure Relaying Component. In cases where the interval of the maintenance activity is shorter than the audit cycle, documentation of all performances (in accordance with the tables) of that maintenance activity for the Protection System,

Automatic Reclosing, or Sudden Pressure Relaying Component since the previous scheduled audit date shall be retained.

For Requirement R5 the Transmission Owner, Generator Owner, and Distribution Provider shall each keep documentation of Unresolved Maintenance Issues identified by the entity since the last audit, including all that were resolved since the last audit.

~~The Compliance Enforcement Authority shall keep the last audit records and all requested and submitted subsequent audit records.~~

1.3. Compliance Monitoring and Assessment Processes:

Compliance Audits

Self-Certifications

Spot Checking

Compliance ~~Violation~~ Investigations

Self-Reporting

Complaints

1.4. Additional Compliance Information

None

Table of Compliance Elements

Requirement Number	Lower VSL	Moderate VSL	High VSL	Severe VSL
R1	The entity's PSMP failed to specify whether one Component Type is being addressed by time-based or performance-based maintenance, or a combination of both (Part 1.1).	The entity's PSMP failed to specify whether two Component Types are being addressed by time-based or performance-based maintenance, or a combination of both (Part 1.1).	The entity's PSMP failed to specify whether three Component Types are being addressed by time-based or performance-based maintenance, or a combination of both. (Part 1.1). OR The entity's PSMP failed to include the applicable monitoring attributes applied to each Component Type consistent with the maintenance intervals specified in Tables 1-1 through 1-5, Table 2, Table 3, Tables 4-1 through 4-32, and Table 5 where monitoring is used to extend the maintenance intervals beyond those specified for unmonitored Components (Part 1.2).	The entity failed to establish a PSMP. OR The entity's PSMP failed to specify whether four or more Component Types are being addressed by time-based or performance-based maintenance, or a combination of both (Part 1.1). OR The entity's PSMP failed to include applicable station batteries in a time-based program (Part 1.1).
R2	The entity uses performance-based maintenance intervals in its PSMP but failed to reduce Countable Events to no more than 4% within three years.	NA	The entity uses performance-based maintenance intervals in its PSMP but failed to reduce Countable Events to no more than 4% within four years.	The entity uses performance-based maintenance intervals in its PSMP but: 1) Failed to establish the technical justification described within Requirement R2 for the initial use of the performance-based PSMP OR 2) Failed to reduce Countable Events to no more than 4% within five years OR

Requirement Number	Lower VSL	Moderate VSL	High VSL	Severe VSL
				3) Maintained a Segment with less than 60 Components OR 4) Failed to: <ul style="list-style-type: none"> • Annually update the list of Components, OR • Annually perform maintenance on the greater of 5% of the Segment population or 3 Components, OR • Annually analyze the program activities and results for each Segment.
R3	For Components included within a time-based maintenance program, the entity failed to maintain 5% or less of the total Components included within a specific Component Type in accordance with the minimum maintenance activities and maximum maintenance intervals prescribed within Tables 1-1 through 1-5, Table 2, Table 3, Tables 4-1 through 4-23, and Table 5.	For Components included within a time-based maintenance program, the entity failed to maintain more than 5% but 10% or less of the total Components included within a specific Component Type in accordance with the minimum maintenance activities and maximum maintenance intervals prescribed within Tables 1-1 through 1-5, Table 2, Table 3, Tables 4-1 through 4-23, and Table 5.	For Components included within a time-based maintenance program, the entity failed to maintain more than 10% but 15% or less of the total Components included within a specific Component Type in accordance with the minimum maintenance activities and maximum maintenance intervals prescribed within Tables 1-1 through 1-5, Table 2, Table 3, Tables 4-1 through 4-23, and Table 5.	For Components included within a time-based maintenance program, the entity failed to maintain more than 15% of the total Components included within a specific Component Type in accordance with the minimum maintenance activities and maximum maintenance intervals prescribed within Tables 1-1 through 1-5, Table 2, Table 3, Tables 4-1 through 4-23, and Table 5.

Requirement Number	Lower VSL	Moderate VSL	High VSL	Severe VSL
R4	For Components included within a performance-based maintenance program, the entity failed to maintain 5% or less of the annual scheduled maintenance for a specific Component Type in accordance with their performance-based PSMP.	For Components included within a performance-based maintenance program, the entity failed to maintain more than 5% but 10% or less of the annual scheduled maintenance for a specific Component Type in accordance with their performance-based PSMP.	For Components included within a performance-based maintenance program, the entity failed to maintain more than 10% but 15% or less of the annual scheduled maintenance for a specific Component Type in accordance with their performance-based PSMP.	For Components included within a performance-based maintenance program, the entity failed to maintain more than 15% of the annual scheduled maintenance for a specific Component Type in accordance with their performance-based PSMP.
R5	The entity failed to undertake efforts to correct 5 or fewer identified Unresolved Maintenance Issues.	The entity failed to undertake efforts to correct greater than 5 but less than or equal to 10 identified Unresolved Maintenance Issues.	The entity failed to undertake efforts to correct greater than 10 but less than or equal to 15 identified Unresolved Maintenance Issues.	The entity failed to undertake efforts to correct greater than 15 identified Unresolved Maintenance Issues.

D. Regional Variances

None.

E. Interpretations

None.

Supplemental Reference Documents

The following documents present a detailed discussion about determination of maintenance intervals and other useful information regarding establishment of a maintenance program.

1. *Supplementary Reference and FAQ - PRC-005-64 Protection System Maintenance*, Protection System Maintenance and Testing Standard Drafting Team (April 2015)
2. *Considerations for Maintenance and Testing of Auto-reclosing Schemes*, NERC System Analysis and Modeling Subcommittee, and NERC System Protection and Control Subcommittee (November 2012)
3. *Sudden Pressure Relays and Other Devices that Respond to Non-Electrical Quantities – SPCS Input for Standard Development in Response to FERC Order No. 758*, NERC System Protection and Control Subcommittee (December 2013)
4. *Sudden Pressure Relays and Other Devices that Respond to Non-Electrical Quantities – Supplemental Information to Support Project 2007-17.3: Protection System Maintenance and Testing* (October 31, 2014)

Version History

Version	Date	Action	Change Tracking
0	February 8, 2005	Adopted by NERC Board of Trustees	New.
1	February 7, 2006	Adopted by NERC Board of Trustees	<ol style="list-style-type: none"> 1. Changed incorrect use of certain hyphens (-) to “en dash” (–) and “em dash (—).” 2. Added “periods” to items where appropriate. Changed “Timeframe” to “Time Frame” in item D, 1.2.
1a	February 17, 2011	Adopted by NERC Board of Trustees	Added Appendix 1 - Interpretation regarding applicability of standard to protection of radially connected transformers developed in Project 2009-17.

Version	Date	Action	Change Tracking
1b	November 5, 2009	Adopted by NERC Board of Trustees	Interpretation of R1, R1.1, and R1.2 developed by Project 2009-10.
1b	February 3, 2012	FERC Order approving revised definition of “Protection System”	Per footnote 8 of FERC’s order, the definition of “Protection System” supersedes interpretation “b” of PRC-005-1b upon the effective date of the modified definition (i.e., April 1, 2013). <i>See N. Amer. Elec. Reliability Corp., 138 FERC ¶ 61,095 (February 3, 2012).</i>
1.1b	May 9, 2012	Adopted by NERC Board of Trustees	Errata change developed by Project 2010-07, clarified inclusion of generator interconnection Facility in Generator Owner’s responsibility.
2	November 7, 2012	Adopted by NERC Board of Trustees	Project 2007-17 - Complete revision, absorbing maintenance requirements from PRC-005-1.1b, PRC-008-0, PRC-011-0, PRC-017-0.
2	October 17, 2013	Approved by NERC Standards Committee	Errata Change: The Standards Committee approved an errata change to the implementation plan for PRC-005-2 to add the phrase “or as otherwise made effective pursuant to the laws applicable to such ERO governmental authorities;” to the second sentence under the “Retirement of Existing Standards” section. (no change to standard version number)
2	March 7, 2014	Adopted by NERC Board of Trustees	Modified R1 VSL in response to FERC directive (no change to standard version number).
2(i)	November 13, 2014	Adopted by NERC Board of Trustees	Applicability section revised by Project 2014-01 to clarify application of Requirements to BES dispersed power producing resources.

Version	Date	Action	Change Tracking
2(ii)	November 13, 2014	Adopted by NERC Board of Trustees	Replaced references to Special Protection System and SPS with Remedial Action Scheme and RAS.
3	November 7, 2013	Adopted by the NERC Board of Trustees	Revised to address the FERC directive in Order No. 758 to include Automatic Reclosing in maintenance programs.
3	February 12, 2014	Approved by NERC Standards Committee	Errata Change: The Standards Committee approved errata changes to correct capitalization of certain defined terms within the definitions of “Unresolved Maintenance Issue” and “Protection System Maintenance Program”. The changes will be reflected in the definitions section of PRC-005-3 for “Unresolved Maintenance Issue” and in the NERC Glossary of Terms for “Protection System Maintenance Program”. (no change to standard version number)
3	March 7, 2014	Adopted by NERC Board of Trustees	Modified R1 VSL in response to FERC directive (no change to standard version number).
3(i)	November 13, 2014	Adopted by NERC Board of Trustees	Applicability section revised by Project 2014-01 to clarify application of Requirements to BES dispersed power producing resources.
3(ii)	November 13, 2014	Adopted by NERC Board of Trustees	Replaced references to Special Protection System and SPS with Remedial Action Scheme and RAS.
4	November 13, 2014	Adopted by NERC Board of Trustees	Added Sudden Pressure Relaying in response to FERC Order No. 758.

Version	Date	Action	Change Tracking
5	TBD		Applicability section revised by Project 2014-01 to clarify application of Requirements to BES dispersed power producing resources.
<u>6</u>	<u>TBD</u>		<u>Revised to add supervisory relays, the voltage sensing devices, and the associated control circuitry to Automatic Reclosing in accordance with the directives in FERC Order 803.</u>

Table 1-1 Component Type - Protective Relay Excluding distributed UFLS and distributed UVLS (see Table 3)		
Component Attributes	Maximum Maintenance Interval ³	Maintenance Activities
Any unmonitored protective relay not having all the monitoring attributes of a category below.	6 Calendar Years	For all unmonitored relays: <ul style="list-style-type: none"> • Verify that settings are as specified For non-microprocessor relays: <ul style="list-style-type: none"> • Test and, if necessary calibrate For microprocessor relays: <ul style="list-style-type: none"> • Verify operation of the relay inputs and outputs that are essential to proper functioning of the Protection System. • Verify acceptable measurement of power system input values.
Monitored microprocessor protective relay with the following: <ul style="list-style-type: none"> • Internal self-diagnosis and alarming (see Table 2). • Voltage and/or current waveform sampling three or more times per power cycle, and conversion of samples to numeric values for measurement calculations by microprocessor electronics. • Alarming for power supply failure (see Table 2). 	12 Calendar Years	Verify: <ul style="list-style-type: none"> • Settings are as specified. • Operation of the relay inputs and outputs that are essential to proper functioning of the Protection System. • Acceptable measurement of power system input values.

³ For the tables in this standard, a calendar year starts on the first day of a new year (January 1) after a maintenance activity has been completed. For the tables in this standard, a calendar month starts on the first day of the first month after a maintenance activity has been completed.

Table 1-1 Component Type - Protective Relay Excluding distributed UFLS and distributed UVLS (see Table 3)		
Component Attributes	Maximum Maintenance Interval ³	Maintenance Activities
Monitored microprocessor protective relay with preceding row attributes and the following: <ul style="list-style-type: none"> • ϵAc measurements are continuously verified by comparison to an independent ac measurement source, with alarming for excessive error (See Table 2). • Some or all binary or status inputs and control outputs are monitored by a process that continuously demonstrates ability to perform as designed, with alarming for failure (See Table 2). • Alarming for change of settings (See Table 2). 	12 Calendar Years	Verify only the unmonitored relay inputs and outputs that are essential to proper functioning of the Protection System.

Table 1-2 Component Type - Communications Systems Excluding distributed UFLS and distributed UVLS (see Table 3)		
Component Attributes	Maximum Maintenance Interval	Maintenance Activities
Any unmonitored communications system necessary for correct operation of protective functions, and not having all the monitoring attributes of a category below.	4 Calendar Months	Verify that the communications system is functional.
	6 Calendar Years	Verify that the communications system meets performance criteria pertinent to the communications technology applied (e.g. signal level, reflected power, or data error rate). Verify operation of communications system inputs and outputs that are essential to proper functioning of the Protection System.
Any communications system with continuous monitoring or periodic automated testing for the presence of the channel function, and alarming for loss of function (See Table 2).	12 Calendar Years	Verify that the communications system meets performance criteria pertinent to the communications technology applied (e.g. signal level, reflected power, or data error rate). Verify operation of communications system inputs and outputs that are essential to proper functioning of the Protection System.
Any communications system with all of the following: <ul style="list-style-type: none"> • Continuous monitoring or periodic automated testing for the performance of the channel using criteria pertinent to the communications technology applied (e.g. signal level, reflected power, or data error rate, and alarming for excessive performance degradation). (See Table 2) • Some or all binary or status inputs and control outputs are monitored by a process that continuously demonstrates ability to perform as designed, with alarming for failure (See Table 2). 	12 Calendar Years	Verify only the unmonitored communications system inputs and outputs that are essential to proper functioning of the Protection System

Table 1-3 Component Type - Voltage and Current Sensing Devices Providing Inputs to Protective Relays Excluding distributed UFLS and distributed UVLS (see Table 3)		
Component Attributes	Maximum Maintenance Interval	Maintenance Activities
Any voltage and current sensing devices not having monitoring attributes of the category below.	12 Calendar Years	Verify that current and voltage signal values are provided to the protective relays.
Voltage and Current Sensing devices connected to microprocessor relays with <u>acAC</u> measurements <u>that</u> are continuously verified by comparison of sensing input value, as measured by the microprocessor relay, to an independent ac measurement source, with alarming for unacceptable error or failure (see Table 2).	No periodic maintenance specified	None.

Table 1-4(a) Component Type – Protection System Station dc Supply Using Vented Lead-Acid (VLA) Batteries Excluding distributed UFLS and distributed UVLS (see Table 3)		
Protection System Station dc supply used only for non-BES interrupting devices for RAS, non-distributed UFLS systems, or non-distributed UVLS systems is excluded (see Table 1-4(e)).		
Component Attributes	Maximum Maintenance Interval	Maintenance Activities
Protection System Station dc supply using Vented Lead-Acid (VLA) batteries not having monitoring attributes of Table 1-4(f).	4 Calendar Months	Verify: <ul style="list-style-type: none"> • Station dc supply voltage Inspect: <ul style="list-style-type: none"> • Electrolyte level • For unintentional grounds
	18 Calendar Months	Verify: <ul style="list-style-type: none"> • Float voltage of battery charger • Battery continuity • Battery terminal connection resistance • Battery intercell or unit-to-unit connection resistance Inspect: <ul style="list-style-type: none"> • Cell condition of all individual battery cells where cells are visible – or measure battery cell/unit internal ohmic values where the cells are not visible • Physical condition of battery rack

Table 1-4(a) Component Type – Protection System Station dc Supply Using Vented Lead-Acid (VLA) Batteries Excluding distributed UFLS and distributed UVLS (see Table 3)		
Protection System Station dc supply used only for non-BES interrupting devices for RAS, non-distributed UFLS systems, or non-distributed UVLS systems is excluded (see Table 1-4(e)).		
Component Attributes	Maximum Maintenance Interval	Maintenance Activities
	18 Calendar Months -or- 6 Calendar Years	Verify that the station battery can perform as manufactured by evaluating cell/unit measurements indicative of battery performance (e.g. internal ohmic values or float current) against the station battery baseline. -or- Verify that the station battery can perform as manufactured by conducting a performance or modified performance capacity test of the entire battery bank.

Table 1-4(b) Component Type – Protection System Station dc Supply Using Valve-Regulated Lead-Acid (VRLA) Batteries Excluding distributed UFLS and distributed UVLS (see Table 3)		
Protection System Station dc supply used only for non-BES interrupting devices for RAS, non-distributed UFLS systems, or non-distributed UVLS systems is excluded (see Table 1-4(e)).		
Component Attributes	Maximum Maintenance Interval	Maintenance Activities
Protection System Station dc supply with Valve Regulated Lead-Acid (VRLA) batteries not having monitoring attributes of Table 1-4(f).	4 Calendar Months	Verify: <ul style="list-style-type: none"> • Station dc supply voltage Inspect: <ul style="list-style-type: none"> • For unintentional grounds
	6 Calendar Months	Inspect: <ul style="list-style-type: none"> • Condition of all individual units by measuring battery cell/unit internal ohmic values.
	18 Calendar Months	Verify: <ul style="list-style-type: none"> • Float voltage of battery charger • Battery continuity • Battery terminal connection resistance • Battery intercell or unit-to-unit connection resistance Inspect: <ul style="list-style-type: none"> • Physical condition of battery rack

<p style="text-align: center;">Table 1-4(b) Component Type – Protection System Station dc Supply Using Valve-Regulated Lead-Acid (VRLA) Batteries Excluding distributed UFLS and distributed UVLS (see Table 3)</p> <p style="text-align: center;">Protection System Station dc supply used only for non-BES interrupting devices for RAS, non-distributed UFLS systems, or non-distributed UVLS systems is excluded (see Table 1-4(e)).</p>		
Component Attributes	Maximum Maintenance Interval	Maintenance Activities
	6 Calendar Months -or- 3 Calendar Years	Verify that the station battery can perform as manufactured by evaluating cell/unit measurements indicative of battery performance (e.g. internal ohmic values or float current) against the station battery baseline. -or- Verify that the station battery can perform as manufactured by conducting a performance or modified performance capacity test of the entire battery bank.

Table 1-4(c) Component Type – Protection System Station dc Supply Using Nickel-Cadmium (NiCad) Batteries Excluding distributed UFLS and distributed UVLS (see Table 3)		
Protection System Station dc supply used only for non-BES interrupting devices for RAS, non-distributed UFLS system, or non-distributed UVLS systems is excluded (see Table 1-4(e)).		
Component Attributes	Maximum Maintenance Interval	Maintenance Activities
Protection System Station dc supply Nickel-Cadmium (NiCad) batteries not having monitoring attributes of Table 1-4(f).	4 Calendar Months	Verify: <ul style="list-style-type: none"> • Station dc supply voltage Inspect: <ul style="list-style-type: none"> • Electrolyte level • For unintentional grounds
	18 Calendar Months	Verify: <ul style="list-style-type: none"> • Float voltage of battery charger • Battery continuity • Battery terminal connection resistance • Battery intercell or unit-to-unit connection resistance Inspect: <ul style="list-style-type: none"> • Cell condition of all individual battery cells. • Physical condition of battery rack

Table 1-4(c) Component Type – Protection System Station dc Supply Using Nickel-Cadmium (NiCad) Batteries Excluding distributed UFLS and distributed UVLS (see Table 3)		
Protection System Station dc supply used only for non-BES interrupting devices for RAS, non-distributed UFLS system, or non-distributed UVLS systems is excluded (see Table 1-4(e)).		
Component Attributes	Maximum Maintenance Interval	Maintenance Activities
	6 Calendar Years	Verify that the station battery can perform as manufactured by conducting a performance or modified performance capacity test of the entire battery bank.

Table 1-4(d) Component Type – Protection System Station dc Supply Using Non Battery Based Energy Storage Excluding distributed UFLS and distributed UVLS (see Table 3)		
Protection System Station dc supply used only for non-BES interrupting devices for RAS, non-distributed UFLS system, or non-distributed UVLS systems is excluded (see Table 1-4(e)).		
Component Attributes	Maximum Maintenance Interval	Maintenance Activities
Any Protection System station dc supply not using a battery and not having monitoring attributes of Table 1-4(f).	4 Calendar Months	Verify: <ul style="list-style-type: none"> • Station dc supply voltage Inspect: <ul style="list-style-type: none"> • For unintentional grounds
	18 Calendar Months	Inspect: Condition of non-battery based dc supply
	6 Calendar Years	Verify that the dc supply can perform as manufactured when ac power is not present.

Table 1-4(e) Component Type – Protection System Station dc Supply for non-BES Interrupting Devices for RAS, non-distributed UFLS, and non-distributed UVLS systems		
Component Attributes	Maximum Maintenance Interval	Maintenance Activities
Any Protection System dc supply used for tripping only non-BES interrupting devices as part of a RAS, non-distributed UFLS, or non-distributed UVLS system and not having monitoring attributes of Table 1-4(f).	When control circuits are verified (See Table 1-5)	Verify Station dc supply voltage.

Table 1-4(f) Exclusions for Protection System Station dc Supply Monitoring Devices and Systems		
Component Attributes	Maximum Maintenance Interval	Maintenance Activities
Any station dc supply with high and low voltage monitoring and alarming of the battery charger voltage to detect charger overvoltage and charger failure (See Table 2).	No periodic maintenance specified	No periodic verification of station dc supply voltage is required.
Any battery based station dc supply with electrolyte level monitoring and alarming in every cell (See Table 2).		No periodic inspection of the electrolyte level for each cell is required.
Any station dc supply with unintentional dc ground monitoring and alarming (See Table 2).		No periodic inspection of unintentional dc grounds is required.
Any station dc supply with charger float voltage monitoring and alarming to ensure correct float voltage is being applied on the station dc supply (See Table 2).		No periodic verification of float voltage of battery charger is required.
Any battery based station dc supply with monitoring and alarming of battery string continuity (See Table 2).		No periodic verification of the battery continuity is required.
Any battery based station dc supply with monitoring and alarming of the intercell and/or terminal connection detail resistance of the entire battery (See Table 2).		No periodic verification of the intercell and terminal connection resistance is required.
Any Valve Regulated Lead-Acid (VRLA) or Vented Lead-Acid (VLA) station battery with internal ohmic value or float current monitoring and alarming, and evaluating present values relative to baseline internal ohmic values for every cell/unit (See Table 2).		No periodic evaluation relative to baseline of battery cell/unit measurements indicative of battery performance is required to verify the station battery can perform as manufactured.
Any Valve Regulated Lead-Acid (VRLA) or Vented Lead-Acid (VLA) station battery with monitoring and alarming of each cell/unit internal ohmic value (See Table 2).		No periodic inspection of the condition of all individual units by measuring battery cell/unit internal ohmic values of a station VRLA or Vented Lead-Acid (VLA) battery is required.

Table 1-5 Component Type - Control Circuitry Associated With Protective Functions Excluding distributed UFLS and distributed UVLS (see Table 3), Automatic Reclosing (see Table 4), and Sudden Pressure Relaying (see Table 5) Note: Table requirements apply to all Control Circuitry Components of Protection Systems, and RAS except as noted.		
Component Attributes	Maximum Maintenance Interval	Maintenance Activities
Trip coils or actuators of circuit breakers, interrupting devices, or mitigating devices (regardless of any monitoring of the control circuitry).	6 Calendar Years	Verify that each trip coil is able to operate the circuit breaker, interrupting device, or mitigating device.
Electromechanical lockout devices which are directly in a trip path from the protective relay to the interrupting device trip coil (regardless of any monitoring of the control circuitry).	6 Calendar Years	Verify electrical operation of electromechanical lockout devices.
Unmonitored control circuitry associated with RAS. (See Table 4-2(b) for RAS which include Automatic Reclosing.)	12 Calendar Years	Verify all paths of the control circuits essential for proper operation of the RAS.
Unmonitored control circuitry associated with protective functions inclusive of all auxiliary relays.	12 Calendar Years	Verify all paths of the trip circuits inclusive of all auxiliary relays through the trip coil(s) of the circuit breakers or other interrupting devices.
Control circuitry associated with protective functions and/or RAS whose integrity is monitored and alarmed (See Table 2).	No periodic maintenance specified	None.

<p align="center">Table 2 – Alarming Paths and Monitoring</p> <p align="center">In Tables 1-1 through 1-5, Table 3, Tables 4-1 through 4-23, and Table 5 alarm attributes used to justify extended maximum maintenance intervals and/or reduced maintenance activities are subject to the following maintenance requirements</p>		
Component Attributes	Maximum Maintenance Interval	Maintenance Activities
<p>Any alarm path through which alarms in Tables 1-1 through 1-5, Table 3, Tables 4-1 through 4-23, and Table 5 are conveyed from the alarm origin to the location where corrective action can be initiated, and not having all the attributes of the “Alarm Path with monitoring” category below.</p> <p>Alarms are reported within 24 hours of detection to a location where corrective action can be initiated.</p>	12 Calendar Years	Verify that the alarm path conveys alarm signals to a location where corrective action can be initiated.
<p>Alarm Path with monitoring:</p> <p>The location where corrective action is taken receives an alarm within 24 hours for failure of any portion of the alarming path from the alarm origin to the location where corrective action can be initiated.</p>	No periodic maintenance specified	None.

Table 3 Maintenance Activities and Intervals for distributed UFLS and distributed UVLS Systems		
Component Attributes	Maximum Maintenance Interval	Maintenance Activities
Any unmonitored protective relay not having all the monitoring attributes of a category below.	6 Calendar Years	<p>Verify that settings are as specified.</p> <p>For non-microprocessor relays:</p> <ul style="list-style-type: none"> • Test and, if necessary calibrate. <p>For microprocessor relays:</p> <ul style="list-style-type: none"> • Verify operation of the relay inputs and outputs that are essential to proper functioning of the Protection System. • Verify acceptable measurement of power system input values.
<p>Monitored microprocessor protective relay with the following:</p> <ul style="list-style-type: none"> • Internal self-diagnosis and alarming (See Table 2). • Voltage and/or current waveform sampling three or more times per power cycle, and conversion of samples to numeric values for measurement calculations by microprocessor electronics. <p>Alarming for power supply failure (See Table 2).</p>	12 Calendar Years	<p>Verify:</p> <ul style="list-style-type: none"> • Settings are as specified. • Operation of the relay inputs and outputs that are essential to proper functioning of the Protection System. • Acceptable measurement of power system input values.
<p>Monitored microprocessor protective relay with preceding row attributes and the following:</p> <ul style="list-style-type: none"> • Ac measurements are continuously verified by comparison to an independent ac measurement source, with alarming for excessive error (See Table 2). 	12 Calendar Years	<p>Verify only the unmonitored relay inputs and outputs that are essential to proper functioning of the Protection System.</p>

Table 3 Maintenance Activities and Intervals for distributed UFLS and distributed UVLS Systems		
Component Attributes	Maximum Maintenance Interval	Maintenance Activities
<ul style="list-style-type: none"> Some or all binary or status inputs and control outputs are monitored by a process that continuously demonstrates ability to perform as designed, with alarming for failure (See Table 2). Alarming for change of settings (See Table 2).		
Voltage and/or current sensing devices associated with UFLS or UVLS systems.	12 Calendar Years	Verify that current and/or voltage signal values are provided to the protective relays.
Protection System dc supply for tripping non-BES interrupting devices used only for a UFLS or UVLS system.	12 Calendar Years	Verify Protection System dc supply voltage.
Control circuitry between the UFLS or UVLS relays and electromechanical lockout and/or tripping auxiliary devices (excludes non-BES interrupting device trip coils).	12 Calendar Years	Verify the path from the relay to the lockout and/or tripping auxiliary relay (including essential supervisory logic).
Electromechanical lockout and/or tripping auxiliary devices associated only with UFLS or UVLS systems (excludes non-BES interrupting device trip coils).	12 Calendar Years	Verify electrical operation of electromechanical lockout and/or tripping auxiliary devices.
Control circuitry between the electromechanical lockout and/or tripping auxiliary devices and the non-BES interrupting devices in UFLS or UVLS systems, or between UFLS or UVLS relays (with no interposing electromechanical lockout or auxiliary device) and the non-BES interrupting devices (excludes non-BES interrupting device trip coils).	No periodic maintenance specified	None.
Trip coils of non-BES interrupting devices in UFLS or UVLS systems.	No periodic maintenance specified	None.

Table 4-1 Maintenance Activities and Intervals for Automatic Reclosing Components Component Type – Reclosing and Supervisory Relay		
Note: In cases where Components of Automatic Reclosing are common to Components listed in Table 1-1 through 1-5, the Components only need to be tested once during a distinct maintenance interval.		
Component Attributes	Maximum Maintenance Interval	Maintenance Activities
Any unmonitored reclosing relay or supervisory relay not having all the monitoring attributes of a category below.	6 Calendar Years	Verify that settings are as specified. For non-microprocessor reclosing or supervisory relays: <ul style="list-style-type: none"> • Test and, if necessary calibrate For microprocessor reclosing or supervisory relays: <ul style="list-style-type: none"> • Verify operation of the relay inputs and outputs that are essential to proper functioning of the Automatic Reclosing. For microprocessor supervisory relays: <ul style="list-style-type: none"> • Verify acceptable measurement of power system input values.
Monitored microprocessor reclosing relay or supervisory relay with the following: <ul style="list-style-type: none"> • Internal self-diagnosis and alarming (See Table 2). • Alarming for power supply failure (See Table 2). For supervisory relay: <ul style="list-style-type: none"> • Voltage waveform sampling three or more times per power cycle, and conversion of samples to numeric values for measurement calculations by microprocessor electronics. 	12 Calendar Years	Verify: <ul style="list-style-type: none"> • Settings are as specified. Operation of the relay inputs and outputs that are essential to proper functioning of the Automatic Reclosing. For supervisory relays: <ul style="list-style-type: none"> • Verify acceptable measurement of power system input values.

Table 4-1

Maintenance Activities and Intervals for Automatic Reclosing Components

Component Type – Reclosing and Supervisory Relay

Note: In cases where Components of Automatic Reclosing are common to Components listed in Table 1-1 through 1-5, the Components only need to be tested once during a distinct maintenance interval.

<u>Component Attributes</u>	<u>Maximum Maintenance Interval</u>	<u>Maintenance Activities</u>
<p><u>Monitored microprocessor reclosing relay or supervisory relay with preceding row attributes and the following:</u></p> <ul style="list-style-type: none"> • <u>Some or all binary or status inputs and control outputs are monitored by a process that continuously demonstrates ability to perform as designed, with alarming for failure (See Table 2).</u> • <u>Alarming for change of settings (See Table 2).</u> <p><u>For supervisory relay:</u></p> <ul style="list-style-type: none"> • <u>Ac measurements are continuously verified by comparison to an independent Ac measurement source, with alarming for excessive error (See Table 2).</u> 	<p><u>12 Calendar Years</u></p>	<p><u>Verify only the unmonitored relay inputs and outputs that are essential to proper functioning of the Automatic Reclosing.</u></p>

Table 4-2(a)

Maintenance Activities and Intervals for Automatic Reclosing Components

Component Type – Control Circuitry Associated with Reclosing and Supervisory Relays that are NOT an Integral Part of an RAS

Note: In cases where Components of Automatic Reclosing Sudden-Pressure-Relaying are common to Components listed in Table 1-5, the Components only need to be tested once during a distinct maintenance interval.

Component Attributes	Maximum Maintenance Interval	Maintenance Activities
Unmonitored Control circuitry associated with Automatic Reclosing that is not an integral part of an RAS.	12 Calendar Years	Verify that Automatic Reclosing, upon initiation, does not issue a premature closing command to the close circuitry.
Control circuitry associated with Automatic Reclosing that is not part of an RAS and is monitored and alarmed for conditions that would result in a premature closing command. (See Table 2)	No periodic maintenance specified	None.

Table 4-2(b)

Maintenance Activities and Intervals for Automatic Reclosing Components

Component Type – Control Circuitry Associated with Reclosing and Supervisory Relays that ARE an Integral Part of an RAS

Note: In cases where Components of Automatic Reclosing Sudden-Pressure Relaying are common to Components listed in Table 1-5, the Components only need to be tested once during a distinct maintenance interval.

Component Attributes	Maximum Maintenance Interval	Maintenance Activities
Close coils or actuators of circuit breakers or similar devices that are used in conjunction with Automatic Reclosing as part of an RAS (regardless of any monitoring of the control circuitry).	6 Calendar Years	Verify that each close coil or actuator is able to operate the circuit breaker or mitigating device.
Unmonitored close control circuitry associated with Automatic Reclosing used as an integral part of an RAS.	12 Calendar Years	Verify all paths of the control circuits associated with Automatic Reclosing that are essential for proper operation of the RAS.
Control circuitry associated with Automatic Reclosing that is an integral part of an RAS whose integrity is monitored and alarmed. (See Table 2)	No periodic maintenance specified	None.

Table 4-3

Maintenance Activities and Intervals for Automatic Reclosing Components

Component Type – Voltage Sensing Devices Associated with Supervisory Relays

Note: In cases where Components of Automatic Reclosing/Sudden Pressure Relaying are common to Components listed in Table 1-35, the Components only need to be tested once during a distinct maintenance interval.

<u>Component Attributes</u>	<u>Maximum Maintenance Interval</u>	<u>Maintenance Activities</u>
<u>Any voltage sensing devices not having monitoring attributes of the category below.</u>	<u>12 Calendar Years</u>	<u>Verify that voltage signal values are provided to the supervisory relays.</u>
<u>Voltage sensing devices that are connected to microprocessor supervisory relays with acAC measurements that are continuously verified by comparison of sensing input value, as measured by the microprocessor relay, to an independent ac measurement source, with alarming for unacceptable error or failure. (See Table 2)</u>	<u>No periodic maintenance specified</u>	<u>None.</u>

Table 5 Maintenance Activities and Intervals for Sudden Pressure Relaying		
Note: In cases where Components of Sudden Pressure Relaying are common to Components listed in Table 1-5, the Components only need to be tested once during a distinct maintenance interval.		
Component Attributes	Maximum Maintenance Interval	Maintenance Activities
Any fault pressure relay.	6 Calendar Years	Verify the pressure or flow sensing mechanism is operable.
Electromechanical lockout devices which are directly in a trip path from the fault pressure relay to the interrupting device trip coil (regardless of any monitoring of the control circuitry).	6 Calendar Years	Verify electrical operation of electromechanical lockout devices.
Unmonitored control circuitry associated with Sudden Pressure Relaying.	12 Calendar Years	Verify all paths of the trip circuits inclusive of all auxiliary relays through the trip coil(s) of the circuit breakers or other interrupting devices.
Control circuitry associated with Sudden Pressure Relaying whose integrity is monitored and alarmed (See Table 2).	No periodic maintenance specified	None.

PRC-005 — Attachment A

Criteria for a Performance-Based Protection System Maintenance Program

Purpose: To establish a technical basis for initial and continued use of a performance-based Protection System Maintenance Program (PSMP).

To establish the technical justification for the initial use of a performance-based PSMP:

1. Develop a list with a description of Components included in each designated Segment, with a minimum Segment population of 60 Components.
2. Maintain the Components in each Segment according to the time-based maximum allowable intervals established in Tables 1-1 through 1-5, Table 3, Tables 4-1 through 4-~~32~~, and Table 5 until results of maintenance activities for the Segment are available for a minimum of 30 individual Components of the Segment.
3. Document the maintenance program activities and results for each Segment, including maintenance dates and Countable Events for each included Component.
4. Analyze the maintenance program activities and results for each Segment to determine the overall performance of the Segment and develop maintenance intervals.
5. Determine the maximum allowable maintenance interval for each Segment such that the Segment experiences Countable Events on no more than 4% of the Components within the Segment, for the greater of either the last 30 Components maintained or all Components maintained in the previous year.

To maintain the technical justification for the ongoing use of a performance-based PSMP:

1. At least annually, update the list of Components and Segments and/or description if any changes occur within the Segment.
2. Perform maintenance on the greater of 5% of the Components (addressed in the performance based PSMP) in each Segment or 3 individual Components within the Segment in each year.
3. For the prior year, analyze the maintenance program activities and results for each Segment to determine the overall performance of the Segment.
4. Using the prior year's data, determine the maximum allowable maintenance interval for each Segment such that the Segment experiences Countable Events on no more than 4% of the Components within the Segment, for the greater of either the last 30 Components maintained or all Components maintained in the previous year.

If the Components in a Segment maintained through a performance-based PSMP experience 4% or more Countable Events, develop, document, and implement an action plan to reduce the Countable Events to less than 4% of the Segment population within 3 years.

Rationale:

During development of this standard, text boxes were embedded within the standard to explain the rationale for various parts of the standard. Upon BOT approval, the text from the rationale text boxes was moved to this section.

Alignment of PRC-005 Compliance Dates

I. PRC-005 Compliance Issue and Proposal to Align Compliance Dates

Since the approval of PRC-005-2, a number of standards development projects have resulted in either including or excluding devices from the scope of PRC-005. Currently, there are eight approved or currently proposed PRC-005 versions, and each Version comes with a separate implementation schedule. Version PRC-005-2(i) is the current mandatory and enforceable version as of the date of this posting. Depending on the type of device and specific requirement in some of the PRC-005 versions, the implementation is divided into phases, requiring registered entities to gradually ensure compliance of a percentage of their devices until they reach 100% compliance.

Versions -3, -4, and -6 will require three consecutive updates to the registered entities' Protection System Maintenance Programs (PSMP), which is expected to be a time-consuming task for many entities. Based on the implementation plans for these three versions, the required PSMP updates would have to be completed within one (1) year to eighteen (18) months. According to the PRC-005 drafting team, which represents various industry members, this short period of time for review and identification of all assets subject to the revised PRC-005 versions could lead to errors and misidentification of devices. Further, the existence of eight implementation plans could lead to misinterpretations and inconsistencies in the compliance and auditing practices throughout the Electric Reliability Organization (ERO) Enterprise.

To address this compliance issue, the PRC-005 drafting team requested that NERC align the effective dates of all outstanding PRC-005 Versions, thus simplifying the implementation schedule for this Reliability Standard. In response to the drafting team's request, NERC plans to petition the Federal Energy Regulatory Commission (FERC) to delay the implementation of approved versions PRC-005-3 and PRC-005-4. Because PRC-005-6 reflects the new applicability that has been introduced by PRC-005-2(ii), PRC-005-3, PRC-005-3(i), PRC-005-3(ii), PRC-005-4, PRC-005-5, and PRC-005-6, when PRC-005-6 becomes effective, all new applicability will become effective and aligned to the same dates. NERC proposes that the phased in implementation of PRC-005-2 continue in accordance with the PRC-005-2 implementation plan, which is incorporated by reference into the implementation plan for currently-effective PRC-005-2(i). The phased implementation approach will remain but the effective dates for each phase will align applicability.

This proposal is reflected in the implementation plan for PRC-005-6. If supported by industry members and adopted by the NERC Board of Trustees, the implementation plan will be included in the PRC-005-6 petition to be filed with FERC for approval.

II. PRC-005 Versions Overview

The draft PRC-005-6 incorporates all revisions made to PRC-005-2 as a result of the development of PRC-005-2(i) (the currently-effective version), PRC-005-2(ii), PRC-005-3, PRC-005-3(i), PRC-005-3(ii), PRC-005-4, and PRC-005-5, and PRC-005-6. Version -3 added Automatic Reclosing devices; versions 2(i), 3(i), and -5 exclude individual dispersed generation resources from the applicability of the standard; versions 2(ii) and 3(ii) replace the term "Special Protection System" with the term "Remedial Action Scheme"; version -4 added Sudden Pressure Relays; and version -6 will add supervisory relays and exclude individual dispersed generation resources from the applicability of this Reliability Standard.

From this list of all PRC-005 versions, versions 2(i), 3, 3(i), and 4 are approved by FERC; PRC-005-2(ii) and PRC-005-3(ii) are pending regulatory approval; PRC-005-5 has not yet been filed for approval with FERC; and PRC-005-6 is currently under development.

III. Impact on the Reliability of the Bulk Power System and on Compliance with PRC-005

Based on the implementation schedule for the FERC-approved PRC-005-3, PRC-005-3(i), and PRC-005-4, and estimated approval and effective dates for the remaining versions, the delay in the implementation of PRC-005-3 and PRC-005-4 created by this proposal is anticipated to be approximately one year.

The proposed changes described here and in the proposed PRC-005-6 implementation plan will not affect the immediate implementation of version 2(i). This version excludes certain dispersed generation resources from the definition of Bulk Electric System, and from the applicability of PRC-005. Thus, registered entities that own and operate dispersed generation resources will remain unaffected by the proposed changes.

PRC-005-2(ii) and PRC-005-3(ii), which as of this writing are pending before the Commission, reflect enhancements to the NERC Glossary of Terms related to Special Protection Systems and Remedial Action Schemes. A potential delay in implementation of the revised definition of Remedial Action Scheme would not present a risk to the reliability of the Bulk Power System (BPS). Finally, the anticipated changes related to Remedial Action Schemes are minor in nature and are unlikely to introduce an actual reliability risk.

Because the Automatic Reclosing devices and Sudden Pressure Relays brought in by versions -3 and -4 are limited in scope, a potential delay in the implementation of these versions of PRC-005 is also unlikely to increase risk to the BPS. Many of these devices are already monitored by industry in anticipation of the upcoming compliance requirements, but may not be specifically included in the registered entities' PSMPs at this time.

IV. Benefits to Registered Entities

The proposal aims to simplify the compliance efforts of all registered entities subject to PRC-005 and give industry additional time to comply with versions -3, -4, and -6, which require PSMP updates. Having PRC-005-2(ii), PRC-005-3, PRC-005-3(i), PRC-005-3(ii), PRC-005-4, PRC-005-5, and PRC-005-6 essentially become effective at the same time through a single, unified PRC-005-6 Reliability Standard and associated implementation plan minimizes the possibility of misinterpretations of multiple PRC-005 versions and associated compliance obligations, thus limiting the compliance risk for registered entities. In addition, the proposed changes will not affect the anticipated exclusion of certain dispersed generation resources from the scope of the standard.

To further facilitate compliance, NERC plans to use the additional time until PRC-005-6 becomes effective to conduct outreach and provide training to ensure that registered entities are well aware and prepared to meet their obligations under the various PRC-005 versions.

Effective Date Information

Table 1 provides information regarding each version of the PRC-005 standard.

Table 1: PRC-005 Effective Date Information		
Standard	Effective Date ¹	Comments
PRC-005-2	April 1, 2015	
PRC-005-2(i)	May 29, 2015	Proposed effective date with version 2, which was immediately following FERC approval.
PRC-005-2(ii)	Filed and Pending Regulatory Approval	Proposed to be deferred; will be replaced with version 6. ²
PRC-005-3	April 1, 2016	Proposed to be deferred; will be replaced with version 6.
PRC-005-3(i)	April 1, 2016	Proposed to be deferred; will be replaced with version 6.
PRC-005-3(ii)	Filed and Pending Regulatory Approval	Proposed to be deferred; will be replaced with version 6.
PRC-005-4	January 1, 2016	Proposed to be deferred; will be replaced with version 6.
PRC-005-5	Pending Regulatory Filing	Proposed to be deferred; will be replaced with version 6.
PRC-005-6	Pending Regulatory Filing	TBD

¹ The effective date listed is the start date of when the standard becomes effective. This does not include the phased in approach.

² The effective date is dependent on when FERC approves PRC-005-6, which could be from three (3) months to one (1) year after submittal of the petition for approval.

Implementation Plan

Project 2007-17.4 PRC-005 FERC Order No. 803 Directive
PRC-005-6

Standards Involved

Approval:

- PRC-005-6 – Protection System, Automatic Reclosing, and Sudden Pressure Relaying Maintenance

Retirement:

- PRC-005-5 – Protection System, Automatic Reclosing, and Sudden Pressure Relaying Maintenance
- PRC-005-4 Protection System, Automatic Reclosing, and Sudden Pressure Relaying Maintenance
- PRC-005-3 (ii) Protection System and Automatic Reclosing Maintenance
- PRC-005-3 (i) Protection System and Automatic Reclosing Maintenance
- PRC-005-3 Protection System and Automatic Reclosing Maintenance
- PRC-005-2 (ii) Protection System Maintenance
- PRC-005-2 (i) Protection System Maintenance
- ~~PRC-005-2 Protection System Maintenance~~
- PRC-005-1.1b – Transmission and Generation Protection System Maintenance and Testing
- PRC-008-0 – Implementation and Documentation of Underfrequency Load Shedding Equipment Maintenance Program
- PRC-011-0 – Undervoltage Load Shedding System Maintenance and Testing
- PRC-017-0 – Special Protection System Maintenance and Testing

Prerequisite Approvals:

N/A

Background:

In Order No. 803, FERC approved Standard PRC-005-3 and, in Paragraph 31, directed NERC to:

"...develop modifications to PRC-005-3 to include supervisory devices associated with auto-reclosing relay schemes to which the Reliability Standard applies. Further, we clarify that NERC's proposal regarding the scope of supervisory devices is an acceptable approach to satisfy the Commission directive. Specifically, NERC proposed in its NOPR comments, and we find acceptable, that the scope of the supervisory devices to be encompassed in the Reliability Standard are those providing voltage supervision, supervisory inputs associated with selective auto-reclosing, and sync-check relays that are part of a reclosing scheme covered by PRC-005-3."

This Implementation Plan addresses:

- The implementation of changes relating to maintenance and testing of supervisory relays and associated voltage sensing devices related to Automatic Reclosing.
- The phased implementation approach included in the approved PRC-005-2(i) (~~PRC-005-2 has been retired by PRC-005-2(ii) and proposed PRC-005-2(i) will remain as-is and is carried forward and incorporated by reference.~~) will remain as-is and is carried forward and incorporated by reference.
- ~~Because PRC-005-6 incorporates all revisions to date, This implementation schedule lays out the implementation timeline for the currently effective PRC-005-2 and proposed PRC-005-2(i), and combines the implementation plans for the approved PRC-005-3 and all subsequent pending PRC-005 versions (PRC-005-2(ii), PRC-005-3(i), PRC-005-3(ii), PRC-005-4 and PRC-005-5), making all versions from PRC-005-3 onwards effective on the same day PRC-005-6 becomes effective. The effective dates for the various phases specified in PRC-005-3 and each subsequent version of PRC-005 will align with the effective dates for those phases included in the PRC-005-6 Implementation Plan. For the pending versions that do not entail phased implementation, the versions will become effective on the date PRC-005-6 first becomes effective.~~
- ~~Notwithstanding any order to the contrary, this implementation plan will supersede the implementation plans for~~ PRC-005-2(ii), PRC-005-3, PRC-005-3(i), PRC-005-3(ii), PRC-005-4 and PRC-005-5 when PRC-005-6 becomes effective. will not become effective, and PRC-005-2(i) will remain in effect and not be retired until- entities are required to be compliant with R1, R2, and R5 of the the effective date of the PRC-005-6 standard under this implementation plan.⁴

The Implementation Plan reflects consideration of the following:

⁴In jurisdictions where previous versions of PRC-005 have not yet become effective according to their implementation plans (even if approved by order), this implementation plan and the PRC-005-6 standard supersedes and replaces the implementation plans and standards for PRC-005-2(i), PRC-005-2(ii), PRC-005-3, PRC-005-3(i), PRC-005-3(ii), PRC-005-4, and PRC-005-5.

1. The requirements set forth in the proposed standard, which carry forward requirements from PRC-005-2, PRC-005-2(i), PRC-005-2(ii), PRC-005-3, PRC-005-3(i), PRC-005-3(ii), PRC-005-4 and PRC-005-5, establish minimum maintenance activities for Protection System, Automatic Reclosing, and Sudden Pressure Relaying Component Types as well as the maximum allowable maintenance intervals for these maintenance activities.
2. The maintenance activities established in the various PRC-005 versions may not be presently performed by some registered entities and the established maximum allowable intervals may be shorter than those currently in use by some entities. Therefore, registered entities may not be presently performing a maintenance activity or may be using longer intervals than the maximum allowable intervals established in the PRC-005 standards. For these registered entities, it is unrealistic to become immediately compliant with the new activities or intervals. Further, registered entities should be allowed to become compliant in such a way as to facilitate a continuing PRC-005 maintenance program. The registered entities that have previously been performing maintenance within the newly specified intervals may not have all the documentation needed to demonstrate compliance with all of the maintenance activities specified.
3. The implementation schedule set forth below carries forward and incorporates by reference the implementation schedules contained in the currently effective version of PRC-005-2(i) and proposed (currently-effective PRC-005-2(i) implementation plan (which in turn incorporates by reference the PRC-005-2 implementation plan)), and combines the implementation schedules for PRC-005-2(ii), PRC-005-3, PRC-005-3(i), PRC-005-3(ii), PRC-005-4 and PRC-005-5. In addition, the implementation schedule includes changes needed to address the addition of Automatic Reclosing supervisory relays and associated voltage sensing devices in PRC-005-6.

General Considerations:

Each Transmission Owner, Generator Owner, and Distribution Provider shall maintain documentation to demonstrate compliance with PRC-005-1.1b, PRC-008-0, PRC-011-0, and PRC-017-0 until that entity meets all of the requirements of the currently effective PRC-005-2(i), or its combined successor standards, in accordance with this implementation Plan.

While registered entities are implementing the requirements of PRC-005-2(i) or its combined successor standards, each registered entity must be prepared to identify:

~~All of its applicable Protection System, Automatic Reclosing, and Sudden Pressure Relaying Components, and~~

~~whether its applicable Protection System, Automatic Reclosing, and Sudden Pressure Relaying Components each component has were~~ last ~~been~~ maintained according to PRC-005-2(i) (or its combined successor standards), PRC-005-1.1b, PRC-008-0, PRC-011-0, PRC-017-0, or a combination thereof.

Effective Date

PRC-005-6 shall become effective on the first day of the first calendar quarter after the date that the standard is approved by an applicable governmental authority or as otherwise provided for in a jurisdiction where approval by an applicable governmental authority is required for a standard to go into effect. Where approval by an applicable governmental authority is not required, the standard shall become effective on the first day of the first calendar quarter after the date the standard is adopted by the NERC Board of Trustees or as otherwise provided for in that jurisdiction.

Retirement of Existing Standards:

Standards PRC-005-1.1b, PRC-008-0, PRC-011-0, and PRC-017-0 shall remain ~~active-enforceable~~ throughout the phased implementation period ~~of set forth in the~~ [PRC-005-2\(i\) implementation plan, incorporated herein by reference](#), and shall be applicable to a registered entity's Protection System Component maintenance activities not yet transitioned to ~~PRC-005-2(i) or its combined successor standards~~. Standards PRC-005-1.1b, PRC-008-0, PRC-011-0, and PRC-017-0 shall be retired at midnight of March 31, 2027 or as otherwise made effective pursuant to the laws applicable to such Electric Reliability Organization (ERO) governmental authorities; or, in those jurisdictions where no regulatory approval is required, at midnight of March 31, 2027.

~~PRC-005-2 and~~ PRC-005-2(i) shall be retired at midnight of the day immediately prior to the first day of the first calendar quarter ~~that is,~~ twelve (12) calendar months following applicable regulatory approval of PRC-005-6, or as otherwise made effective pursuant to the laws applicable to such ERO governmental authorities; or, in those jurisdictions where no regulatory approval is required, the first day of the first calendar quarter ~~from following~~ the date of Board of Trustees' adoption.

If approved by ~~FERC~~ [the applicable ERO governmental authority](#) prior to the approval of PRC-005-6, PRC-005-2(ii), PRC-005-3, PRC-005-3(i), PRC-005-3(ii), PRC-005-4 and PRC-005-5 shall be retired on the date immediately prior to the first day of the first calendar quarter following regulatory approval of PRC-005-6.

Implementation Plan for Definitions:

This section includes all newly defined or revised terms used in the proposed standard. Terms already defined in the Reliability Standards Glossary of Terms (Glossary) are not repeated here. New or revised definitions listed below become approved when the proposed standard is approved by applicable governmental authority or as otherwise provided for in a jurisdiction where approval by an applicable governmental authority is required for a standard to go into effect. When the standard becomes effective, the Glossary definition will be removed from the individual standard and added to the Glossary. The definitions of terms used only in the standard will remain in the standard.

Glossary Definition:

NoneProtection System Maintenance Program (PSMP) - An ongoing program by which Protection System, Automatic Reclosing, and Sudden Pressure Relaying Components are kept in working order and proper operation of malfunctioning Components is restored. A maintenance program for a specific Component includes one or more of the following activities:

- Verify — Determine that the Component is functioning correctly.
- Monitor — Observe the routine in-service operation of the Component.
- Test — Apply signals to a Component to observe functional performance or output behavior, or to diagnose problems.
- Inspect — Examine for signs of Component failure, reduced performance or degradation.
- Calibrate — Adjust the operating threshold or measurement accuracy of a measuring element to meet the intended performance requirement.

Definitions of Terms Used in the Standard:

Automatic Reclosing – Includes the following Components:

- Reclosing relay
- Supervisory relay(s) or function(s) – relay(s) or function(s) that perform voltage and/or sync check functions that enable or disable operation of the reclosing relay
- Voltage sensing devices associated with the supervisory relay(s)
- Control circuitry associated with the reclosing relay or supervisory relay(s)

Component Type –

- Any one of the five specific elements of a Protection System.
- Any one of the four specific elements of Automatic Reclosing.
- Any one of the two specific elements of Sudden Pressure Relaying.

Component – Any individual discrete piece of equipment included in a Protection System, Automatic Reclosing, or Sudden Pressure Relaying.

Countable Event – A failure of a Component requiring repair or replacement, any condition discovered during the maintenance activities in Tables 1-1 through 1-5, Table 3, Tables 4-1 through 4-3, and Table 5, which requires corrective action or a Protection System Misoperation attributed to hardware failure or calibration failure. Misoperations due to product design errors, software errors, relay settings different from specified settings, Protection System

Component, Automatic Reclosing, or Sudden Pressure Relaying configuration or application errors are not included in Countable Events.

Sudden Pressure Relaying - A system that trips an interrupting device(s) to isolate the equipment it is monitoring and includes the following Components:

- Fault pressure relay – a mechanical relay or device that detects rapid changes in gas pressure, oil pressure, or oil flow that are indicative of Faults within liquid-filled, wire-wound equipment
- Control circuitry associated with a fault pressure relay

Implementation Plan for New or Revised Definitions:

The revised definitions (Protection System Maintenance Program, Automatic Reclosing, Component Type, Component, and Countable Event and Sudden Pressure Relaying) become effective upon the effective date of PRC-005-6.

Implementation Plan for PRC-005-2(i) and PRC-005-6

All Components with existing requirements under PRC-005-2 and currently effective PRC-005-2(i) will continue to follow the PRC-005-2(i) implementation plan, which is incorporated herein by reference. Those Components and/or Facilities newly introduced by PRC-005-2(ii),* PRC-005-3, PRC-005-3(i), PRC-005-3(ii),* PRC-005-4, PRC-005-5 and PRC-005-6 (including Sudden Pressure Relaying, Automatic Reclosing Components, and Dispersed Generation Resources) will be covered by the following Implementation Plan:

Requirements R1, R2, and R5:

PRC-005-6: For Automatic Reclosing Components, Sudden Pressure Relaying Components, and Dispersed Generation Resources, entities shall be 100% compliant on the first day of the first calendar quarter twelve (12) months following applicable regulatory approvals of PRC-005-6 or, in those jurisdictions where no regulatory approval is required, on the first day of the first calendar quarter twenty-four (24) months following NERC Board of Trustees' adoption of PRC-005-6 or as otherwise made effective pursuant to the laws applicable to such ERO governmental authorities.

Implementation Plan for Requirements R3 and R4:

PRC-005-6:

*The proposed Implementation Plan for the Revised Definition of "Remedial Action Scheme" developed as part of Project 2010-05.2 – Special Protection Systems shall continue to govern implementation of the revised Remedial Action Scheme definition, including implementation for entities with newly classified "Remedial Action Scheme."

1. For Automatic Reclosing Components, Sudden Pressure Relaying Components, and ~~D~~ispersed ~~G~~eneration ~~R~~esources maintenance activities with maximum allowable intervals of six (6) calendar years, as established in Tables 4-1, 4-2(a), 4-2(b), 4-3, and 5:
 - The entity shall be at least 30% compliant on the first day of the first calendar quarter thirty-six (36) months following applicable regulatory approval of PRC-005-6 (or, for generating plants with scheduled outage intervals exceeding three years, at the conclusion of the first succeeding maintenance outage) or, in those jurisdictions where no regulatory approval is required, on the first day of the first calendar quarter forty-eight (48) months following NERC Board of Trustees' adoption of PRC-005-6 or as otherwise made effective pursuant to the laws applicable to such ERO governmental authorities.
 - The entity shall be at least 60% compliant on the first day of the first calendar quarter sixty (60) months following applicable regulatory approval of PRC-005-6 or, in those jurisdictions where no regulatory approval is required, on the first day of the first calendar quarter seventy-two (72) months following NERC Board of Trustees' adoption of PRC-005-6, or as otherwise made effective pursuant to the laws applicable to such ERO governmental authorities.
 - The entity shall be 100% compliant on the first day of the first calendar quarter eighty-four (84) months following applicable regulatory approval of PRC-005-6 or, in those jurisdictions where no regulatory approval is required, on the first day of the first calendar quarter ninety-six (96) months following NERC Board of Trustees' adoption of PRC-005-6 or as otherwise made effective pursuant to the laws applicable to such ERO governmental authorities.
2. For Automatic Reclosing Components, Sudden Pressure Relaying Components, and ~~D~~ispersed ~~G~~eneration ~~R~~esources maintenance activities, with maximum allowable intervals of twelve (12) calendar years, as established in Table 4-1, 4.2(a), 4.2(b), 4-3, and 5:
 - The entity shall be at least 30% compliant on the first day of the first calendar quarter sixty (60) months following applicable regulatory approval of PRC-005-6 or, in those jurisdictions where no regulatory approval is required, on the first day of the first calendar quarter seventy-two (72) months following NERC Board of Trustees' adoption of PRC-005-6 or as otherwise made effective pursuant to the laws applicable to such ERO governmental authorities.
 - The entity shall be at least 60% compliant on the first day of the first calendar quarter following one hundred eight (108) months following applicable regulatory approval of PRC-005-6 or, in those jurisdictions where no regulatory approval is required, on the first day of the first calendar quarter one hundred twenty (120) months following NERC Board of Trustees' adoption of PRC-005-6 or as otherwise made effective pursuant to the laws applicable to such ERO governmental authorities.
 - The entity shall be 100% compliant on the first day of the first calendar quarter one hundred fifty-six (156) months following applicable regulatory approval of PRC-005-6 or, in those jurisdictions where no regulatory approval is required, on the first day of the first calendar quarter one hundred sixty-eight (168) months following NERC Board of Trustees' adoption of

PRC-005-6 or as otherwise made effective pursuant to the laws applicable to such ERO governmental authorities.

Applicability:

This standard applies to the following functional entities:

- Transmission Owner
- Generator Owner
- Distribution Provider

Alignment of PRC-005 Compliance Dates

I. PRC-005 Compliance Issue and Proposal to Align Compliance Dates

Since the approval of PRC-005-2, a number of standards development projects have resulted in either including or excluding devices from the scope of PRC-005. Currently, there are eight approved or currently proposed PRC-005 versions, and each Version comes with a separate implementation schedule. Version PRC-005-2(i) is the current mandatory and enforceable version as of the date of this posting. Depending on the type of device and specific requirement in some of the PRC-005 versions, the implementation is divided into phases, requiring registered entities to gradually ensure compliance of a percentage of their devices until they reach 100% compliance.

Versions -3, -4, and -6 will require three consecutive updates to the registered entities' Protection System Maintenance Programs (PSMP), which is expected to be a time-consuming task for many entities. Based on the implementation plans for these three versions, the required PSMP updates would have to be completed within one (1) year to eighteen (18) months. According to the PRC-005 drafting team, which represents various industry members, this short period of time for review and identification of all assets subject to the revised PRC-005 versions could lead to errors and misidentification of devices. Further, the existence of eight implementation plans could lead to misinterpretations and inconsistencies in the compliance and auditing practices throughout the Electric Reliability Organization (ERO) Enterprise.

To address this compliance issue, the PRC-005 drafting team requested that NERC align the effective dates of all outstanding PRC-005 Versions, thus simplifying the implementation schedule for this Reliability Standard. In response to the drafting team's request, NERC plans to petition the Federal Energy Regulatory Commission (FERC) to delay the implementation of approved versions PRC-005-3 and PRC-005-4. Because PRC-005-6 reflects the new applicability that has been introduced by PRC-005-2(ii), PRC-005-3, PRC-005-3(i), PRC-005-3(ii), PRC-005-4, PRC-005-5, and PRC-005-6, when PRC-005-6 becomes effective, all new applicability will become effective and aligned to the same dates. NERC proposes that the phased in implementation of PRC-005-2 continue in accordance with the PRC-005-2 implementation plan, which is incorporated by reference into the implementation plan for currently-effective PRC-005-2(i). The phased implementation approach will remain but the effective dates for each phase will align applicability.

This proposal is reflected in the implementation plan for PRC-005-6. If supported by industry members and adopted by the NERC Board of Trustees, the implementation plan will be included in the PRC-005-6 petition to be filed with FERC for approval.

II. PRC-005 Versions Overview

The draft PRC-005-6 incorporates all revisions made to PRC-005-2 as a result of the development of PRC-005-2(i) (the currently-effective version), PRC-005-2(ii), PRC-005-3, PRC-005-3(i), PRC-005-3(ii), PRC-005-4, and PRC-005-5, and PRC-005-6. Version -3 added Automatic Reclosing devices; versions 2(i), 3(i), and -5 exclude individual dispersed generation resources from the applicability of the standard; versions 2(ii) and 3(ii) replace the term "Special Protection System" with the term "Remedial Action Scheme"; version -4 added Sudden Pressure Relays; and version -6 will add supervisory relays and exclude individual dispersed generation resources from the applicability of this Reliability Standard.

From this list of all PRC-005 versions, versions 2(i), 3, 3(i), and 4 are approved by FERC; PRC-005-2(ii) and PRC-005-3(ii) are pending regulatory approval; PRC-005-5 has not yet been filed for approval with FERC; and PRC-005-6 is currently under development.

III. Impact on the Reliability of the Bulk Power System and on Compliance with PRC-005

Based on the implementation schedule for the FERC-approved PRC-005-3, PRC-005-3(i), and PRC-005-4, and estimated approval and effective dates for the remaining versions, the delay in the implementation of PRC-005-3 and PRC-005-4 created by this proposal is anticipated to be approximately one year.

The proposed changes described here and in the proposed PRC-005-6 implementation plan will not affect the immediate implementation of version 2(i). This version excludes certain dispersed generation resources from the definition of Bulk Electric System, and from the applicability of PRC-005. Thus, registered entities that own and operate dispersed generation resources will remain unaffected by the proposed changes.

PRC-005-2(ii) and PRC-005-3(ii), which as of this writing are pending before the Commission, reflect enhancements to the NERC Glossary of Terms related to Special Protection Systems and Remedial Action Schemes. A potential delay in implementation of the revised definition of Remedial Action Scheme would not present a risk to the reliability of the Bulk Power System (BPS). Finally, the anticipated changes related to Remedial Action Schemes are minor in nature and are unlikely to introduce an actual reliability risk.

Because the Automatic Reclosing devices and Sudden Pressure Relays brought in by versions -3 and -4 are limited in scope, a potential delay in the implementation of these versions of PRC-005 is also unlikely to increase risk to the BPS. Many of these devices are already monitored by industry in anticipation of the upcoming compliance requirements, but may not be specifically included in the registered entities' PSMPs at this time.

IV. Benefits to Registered Entities

The proposal aims to simplify the compliance efforts of all registered entities subject to PRC-005 and give industry additional time to comply with versions -3, -4, and -6, which require PSMP updates. Having PRC-005-2(ii), PRC-005-3, PRC-005-3(i), PRC-005-3(ii), PRC-005-4, PRC-005-5, and PRC-005-6 essentially become effective at the same time through a single, unified PRC-005-6 Reliability Standard and associated implementation plan minimizes the possibility of misinterpretations of multiple PRC-005 versions and associated compliance obligations, thus limiting the compliance risk for registered entities. In addition, the proposed changes will not affect the anticipated exclusion of certain dispersed generation resources from the scope of the standard.

To further facilitate compliance, NERC plans to use the additional time until PRC-005-6 becomes effective to conduct outreach and provide training to ensure that registered entities are well aware and prepared to meet their obligations under the various PRC-005 versions.

Effective Date Information

Table 1 provides information regarding each version of the PRC-005 standard.

Table 1: PRC-005 Effective Date Information		
Standard	Effective Date ¹	Comments
PRC-005-2	April 1, 2015	
PRC-005-2(i)	May 29, 2015	Proposed effective date with version 2, which was immediately following FERC approval.
PRC-005-2(ii)	Filed and Pending Regulatory Approval	Proposed to be deferred; will be replaced with version 6. ²
PRC-005-3	April 1, 2016	Proposed to be deferred; will be replaced with version 6.
PRC-005-3(i)	April 1, 2016	Proposed to be deferred; will be replaced with version 6.
PRC-005-3(ii)	Filed and Pending Regulatory Approval	Proposed to be deferred; will be replaced with version 6.
PRC-005-4	January 1, 2016	Proposed to be deferred; will be replaced with version 6.
PRC-005-5	Pending Regulatory Filing	Proposed to be deferred; will be replaced with version 6.
PRC-005-6	Pending Regulatory Filing	TBD

¹ The effective date listed is the start date of when the standard becomes effective. This does not include the phased in approach.

² The effective date is dependent on when FERC approves PRC-005-6, which could be from three (3) months to one (1) year after submittal of the petition for approval.

Alignment of PRC-005 Compliance Dates

I. PRC-005 Compliance Issue and Proposal to Align Compliance Dates

Since the approval of PRC-005-2 ~~which is currently mandatory and enforceable~~, a number of standards development projects have resulted in either including or excluding devices from the scope of PRC-005. Currently, there are eight approved or currently proposed PRC-005 versions, and each Version comes with a separate implementation schedule. ~~Version PRC-005-2(i) is the current mandatory and enforceable version as of the date of this posting.~~ Depending on the type of device and specific requirement in some of the PRC-005 versions, the implementation is divided into phases, requiring registered entities to gradually ensure compliance of a percentage of their devices until they reach 100% compliance.

Versions -3, -4, and -6 will require three consecutive updates to the registered entities' Protection System Maintenance Programs (PSMP), which is expected to be a time-consuming task for many entities. Based on the implementation plans for these three versions, the required PSMP updates would have to be completed within one (1) year to eighteen (18) months. According to the PRC-005 drafting team, which represents various industry members, this short period of time for review and identification of all assets subject to the revised PRC-005 versions could lead to errors and misidentification of devices. Further, the existence of eight implementation plans could lead to misinterpretations and inconsistencies in the compliance and auditing practices throughout the Electric Reliability Organization (ERO) Enterprise.

To address this compliance issue, the PRC-005 drafting team requested that NERC align the effective dates of all outstanding PRC-005 Versions, thus simplifying the implementation schedule for this Reliability Standard. In response to the drafting team's request, NERC plans to petition the Federal Energy Regulatory Commission (FERC) to delay the implementation of approved versions PRC-005-3 and PRC-005-4. Because PRC-005-6 reflects the new applicability that has been introduced by and have PRC-005-2(ii), PRC-005-3, PRC-005-3(i), PRC-005-3(ii), PRC-005-4, PRC-005-5, and PRC-005-6, when PRC-005-6 becomes effective, all new applicability will become effective and aligned to the same dates. ~~all become effective on the same date.~~ NERC is also proposing that the implementation of PRC-005-2(i) is aligned with the currently effective PRC-005-2. NERC proposes that the phased in implementation of PRC-005-2 continue in accordance with the PRC-005-2 implementation plan, which is incorporated by reference into the implementation plan for currently-effective PRC-005-2(i).The phased implementation approach will remain but the effective dates for each phase will align ~~across all applicability e-versions.~~

This proposal is reflected in the implementation plan for PRC-005-6. If supported by industry members and adopted by the NERC Board of Trustees, the implementation plan will be included in the PRC-005-6 petition to be filed with FERC for approval review.

II. PRC-005 Versions Overview

The draft PRC-005-6 incorporates all revisions made to PRC-005-2~~(i)~~ as a result of the development of PRC-005-2(i), PRC-005-2(i) (the currently-effective version), PRC-005-2(ii), PRC-005-3, PRC-005-3(i), PRC-005-3(ii), PRC-005-4, and PRC-005-5, and PRC-005-6. Version -3 added Automatic Reclosing devices; versions 2(i), 2(i),3(i), and -5 exclude individual dispersed generation resources from the applicability of the standard; versions 2(ii) and 3(ii) replace the term "Special Protection System" with the term

“Remedial Action Scheme”; version -4 added Sudden Pressure Relays; and version -6 will add supervisory relays and exclude individual dispersed generation resources from the applicability of this Reliability Standard.

From this list of all PRC-005 versions, versions 2(i), 3, 3(i), and 4 are approved by FERC; ~~PRC-005-2(i), PRC-005-2(ii), PRC-005-3(i), and PRC-005-3(ii), and PRC-005-4~~ are pending regulatory approval; PRC-005-5 has not yet been filed for approval with FERC; and PRC-005-6 is currently under development.

III. Impact on the Reliability of the Bulk Power System and on Compliance with PRC-005

Based on the implementation schedule for the FERC-approved PRC-005-3, PRC-005-3(i), and PRC-005-4, and estimated approval and effective dates for the remaining versions, the delay in the implementation of PRC-005-3 and PRC-005-4 created by this proposal is anticipated to be approximately one year.

The proposed changes described here and in the proposed PRC-005-6 implementation plan will not affect the immediate implementation of versions ~~2(i), 3(i), and -5~~. ~~These~~ This versions ~~excludes~~ certain dispersed generation resources from the definition of Bulk Electric System, and from the applicability of PRC-005. Thus, registered entities that own and operate dispersed generation resources will remain unaffected by the proposed changes.

PRC-005-2(ii) and PRC-005-3(ii), which as of this writing are pending before the Commission, reflect enhancements to the NERC Glossary of Terms related to Special Protection Systems and Remedial Action Schemes. ~~While alignment between the standards and the Glossary of Terms is important, A potential delays in this implementation of the revised definition of Remedial Action Scheme alignment would not present a risk to the reliability of the Bulk Power System (BPS). The petition requesting changes to PRC-005-2(ii) and PRC-005-3(ii) is pending and its review will likely be delayed until the Commission reviews the petition for PRC-010-1 related to Under Voltage Load Shedding Program.~~ Finally, the anticipated changes related to Remedial Action Schemes are minor in nature and are unlikely to introduce an actual reliability risk.

Because the Automatic Reclosing devices and Sudden Pressure Relays brought in by versions -3 and -4 are limited in scope, a potential delay in the implementation of these versions of PRC-005 is also unlikely to increase risk to the BPS. Many of these devices are already monitored by industry in anticipation of the upcoming compliance requirements, but may not be specifically included in the registered entities' PSMPs at this time.

IV. Benefits to Registered Entities

The proposal aims to simplify the compliance efforts of all registered entities subject to PRC-005 and give industry additional time to comply with versions -3, -4, and -6, which require PSMP updates. Having PRC-005-2(ii), PRC-005-3, PRC-005-3(i), PRC-005-3(ii), PRC-005-4, ~~and PRC-005-5, and~~ PRC-005-6 essentially become effective at the same time through a single, unified PRC-005-6 Reliability Standard and associated implementation plan minimizes the possibility of misinterpretations of ~~each multiple~~ PRC-005 versions and associated compliance obligations, thus limiting the compliance risk for registered entities. In addition, the proposed changes will not affect the anticipated exclusion of certain dispersed generation resources from the scope of the standard.

To further facilitate compliance, NERC plans to use the additional time until PRC-005-6 becomes effective to conduct outreach and provide training to ensure that registered entities are well aware and prepared to meet their obligations under the various PRC-005 versions.

Effective Date Information

Table 1 provides information regarding each version of the PRC-005 standard.

Table 1: PRC-005 Effective Date Information		
Standard	Effective Date ¹	Comments
PRC-005-2	April 1, 2015	
PRC-005-2(i)	May 29, 2015	Proposed effective date with version 2, which was <u>will be</u> immediately following FERC A <u>approval</u> .
PRC-005-2(ii)	Filed and Pending Regulatory Approval	Proposed to be deferred; <u>will be replaced with</u> until version 6 <u>effective date</u> . ²
PRC-005-3	April 1, 2016	Proposed to be deferred; <u>will be replaced with</u> until version 6 <u>effective date</u> .
PRC-005-3(i)	April 1, 2016	Proposed to be deferred; <u>will be replaced with</u> until version 6 <u>effective date</u> .
PRC-005-3(ii)	Filed and Pending Regulatory Approval	Proposed to be deferred; <u>will be replaced with</u> until version 6 <u>effective date</u> .
PRC-005-4	Filed and Pending Regulatory Approval <u>January 1, 2016</u>	Proposed to be deferred; <u>will be replaced with</u> until version 6 <u>effective date</u> .
PRC-005-5	Pending Regulatory Filing	Proposed to be deferred; <u>will be replaced with</u> until version 6 <u>effective date</u> .
PRC-005-6	Pending Regulatory Filing	TBD

¹ The effective date listed is the start date of when the standard becomes effective. This does not include the phased in approach.

² The effective date is dependent on when FERC approves PRC-005-6, which could be from three (3) months to one (1) year after submittal of the petition for approval.

Standards Authorization Request Form

When completed, email this form to:
Howard.Gugel@nerc.net

For questions about this form or for assistance in
completing the form, call Howard Gugel at 404-
446-9693.

NERC welcomes suggestions for improving the
reliability of the Bulk-Power System through
improved Reliability Standards. Please use this form
to submit your proposal for a new NERC Reliability
Standard or a revision to an existing standard.

Request to propose a new or a revision to a Reliability Standard

Proposed Standard:	PRC-005-6		
Date Submitted:	May 21, 2015		
SAR Requester Information			
Name:	Charles Rogers		
Organization:	Protection System Maintenance Standard Drafting Team		
Telephone:	517-788-0027	E-mail:	Charles.Rogers@cmsenergy.com
SAR Type (Check as many as applicable)			
<input type="checkbox"/>	New Standard	<input type="checkbox"/>	Withdrawal of existing Standard
<input checked="" type="checkbox"/>	Revision to existing Standard	<input type="checkbox"/>	Urgent Action

Standards Authorization Request Form

SAR Information
Industry Need (What is the industry problem this request is trying to solve?):
<p>In Order No. 803, the Federal Energy Regulatory Commission (FERC or the Commission) approved Reliability Standard PRC-005-3 and, in Paragraph 31, directed that:</p> <p>"...pursuant to section 215(d)(5) of the FPA, NERC develop modifications to PRC-005-3 to include supervisory devices associated with auto-reclosing relay schemes to which the Reliability Standard applies. Further, we clarify that NERC’s proposal regarding the scope of supervisory devices is an acceptable approach to satisfy the Commission directive. Specifically, NERC proposed in its [FERC notice of proposed rulemaking (NOPR)] comments, and we find acceptable, that the scope of the supervisory devices to be encompassed in the Reliability Standard are those providing voltage supervision, supervisory inputs associated with selective auto-reclosing, and sync-check relays that are part of a reclosing scheme covered by PRC-005-3."</p>

SAR Information
Purpose or Goal (How does this request propose to address the problem described above?):
<p>The Standard Drafting Team (SDT) shall consider modifications, as needed, to address the FERC directive contained in Order 803 resulting from the Commission’s consideration of PRC-005-3.</p> <p>The Supplementary Reference Document (provided as a technical reference for PRC-005-3) should also be modified to provide the rationale for the maintenance activities and intervals within the revised standard, as well as to provide application guidance to industry.</p>
Identify the Objectives of the proposed standard’s requirements (What specific reliability deliverables are required to achieve the goal?):
<p>Provide clear, unambiguous requirements, standard specific definitions, and advisory guidance to address the directives in FERC Order 803.</p>
Brief Description (Provide a paragraph that describes the scope of this standard action.)
<p>The SDT shall modify NERC Standard PRC-005-3 to explicitly address the directive in Order 803. The SDT shall also consider changes to the standard and supporting documents that provide consistency and alignment with other Reliability Standards.</p>

SAR Information

Detailed Description (Provide a description of the proposed project with sufficient details for the standard drafting team to execute the SAR. Also provide a justification for the development or revision of the standard, including an assessment of the reliability and market interface impacts of implementing or not implementing the standard action.)

The SDT's execution of this SAR requires the SDT to address the directive in FERC Order 803. The SDT will develop requirement(s) to include supervisory devices associated with automatic reclosing relay schemes to which the Reliability Standard applies. The SDT may elect to propose revisions to the standard regarding the scope of supervisory devices as an acceptable approach to satisfy the Commission directive, as proposed in the NOPR comments submitted by NERC. Specifically, NERC proposed that the scope of the supervisory devices to be encompassed in the Reliability Standard are those providing voltage supervision, supervisory inputs associated with selective automatic reclosing, and synchronism check relays that are part of a reclosing scheme covered by PRC-005-3.

The SDT shall also:

1. Revise the Implementation Plans for PRC-005-2ii, PRC-005-3, PRC-005-3i, PRC-005-3ii, PRC-005-4 and PRC-005-5 as needed to facilitate consistent and systematic implementation.
2. Modify the informative Supplementary Reference Document (provided as a technical reference for PRC-005-3) as necessary to provide application guidance to industry.

Reliability Functions

The Standard will Apply to the Following Functions (Check each one that applies.)

<input type="checkbox"/> Regional Reliability Organization	Conducts the regional activities related to planning and operations, and coordinates activities of Responsible Entities to secure the reliability of the Bulk Electric System within the region and adjacent regions.
<input type="checkbox"/> Reliability Coordinator	Responsible for the real-time operating reliability of its Reliability Coordinator Area in coordination with its neighboring Reliability Coordinator's wide area view.

Standards Authorization Request Form

Reliability Functions	
<input type="checkbox"/> Balancing Authority	Integrates resource plans ahead of time, and maintains load-interchange-resource balance within a Balancing Authority Area and supports Interconnection frequency in real time.
<input type="checkbox"/> Interchange Authority	Ensures communication of interchange transactions for reliability evaluation purposes and coordinates implementation of valid and balanced interchange schedules between Balancing Authority Areas.
<input type="checkbox"/> Planning Coordinator	Assesses the longer-term reliability of its Planning Coordinator Area.
<input type="checkbox"/> Resource Planner	Develops a >one year plan for the resource adequacy of its specific loads within a Planning Coordinator area.
<input type="checkbox"/> Transmission Planner	Develops a >one year plan for the reliability of the interconnected Bulk Electric System within its portion of the Planning Coordinator area.
<input type="checkbox"/> Transmission Service Provider	Administers the transmission tariff and provides transmission services under applicable transmission service agreements (e.g., the pro forma tariff).
<input checked="" type="checkbox"/> Transmission Owner	Owns and maintains transmission facilities.
<input type="checkbox"/> Transmission Operator	Ensures the real-time operating reliability of the transmission assets within a Transmission Operator Area.
<input checked="" type="checkbox"/> Distribution Provider	Delivers electrical energy to the End-use customer.
<input checked="" type="checkbox"/> Generator Owner	Owns and maintains generation facilities.
<input type="checkbox"/> Generator Operator	Operates generation unit(s) to provide real and reactive power.
The Standard will Apply to the Following Functions (Check each one that applies.)	
<input type="checkbox"/> Purchasing-Selling Entity	Purchases or sells energy, capacity, and necessary reliability-related services as required.
<input type="checkbox"/> Market Operator	Interface point for reliability functions with commercial functions.
<input type="checkbox"/> Load-Serving Entity	Secures energy and transmission service (and reliability-related services) to serve the End-use Customer.

Standards Authorization Request Form

Reliability and Market Interface Principles	
Applicable Reliability Principles (Check all that apply).	
<input checked="" type="checkbox"/>	1. Interconnected bulk power systems shall be planned and operated in a coordinated manner to perform reliably under normal and abnormal conditions as defined in the NERC Standards.
<input type="checkbox"/>	2. The frequency and voltage of interconnected bulk power systems shall be controlled within defined limits through the balancing of real and reactive power supply and demand.
<input type="checkbox"/>	3. Information necessary for the planning and operation of interconnected bulk power systems shall be made available to those entities responsible for planning and operating the systems reliably.
<input type="checkbox"/>	4. Plans for emergency operation and system restoration of interconnected bulk power systems shall be developed, coordinated, maintained and implemented.
<input checked="" type="checkbox"/>	5. Facilities for communication, monitoring and control shall be provided, used and maintained for the reliability of interconnected bulk power systems.
<input type="checkbox"/>	6. Personnel responsible for planning and operating interconnected bulk power systems shall be trained, qualified, and have the responsibility and authority to implement actions.
<input type="checkbox"/>	7. The security of the interconnected bulk power systems shall be assessed, monitored and maintained on a wide area basis.
<input type="checkbox"/>	8. Bulk power systems shall be protected from malicious physical or cyber attacks.
Does the proposed Standard comply with all of the following Market Interface Principles?	
1. A reliability standard shall not give any market participant an unfair competitive advantage.	Enter (yes/no) Yes
2. A reliability standard shall neither mandate nor prohibit any specific market structure.	Yes
Does the proposed Standard comply with all of the following Market Interface Principles?	
3. A reliability standard shall not preclude market solutions to achieving compliance with that standard.	Enter (yes/no) Yes
4. A reliability standard shall not require the public disclosure of commercially sensitive information. All market participants shall have equal opportunity to access commercially non-sensitive information that is required for compliance with reliability standards.	Yes

Standards Authorization Request Form

Related Standards	
Standard No.	Explanation

Related SARs	
SAR ID	Explanation

Standards Authorization Request Form

Regional Variances	
Region	Explanation
ERCOT	
FRCC	
MRO	
NPCC	
RFC	
SERC	
SPP	
WECC	

Standards Authorization Request Form

When completed, email this form to:

Howard.Gugel@nerc.net ~~Valerie.Agnew@nerc.net~~

For questions about this form or for assistance in completing the form, call ~~Howard Gugel~~ [Valerie Agnew](mailto:Valerie.Agnew@nerc.net) at 404-446-~~2566~~[2566](tel:404-446-2566)~~9693~~.

NERC welcomes suggestions for improving the reliability of the Bulk-Power System through improved Reliability Standards. Please use this form to submit your proposal for a new NERC Reliability Standard or a revision to an existing standard.

Request to propose a new or a revision to a Reliability Standard

Proposed Standard:	PRC-005-6		
Date Submitted:	May 21, 2015		
SAR Requester Information			
Name:	Charles Rogers		
Organization:	Protection System Maintenance Standard Drafting Team		
Telephone:	517-788-0027	E-mail:	Charles.Rogers@cmsenergy.com
SAR Type (Check as many as applicable)			
<input type="checkbox"/>	New Standard	<input type="checkbox"/>	Withdrawal of existing Standard
<input checked="" type="checkbox"/>	Revision to existing Standard	<input type="checkbox"/>	Urgent Action

SAR Information
Industry Need (What is the industry problem this request is trying to solve?):
<p>In Order No. 803, the Federal Energy Regulatory Commission (FERC or the Commission) approved Reliability Standard PRC-005-3 and, in Paragraph 31, directed that:</p> <p>"...pursuant to section 215(d)(5) of the FPA, NERC develop modifications to PRC-005-3 to include supervisory devices associated with auto-reclosing relay schemes to which the Reliability Standard applies. Further, we clarify that NERC's proposal regarding the scope of supervisory devices is an acceptable approach to satisfy the Commission directive. Specifically, NERC proposed in its [FERC notice of proposed rulemaking (NOPR)] comments, and we find acceptable, that the scope of the supervisory devices to be encompassed in the Reliability Standard are those providing voltage supervision, supervisory inputs associated with selective auto-reclosing, and sync-check relays that are part of a reclosing scheme covered by PRC-005-3."</p>

SAR Information
Purpose or Goal (How does this request propose to address the problem described above?):
<p>The Standard Drafting Team (SDT) shall consider modifications, as needed, to address the FERC directive contained in Order 803 resulting from the Commission's consideration of PRC-005-3.</p> <p>The Supplementary Reference Document (provided as a technical reference for PRC-005-3) should also be modified to provide the rationale for the maintenance activities and intervals within the revised standard, as well as to provide application guidance to industry.</p>
Identify the Objectives of the proposed standard's requirements (What specific reliability deliverables are required to achieve the goal?):
<p>Provide clear, unambiguous requirements, standard specific definitions-standard(s), and advisory guidance to address the directives in FERC Order 803.</p>
Brief Description (Provide a paragraph that describes the scope of this standard action.)
<p>The Standard Drafting Team (SDT) shall modify NERC Standard PRC-005-3 to explicitly address the directive in Order 803. The SDT shall also consider changes to the standard and supporting documents that provide consistency and alignment with other Reliability Standards.</p>

SAR Information

Detailed Description (Provide a description of the proposed project with sufficient details for the standard drafting team to execute the SAR. Also provide a justification for the development or revision of the standard, including an assessment of the reliability and market interface impacts of implementing or not implementing the standard action.)

The SDT's execution of this SAR requires the SDT to address the directive in FERC Order 803. The SDT will develop requirement(s) to include supervisory devices associated with automatic reclosing relay schemes to which the Reliability Standard applies. The SDT may elect to propose revisions to the standard regarding the scope of supervisory devices as an acceptable approach to satisfy the Commission directive, as proposed in the NOPR comments submitted by NERC. Specifically, NERC proposed that the scope of the supervisory devices to be encompassed in the Reliability Standard are those providing voltage supervision, supervisory inputs associated with selective automatic reclosing, and synchronism check relays that are part of a reclosing scheme covered by PRC-005-3.

The SDT shall also:

1. Revise the Implementation Plans for ~~PRC-002i~~, PRC-005-2ii, PRC-005-3, PRC-005-3i, PRC-005-3ii, PRC-005-4 and PRC-005-5 as needed to facilitate consistent and systematic implementation.
2. Modify the informative Supplementary Reference Document (provided as a technical reference for PRC-005-3) as necessary to provide application guidance to industry.

Reliability Functions

The Standard will Apply to the Following Functions (Check each one that applies.)

<input type="checkbox"/>	Regional Reliability Organization	Conducts the regional activities related to planning and operations, and coordinates activities of Responsible Entities to secure the reliability of the Bulk Electric System within the region and adjacent regions.
<input type="checkbox"/>	Reliability Coordinator	Responsible for the real-time operating reliability of its Reliability Coordinator Area in coordination with its neighboring Reliability Coordinator's wide area view.

Reliability Functions		
<input type="checkbox"/> <input checked="" type="checkbox"/>	Balancing Authority	Integrates resource plans ahead of time, and maintains load-interchange-resource balance within a Balancing Authority Area and supports Interconnection frequency in real time.
<input type="checkbox"/>	Interchange Authority	Ensures communication of interchange transactions for reliability evaluation purposes and coordinates implementation of valid and balanced interchange schedules between Balancing Authority Areas.
<input type="checkbox"/>	Planning Coordinator	Assesses the longer-term reliability of its Planning Coordinator Area.
<input type="checkbox"/>	Resource Planner	Develops a >one year plan for the resource adequacy of its specific loads within a Planning Coordinator area.
<input type="checkbox"/>	Transmission Planner	Develops a >one year plan for the reliability of the interconnected Bulk Electric System within its portion of the Planning Coordinator area.
<input type="checkbox"/>	Transmission Service Provider	Administers the transmission tariff and provides transmission services under applicable transmission service agreements (e.g., the pro forma tariff).
<input checked="" type="checkbox"/>	Transmission Owner	Owns and maintains transmission facilities.
<input type="checkbox"/>	Transmission Operator	Ensures the real-time operating reliability of the transmission assets within a Transmission Operator Area.
<input checked="" type="checkbox"/>	Distribution Provider	Delivers electrical energy to the End-use customer.
<input checked="" type="checkbox"/>	Generator Owner	Owns and maintains generation facilities.
<input type="checkbox"/>	Generator Operator	Operates generation unit(s) to provide real and reactive power.
The Standard will Apply to the Following Functions (Check each one that applies.)		
<input type="checkbox"/>	Purchasing-Selling Entity	Purchases or sells energy, capacity, and necessary reliability-related services as required.
<input type="checkbox"/>	Market Operator	Interface point for reliability functions with commercial functions.
<input type="checkbox"/>	Load-Serving Entity	Secures energy and transmission service (and reliability-related services) to serve the End-use Customer.

Reliability and Market Interface Principles

Applicable Reliability Principles (Check all that apply).

<input checked="" type="checkbox"/>	1. Interconnected bulk power systems shall be planned and operated in a coordinated manner to perform reliably under normal and abnormal conditions as defined in the NERC Standards.
<input type="checkbox"/>	2. The frequency and voltage of interconnected bulk power systems shall be controlled within defined limits through the balancing of real and reactive power supply and demand.
<input type="checkbox"/>	3. Information necessary for the planning and operation of interconnected bulk power systems shall be made available to those entities responsible for planning and operating the systems reliably.
<input type="checkbox"/>	4. Plans for emergency operation and system restoration of interconnected bulk power systems shall be developed, coordinated, maintained and implemented.
<input checked="" type="checkbox"/>	5. Facilities for communication, monitoring and control shall be provided, used and maintained for the reliability of interconnected bulk power systems.
<input type="checkbox"/>	6. Personnel responsible for planning and operating interconnected bulk power systems shall be trained, qualified, and have the responsibility and authority to implement actions.
<input type="checkbox"/>	7. The security of the interconnected bulk power systems shall be assessed, monitored and maintained on a wide area basis.
<input type="checkbox"/>	8. Bulk power systems shall be protected from malicious physical or cyber attacks.

Does the proposed Standard comply with all of the following Market Interface Principles?	Enter (yes/no)
1. A reliability standard shall not give any market participant an unfair competitive advantage.	Yes
2. A reliability standard shall neither mandate nor prohibit any specific market structure.	Yes
Does the proposed Standard comply with all of the following Market Interface Principles?	Enter (yes/no)
3. A reliability standard shall not preclude market solutions to achieving compliance with that standard.	Yes
4. A reliability standard shall not require the public disclosure of commercially sensitive information. All market participants shall have equal opportunity to access commercially non-sensitive information that is required for compliance with reliability standards.	Yes

Formatted: Font: (Default) +Headings (Tahoma), 9 pt, Bold, Font color: Accent 2

Related Standards	
Standard No.	Explanation

Related SARs	
SAR ID	Explanation

Formatted: Font: (Default) +Headings (Tahoma), 9 pt, Bold, Font color: Accent 2

Regional Variances	
Region	Explanation
ERCOT	
FRCC	
MRO	
NPCC	
RFC	
SERC	
SPP	
WECC	

NERC

NORTH AMERICAN ELECTRIC
RELIABILITY CORPORATION

Supplementary Reference and FAQ

PRC-005-6 Protection System, Automatic
Reclosing, and Sudden Pressure Relaying
Maintenance and Testing

October 2015

RELIABILITY | ACCOUNTABILITY



3353 Peachtree Road NE
Suite 600, North Tower
Atlanta, GA 30326
404-446-2560 | www.nerc.com

Table of Contents

Table of Contents.....	ii
1. Introduction and Summary.....	1
2. Need for Verifying Protection System Performance	3
2.1 Existing NERC Standards for Protection System Maintenance and Testing	3
2.2 Protection System Definition	4
2.3 Applicability of New Protection System Maintenance Standards	4
2.3.1 Frequently Asked Questions:	5
2.4.1 Frequently Asked Questions:	7
3. Protection System and Automatic Reclosing Product Generations	14
4. Definitions.....	16
4.1 Frequently Asked Questions:	17
5. Time-Based Maintenance (TBM) Programs.....	19
5.1 Maintenance Practices.....	19
5.1.1 Frequently Asked Questions:	21
5.2 Extending Time-Based Maintenance	22
5.2.1 Frequently Asked Questions:	23
6. Condition-Based Maintenance (CBM) Programs.....	24
6.1 Frequently Asked Questions:	24
7. Time-Based Versus Condition-Based Maintenance.....	26
7.1 Frequently Asked Questions:	26
8. Maximum Allowable Verification Intervals.....	32
8.1 Maintenance Tests.....	32
8.1.1 Table of Maximum Allowable Verification Intervals.....	32

8.1.2 Additional Notes for Tables 1-1 through 1-5, Table 3, and Table 4.....	34
8.1.3 Frequently Asked Questions:	35
8.2 Retention of Records.....	40
8.2.1 Frequently Asked Questions:	41
8.3 Basis for Table 1 Intervals	43
8.4 Basis for Extended Maintenance Intervals for Microprocessor Relays	44
9. Performance-Based Maintenance Process.....	47
9.1 Minimum Sample Size.....	48
9.2 Frequently Asked Questions:	51
10. Overlapping the Verification of Sections of the Protection System.....	62
10.1 Frequently Asked Questions:	62
11. Monitoring by Analysis of Fault Records	63
11.1 Frequently Asked Questions:	64
12. Importance of Relay Settings in Maintenance Programs	65
12.1 Frequently Asked Questions:	65
13. Self-Monitoring Capabilities and Limitations.....	68
13.1 Frequently Asked Questions:	69
14. Notification of Protection System or Automatic Reclosing Failures.....	70
15. Maintenance Activities	71
15.1 Protective Relays (Table 1-1)	71
15.1.1 Frequently Asked Questions:	71
15.2 Voltage & Current Sensing Devices (Table 1-3)	71
15.2.1 Frequently Asked Questions:	73
15.3 Control circuitry associated with protective functions (Table 1-5)	74
15.3.1 Frequently Asked Questions:	75

15.4 Batteries and DC Supplies (Table 1-4).....	77
15.4.1 Frequently Asked Questions:	78
15.5 Associated communications equipment (Table 1-2)	92
15.5.1 Frequently Asked Questions:	93
15.6 Alarms (Table 2)	96
15.6.1 Frequently Asked Questions:	97
15.7 Distributed UFLS and Distributed UVLS Systems (Table 3).....	97
15.7.1 Frequently Asked Questions:	98
15.8 Automatic Reclosing (Table 4)	98
15.8.1 Frequently-asked Questions	98
15.9 Examples of Evidence of Compliance	101
15.9.1 Frequently Asked Questions:	103
References	104
Figures.....	106
Figure 1: Typical Transmission System.....	106
Figure 2: Typical Generation System	107
Figure 1 & 2 Legend – Components of Protection Systems	108
Appendix A.....	109
Appendix B	112
Protection System Maintenance Standard Drafting Team.....	112

1. Introduction and Summary

Note: This supplementary reference for PRC-005-6 is neither mandatory nor enforceable.

NERC currently has four Reliability Standards that are mandatory and enforceable within the jurisdiction of the ERO and address various aspects of maintenance and testing of Protection and Control Systems.

These standards are:

PRC-005-1.1b — Transmission and Generation Protection System Maintenance and Testing

PRC-008-0 — Underfrequency Load Shedding Equipment Maintenance Programs

PRC-011-0 — UVLS System Maintenance and Testing

PRC-017-0 — Special Protection System Maintenance and Testing

While these standards require that applicable entities have a maintenance program for Protection Systems, and that these entities must be able to demonstrate they are carrying out such a program, there are no specifics regarding the technical requirements for Protection System maintenance programs. Furthermore, FERC Order 693¹ directed additional modifications to the respective Protection System maintenance programs. PRC-005-3 will replace PRC-005-2 which combined and replaced PRC-005, PRC-008, PRC-011 and PRC-017. PRC-005-3 adds Automatic Reclosing to PRC-005-2. PRC-005-2 addressed these directed modifications and replaces PRC-005, PRC-008, PRC-011 and PRC-017.

FERC Order 758² further directed that maintenance of reclosing relays and sudden pressure relays that affect the reliable operation of the Bulk Power System be addressed. PRC-005-3 addresses this directive regarding reclosing relays, and, when approved, will supersede PRC-005-2. PRC-005-4 addresses this directive regarding sudden pressure relays and, when approved, will supersede PRC-005-3.

This document augments the Supplementary Reference and FAQ previously developed for PRC-005-4 by including discussions relevant to the following standard revisions:

- PRC-005-3 – add Automatic Reclosing in accordance with directives in FERC Order 758 as supported by the technical reports of the System Protection Control Subcommittee and the System Analysis and Modeling Subcommittee

¹ *Mandatory Reliability Standards for the Bulk-Power System*, Order No. 693, 118 FERC ¶ 61,218, FERC Stats. & Regs. ¶ 31,242 (“Order No. 693”), *order on reh’g*, *Mandatory Reliability Standards for the Bulk-Power System*, 120 FERC ¶ 61,053 (Order No. 693-A) (2007).

² *Interpretation of Protection System Reliability Standard*, Order No. 758, 138 FERC ¶ 61,094 (2012) (“Order No. 758”).

-
- PRC-005-4 – add Sudden Pressure Relaying in accordance with directives in FERC Order 758 as supported by the technical report of the System Protection Control Subcommittee
 - PRC-005-5 – update Applicability requirements for dispersed generation resources to align with revisions to the definition of the Bulk Electric System
 - PRC-005-6 – add supervisory relays to Automatic Reclosing in accordance with directives in FERC Order 803³.

³ *Protection System Maintenance Reliability Standard*, Order No. 803, 150 FERC ¶ 61,039 (2015) (“Order No. 803”).

2. Need for Verifying Protection System Performance

Protective relays have been described as silent sentinels, and do not generally demonstrate their performance until a Fault or other power system problem requires that they operate to protect power system Elements, or even the entire Bulk Electric System (BES). Lacking Faults, switching operations or system problems, the Protection Systems may not operate, beyond static operation, for extended periods. A Misoperation— defined as --a false operation of a Protection System or a failure of the Protection System to operate, as designed, when needed--can result in equipment damage, personnel hazards, and wide-area Disturbances or unnecessary customer outages. Maintenance or testing programs are used to determine the performance and availability of Protection Systems.

Typically, utilities have tested Protection Systems at fixed time intervals, unless they had some incidental evidence that a particular Protection System was not behaving as expected. Testing practices vary widely across the industry. Testing has included system functionality, calibration of measuring devices, and correctness of settings. Typically, a Protection System must be visited at its installation site and, in many cases, removed from service for this testing.

Fundamentally, a Reliability Standard for Protection System Maintenance and Testing requires the performance of the maintenance activities that are necessary to detect and correct plausible age and service related degradation of the Protection System components, such that a properly built and commissioned Protection System will continue to function as designed over its service life.

Similarly station batteries, which are an important part of the station dc supply, are not called upon to provide instantaneous dc power to the Protection System until power is required by the Protection System to operate circuit breakers or interrupting devices to clear Faults or to isolate equipment.

2.1 Existing NERC Standards for Protection System Maintenance and Testing

For critical BES protection functions, NERC standards have required that each utility or asset owner define a testing program. The starting point is the Board approved Standard PRC-005-5, briefly restated as follows:

Purpose: To document and implement programs for the maintenance of all Protection Systems affecting the reliability of the Bulk Electric System (BES) so that these Protection Systems are kept in working order.

PRC-005-6 is not specific on where the boundaries of the Protection Systems lie. However, the definition of Protection System in the [Glossary of Terms](#) Used in NERC Reliability Standards (Glossary) indicates what must be included as a minimum.

At the beginning of the project to develop PRC-005-2, the definition of Protection System was:

Protective relays, associated communications Systems, voltage and current sensing devices, station batteries and dc control circuitry.

Applicability: Owners of generation and transmission Protection Systems.

Requirements: The owner shall have a documented maintenance program with test intervals. The owner must keep records showing that the maintenance was performed at the specified intervals.

2.2 Protection System Definition

The most recently approved definition of Protection Systems is:

- Protective relays which respond to electrical quantities,
- Communications systems necessary for correct operation of protective functions,
- Voltage and current sensing devices providing inputs to protective relays,
- Station dc supply associated with protective functions (including station batteries, battery chargers, and non-battery-based dc supply), and
- Control circuitry associated with protective functions through the trip coil(s) of the circuit breakers or other interrupting devices.

2.3 Applicability of New Protection System Maintenance Standards

The BES purpose is to transfer bulk power. The applicability language has been changed from the original PRC-005:

“...affecting the reliability of the Bulk Electric System (BES)...”

To the present language:

“...that are installed for the purpose of detecting Faults on BES Elements (lines, buses, transformers, etc.).”

The drafting team intends that this standard will be consistent with any future definition of the Bulk Electric System. There should be no ambiguity; if the Element is a BES Element, then the Protection System protecting that Element should then be included within this standard. If there is regional variation to the definition, then there will be a corresponding regional variation to the Protection Systems that fall under this standard.

There is no way for the Standard Drafting Team to know whether a specific 230KV line, 115KV line (even 69KV line), for example, should be included or excluded. Therefore, the team expressed the clear intent that the standard language should simply be applicable to Protection Systems for BES Elements.

The BES is a NERC defined term that, from time to time, may undergo revisions. Additionally, there may be regional variations that are allowed in the present and future definitions.⁴ Refer to the applicable Regional Reliability Organization for any applicable allowed variations.

While this standard may undergo revisions in the future, this standard will not attempt to keep up with revisions to the NERC definition of BES, but, rather, simply make BES Protection Systems applicable.

The Standard is applied to Generator Owners (GO) and Transmission Owners (TO) because GOs and TOs have BES equipment. The standard brings in Distribution Providers (DP) because,

⁴ See the NERC Glossary of Terms for the present, in-force definition.

depending on the station configuration of a particular substation, there may be Protection System equipment installed at a non-transmission voltage level (Distribution Provider equipment) that is wholly or partially installed to protect the BES. PRC-005-2 would apply to this equipment. An example is underfrequency load-shedding, which is frequently applied in distribution systems to meet PRC-007-0.

PRC-005-2 replaced the existing PRC-005, PRC-008, PRC-011 and PRC-017. Much of the original language of those standards was carried forward whenever it was possible to continue the intent and avoid a conflict with FERC Order 693. For example, the original PRC-008 was constructed quite differently than the original PRC-005. The drafting team agrees with the intent of this and notes that distributed tripping schemes would have to exhibit multiple failures to trip before they would prove to be significant, as opposed to a single failure to trip of, for example, a transmission Protection System Bus Differential lock-out relay. While a substantial number of failures of these distribution breakers could be significant, the team concluded likely that distribution breakers are operated often only for Fault clearing duty; and, therefore, the distribution circuit breakers are operated at least as frequently as stipulated in any requirement in this standard.

Additionally, since PRC-005-2 replaced PRC-011, it will be important to distinguish between under-voltage Protection Systems that protect individual Loads and Protection Systems that are Undervoltage Load Shedding (UVLS) schemes that protect the BES. Any UVLS scheme that had been applicable under PRC-011 is now applicable under PRC-005-2. An example of an under-voltage load-shedding scheme that is not applicable to this standard is one in which the tripping action was intended to prevent low distribution voltage to a specific Load from a Transmission system that was intact except for the line that was out of service, as opposed to preventing a Cascading outage or Transmission system collapse.

It had been correctly noted that the devices needed for PRC-011 are the very same types of devices needed in PRC-005.

Thus, a standard written for Protection Systems of the BES can easily make the needed requirements for Protection Systems, and replace some other standards at the same time.

2.3.1 Frequently Asked Questions:

What exactly is the BES, or Bulk Electric System?

BES is the abbreviation for the defined term Bulk Electric System. BES is a term in the Glossary of Terms used in Reliability Standards, and is not being modified within this draft standard.

Why is Distribution Provider included within the Applicable Entities and as a responsible entity within several of the requirements? Wouldn't anyone having relevant Facilities be a Transmission Owner?

Depending on the station configuration of a particular substation, there may be Protection System equipment installed at a non-transmission voltage level (Distribution Provider equipment) that is wholly or partially installed to protect the BES. PRC-005-2 applies to this equipment. An example is underfrequency load-shedding, which is frequently applied well down into the distribution system to meet the requirements of PRC-007-0.

We have an under voltage load-shedding (UVLS) system in place that prevents one of our distribution substations from supplying extremely low voltage in the case of a specific transmission line outage. The transmission line is part of the BES. Does this mean that our UVLS system falls within this standard?

The situation, as stated, indicates that the tripping action was intended to prevent low distribution voltage to a specific Load from a Transmission System that was intact, except for the line that was out of service, as opposed to preventing Cascading outage or Transmission System Collapse. This standard is not applicable to this UVLS.

We have a UFLS or UVLS scheme that sheds the necessary Load through distribution-side circuit breakers and circuit reclosers. Do the trip-test requirements for circuit breakers apply to our situation?

No--Distributed tripping schemes would have to exhibit multiple failures to trip before they would prove to be significant, as opposed to a single failure to trip of, for example, a transmission Protection System bus differential lock-out relay. While many failures of these distribution breakers could add up to be significant, it is also believed that distribution breakers are operated often on just Fault clearing duty; and, therefore, the distribution circuit breakers are operated at least as frequently as any requirements that might have appeared in this standard.

We have a UFLS scheme that, in some locales, sheds the necessary Load through non-BES circuit breakers and, occasionally, even circuit switchers. Do the trip-test requirements for circuit breakers apply to our situation?

If your “non-BES circuit breaker” has been brought into this standard by the inclusion of UFLS requirements, and otherwise would not have been brought into this standard, then the answer is that there are no trip-test requirements. For these devices that are otherwise non-BES assets, these tripping schemes would have to exhibit multiple failures to trip before they would prove to be as significant as, for example, a single failure to trip of a transmission Protection System bus differential lock-out relay.

How does the “Facilities” section of “Applicability” track with the standards that will be retired once PRC-005-2 becomes effective?

In establishing PRC-005-2, the drafting team combined legacy standards PRC-005-1b, PRC-008-0, PRC-011-0, and PRC-017-0. The merger of the subject matter of these standards is reflected in Applicability 4.2.

The intent of the drafting team is that the legacy standards be reflected in PRC-005-2 as follows:

- Applicability of PRC-005-1.1b for Protection Systems relating to non-generator elements of the BES is addressed in 4.2.1.
- Applicability of PRC-008-0 for underfrequency load shedding systems is addressed in 4.2.2.
- Applicability of PRC-011-0 for undervoltage load shedding relays is addressed in 4.2.3.
- Applicability of PRC-017-0 for Remedial Action Schemes is addressed in 4.2.4.
- Applicability of PRC-005-1.1b for Protection Systems for BES generators is addressed in 4.2.5 and 4.2.6.

2.4 Applicable Relays

The Glossary definition has a Protection System including relays, dc supply, current and voltage sensing devices, dc control circuitry and associated communications circuits. The relays to which this standard applies are those protective relays that respond to electrical quantities and provide a trip output to trip coils, dc control circuitry or associated communications equipment. This definition extends to IEEE Device No. 86 (lockout relay) and IEEE Device No. 94 (tripping or trip-free relay), as these devices are tripping relays that respond to the trip signal of the protective relay that processed the signals from the current and voltage-sensing devices.

Relays that respond to non-electrical inputs or impulses (such as, but not limited to, vibration, seismic, thermal or gas accumulation) are not included.

Automatic Reclosing is addressed in PRC-005-3 by explicitly addressing them outside the definition of Protection System. The specific locations for applicable Automatic Reclosing are addressed in Applicability Section 4.2.7.

Sudden Pressure Relaying is addressed in PRC-005-4 by explicitly addressing them outside the definition of Protection System. The specific locations for applicable Sudden Pressure Relaying are addressed in Applicability Section 4.2.1, 4.2.5.2, 4.2.5.3, and 4.2.6.

2.4.1 Frequently Asked Questions:

Are power circuit reclosers, reclosing relays, closing circuits and auto-restoration schemes covered in this Standard?

Yes. Automatic Reclosing includes reclosing relays and the associated dc control circuitry. Section 4.2.7 of the Applicability specifically limits the applicable reclosing relays to:

4.2.7 Automatic Reclosing

4.2.7.1 Automatic Reclosing applied on the terminals of Elements connected to the BES bus located at generating plant substations where the total installed gross generating plant capacity is greater than the gross capacity of the largest BES generating unit within the Balancing Authority Area or, if a member of a Reserve Sharing Group, the largest generating unit within the Reserve Sharing Group.

4.2.7.2 Automatic Reclosing applied on the terminals of all BES Elements at substations one bus away from generating plants specified in Section 4.2.7.1 when the substation is less than 10 circuit-miles from the generating plant substation.

4.2.7.3 Automatic Reclosing applied as an integral part of an RAS specified in Section 4.2.4.

Further, Footnote 1 to Applicability Section 4.2.7 establishes that Automatic Reclosing addressed in 4.2.7.1 and 4.2.7.2 may be excluded if the equipment owner can demonstrate that a close-in three-phase fault present for twice the normal clearing time (capturing a minimum trip-close-trip time delay) does not result in a total loss of gross generation in the Interconnection exceeding the gross capacity of the largest relevant BES generating unit where the Automatic Reclosing is applied.

Additionally, Footnote 2 to Applicability Section 4.2.7.1 advises that the entity's PSMP needs to remain current regarding the applicability of Automatic Reclosing Components relative to the largest generating unit within the Balancing Authority Area or Reserve Sharing Group.

The Applicability as detailed above was recommended by the NERC System Analysis and Modeling Subcommittee (SAMS) after a lengthy review of the use of reclosing within the BES. SAMS concluded that automatic reclosing is largely implemented throughout the BES as an operating convenience, and that automatic reclosing mal-performance affects BES reliability only when the reclosing is part of a Remedial Action Schemes, or when premature autoreclosing has the potential to cause generating unit or plant instability. A technical report, "Considerations for Maintenance and Testing of Autoreclosing Schemes — November 2012", is referenced in PRC-005-3 and provides a more detailed discussion of these concerns.

Why did the standard drafting team not include IEEE device numbers to describe Automatic Reclosing Relays?

The drafting team elected not to include IEEE device numbers to describe Automatic Reclosing because Automatic Reclosing component type could be a stand-alone electromechanical relay; or could be the 79 function within a microprocessor based multi-function relay.

Was it the drafting team's intent that the definition of Automatic Reclosing incorporate all closings that happen automatically, or just Automatic Reclosing relays?

The drafting team believes that Automatic Reclosing definition, as supported by the second part of the IEEE Standard 100 definition stating "Automatic reclosing equipment - Automatic equipment that provides for reclosing a switching device as desired after it has opened automatically under abnormal conditions..." adequately addresses this concern. Automatic Reclosing does not include actions such as automatic closing of the circuit breakers associated with shunt or series capacitor banks or shunt reactors.

What is synchronizing or synchronism check relay (Sync-Check - 25)?

A synchronizing device that produces an output that supervises closure of a circuit breaker between two circuits whose voltages are within prescribed limits of magnitude and within the prescribed phase angle for the prescribed time. It may or may not include voltage or speed control. A sync-check relay permits the paralleling of two circuits that are within prescribed (usually wider) limits of voltage magnitude and phase angle for the prescribed time.

How do I interpret Applicability Section 4.2.7 to determine applicability in the following examples:

At my generating plant substation, I have a total of 800 MW connected to one voltage level and 200 MW connected to another voltage level. How do I determine my gross capacity? Where do I consider Automatic Reclosing to be applicable?

Scenario number 1:

The 800 MW of generation is connected to a BES voltage level bus, the 200 MW is connected to a non-BES voltage level bus, and there is no connection between the two buses locally or within 10 circuit miles from the generating plant substation. The largest single unit in the BA area is 750 MW.

In this case, the total installed gross generating capacity would be 800 MW. The two units are essentially independent plants.

The BES voltage level bus is considered to be the bus to which the 800 MW of generation is connected. Any BES Automatic Reclosing at this location, as well as other locations within 10 circuit miles, is considered to be applicable because 800 MW exceeds the largest single unit in the BA area.

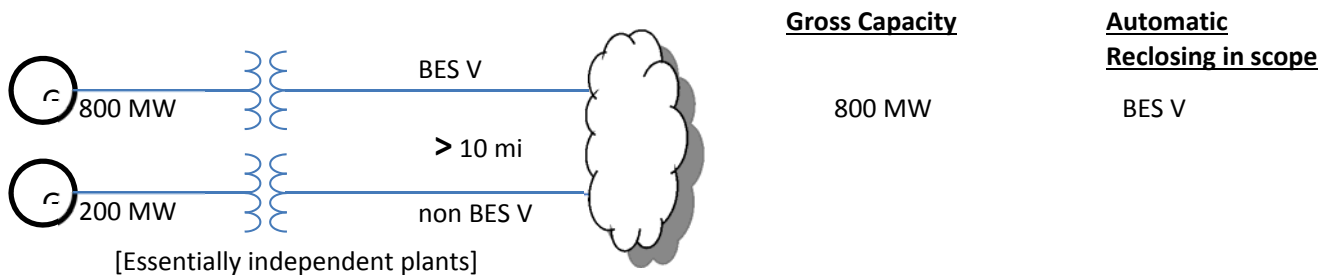

Scenario number 2:

The 800 MW of generation is connected to a BES voltage level bus, the 200 MW unit is connected to a non-BES voltage level bus, and there is a connection between the two buses locally or within 10 circuit miles from the generating plant substation. The largest single unit in the BA area is 750 MW.

In this case, reclosing into a fault on the BES system could impact the stability of the non-BES-connected generating units. Therefore, the total installed gross generating capacity would be 1000 MW.

The BES voltage level bus is considered to be the bus to which the 800 MW of generation is connected. Any BES Automatic Reclosing at this location, as well as other locations within 10 circuit miles, is considered to be applicable because total of 1000 MW exceeds the largest single unit in the BA area. However, the Automatic Reclosing on the non-BES voltage level bus is not applicable.

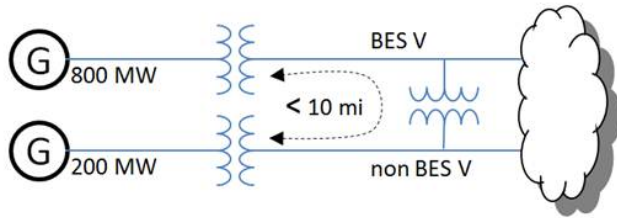

Gross Capacity

Automatic Reclosing in scope

1000 MW

BES V

Scenario number 3:

The 800 MW of generation is connected to a BES voltage level bus, the 200 MW unit is connected to a non-BES voltage level bus, and there is no connection between the two buses locally or within 10 circuit miles from the generating plant substation but the generating units connected at the BES voltage level do not operate independently of the units connected at the non BES voltage level (e.g., a combined cycle facility where 800 MW of combustion turbines are connected at a BES voltage level whose exhaust is used to power a 200 MW steam unit connected to a non BES voltage level. The largest single unit in the BA area is 750 MW.

In this case, the total installed gross generating capacity would be 1000 MW. Therefore, reclosing into a fault on the BES voltage level would result in a loss of the 800 MW combustion turbines and subsequently result in the loss of the 200 MW steam unit because of the loss of the heat source to its boiler.

The BES voltage level bus is considered to be the bus to which the 800 MW of generation is connected. Any BES Automatic Reclosing at this location, as well as other locations within 10 circuit miles, is considered to be applicable because total of 1000 MW exceeds the largest single unit in the BA area. However, the Automatic Reclosing on the non-BES voltage level bus is not applicable.

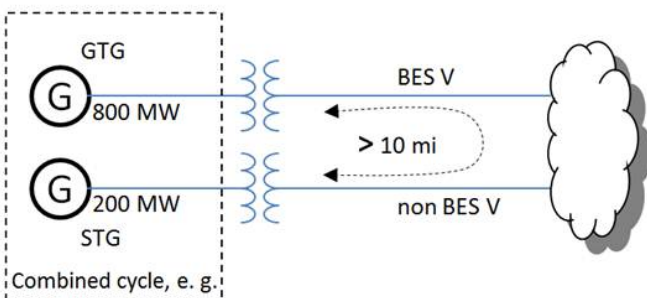

Gross Capacity

Automatic Reclosing in scope

1000 MW

BES V

Scenario 4

The 800 MW of generation is connected at 345 kV and the 200 MW is connected at 138 kV with an autotransformer at the generating plant substation connecting the two voltage levels. The largest single unit in the BA area is 900 MW.

In this case, the total installed gross generating capacity would be 1000 MW and section 4.2.7.1 would be applicable to both the 345 kV Automatic Reclosing Components and the 138 kV

Automatic Reclosing Components, since the total capacity of 1000 MW is larger than the largest single unit in the BA area.

However, if the 345 kV and the 138 kV systems can be shown to be uncoupled such that the 138 kV reclosing relays will not affect the stability of the 345 kV generating units then the 138 kV Automatic Reclosing Components need not be included per section 4.2.7.1.

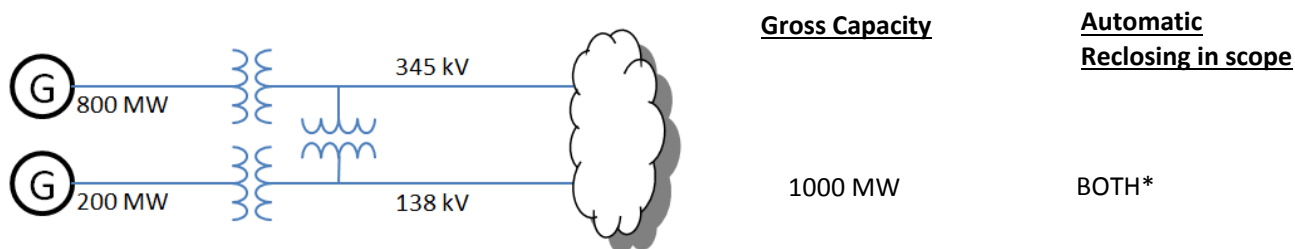

* The study detailed in Footnote 1 of the draft standard may eliminate the 138 kV Automatic Reclosing Components and/or the 345 kV Automatic Reclosing Components

Why does 4.2.7.2 specify “10 circuit miles”?

As noted in “Considerations for Maintenance and Testing of Autoreclosing Schemes — November 2012,” transmission line impedance on the order of one mile away typically provides adequate impedance to prevent generating unit instability and a 10 mile threshold provides sufficient margin.

Should I use MVA or MW when determining the installed gross generating plant capacity?

Be consistent with the rating used by the Balancing Authority for the largest BES generating unit within their area.

What value should we use for generating plant capacity in 4.2.7.1?

Use the value reported to the Balance Authority for generating plant capacity for planning and modeling purposes. This can be nameplate or other values based on generating plant limitations such as boiler or turbine ratings.

What is considered to be “one bus away” from the generation?

The BES voltage level bus is considered to be the generating plant substation bus to which the generator step-up transformer is connected. “One bus away” is the next bus, connected by either a transmission line or transformer.

I use my protective relays only as sources of metered quantities and breaker status for SCADA and EMS through a substation distributed RTU or data concentrator to the control center. What are the maintenance requirements for the relays?

This standard addresses Protection Systems that are installed for the purpose of detecting Faults on BES Elements (e.g. lines, buses, transformers, etc.). Protective relays, providing only the functions mentioned in the question, are not included.

Are Reverse Power Relays installed on the low-voltage side of distribution banks considered to be components of “Protection Systems that are installed for the purpose of detecting Faults on BES Elements (i.e.lines, buses, transformers, etc.)?”

Reverse power relays are often installed to detect situations where the transmission source becomes de-energized and the distribution bank remains energized from a source on the low-voltage side of the transformer and the settings are calculated based on the charging current of the transformer from the low-voltage side. Although these relays may operate as a result of a fault on a BES element, they are not “installed for the purpose of detecting” these faults.

Why is the maintenance of Sudden Pressure Relaying being addressed in PRC-005-6?

Proper performance of Sudden Pressure Relaying supports the reliability of the BES because fault pressure relays can detect rapid changes in gas pressure, oil pressure, or oil flow that are indicative of faults within liquid-filled, wire-wound equipment such as turn-to-turn faults which may be undetected by Protection Systems. Additionally, Sudden Pressure Relaying can quickly detect faults and operate to limit damage to liquid-filled, wire-wound equipment.

What type of devices are classified as fault pressure relay?

There are three main types of fault pressure relays; rapid gas pressure rise, rapid oil pressure rise, and rapid oil flow devices.

Rapid gas pressure devices monitor the pressure in the space above the oil (or other liquid), and initiate tripping action for a rapid rise in gas pressure resulting from the rapid expansion of the liquid caused by a fault. The sensor is located in the gas space.

Rapid oil pressure devices monitor the pressure in the oil (or other liquid), and initiate tripping action for a rapid pressure rise caused by a fault. The sensor is located in the liquid.

Rapid oil flow devices, Buchholz) monitor the liquid flow between a transformer/reactor and its conservator. Normal liquid flow occurs continuously with ambient temperature changes and with internal heating from loading and does not operate the rapid oil flow device. However, when an internal arc occurs, a sudden expansion of liquid can be monitored as rapid liquid flow from the transformer into the conservator resulting in actuation of the rapid oil flow device.

Are sudden pressure relays that only initiate an alarm included in the scope of PRC-005-6?

No--the definition of Sudden Pressure Relaying specifies only those that trip an interrupting device(s) to isolate the equipment it is monitoring.

Are pressure relief devices (PRD) included in the scope of PRC-005-6?

No--PRDs are not included in the Sudden Pressure Relaying definition.

Is Sudden Pressure Relaying installed on distribution transformers included in PRC-005-6?

No--Applicability 4.2.1, 4.2.5, and 4.2.6 explicitly describes what Sudden Pressure Relaying is included within the standard.

Are non-electrical sensing devices (other than fault pressure relays) such as low oil level or high winding temperatures included in PRC-005-6?

No--based on the SPCS technical document, "Sudden Pressure Relays and Other Devices that Respond to Non-Electrical Quantities – December 2013," the only applicable non-electrical sensing devices are Sudden Pressure Relays.

The standard specifically mentions auxiliary and lock-out relays. What is an auxiliary tripping relay?

An auxiliary relay, IEEE Device No. 94, is described in IEEE Standard C37.2-2008 as: "A device that functions to trip a circuit breaker, contactor, or equipment; to permit immediate tripping by other devices; or to prevent immediate reclosing of a circuit interrupter if it should open automatically, even though its closing circuit is maintained closed."

What is a lock-out relay?

A lock-out relay, IEEE Device No. 86, is described in IEEE Standard C37.2 as: "A device that trips and maintains the associated equipment or devices inoperative until it is reset by an operator, either locally or remotely."

3. Protection System and Automatic Reclosing Product Generations

The likelihood of failure and the ability to observe the operational state of a critical Protection System and Automatic Reclosing both depend on the technological generation of the relays, as well as how long they have been in service. Unlike many other transmission asset groups, protection and control systems have seen dramatic technological changes spanning several generations. During the past 20 years, major functional advances are primarily due to the introduction of microprocessor technology for power system devices, such as primary measuring relays, monitoring devices, control systems, and telecommunications equipment.

Modern microprocessor-based relays have six significant traits that impact a maintenance strategy:

- Self-monitoring capability - the processors can check themselves, peripheral circuits, and some connected substation inputs and outputs, such as trip coil continuity. Most relay users are aware that these relays have self-monitoring, but are not focused on exactly what internal functions are actually being monitored. As explained further below, every element critical to the Protection System must be monitored, or else verified periodically.
- Ability to capture Fault records showing how the Protection System responded to a Fault in its zone of protection, or to a nearby Fault for which it is required not to operate.
- Ability to meter currents and voltages, as well as status of connected circuit breakers, continuously during non-Fault times. The relays can compute values, such as MW and Mvar line flows, that are sometimes used for operational purposes, such as SCADA.
- Data communications via ports that provide remote access to all of the results of Protection System monitoring, recording and measurement.
- Ability to trip or close circuit breakers and switches through the Protection System outputs, on command from remote data communications messages, or from relay front panel button requests.
- Construction from electronic components, some of which have shorter technical life or service life than electromechanical components of prior Protection System generations.

There have been significant advances in the technology behind the other components of Protection Systems. Microprocessors are now a part of battery chargers, associated communications equipment, voltage and current-measuring devices, and even the control circuitry (in the form of software-latches replacing lock-out relays, etc.).

Any Protection System component can have self-monitoring and alarming capability, not just relays. Because of this technology, extended time intervals for maintenance and inspection can find their way into all components of the Protection System.

This standard also recognizes the distinct advantage of using advanced technology to justifiably defer or even eliminate traditional maintenance. Just as a hand-held calculator does not require routine testing and calibration, neither does a calculation buried in a microprocessor-based

device that results in a “lock-out.” Thus, the software-latch 86 that replaces an electro-mechanical 86 does not require routine trip testing. Any trip circuitry associated with the “soft 86” would still need applicable verification activities performed, but the actual “86” does not have to be “electrically operated” or even toggled.

4. Definitions

Protection System Maintenance Program (PSMP) — An ongoing program by which Protection System, Automatic Reclosing and Sudden Pressure Relaying Components are kept in working order and proper operation of malfunctioning Components is restored. A maintenance program for a specific Component includes one or more of the following activities:

- Verify — Determine that the Component is functioning correctly.
- Monitor — Observe the routine in-service operation of the Component.
- Test — Apply signals to a Component to observe functional performance or output behavior, or to diagnose problems.
- Inspect — Examine for signs of Component failure, reduced performance and degradation.
- Calibrate — Adjust the operating threshold or measurement accuracy of a measuring element to meet the intended performance requirement.

Automatic Reclosing – Includes the following Components:

- Reclosing relay(s)
- Supervisory relay(s) or function(s) – relay(s) or function(s) that perform voltage and/or sync check functions that enables or disables operation of the reclosing relay
- Voltage sensing devices associated with the supervisory relay(s) or function(s)
- Control circuitry associated with the reclosing relay or supervisory relay(s) or function(s)

Sudden Pressure Relaying – A system that trips an interrupting device(s) to isolate the equipment it is monitoring and includes the following Components:

- Fault pressure relay – a mechanical relay or device that detects rapid changes in gas pressure, oil pressure, or oil flow that are indicative of faults within liquid-filled, wire-wound equipment
- Control circuitry associated with a fault pressure relay

Unresolved Maintenance Issue – A deficiency identified during a maintenance activity that causes the component to not meet the intended performance, cannot be corrected during the maintenance interval, and requires follow-up corrective action.

Segment – Components of a consistent design standard, or a particular model or type from a single manufacturer that typically share other common elements. Consistent performance is expected across the entire population of a Segment. A Segment must contain at least sixty (60) individual Components.

Component Type –

- Any one of the five specific elements of a Protection System.
- Any one of the four specific elements of Automatic Reclosing.
- Any one of the two specific elements of Sudden Pressure Relaying.

Component – Any individual discrete piece of equipment included in a Protection System, Automatic Reclosing, or Sudden Pressure Relaying.

Countable Event – A failure of a Component requiring repair or replacement, any condition discovered during the maintenance activities in Tables 1-1 through 1-5, Table 3, Tables 4-1 through 4-3, and Table 5, which requires corrective action or a Protection System Misoperation attributed to hardware failure or calibration failure. Misoperations due to product design errors, software errors, relay settings different from specified settings, Protection System Component, Automatic Reclosing or Sudden Pressure Relaying configuration or application errors are not included in Countable Events.

4.1 Frequently Asked Questions:

Why does PRC-005-6 not specifically require maintenance and testing procedures, as reflected in the previous standard, PRC-005-1?

PRC-005-1 does not require detailed maintenance and testing procedures, but instead requires summaries of such procedures, and is not clear on what is actually required. PRC-005-6 requires a documented maintenance program, and is focused on establishing requirements rather than prescribing methodology to meet those requirements. Between the activities identified in the Tables 1-1 through 1-5, Table 2, Table 3, and Table 4 (collectively the “Tables”), and the various components of the definition established for a “Protection System Maintenance Program,” PRC-005-6 establishes the activities and time basis for a Protection System Maintenance Program to a level of detail not previously required.

Please clarify what is meant by “restore” in the definition of maintenance.

The description of “restore” in the definition of a Protection System Maintenance Program addresses corrective activities necessary to assure that the component is returned to working order following the discovery of its failure or malfunction. The Maintenance Activities specified in the Tables do not present any requirements related to Restoration; Requirement R5 of the standard does require that the entity “shall demonstrate efforts to correct any identified Unresolved Maintenance Issues.” Some examples of restoration (or correction of Unresolved Maintenance Issues) include, but are not limited to, replacement of capacitors in distance relays to bring them to working order; replacement of relays, or other Protection System components, to bring the Protection System to working order; upgrade of electromechanical or solid-state protective relays to microprocessor-based relays following the discovery of failed components. Restoration, as used in this context, is not to be confused with restoration rules as used in system operations. Maintenance activity necessarily includes both the detection of problems and the repairs needed to eliminate those problems. This standard does not identify all of the Protection System problems that must be detected and eliminated, rather it is the intent of this standard that an entity determines the necessary working order for their various devices, and keeps them in working order. If an equipment item is repaired or replaced, then the entity can restart the maintenance-time-interval-clock, if desired; however, the replacement of equipment does not remove any documentation requirements that would have been required to verify compliance with time-interval requirements. In other words, do not discard maintenance data that goes to verify your work.

The retention of documentation for new and/or replaced equipment provides evidence that the maintenance intervals have been compliant. For example, a long-range plan of upgrades might lead an entity to ignore required maintenance; retaining the evidence of prior maintenance that existed before any retirements and upgrades proves compliance with the standard.

Please clarify what is meant by “...demonstrate efforts to correct an Unresolved Maintenance Issue...;” why not measure the completion of the corrective action?

Management of completion of the identified Unresolved Maintenance Issue is a complex topic that falls outside of the scope of this standard. There can be any number of supply, process and management problems that make setting repair deadlines impossible. The SDT specifically chose the phrase “demonstrate efforts to correct” (with guidance from NERC Staff) because of the concern that many more complex Unresolved Maintenance Issues might require greater than the remaining maintenance interval to resolve (and yet still be a “closed-end process”). For example, a problem might be identified on a VRLA battery during a six-month check. In instances such as one that requiring battery replacement as part of the long-term resolution, it is highly unlikely that the battery could be replaced in time to meet the six-calendar-month requirement for this maintenance activity. The SDT does not believe entities should be found in violation of a maintenance program requirement because of the inability to complete a remediation program within the original maintenance interval. The SDT does believe corrective actions should be timely, but concludes it would be impossible to postulate all possible remediation projects; and, therefore, impossible to specify bounding time frames for resolution of all possible Unresolved Maintenance Issues, or what documentation might be sufficient to provide proof that effective corrective action is being undertaken.

5. Time-Based Maintenance (TBM) Programs

Time-based maintenance is the process in which Protection System, Automatic Reclosing and Sudden Pressure Relaying Components are maintained or verified according to a time schedule. The scheduled program often calls for technicians to travel to the physical site and perform a functional test on Protection System components. However, some components of a TBM program may be conducted from a remote location—for example, tripping a circuit breaker by communicating a trip command to a microprocessor relay to determine if the entire Protection System tripping chain is able to operate the breaker. Similarly, all Protection System, and Sudden Pressure Relaying Components, can have the ability to remotely conduct tests, either on-command or routinely; the running of these tests can extend the time interval between hands-on maintenance activities.

5.1 Maintenance Practices

Maintenance and testing programs often incorporate the following types of maintenance practices:

- TBM – time-based maintenance – externally prescribed maximum maintenance or testing intervals are applied for components or groups of components. The intervals may have been developed from prior experience or manufacturers’ recommendations. The TBM verification interval can be based on a variety of factors, including experience of the particular asset owner, collective experiences of several asset owners who are members of a country or regional council, etc. The maintenance intervals are fixed and may range in number from months to years.

TBM can include review of recent power system events near the particular terminal. Operating records may verify that some portion of the Protection System has operated correctly since the last test occurred. If specific protection scheme components have demonstrated correct performance within specifications, the maintenance test time clock can be reset for those components.

- PBM – Performance-Based Maintenance - intervals are established based on analytical or historical results of TBM failure rates on a statistically significant population of similar components. Some level of TBM is generally followed. Statistical analyses accompanied by adjustments to maintenance intervals are used to justify continued use of PBM-developed extended intervals when test failures or in-service failures occur infrequently.
- CBM – condition-based maintenance – continuously or frequently reported results from non-disruptive self-monitoring of components demonstrate operational status as those components remain in service. Whatever is verified by CBM does not require manual testing, but taking advantage of this requires precise technical focus on exactly what parts are included as part of the self-diagnostics. While the term “Condition-Based-Maintenance” (CBM) is no longer used within the standard itself, it is important to note that the concepts of CBM are a part of the standard (in the form of extended time intervals through status-monitoring). These extended time intervals are only allowed (in the absence of PBM) if the condition of the device is continuously monitored. As a consequence of the “monitored-basis-time-intervals” existing within the standard, the

explanatory discussions within this Supplementary Reference concerned with CBM will remain in this reference and are discussed as CBM.

Microprocessor-based Protection System or Automatic Reclosing Components that perform continuous self-monitoring verify correct operation of most components within the device. Self-monitoring capabilities may include battery continuity, float voltages, unintentional grounds, the ac signal inputs to a relay, analog measuring circuits, processors and memory for measurement, protection, and data communications, trip circuit monitoring, and protection or data communications signals (and many, many more measurements). For those conditions, failure of a self-monitoring routine generates an alarm and may inhibit operation to avoid false trips. When internal components, such as critical output relay contacts, are not equipped with self-monitoring, they can be manually tested. The method of testing may be local or remote, or through inherent performance of the scheme during a system event.

The TBM is the overarching maintenance process of which the other types are subsets. Unlike TBM, PBM intervals are adjusted based on good or bad experiences. The CBM verification intervals can be hours, or even milliseconds between non-disruptive self-monitoring checks within or around components as they remain in service.

TBM, PBM, and CBM can be combined for individual components, or within a complete Protection System. The following diagram illustrates the relationship between various types of maintenance practices described in this section. In the Venn diagram, the overlapping regions show the relationship of TBM with PBM historical information and the inherent continuous monitoring offered through CBM.

This figure shows:

- Region 1: The TBM intervals that are increased based on known reported operational condition of individual components that are monitoring themselves.
- Region 2: The TBM intervals that are adjusted up or down based on results of analysis of maintenance history of statistically significant population of similar products that have been subject to TBM.
- Region 3: Optimal TBM intervals based on regions 1 and 2.

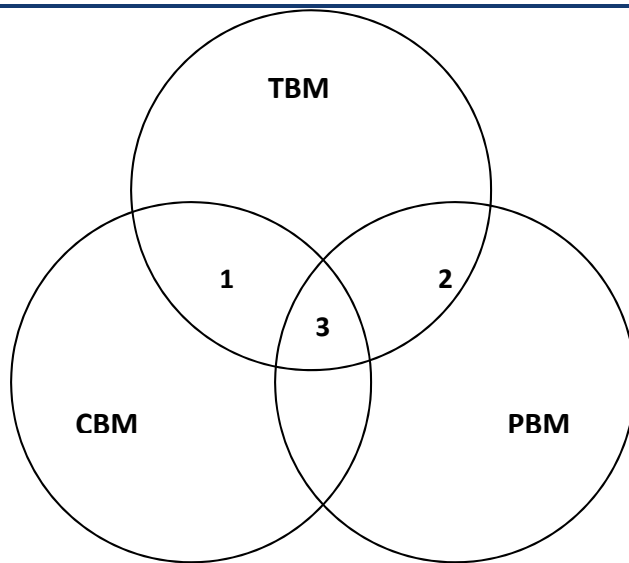

Relationship of time-based maintenance types

5.1.1 Frequently Asked Questions:

The standard seems very complicated, and is difficult to understand. Can it be simplified?

Because the standard is establishing parameters for condition-based Maintenance (Requirement R1) and Performance-Based Maintenance (Requirement R2), in addition to simple time-based Maintenance, it does appear to be complicated. At its simplest, an entity needs to ONLY perform time-based maintenance according to the unmonitored rows of the Tables. If an entity then wishes to take advantage of monitoring on its Protection System components and its available lengthened time intervals, then it may, as long as the component has the listed monitoring attributes. If an entity wishes to use historical performance of its Protection System components to perform Performance-Based Maintenance, then Requirement R2 applies.

Please see the following diagram, which provides a “flow chart” of the standard.

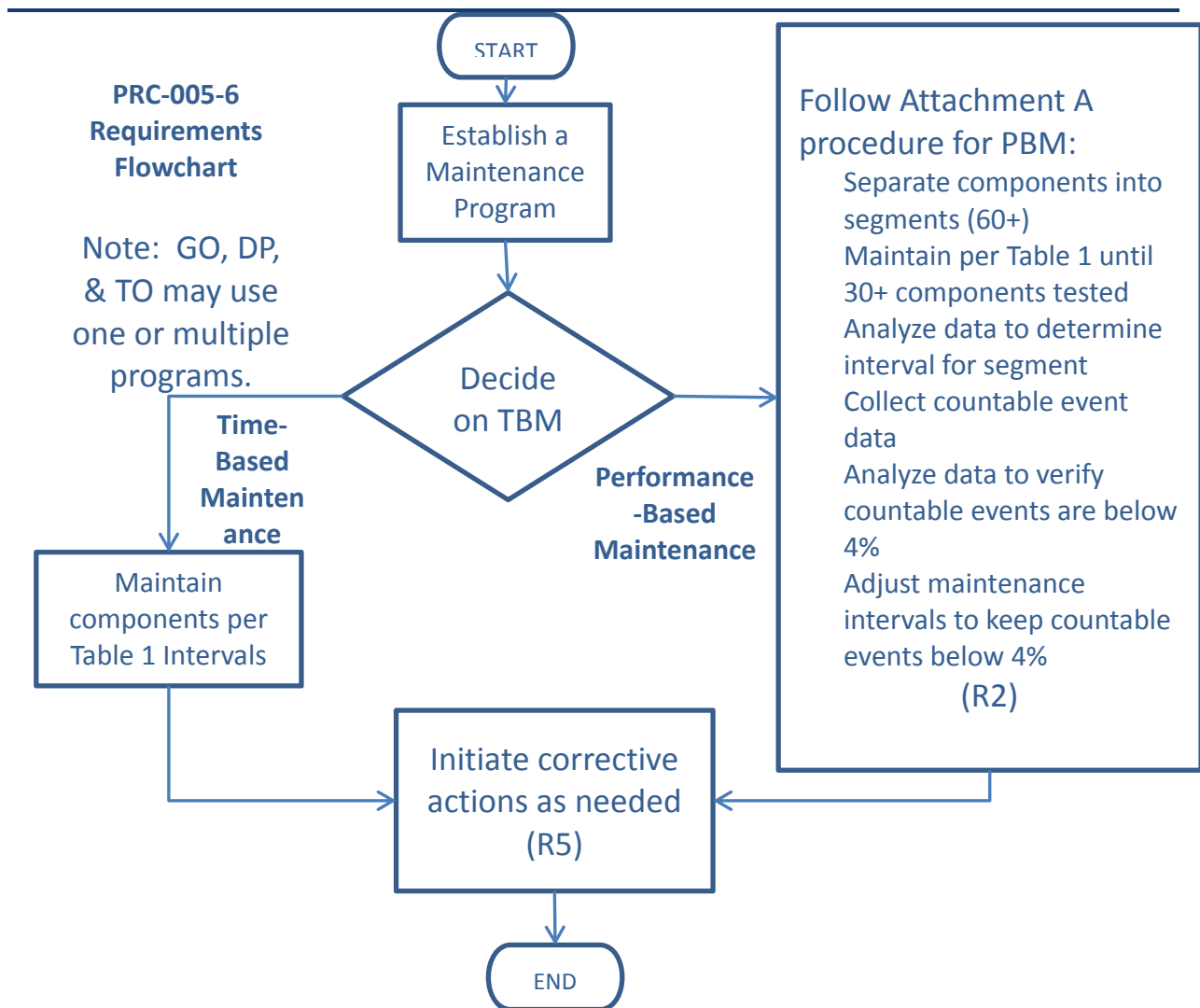

We have an electromechanical (unmonitored) relay that has a trip output to a lockout relay (unmonitored) which trips our transformer off-line by tripping the transformer's high-side and low-side circuit breakers. What testing must be done for this system?

This system is made up of components that are all unmonitored. Assuming a time-based Protection System Maintenance Program schedule (as opposed to a Performance-Based maintenance program), each component must be maintained per the most frequent hands-on activities listed in the Tables.

5.2 Extending Time-Based Maintenance

All maintenance is fundamentally time-based. Default time-based intervals are commonly established to assure proper functioning of each component of the Protection System, when data on the reliability of the components is not available other than observations from time-based maintenance. The following factors may influence the established default intervals:

- If continuous indication of the functional condition of a component is available (from relays or chargers or any self-monitoring device), then the intervals may be extended, or manual testing may be eliminated. This is referred to as condition-based maintenance or CBM. CBM is valid only for precisely the components subject to monitoring. In the case

of microprocessor-based relays, self-monitoring may not include automated diagnostics of every component within a microprocessor.

- Previous maintenance history for a group of components of a common type may indicate that the maintenance intervals can be extended, while still achieving the desired level of performance. This is referred to as Performance-Based Maintenance, or PBM. It is also sometimes referred to as reliability-centered maintenance, or RCM; but PBM is used in this document.
- Observed proper operation of a component may be regarded as a maintenance verification of the respective component or element in a microprocessor-based device. For such an observation, the maintenance interval may be reset only to the degree that can be verified by data available on the operation. For example, the trip of an electromechanical relay for a Fault verifies the trip contact and trip path, but only through the relays in series that actually operated; one operation of this relay cannot verify correct calibration.

Excessive maintenance can actually decrease the reliability of the component or system. It is not unusual to cause failure of a component by removing it from service and restoring it. The improper application of test signals may cause failure of a component. For example, in electromechanical overcurrent relays, test currents have been known to destroy convolution springs.

In addition, maintenance usually takes the component out of service, during which time it is not able to perform its function. Cutout switch failures, or failure to restore switch position, commonly lead to protection failures.

5.2.1 Frequently Asked Questions:

If I show the protective device out of service while it is being repaired, then can I add it back as a new protective device when it returns? If not, my relay testing history would show that I was out of compliance for the last maintenance cycle.

The maintenance and testing requirements (R5) (in essence) state "...shall demonstrate efforts to correct identified Unresolved Maintenance Issues." The type of corrective activity is not stated; however, it could include repairs or replacements.

Your documentation requirements will increase, of course, to demonstrate that your device test failed and had corrective actions initiated. Your regional entity will likely request documentation showing the status of your corrective actions.

6. Condition-Based Maintenance (CBM) Programs

Condition-based maintenance is the process of gathering and monitoring the information available from modern microprocessor-based relays and other intelligent electronic devices (IEDs) that monitor Protection System or Automatic Reclosing elements. These devices generate monitoring information during normal operation, and the information can be assessed at a convenient location remote from the substation. The information from these relays and IEDs is divided into two basic types:

1. Information can come from background self-monitoring processes, programmed by the manufacturer, or by the user in device logic settings. The results are presented by alarm contacts or points, front panel indications, and by data communications messages.
2. Information can come from event logs, captured files, and/or oscillographic records for Faults and Disturbances, metered values, and binary input status reports. Some of these are available on the device front panel display, but may be available via data communications ports. Large files of Fault information can only be retrieved via data communications. These results comprise a mass of data that must be further analyzed for evidence of the operational condition of the Protection System.

Using these two types of information, the user can develop an effective maintenance program carried out mostly from a central location remote from the substation. This approach offers the following advantages:

Non-invasive Maintenance: The system is kept in its normal operating state, without human intervention for checking. This reduces risk of damage, or risk of leaving the system in an inoperable state after a manual test. Experience has shown that keeping human hands away from equipment known to be working correctly enhances reliability.

Virtually Continuous Monitoring: CBM will report many hardware failure problems for repair within seconds or minutes of when they happen. This reduces the percentage of problems that are discovered through incorrect relaying performance. By contrast, a hardware failure discovered by TBM may have been present for much of the time interval between tests, and there is a good chance that some devices will show health problems by incorrect operation before being caught in the next test round. The frequent or continuous nature of CBM makes the effective verification interval far shorter than any required TBM maximum interval. To use the extended time intervals available through Condition Based Maintenance, simply look for the rows in the Tables that refer to monitored items.

6.1 Frequently Asked Questions:

My microprocessor relays and dc circuit alarms are contained on relay panels in a 24-hour attended control room. Does this qualify as an extended time interval condition-based (monitored) system?

Yes, provided the station attendant (plant operator, etc.) monitors the alarms and other indications (comparable to the monitoring attributes) and reports them within the given time limits that are stated in the criteria of the Tables.

When documenting the basis for inclusion of components into the appropriate levels of monitoring, as per Requirement R1 (Part 1.2) of the standard, is it necessary to

provide this documentation about the device by listing of every component and the specific monitoring attributes of each device?

No--While maintaining this documentation on the device level would certainly be permissible, it is not necessary. Global statements can be made to document appropriate levels of monitoring for the entire population of a component type or portion thereof.

For example, it would be permissible to document the conclusion that all BES substation dc supply battery chargers are monitored by stating the following within the program description:

“All substation dc supply battery chargers are considered monitored and subject to the rows for monitored equipment of Table 1-4 requirements, as all substation dc supply battery chargers are equipped with dc voltage alarms and ground detection alarms that are sent to the manned control center.”

Similarly, it would be acceptable to use a combination of a global statement and a device-level list of exclusions. Example:

“Except as noted below, all substation dc supply battery chargers are considered monitored and subject to the rows for monitored equipment of Table 1-4 requirements, as all substation dc supply battery chargers are equipped with dc voltage alarms and ground detection alarms that are sent to the manned control center. The dc supply battery chargers of Substation X, Substation Y, and Substation Z are considered unmonitored and subject to the rows for unmonitored equipment in Table 1-4 requirements, as they are not equipped with ground detection capability.”

Regardless whether this documentation is provided by device listing of monitoring attributes, by global statements of the monitoring attributes of an entire population of component types, or by some combination of these methods, it should be noted that auditors may request supporting drawings or other documentation necessary to validate the inclusion of the device(s) within the appropriate level of monitoring. This supporting background information need not be maintained within the program document structure, but should be retrievable if requested by an auditor.

7. Time-Based Versus Condition-Based Maintenance

Time-based and condition-based (or monitored) maintenance programs are both acceptable, if implemented according to technically sound requirements. Practical programs can employ a combination of time-based and condition-based maintenance. The standard requirements introduce the concept of optionally using condition monitoring as a documented element of a maintenance program.

The Federal Energy Regulatory Commission (FERC), in its Order Number 693 Final Rule, dated March 16, 2007 (18 CFR Part 40, Docket No. RM06-16-000) on Mandatory Reliability Standards for the Bulk-Power System, directed NERC to submit a modification to PRC-005-1b that includes a requirement that maintenance and testing of a Protection System must be carried out within a maximum allowable interval that is appropriate to the type of the Protection System and its impact on the reliability of the Bulk Power System. Accordingly, this Supplementary Reference Paper refers to the specific maximum allowable intervals in PRC-005-6. The defined time limits allow for longer time intervals if the maintained component is monitored.

A key feature of condition-based monitoring is that it effectively reduces the time delay between the moment of a protection failure and time the Protection System or Automatic Reclosing owner knows about it, for the monitored segments of the Protection System. In some cases, the verification is practically continuous--the time interval between verifications is minutes or seconds. Thus, technically sound, condition-based verification, meets the verification requirements of the FERC order even more effectively than the strictly time-based tests of the same system components.

The result is that:

This NERC standard permits applicable entities to use a technically sound approach and to take advantage of remote monitoring, data analysis, and control capabilities of modern Protection System and Automatic Reclosing Components to reduce the need for periodic site visits and invasive testing of components by on-site technicians. This periodic testing must be conducted within the maximum time intervals specified in the Tables of PRC-005-6.

7.1 Frequently Asked Questions:

What is a Calendar Year?

Calendar Year - January 1 through December 31 of any year. As an example, if an event occurred on June 17, 2009 and is on a "One Calendar Year Interval," the next event would have to occur on or before December 31, 2010.

Please provide an example of "4 Calendar Months".

If a maintenance activity is described as being needed every four Calendar Months then it is performed in a (given) month and due again four months later. For example a battery bank is inspected in month number 1 then it is due again before the end of the month number 5. And specifically consider that you perform your battery inspection on January 3 then it must be inspected again before the end of May. Another example could be that a four-month inspection was performed in January is due in May, but if performed in March (instead of May) would still

be due four months later therefore the activity is due again July. Basically every “four Calendar Months” means to add four months from the last time the activity was performed and perform the activity by the end of the fourth month.

Please provide an example of the unmonitored versus other levels of monitoring available?

An unmonitored Protection System has no monitoring and alarm circuits on the Protection System components. A Protection System component that has monitoring attributes but no alarm output connected is considered to be unmonitored.

A monitored Protection System or an individual monitored component of a Protection System has monitoring and alarm circuits on the Protection System components. The alarm circuits must alert, within 24 hours, a location wherein corrective action can be initiated. This location might be, but is not limited to, an Operations Center, Dispatch Office, Maintenance Center or even a portable SCADA system.

There can be a combination of monitored and unmonitored Protection Systems within any given scheme, substation or plant; there can also be a combination of monitored and unmonitored components within any given Protection System.

Example #1: A combination of monitored and unmonitored components within a given Protection System might be:

- A microprocessor relay with an internal alarm connected to SCADA to alert 24-hr staffed operations center; it has internal self-diagnosis and alarming. (monitored)
- Instrumentation transformers, with no monitoring, connected as inputs to that relay. (unmonitored)
- A vented Lead-Acid battery with a low voltage alarm for the station dc supply voltage and an unintentional grounds detection alarm connected to SCADA. (monitoring varies)
- A circuit breaker with a trip coil, and the trip circuit is not monitored. (unmonitored)

Given the particular components and conditions, and using Table 1 and Table 2, the particular components have maximum activity intervals of:

Every four calendar months, inspect:

- Electrolyte level (station dc supply voltage and unintentional ground detection is being maintained more frequently by the monitoring system).

Every 18 calendar months, verify/inspect the following:

- Battery bank ohmic values to station battery baseline (if performance tests are not opted)
- Battery charger float voltage
- Battery rack integrity
- Cell condition of all individual battery cells (where visible)
- Battery continuity

-
- Battery terminal connection resistance
 - Battery cell-to-cell resistance (where available to measure)

Every six calendar years, perform/verify the following:

- Battery performance test (if internal ohmic tests or other measurements indicative of battery performance are not opted)
- Verify that each trip coil is able to operate the circuit breaker, interrupting device, or mitigating device
- For electromechanical lock-out relays, electrical operation of electromechanical trip

Every 12 calendar years, verify the following:

- Microprocessor relay settings are as specified
- Operation of the microprocessor's relay inputs and outputs that are essential to proper functioning of the Protection System
- Acceptable measurement of power System input values seen by the microprocessor protective relay
- Verify that current and voltage signal values are provided to the protective relays
- Protection System component monitoring for the battery system signals are conveyed to a location where corrective action can be initiated
- The microprocessor relay alarm signals are conveyed to a location where corrective action can be initiated
- Verify all trip paths in the control circuitry associated with protective functions through the trip coil(s) of the circuit breakers or other interrupting devices
- Auxiliary outputs that are in the trip path shall be maintained as detailed in Table 1-5 of the standard under the 'Unmonitored Control Circuitry Associated with Protective Functions' section'
- Auxiliary outputs not in a trip path (i.e., annunciation or DME input) are not required, by this standard, to be checked

Example #2: A combination of monitored and unmonitored components within a given Protection System might be:

- A microprocessor relay with integral alarm that is not connected to SCADA. (unmonitored)
- Current and voltage signal values, with no monitoring, connected as inputs to that relay. (unmonitored)
- A vented lead-acid battery with a low voltage alarm for the station dc supply voltage and an unintentional grounds detection alarm connected to SCADA. (monitoring varies)
- A circuit breaker with a trip coil, with no circuits monitored. (unmonitored)

Given the particular components and conditions, and using the Table 1 (Maximum Allowable Testing Intervals and Maintenance Activities) and Table 2 (Alarming Paths and Monitoring), the particular components have maximum activity intervals of:

Every four calendar months, inspect:

- Electrolyte level (station dc supply voltage and unintentional ground detection is being maintained more frequently by the monitoring system)

Every 18 calendar months, verify/inspect the following:

- Battery bank trending of ohmic values or other measurements indicative of battery performance to station battery baseline (if performance tests are not opted)
- Battery charger float voltage
- Battery rack integrity
- Cell condition of all individual battery cells (where visible)
- Battery continuity
- Battery terminal connection resistance
- Battery cell-to-cell resistance (where available to measure)

Every six calendar years, verify/perform the following:

- Verify operation of the relay inputs and outputs that are essential to proper functioning of the Protection System
- Verify acceptable measurement of power system input values as seen by the relays
- Verify that each trip coil is able to operate the circuit breaker, interrupting device, or mitigating device
- For electromechanical lock-out relays, electrical operation of electromechanical trip
- Battery performance test (if internal ohmic tests are not opted)

Every 12 calendar years, verify the following:

- Current and voltage signal values are provided to the protective relays
- Protection System component monitoring for the battery system signals are conveyed to a location where corrective action can be initiated
- All trip paths in the control circuitry associated with protective functions through the trip coil(s) of the circuit breakers or other interrupting devices
- Auxiliary outputs that are in the trip path shall be maintained, as detailed in Table 1-5 of the standard under the Unmonitored Control Circuitry Associated with Protective Functions" section
- Auxiliary outputs not in a trip path (i.e., annunciation or DME input) are not required, by this standard, to be checked

Example #3: A combination of monitored and unmonitored components within a given Protection System might be:

- A microprocessor relay with alarm connected to SCADA to alert 24-hr staffed operations center; it has internal self-diagnosis and alarms. (monitored)
- Current and voltage signal values, with monitoring, connected as inputs to that relay (monitored)
- Vented Lead-Acid battery without any alarms connected to SCADA (unmonitored)
- Circuit breaker with a trip coil, with no circuits monitored (unmonitored)

Given the particular components, conditions, and using the Table 1 (Maximum Allowable Testing Intervals and Maintenance Activities) and Table 2 (Alarming Paths and Monitoring), the particular components shall have maximum activity intervals of:

Every four calendar months, verify/inspect the following:

- Station dc supply voltage
- For unintentional grounds
- Electrolyte level

Every 18 calendar months, verify/inspect the following:

- Battery bank trending of ohmic values or other measurements indicative of battery performance to station battery baseline (if performance tests are not opted)
- Battery charger float voltage
- Battery rack integrity
- Battery continuity
- Battery terminal connection resistance
- Battery cell-to-cell resistance (where available to measure)
- Condition of all individual battery cells (where visible)

Every six calendar years, perform/verify the following:

- Battery performance test (if internal ohmic tests or other measurements indicative of battery performance are not opted)
- Verify that each trip coil is able to operate the circuit breaker, interrupting device, or mitigating device
- For electromechanical lock-out relays, electrical operation of electromechanical trip

Every 12 calendar years, verify the following:

- The microprocessor relay alarm signals are conveyed to a location where corrective action can be taken
- Microprocessor relay settings are as specified
- Operation of the microprocessor's relay inputs and outputs that are essential to proper functioning of the Protection System

-
- Acceptable measurement of power system input values seen by the microprocessor protective relay
 - Verify all trip paths in the control circuitry associated with protective functions through the trip coil(s) of the circuit breakers or other interrupting devices
 - Auxiliary outputs that are in the trip path shall be maintained, as detailed in Table 1-5 of the standard under the Unmonitored Control Circuitry Associated with Protective Functions section
 - Auxiliary outputs not in a trip path (i.e. annunciation or DME input) are not required, by this standard, to be checked

Why do components have different maintenance activities and intervals if they are monitored?

The rationale supporting different activities and intervals for monitored equipment is to allow less frequent manual intervention when more information is known about the condition of Protection System components. Condition-Based Maintenance is a valuable asset to improve reliability.

Can all components in a Protection System be monitored?

No--For some components in a Protection System, monitoring will not be relevant. For example, a battery will always need some kind of inspection.

We have a 30-year-old oil circuit breaker with a red indicating lamp on the substation relay panel that is illuminated only if there is continuity through the breaker trip coil. There is no SCADA monitor or relay monitor of this trip coil. The line protection relay package that trips this circuit breaker is a microprocessor relay that has an integral alarm relay that will assert on a number of conditions that includes a loss of power to the relay. This alarm contact connects to our SCADA system and alerts our 24-hour operations center of relay trouble when the alarm contact closes. This microprocessor relay trips the circuit breaker only and does not monitor trip coil continuity or other things such as trip current. Are the components monitored or not? How often must I perform maintenance?

The protective relay is monitored and can be maintained every 12 years, or when an Unresolved Maintenance Issue arises. The control circuitry can be maintained every 12 years. The circuit breaker trip coil(s) has to be electrically operated at least once every six years.

What is a mitigating device?

A mitigating device is the device that acts to respond as directed by a Remedial Action Schemes. It may be a breaker, valve, distributed control system, or any variety of other devices. This response may include tripping, closing, or other control actions.

8. Maximum Allowable Verification Intervals

The maximum allowable testing intervals and maintenance activities show how CBM with newer device types can reduce the need for many of the tests and site visits that older Protection System components require. As explained below, there are some sections of the Protection System that monitoring or data analysis may not verify. Verifying these sections of the Protection System or Automatic Reclosing requires some persistent TBM activity in the maintenance program. However, some of this TBM can be carried out remotely--for example, exercising a circuit breaker through the relay tripping circuits using the relay remote control capabilities can be used to verify function of one tripping path and proper trip coil operation, if there has been no Fault or routine operation to demonstrate performance of relay tripping circuits.

8.1 Maintenance Tests

Periodic maintenance testing is performed to ensure that the protection and control system is operating correctly after a time period of field installation. These tests may be used to ensure that individual components are still operating within acceptable performance parameters - this type of test is needed for components susceptible to degraded or changing characteristics due to aging and wear. Full system performance tests may be used to confirm that the total Protection System functions from measurement of power system values, to properly identifying Fault characteristics, to the operation of the interrupting devices.

8.1.1 Table of Maximum Allowable Verification Intervals

Table 1 (collectively known as Table 1, individually called out as Tables 1-1 through 1-5), Table 2, Table 3, Table 4-1 through Table 4-3, and Table 5 in the standard specify maximum allowable verification intervals for various generations of Protection Systems, Automatic Reclosing and Sudden Pressure Relaying and categories of equipment that comprise these systems. The right column indicates maintenance activities required for each category.

The types of components are illustrated in [Figures 1](#) and [2](#) at the end of this paper. Figure 1 shows an example of telecommunications-assisted transmission Protection System comprising substation equipment at each terminal and a telecommunications channel for relaying between the two substations. [Figure 2](#) shows an example of a generation Protection System. The various sub-systems of a Protection System that need to be verified are shown.

Non-distributed UFLS, UVLS, and RAS are additional categories of Table 1 that are not illustrated in these figures. Non-distributed UFLS, UVLS and RAS all use identical equipment as Protection Systems in the performance of their functions; and, therefore, have the same maintenance needs.

Distributed UFLS and UVLS Systems, which use local sensing on the distribution System and trip co-located non-BES interrupting devices, are addressed in Table 3 with reduced maintenance activities.

While it is easy to associate protective relays to multiple levels of monitoring, it is also true that most of the components that can make up a Protection System can also have technological advancements that place them into higher levels of monitoring.

To use the Maintenance Activities and Intervals Tables from PRC-005-6:

-
- First find the Table associated with your component. The tables are arranged in the order of mention in the definition of Protection System;
 - Table 1-1 is for protective relays.
 - Table 1-2 is for the associated communications systems.
 - Table 1-3 is for current and voltage sensing devices.
 - Table 1-4 is for station dc supply.
 - Table 1-5 is for control circuits.
 - Table 2, is for alarms; this was broken out to simplify the other tables.
 - Table 3 is for components which make-up distributed UFLS and UVLS Systems.
 - Table 4 is for Automatic Reclosing.
 - Table 5 is for Sudden Pressure Relaying.
 - Next, look within that table for your device and its degree of monitoring. The Tables have different hands-on maintenance activities prescribed depending upon the degree to which you monitor your equipment. Find the maintenance activity that applies to the monitoring level that you have on your piece of equipment.
 - This Maintenance activity is the minimum maintenance activity that must be documented.
 - If your Performance-Based Maintenance (PBM) plan requires more activities, then you must perform and document to this higher standard. (Note that this does not apply unless you utilize PBM.)
 - After the maintenance activity is known, check the maximum maintenance interval; this time is the maximum time allowed between hands-on maintenance activity cycles of this component.
 - If your Performance-Based Maintenance plan requires activities more often than the Tables maximum, then you must perform and document those activities to your more stringent standard. (Note that this does not apply unless you utilize PBM.)
 - Any given component of a Protection System can be determined to have a degree of monitoring that may be different from another component within that same Protection System. For example, in a given Protection System it is possible for an entity to have a monitored protective relay and an unmonitored associated communications system; this combination would require hands-on maintenance activity on the relay at least once every 12 years and attention paid to the communications system as often as every four months.
 - An entity does not have to utilize the extended time intervals made available by this use of condition-based monitoring. An easy choice to make is to simply utilize the unmonitored level of maintenance made available in each of the Tables. While the maintenance activities resulting from this choice would require more maintenance man-

hours, the maintenance requirements may be simpler to document and the resulting maintenance plans may be easier to create.

For each Protection System Component, Table 1 shows maximum allowable testing intervals for the various degrees of monitoring. For each Automatic Reclosing Component, Table 4 shows maximum allowable testing intervals for the various degrees of monitoring. These degrees of monitoring, or levels, range from the legacy unmonitored through a system that is more comprehensively monitored.

It has been noted here that an entity may have a PSMP that is more stringent than PRC-005-6. There may be any number of reasons that an entity chooses a more stringent plan than the minimums prescribed within PRC-005-6, most notable of which is an entity using performance based maintenance methodology.

If an entity has a Performance-Based Maintenance program, then that plan must be followed, even if the plan proves to be more stringent than the minimums laid out in the Tables.

If an entity has a Time-Based Maintenance program and the PSMP is more stringent than PRC-005-6, they will only be audited in accordance with the standard (minimum maintenance activities and maximum maintenance intervals prescribed within Tables 1-1 through 1-5, Table 2, Table 3, Table 4-1 through 4-3, and Table 5).

8.1.2 Additional Notes for Tables 1-1 through 1-5, Table 3, and Table 4

1. For electromechanical relays, adjustment is required to bring measurement accuracy within the tolerance needed by the asset owner. Microprocessor relays with no remote monitoring of alarm contacts, etc., are unmonitored relays and need to be verified within the Table interval as other unmonitored relays but may be verified as functional by means other than testing by simulated inputs.
2. Microprocessor relays typically are specified by manufacturers as not requiring calibration, but acceptable measurement of power system input values must be verified (verification of the Analog to Digital [A/D] converters) within the Table intervals. The integrity of the digital inputs and outputs that are used as protective functions must be verified within the Table intervals.
3. Any Phasor Measurement Unit (PMU) function whose output is used in a Protection System or RAS (as opposed to a monitoring task) must be verified as a component in a Protection System.
4. In addition to verifying the circuitry that supplies dc to the Protection System, the owner must maintain the station dc supply. The most widespread station dc supply is the station battery and charger. Unlike most Protection System components, physical inspection of station batteries for signs of component failure, reduced performance, and degradation are required to ensure that the station battery is reliable enough to deliver dc power when required. IEEE Standards 450, 1188, and 1106 for vented lead-acid, valve-regulated lead-acid, and nickel-cadmium batteries, respectively (which are the most commonly used substation batteries on the NERC BES) have been developed as an important reference source of maintenance recommendations. The Protection System owner might want to follow the guidelines in the applicable IEEE recommended practices for battery maintenance and testing, especially if the battery in question is used for application requirements in addition to the protection and control demands covered under this

standard. However, the Standard Drafting Team has tailored the battery maintenance and testing guidelines in PRC-005-6 for the Protection System owner which are application specific for the BES Facilities. While the IEEE recommendations are all encompassing, PRC-005-6 is a more economical approach while addressing the reliability requirements of the BES.

5. Aggregated small entities might distribute the testing of the population of UFLS/UVLS systems, and large entities will usually maintain a portion of these systems in any given year. Additionally, if relatively small quantities of such systems do not perform properly, it will not affect the integrity of the overall program. Thus, these distributed systems have decreased requirements as compared to other Protection Systems.
6. Voltage and current sensing device circuit input connections to the Protection System relays can be verified by (but not limited to) comparison of measured values on live circuits or by using test currents and voltages on equipment out of service for maintenance. The verification process can be automated or manual. The values should be verified to be as expected (phase value and phase relationships are both equally important to verify).
7. “End-to-end test,” as used in this Supplementary Reference, is any testing procedure that creates a remote input to the local communications-assisted trip scheme. While this can be interpreted as a GPS-type functional test, it is not limited to testing via GPS. Any remote scheme manipulation that can cause action at the local trip path can be used to functionally-test the dc control circuitry. A documented Real-time trip of any given trip path is acceptable in lieu of a functional trip test. It is possible, with sufficient monitoring, to be able to verify each and every parallel trip path that participated in any given dc control circuit trip. Or another possible solution is that a single trip path from a single monitored relay can be verified to be the trip path that successfully tripped during a Real-time operation. The variations are only limited by the degree of engineering and monitoring that an entity desires to pursue.
8. A/D verification may use relay front panel value displays, or values gathered via data communications. Groupings of other measurements (such as vector summation of bus feeder currents) can be used for comparison if calibration requirements assure acceptable measurement of power system input values.
9. Notes 1-8 attempt to describe some testing activities; they do not represent the only methods to achieve these activities, but rather some possible methods. Technological advances, ingenuity and/or industry accepted techniques can all be used to satisfy maintenance activity requirements; the standard is technology- and method-neutral in most cases.

8.1.3 Frequently Asked Questions:

What is meant by “Verify that settings are as specified” maintenance activity in Table 1-1?

Verification of settings is an activity directed mostly towards microprocessor- based relays. For relay maintenance departments that choose to test microprocessor-based relays in the same manner as electromechanical relays are tested, the testing process sometimes requires

that some specific functions be disabled. Later tests might enable the functions previously disabled, but perhaps still other functions or logic statements were then masked out. It is imperative that, when the relay is placed into service, the settings in the relay be the settings that were intended to be in that relay or as the standard states "...settings are as specified."

Many of the microprocessor-based relays available today have software tools which provide this functionality and generate reports for this purpose.

For evidence or documentation of this requirement, a simple recorded acknowledgement that the settings were checked to be as specified is sufficient.

The drafting team was careful not to require "...that the relay settings be correct..." because it was believed that this might then place a burden of proof that the specified settings would result in the correct intended operation of the interrupting device. While that is a noble intention, the measurable proof of such a requirement is immense. The intent is that settings of the component be as specified at the conclusion of maintenance activities, whether those settings may have "drifted" since the prior maintenance or whether changes were made as part of the testing process.

Are electromechanical relays included in the "Verify that settings are as specified" maintenance activity in Table 1-1?

Verification of settings is an activity directed towards the application of protection related functions of microprocessor based relays. Electromechanical relays require calibration verification by voltage and/or current injection; and, thus, the settings are verified during calibration activity. In the example of a time-overcurrent relay, a minor deviation in time dial, versus the settings, may be acceptable, as long as the relay calibration is within accepted tolerances at the injected current amplitudes. A major deviation may require further investigation, as it could indicate a problem with the relay or an incorrect relay style for the application.

The verification of phase current and voltage measurements by comparison to other quantities seems reasonable. How, though, can I verify residual or neutral currents, or 3V0 voltages, by comparison, when my system is closely balanced?

Since these inputs are verified at commissioning, maintenance verification requires ensuring that phase quantities are as expected and that 3IO and 3VO quantities appear equal to or close to 0.

These quantities also may be verified by use of oscillographic records for connected microprocessor relays as recorded during system Disturbances. Such records may compare to similar values recorded at other locations by other microprocessor relays for the same event, or compared to expected values (from short circuit studies) for known Fault locations.

What does this Standard require for testing an auxiliary tripping relay?

Table 1 and Table 3 requires that a trip test must verify that the auxiliary tripping relay(s) and/or lockout relay(s) which are directly in a trip path from the protective relay to the interrupting device trip coil operate(s) electrically. Auxiliary outputs not in a trip path (i.e. annunciation or DME input) are not required, by this standard, to be checked.

Do I have to perform a full end-to-end test of a Remedial Action Schemes?

No--all portions of the RAS need to be maintained, and the portions must overlap, but the overall RAS does not need to have a single end-to-end test. In other words it may be tested in piecemeal fashion provided all of the pieces are verified.

What about RAS interfaces between different entities or owners?

As in all of the Protection System requirements, RAS segments can be tested individually, thus minimizing the need to accommodate complex maintenance schedules.

What do I have to do if I am using a phasor measurement unit (PMU) as part of a Protection System or Remedial Action Schemes?

Any Phasor Measurement Unit (PMU) function whose output is used in a Protection System or Remedial Action Schemes (as opposed to a monitoring task) must be verified as a component in a Protection System.

How do I maintain a Remedial Action Schemes or relay sensing for non-distributed UFLS or UVLS Systems?

Since components of the RAS, UFLS and UVLS are the same types of components as those in Protection Systems, then these components should be maintained like similar components used for other Protection System functions. In many cases the devices for RAS, UFLS and UVLS are also used for other protective functions. The same maintenance activities apply with the exception that distributed systems (UFLS and UVLS) have fewer dc supply and control circuitry maintenance activity requirements.

For the testing of the output action, verification may be by breaker tripping, but may be verified in overlapping segments. For example, an RAS that trips a remote circuit breaker might be tested by testing the various parts of the scheme in overlapping segments. Another method is to document the Real-time tripping of an RAS scheme should that occur. Forced trip tests of circuit breakers (etc.) that are a part of distributed UFLS or UVLS schemes are not required.

The established maximum allowable intervals do not align well with the scheduled outages for my power plant. Can I extend the maintenance to the next scheduled outage following the established maximum interval?

No--you must complete your maintenance within the established maximum allowable intervals in order to be compliant. You will need to schedule your maintenance during available outages to complete your maintenance as required, even if it means that you may do protective relay maintenance more frequently than the maximum allowable intervals. The maintenance intervals were selected with typical plant outages, among other things, in mind.

If I am unable to complete the maintenance, as required, due to a major natural disaster (hurricane, earthquake, etc.), how will this affect my compliance with this standard?

The Sanction Guidelines of the North American Electric Reliability Corporation, effective January 15, 2008, provides that the Compliance Monitor will consider extenuating circumstances when considering any sanctions.

What if my observed testing results show a high incidence of out-of-tolerance relays; or, even worse, I am experiencing numerous relay Misoperations due to the relays being out-of-tolerance?

The established maximum time intervals are mandatory only as a not-to-exceed limitation. The establishment of a maximum is measurable. But any entity can choose to test some or all of their Protection System components more frequently (or to express it differently, exceed the minimum requirements of the standard). Particularly if you find that the maximum intervals in the standard do not achieve your expected level of performance, it is understandable that you would maintain the related equipment more frequently. A high incidence of relay Misoperations is in no one's best interest.

We believe that the four-month interval between inspections is unnecessary. Why can we not perform these inspections twice per year?

The Standard Drafting Team, through the comment process, has discovered that routine monthly inspections are not the norm. To align routine station inspections with other important inspections, the four-month interval was chosen. In lieu of station visits, many activities can be accomplished with automated monitoring and alarming.

Our maintenance plan calls for us to perform routine protective relay tests every 3 years. If we are unable to achieve this schedule, but we are able to complete the procedures in less than the maximum time interval, then are we in or out of compliance?

According to Requirement R3, if you have a time-based maintenance program, then you will be in violation of the standard only if you exceed the maximum maintenance intervals prescribed in the Tables. According to Requirement R4, if your device in question is part of a Performance-Based Maintenance program, then you will be in violation of the standard if you fail to meet your PSMP, even if you do not exceed the maximum maintenance intervals prescribed in the Tables. The intervals in the Tables are associated with TBM and CBM; Attachment A is associated with PBM.

Please provide a sample list of devices or systems that must be verified in a generator, generator step-up transformer, generator connected station service or generator connected excitation transformer to meet the requirements of this maintenance standard.

Examples of typical devices and systems that may directly trip the generator, or trip through a lockout relay, may include, but are not necessarily limited to:

- Fault protective functions, including distance functions, voltage-restrained overcurrent functions, or voltage-controlled overcurrent functions
- Loss-of-field relays
- Volts-per-hertz relays
- Negative sequence overcurrent relays
- Over voltage and under voltage protection relays
- Stator-ground relays
- Communications-based Protection Systems such as transfer-trip systems

-
- Generator differential relays
 - Reverse power relays
 - Frequency relays
 - Out-of-step relays
 - Inadvertent energization protection
 - Breaker failure protection

For generator step-up, generator-connected station service transformers, or generator connected excitation transformers, operation of any of the following associated protective relays frequently would result in a trip of the generating unit; and, as such, would be included in the program:

- Transformer differential relays
- Neutral overcurrent relay
- Phase overcurrent relays
- Sudden Pressure Relaying

Relays which trip breakers serving station auxiliary Loads such as pumps, fans, or fuel handling equipment, etc., need not be included in the program, even if the loss of the those Loads could result in a trip of the generating unit. Furthermore, relays which provide protection to secondary unit substation (SUS) or low switchgear transformers and relays protecting other downstream plant electrical distribution system components are not included in the scope of this program, even if a trip of these devices might eventually result in a trip of the generating unit. For example, a thermal overcurrent trip on the motor of a coal-conveyor belt could eventually lead to the tripping of the generator, but it does not cause the trip.

In the case where a plant does not have a generator connected station service transformer such that it is normally fed from a system connected station service transformer, is it still the drafting team's intent to exclude the Protection Systems for these system connected auxiliary transformers from scope even when the loss of the normal (system connected) station service transformer will result in a trip of a BES generating Facility?

The SDT does not intend that the system-connected station service transformers be included in the Applicability. The generator-connected station service transformers and generator connected excitation transformers are often connected to the generator bus directly without an interposing breaker; thus, the Protection Systems on these transformers will trip the generator as discussed in 4.2.5.1.

What is meant by "verify operation of the relay inputs and outputs that are essential to proper functioning of the Protection System?"

Any input or output (of the relay) that "affects the tripping" of the breaker is included in the scope of I/O of the relay to be verified. By "affects the tripping," one needs to realize that sometimes there are more inputs and outputs than simply the output to the trip coil. Many

important protective functions include things like breaker fail initiation, zone timer initiation and sometimes even 52a/b contact inputs are needed for a protective relay to correctly operate.

Each input should be “picked up” or “turned on and off” and verified as changing state by the microprocessor of the relay. Each output should be “operated” or “closed and opened” from the microprocessor of the relay and the output should be verified to change state on the output terminals of the relay. One possible method of testing inputs of these relays is to “jumper” the needed dc voltage to the input and verify that the relay registered the change of state.

Electromechanical lock-out relays (86) (used to convey the tripping current to the trip coils) need to be electrically operated to prove the capability of the device to change state. These tests need to be accomplished at least every six years, unless PBM methodology is applied.

The contacts on the 86 or auxiliary tripping relays (94) that change state to pass on the trip current to a breaker trip coil need only be checked every 12 years with the control circuitry.

What is the difference between a distributed UFLS/UVLS and a non-distributed UFLS/UVLS scheme?

A distributed UFLS or UVLS scheme contains individual relays which make independent Load shed decisions based on applied settings and localized voltage and/or current inputs. A distributed scheme may involve an enable/disable contact in the scheme and still be considered a distributed scheme. A non-distributed UFLS or UVLS scheme involves a system where there is some type of centralized measurement and Load shed decision being made. A non-distributed UFLS/UVLS scheme is considered similar to an RAS scheme and falls under Table 1 for maintenance activities and intervals.

8.2 Retention of Records

PRC-005-1 describes a reporting or auditing cycle of one year and retention of records for three years. However, with a three-year retention cycle, the records of verification for a Protection System might be discarded before the next verification, leaving no record of what was done if a Misoperation or failure is to be analyzed.

PRC-005-6 corrects this by requiring:

The Transmission Owner, Generator Owner, and Distribution Provider shall each keep data or evidence to show compliance as identified below unless directed by its Compliance Enforcement Authority to retain specific evidence for a longer period of time as part of an investigation.

For Requirement R1, the Transmission Owner, Generator Owner, and Distribution Provider shall each keep its current dated Protection System Maintenance Program, as well as any superseded versions since the preceding compliance audit, including the documentation that specifies the type of maintenance program applied for each Protection System, Automatic Reclosing, or Sudden Pressure Relaying Component Type.

For Requirement R2, Requirement R3, and Requirement R4, in cases where the interval of the maintenance activity is longer than the audit cycle, the Transmission Owner, Generator Owner, and Distribution Provider shall each keep documentation of the most recent performance of that maintenance activity for the Protection System, Automatic Reclosing, or Sudden Pressure Relaying Component. In cases where the interval of the maintenance activity is shorter than the audit cycle, documentation of all performances

(in accordance with the tables) of that maintenance activity for the Protection System, Automatic Reclosing, or Sudden Pressure Relaying Component since the previous scheduled audit date shall be retained.

For Requirement R5 the Transmission Owner, Generator Owner, and Distribution Provider shall each keep documentation of Unresolved Maintenance Issues identified by the entity since the last audit, including all that were resolved since the last audit.

This requirement assures that the documentation shows that the interval between maintenance cycles correctly meets the maintenance interval limits. The requirement is actually alerting the industry to documentation requirements already implemented by audit teams. Evidence of compliance bookending the interval shows interval accomplished instead of proving only your planned interval.

The SDT is aware that, in some cases, the retention period could be relatively long. But, the retention of documents simply helps to demonstrate compliance.

8.2.1 Frequently Asked Questions:

Please clarify the data retention requirements.

The data retention requirements are intended to allow the availability of maintenance records to demonstrate that the time intervals in your maintenance plan were upheld.

<u>Maximum Maintenance Interval</u>	<u>Data Retention Period</u>
4 Months, 6 Months, 18 Months, or 3 Years	All activities since previous audit
6 Years	All activities since previous audit (assuming a 6 year audit cycle) or most recent performance (assuming 3 year audit cycle), whichever is longer
12 Year	All activities from the most recent performance

If an entity prefers to utilize Performance-Based Maintenance, then statistical data may be retained for extended periods to assist with future adjustments in time intervals.

If an equipment item is replaced, then the entity can restart the maintenance-time-interval-clock if desired; however, the replacement of equipment does not remove any documentation requirements that would have been required to verify compliance with time-interval requirements. In other words, do not discard maintenance data that goes to verify your work.

The retention of documentation for new and/or replaced equipment is all about proving that the maintenance intervals had been in compliance. For example, a long-range plan of upgrades might lead an entity to ignore required maintenance; retaining the evidence of prior maintenance that existed before any retirements and upgrades proves compliance with the standard.

What does this Maintenance Standard say about commissioning? Is it necessary to have documentation in your maintenance history of the completion of commission testing?

This standard does not establish requirements for commission testing. Commission testing includes all testing activities necessary to conclude that a Facility has been built in accordance with design. While a thorough commission testing program would include, either directly or indirectly, the verification of all those Protection System attributes addressed by the maintenance activities specified in the Tables of PRC-005-6, verification of the adequacy of initial installation necessitates the performance of testing and inspections that go well beyond these routine maintenance activities. For example, commission testing might set baselines for future tests; perform acceptance tests and/or warranty tests; utilize testing methods that are not generally done routinely like staged-Fault-tests.

However, many of the Protection System attributes which are verified during commission testing are not subject to age related or service related degradation, and need not be re-verified within an ongoing maintenance program. Example--it is not necessary to re-verify correct terminal strip wiring on an ongoing basis.

PRC-005-6 assumes that thorough commission testing was performed prior to a Protection System being placed in service. PRC-005-6 requires performance of maintenance activities that are deemed necessary to detect and correct plausible age and service related degradation of components, such that a properly built and commission tested Protection System will continue to function as designed over its service life.

It should be noted that commission testing frequently is performed by a different organization than that which is responsible for the ongoing maintenance of the Protection System. Furthermore, the commission testing activities will not necessarily correlate directly with the maintenance activities required by the standard. As such, it is very likely that commission testing records will deviate significantly from maintenance records in both form and content; and, therefore, it is not necessary to maintain commission testing records within the maintenance program documentation.

Notwithstanding the differences in records, an entity would be wise to retain commissioning records to show a maintenance start date. (See below). An entity that requires that their commissioning tests have, at a minimum, the requirements of PRC-005-6 would help that entity prove time interval maximums by setting the initial time clock.

How do you determine the initial due date for maintenance?

The initial due date for maintenance should be based upon when a Protection System was tested. Alternatively, an entity may choose to use the date of completion of the commission testing of the Protection System component and the system was placed into service as the starting point in determining its first maintenance due dates. Whichever method is chosen, for newly installed Protection Systems the components should not be placed into service until minimum maintenance activities have taken place.

It is conceivable that there can be a (substantial) difference in time between the date of testing, as compared to the date placed into service. The use of the "Calendar Year" language can help determine the next due date without too much concern about being non-compliant for missing test dates by a small amount (provided your dates are not already at the end of a year). However, if there is a substantial amount of time difference between testing and in-service dates, then the

testing date should be followed because it is the degradation of components that is the concern. While accuracy fluctuations may decrease when components are not energized, there are cases when degradation can take place, even though the device is not energized. Minimizing the time between commissioning tests and in-service dates will help.

If I miss two battery inspections four times out of 100 Protection System components on my transmission system, does that count as 2% or 8% when counting Violation Severity Level (VSL) for R3?

The entity failed to complete its scheduled program on two of its 100 Protection System components, which would equate to 2% for application to the VSL Table for Requirement R3. This VSL is written to compare missed components to total components. In this case two components out of 100 were missed, or 2%.

How do I achieve a “grace period” without being out of compliance?

The objective here is to create a time extension within your own PSMP that still does not violate the maximum time intervals stated in the standard. Remember that the maximum time intervals listed in the Tables cannot be extended.

For the purposes of this example, concentrating on just unmonitored protective relays – Table 1-1 specifies a maximum time interval (between the mandated maintenance activities) of six calendar years. Your plan must ensure that your unmonitored relays are tested at least once every six calendar years. You could, within your PSMP, require that your unmonitored relays be tested every four calendar years, with a maximum allowable time extension of 18 calendar months. This allows an entity to have deadlines set for the auto-generation of work orders, but still has the flexibility in scheduling complex work schedules. This also allows for that 18 calendar months to act as a buffer, in effect a grace period within your PSMP, in the event of unforeseen events. You will note that this example of a maintenance plan interval has a planned time of four years; it also has a built-in time extension allowed within the PSMP, and yet does not exceed the maximum time interval allowed by the standard. So while there are no time extensions allowed beyond the standard, an entity can still have substantial flexibility to maintain their Protection System components.

8.3 Basis for Table 1 Intervals

When developing the original *Protection System Maintenance – A Technical Reference* in 2007, the SPCTF collected all available data from Regional Entities (REs) on time intervals recommended for maintenance and test programs. The recommendations vary widely in categorization of relays, defined maintenance actions, and time intervals, precluding development of intervals by averaging. The SPCTF also reviewed the 2005 Report [2] of the IEEE Power System Relaying Committee Working Group I-17 (Transmission Relay System Performance Comparison). Review of the I-17 report shows data from a small number of utilities, with no company identification or means of investigating the significance of particular results.

To develop a solid current base of practice, the SPCTF surveyed its members regarding their maintenance intervals for electromechanical and microprocessor relays, and asked the members to also provide definitively-known data for other entities. The survey represented 470 GW of peak Load, or 4% of the NERC peak Load. Maintenance interval averages were compiled by weighting reported intervals according to the size (based on peak Load) of the reporting

utility. Thus, the averages more accurately represent practices for the large populations of Protection Systems used across the NERC regions.

The results of this survey with weighted averaging indicate maintenance intervals of five years for electromechanical or solid state relays, and seven years for unmonitored microprocessor relays.

A number of applicable entities have extended maintenance intervals for microprocessor relays beyond seven years, based on favorable experience with the particular products they have installed. To provide a technical basis for such extension, the SPCTF authors developed a recommendation of 10 years using the Markov modeling approach from [1], as summarized in Section 8.4. The results of this modeling depend on the completeness of self-testing or monitoring. Accordingly, this extended interval is allowed by Table 1, only when such relays are monitored as specified in the attributes of monitoring contained in Tables 1-1 through 1-5 and Table 2. Monitoring is capable of reporting Protection System health issues that are likely to affect performance within the 10 year time interval between verifications.

It is important to note that, according to modeling results, Protection System availability barely changes as the maintenance interval is varied below the 10-year mark. Thus, reducing the maintenance interval does not improve Protection System availability. With the assumptions of the model regarding how maintenance is carried out, reducing the maintenance interval actually degrades Protection System availability.

8.4 Basis for Extended Maintenance Intervals for Microprocessor Relays

Table 1 allows maximum verification intervals that are extended based on monitoring level. The industry has experience with self-monitoring microprocessor relays that leads to the Table 1 value for a monitored relay, as explained in Section 8.3. To develop a basis for the maximum interval for monitored relays in their *Protection System Maintenance – A Technical Reference*, the SPCTF used the methodology of Reference [1], which specifically addresses optimum routine maintenance intervals. The Markov modeling approach of [1] is judged to be valid for the design and typical failure modes of microprocessor relays.

The SPCTF authors ran test cases of the Markov model to calculate two key probability measures:

- Relay Unavailability - the probability that the relay is out of service due to failure or maintenance activity while the power system Element to be protected is in service.
- Abnormal Unavailability - the probability that the relay is out of service due to failure or maintenance activity when a Fault occurs, leading to failure to operate for the Fault.

The parameter in the Markov model that defines self-monitoring capability is ST (for self-test). ST = 0 if there is no self-monitoring; ST = 1 for full monitoring. Practical ST values are estimated to range from .75 to .95. The SPCTF simulation runs used constants in the Markov model that were the same as those used in [1] with the following exceptions:

Sn, Normal tripping operations per hour = 21600 (reciprocal of normal Fault clearing time of 10 cycles)

Sb, Backup tripping operations per hour = 4320 (reciprocal of backup Fault clearing time of 50 cycles)

Rc, Protected component repairs per hour = 0.125 (8 hours to restore the power system)

Rt, Relay routine tests per hour = 0.125 (8 hours to test a Protection System)

Rr, Relay repairs per hour = 0.08333 (12 hours to complete a Protection System repair after failure)

Experimental runs of the model showed low sensitivity of optimum maintenance interval to these parameter adjustments.

The resulting curves for relay unavailability and abnormal unavailability versus maintenance interval showed a broad minimum (optimum maintenance interval) in the vicinity of 10 years – the curve is flat, with no significant change in either unavailability value over the range of 9, 10, or 11 years. This was true even for a relay mean time between Failures (MTBF) of 50 years, much lower than MTBF values typically published for these relays. Also, the Markov modeling indicates that both the relay unavailability and abnormal unavailability actually become higher with more frequent testing. This shows that the time spent on these more frequent tests yields no failure discoveries that approach the negative impact of removing the relays from service and running the tests.

The PSMT SDT discussed the practical need for “time-interval extensions” or “grace periods” to allow for scheduling problems that resulted from any number of business contingencies. The time interval discussions also focused on the need to reflect industry norms surrounding Generator outage frequencies. Finally, it was again noted that FERC Order 693 demanded maximum time intervals. “Maximum time intervals” by their very term negates any “time-interval extension” or “grace periods.” To recognize the need to follow industry norms on Generator outage frequencies and accommodate a form of time-interval extension, while still following FERC Order 693, the Standard Drafting Team arrived at a six-year interval for the electromechanical relay, instead of the five-year interval arrived at by the SPCTF. The PSMT SDT has followed the FERC directive for a *maximum* time interval and has determined that no extensions will be allowed. Six years has been set for the maximum time interval between manual maintenance activities. This maximum time interval also works well for maintenance cycles that have been in use in generator plants for decades.

For monitored relays, the PSMT SDT notes that the SPCTF called for 10 years as the interval between maintenance activities. This 10-year interval was chosen, even though there was “...no significant change in unavailability value over the range of 9, 10, or 11 years. This was true even for a relay Mean Time between Failures (MTBF) of 50 years...” The Standard Drafting Team again sought to align maintenance activities with known successful practices and outage schedules. The Standard does not allow extensions on any component of the Protection System; thus, the maximum allowed interval for these components has been set to 12 years. Twelve years also fits well into the traditional maintenance cycles of both substations and generator plants.

Also of note is the Table’s use of the term “Calendar” in the column for “Maximum Maintenance Interval.” The PSMT SDT deemed it necessary to include the term “Calendar” to facilitate annual maintenance planning, scheduling and implementation. This need is the result of known occurrences of system requirements that could cause maintenance schedules to be missed by a few days or weeks. The PSMT SDT chose the term “Calendar” to preclude the need to have schedules be met to the day. An electromechanical protective relay that is maintained in year number one need not be revisited until six years later (year number seven). For example, a relay

was maintained April 10, 2008; maintenance would need to be completed no later than December 31, 2014.

Though not a requirement of this standard, to stay in line with many Compliance Enforcement Agencies audit processes an entity should define, within their own PSMP, the entity's use of terms like annual, calendar year, etc. Then, once this is within the PSMP, the entity should abide by their chosen language.

9. Performance-Based Maintenance Process

In lieu of using the Table 1 intervals, a Performance-Based Maintenance process may be used to establish maintenance intervals (*PRC-005 Attachment A Criteria for a Performance-Based Protection System Maintenance Program*). A Performance-Based Maintenance process may justify longer maintenance intervals, or require shorter intervals relative to Table 1. In order to use a Performance-Based Maintenance process, the documented maintenance program must include records of repairs, adjustments, and corrections to covered Protection Systems in order to provide historical justification for intervals, other than those established in Table 1. Furthermore, the asset owner must regularly analyze these records of corrective actions to develop a ranking of causes. Recurrent problems are to be highlighted, and remedial action plans are to be documented to mitigate or eliminate recurrent problems.

Entities with Performance-Based Maintenance track performance of Protection Systems, demonstrate how they analyze findings of performance failures and aberrations, and implement continuous improvement actions. Since no maintenance program can ever guarantee that no malfunction can possibly occur, documentation of a Performance-Based Maintenance program would serve the utility well in explaining to regulators and the public a Misoperation leading to a major System outage event.

A Performance-Based Maintenance program requires auditing processes like those included in widely used industrial quality systems (such as *ISO 9001-2000, Quality Management Systems – Requirements*; or applicable parts of the NIST Baldrige National Quality Program). The audits periodically evaluate:

- The completeness of the documented maintenance process
- Organizational knowledge of and adherence to the process
- Performance metrics and documentation of results
- Remediation of issues
- Demonstration of continuous improvement.

In order to opt into a Performance-Based Maintenance (PBM) program, the asset owner must first sort the various Components into population segments. Any population segment must be comprised of at least 60 individual units; if any asset owner opts for PBM, but does not own 60 units to comprise a population, then that asset owner may combine data from other asset owners until the needed 60 units is aggregated. Each population segment must be composed of a grouping of Components of a consistent design standard or particular model or type from a single manufacturer and subjected to similar environmental factors. For example: One segment cannot be comprised of both GE & Westinghouse electro-mechanical lock-out relays; likewise, one segment cannot be comprised of 60 GE lock-out relays, 30 of which are in a dirty environment, and the remaining 30 from a clean environment. This PBM process cannot be applied to batteries, but can be applied to all other Components, including (but not limited to) specific battery chargers, instrument transformers, trip coils and/or control circuitry (etc.).

9.1 Minimum Sample Size

Large Sample Size

An assumption that needs to be made when choosing a sample size is “the sampling distribution of the sample mean can be approximated by a normal probability distribution.” The Central Limit Theorem states: “In selecting simple random samples of size n from a population, the sampling distribution of the sample mean \bar{x} can be approximated by a normal probability distribution as the sample size becomes large.” (Essentials of Statistics for Business and Economics, Anderson, Sweeney, Williams, 2003.)

To use the Central Limit Theorem in statistics, the population size should be large. The references below are supplied to help define what is large.

“... whenever we are using a large simple random sample (rule of thumb: $n \geq 30$), the central limit theorem enables us to conclude that the sampling distribution of the sample mean can be approximated by a normal distribution.” (Essentials of Statistics for Business and Economics, Anderson, Sweeney, Williams, 2003.)

“If samples of size n , when $n \geq 30$, are drawn from any population with a mean μ and a standard deviation σ , the sampling distribution of sample means approximates a normal distribution. The greater the sample size, the better the approximation.” (Elementary Statistics - Picturing the World, Larson, Farber, 2003.)

“The sample size is large (generally $n \geq 30$)... (Introduction to Statistics and Data Analysis - Second Edition, Peck, Olson, Devore, 2005.)

“... the normal is often used as an approximation to the t distribution in a test of a null hypothesis about the mean of a normally distributed population when the population variance is estimated from a relatively large sample. A sample size exceeding 30 is often given as a minimal size in this connection.” (Statistical Analysis for Business Decisions, Peters, Summers, 1968.)

Error of Distribution Formula

Beyond the large sample size discussion above, a sample size requirement can be estimated using the bound on the Error of Distribution Formula when the expected result is of a “Pass/Fail” format and will be between 0 and 1.0.

The Error of Distribution Formula is:

$$B = z \sqrt{\frac{\pi(1-\pi)}{n}}$$

Where:

B = bound on the error of distribution (allowable error)

z = standard error

π = expected failure rate

n = sample size required

Solving for n provides:

$$n = \pi(1 - \pi) \left(\frac{z}{B} \right)^2$$

Minimum Population Size to use Performance-Based Program

One entity's population of components should be large enough to represent a sizeable sample of a vendor's overall population of manufactured devices. For this reason, the following assumptions are made:

$$B = 5\%$$

$$z = 1.96 \text{ (This equates to a 95\% confidence level)}$$

$$\pi = 4\%$$

Using the equation above, $n=59.0$.

Minimum Sample Size to evaluate Performance-Based Program

The number of components that should be included in a sample size for evaluation of the appropriate testing interval can be smaller because a lower confidence level is acceptable since the sample testing is repeated or updated annually. For this reason, the following assumptions are made:

$$B = 5\%$$

$$z = 1.44 \text{ (85\% confidence level)}$$

$$\pi = 4\%$$

Using the equation above, $n=31.8$.

Recommendation

Based on the above discussion, a sample size should be at least 30 to allow use of the equation mentioned. Using this and the results of the equation, the following numbers are recommended (and required within the standard):

Minimum Population Size to use Performance-Based Maintenance Program = 60

Minimum Sample Size to evaluate Performance-Based Program = 30.

Once the population segment is defined, then maintenance must begin within the intervals as outlined for the device described in the Tables 1-1 through 1-5. Time intervals can be lengthened provided the last years' worth of components tested (or the last 30 units maintained, whichever is more) had fewer than 4% Countable Events. It is notable that 4% is specifically chosen because an entity with a small population (30 units) would have to adjust its time intervals between maintenance if more than one Countable Event was found to have occurred during the last analysis period. A smaller percentage would require that entity to adjust the time interval between maintenance activities if even one unit is found out of tolerance or causes a Misoperation.

The minimum number of units that can be tested in any given year is 5% of the population. Note that this 5% threshold sets a practical limitation on total length of time between intervals at 20 years.

If at any time the number of Countable Events equals or exceeds 4% of the last year's tested components (or the last 30 units maintained, whichever is more), then the time period between manual maintenance activities must be decreased. There is a time limit on reaching the decreased time at which the Countable Events is less than 4%; this must be attained within three years.

Performance-Based Program Evaluation Example

The 4% performance target was derived as a protection system performance target and was selected based on the drafting team's experience and studies performed by several utilities. This is not derived from the performance of discrete devices. Microprocessor relays and electromechanical relays have different performance levels. It is not appropriate to compare these performance levels to each other. The performance of the segment should be compared to the 4% performance criteria.

In consideration of the use of Performance Based Maintenance (PBM), the user should consider the effects of extended testing intervals and the established 4% failure rate. In the table shown below, the segment is 1000 units. As the testing interval (in years) increases, the number of units tested each year decreases. The number of countable events allowed is 4% of the tested units. Countable events are the failure of a Component requiring repair or replacement, any corrective actions performed during the maintenance test on the units within the testing segment (units per year), or any Misoperation attributable to hardware failure or calibration failure found within the entire segment (1000 units) during the testing year.

Example: 1000 units in the segment with a testing interval of 8 years: The number of units tested each year will be 125 units. The total allowable countable events equals: $125 \times .04 = 5$. This number includes failure of a Component requiring repair or replacement, corrective issues found during testing, and the total number of Misoperations (attributable to hardware or calibration failure within the testing year) associated with the entire segment of 1000 units.

Example: 1000 units in the segment with a testing interval of 16 years: The number of units tested each year will be 63 units. The total allowable countable events equals: $63 \times .04 = 2.5$.

As shown in the above examples, doubling the testing interval reduces the number of allowable events by half.

Total number of units in the segment	1000
Failure rate	4.00%

Testing Intervals (Years)	Units Per Year	Acceptable Number of Countable Events per year	Yearly Failure Rate Based on 1000 Units in Segment
1	1000.00	40.00	4.00%
2	500.00	20.00	2.00%
4	250.00	10.00	1.00%
6	166.67	6.67	0.67%
8	125.00	5.00	0.50%
10	100.00	4.00	0.40%
12	83.33	3.33	0.33%
14	71.43	2.86	0.29%
16	62.50	2.50	0.25%
18	55.56	2.22	0.22%
20	50.00	2.00	0.20%

Using the prior year’s data, determine the maximum allowable maintenance interval for each Segment such that the Segment experiences Countable Events on no more than 4% of the Components within the Segment, for the greater of either the last 30 Components maintained or all Components maintained in the previous year.

Segment – Components of a consistent design standard, or a particular model or type from a single manufacturer that typically share other common elements. Consistent performance is expected across the entire population of a Segment. A Segment must contain at least sixty (60) individual Components.

Countable Event – A failure of a Component requiring repair or replacement, any condition discovered during the maintenance activities in Tables 1-1 through 1-5, Table 3, Table 4-1 through Table 4-3, and Table 5, which requires corrective action or a Protection System Misoperation attributed to hardware failure or calibration failure. Misoperations due to product design errors, software errors, relay settings different from specified settings, Protection System Component, Automatic Reclosing, or Sudden Pressure Relaying configuration or application errors are not included in Countable Events.

9.2 Frequently Asked Questions:

I’m a small entity and cannot aggregate a population of Protection System components to establish a segment required for a Performance-Based Protection System Maintenance Program. How can I utilize that opportunity?

Multiple asset owning entities may aggregate their individually owned populations of individual Protection System components to create a segment that crosses ownership boundaries. All entities participating in a joint program should have a single documented joint management process, with consistent Protection System Maintenance Programs (practices, maintenance intervals and criteria), for which the multiple owners are individually responsible with respect to the requirements of the Standard. The requirements established for Performance-Based Maintenance must be met for the overall aggregated program on an ongoing basis.

The aggregated population should reflect all factors that affect consistent performance across the population, including any relevant environmental factors such as geography, power-plant vs. substation, and weather conditions.

Can an owner go straight to a Performance-Based Maintenance program schedule, if they have previously gathered records?

Yes--an owner can go to a Performance-Based Maintenance program immediately. The owner will need to comply with the requirements of a Performance-Based Maintenance program as listed in the Standard. Gaps in the data collected will not be allowed; therefore, if an owner finds that a gap exists such that they cannot prove that they have collected the data as required for a Performance-Based Maintenance program then they will need to wait until they can prove compliance.

When establishing a Performance-Based Maintenance program, can I use test data from the device manufacturer, or industry survey results, as results to help establish a basis for my Performance-Based intervals?

No--you must use actual in-service test data for the components in the segment.

What types of Misoperations or events are not considered Countable Events in the Performance-Based Protection System Maintenance (PBM) Program?

Countable Events are intended to address conditions that are attributed to hardware failure or calibration failure; that is, conditions that reflect deteriorating performance of the component. These conditions include any condition where the device previously worked properly, then, due to changes within the device, malfunctioned or degraded to the point that re-calibration (to within the entity's tolerance) was required.

For this purpose of tracking hardware issues, human errors resulting in Protection System Misoperations during system installation or maintenance activities are not considered Countable Events. Examples of excluded human errors include relay setting errors, design errors, wiring errors, inadvertent tripping of devices during testing or installation, and misapplication of Protection System components. Examples of misapplication of Protection System components include wrong CT or PT tap position, protective relay function misapplication, and components not specified correctly for their installation. Obviously, if one is setting up relevant data about hardware failures then human failures should be eliminated from the hardware performance analysis.

One example of human-error is not pertinent data might be in the area of testing "86" lock-out relays (LOR). "Entity A" has two types of LOR's type "X" and type "Y"; they want to move into a performance based maintenance interval. They have 1000 of each type, so the population variables are met. During electrical trip testing of all of their various schemes over the initial six-year interval they find zero type "X" failures, but human error led to tripping a BES Element 100 times; they find 100 type "Y" failures and had an additional 100 human-error caused tripping incidents. In this example the human-error caused Misoperations should not be used to judge the performance of either type of LOR. Analysis of the data might lead "Entity A" to change time intervals. Type "X" LOR can be placed into extended time interval testing because of its low failure rate (zero failures) while Type "Y" would have to be tested more often than every 6 calendar years (100 failures divided by 1000 units exceeds the 4% tolerance level).

Certain types of Protection System component errors that cause Misoperations are not considered Countable Events. Examples of excluded component errors include device malfunctions that are correctable by firmware upgrades and design errors that do not impact protection function.

What are some examples of methods of correcting segment performance for Performance-Based Maintenance?

There are a number of methods that may be useful for correcting segment performance for mal-performing segments in a Performance-Based Maintenance system. Some examples are listed below.

- The maximum allowable interval, as established by the Performance-Based Maintenance system, can be decreased. This may, however, be slow to correct the performance of the segment.
- Identifiable sub-groups of components within the established segment, which have been identified to be the mal-performing portion of the segment, can be broken out as an independent segment for target action. Each resulting segment must satisfy the minimum population requirements for a Performance-Based Maintenance program in order to remain within the program.
- Targeted corrective actions can be taken to correct frequently occurring problems. An example would be replacement of capacitors within electromechanical distance relays if bad capacitors were determined to be the cause of the mal-performance.
- Components within the mal-performing segment can be replaced with other components (electromechanical distance relays with microprocessor relays, for example) to remove the mal-performing segment.

If I find (and correct) a Unresolved Maintenance Issue as a result of a Misoperation investigation (Re: PRC-004), how does this affect my Performance-Based Maintenance program?

If you perform maintenance on a Protection System component for any reason (including as part of a PRC-004 required Misoperation investigation/corrective action), the actions performed can count as a maintenance activity provided the activities in the relevant Tables have been done, and, if you desire, “reset the clock” on everything you’ve done. In a Performance-Based Maintenance program, you also need to record the Unresolved Maintenance Issue as a Countable Event within the relevant component group segment and use it in the analysis to determine your correct Performance-Based Maintenance interval for that component group. Note that “resetting the clock” should not be construed as interfering with an entity’s routine testing schedule because the “clock-reset” would actually make for a decreased time interval by the time the next routine test schedule comes around.

For example, a relay scheme, consisting of four relays, is tested on 1-1-11 and the PSMP has a time interval of 3 calendar years with an allowable extension of 1 calendar year. The relay would be due again for routine testing before the end of the year 2015. This hypothetical relay scheme has a Misoperation on 6-1-12 that points to one of the four relays as bad. Investigation proves a bad relay and a new one is tested and installed in place of the original. This replacement relay actually could be retested before the end of the year 2016 (clock-reset) and not be out of

compliance. This requires tracking maintenance by individual relays and is allowed. However, many companies schedule maintenance in other ways like by substation or by circuit breaker or by relay scheme. By these methods of tracking maintenance that “replaced relay” will be retested before the end of the year 2015. This is also acceptable. In no case was a particular relay tested beyond the PSMP of four years max, nor was the 6 year max of the Standard exceeded. The entity can reset the clock if they desire or the entity can continue with original schedules and, in effect, test even more frequently.

Why are batteries excluded from PBM? What about exclusion of batteries from condition based maintenance?

Batteries are the only element of a Protection System that is a perishable item with a shelf life. As a perishable item batteries require not only a constant float charge to maintain their freshness (charge), but periodic inspection to determine if there are problems associated with their aging process and testing to see if they are maintaining a charge or can still deliver their rated output as required.

Besides being perishable, a second unique feature of a battery that is unlike any other Protection System element, is that a battery uses chemicals, metal alloys, plastics, welds, and bonds that must interact with each other to produce the constant dc source required for Protection Systems, undisturbed by ac system Disturbances.

No type of battery manufactured today for Protection System application is free from problems of the sort that can only be detected over time by inspection and test. These problems can arise from variances in the manufacturing process, chemicals and alloys used in the construction of the individual cells, quality of welds and bonds to connect the components, the plastics used to make batteries, and the cell forming process for the individual battery cells.

Other problems that require periodic inspection and testing can result from transportation from the factory to the job site, length of time before a charge is put on the battery, the method of installation, the voltage level and duration of equalize charges, the float voltage level used, and the environment that the battery is installed in.

All of the above mentioned factors, as well as several more not discussed here, are beyond the control of the Functional Entities that want to use a Performance-Based Protection System Maintenance (PBM) program. Inherent variances in the aging process of a battery cell make establishment of a designated segment based on manufacturer and type of battery impossible.

The whole point of PBM is that if all variables are isolated then common aging and performance criteria would be the same. However, there are too many variables in the electrochemical process to completely isolate all of the performance-changing criteria.

Similarly, Functional Entities that want to establish a condition-based maintenance program using the highest levels of monitoring, resulting in the least amount of hands-on maintenance activity, cannot completely eliminate some periodic maintenance of the battery used in a station dc supply. Inspection of the battery is required on a Maximum Maintenance Interval listed in the tables due to the aging processes of station batteries. However, higher degrees of monitoring of a battery can eliminate the requirement for some periodic testing and some inspections (see Table 1-4).

Please provide an example of the calculations involved in extending maintenance time intervals using PBM.

Entity has 1000 GE-HEA lock-out relays; this is greater than the minimum sample requirement of 60. They start out testing all of the relays within the prescribed Table requirements (6 year max) by testing the relays every 5 years. The entity's plan is to test 200 units per year; this is greater than the minimum sample size requirement of 30. For the sake of example only the following will show 6 failures per year, reality may well have different numbers of failures every year. PBM requires annual assessment of failures found per units tested. After the first year of tests the entity finds 6 failures in the 200 units tested. $6/200 = 3\%$ failure rate. This entity is now allowed to extend the maintenance interval if they choose. The entity chooses to extend the maintenance interval of this population segment out to 10 years. This represents a rate of 100 units tested per year; entity selects 100 units to be tested in the following year. After that year of testing these 100 units the entity again finds 6 failed units. $6/100 = 6\%$ failures. This entity has now exceeded the acceptable failure rate for these devices and must accelerate testing of all of the units at a higher rate such that the failure rate is found to be less than 4% per year; the entity has three years to get this failure rate down to 4% or less (per year). In response to the 6% failure rate, the entity decreases the testing interval to 8 years. This means that they will now test 125 units per year ($1000/8$). The entity has just two years left to get the test rate corrected.

After a year, they again find six failures out of the 125 units tested. $6/125 = 5\%$ failures. In response to the 5% failure rate, the entity decreases the testing interval to seven years. This means that they will now test 143 units per year ($1000/7$). The entity has just one year left to get the test rate corrected. After a year, they again find six failures out of the 143 units tested. $6/143 = 4.2\%$ failures.

(Note that the entity has tried five years and they were under the 4% limit and they tried seven years and they were over the 4% limit. They must be back at 4% failures or less in the next year so they might simply elect to go back to five years.)

Instead, in response to the 5% failure rate, the entity decreases the testing interval to six years. This means that they will now test 167 units per year ($1000/6$). After a year, they again find six failures out of the 167 units tested. $6/167 = 3.6\%$ failures. Entity found that they could maintain the failure rate at no more than 4% failures by maintaining the testing interval at six years or less. Entity chose six-year interval and effectively extended their TBM (five years) program by 20%.

A note of practicality is that an entity will probably be in better shape to lengthen the intervals between tests if the failure rate is less than 2%. But the requirements allow for annual adjustments, if the entity desires. As a matter of maintenance management, an ever-changing test rate (units tested/year) may be un-workable.

Note that the "5% of components" requirement effectively sets a practical limit of 20 year maximum PBM interval. Also of note is the "3 years" requirement; an entity might arbitrarily extend time intervals from six years to 20 years. In the event that an entity finds a failure rate greater than 4%, then the test rate must be accelerated such that within three years the failure rate must be brought back down to 4% or less.

Here is a table that demonstrates the values discussed:

Year #	Total Population (P)	Test Interval (I)	Units to be Tested (U= P/I)	# of Failures Found (F)	Failure Rate (=F/U)	Decision to Change Interval Yes or No	Interval Chosen
1	1000	5 yrs	200	6	3%	Yes	10 yrs
2	1000	10 yrs	100	6	6%	Yes	8 yrs
3	1000	8 yrs	125	6	5%	Yes	7 yrs
4	1000	7 yrs	143	6	4.2%	Yes	6 yrs
5	1000	6 yrs	167	6	3.6%	No	6 yrs

Please provide an example of the calculations involved in extending maintenance time intervals using PBM for control circuitry.

Note that the following example captures “Control Circuitry” as all of the trip paths associated with a particular trip coil of a circuit breaker. An entity is not restricted to this method of counting control circuits. Perhaps another method an entity would prefer would be to simply track every individual (parallel) trip path. Or perhaps another method would be to track all of the trip outputs from a specific (set) of relays protecting a specific element.

The designation of what constitutes a control circuit component is very dependent upon how an entity performs and tracks the testing of the control circuitry. Some entities test their control circuits on a breaker basis whereas others test their circuitry on a local zone of protection basis. Thus, entities are allowed the latitude to designate their own definitions of control circuit components. Another example of where the entity has some discretion on determining what constitutes a single component is the voltage and current sensing devices, where the entity may choose either to designate a full three-phase set of such devices or a single device as a single component.

In Attachment A (PBM) the definition of Segment is:

Segment –*Components of a consistent design standard, or a particular model or type from a single manufacturer that typically share other common elements. Consistent performance is expected across the entire population of a segment. A segment must contain at least sixty (60) individual components.*

Example:

Entity has 1,000 circuit breakers, all of which have two trip coils, for a total of 2,000 trip coils; if all circuitry was designed and built with a consistent (internal entity) standard, then this is greater than the minimum sample requirement of 60.

For the sake of further example, the following facts are given:

Half of all relay panels (500) were built 40 years ago by an outside contractor, consisted of asbestos wrapped 600V-insulation panel wiring, and the cables exiting the control house are THHN pulled in conduit direct to exactly half of all of the various circuit breakers. All of the relay panels and cable pulls were built with consistent standards and consistent performance standard

expectations within the segment (which is greater than 60). Each relay panel has redundant microprocessor (MPC) relays (retrofitted); each MPC relay supplies an individual trip output to each of the two trip coils of the assigned circuit breaker.

Approximately 35 years ago, the entity developed their own internal construction crew and now builds all of their own relay panels from parts supplied from vendors that meet the entity's specifications, including SIS 600V insulation wiring and copper-sheathed cabling within the direct conduits to circuit breakers. The construction crew uses consistent standards in the construction. This newer segment of their control circuitry population is different than the original segment, consistent (standards, construction and performance expectations) within the new segment and constitutes the remainder of the entity's population (another 500 panels and the cabling to the remaining 500 circuit breakers). Each relay panel has redundant microprocessor (MPC) relays; each MPC relay supplies an individual trip output to each of the two trip coils of the assigned circuit breaker. Every trip path in this newer segment has a device that monitors the voltage directly across the trip contacts of the MPC relays and alarms via RTU and SCADA to the operations control room. This monitoring device, when not in alarm, demonstrates continuity all the way through the trip coil, cabling and wiring back to the trip contacts of the MPC relay.

The entity is tracking 2,000 trip coils (each consisting of multiple trip paths) in each of these two segments. But half of all of the trip paths are monitored; therefore, the trip paths are continuously tested and the circuit will alarm when there is a failure. These alarms have to be verified every 12 years for correct operation.

The entity now has 1,000 trip coils (and associated trip paths) remaining that they have elected to count as control circuits. The entity has instituted a process that requires the verification of every trip path to each trip coil (one unit), including the electrical activation of the trip coil. (The entity notes that the trip coils will have to be tripped electrically more often than the trip path verification, and is taking care of this activity through other documentation of Real-time Fault operations.)

They start out testing all of the trip coil circuits within the prescribed Table requirements (12-year max) by testing the trip circuits every 10 years. The entity's plan is to test 100 units per year; this is greater than the minimum sample size requirement of 30. For the sake of example only, the following will show three failures per year; reality may well have different numbers of failures every year. PBM requires annual assessment of failures found per units tested. After the first year of tests, the entity finds three failures in the 100 units tested. $3/100 = 3\%$ failure rate.

This entity is now allowed to extend the maintenance interval, if they choose. The entity chooses to extend the maintenance interval of this population segment out to 20 years. This represents a rate of 50 units tested per year; entity selects 50 units to be tested in the following year. After that year of testing these 50 units, the entity again finds three failed units. $3/50 = 6\%$ failures.

This entity has now exceeded the acceptable failure rate for these devices and must accelerate testing of all of the units at a higher rate, such that the failure rate is found to be less than 4% per year; the entity has three years to get this failure rate down to 4% or less (per year).

In response to the 6% failure rate, the entity decreases the testing interval to 16 years. This means that they will now test 63 units per year ($1000/16$). The entity has just two years left to get the

test rate corrected. After a year, they again find three failures out of the 63 units tested. $3/63 = 4.76\%$ failures.

In response to the $>4\%$ failure rate, the entity decreases the testing interval to 14 years. This means that they will now test 72 units per year ($1000/14$). The entity has just one year left to get the test rate corrected. After a year, they again find three failures out of the 72 units tested. $3/72 = 4.2\%$ failures.

(Note that the entity has tried 10 years, and they were under the 4% limit; and they tried 14 years, and they were over the 4% limit. They must be back at 4% failures or less in the next year, so they might simply elect to go back to 10 years.)

Instead, in response to the 4.2% failure rate, the entity decreases the testing interval to 12 years. This means that they will now test 84 units per year ($1000/12$). After a year, they again find three failures out of the 84 units tested. $3/84 = 3.6\%$ failures.

Entity found that they could maintain the failure rate at no more than 4% failures by maintaining the testing interval at 12 years or less. Entity chose 12-year interval, and effectively extended their TBM (10 years) program by 20%.

A note of practicality is that an entity will probably be in better shape to lengthen the intervals between tests if the failure rate is less than 2%. But the requirements allow for annual adjustments if the entity desires. As a matter of maintenance management, an ever-changing test rate (units tested / year) may be un-workable.

Note that the “5% of components” requirement effectively sets a practical limit of 20-year maximum PBM interval. Also of note is the “3 years” requirement; an entity might arbitrarily extend time intervals from six years to 20 years. In the event that an entity finds a failure rate greater than 4%, then the test rate must be accelerated such that within three years the failure rate must be brought back down to 4% or less.

Here is a table that demonstrates the values discussed:

Year #	Total Population (P)	Test Interval (I)	Units to be Tested (U= P/I)	# of Failures Found (F)	Failure Rate (=F/U)	Decision to Change Interval Yes or No	Interval Chosen
1	1000	10 yrs	100	3	3%	Yes	20 yrs
2	1000	20 yrs	50	3	6%	Yes	16yrs
3	1000	16 yrs	63	3	4.8%	Yes	14 yrs
4	1000	14 yrs	72	3	4.2%	Yes	12 yrs
5	1000	12 yrs	84	3	3.6%	No	12 yrs

Please provide an example of the calculations involved in extending maintenance time intervals using PBM for voltage and current sensing devices.

Note that the following example captures “voltage and current inputs to the protective relays” as all of the various current transformer and potential transformer signals associated with a particular set of relays used for protection of a specific Element. This entity calls this set of protective relays a “Relay Scheme.” Thus, this entity chooses to count PT and CT signals as a group instead of individually tracking maintenance activities to specific bushing CT’s or specific PT’s. An entity is not restricted to this method of counting voltage and current devices, signals and paths. Perhaps another method an entity would prefer would be to simply track every individual PT and CT. Note that a generation maintenance group may well select the latter because they may elect to perform routine off-line tests during generator outages, whereas a transmission maintenance group might create a process that utilizes Real-time system values measured at the relays.

The designation of what constitutes a control circuit component is very dependent upon how an entity performs and tracks the testing of the control circuitry. Some entities test their control circuits on a breaker basis whereas others test their circuitry on a local zone of protection basis. Thus, entities are allowed the latitude to designate their own definitions of control circuit components. Another example of where the entity has some discretion on determining what constitutes a single component is the voltage and current sensing devices, where the entity may choose either to designate a full three-phase set of such devices or a single device as a single component.

And in Attachment A (PBM) the definition of Segment:

Segment –*Components of a consistent design standard, or a particular model or type from a single manufacturer that typically share other common elements. Consistent performance is expected across the entire population of a segment. A segment must contain at least sixty (60) individual components.*

Example:

Entity has 2000 “Relay Schemes,” all of which have three current signals supplied from bushing CTs, and three voltage signals supplied from substation bus PT’s. All cabling and circuitry was designed and built with a consistent (internal entity) standard, and this population is greater than the minimum sample requirement of 60.

For the sake of further example the following facts are given:

Half of all relay schemes (1,000) are supplied with current signals from ANSI STD C800 bushing CTs and voltage signals from PTs built by ACME Electric MFR CO. All of the relay panels and cable pulls were built with consistent standards, and consistent performance standard expectations exist for the consistent wiring, cabling and instrument transformers within the segment (which is greater than 60).

The other half of the entity’s relay schemes have MPC relays with additional monitoring built-in that compare DNP values of voltages and currents (or watts and vars), as interpreted by the MPC relays and alarm for an entity-accepted tolerance level of accuracy. This newer segment of their “Voltage and Current Sensing” population is different than the original segment, consistent

(standards, construction and performance expectations) within the new segment and constitutes the remainder of the entity's population.

The entity is tracking many thousands of voltage and current signals within 2,000 relay schemes (each consisting of multiple voltage and current signals) in each of these two segments. But half of all of the relay schemes voltage and current signals are monitored; therefore, the voltage and current signals are continuously tested and the circuit will alarm when there is a failure; these alarms have to be verified every 12 years for correct operation.

The entity now has 1,000 relay schemes worth of voltage and current signals remaining that they have elected to count within their relay schemes designation. The entity has instituted a process that requires the verification of these voltage and current signals within each relay scheme (one unit).

(Please note - a problem discovered with a current or voltage signal found at the relay could be caused by anything from the relay, all the way to the signal source itself. Having many sources of problems can easily increase failure rates beyond the rate of failures of just one item (for example just PTs). It is the intent of the SDT to minimize failure rates of all of the equipment to an acceptable level; thus, any failure of any item that gets the signal from source to relay is counted. It is for this reason that the SDT chose to set the boundary at the ability of the signal to be delivered all the way to the relay.

The entity will start out measuring all of the relay scheme voltage and currents at the individual relays within the prescribed Table requirements (12 year max) by measuring the voltage and current values every 10 years. The entity's plan is to test 100 units per year; this is greater than the minimum sample size requirement of 30. For the sake of example only, the following will show three failures per year; reality may well have different numbers of failures every year. PBM requires annual assessment of failures found per units tested. After the first year of tests, the entity finds three failures in the 100 units tested. $3/100 = 3\%$ failure rate.

This entity is now allowed to extend the maintenance interval, if they choose. The entity chooses to extend the maintenance interval of this population segment out to 20 years. This represents a rate of 50 units tested per year; entity selects 50 units to be tested in the following year. After that year of testing these 50 units, the entity again finds three failed units. $3/50 = 6\%$ failures.

This entity has now exceeded the acceptable failure rate for these devices and must accelerate testing of all of the units at a higher rate, such that the failure rate is found to be less than 4% per year; the entity has three years to get this failure rate down to 4% or less (per year).

In response to the 6% failure rate, the entity decreases the testing interval to 16 years. This means that they will now test 63 units per year ($1000/16$). The entity has just two years left to get the test rate corrected. After a year, they again find three failures out of the 63 units tested. $3/63 = 4.76\%$ failures.

In response to the >4% failure rate, the entity decreases the testing interval to 14 years. This means that they will now test 72 units per year ($1000/14$). The entity has just one year left to get the test rate corrected. After a year, they again find three failures out of the 72 units tested. $3/72 = 4.2\%$ failures.

(Note that the entity has tried 10 years, and they were under the 4% limit; and they tried 14 years, and they were over the 4% limit. They must be back at 4% failures or less in the next year, so they might simply elect to go back to 10 years.)

Instead, in response to the 4.2% failure rate, the entity decreases the testing interval to 12 years. This means that they will now test 84 units per year (1,000/12). After a year, they again find three failures out of the 84 units tested. $3/84 = 3.6\%$ failures.

Entity found that they could maintain the failure rate at no more than 4% failures by maintaining the testing interval at 12 years or less. Entity chose 12-year interval and effectively extended their TBM (10 years) program by 20%.

A note of practicality is that an entity will probably be in better shape to lengthen the intervals between tests if the failure rate is less than 2%. But the requirements allow for annual adjustments, if the entity desires. As a matter of maintenance management, an ever-changing test rate (units tested/year) may be un-workable.

Note that the “5% of components” requirement effectively sets a practical limit of 20-year maximum PBM interval. Also of note is the “3 years” requirement; an entity might arbitrarily extend time intervals from six years to 20 years. In the event that an entity finds a failure rate greater than 4%, then the test rate must be accelerated such that within three years the failure rate must be brought back down to 4% or less.

Here is a table that demonstrates the values discussed:

Year #	Total Population (P)	Test Interval (I)	Units to be Tested (U= P/I)	# of Failures Found (F)	Failure Rate (=F/U)	Decision to Change Interval Yes or No	Interval Chose
1	1000	10 yrs	100	3	3%	Yes	20 yrs
2	1000	20 yrs	50	3	6%	Yes	16yrs
3	1000	16 yrs	63	3	4.8%	Yes	14 yrs
4	1000	14 yrs	72	3	4.2%	Yes	12 yrs
5	1000	12 yrs	84	3	3.6%	No	12 yrs

10. Overlapping the Verification of Sections of the Protection System

Tables 1-1 through 1-5 require that every Protection System component be periodically verified. One approach, but not the only method, is to test the entire protection scheme as a unit, from the secondary windings of voltage and current sources to breaker tripping. For practical ongoing verification, sections of the Protection System may be tested or monitored individually. The boundaries of the verified sections must overlap to ensure that there are no gaps in the verification. See Appendix A of this Supplementary Reference for additional discussion on this topic.

All of the methodologies expressed within this report may be combined by an entity, as appropriate, to establish and operate a maintenance program. For example, a Protection System may be divided into multiple overlapping sections with a different maintenance methodology for each section:

- Time-based maintenance with appropriate maximum verification intervals for categories of equipment, as given in the Tables 1-1 through 1-5;
- Monitoring as described in Tables 1-1 through 1-5;
- A Performance-Based Maintenance program as described in Section 9 above, or Attachment A of the standard;
- Opportunistic verification using analysis of Fault records, as described in Section 11

10.1 Frequently Asked Questions:

My system has alarms that are gathered once daily through an auto-polling system; this is not really a conventional SCADA system but does it meet the Table 1 requirements for inclusion as a monitored system?

Yes--provided the auto-polling that gathers the alarms reports those alarms to a location where the action can be initiated to correct the Unresolved Maintenance Issue. This location does not have to be the location of the engineer or the technician that will eventually repair the problem, but rather a location where the action can be initiated.

11. Monitoring by Analysis of Fault Records

Many users of microprocessor relays retrieve Fault event records and oscillographic records by data communications after a Fault. They analyze the data closely if there has been an apparent Misoperation, as NERC standards require. Some advanced users have commissioned automatic Fault record processing systems that gather and archive the data. They search for evidence of component failures or setting problems hidden behind an operation whose overall outcome seems to be correct. The relay data may be augmented with independently captured Digital Fault Recorder (DFR) data retrieved for the same event.

Fault data analysis comprises a legitimate CBM program that is capable of reducing the need for a manual time-interval based check on Protection Systems whose operations are analyzed. Even electromechanical Protection Systems instrumented with DFR channels may achieve some CBM benefit. The completeness of the verification then depends on the number and variety of Faults in the vicinity of the relay that produce relay response records and the specific data captured.

A typical Fault record will verify particular parts of certain Protection Systems in the vicinity of the Fault. For a given Protection System installation, it may or may not be possible to gather within a reasonable amount of time an ensemble of internal and external Fault records that completely verify the Protection System.

For example, Fault records may verify that the particular relays that tripped are able to trip via the control circuit path that was specifically used to clear that Fault. A relay or DFR record may indicate correct operation of the protection communications channel. Furthermore, other nearby Protection Systems may verify that they restrain from tripping for a Fault just outside their respective zones of protection. The ensemble of internal Fault and nearby external Fault event data can verify major portions of the Protection System, and reset the time clock for the Table 1 testing intervals for the verified components only.

What can be shown from the records of one operation is very specific and limited. In a panel with multiple relays, only the specific relay(s) whose operation can be observed without ambiguity should be used. Be careful about using Fault response data to verify that settings or calibration are correct. Unless records have been captured for multiple Faults close to either side of a setting boundary, setting or calibration could still be incorrect.

PMU data, much like DME data, can be utilized to prove various components of the Protection System. Obviously, care must be taken to attribute proof only to the parts of a Protection System that can actually be proven using the PMU or DME data.

If Fault record data is used to show that portions or all of a Protection System have been verified to meet Table 1 requirements, the owner must retain the Fault records used, and the maintenance-related conclusions drawn from this data and used to defer Table 1 tests, for at least the retention time interval given in Section 8.2.

11.1 Frequently Asked Questions:

I use my protective relays for Fault and Disturbance recording, collecting oscillographic records and event records via communications for Fault analysis to meet NERC and DME requirements. What are the maintenance requirements for the relays?

For relays used only as Disturbance Monitoring Equipment, NERC Standard PRC-018-1 R3 & R6 states the maintenance requirements and is being addressed by a standards activity that is revising PRC-002-1 and PRC-018-1. For protective relays “that are designed to provide protection for the BES,” this standard applies, even if they also perform DME functions.

12. Importance of Relay Settings in Maintenance Programs

In manual testing programs, many utilities depend on pickup value or zone boundary tests to show that the relays have correct settings and calibration. Microprocessor relays, by contrast, provide the means for continuously monitoring measurement accuracy. Furthermore, the relay digitizes inputs from one set of signals to perform all measurement functions in a single self-monitoring microprocessor system. These relays do not require testing or calibration of each setting.

However, incorrect settings may be a bigger risk with microprocessor relays than with older relays. Some microprocessor relays have hundreds or thousands of settings, many of which are critical to Protection System performance.

Monitoring does not check measuring element settings. Analysis of Fault records may or may not reveal setting problems. To minimize risk of setting errors after commissioning, the user should enforce strict settings data base management, with reconfirmation (manual or automatic) that the installed settings are correct whenever maintenance activity might have changed them; for background and guidance, see [5] in References.

Table 1 requires that settings must be verified to be as specified. The reason for this requirement is simple: With legacy relays (non-microprocessor protective relays), it is necessary to know the value of the intended setting in order to test, adjust and calibrate the relay. Proving that the relay works per specified setting was the de facto procedure. However, with the advanced microprocessor relays, it is possible to change relay settings for the purpose of verifying specific functions and then neglect to return the settings to the specified values. While there is no specific requirement to maintain a settings management process, there remains a need to verify that the settings left in the relay are the intended, specified settings. This need may manifest itself after any of the following:

- One or more settings are changed for any reason.
- A relay fails and is repaired or replaced with another unit.
- A relay is upgraded with a new firmware version.

12.1 Frequently Asked Questions:

How do I approach testing when I have to upgrade firmware of a microprocessor relay?

The entity should ensure that the relay continues to function properly after implementation of firmware changes. Some entities may have a Research and Development (R&D) department that might routinely run acceptance tests on devices with firmware upgrades before allowing the upgrade to be installed. Other entities may rely upon the vigorous testing of the firmware OEM. An entity has the latitude to install devices and/or programming that they believe will perform to their satisfaction. If an entity should choose to perform the maintenance activities specified in the Tables following a firmware upgrade, then they may, if they choose, reset the time clock on that set of maintenance activities so that they would not have to repeat the maintenance on

its regularly scheduled cycle. (However, for simplicity in maintenance schedules, some entities may choose to not reset this time clock; it is merely a suggested option.)

If I upgrade my old relays, then do I have to maintain my previous equipment maintenance documentation?

If an equipment item is repaired or replaced, then the entity can restart the maintenance-activity-time-interval-clock, if desired; however, the replacement of equipment does not remove any documentation requirements. The requirements in the standard are intended to ensure that an entity has a maintenance plan, and that the entity adheres to minimum activities and maximum time intervals. The documentation requirements are intended to help an entity demonstrate compliance. For example, saving the dates and records of the last two maintenance activities is intended to demonstrate compliance with the interval. Therefore, if you upgrade or replace equipment, then you still must maintain the documentation for the previous equipment, thus demonstrating compliance with the time interval requirement prior to the replacement action.

We have a number of installations where we have changed our Protection System components. Some of the changes were upgrades, but others were simply system rating changes that merely required taking relays “out-of-service”. What are our responsibilities when it comes to “out-of-service” devices?

Assuming that your system up-rates, upgrades and overall changes meet any and all other requirements and standards, then the requirements of PRC-005-6 are simple – if the Protection System component performs a Protection System function, then it must be maintained. If the component no longer performs Protection System functions, then it does not require maintenance activities under the Tables of PRC-005-6. While many entities might physically remove a component that is no longer needed, there is no requirement in PRC-005-6 to remove such component(s). Obviously, prudence would dictate that an “out-of-service” device is truly made inactive. There are no record requirements listed in PRC-005-6 for Protection System components not used.

While performing relay testing of a protective device on our Bulk Electric System, it was discovered that the protective device being tested was either broken or out of calibration. Does this satisfy the relay testing requirement, even though the protective device tested bad, and may be unable to be placed back into service?

Yes, PRC-005-6 requires entities to perform relay testing on protective devices on a given maintenance cycle interval. By performing this testing, the entity has satisfied PRC-005-6 requirement, although the protective device may be unable to be returned to service under normal calibration adjustments. Requirement R5 states:

“R5. Each Transmission Owner, Generator Owner, and Distribution Provider shall demonstrate efforts to correct any identified Unresolved Maintenance Issues.”

Also, when a failure occurs in a Protection System, power system security may be comprised, and notification of the failure must be conducted in accordance with relevant NERC standards.

If I show the protective device out of service while it is being repaired, then can I add it back as a new protective device when it returns? If not, my relay testing history would show that I was out of compliance for the last maintenance cycle.

The maintenance and testing requirements (Requirement R5) state “...shall demonstrate efforts to correct any identified Unresolved Maintenance Issues...” The type of corrective activity is not stated; however, it could include repairs or replacements.

Your documentation requirements will increase, of course, to demonstrate that your device tested bad and had corrective actions initiated. Your regional entity might ask about the status of your corrective actions.

13. Self-Monitoring Capabilities and Limitations

Microprocessor relay proponents have cited the self-monitoring capabilities of these products for nearly 20 years. Theoretically, any element that is monitored does not need a periodic manual test. A problem today is that the community of manufacturers and users has not created clear documentation of exactly what is and is not monitored. Some unmonitored but critical elements are buried in installed systems that are described as self-monitoring.

To utilize the extended time intervals allowed by monitoring, the user must document that the monitoring attributes of the device match the minimum requirements listed in the Table 1.

Until users are able to document how all parts of a system which are required for the protective functions are monitored or verified (with help from manufacturers), they must continue with the unmonitored intervals established in Tables 1, 3, 4 and 5 and any associated sub-tables.

Going forward, manufacturers and users can develop mappings of the monitoring within relays, and monitoring coverage by the relay of user circuits connected to the relay terminals.

To enable the use of the most extensive monitoring (and never again have a hands-on maintenance requirement), the manufacturers of the microprocessor-based self-monitoring components in the Protection System should publish for the user a document or map that shows:

- How all internal elements of the product are monitored for any failure that could impact Protection System performance.
- Which connected circuits are monitored by checks implemented within the product; how to connect and set the product to assure monitoring of these connected circuits; and what circuits or potential problems are not monitored.

This manufacturer's information can be used by the registered entity to document compliance of the monitoring attributes requirements by:

- Presenting or referencing the product manufacturer's documents.
- Explaining in a system design document the mapping of how every component and circuit that is critical to protection is monitored by the microprocessor product(s) or by other design features.
- Extending the monitoring to include the alarm transmission Facilities through which failures are reported within a given time frame to allocate where action can be taken to initiate resolution of the alarm attributed to an Unresolved Maintenance Issue, so that failures of monitoring or alarming systems also lead to alarms and action.
- Documenting the plans for verification of any unmonitored components according to the requirements of Tables 1, 3, 4 and 5 and any associated sub-tables.

13.1 Frequently Asked Questions:

I can't figure out how to demonstrate compliance with the requirements for the highest level of monitoring of Protection Systems. Why does this Maintenance Standard describe a maintenance program approach I cannot achieve?

Demonstrating compliance with the requirements for the highest level of monitoring any particular component of Protection Systems is likely to be very involved, and may include detailed manufacturer documentation of complete internal monitoring within a device, comprehensive design drawing reviews, and other detailed documentation. This standard does not presume to specify what documentation must be developed; only that it must be documented.

There may actually be some equipment available that is capable of meeting these highest levels of monitoring criteria, in which case it may be maintained according to the highest level of monitoring shown on the Tables. However, even if there is no equipment available today that can meet this level of monitoring, the standard establishes the necessary requirements for when such equipment becomes available.

By creating a roadmap for development, this provision makes the standard technology-neutral. The Standard Drafting Team wants to avoid the need to revise the standard in a few years to accommodate technology advances that may be coming to the industry.

14. Notification of Protection System or Automatic Reclosing Failures

When a failure occurs in a Protection System or Automatic Reclosing, power system security may be compromised, and notification of the failure must be conducted in accordance with relevant NERC standard(s). Knowledge of the failure may impact the system operator's decisions on acceptable Loading conditions.

This formal reporting of the failure and repair status to the system operator by the Protection System or Automatic Reclosing owner also encourages the system owner to execute repairs as rapidly as possible. In some cases, a microprocessor relay or carrier set can be replaced in hours; wiring termination failures may be repaired in a similar time frame. On the other hand, a component in an electromechanical or early-generation electronic relay may be difficult to find and may hold up repair for weeks. In some situations, the owner may have to resort to a temporary protection panel, or complete panel replacement.

15. Maintenance Activities

Some specific maintenance activities are a requirement to ensure reliability. An example would be that a BES entity could be prudent in its protective relay maintenance, but if its battery maintenance program is lacking, then reliability could still suffer. The NERC glossary outlines a Protection System as containing specific components. PRC-005-6 requires specific maintenance activities be accomplished within a specific time interval. As noted previously, higher technology equipment can contain integral monitoring capability that actually performs maintenance verification activities routinely and often; therefore, *manual intervention* to perform certain activities on these type components may not be needed.

15.1 Protective Relays (Table 1-1)

These relays are defined as the devices that receive the input signal from the current and voltage sensing devices and are used to isolate a Faulted Element of the BES. Devices that sense thermal, vibration, seismic, gas, or any other non-electrical inputs are excluded.

Non-microprocessor based equipment is treated differently than microprocessor-based equipment in the following ways; the relays should meet the asset owners' tolerances:

- Non-microprocessor devices must be tested with voltage and/or current applied to the device.
- Microprocessor devices may be tested through the integral testing of the device.
 - There is no specific protective relay commissioning test or relay routine test mandated.
 - There is no specific documentation mandated.

15.1.1 Frequently Asked Questions:

What calibration tolerance should be applied on electromechanical relays?

Each entity establishes their own acceptable tolerances when applying protective relaying on their system. For some Protection System components, adjustment is required to bring measurement accuracy within the parameters established by the asset owner based on the specific application of the component. A calibration failure is the result if testing finds the specified parameters to be out of tolerance.

15.2 Voltage & Current Sensing Devices (Table 1-3)

These are the current and voltage sensing devices, usually known as instrument transformers. There is presently a technology available (fiber-optic Hall-effect) that does not utilize conventional transformer technology; these devices and other technologies that produce quantities that represent the primary values of voltage and current are considered to be a type of voltage and current sensing devices included in this standard.

The intent of the maintenance activity is to verify the input to the protective relay from the device that produces the current or voltage signal sample.

There is no specific test mandated for these components. The important thing about these signals is to know that the expected output from these components actually reaches the protective relay. Therefore, the proof of the proper operation of these components also demonstrates the integrity of the wiring (or other medium used to convey the signal) from the current and voltage sensing device, all the way to the protective relay. The following observations apply:

- There is no specific ratio test, routine test or commissioning test mandated.
- There is no specific documentation mandated.
- It is required that the signal be present at the relay.
- This expectation can be arrived at from any of a number of means; including, but not limited to, the following: By calculation, by comparison to other circuits, by commissioning tests, by thorough inspection, or by any means needed to verify the circuit meets the asset owner's Protection System maintenance program.
- An example of testing might be a saturation test of a CT with the test values applied at the relay panel; this, therefore, tests the CT, as well as the wiring from the relay all the back to the CT.
- Another possible test is to measure the signal from the voltage and/or current sensing devices, during Load conditions, at the input to the relay.
- Another example of testing the various voltage and/or current sensing devices is to query the microprocessor relay for the Real-time Loading; this can then be compared to other devices to verify the quantities applied to this relay. Since the input devices have supplied the proper values to the protective relay, then the verification activity has been satisfied. Thus, event reports (and oscillographs) can be used to verify that the voltage and current sensing devices are performing satisfactorily.
- Still another method is to measure total watts and vars around the entire bus; this should add up to zero watts and zero vars, thus proving the voltage and/or current sensing devices system throughout the bus.
- Another method for proving the voltage and/or current-sensing devices is to complete commissioning tests on all of the transformers, cabling, fuses and wiring.
- Any other method that verifies the input to the protective relay from the device that produces the current or voltage signal sample.

15.2.1 Frequently Asked Questions:

What is meant by "...verify the current and voltage circuit inputs from the voltage and current sensing devices to the protective relays ..." Do we need to perform ratio, polarity and saturation tests every few years?

No--you must verify that the protective relay is receiving the expected values from the voltage and current-sensing devices (typically voltage and current transformers). This can be as difficult as is proposed by the question (with additional testing on the cabling and substation wiring to ensure that the values arrive at the relays); or simplicity can be achieved by other verification methods. While some examples follow, these are not intended to represent an all-inclusive list; technology advances and ingenuity should not be excluded from making comparisons and verifications:

- Compare the secondary values, at the relay, to a metering circuit, fed by different current transformers, monitoring the same line as the questioned relay circuit.
- Compare the individual phase secondary values at the relay panel (with additional testing on the panel wiring to ensure that the values arrive at those relays) with the other phases, and verify that residual currents are within expected bounds.
- Observe all three phase currents and the residual current at the relay panel with an oscilloscope, observing comparable magnitudes and proper phase relationship, with additional testing on the panel wiring to ensure that the values arrive at the relays.
- Compare the values, as determined by the questioned relay (such as, but not limited to, a query to the microprocessor relay) to another protective relay monitoring the same line, with currents supplied by different CTs.
- Compare the secondary values, at the relay with values measured by test instruments (such as, but not limited to multi-meters, voltmeter, clamp-on ammeters, etc.) and verified by calculations and known ratios to be the values expected. For example, a single PT on a 100 KV bus will have a specific secondary value that, when multiplied by the PT ratio, arrives at the expected bus value of 100 KV.
- Query SCADA for the power flows at the far end of the line protected by the questioned relay, compare those SCADA values to the values as determined by the questioned relay.
- Totalize the watts and vars on the bus and compare the totals to the values as seen by the questioned relay.

The point of the verification procedure is to ensure that all of the individual components are functioning properly; and that an ongoing proactive procedure is in place to re-check the various components of the protective relay measuring Systems.

Is wiring insulation or hi-pot testing required by this Maintenance Standard?

No--wiring insulation and equipment hi-pot testing are not specifically required by the Maintenance Standard. However, if the method of verifying CT and PT inputs to the relay involves some other method than actual observation of current and voltage transformer secondary inputs to the relay, it might be necessary to perform some sort of cable integrity test to verify that the instrument transformer secondary signals are actually making it to the relay and not being

shunted off to ground. For instance, you could use CT excitation tests and PT turns ratio tests and compare to baseline values to verify that the instrument transformer outputs are acceptable. However, to conclude that these acceptable transformer instrument output signals are actually making it to the relay inputs, it also would be necessary to verify the insulation of the wiring between the instrument transformer and the relay.

My plant generator and transformer relays are electromechanical and do not have metering functions, as do microprocessor-based relays. In order for me to compare the instrument transformer inputs to these relays to the secondary values of other metered instrument transformers monitoring the same primary voltage and current signals, it would be necessary to temporarily connect test equipment, like voltmeters and clamp on ammeters, to measure the input signals to the relays. This practice seems very risky, and a plant trip could result if the technician were to make an error while measuring these current and voltage signals. How can I avoid this risk? Also, what if no other instrument transformers are available which monitor the same primary voltage or current signal?

Comparing the input signals to the relays to the outputs of other independent instrument transformers monitoring the same primary current or voltage is just one method of verifying the instrument transformer inputs to the relays, but is not required by the standard. Plants can choose how to best manage their risk. If online testing is deemed too risky, offline tests, such as, but not limited to, CT excitation test and PT turns ratio tests can be compared to baseline data and be used in conjunction with CT and PT secondary wiring insulation verification tests to adequately “verify the current and voltage circuit inputs from the voltage and current sensing devices to the protective relays...” while eliminating the risk of tripping an in service generator or transformer. Similarly, this same offline test methodology can be used to verify the relay input voltage and current signals to relays when there are no other instrument transformers monitoring available for purposes of signal comparison.

15.3 Control circuitry associated with protective functions (Table 1-5)

This component of Protection Systems includes the trip coil(s) of the circuit breaker, circuit switcher or any other interrupting device. It includes the wiring from the batteries to the relays. It includes the wiring (or other signal conveyance) from every trip output to every trip coil. It includes any device needed for the correct processing of the needed trip signal to the trip coil of the interrupting device; this requirement is meant to capture inputs and outputs to and from a protective relay that are necessary for the correct operation of the protective functions. In short, every trip path must be verified; the method of verification is optional to the asset owner. An example of testing methods to accomplish this might be to verify, with a volt-meter, the existence of the proper voltage at the open contacts, the open circuited input circuit and at the trip coil(s). As every parallel trip path has similar failure modes, each trip path from relay to trip coil must be verified. Each trip coil must be tested to trip the circuit breaker (or other interrupting device) at least once. There is a requirement to operate the circuit breaker (or other interrupting device) at least once every six years as part of the complete functional test. If a suitable monitoring system is installed that verifies every parallel trip path, then the manual-intervention testing of those parallel trip paths can be eliminated; however, the actual operation of the circuit breaker must still occur at least once every six years. This six-year tripping requirement can be completed as easily as tracking the Real-time Fault-clearing operations on the circuit breaker, or tracking the trip coil(s) operation(s) during circuit breaker routine maintenance actions.

The circuit-interrupting device should not be confused with a motor-operated disconnect. The intent of this standard is to require maintenance intervals and activities on Protection Systems equipment, and not just all system isolating equipment.

It is necessary, however, to classify a device that actuates a high-speed auto-closing ground switch as an interrupting device, if this ground switch is utilized in a Protection System and forces a ground Fault to occur that then results in an expected Protection System operation to clear the forced ground Fault. The SDT believes that this is essentially a transferred-tripping device without the use of communications equipment. If this high-speed ground switch is “...designed to provide protection for the BES...” then this device needs to be treated as any other Protection System component. The control circuitry would have to be tested within 12 years, and any electromechanically operated device will have to be tested every six years. If the spring-operated ground switch can be disconnected from the solenoid triggering unit, then the solenoid triggering unit can easily be tested without the actual closing of the ground blade.

The dc control circuitry also includes each auxiliary tripping relay (94) and each lock-out relay (86) that may exist in any particular trip scheme. If the lock-out relays (86) are electromechanical type components, then they must be trip tested. The PSMT SDT considers these components to share some similarities in failure modes as electromechanical protective relays; as such, there is a six-year maximum interval between mandated maintenance tasks unless PBM is applied.

Contacts of the 86 and/or 94 that pass the trip current on to the circuit interrupting device trip coils will have to be checked as part of the 12 year requirement. Contacts of the 86 and/or 94 lock relay that operate non-BES interrupting devices are not required. Normally-open contacts that are not used to pass a trip signal and normally-closed contacts do not have to be verified. Verification of the tripping paths is the requirement.

New technology is also accommodated here; there are some tripping systems that have replaced the traditional hard-wired trip circuitry with other methods of trip-signal conveyance such as fiber-optics. It is the intent of the PSMT SDT to include this, and any other, technology that is used to convey a trip signal from a protective relay to a circuit breaker (or other interrupting device) within this category of equipment. The requirement for these systems is verification of the tripping path.

Monitoring of the control circuit integrity allows for no maintenance activity on the control circuit (excluding the requirement to operate trip coils and electromechanical lockout and/or tripping auxiliary relays). Monitoring of integrity means to monitor for continuity and/or presence of voltage on each trip path. For Ethernet or fiber-optic control systems, monitoring of integrity means to monitor communication ability between the relay and the circuit breaker.

15.3.1 Frequently Asked Questions:

Is it permissible to verify circuit breaker tripping at a different time (and interval) than when we verify the protective relays and the instrument transformers?

Yes--provided the entire Protective System is tested within the individual component's maximum allowable testing intervals.

The Protection System Maintenance Standard describes requirements for verifying the tripping of circuit breakers. What is this telling me about maintenance of circuit breakers?

Requirements in PRC-005-6 are intended to verify the integrity of tripping circuits, including the breaker trip coil, as well as the presence of auxiliary supply (usually a battery) for energizing the trip coil if a protection function operates. Beyond this, PRC-005-6 sets no requirements for verifying circuit breaker performance, or for maintenance of the circuit breaker.

How do I test each dc Control Circuit trip path, as established in Table 1-5 “Protection System Control Circuitry (Trip coils and auxiliary relays)”?

Table 1-5 specifies that each breaker trip coil and lockout relays that carry trip current to a trip coil must be operated within the specified time period. The required operations may be via targeted maintenance activities, or by documented operation of these devices for other purposes such as Fault clearing.

Are high-speed ground switch trip coils included in the dc control circuitry?

Yes--PRC-005-6 includes high-speed grounding switch trip coils within the dc control circuitry to the degree that the initiating Protection Systems are characterized as “transmission Protection Systems.”

Does the control circuitry and trip coil of a non-BES breaker, tripped via a BES protection component, have to be tested per Table 1.5? (Refer to Table 3 for examples 1 and 2)

Example 1: A non-BES circuit breaker that is tripped via a Protection System to which PRC-005-6 applies might be (but is not limited to) a 12.5KV circuit breaker feeding (non-black-start) radial Loads but has a trip that originates from an under-frequency (81) relay.

- The relay must be verified.
- The voltage signal to the relay must be verified.
- All of the relevant dc supply tests still apply.
- The unmonitored trip circuit between the relay and any lock-out or auxiliary relay must be verified every 12 years.
- The unmonitored trip circuit between the lock-out (or auxiliary relay) and the non-BES breaker does not have to be proven with an electrical trip.
- In the case where there is no lock-out or auxiliary tripping relay used, the trip circuit to the non-BES breaker does not have to be proven with an electrical trip.
- The trip coil of the non-BES circuit breaker does not have to be individually proven with an electrical trip.

Example 2: A Transmission Owner may have a non-BES breaker that is tripped via a Protection System to which PRC-005-6 applies, which may be (but is not limited to) a 13.8 KV circuit breaker feeding (non-black-start) radial Loads but has a trip that originates from a BES 115KV line relay.

- The relay must be verified
- The voltage signal to the relay must be verified
- All of the relevant dc supply tests still apply

-
- The unmonitored trip circuit between the relay and any lock-out (86) or auxiliary (94) relay must be verified every 12 years
 - The unmonitored trip circuit between the lock-out (86) (or auxiliary (94)) relay and the non-BES breaker does not have to be proven with an electrical trip
 - In the case where there is no lockout (86) or auxiliary (94) tripping relay used, the trip circuit to the non-BES breaker does not have to be proven with an electrical trip.
 - The trip coil of the non-BES circuit breaker does not have to be individually proven with an electrical trip

Example 3: A Generator Owner may have a non-BES circuit breaker that is tripped via a Protection System to which PRC-005-6 applies, such as the generator field breaker and low-side breakers on station service/excitation transformers connected to the generator bus.

Trip testing of the generator field breaker and low side station service/excitation transformer breaker(s) via lockout or auxiliary tripping relays are not required since these breakers may be associated with radially fed loads and are not considered to be BES breakers. An example of an otherwise non-BES circuit breaker that is tripped via a BES protection component might be (but is not limited to) a 6.9kV station service transformer source circuit breaker but has a trip that originates from a generator differential (87) relay.

- The differential relay must be verified.
- The current signals to the relay must be verified.
- All of the relevant dc supply tests still apply.
- The unmonitored trip circuit between the relay and any lock-out or auxiliary relay must be verified every 12 years.
- The unmonitored trip circuit between the lock-out (or auxiliary relay) and the non-BES breaker does not have to be proven with an electrical trip.
- In the case where there is no lock-out or auxiliary tripping relay used, the trip circuit to the non-BES breaker does not have to be proven with an electrical trip.
- The trip coil of the non-BES circuit breaker does not have to be individually proven with an electrical trip.

However, it is very prudent to verify the tripping of such breakers for the integrity of the overall generation plant.

Do I have to verify operation of breaker "a" contacts or any other normally closed auxiliary contacts in the trip path of each breaker as part of my control circuit test?

Operation of normally-closed contacts does not have to be verified. Verification of the tripping paths is the requirement. The continuity of the normally closed contacts will be verified when the tripping path is verified.

15.4 Batteries and DC Supplies (Table 1-4)

The NERC definition of a Protection System is:

- Protective relays which respond to electrical quantities,

-
- Communications Systems necessary for correct operation of protective functions,
 - Voltage and current sensing devices providing inputs to protective relays,
 - Station dc supply associated with protective functions (including station batteries, battery chargers, and non-battery-based dc supply), and
 - Control circuitry associated with protective functions through the trip coil(s) of the circuit breakers or other interrupting devices.

The station battery is not the only component that provides dc power to a Protection System. In the new definition for Protection System, “station batteries” are replaced with “station dc supply” to make the battery charger and dc producing stored energy devices (that are not a battery) part of the Protection System that must be maintained.

The PSMT SDT recognizes that there are several technological advances in equipment and testing procedures that allow the owner to choose how to verify that a battery string is free of open circuits. The term “continuity” was introduced into the standard to allow the owner to choose how to verify continuity of a battery set by various methods, and not to limit the owner to other conventional methods of showing continuity. Continuity, as used in Table 1-4 of the standard, refers to verifying that there is a continuous current path from the positive terminal of the station battery set to the negative terminal. Without verifying continuity of a station battery, there is no way to determine that the station battery is available to supply dc power to the station. An open battery string will be an unavailable power source in the event of loss of the battery charger.

Batteries cannot be a unique population segment of a Performance-Based Maintenance Program (PBM) because there are too many variables in the electrochemical process to completely isolate all of the performance-changing criteria necessary for using PBM on battery Systems. However, nothing precludes the use of a PBM process for any other part of a dc supply besides the batteries themselves.

15.4.1 Frequently Asked Questions:

What constitutes the station dc supply, as mentioned in the definition of Protective System?

The previous definition of Protection System includes batteries, but leaves out chargers. The latest definition includes chargers, as well as dc systems that do not utilize batteries. This revision of PRC-005-6 is intended to capture these devices that were not included under the previous definition. The station direct current (dc) supply normally consists of two components: the battery charger and the station battery itself. There are also emerging technologies that provide a source of dc supply that does not include either a battery or charger.

Battery Charger - The battery charger is supplied by an available ac source. At a minimum, the battery charger must be sized to charge the battery (after discharge) and supply the constant dc load. In many cases, it may be sized also to provide sufficient dc current to handle the higher energy requirements of tripping breakers and switches when actuated by the protective relays in the Protection System.

Station Battery - Station batteries provide the dc power required for tripping and for supplying normal dc power to the station in the event of loss of the battery charger. There are several technologies of battery that require unique forms of maintenance as established in Table 1-4.

Emerging Technologies - Station dc supplies are currently being developed that use other energy storage technologies besides the station battery to prevent loss of the station dc supply when ac power is lost. Maintenance of these station dc supplies will require different kinds of tests and inspections. Table 1-4 presents maintenance activities and maximum allowable testing intervals for these new station dc supply technologies. However, because these technologies are relatively new, the maintenance activities for these station dc supplies may change over time.

What did the PSMT SDT mean by “continuity” of the dc supply?

The PSMT SDT recognizes that there are several technological advances in equipment and testing procedures that allow the owner to choose how to verify that a battery string is free of open circuits. The term “continuity” was introduced into the standard to allow the owner to choose how to verify continuity (no open circuits) of a battery set by various methods, and not to limit the owner to other conventional methods of showing continuity--lack of an open circuit. Continuity, as used in Table 1-4 of the standard, refers to verifying that there is a continuous current path from the positive terminal of the station battery set to the negative terminal (no open circuit). Without verifying continuity of a station battery, there is no way to determine that the station battery is available to supply dc power to the station. Whether it is caused from an open cell or a bad external connection, an open battery string will be an unavailable power source in the event of loss of the battery charger.

The current path through a station battery from its positive to its negative connection to the dc control circuits is composed of two types of elements. These path elements are the electrochemical path through each of its cells and all of the internal and external metallic connections and terminations of the batteries in the battery set. If there is loss of continuity (an open circuit) in any part of the electrochemical or metallic path, the battery set will not be available for service. In the event of the loss of the ac source or battery charger, the battery must be capable of supplying dc current, both for continuous dc loads and for tripping breakers and switches. Without continuity, the battery cannot perform this function.

At generating stations and large transmission stations where battery chargers are capable of handling the maximum current required by the Protection System, there are still problems that could potentially occur when the continuity through the connected battery is interrupted.

- Many battery chargers produce harmonics which can cause failure of dc power supplies in microprocessor-based protective relays and other electronic devices connected to station dc supply. In these cases, the substation battery serves as a filter for these harmonics. With the loss of continuity in the battery, the filter provided by the battery is no longer present.
- Loss of electrical continuity of the station battery will cause, in most battery chargers, regardless of the battery charger’s output current capability, a delayed response in full output current from the charger. Almost all chargers have an intentional one- to two-second delay to switch from a low substation dc load current to the maximum output of the charger. This delay would cause the opening of circuit breakers to be delayed, which could violate system performance standards.

Monitoring of the station dc supply voltage will not indicate that there is a problem with the dc current path through the battery, unless the battery charger is taken out of service. At that time,

a break in the continuity of the station battery current path will be revealed because there will be no voltage on the station dc circuitry. This particular test method, while proving battery continuity, may not be acceptable to all installations.

Although the standard prescribes what must be accomplished during the maintenance activity, it does not prescribe how the maintenance activity should be accomplished. There are several methods that can be used to verify the electrical continuity of the battery. These are not the only possible methods, simply a sampling of some methods:

- One method is to measure that there is current flowing through the battery itself by a simple clamp on milliamp-range ammeter. A battery is always either charging or discharging. Even when a battery is charged, there is still a measurable float charge current that can be detected to verify that there is continuity in the electrical path through the battery.
- A simple test for continuity is to remove the battery charger from service and verify that the battery provides voltage and current to the dc system. However, the behavior of the various dc-supplied equipment in the station should be considered before using this approach.
- Manufacturers of microprocessor-controlled battery chargers have developed methods for their equipment to periodically (or continuously) test for battery continuity. For example, one manufacturer periodically reduces the float voltage on the battery until current from the battery to the dc load can be measured to confirm continuity.
- Applying test current (as in some ohmic testing devices, or devices for locating dc grounds) will provide a current that when measured elsewhere in the string, will prove that the circuit is continuous.
- Internal ohmic measurements of the cells and units of lead-acid batteries (valve-regulated lead-acid (VRLA) & vented lead-acid (VLA)) can detect lack of continuity within the cells of a battery string; and when used in conjunction with resistance measurements of the battery's external connections, can prove continuity. Also some methods of taking internal ohmic measurements, by their very nature, can prove the continuity of a battery string without having to use the results of resistance measurements of the external connections.
- Specific gravity tests could infer continuity because without continuity there could be no charging occurring; and if there is no charging, then specific gravity will go down below acceptable levels over time.

No matter how the electrical continuity of a battery set is verified, it is a necessary maintenance activity that must be performed at the intervals prescribed by Table 1-4 to insure that the station dc supply has a path that can provide the required current to the Protection System at all times.

When should I check the station batteries to see if they have sufficient energy to perform as manufactured?

The answer to this question depends on the type of battery (valve-regulated lead-acid, vented lead-acid, or nickel-cadmium) and the maintenance activity chosen.

For example, if you have a VRLA) station battery, and you have chosen to evaluate the measured cell/unit internal ohmic values to the battery cell's baseline, you will have to perform

verification at a maximum maintenance interval of no greater than every six months. While this interval might seem to be quite short, keep in mind that the six-month interval is important for VRLA batteries; this interval provides an accumulation of data that better shows when a VRLA battery is incapable of performing as manufactured.

If, for a VRLA station battery, you choose to conduct a performance capacity test on the entire station battery as the maintenance activity, then you will have to perform verification at a maximum maintenance interval of no greater than every three calendar years.

How is a baseline established for cell/unit internal ohmic measurements?

Establishment of cell/unit internal ohmic baseline measurements should be completed when lead-acid batteries are newly installed. To ensure that the baseline ohmic cell/unit values are most indicative of the station battery's ability to perform as manufactured, they should be made at some point in time after the installation to allow the cell chemistry to stabilize after the initial freshening charge. An accepted industry practice for establishing baseline values is after six-months of installation, with the battery fully charged and in service. However, it is recommended that each owner, when establishing a baseline, should consult the battery manufacturer for specific instructions on establishing an ohmic baseline for their product, if available.

When internal ohmic measurements are taken, the same make/model test equipment should be used to establish the baseline and used for the future trending of the cells internal ohmic measurements because of variances in test equipment and the type of ohmic measurement used by different manufacturer's equipment. Keep in mind that one manufacturer's "conductance" test equipment does not produce similar results as another manufacturer's "conductance" test equipment, even though both manufacturers have produced "ohmic" test equipment. Therefore, for meaningful results to an established baseline, the same make/model of instrument should be used.

For all new installations of VRLA batteries and VLA batteries, where trending of the cells internal ohmic measurements to a baseline are to be used to determine the ability of the station battery to perform as manufactured, the establishment of the baseline, as described above, should be followed at the time of installation to insure the most accurate trending of the cell/unit. However, often for older VRLA batteries, the owners of the station batteries have not established a baseline at installation. Also for owners of VLA batteries who want to establish a maintenance activity which requires trending of measured ohmic values to a baseline, there was typically no baseline established at installation of the station battery to trend to.

To resolve the problem of the unavailability of baseline internal ohmic measurements for the individual cell/unit of a station battery, many manufacturers of internal ohmic measurement devices have established libraries of baseline values for VRLA and VLA batteries using their testing device. Also, several of the battery manufacturers have libraries of baselines for their products that can be used to trend to. However, it is important that when using battery manufacturer-supplied data that it is verified that the baseline readings to be used were taken with the same ohmic testing device that will be used for future measurements (for example "conductance readings" from one manufacturer's test equipment do not correlate to "impedance readings" from a different manufacturer's test equipment). Although many manufacturers may have provided baseline values, which will allow trending of the internal ohmic measurements over the remaining life of a station battery, these baselines are not the actual cell/unit measurements for

the battery being trended. It is important to have a baseline tailored to the station battery to more accurately use the tool of ohmic measurement trending. That more customized baseline can only be created by following the establishment of a baseline for each cell/unit at the time of installation of the station battery.

Why determine the State of Charge?

Even though there is no present requirement to check the state of charge of a battery, it can be a very useful tool in determining the overall condition of a battery system. The following discussions are offered as a general reference.

When a battery is fully charged, the battery is available to deliver its existing capacity. As a battery is discharged, its ability to deliver its maximum available capacity is diminished. It is necessary to determine if the state of charge has dropped to an unacceptable level.

What is State of Charge and how can it be determined in a station battery?

The state of charge of a battery refers to the ratio of residual capacity at a given instant to the maximum capacity available from the battery. When a battery is fully charged, the battery is available to deliver its existing capacity. As a battery is discharged, its ability to deliver its maximum available capacity is diminished. Knowing the amount of energy left in a battery compared with the energy it had when it was fully charged gives the user an indication of how much longer a battery will continue to perform before it needs recharging.

For VLA batteries which use accessible liquid electrolyte, a hydrometer can be used to test the specific gravity of each cell as a measure of its state of charge. The hydrometer depends on measuring changes in the weight of the active chemicals. As the battery discharges, the active electrolyte, sulfuric acid, is consumed and the concentration of the sulfuric acid in water is reduced. This, in turn, reduces the specific gravity of the solution in direct proportion to the state of charge. The actual specific gravity of the electrolyte can, therefore, be used as an indication of the state of charge of the battery. Hydrometer readings may not tell the whole story, as it takes a while for the acid to get mixed up in the cells of a VLA battery. If measured right after charging, you might see high specific gravity readings at the top of the cell, even though it is much less at the bottom. Conversely, if taken shortly after adding water to the cell, the specific gravity readings near the top of the cell will be lower than those at the bottom.

Nickel-cadmium batteries, where the specific gravity of the electrolyte does not change during battery charge and discharge, and VRLA batteries, where the electrolyte is not accessible, cannot have their state of charge determined by specific gravity readings. For these two types of batteries, and for VLA batteries also, where another method besides taking hydrometer readings is desired, the state of charge may be determined by taking voltage and current readings at the battery terminals. The methods employed to obtain accurate readings vary for the different battery types. Manufacturers' information and IEEE guidelines can be consulted for specifics; (see IEEE 1106 Annex B for Nickel Cadmium batteries, IEEE 1188 Annex A for VRLA batteries and IEEE 450 for VLA batteries.

Why determine the Connection Resistance?

High connection resistance can cause abnormal voltage drop or excessive heating during discharge of a station battery. During periods of a high rate of discharge of the station battery, a very high resistance can cause severe damage. The maintenance requirement to verify battery terminal connection resistance in Table 1-4 is established to verify that the integrity of all battery electrical connections is acceptable. This verification includes cell-to-cell (intercell) and external

circuit terminations. Your method of checking for acceptable values of intercell and terminal connection resistance could be by individual readings, or a combination of the two. There are test methods presently that can read post termination resistances and resistance values between external posts. There are also test methods presently available that take a combination reading of the post termination connection resistance plus the intercell resistance value plus the post termination connection resistance value. Either of the two methods, or any other method, that can show if the adequacy of connections at the battery posts is acceptable.

Adequacy of the electrical terminations can be determined by comparing resistance measurements for all connections taken at the time of station battery's installation to the same resistance measurements taken at the maintenance interval chosen, not to exceed the maximum maintenance interval of Table 1-4. Trending of the interval measurements to the baseline measurements will identify any degradation in the battery connections. When the connection resistance values exceed the acceptance criteria for the connection, the connection is typically disassembled, cleaned, reassembled and measurements taken to verify that the measurements are adequate when compared to the baseline readings.

What conditions should be inspected for visible battery cells?

The maintenance requirement to inspect the cell condition of all station battery cells where the cells are visible is a maintenance requirement of Table 1-4. Station batteries are different from any other component in the Protection Station because they are a perishable product due to the electrochemical process which is used to produce dc electrical current and voltage. This inspection is a detailed visual inspection of the cells for abnormalities that occur in the aging process of the cell. In VLA battery visual inspections, some of the things that the inspector is typically looking for on the plates are signs of sulfation of the plates, abnormal colors (which are an indicator of sulfation or possible copper contamination) and abnormal conditions such as cracked grids. The visual inspection could look for symptoms of hydration that would indicate that the battery has been left in a completely discharged state for a prolonged period. Besides looking at the plates for signs of aging, all internal connections, such as the bus bar connection to each plate, and the connections to all posts of the battery need to be visually inspected for abnormalities. In a complete visual inspection for the condition of the cell the cell plates, separators and sediment space of each cell must be looked at for signs of deterioration. An inspection of the station battery's cell condition also includes looking at all terminal posts and cell-to-cell electric connections to ensure they are corrosion free. The case of the battery containing the cell, or cells, must be inspected for cracks and electrolyte leaks through cracks and the post seals.

This maintenance activity cannot be extended beyond the maximum maintenance interval of Table 1-4 by a Performance-Based Maintenance Program (PBM) because of the electrochemical aging process of the station battery, nor can there be any monitoring associated with it because there must be a visual inspection involved in the activity. A remote visual inspection could possibly be done, but its interval must be no greater than the maximum maintenance interval of Table 1-4.

Why is it necessary to verify the battery string can perform as manufactured? I only care that the battery can trip the breaker, which means that the battery can perform as designed. I oversize my batteries so that even if the battery cannot perform as manufactured, it can still trip my breakers.

The fundamental answer to this question revolves around the concept of battery performance “as designed” vs. battery performance “as manufactured.” The purpose of the various sections of Table 1-4 of this standard is to establish requirements for the Protection System owner to maintain the batteries, to ensure they will operate the equipment when there is an incident that requires dc power, and ensure the batteries will continue to provide adequate service until at least the next maintenance interval. To meet these goals, the correct battery has to be properly selected to meet the design parameters, and the battery has to deliver the power it was manufactured to provide.

When testing batteries, it may be difficult to determine the original design (i.e., load profile) of the dc system. This standard is not intended as a design document, and requirements relating to design are, therefore, not included.

Where the dc load profile is known, the best way to determine if the system will operate as designed is to conduct a service test on the battery. However, a service test alone might not fully determine if the battery is healthy. A battery with 50% capacity may be able to pass a service test, but the battery would be in a serious state of deterioration and could fail at some point in the near future.

To ensure that the battery will meet the required load profile and continue to meet the load profile until the next maintenance interval, the installed battery must be sized correctly (i.e., a correct design), and it must be in a good state of health. Since the design of the dc system is not within the scope of the standard, the only consistent and reliable method to ensure that the battery is in a good state of health is to confirm that it can perform as manufactured. If the battery can perform as manufactured and it has been designed properly, the system should operate properly until the next maintenance interval.

How do I verify the battery string can perform as manufactured?

Optimally, actual battery performance should be verified against the manufacturer’s rating curves. The best practice for evaluating battery performance is via a performance test. However, due to both logistical and system reliability concerns, some Protection System owners prefer other methods to determine if a battery can perform as manufactured. There are several battery parameters that can be evaluated to determine if a battery can perform as manufactured. Ohmic measurements and float current are two examples of parameters that have been reported to assist in determining if a battery string can perform as manufactured.

The evaluation of battery parameters in determining battery health is a complex issue, and is not an exact science. This standard gives the user an opportunity to utilize other measured parameters to determine if the battery can perform as manufactured. It is the responsibility of the Protection System owner, however, to maintain a documented process that demonstrates the chosen parameter(s) and associated methodology used to determine if the battery string can perform as manufactured.

Whatever parameters are used to evaluate the battery (ohmic measurements, float current, float voltages, temperature, specific gravity, performance test, or combination thereof), the goal is to determine the value of the measurement (or the percentage change) at which the battery fails

to perform as manufactured, or the point where the battery is deteriorating so rapidly that it will not perform as manufactured before the next maintenance interval.

This necessitates the need for establishing and documenting a baseline. A baseline may be required of every individual cell, a particular battery installation, or a specific make, model, or size of a cell. Given a consistent cell manufacturing process, it may be possible to establish a baseline number for the cell (make/model/type) and, therefore, a subsequent baseline for every installation would not be necessary. However, future installations of the same battery types should be spot-checked to ensure that your baseline remains applicable.

Consistent testing methods by trained personnel are essential. Moreover, it is essential that these technicians utilize the same make/model of ohmic test equipment each time readings are taken in order to establish a meaningful and accurate trend line against the established baseline. The type of probe and its location (post, connector, etc.) for the reading need to be the same for each subsequent test. The room temperature should be recorded with the readings for each test as well. Care should be taken to consider any factors that might lead a trending program to become invalid.

Float current along with other measurable parameters can be used in lieu of or in concert with ohmic measurement testing to measure the ability of a battery to perform as manufactured. The key to using any of these measurement parameters is to establish a baseline and the point where the reading indicates that the battery will not perform as manufactured.

The establishment of a baseline may be different for various types of cells and for different types of installations. In some cases, it may be possible to obtain a baseline number from the battery manufacturer, although it is much more likely that the baseline will have to be established after the installation is complete. To some degree, the battery may still be “forming” after installation; consequently, determining a stable baseline may not be possible until several months after the battery has been in service.

The most important part of this process is to determine the point where the ohmic reading (or other measured parameter(s)) indicates that the battery cannot perform as manufactured. That point could be an absolute number, an absolute change, or a percentage change of an established baseline.

Since there are no universally-accepted repositories of this information, the Protection System owner will have to determine the value/percentage where the battery cannot perform as manufactured (heretofore referred to as a failed cell). This is the most difficult and important part of the entire process.

To determine the point where the battery fails to perform as manufactured, it is helpful to have a history of a battery type, if the data includes the parameter(s) used to evaluate the battery's ability to perform as manufactured against the actual demonstrated performance/capacity of a battery/cell.

For example, when an ohmic reading has been recorded that the user suspects is indicating a failed cell, a performance test of that cell (or string) should be conducted in order to prove/quantify that the cell has failed. Through this process, the user needs to determine the ohmic value at which the performance of the cell has dropped below 80% of the manufactured, rated performance. It is likely that there may be a variation in ohmic readings that indicates a

failed cell (possibly significant). It is prudent to use the most conservative values to determine the point at which the cell should be marked for replacement. Periodically, the user should demonstrate that an “adequate” ohmic reading equates to an adequate battery performance (>80% of capacity).

Similarly, acceptance criteria for "good" and "failed" cells should be established for other parameters such as float current, specific gravity, etc., if used to determine the ability of a battery to function as designed.

What happens if I change the make/model of ohmic test equipment after the battery has been installed for a period of time?

If a user decides to switch testers, either voluntarily or because the equipment is not supported/sold any longer, the user may have to establish a new base line and new parameters that indicate when the battery no longer performs as manufactured. The user always has a choice to perform a capacity test in lieu of establishing new parameters.

What are some of the differences between lead-acid and nickel-cadmium batteries?

There is a marked difference in the aging process of lead acid and nickel-cadmium station batteries. The difference in the aging process of these two types of batteries is chiefly due to the electrochemical process of the battery type. Aging and eventual failure of lead acid batteries is due to expansion and corrosion of the positive grid structure, loss of positive plate active material, and loss of capacity caused by physical changes in the active material of the positive plates. In contrast, the primary failure of nickel-cadmium batteries is due to the gradual linear aging of the active materials in the plates. The electrolyte of a nickel-cadmium battery only facilitates the chemical reaction (it functions only to transfer ions between the positive and negative plates), but is not chemically altered during the process like the electrolyte of a lead acid battery. A lead acid battery experiences continued corrosion of the positive plate and grid structure throughout its operational life while a nickel-cadmium battery does not.

Changes to the properties of a lead acid battery when periodically measured and trended to a baseline, can indicate aging of the grid structure, positive plate deterioration, or changes in the active materials in the plate.

Because of the clear differences in the aging process of lead acid and nickel-cadmium batteries, there are no significantly measurable properties of the nickel-cadmium battery that can be measured at a periodic interval and trended to determine aging. For this reason, Table 1-4(c) (Protection System Station dc supply Using nickel-cadmium [NiCad] Batteries) only specifies one minimum maintenance activity and associated maximum maintenance interval necessary to verify that the station battery can perform as manufactured by evaluating cell/unit measurements indicative of battery performance against the station battery baseline. This maintenance activity is to conduct a performance or modified performance capacity test of the entire battery bank.

Why in Table 1-4 of PRC-005-6 is there a maintenance activity to inspect the structural integrity of the battery rack?

The purpose of this inspection is to verify that the battery rack is correctly installed and has no deterioration that could weaken its structural integrity.

Because the battery rack is specifically manufactured for the battery that is mounted on it, weakening of its structural members by rust or corrosion can physically jeopardize the battery.

What is required to comply with the “Unintentional dc Grounds” requirement?

In most cases, the first ground that appears on a battery is not a problem. It is the unintentional ground that appears on the opposite pole that becomes problematic. Even then many systems are designed to operate favorably under some unintentional dc ground situations. It is up to the owner of the Protection System to determine if corrective actions are needed on detected unintentional dc grounds. The standard merely requires that a check be made for the existence of unintentional dc grounds. Obviously, a “check-off” of some sort will have to be devised by the inspecting entity to document that a check is routinely done for unintentional dc grounds because of the possible consequences to the Protection System.

Where the standard refers to “all cells,” is it sufficient to have a documentation method that refers to “all cells,” or do we need to have separate documentation for every cell? For example, do I need 60 individual documented check-offs for good electrolyte level, or would a single check-off per bank be sufficient?

A single check-off per battery bank is sufficient for documentation, as long as the single check-off attests to checking all cells/units.

Does this standard refer to Station batteries or all batteries; for example, Communications Site Batteries?

This standard refers to Station Batteries. The drafting team does not believe that the scope of this standard refers to communications sites. The batteries covered under PRC-005-6 are the batteries that supply the trip current to the trip coils of the interrupting devices that are a part of the Protection System. The SDT believes that a loss of power to the communications systems at a remote site would cause the communications systems associated with protective relays to alarm at the substation. At this point, the corrective actions can be initiated.

What are cell/unit internal ohmic measurements?

With the introduction of VRLA batteries to station dc supplies in the 1980’s several of the standard maintenance tools that are used on VLA batteries were unable to be used on this new type of lead-acid battery to determine its state of health. The only tools that were available to give indication of the health of these new VRLA batteries were voltage readings of the total battery voltage, the voltage of the individual cells and periodic discharge tests.

In the search for a tool for determining the health of a VRLA battery several manufacturers studied the electrical model of a lead acid battery’s current path through its cell. The overall battery current path consists of resistance and inductive and capacitive reactance. The inductive reactance in the current path through the battery is so minuscule when compared to the huge capacitive reactance of the cells that it is often ignored in most circuit models of the battery cell. Taking the basic model of a battery cell manufacturers of battery test equipment have developed and marketed testing devices to take measurements of the current path to detect degradation in the internal path through the cell.

In the battery industry, these various types of measurements are referred to as ohmic measurements. Terms used by the industry to describe ohmic measurements are ac conductance, ac impedance, and dc resistance. They are defined by the test equipment providers and IEEE and refer to the method of taking ohmic measurements of a lead acid battery. For example, in one manufacturer’s ac conductance equipment measurements are taken by applying a voltage of a known frequency and amplitude across a cell or battery unit and observing the ac

current flow it produces in response to the voltage. A manufacturer of an ac impedance meter measures ac current of a known frequency and amplitude that is passed through the whole battery string and determines the impedances of each cell or unit by measuring the resultant ac voltage drop across them. On the other hand, dc resistance of a cell is measured by a third manufacturer's equipment by applying a dc load across the cell or unit and measuring the step change in both the voltage and current to calculate the internal dc resistance of the cell or unit.

It is important to note that because of the rapid development of the market for ohmic measurement devices, there were no standards developed or used to mandate the test signals used in making ohmic measurements. Manufacturers using proprietary methods and applying different frequencies and magnitudes for their signals have developed a diversity of measurement devices. This diversity in test signals coupled with the three different types of ohmic measurements techniques (impedance conductance and resistance) make it impossible to always get the same ohmic measurement for a cell with different ohmic measurement devices. However, IEEE has recognized the great value for choosing one device for ohmic measurement, no matter who makes it or the method to calculate the ohmic measurement. The only caution given by IEEE and the battery manufacturers is that when trending the cells of a lead acid station battery consistent ohmic measurement devices should be used to establish the baseline measurement and to trend the battery set for its entire life.

For VRLA batteries both IEEE Standard 1188 (Maintenance, Testing and Replacement of VRLA Batteries) and IEEE Standard 1187 (Installation Design and Installation of VRLA Batteries) recognize the importance of the maintenance activity of establishing a baseline for "cell/unit internal ohmic measurements (impedance, conductance and resistance)" and trending them at frequent intervals over the life of the battery. There are extensive discussions about the need for taking these measurements in these standards. IEEE Standard 1188 requires taking internal ohmic values as described in Annex C4 during regular inspections of the station battery. For VRLA batteries IEEE Standard 1188 in talking about the necessity of establishing a baseline and trending it over time says, "...depending on the degree of change a performance test, cell replacement or other corrective action may be necessary..." (IEEE std 1188-2005, C.4 page 18).

For VLA batteries IEEE Standard 484 (Installation of VLA batteries) gives several guidelines about establishing baseline measurements on newly installed lead acid stationary batteries. The standard also discusses the need to look for significant changes in the ohmic measurements, the caution that measurement data will differ with each type of model of instrument used, and lists a number of factors that affect ohmic measurements.

At the beginning of the 21st century, EPRI conducted a series of extensive studies to determine the relationship of internal ohmic measurements to the capacity of a lead acid battery cell. The studies indicated that internal ohmic measurements were in fact a good indicator of a lead acid battery cell's capacity, but because users often were only interested in the total station battery capacity and the technology does not precisely predict overall battery capacity, if a user only needs "an accurate measure of the overall battery capacity," they should "perform a battery capacity test."

Prior to the EPRI studies some large and small companies which owned and maintained station dc supplies in NERC Protection Systems developed maintenance programs where trending of ohmic measurements of cells/units of the station's battery became the maintenance activity for determining if the station battery could perform as manufactured. By evaluation of the trending

of the ohmic measurements over time, the owner could track the performance of the individual components of the station battery and determine if a total station battery or components of it required capacity testing, removal, replacement or in many instances replacement of the entire station battery. By taking this condition based approach these owners have eliminated having to perform capacity testing at prescribed intervals to determine if a battery needs to be replaced and are still able to effectively determine if a station battery can perform as manufactured.

My VRLA batteries have multiple-cells within an individual battery jar (or unit); how am I expected to comply with the cell-to-cell ohmic measurement requirements on these units that I cannot get to?

Measurement of cell/unit (not all batteries allow access to “individual cells” some “units” or jars may have multiple cells within a jar) internal ohmic values of all types of lead acid batteries where the cells of the battery are not visible is a station dc supply maintenance activity in Table 1-4. In cases where individual cells in a multi-cell unit are inaccessible, an ohmic measurement of the entire unit may be made.

I have a concern about my batteries being used to support additional auxiliary loads beyond my protection control systems in a generation station. Is ohmic measurement testing sufficient for my needs?

While this standard is focused on addressing requirements for Protection Systems, if batteries are used to service other load requirements beyond that of Protection Systems (e.g. pumps, valves, inverter loads), the functional entity may consider additional testing to confirm that the capacity of the battery is sufficient to support all loads.

Why verify voltage?

There are two required maintenance activities associated with verification of dc voltages in Table 1-4. These two required activities are to verify station dc supply voltage and float voltage of the battery charger, and have different maximum maintenance intervals. Both of these voltage verification requirements relate directly to the battery charger maintenance.

The verification of the dc supply voltage is simply an observation of battery voltage to prove that the charger has not been lost or is not malfunctioning; a reading taken from the battery charger panel meter or even SCADA values of the dc voltage could be some of the ways that one could satisfy the requirements. Low battery voltage below float voltage indicates that the battery may be on discharge and, if not corrected, the station battery could discharge down to some extremely low value that will not operate the Protection System. High voltage, close to or above the maximum allowable dc voltage for equipment connected to the station dc supply indicates the battery charger may be malfunctioning by producing high dc voltage levels on the Protection System. If corrective actions are not taken to bring the high voltage down, the dc power supplies and other electronic devices connected to the station dc supply may be damaged. The maintenance activity of verifying the float voltage of the battery charger is not to prove that a charger is lost or producing high voltages on the station dc supply, but rather to prove that the charger is properly floating the battery within the proper voltage limits. As above, there are many ways that this requirement can be met.

Why check for the electrolyte level?

In VLA and nickel-cadmium (NiCad) batteries the visible electrolyte level must be checked as one of the required maintenance activities that must be performed at an interval that is equal to or less than the maximum maintenance interval of Table 1-4. Because the electrolyte level in VRLA batteries cannot be observed, there is no maintenance activity listed in Table 1-4 of the standard for checking the electrolyte level. Low electrolyte level of any cell of a VLA or NiCad station battery is a condition requiring correction. Typically, the electrolyte level should be returned to an acceptable level for both types of batteries (VLA and NiCad) by adding distilled or other approved-quality water to the cell.

Often people confuse the interval for watering all cells required due to evaporation of the electrolyte in the station battery cells with the maximum maintenance interval required to check the electrolyte level. In many of the modern station batteries, the jar containing the electrolyte is so large with the band between the high and low electrolyte level so wide that normal evaporation which would require periodic watering of all cells takes several years to occur. However, because loss of electrolyte due to cracks in the jar, overcharging of the station battery, or other unforeseen events can cause rapid loss of electrolyte; the shorter maximum maintenance intervals for checking the electrolyte level are required. A low level of electrolyte in a VLA battery cell which exposes the tops of the plates can cause the exposed portion of the plates to accelerated sulfation resulting in loss of cell capacity. Also, in a VLA battery where the electrolyte level goes below the end of the cell withdrawal tube or filling funnel, gasses can exit the cell by the tube instead of the flame arrester and present an explosion hazard.

What are the parameters that can be evaluated in Tables 1-4(a) and 1-4(b)?

The most common parameter that is periodically trended and evaluated by industry today to verify that the station battery can perform as manufactured is internal ohmic cell/unit measurements.

In the mid-1990s, several large and small utilities began developing maintenance and testing programs for Protection System station batteries using a condition based maintenance approach of trending internal ohmic measurements to each station battery cell's baseline value. Battery owners use the data collected from this maintenance activity to determine (1) when a station battery requires a capacity test (instead of performing a capacity test on a predetermined, prescribed interval), (2) when an individual cell or battery unit should be replaced, or (3) based on the analysis of the trended data, if the station battery should be replaced without performing a capacity test.

Other examples of measurable parameters that can be periodically trended and evaluated for lead acid batteries are cell voltage, float current, connection resistance. However, periodically trending and evaluating cell/unit Ohmic measurements are the most common battery/cell parameters that are evaluated by industry to verify a lead acid battery string can perform as manufactured.

Why does it appear that there are two maintenance activities in Table 1-4(b) (for VRLA batteries) that appear to be the same activity and have the same maximum maintenance interval?

There are two different and distinct reasons for doing almost the same maintenance activity at the same interval for VRLA batteries. The first similar activity for VRLA batteries (Table 1-4(b))

that has the same maximum maintenance interval is to “measure battery cell/unit internal ohmic values.” Part of the reason for this activity is because the visual inspection of the cell condition is unavailable for VRLA batteries. Besides the requirement to measure the internal ohmic measurements of VRLA batteries to determine the internal health of the cell, the maximum maintenance interval for this activity is significantly shorter than the interval for VLA due to some unique failure modes for VRLA batteries. Some of the potential problems that VRLA batteries are susceptible to that do not affect VLA batteries are thermal runaway, cell dry-out, and cell reversal when one cell has a very low capacity.

The other similar activity listed in Table 1-4(b) is “...verify that the station battery can perform as manufactured by evaluating the measured cell/unit measurements indicative of battery performance (e.g. internal ohmic values) against the station battery baseline.” This activity allows an owner the option to choose between this activity with its much shorter maximum maintenance interval or the longer maximum maintenance interval for the maintenance activity to “Verify that the station battery can perform as manufactured by conducting a performance or modified performance capacity test of the entire battery bank.”

For VRLA batteries, there are two drivers for internal ohmic readings. The first driver is for a means to trend battery life. Trending against the baseline of VRLA cells in a battery string is essential to determine the approximate state of health of the battery. Ohmic measurement testing may be used as the mechanism for measuring the battery cells. If all the cells in the string exhibit a consistent trend line and that trend line has not risen above a specific deviation (e.g. 30%) over baseline for impedance tests or below baseline for conductance tests, then a judgment can be made that the battery is still in a reasonably good state of health and able to ‘perform as manufactured.’ It is essential that the specific deviation mentioned above is based on data (test or otherwise) that correlates the ohmic readings for a specific battery/tester combination to the health of the battery. This is the intent of the “perform as manufactured six-month test” at Row 4 on Table 1-4b.

The second big driver is VRLA batteries tendency for thermal runaway. This is the intent of the “thermal runaway test” at Row 2 on Table 1-4b. In order to detect a cell in thermal runaway, you need not necessarily have a formal trending program. When a single cell/unit changes significantly or significantly varies from the other cells (e.g. a doubling of resistance/impedance or a 50% decrease in conductance), there is a high probability that the cell/unit/string needs to be replaced as soon as possible. In other words, if the battery is 10 years old and all the cells have approached a significant change in ohmic values over baseline, then you have a battery which is approaching end of life. You need to get ready to buy a new battery, but you do not have to worry about an impending catastrophic failure. On the other hand, if the battery is five years old and you have one cell that has a markedly different ohmic reading than all the other cells, then you need to be worried that this cell is susceptible to thermal runaway. If the float (charging) current has risen significantly and the ohmic measurement has increased/decreased as described above then concern of catastrophic failure should trigger attention for corrective action.

If an entity elects to use a capacity test rather than a cell ohmic value trending program, this does not eliminate the need to be concerned about thermal runaway--the entity still needs to do the six-month readings and look for cells which are outliers in the string but they need not trend

results against the factory/as new baseline. Some entities will not mind the extra administrative burden of having the ongoing trending program against baseline--others would rather just do the capacity test and not have to trend the data against baseline. Nonetheless, all entities must look for ohmic outliers on a six-month basis.

It is possible to accomplish both tasks listed (trend testing for capability and testing for thermal runaway candidates) with the very same ohmic test. It becomes an analysis exercise of watching the trend from baselines and watching for the oblique cell measurement.

In table 1-4(f) (Exclusions for Protection System Station dc Supply Monitoring Devices and Systems), must all component attributes listed in the table be met before an exclusion can be granted for a maintenance activity?

Table 1-4(f) was created by the drafting team to allow Protection System dc supply owners to obtain exclusions from periodic maintenance activities by using monitoring devices. The basis of the exclusions granted in the table is that the monitoring devices must incorporate the monitoring capability of microprocessor based components which perform continuous self-monitoring. For failure of the microprocessor device used in dc supply monitoring, the self-checking routine in the microprocessor must generate an alarm which will be reported within 24 hours of device failure to a location where corrective action can be initiated.

Table 1-4(f) lists 8 component attributes along with a specific periodic maintenance activity associated with each of the 8 attributes listed. If an owner of a station dc supply wants to be excluded from periodically performing one of the 8 maintenance activities listed in table 1-4(f), the owner must have evidence that the monitoring and alarming component attributes associated with the excluded maintenance activity are met by the self-checking microprocessor based device with the specific component attribute listed in the table 1-4(f).

For example if an owner of a VLA station battery does not want to “verify station dc supply voltage” every “4 calendar months” (see table 1-4(a)), the owner can install a monitoring and alarming device “with high and low voltage monitoring and alarming of the battery charger voltage to detect charger overvoltage and charger failure” and “no periodic verification of station dc supply voltage is required” (see table 1-4(f) first row). However, if for the same Protection System discussed above, the owner does not install “electrolyte level monitoring and alarming in every cell” and “unintentional dc ground monitoring and alarming” (see second and third rows of table 1-4(f)), the owner will have to “inspect electrolyte level and for unintentional grounds” every “4 calendar months” (see table 1-4(a)).

15.5 Associated communications equipment (Table 1-2)

The equipment used for tripping in a communications-assisted trip scheme is a vital piece of the trip circuit. Remote action causing a local trip can be thought of as another parallel trip path to the trip coil that must be tested. Besides the trip output and wiring to the trip coil(s), there is also a communications medium that must be maintained. Newer technologies now exist that achieve communications-assisted tripping without the conventional wiring practices of older technology. For example, older technologies may have included Frequency Shift Key methods. This technology requires that guard and trip levels be maintained. The actual tripping path(s) to the trip coil(s) may be tested as a parallel trip path within the dc control circuitry tests. Emerging technologies transfer digital information over a variety of carrier mediums that are then interpreted locally as trip signals. The requirements apply to the communicated signal needed

for the proper operation of the protective relay trip logic or scheme. Therefore, this standard is applied to equipment used to convey both trip signals (permissive or direct) and block signals.

It was the intent of this standard to require that a test be performed on any communications-assisted trip scheme, regardless of the vintage of technology. The essential element is that the tripping (or blocking) occurs locally when the remote action has been asserted; or that the tripping (or blocking) occurs remotely when the local action is asserted. Note that the required testing can still be done within the concept of testing by overlapping segments. Associated communications equipment can be (but is not limited to) testing at other times and different frequencies as the protective relays, the individual trip paths and the affected circuit interrupting devices.

Some newer installations utilize digital signals over fiber-optics from the protective relays in the control house to the circuit interrupting device in the yard. This method of tripping the circuit breaker, even though it might be considered communications, must be maintained per the dc control circuitry maintenance requirements.

15.5.1 Frequently Asked Questions:

What are some examples of mechanisms to check communications equipment functioning?

For unmonitored Protection Systems, various types of communications systems will have different facilities for on-site integrity checking to be performed at least every four months during a substation visit. Some examples are, but not limited to:

- On-off power-line carrier systems can be checked by performing a manual carrier keying test between the line terminals, or carrier check-back test from one terminal.
- Systems which use frequency-shift communications with a continuous guard signal (over a telephone circuit, analog microwave system, etc.) can be checked by observing for a loss-of-guard indication or alarm. For frequency-shift power-line carrier systems, the guard signal level meter can also be checked.
- Hard-wired pilot wire line Protection Systems typically have pilot-wire monitoring relays that give an alarm indication for a pilot wire ground or open pilot wire circuit loop.
- Digital communications systems typically have a data reception indicator or data error indicator (based on loss of signal, bit error rate, or frame error checking).

For monitored Protection Systems, various types of communications systems will have different facilities for monitoring the presence of the communications channel, and activating alarms that can be monitored remotely. Some examples are, but not limited to:

- On-off power-line carrier systems can be shown to be operational by automated periodic power-line carrier check-back tests with remote alarming of failures.
- Systems which use a frequency-shift communications with a continuous guard signal (over a telephone circuit, analog microwave system, etc.) can be remotely monitored with a loss-of-guard alarm or low signal level alarm.

-
- Hard-wired pilot wire line Protection Systems can be monitored by remote alarming of pilot-wire monitoring relays.
 - Digital communications systems can activate remotely monitored alarms for data reception loss or data error indications.
 - Systems can be queried for the data error rates.

For the highest degree of monitoring of Protection Systems, the communications system must monitor all aspects of the performance and quality of the channel that show it meets the design performance criteria, including monitoring of the channel interface to protective relays.

- In many communications systems signal quality measurements, including signal-to-noise ratio, received signal level, reflected transmitter power or standing wave ratio, propagation delay, and data error rates are compared to alarm limits. These alarms are connected for remote monitoring.
- Alarms for inadequate performance are remotely monitored at all times, and the alarm communications system to the remote monitoring site must itself be continuously monitored to assure that the actual alarm status at the communications equipment location is continuously being reflected at the remote monitoring site.

What is needed for the four-month inspection of communications-assisted trip scheme equipment?

The four-month inspection applies to unmonitored equipment. An example of compliance with this requirement might be, but is not limited to:

With each site visit, check that the equipment is free from alarms; check any metered signal levels, and that power is still applied. While this might be explicit for a particular type of equipment (i.e., FSK equipment), the concept should be that the entity verify that the communications equipment that is used in a Protection System is operable through a cursory inspection and site visit. This site visit can be eliminated on this particular example if the FSK equipment had a monitored alarm on Loss of Guard. Blocking carrier systems with auto checkbacks will present an alarm when the channel fails allowing a visual indication. With no auto checkback, the channel integrity will need to be verified by a manual checkback or a two ended signal check. This check could also be eliminated by bring the auto checkback failure alarm to the monitored central location.

Does a fiber optic I/O scheme used for breaker tripping or control within a station, for example - transmitting a trip signal or control logic between the control house and the breaker control cabinet, constitute a communications system?

This equipment is presently classified as being part of the Protection System control circuitry and tested per the portions of Table 1 applicable to “Protection System Control Circuitry”, rather than those portions of the table applicable to communications equipment.

What is meant by “Channel” and “Communications Systems” in Table 1-2?

The transmission of logic or data from a relay in one station to a relay in another station for use in a pilot relay scheme will require a communications system of some sort. Typical relay communications systems use fiber optics, leased audio channels, power line carrier, and microwave. The overall communications system includes the channel and the associated communications equipment.

This standard refers to the “channel” as the medium between the transmitters and receivers in the relay panels such as a leased audio or digital communications circuit, power line and power line carrier auxiliary equipment, and fiber. The dividing line between the channel and the associated communications equipment is different for each type of media.

Examples of the Channel:

- Power Line Carrier (PLC) - The PLC channel starts and ends at the PLC transmitter and receiver output unless there is an internal hybrid. The channel includes the external hybrids, tuners, wave traps and the power line itself.
- Microwave –The channel includes the microwave multiplexers, radios, antennae and associated auxiliary equipment. The audio tone and digital transmitters and receivers in the relay panel are the associated communications equipment.
- Digital/Audio Circuit – The channel includes the equipment within and between the substations. The associated communications equipment includes the relay panel transmitters and receivers and the interface equipment in the relays.
- Fiber Optic – The channel starts at the fiber optic connectors on the fiber distribution panel at the local station and goes to the fiber optic distribution panel at the remote substation. The jumpers that connect the relaying equipment to the fiber distribution panel and any optical-electrical signal format converters are the associated communications equipment.

Figure 1-2, A-1 and A-2 at the end of this document show good examples of the communications channel and the associated communications equipment.

In Table 1-2, the Maintenance Activities section of the Protection System Communications Equipment and Channels refers to the quality of the channel meeting “performance criteria.” What is meant by performance criteria?

Protection System communications channels must have a means of determining if the channel and communications equipment is operating normally. If the channel is not operating normally, an alarm will be indicated. For unmonitored systems, this alarm will probably be on the panel. For monitored systems, the alarm will be transmitted to a remote location.

Each entity will have established a nominal performance level for each Protection System communications channel that is consistent with proper functioning of the Protection System. If that level of nominal performance is not being met, the system will go into alarm. Following are some examples of Protection System communications channel performance measuring:

- For direct transfer trip using a frequency shift power line carrier channel, a guard level monitor is part of the equipment. A normal receive level is established when the system is calibrated and if the signal level drops below an established level, the system will indicate an alarm.
- An on-off blocking signal over power line carrier is used for directional comparison blocking schemes on transmission lines. During a Fault, block logic is sent to the remote relays by turning on a local transmitter and sending the signal over the power line to a receiver at the remote end. This signal is normally off so continuous levels cannot be checked. These schemes use check-back testing to determine channel performance. A

predetermined signal sequence is sent to the remote end and the remote end decodes this signal and sends a signal sequence back. If the sending end receives the correct information from the remote terminal, the test passes and no alarm is indicated. Full power and reduced power tests are typically run. Power levels for these tests are determined at the time of calibration.

- Pilot wire relay systems use a hardwire communications circuit to communicate between the local and remote ends of the protective zone. This circuit is monitored by circulating a dc current between the relay systems. A typical level may be 1 mA. If the level drops below the setting of the alarm monitor, the system will indicate an alarm.
- Modern digital relay systems use data communications to transmit relay information to the remote end relays. An example of this is a line current differential scheme commonly used on transmission lines. The protective relays communicate current magnitude and phase information over the communications path to determine if the Fault is located in the protective zone. Quantities such as digital packet loss, bit error rate and channel delay are monitored to determine the quality of the channel. These limits are determined and set during relay commissioning. Once set, any channel quality problems that fall outside the set levels will indicate an alarm.

The previous examples show how some protective relay communications channels can be monitored and how the channel performance can be compared to performance criteria established by the entity. This standard does not state what the performance criteria will be; it just requires that the entity establish nominal criteria so Protection System channel monitoring can be performed.

How is the performance criteria of Protection System communications equipment involved in the maintenance program?

An entity determines the acceptable performance criteria, depending on the technology implemented. If the communications channel performance of a Protection System varies from the pre-determined performance criteria for that system, then these results should be investigated and resolved.

How do I verify the A/D converters of microprocessor-based relays?

There are a variety of ways to do this. Two examples would be: using values gathered via data communications and automatically comparing these values with values from other sources, or using groupings of other measurements (such as vector summation of bus feeder currents) for comparison. Many other methods are possible.

15.6 Alarms (Table 2)

In addition to the tables of maintenance for the components of a Protection System, there is an additional table added for alarms. This additional table was added for clarity. This enabled the common alarm attributes to be consolidated into a single spot, and, thus, make it easier to read the Tables 1-1 through 1-5, Table 3, and Table 4. The alarms need to arrive at a site wherein a corrective action can be initiated. This could be a control room, operations center, etc. The alarming mechanism can be a standard alarming system or an auto-polling system; the only requirement is that the alarm be brought to the action-site within 24 hours. This effectively makes manned-stations equivalent to monitored stations. The alarm of a monitored point (for example a monitored trip path with a lamp) in a manned-station now makes that monitored point eligible for monitored status. Obviously, these same rules apply to a non-manned-station, which

is that if the monitored point has an alarm that is auto-reported to the operations center (for example) within 24 hours, then it too is considered monitored.

15.6.1 Frequently Asked Questions:

Why are there activities defined for varying degrees of monitoring a Protection System component when that level of technology may not yet be available?

There may already be some equipment available that is capable of meeting the highest levels of monitoring criteria listed in the Tables. However, even if there is no equipment available today that can meet this level of monitoring the standard establishes the necessary requirements for when such equipment becomes available. By creating a roadmap for development, this provision makes the standard technology neutral. The Standard Drafting Team wants to avoid the need to revise the standard in a few years to accommodate technology advances that may be coming to the industry.

Does a fail-safe “form b” contact that is alarmed to a 24/7 operation center classify as an alarm path with monitoring?

If the fail-safe “form-b” contact that is alarmed to a 24/7 operation center causes the alarm to activate for failure of any portion of the alarming path from the alarm origin to the 24/7 operations center, then this can be classified as an alarm path with monitoring.

15.7 Distributed UFLS and Distributed UVLS Systems (Table 3)

Distributed UFLS and distributed UVLS systems have their maintenance activities documented in Table 3 due to their distributed nature allowing reduced maintenance activities and extended maximum maintenance intervals. Relays have the same maintenance activities and intervals as Table 1-1. Voltage and current-sensing devices have the same maintenance activity and interval as Table 1-3. DC systems need only have their voltage read at the relay every 12 years. Control circuits have the following maintenance activities every 12 years:

- Verify the trip path between the relay and lock-out and/or auxiliary tripping device(s).
- Verify operation of any lock-out and/or auxiliary tripping device(s) used in the trip circuit.
- No verification of trip path required between the lock-out (and/or auxiliary tripping device) and the non-BES interrupting device.
- No verification of trip path required between the relay and trip coil for circuits that have no lock-out and/or auxiliary tripping device(s).
- No verification of trip coil required.

No maintenance activity is required for associated communication systems for distributed UFLS and distributed UVLS schemes.

Non-BES interrupting devices that participate in a distributed UFLS or distributed UVLS scheme are excluded from the tripping requirement, and part of the control circuit test requirement; however, the part of the trip path control circuitry between the Load-Shed relay and lock-out or auxiliary tripping relay must be tested at least once every 12 years. In the case where there is no lock-out or auxiliary tripping relay used in a distributed UFLS or UVLS scheme which is not part of the BES, there is no control circuit test requirement. There are many circuit interrupting devices in the distribution system that will be operating for any given under-frequency event

that requires tripping for that event. A failure in the tripping action of a single distributed system circuit breaker (or non-BES equipment interruption device) will be far less significant than, for example, any single transmission Protection System failure, such as a failure of a bus differential lock-out relay. While many failures of these distributed system circuit breakers (or non-BES equipment interruption device) could add up to be significant, it is also believed that many circuit breakers are operated often on just Fault clearing duty; and, therefore, these circuit breakers are operated at least as frequently as any requirements that appear in this standard.

There are times when a Protection System component will be used on a BES device, as well as a non-BES device, such as a battery bank that serves both a BES circuit breaker and a non-BES interrupting device used for UFLS. In such a case, the battery bank (or other Protection System component) will be subject to the Tables of the standard because it is used for the BES.

15.7.1 Frequently Asked Questions:

The standard reaches further into the distribution system than we would like for UFLS and UVLS

While UFLS and UVLS equipment are located on the distribution network, their job is to protect the Bulk Electric System. This is not beyond the scope of NERC's Section 215 authority.

FPA section 215(a) definitions section defines bulk power system as: "(A) facilities and control Systems necessary for operating an interconnected electric energy transmission network (or any portion thereof)." That definition, then, is limited by a later statement which adds the term bulk power system "...does not include facilities used in the local distribution of electric energy." Also, Section 215 also covers users, owners, and operators of bulk power Facilities.

UFLS and UVLS (when the UVLS is installed to prevent system voltage collapse or voltage instability for BES reliability) are not "used in the local distribution of electric energy," despite their location on local distribution networks. Further, if UFLS/UVLS Facilities were not covered by the reliability standards, then in order to protect the integrity of the BES during under-frequency or under-voltage events, that Load would have to be shed at the Transmission bus to ensure the Load-generation balance and voltage stability is maintained on the BES.

15.8 Automatic Reclosing (Table 4)

Please see the document referenced in Section F of PRC-005-3, "Considerations for Maintenance and Testing of Autoreclosing Schemes — November 2012", for a discussion of Automatic Reclosing as addressed in PRC-005-3.

15.8.1 Frequently-asked Questions

Automatic Reclosing is a control, not a protective function; why then is Automatic Reclosing maintenance included in the Protection System Maintenance Program (PSMP)?

Automatic Reclosing is a control function. The standard's title 'Protection System and Automatic Reclosing Maintenance' clearly distinguishes (separates) the Automatic Reclosing from the Protection System. Automatic Reclosing is included in the PSMP because it is a more pragmatic approach as compared to creating a parallel and essentially identical 'Control System Maintenance Program' for the Automatic Reclosing component types.

When do I need to have the initial maintenance of Automatic Reclosing Components completed upon change of the largest BES generating unit in the BA/RSG?

The maintenance interval, for newly identified Automatic Reclosing Components, starts when a change in the largest BES generating unit is determined by the BA/RSG. The first maintenance records for newly identified Automatic Reclosing Components should be dated no later than the maximum maintenance interval after the identification date. The maximum maintenance intervals for each newly identified Component are defined in Table 4. No activities or records are required prior to the date of identification.

Our maintenance practice consists of initiating the Automatic Reclosing relay and confirming the breaker closes properly and the close signal is released. This practice verifies the control circuitry associated with Automatic Reclosing. Do you agree?"

The described task partially verifies the control circuit maintenance activity. To meet the control circuit maintenance activity, responsible entities need to verify, *upon initiation*, that the reclosing relay does not issue a *premature closing command*. As noted on page 12 of the SAMS/SPCS report, the concern being addressed within the standard is premature auto reclosing that has the potential to cause generating unit or plant instability. Reclosing applications have many variations, responsible entities will need to verify the applicability of associated supervision/conditional logic and the reclosing relay operation; then verify the conditional logic or that the reclosing relay performs in a manner that does not result in a *premature closing command* being issued.

Some examples of conditions which can result in a premature closing command are: an improper supervision or conditional logic input which provides a false state and allows the reclosing relay to issue an improper close command based on incorrect conditions (i.e. voltage supervision, equipment status, sync window verification); timers utilized for closing actuation or reclosing arming/disarming circuitry which could allow the reclosing relay to issue an improper close command; a reclosing relay output contact failure which could result in a made-up-close condition / failure-to-release condition.

Why was a close-in three phase fault present for twice the normal clearing time chosen for the Automatic Reclosing exclusion? It exceeds TPL requirements and ignores the breaker closing time in a trip-close-trip sequence, thus making the exclusion harder to attain.

This condition represents a situation where a close signal is issued with no time delay or with less time delay than is intended, such as if a reclosing contact is welded closed. This failure mode can result in a minimum trip-close-trip sequence with the two faults cleared in primary protection operating time, and the open time between faults equal to the breaker closing cycle time. The sequence for this failure mode results in system impact equivalent to a high-speed autoreclosing sequence with no delay added in the autoreclosing logic. It represents a failure mode which must be avoided because it exceeds TPL requirements.

Do we have to test the various breaker closing circuit interlocks and controls such as anti-pump?

These components are not specifically addressed within Table 4, and need not be individually tested.

For Automatic Reclosing that is not part of an RAS, do we have to close the circuit breaker periodically?

No--for this application, you need only to verify that the Automatic Reclosing, upon initiation, does not issue a premature closing command. This activity is concerned only with assuring that a premature close does not occur, and cause generating plant instability.

For Automatic Reclosing that is part of an RAS, do we have to close the circuit breaker periodically?

Yes--in this application, successful closing is a necessary portion of the RAS, and must be verified.

Why is maintenance of supervisory relays now included in PRC-005 for Automatic Reclosing?

Proper performance of supervising relays supports the reliability of the BES because some conditions can result in a premature closing command. An example of this would be an improper supervision or conditional logic input which provides a false state and allows the reclosing relay to issue an improper close command based on incorrect conditions (i.e. voltage supervision, sync window verification)

My reclosing circuitry contains the following inputs listed below.

- **79/ON – Supervisory contact which turns Automatic Reclosing ON or OFF**
- **52 – Supervisory contact which provides breaker indication (“b” contact)**
- **86 - Supervisory contact from a lockout relay**
- **79 – Supervisory contact from a reclosing relay**
- **25 – Supervisory contact from a sync-check relay**
- **27 or 59 – Supervisory contact from an undervoltage or overvoltage relay**

Which parts of the control circuitry would need to be verified, upon initiation, do not issue a premature close command per PRC-005?

Supervisory Relays are defined in this standard as “relay(s) that perform voltage and/or sync check functions that enables or disables operation of the reclosing relay.” The 79, 25, and 27 or 59 would need to be verified because they are supervisory devices that are associated with Automatic Reclosing. The 79/ON, 52, and 86 would not need to be verified.

The sync check and voltage check functions are part of my microprocessor reclosing relay. Are there any test requirements for these internal supervisory functions?

A microprocessor reclosing relay that is using internal sync check or voltage check supervisory functions is a combinational reclosing and supervisory relay (i.e. 79/25).). The maintenance activities for both a reclosing relay and supervisory relay would apply. The voltage sensing devices providing input to a combinational reclosing and supervisory relay would require the activities in Table 4-3.

Is it necessary to verify the close signal operates the breaker?

Only when the control circuitry associated with automatic reclosing is a part of a RAS, then all paths that are essential for proper operation of the RAS must be verified, per table 4-2(b).

15.9 Sudden Pressure Relaying (Table 5)

Please see the document referenced in Section F of PRC-005-6, “Sudden Pressure Relays and Other Devices that Respond to Non-Electrical Quantities – December 2013”, for a discussion of Sudden Pressure Relaying as addressed in PRC-005-6.

15.9.1 Frequently Asked Questions:

How do I verify the pressure or flow sensing mechanism is operable?

Maintenance activities for the fault pressure relay associated with Sudden Pressure Relaying in PRC-005-6 are intended to verify that the pressure and/or flow sensing mechanism are functioning correctly. Beyond this, PRC-005-6 requires no calibration (adjusting the operating threshold or measurement accuracy of a measuring element to meet the intended performance requirement) or testing (applying signals to a component to observe functional performance or output behavior, or to diagnose problems) activities. For example, some designs of flow sensing mechanisms allow the operation of a test switch to actuate the limit switch of the flow sensing mechanism. Operation of this test switch and verification of the flow sensing mechanism would meet the requirements of the maintenance activity. Another example involves a gas pressure sensing mechanism which is isolated by a test plug. Removal of the plug and verification of the bellows mechanism would meet the requirements of the maintenance activity.

Why the 6-year maximum maintenance interval for fault pressure relays?

The SDT established the six-year maintenance interval for fault pressure relays (see Table 5, PRC-005-6) based on the recommendation of the System Protection and Control Subcommittee (SPCS). The technical experts of the SPCS were tasked with developing the technical documents to:

- i. Describe the devices and functions (to include sudden pressure relays which trip for fault conditions) that should address FERC’s concern; and
- ii. Propose minimum maintenance activities for such devices and maximum maintenance intervals, including the technical basis for each.

Excerpt from the [SPCS technical report](#): “In order to determine present industry practices related to sudden pressure relay maintenance, the SPCS conducted a survey of Transmission Owners and Generator Owners in all eight Regions requesting information related to their maintenance practices.” The SPCS received responses from 75 Transmission Owners and 109 Generator Owners. Note that, for the purpose of the survey, sudden pressure relays included the following: the “sudden pressure relay” (SPR) originally manufactured by Westinghouse, the “rapid pressure rise relay” (RPR) manufactured by Qualitrol, and a variety of Buchholz relays.

Table 2 provides a summary of the results of the responses:

Table 2: Sudden Pressure Relay Maintenance Practices – Survey Results		
	Transmission Owner	Generator Owner
Number of responding owners that trip with Sudden Pressure Relays:	67	84
Percentage of responding owners who trip that have a Maintenance Program:	75%	78%
Percentage of maintenance programs that include testing the pressure actuator:	81%	77%
Average Maintenance interval reported:	5.9 years	4.9 years

Additionally, in order to validate the information noted above, the SPCS contacted the following entities for their feedback: the IEEE Power System Relaying Committee, the IEEE Transformer Committee, the Doble Transformer Committee, the NATF System Protection Practices Group, and the EPRI Generator Owner/Operator Technical Focus Group. All of these organizations indicated the results of the SPCS survey are consistent with their respective experiences.

The SPCS discussed the potential difference between the recommended intervals for fault pressure relaying and intervals for transformer maintenance. The SPCS developed the recommended intervals for fault pressure relaying by comparing fault pressure relaying to Protection System Components with similar physical attributes. The SPCS recognized that these intervals may be shorter than some existing or future transformer maintenance intervals, but believed it to be more important to base intervals for fault pressure relaying on similar Protection System Components than transformer maintenance intervals.

The maintenance interval for fault pressure relays can be extended by utilizing performance-based maintenance thereby allowing entities that have maintenance intervals for transformers in excess of six years, to align them.

Sudden Pressure Relaying control circuitry is now specifically mentioned in the maintenance tables. Do we have to trip our circuit breaker specifically from the trip output of the sudden pressure relay?

No--verification may be by breaker tripping, but may be verified in overlapping segments with the Protection System control circuitry.

Can we use Performance Based Maintenance for fault pressure relays?

Yes--performance Based Maintenance is applicable to fault pressure relays.

15.10 Examples of Evidence of Compliance

To comply with the requirements of this standard, an entity will have to document and save evidence. The evidence can be of many different forms. The Standard Drafting Team recognizes

that there are concurrent evidence requirements of other NERC standards that could, at times, fulfill evidence requirements of this standard.

15.10.1 Frequently Asked Questions:

What forms of evidence are acceptable?

Acceptable forms of evidence, as relevant for the requirement being documented include, but are not limited to:

- Process documents or plans
- Data (such as relay settings sheets, photos, SCADA, and test records)
- Database lists, records and/or screen shots that demonstrate compliance information
- Prints, diagrams and/or schematics
- Maintenance records
- Logs (operator, substation, and other types of log)
- Inspection forms
- Mail, memos, or email proving the required information was exchanged, coordinated, submitted or received
- Check-off forms (paper or electronic)
- Any record that demonstrates that the maintenance activity was known, accounted for, and/or performed.

If I replace a failed Protection System component with another component, what testing do I need to perform on the new component?

In order to reset the Table 1 maintenance interval for the replacement component, all relevant Table 1 activities for the component should be performed.

I have evidence to show compliance for PRC-016 (“Special Protection System Misoperation”). Can I also use it to show compliance for this Standard, PRC-005-6?

Maintaining evidence for operation of Remedial Action Schemes could concurrently be utilized as proof of the operation of the associated trip coil (provided one can be certain of the trip coil involved). Thus, the reporting requirements that one may have to do for the Misoperation of a Special Protection Scheme under PRC-016 could work for the activity tracking requirements under this PRC-005-6.

I maintain Disturbance records which show Protection System operations. Can I use these records to show compliance?

These records can be concurrently utilized as dc trip path verifications, to the degree that they demonstrate the proper function of that dc trip path.

I maintain test reports on some of my Protection System components. Can I use these test reports to show that I have verified a maintenance activity?

Yes—the test reports may be used to demonstrate a verified maintenance activity.

References

1. [Protection System Maintenance: A Technical Reference](#). Prepared by the System Protection and Controls Task Force of the NERC Planning Committee. Dated September 13, 2007.
2. "Predicating The Optimum Routine test Interval For Protection Relays," by J. J. Kumm, M.S. Weber, D. Hou, and E. O. Schweitzer, III, IEEE Transactions on Power Delivery, Vol. 10, No. 2, April 1995.
3. "Transmission Relay System Performance Comparison For 2000, 2001, 2002, 2003, 2004 and 2005," Working Group I17 of Power System Relaying Committee of IEEE Power Engineering Society, May 2006.
4. "A Survey of Relaying Test Practices," Special Report by WG I11 of Power System Relaying Committee of IEEE Power Engineering Society, September 16, 1999.
5. "Transmission Protective Relay System Performance Measuring Methodology," Working Group I3 of Power System Relaying Committee of IEEE Power Engineering Society, January 2002.
6. "Processes, Issues, Trends and Quality Control of Relay Settings," Working Group C3 of Power System Relaying Committee of IEEE Power Engineering Society, December 2006.
7. "Proposed Statistical Performance Measures for Microprocessor-Based Transmission-Line Protective Relays, Part I - Explanation of the Statistics, and Part II - Collection and Uses of Data," Working Group D5 of Power System Relaying Committee of IEEE Power Engineering Society, May 1995; Papers 96WM 016-6 PWRD and 96WM 127-1 PWRD, 1996 IEEE Power Engineering Society Winter Meeting.
8. "Analysis And Guidelines For Testing Numerical Protection Schemes," Final Report of CIGRE WG 34.10, August 2000.
9. "Use of Preventative Maintenance and System Performance Data to Optimize Scheduled Maintenance Intervals," H. Anderson, R. Loughlin, and J. Zipp, Georgia Tech Protective Relay Conference, May 1996.
10. "Battery Performance Monitoring by Internal Ohmic Measurements" EPRI Application Guidelines for Stationary Batteries TR- 108826 Final Report, December 1997.
11. "IEEE Recommended Practice for Maintenance, Testing, and Replacement of Valve-Regulated Lead-Acid (VRLA) Batteries for Stationary Applications," IEEE Power Engineering Society Std 1188 – 2005.
12. "IEEE Recommended Practice for Maintenance, Testing, and Replacement of Vented Lead-Acid Batteries for Stationary Applications," IEEE Power & Engineering Society Std 45-2010.
13. "IEEE Recommended Practice for Installation design and Installation of Vented Lead-Acid Batteries for Stationary Applications," IEEE Std 484 – 2002.
14. "Stationary Battery Monitoring by Internal Ohmic Measurements," EPRI Technical Report, 1002925 Final Report, December 2002.
15. "Stationary Battery Guide: Design Application, and Maintenance" EPRI Revision 2 of TR-100248, 1006757, August 2002.

PSMT SDT References

16. "Essentials of Statistics for Business and Economics" Anderson, Sweeney, Williams, 2003
17. "Introduction to Statistics and Data Analysis" - Second Edition, Peck, Olson, Devore, 2005
18. "Statistical Analysis for Business Decisions" Peters, Summers, 1968
19. "Considerations for Maintenance and Testing of Autoreclosing Schemes," NERC System Analysis and Modeling Subcommittee and NERC System Protection and Control Subcommittee, November 2012

Figures

Figure 1: Typical Transmission System

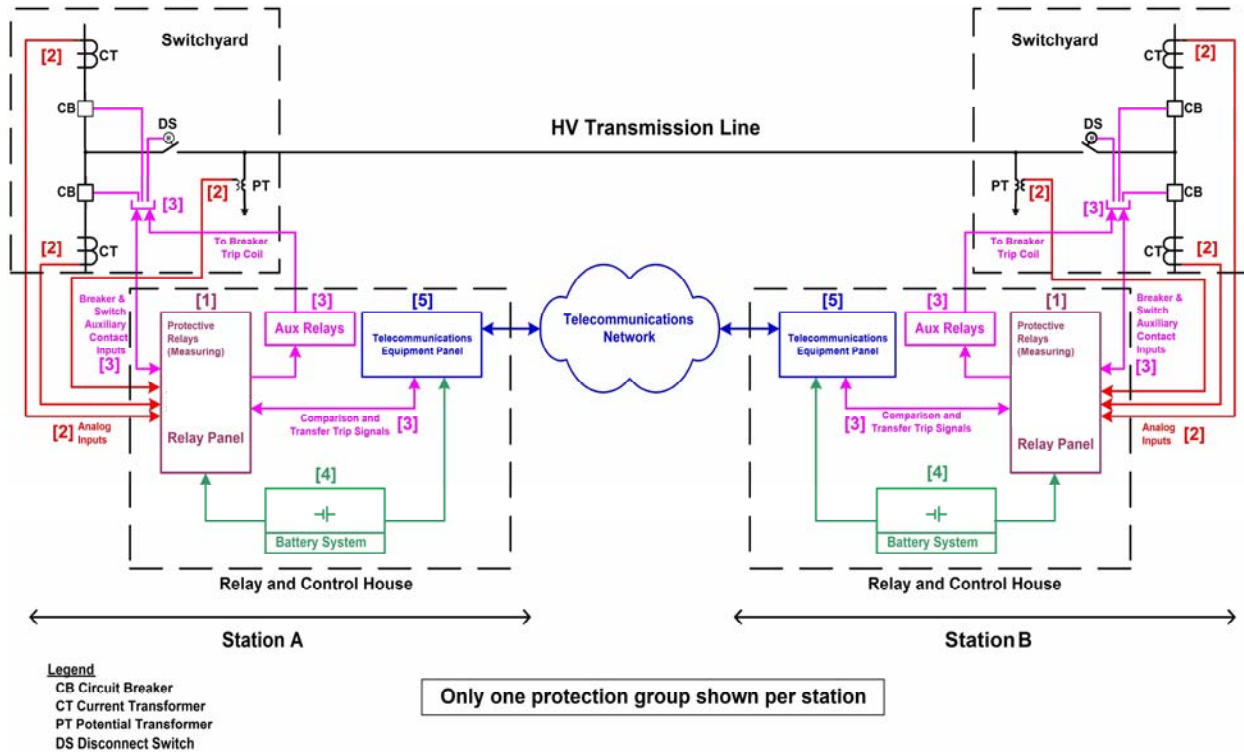

For information on components, see [Figure 1 & 2 Legend – components of Protection Systems](#)

Figure 2: Typical Generation System

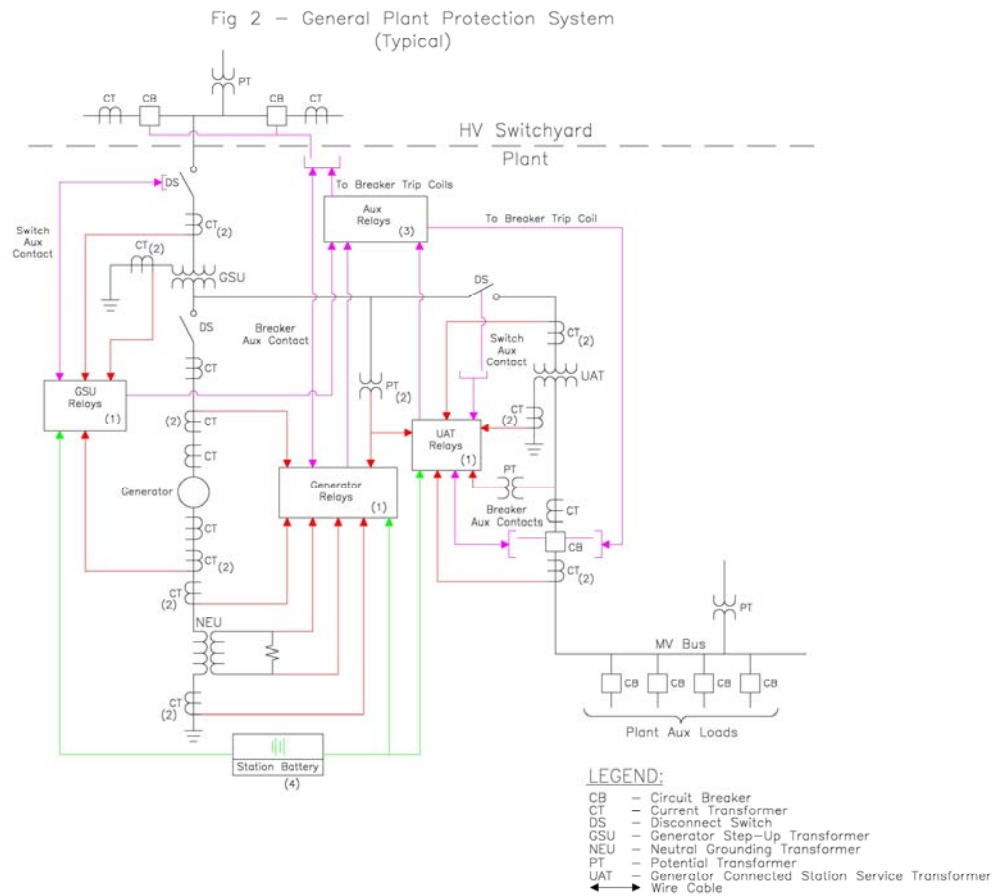

Note: Figure 2 may show elements that are not included within PRC-005-2, and also may not be all-inclusive; see the Applicability section of the standard for specifics.

For information on components, see [Figure 1 & 2 Legend – components of Protection Systems](#)

Figure 1 & 2 Legend – Components of Protection Systems

Number in Figure	Component of Protection System	Includes	Excludes
1	Protective relays which respond to electrical quantities	All protective relays that use current and/or voltage inputs from current & voltage sensors and that trip the 86, 94 or trip coil.	Devices that use non-electrical methods of operation including thermal, pressure, gas accumulation, and vibration. Any ancillary equipment not specified in the definition of Protection Systems. Control and/or monitoring equipment that is not a part of the automatic tripping action of the Protection System
2	Voltage and current sensing devices providing inputs to protective relays	The signals from the voltage & current sensing devices to the protective relay input.	Voltage & current sensing devices that are not a part of the Protection System, including sync-check systems, metering systems and data acquisition systems.
3	Control circuitry associated with protective functions	All control wiring (or other medium for conveying trip signals) associated with the tripping action of 86 devices, 94 devices or trip coils (from all parallel trip paths). This would include fiber-optic systems that carry a trip signal as well as hard-wired systems that carry trip current.	Closing circuits, SCADA circuits, other devices in control scheme not passing trip current
4	Station dc supply	Batteries and battery chargers and any control power system which has the function of supplying power to the protective relays, associated trip circuits and trip coils.	Any power supplies that are not used to power protective relays or their associated trip circuits and trip coils.
5	Communications systems necessary for correct operation of protective functions	Tele-protection equipment used to convey specific information, in the form of analog or digital signals, necessary for the correct operation of protective functions.	Any communications equipment that is not used to convey information necessary for the correct operation of protective functions.

[Additional information can be found in References](#)

effective way to do this is to utilize the relay metered values directly in SCADA, where they can be compared with other references or state estimator values.

5. Breaker status indication from auxiliary contacts is verified in the same way as in (2). Status indications must be consistent with the flow or absence of current.
6. Continuity of the breaker trip circuit from dc bus through the trip coil is monitored by the relay and reported via communications.
7. Correct operation of the on-off carrier channel is also critical to security of the Protection System, so each carrier set has a connected or integrated automatic checkback test unit. The automatic checkback test runs several times a day. Newer carrier sets with integrated checkback testing check for received signal level and report abnormal channel attenuation or noise, even if the problem is not severe enough to completely disable the channel.

These monitoring activities plus the check-back test comprise automatic verification of all the Protection System elements that experience tells us are the most prone to fail. But, does this comprise a complete verification?

Figure A-2

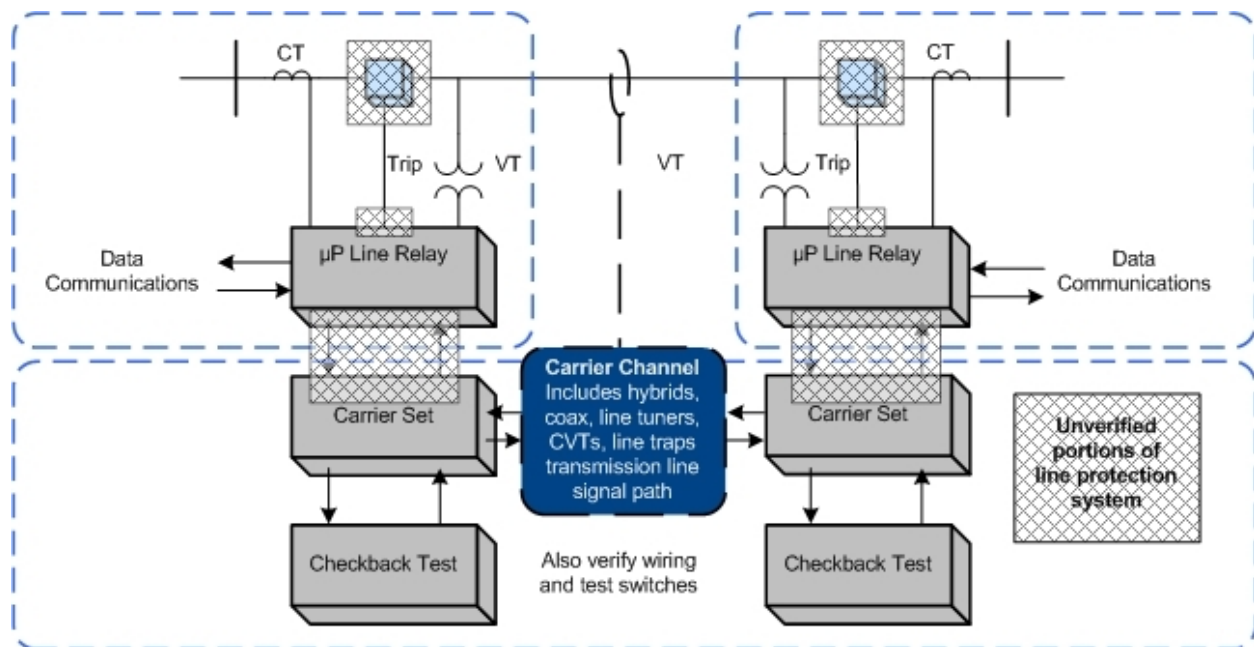

The dotted boxes of Figure A-2 show the sections of verification defined by the monitoring and verification practices just listed. These sections are not completely overlapping, and the shaded regions show elements that are not verified:

1. The continuity of trip coils is verified, but no means is provided for validating the ability of the circuit breaker to trip if the trip coil should be energized.

-
2. Within each line relay, all the microprocessors that participate in the trip decision have been verified by internal monitoring. However, the trip circuit is actually energized by the contacts of a small telephone-type "ice cube" relay within the line protective relay. The microprocessor energizes the coil of this ice cube relay through its output data port and a transistor driver circuit. There is no monitoring of the output port, driver circuit, ice cube relay, or contacts of that relay. These components are critical for tripping the circuit breaker for a Fault.
 3. The check-back test of the carrier channel does not verify the connections between the relaying microprocessor internal decision programs and the carrier transmitter keying circuit or the carrier receiver output state. These connections include microprocessor I/O ports, electronic driver circuits, wiring, and sometimes telephone-type auxiliary relays.
 4. The correct states of breaker and disconnect switch auxiliary contacts are monitored, but this does not confirm that the state change indication is correct when the breaker or switch opens.

A practical solution for (1) and (2) is to observe actual breaker tripping, with a specified maximum time interval between trip tests. Clearing of naturally-occurring Faults are demonstrations of operation that reset the time interval clock for testing of each breaker tripped in this way. If Faults do not occur, manual tripping of the breaker through the relay trip output via data communications to the relay microprocessor meets the requirement for periodic testing.

PRC-005-6 does not address breaker maintenance, and its Protection System test requirements can be met by energizing the trip circuit in a test mode (breaker disconnected) through the relay microprocessor. This can be done via a front-panel button command to the relay logic, or application of a simulated Fault with a relay test set. However, utilities have found that breakers often show problems during Protection System tests. It is recommended that Protection System verification include periodic testing of the actual tripping of connected circuit breakers.

Testing of the relay-carrier set interface in (3) requires that each relay key its transmitter, and that the other relay demonstrate reception of that blocking carrier. This can be observed from relay or DFR records during naturally occurring Faults, or by a manual test. If the checkback test sequence were incorporated in the relay logic, the carrier sets and carrier channel are then included in the overlapping segments monitored by the two relays, and the monitoring gap is completely eliminated.

Appendix B

Protection System Maintenance Standard Drafting Team

Charles W. Rogers
Chairman
Consumers Energy Co.

John B. Anderson
Xcel Energy

Stephen Crutchfield
NERC

Forrest Brock
Western Farmers Electric Cooperative

John Schecter
American Electric Power

Aaron Feathers
Pacific Gas and Electric Company

William D. Shultz
Southern Company Generation

Sam Francis
Oncor Electric Delivery

Scott Vaughan
City of Roseville Electric Department

James M. Kinney
FirstEnergy Corporation

Matthew Westrich
American Transmission Company

Kristina Marriott
ENOSERV

Philip B. Winston
Southern Company Transmission

NERC

NORTH AMERICAN ELECTRIC
RELIABILITY CORPORATION

Supplementary Reference and FAQ

PRC-005-6 Protection System, Automatic
Reclosing, and Sudden Pressure Relaying
Maintenance and Testing

~~October~~ July 2015

RELIABILITY | ACCOUNTABILITY



3353 Peachtree Road NE
Suite 600, North Tower
Atlanta, GA 30326
404-446-2560 | www.nerc.com

Table of Contents

Table of Contents.....	ii
1. Introduction and Summary.....	1
2. Need for Verifying Protection System Performance	332
2.1 Existing NERC Standards for Protection System Maintenance and Testing	332
2.2 Protection System Definition	443
2.3 Applicability of New Protection System Maintenance Standards	443
2.3.1 Frequently Asked Questions:	554
2.4.1 Frequently Asked Questions:	776
3. Protection System and Automatic Reclosing Product Generations	14149
4. Definitions.....	161611
4.1 Frequently Asked Questions:	171712
5. Time-Based Maintenance (TBM) Programs.....	191914
5.1 Maintenance Practices.....	191914
5.1.1 Frequently Asked Questions:	212116
5.2 Extending Time-Based Maintenance	222217
5.2.1 Frequently Asked Questions:	232318
6. Condition-Based Maintenance (CBM) Programs.....	242419
6.1 Frequently Asked Questions:	242419
7. Time-Based Versus Condition-Based Maintenance.....	262621
7.1 Frequently Asked Questions:	262621
8. Maximum Allowable Verification Intervals.....	323227
8.1 Maintenance Tests.....	323227
8.1.1 Table of Maximum Allowable Verification Intervals.....	323227

8.1.2 Additional Notes for Tables 1-1 through 1-5, Table 3, and Table 4.....	343429
8.1.3 Frequently Asked Questions:	353530
8.2 Retention of Records.....	404035
8.2.1 Frequently Asked Questions:	414135
8.3 Basis for Table 1 Intervals	434337
8.4 Basis for Extended Maintenance Intervals for Microprocessor Relays	444438
9. Performance-Based Maintenance Process.....	464641
9.1 Minimum Sample Size.....	474742
9.2 Frequently Asked Questions:	505044
10. Overlapping the Verification of Sections of the Protection System.....	616155
10.1 Frequently Asked Questions:	616155
11. Monitoring by Analysis of Fault Records	626256
11.1 Frequently Asked Questions:	636357
12. Importance of Relay Settings in Maintenance Programs	646458
12.1 Frequently Asked Questions:	646458
13. Self-Monitoring Capabilities and Limitations.....	676761
13.1 Frequently Asked Questions:	686862
14. Notification of Protection System or Automatic Reclosing Failures.....	696963
15. Maintenance Activities	707064
15.1 Protective Relays (Table 1-1)	707064
15.1.1 Frequently Asked Questions:	707064
15.2 Voltage & Current Sensing Devices (Table 1-3)	707064
15.2.1 Frequently Asked Questions:	727266
15.3 Control circuitry associated with protective functions (Table 1-5)	737367
15.3.1 Frequently Asked Questions:	747469

15.4 Batteries and DC Supplies (Table 1-4).....	767671
15.4.1 Frequently Asked Questions:	777771
15.5 Associated communications equipment (Table 1-2)	919186
15.5.1 Frequently Asked Questions:	929287
15.6 Alarms (Table 2)	959590
15.6.1 Frequently Asked Questions:	969690
15.7 Distributed UFLS and Distributed UVLS Systems (Table 3).....	969691
15.7.1 Frequently Asked Questions:	979791
15.8 Automatic Reclosing (Table 4)	979792
15.8.1 Frequently-asked Questions	989892
15.9 Examples of Evidence of Compliance	10010094
15.9.1 Frequently Asked Questions:	10210294
References	10310395
Figures.....	10510597
Figure 1: Typical Transmission System.....	10510597
Figure 2: Typical Generation System	10610698
Figure 1 & 2 Legend – Components of Protection Systems	10710799
Appendix A.....	108108100
Appendix B	111111103
Protection System Maintenance Standard Drafting Team.....	111111103

1. Introduction and Summary

Note: This supplementary reference for PRC-005-6 is neither mandatory nor enforceable.

NERC currently has four Reliability Standards that are mandatory and enforceable within the jurisdiction of the ERO and address various aspects of maintenance and testing of Protection and Control Systems.

These standards are:

PRC-005-1.1b — Transmission and Generation Protection System Maintenance and Testing

PRC-008-0 — Underfrequency Load Shedding Equipment Maintenance Programs

PRC-011-0 — UVLS System Maintenance and Testing

PRC-017-0 — Special Protection System Maintenance and Testing

While these standards require that applicable entities have a maintenance program for Protection Systems, and that these entities must be able to demonstrate they are carrying out such a program, there are no specifics regarding the technical requirements for Protection System maintenance programs. Furthermore, FERC Order 693¹ directed additional modifications to the respective Protection System maintenance programs. PRC-005-3 will replace PRC-005-2 which combined and replaced PRC-005, PRC-008, PRC-011 and PRC-017. PRC-005-3 adds Automatic Reclosing to PRC-005-2. PRC-005-2 addressed these directed modifications and replaces PRC-005, PRC-008, PRC-011 and PRC-017.

FERC Order 758² further directed that maintenance of reclosing relays and sudden pressure relays that affect the reliable operation of the Bulk Power System be addressed. PRC-005-3 addresses this directive regarding reclosing relays, and, when approved, will supersede PRC-005-2. PRC-005-4 addresses this directive regarding sudden pressure relays and, when approved, will supersede PRC-005-3.

This document augments the Supplementary Reference and FAQ previously developed for PRC-005-4² by including discussions relevant to the following standard revisions:

- PRC-005-3 — revision to add Automatic Reclosing in accordance with directives in FERC Order 758 as supported by the technical reports of the System Protection Control Subcommittee and the System Analysis and Modeling Subcommittee~~Reclosing added in PRC 005-3~~
- PRC-005-4 — revision to add and Sudden Pressure Relaying in accordance with directives in FERC Order 758 as supported by the technical report of the System Protection Control Subcommittee~~in PRC 005-4~~

¹ Mandatory Reliability Standards for the Bulk-Power System, Order No. 693, 118 FERC ¶ 61,218, FERC Stats. & Regs. ¶ 31,242 (“Order No. 693”), order on reh’g, Mandatory Reliability Standards for the Bulk-Power System, 120 FERC ¶ 61,053 (Order No. 693-A) (2007).

² Interpretation of Protection System Reliability Standard, Order No. 758, 138 FERC ¶ 61,094 (2012) (“Order No. 758”).

-
- PRC-005-5 ~~—revision~~ updating Applicability requirements for dispersed generation resources to align with revisions to the definition of the Bulk Electric System
 - PRC-005-6 ~~—revision to~~ add supervisory relays to Automatic Reclosing in accordance with directives in FERC Order 803³.

³ Protection System Maintenance Reliability Standard, Order No. 803, 150 FERC ¶ 61,039 (2015) (“Order No. 803”).

2. Need for Verifying Protection System Performance

Protective relays have been described as silent sentinels, and do not generally demonstrate their performance until a Fault or other power system problem requires that they operate to protect power system Elements, or even the entire Bulk Electric System (BES). Lacking Faults, switching operations or system problems, the Protection Systems may not operate, beyond static operation, for extended periods. A Misoperation— defined as --a false operation of a Protection System or a failure of the Protection System to operate, as designed, when needed--can result in equipment damage, personnel hazards, and wide-area Disturbances or unnecessary customer outages. Maintenance or testing programs are used to determine the performance and availability of Protection Systems.

Typically, utilities have tested Protection Systems at fixed time intervals, unless they had some incidental evidence that a particular Protection System was not behaving as expected. Testing practices vary widely across the industry. Testing has included system functionality, calibration of measuring devices, and correctness of settings. Typically, a Protection System must be visited at its installation site and, in many cases, removed from service for this testing.

Fundamentally, a Reliability Standard for Protection System Maintenance and Testing requires the performance of the maintenance activities that are necessary to detect and correct plausible age and service related degradation of the Protection System components, such that a properly built and commissioned Protection System will continue to function as designed over its service life.

Similarly station batteries, which are an important part of the station dc supply, are not called upon to provide instantaneous dc power to the Protection System until power is required by the Protection System to operate circuit breakers or interrupting devices to clear Faults or to isolate equipment.

2.1 Existing NERC Standards for Protection System Maintenance and Testing

For critical BES protection functions, NERC standards have required that each utility or asset owner define a testing program. The starting point is the [existing Board approved](#) Standard PRC-005-5, briefly restated as follows:

Purpose: To document and implement programs for the maintenance of all Protection Systems affecting the reliability of the Bulk Electric System (BES) so that these Protection Systems are kept in working order.

PRC-005-6 is not specific on where the boundaries of the Protection Systems lie. However, the definition of Protection System in the [Glossary of Terms](#) Used in NERC Reliability Standards (Glossary) indicates what must be included as a minimum.

At the beginning of the project to develop PRC-005-2, the definition of Protection System was:

Protective relays, associated communications Systems, voltage and current sensing devices, station batteries and dc control circuitry.

Applicability: Owners of generation and transmission Protection Systems.

Requirements: The owner shall have a documented maintenance program with test intervals. The owner must keep records showing that the maintenance was performed at the specified intervals.

2.2 Protection System Definition

The most recently approved definition of Protection Systems is:

- Protective relays which respond to electrical quantities,
- Communications systems necessary for correct operation of protective functions,
- Voltage and current sensing devices providing inputs to protective relays,
- Station dc supply associated with protective functions (including station batteries, battery chargers, and non-battery-based dc supply), and
- Control circuitry associated with protective functions through the trip coil(s) of the circuit breakers or other interrupting devices.

2.3 Applicability of New Protection System Maintenance Standards

The BES purpose is to transfer bulk power. The applicability language has been changed from the original PRC-005:

“...affecting the reliability of the Bulk Electric System (BES)...”

To the present language:

“...that are installed for the purpose of detecting Faults on BES Elements (lines, buses, transformers, etc.).”

The drafting team intends that this standard will be consistent with any future definition of the Bulk Electric System. There should be no ambiguity; if the Element is a BES Element, then the Protection System protecting that Element should then be included within this standard. If there is regional variation to the definition, then there will be a corresponding regional variation to the Protection Systems that fall under this standard.

There is no way for the Standard Drafting Team to know whether a specific 230KV line, 115KV line (even 69KV line), for example, should be included or excluded. Therefore, the team expressed the clear intent that the standard language should simply be applicable to Protection Systems for BES Elements.

The BES is a NERC defined term that, from time to time, may undergo revisions. Additionally, there may be regional variations that are allowed in the present and future definitions.⁴ Refer to the applicable Regional Reliability Organization for any applicable allowed variations.

While this standard may undergo revisions in the future, this standard will not attempt to keep up with revisions to the NERC definition of BES, but, rather, simply make BES Protection Systems applicable.

The Standard is applied to Generator Owners (GO) and Transmission Owners (TO) because GOs and TOs have BES equipment. The standard brings in Distribution Providers (DP) because,

⁴ See the NERC Glossary of Terms for the present, in-force definition.

depending on the station configuration of a particular substation, there may be Protection System equipment installed at a non-transmission voltage level (Distribution Provider equipment) that is wholly or partially installed to protect the BES. PRC-005-~~24~~ would apply to this equipment. An example is underfrequency load-shedding, which is frequently applied in distribution systems to meet PRC-007-0.

PRC-005-2 replaced the existing PRC-005, PRC-008, PRC-011 and PRC-017. Much of the original language of those standards was carried forward whenever it was possible to continue the intent and avoid a conflict with FERC Order 693. For example, the original PRC-008 was constructed quite differently than the original PRC-005. The drafting team agrees with the intent of this and notes that distributed tripping schemes would have to exhibit multiple failures to trip before they would prove to be significant, as opposed to a single failure to trip of, for example, a transmission Protection System Bus Differential lock-out relay. While a substantial number of failures of these distribution breakers could be significant, the team concluded likely that distribution breakers are operated often only for Fault clearing duty; and, therefore, the distribution circuit breakers are operated at least as frequently as stipulated in any requirement in this standard.

Additionally, since PRC-005-2 replaced PRC-011, it will be important to distinguish between under-voltage Protection Systems that protect individual Loads and Protection Systems that are Undervoltage Load Shedding (UVLS) schemes that protect the BES. Any UVLS scheme that had been applicable under PRC-011 is now applicable under PRC-005-2. An example of an under-voltage load-shedding scheme that is not applicable to this standard is one in which the tripping action was intended to prevent low distribution voltage to a specific Load from a Transmission system that was intact except for the line that was out of service, as opposed to preventing a Cascading outage or Transmission system collapse.

It had been correctly noted that the devices needed for PRC-011 are the very same types of devices needed in PRC-005.

Thus, a standard written for Protection Systems of the BES can easily make the needed requirements for Protection Systems, and replace some other standards at the same time.

2.3.1 Frequently Asked Questions:

What exactly is the BES, or Bulk Electric System?

BES is the abbreviation for the defined term Bulk Electric System. BES is a term in the Glossary of Terms used in Reliability Standards, and is not being modified within this draft standard.

Why is Distribution Provider included within the Applicable Entities and as a responsible entity within several of the requirements? Wouldn't anyone having relevant Facilities be a Transmission Owner?

Depending on the station configuration of a particular substation, there may be Protection System equipment installed at a non-transmission voltage level (Distribution Provider equipment) that is wholly or partially installed to protect the BES. PRC-005-~~24~~ applies to this equipment. An example is underfrequency load-shedding, which is frequently applied well down into the distribution system to meet the requirements of PRC-007-0.

We have an under voltage load-shedding (UVLS) system in place that prevents one of our distribution substations from supplying extremely low voltage in the case of a

specific transmission line outage. The transmission line is part of the BES. Does this mean that our UVLS system falls within this standard?

The situation, as stated, indicates that the tripping action was intended to prevent low distribution voltage to a specific Load from a Transmission System that was intact, except for the line that was out of service, as opposed to preventing Cascading outage or Transmission System Collapse. This standard is not applicable to this UVLS.

We have a UFLS or UVLS scheme that sheds the necessary Load through distribution-side circuit breakers and circuit reclosers. Do the trip-test requirements for circuit breakers apply to our situation?

No--Distributed tripping schemes would have to exhibit multiple failures to trip before they would prove to be significant, as opposed to a single failure to trip of, for example, a transmission Protection System bus differential lock-out relay. While many failures of these distribution breakers could add up to be significant, it is also believed that distribution breakers are operated often on just Fault clearing duty; and, therefore, the distribution circuit breakers are operated at least as frequently as any requirements that might have appeared in this standard.

We have a UFLS scheme that, in some locales, sheds the necessary Load through non-BES circuit breakers and, occasionally, even circuit switchers. Do the trip-test requirements for circuit breakers apply to our situation?

If your “non-BES circuit breaker” has been brought into this standard by the inclusion of UFLS requirements, and otherwise would not have been brought into this standard, then the answer is that there are no trip-test requirements. For these devices that are otherwise non-BES assets, these tripping schemes would have to exhibit multiple failures to trip before they would prove to be as significant as, for example, a single failure to trip of a transmission Protection System bus differential lock-out relay.

How does the “Facilities” section of “Applicability” track with the standards that will be retired once PRC-005-2 becomes effective?

In establishing PRC-005-2, the drafting team combined legacy standards PRC-005-1b, PRC-008-0, PRC-011-0, and PRC-017-0. The merger of the subject matter of these standards is reflected in Applicability 4.2.

The intent of the drafting team is that the legacy standards be reflected in PRC-005-2 as follows:

- Applicability of PRC-005-1.1b for Protection Systems relating to non-generator elements of the BES is addressed in 4.2.1;
- Applicability of PRC-008-0 for underfrequency load shedding systems is addressed in 4.2.2;
- Applicability of PRC-011-0 for undervoltage load shedding relays is addressed in 4.2.3;
- Applicability of PRC-017-0 for Remedial Action Schemes is addressed in 4.2.4;
- Applicability of PRC-005-1.1b for Protection Systems for BES generators is addressed in 4.2.5 and 4.2.6.

2.4 Applicable Relays

The Glossary definition has a Protection System including relays, dc supply, current and voltage sensing devices, dc control circuitry and associated communications circuits. The relays to which this standard applies are those protective relays that respond to electrical quantities and provide a trip output to trip coils, dc control circuitry or associated communications equipment. This definition extends to IEEE Device No. 86 (lockout relay) and IEEE Device No. 94 (tripping or trip-free relay), as these devices are tripping relays that respond to the trip signal of the protective relay that processed the signals from the current and voltage-sensing devices.

Relays that respond to non-electrical inputs or impulses (such as, but not limited to, vibration, seismic, thermal or gas accumulation) are not included.

Automatic Reclosing is addressed in PRC-005-3 by explicitly addressing them outside the definition of Protection System. The specific locations for applicable Automatic Reclosing are addressed in Applicability Section 4.2.7.

Sudden Pressure Relaying is addressed in PRC-005-4 by explicitly addressing them outside the definition of Protection System. The specific locations for applicable Sudden Pressure Relaying are addressed in Applicability Section 4.2.1, 4.2.5.2, 4.2.5.3, and 4.2.6.

2.4.1 Frequently Asked Questions:

Are power circuit reclosers, reclosing relays, closing circuits and auto-restoration schemes covered in this Standard?

Yes. Automatic Reclosing includes reclosing relays and the associated dc control circuitry. Section 4.2.7 of the Applicability specifically limits the applicable reclosing relays to:

4.2.7 Automatic Reclosing

4.2.7.1 Automatic Reclosing applied on the terminals of Elements connected to the BES bus located at generating plant substations where the total installed gross generating plant capacity is greater than the gross capacity of the largest BES generating unit within the Balancing Authority Area or, if a member of a Reserve Sharing Group, the largest generating unit within the Reserve Sharing Group.

4.2.7.2 Automatic Reclosing applied on the terminals of all BES Elements at substations one bus away from generating plants specified in Section 4.2.7.1 when the substation is less than 10 circuit-miles from the generating plant substation.

4.2.7.3 Automatic Reclosing applied as an integral part of an RAS specified in Section 4.2.4.

Further, Footnote 1 to Applicability Section 4.2.7 establishes that Automatic Reclosing addressed in 4.2.7.1 and 4.2.7.2 may be excluded if the equipment owner can demonstrate that a close-in three-phase fault present for twice the normal clearing time (capturing a minimum trip-close-trip time delay) does not result in a total loss of gross generation in the Interconnection exceeding the gross capacity of the largest relevant BES generating unit where the Automatic Reclosing is applied.

Additionally, Footnote 2 to Applicability Section 4.2.7.1 advises that the entity's PSMP needs to remain current regarding the applicability of Automatic Reclosing Components relative to the largest generating unit within the Balancing Authority Area or Reserve Sharing Group.

The Applicability as detailed above was recommended by the NERC System Analysis and Modeling Subcommittee (SAMS) after a lengthy review of the use of reclosing within the BES. SAMS concluded that automatic reclosing is largely implemented throughout the BES as an operating convenience, and that automatic reclosing mal-performance affects BES reliability only when the reclosing is part of a Remedial Action Schemes, or when premature autoreclosing has the potential to cause generating unit or plant instability. A technical report, "Considerations for Maintenance and Testing of Autoreclosing Schemes — November 2012", is referenced in PRC-005-3 and provides a more detailed discussion of these concerns.

Why did the standard drafting team not include IEEE device numbers to describe Automatic Reclosing Relays?

The drafting team elected not to include IEEE device numbers to describe Automatic Reclosing because Automatic Reclosing component type could be a stand-alone electromechanical relay; or could be the 79 function within a microprocessor based multi-function relay.

Was it the drafting team's intent that the definition of Automatic Reclosing should incorporate all closings that happen automatically, or just Automatic Reclosing relays?

The drafting team believes that Automatic Reclosing definition, as supported by the second part of the IEEE Standard 100 definition stating "Automatic reclosing equipment - Automatic equipment that provides for reclosing a switching device as desired after it has opened automatically under abnormal conditions..." adequately addresses this concern. Automatic Reclosing does not include actions such as automatic closing of the circuit breakers associated with shunt or series capacitor banks or shunt reactors.

What is synchronizing or synchronism check relay (Sync-Check - 25)?

A synchronizing device that produces an output that supervises closure of a circuit breaker between two circuits whose voltages are within prescribed limits of magnitude and within the prescribed phase angle for the prescribed time. It may or may not include voltage or speed control. A sync-check relay permits the paralleling of two circuits that are within prescribed (usually wider) limits of voltage magnitude and phase angle for the prescribed time.

How do I interpret Applicability Section 4.2.7 to determine applicability in the following examples:

At my generating plant substation, I have a total of 800 MW connected to one voltage level and 200 MW connected to another voltage level. How do I determine my gross capacity? Where do I consider Automatic Reclosing to be applicable?

Scenario number 1:

The 800 MW of generation is connected to a BES voltage level bus, the 200 MW is connected to a non-BES voltage level bus, and there is no connection between the two buses locally or within 10 circuit miles from the generating plant substation. The largest single unit in the BA area is 750 MW.

In this case, the total installed gross generating capacity would be 800 MW. The two units are essentially independent plants.

The BES voltage level bus is considered to be the bus to which the 800 MW of generation is connected. Any BES Automatic Reclosing at this location, as well as other locations within 10 circuit miles, is considered to be applicable because 800 MW exceeds the largest single unit in the BA area.

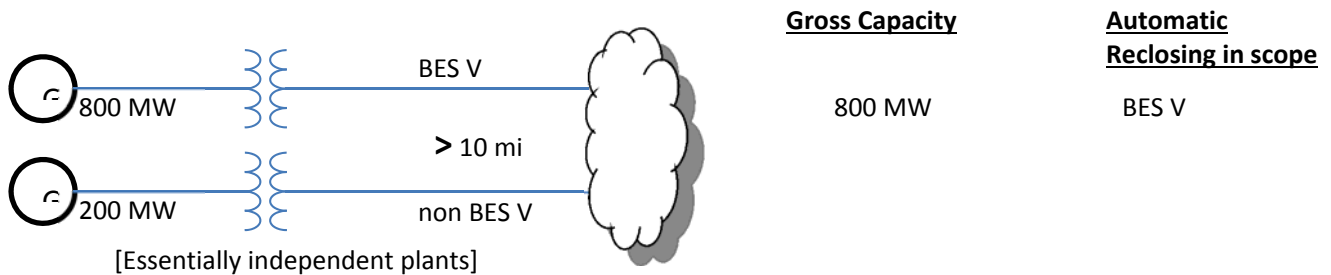

Scenario number 2:

The 800 MW of generation is connected to a BES voltage level bus, the 200 MW unit is connected to a non-BES voltage level bus, and there is a connection between the two buses locally or within 10 circuit miles from the generating plant substation. The largest single unit in the BA area is 750 MW.

In this case, reclosing into a fault on the BES system could impact the stability of the non-BES-connected generating units. Therefore, the total installed gross generating capacity would be 1000 MW.

The BES voltage level bus is considered to be the bus to which the 800 MW of generation is connected. Any BES Automatic Reclosing at this location, as well as other locations within 10 circuit miles, is considered to be applicable because total of 1000 MW exceeds the largest single

unit in the BA area. However, the Automatic Reclosing on the non-BES voltage level bus is not applicable.

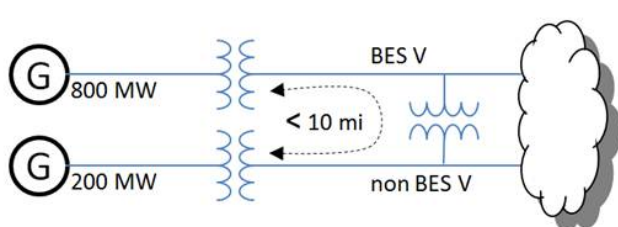

Gross Capacity

1000 MW

Automatic Reclosing in scope

BES V

Scenario number 3:

The 800 MW of generation is connected to a BES voltage level bus, the 200 MW unit is connected to a non-BES voltage level bus, and there is no connection between the two buses locally or within 10 circuit miles from the generating plant substation but the generating units connected at the BES voltage level do not operate independently of the units connected at the non BES voltage level (e.g., a combined cycle facility where 800 MW of combustion turbines are connected at a BES voltage level whose exhaust is used to power a 200 MW steam unit connected to a non BES voltage level. The largest single unit in the BA area is 750 MW.

In this case, the total installed gross generating capacity would be 1000 MW. Therefore, reclosing into a fault on the BES voltage level would result in a loss of the 800 MW combustion turbines and subsequently result in the loss of the 200 MW steam unit because of the loss of the heat source to its boiler.

The BES voltage level bus is considered to be the bus to which the 800 MW of generation is connected. Any BES Automatic Reclosing at this location, as well as other locations within 10 circuit miles, is considered to be applicable because total of 1000 MW exceeds the largest single unit in the BA area. However, the Automatic Reclosing on the non-BES voltage level bus is not applicable.

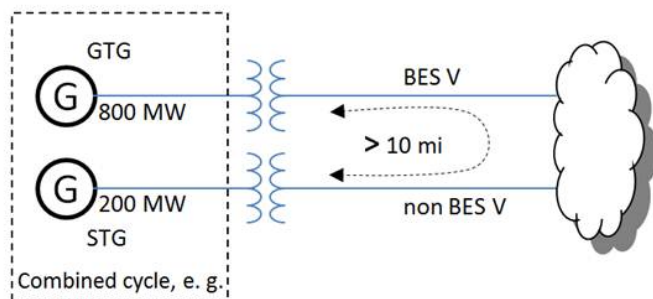

Gross Capacity

1000 MW

Automatic Reclosing in scope

BES V

Scenario 4

The 800 MW of generation is connected at 345 kV and the 200 MW is connected at 138 kV with an autotransformer at the generating plant substation connecting the two voltage levels. The largest single unit in the BA area is 900 MW.

In this case, the total installed gross generating capacity would be 1000 MW and section 4.2.7.1 would be applicable to both the 345 kV Automatic Reclosing Components and the 138 kV Automatic Reclosing Components, since the total capacity of 1000 MW is larger than the largest single unit in the BA area.

However, if the 345 kV and the 138 kV systems can be shown to be uncoupled such that the 138 kV reclosing relays will not affect the stability of the 345 kV generating units then the 138 kV Automatic Reclosing Components need not be included per section 4.2.7.1.

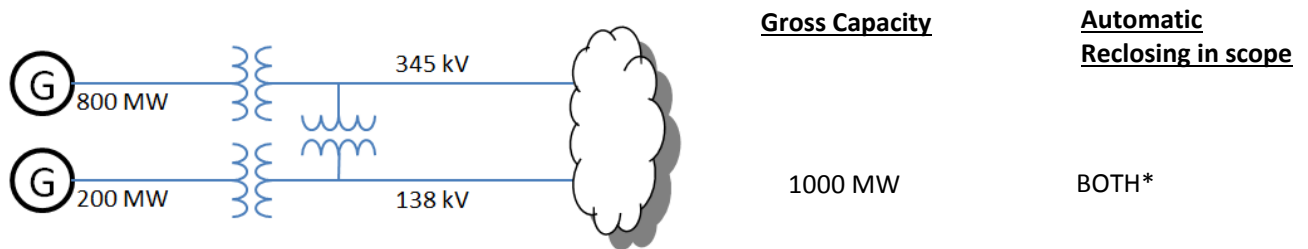

* The study detailed in Footnote 1 of the draft standard may eliminate the 138 kV Automatic Reclosing Components and/or the 345 kV Automatic Reclosing Components

Why does 4.2.7.2 specify “10 circuit miles”?

As noted in “Considerations for Maintenance and Testing of Autoreclosing Schemes — November 2012,” transmission line impedance on the order of one mile away typically provides adequate impedance to prevent generating unit instability and a 10 mile threshold provides sufficient margin.

Should I use MVA or MW when determining the installed gross generating plant capacity?

Be consistent with the rating used by the Balancing Authority for the largest BES generating unit within their area.

What value should we use for generating plant capacity in 4.2.7.1?

Use the value reported to the Balance Authority for generating plant capacity for planning and modeling purposes. This can be nameplate or other values based on generating plant limitations such as boiler or turbine ratings.

What is considered to be “one bus away” from the generation?

The BES voltage level bus is considered to be the generating plant substation bus to which the generator step-up transformer is connected. “One bus away” is the next bus, connected by either a transmission line or transformer.

I use my protective relays only as sources of metered quantities and breaker status for SCADA and EMS through a substation distributed RTU or data concentrator to the control center. What are the maintenance requirements for the relays?

This standard addresses Protection Systems that are installed for the purpose of detecting Faults on BES Elements (e.g. lines, buses, transformers, etc.). Protective relays, providing only the functions mentioned in the question, are not included.

Are Reverse Power Relays installed on the low-voltage side of distribution banks considered to be components of “Protection Systems that are installed for the purpose of detecting Faults on BES Elements (i.e. lines, buses, transformers, etc.)?”

Reverse power relays are often installed to detect situations where the transmission source becomes de-energized and the distribution bank remains energized from a source on the low-voltage side of the transformer and the settings are calculated based on the charging current of the transformer from the low-voltage side. Although these relays may operate as a result of a fault on a BES element, they are not “installed for the purpose of detecting” these faults.

Why is the maintenance of Sudden Pressure Relaying being addressed in PRC-005-6?

Proper performance of Sudden Pressure Relaying supports the reliability of the BES because fault pressure relays can detect rapid changes in gas pressure, oil pressure, or oil flow that are indicative of faults within liquid-filled, wire-wound equipment such as turn-to-turn faults which may be undetected by Protection Systems. Additionally, Sudden Pressure Relaying can quickly detect faults and operate to limit damage to liquid-filled, wire-wound equipment.

What type of devices are classified as fault pressure relay?

There are three main types of fault pressure relays; rapid gas pressure rise, rapid oil pressure rise, and rapid oil flow devices.

Rapid gas pressure devices monitor the pressure in the space above the oil (or other liquid), and initiate tripping action for a rapid rise in gas pressure resulting from the rapid expansion of the liquid caused by a fault. The sensor is located in the gas space.

Rapid oil pressure devices monitor the pressure in the oil (or other liquid), and initiate tripping action for a rapid pressure rise caused by a fault. The sensor is located in the liquid.

Rapid oil flow devices, Buchholz) monitor the liquid flow between a transformer/reactor and its conservator. Normal liquid flow occurs continuously with ambient temperature changes and with internal heating from loading and does not operate the rapid oil flow device. However, when an internal arc occurs, a sudden expansion of liquid can be monitored as rapid liquid flow from the transformer into the conservator resulting in actuation of the rapid oil flow device.

Are sudden pressure relays that only initiate an alarm included in the scope of PRC-005-6?

No--the definition of Sudden Pressure Relaying specifies only those that trip an interrupting device(s) to isolate the equipment it is monitoring.

Are pressure relief devices included in the scope of PRC-005-6?

No--PRDs are not included in the Sudden Pressure Relaying definition.

Is Sudden Pressure Relaying installed on distribution transformers included in PRC-005-6?

No--Applicability 4.2.1, 4.2.5, and 4.2.6 explicitly describes what Sudden Pressure Relaying is included within the standard.

Are non-electrical sensing devices (other than fault pressure relays) such as low oil level or high winding temperatures included in PRC-005-6?

No--based on the SPCS technical document, "Sudden Pressure Relays and Other Devices that Respond to Non-Electrical Quantities – December 2013," the only applicable non-electrical sensing devices are Sudden Pressure Relays.

The standard specifically mentions auxiliary and lock-out relays. What is an auxiliary tripping relay?

An auxiliary relay, IEEE Device No. 94, is described in IEEE Standard C37.2-2008 as: "A device that functions to trip a circuit breaker, contactor, or equipment; to permit immediate tripping by other devices; or to prevent immediate reclosing of a circuit interrupter if it should open automatically, even though its closing circuit is maintained closed."

What is a lock-out relay?

A lock-out relay, IEEE Device No. 86, is described in IEEE Standard C37.2 as: "A device that trips and maintains the associated equipment or devices inoperative until it is reset by an operator, either locally or remotely."

3. Protection System and Automatic Reclosing Product Generations

The likelihood of failure and the ability to observe the operational state of a critical Protection System and Automatic Reclosing both depend on the technological generation of the relays, as well as how long they have been in service. Unlike many other transmission asset groups, protection and control systems have seen dramatic technological changes spanning several generations. During the past 20 years, major functional advances are primarily due to the introduction of microprocessor technology for power system devices, such as primary measuring relays, monitoring devices, control systems, and telecommunications equipment.

Modern microprocessor-based relays have six significant traits that impact a maintenance strategy:

- Self-monitoring capability - the processors can check themselves, peripheral circuits, and some connected substation inputs and outputs, such as trip coil continuity. Most relay users are aware that these relays have self-monitoring, but are not focused on exactly what internal functions are actually being monitored. As explained further below, every element critical to the Protection System must be monitored, or else verified periodically.
- Ability to capture Fault records showing how the Protection System responded to a Fault in its zone of protection, or to a nearby Fault for which it is required not to operate.
- Ability to meter currents and voltages, as well as status of connected circuit breakers, continuously during non-Fault times. The relays can compute values, such as MW and ~~MVAR~~ Mvar line flows, that are sometimes used for operational purposes, such as SCADA.
- Data communications via ports that provide remote access to all of the results of Protection System monitoring, recording and measurement.
- Ability to trip or close circuit breakers and switches through the Protection System outputs, on command from remote data communications messages, or from relay front panel button requests.
- Construction from electronic components, some of which have shorter technical life or service life than electromechanical components of prior Protection System generations.

There have been significant advances in the technology behind the other components of Protection Systems. Microprocessors are now a part of battery chargers, associated communications equipment, voltage and current-measuring devices, and even the control circuitry (in the form of software-latches replacing lock-out relays, etc.).

Any Protection System component can have self-monitoring and alarming capability, not just relays. Because of this technology, extended time intervals for maintenance and inspection can find their way into all components of the Protection System.

This standard also recognizes the distinct advantage of using advanced technology to justifiably defer or even eliminate traditional maintenance. Just as a hand-held calculator does not require routine testing and calibration, neither does a calculation buried in a microprocessor-based

device that results in a “lock-out.” Thus, the software-latch 86 that replaces an electro-mechanical 86 does not require routine trip testing. Any trip circuitry associated with the “soft 86” would still need applicable verification activities performed, but the actual “86” does not have to be “electrically operated” or even toggled.

4. Definitions

Protection System Maintenance Program (PSMP) — An ongoing program by which Protection System, Automatic Reclosing and Sudden Pressure Relaying Components are kept in working order and proper operation of malfunctioning Components is restored. A maintenance program for a specific Component includes one or more of the following activities:

- Verify — Determine that the Component is functioning correctly.
- Monitor — Observe the routine in-service operation of the Component.
- Test — Apply signals to a Component to observe functional performance or output behavior, or to diagnose problems.
- Inspect — Examine for signs of Component failure, reduced performance and degradation.
- Calibrate — Adjust the operating threshold or measurement accuracy of a measuring element to meet the intended performance requirement.

Automatic Reclosing – Includes the following Components:

- Reclosing relay
- Supervisory relay(s) or function(s) – relay(s) or function(s) that perform voltage and/or sync check functions that enables or disables operation of the reclosing relay
- Voltage sensing devices associated with the supervisory relay(s) or function(s)
- Control circuitry associated with the reclosing relay or supervisory relay(s) or function(s)

Sudden Pressure Relaying – A system that trips an interrupting device(s) to isolate the equipment it is monitoring and includes the following Components:

- Fault pressure relay – a mechanical relay or device that detects rapid changes in gas pressure, oil pressure, or oil flow that are indicative of faults within liquid-filled, wire-wound equipment
- Control circuitry associated with a fault pressure relay

Unresolved Maintenance Issue – A deficiency identified during a maintenance activity that causes the component to not meet the intended performance, cannot be corrected during the maintenance interval, and requires follow-up corrective action.

Segment – Components of a consistent design standard, or a particular model or type from a single manufacturer that typically share other common elements. Consistent performance is expected across the entire population of a Segment. A Segment must contain at least sixty (60) individual Components.

Component Type –

- Any one of the five specific elements of a Protection System.
- Any one of the ~~four~~^{two} specific elements of Automatic Reclosing.
- Any one of the two specific elements of Sudden Pressure Relaying.

Component – Any individual discrete piece of equipment included in a Protection System, Automatic Reclosing, or Sudden Pressure Relaying.

Countable Event – A failure of a Component requiring repair or replacement, any condition discovered during the maintenance activities in Tables 1-1 through 1-5, Table 3, Tables 4-1 through 4-3, and Table 5, which requires corrective action or a Protection System Misoperation attributed to hardware failure or calibration failure. Misoperations due to product design errors, software errors, relay settings different from specified settings, Protection System Component, Automatic Reclosing or Sudden Pressure Relaying configuration or application errors are not included in Countable Events.

4.1 Frequently Asked Questions:

Why does PRC-005-6 not specifically require maintenance and testing procedures, as reflected in the previous standard, PRC-005-1?

PRC-005-1 does not require detailed maintenance and testing procedures, but instead requires summaries of such procedures, and is not clear on what is actually required. PRC-005-6 requires a documented maintenance program, and is focused on establishing requirements rather than prescribing methodology to meet those requirements. Between the activities identified in the Tables 1-1 through 1-5, Table 2, Table 3, and Table 4 (collectively the “Tables”), and the various components of the definition established for a “Protection System Maintenance Program,” PRC-005-6 establishes the activities and time basis for a Protection System Maintenance Program to a level of detail not previously required.

Please clarify what is meant by “restore” in the definition of maintenance.

The description of “restore” in the definition of a Protection System Maintenance Program addresses corrective activities necessary to assure that the component is returned to working order following the discovery of its failure or malfunction. The Maintenance Activities specified in the Tables do not present any requirements related to Restoration; Requirement R5 of the standard does require that the entity “shall demonstrate efforts to correct any identified Unresolved Maintenance Issues.” Some examples of restoration (or correction of Unresolved Maintenance Issues) include, but are not limited to, replacement of capacitors in distance relays to bring them to working order; replacement of relays, or other Protection System components, to bring the Protection System to working order; upgrade of electromechanical or solid-state protective relays to microprocessor-based relays following the discovery of failed components. Restoration, as used in this context, is not to be confused with restoration rules as used in system operations. Maintenance activity necessarily includes both the detection of problems and the repairs needed to eliminate those problems. This standard does not identify all of the Protection System problems that must be detected and eliminated, rather it is the intent of this standard that an entity determines the necessary working order for their various devices, and keeps them in working order. If an equipment item is repaired or replaced, then the entity can restart the maintenance-time-interval-clock, if desired; however, the replacement of equipment does not remove any documentation requirements that would have been required to verify compliance with time-interval requirements. In other words, do not discard maintenance data that goes to verify your work.

The retention of documentation for new and/or replaced equipment provides evidence that the maintenance intervals have been compliant. For example, a long-range plan of upgrades might lead an entity to ignore required maintenance; retaining the evidence of prior maintenance that existed before any retirements and upgrades proves compliance with the standard.

Please clarify what is meant by “...demonstrate efforts to correct an Unresolved Maintenance Issue...;” why not measure the completion of the corrective action?

Management of completion of the identified Unresolved Maintenance Issue is a complex topic that falls outside of the scope of this standard. There can be any number of supply, process and management problems that make setting repair deadlines impossible. The SDT specifically chose the phrase “demonstrate efforts to correct” (with guidance from NERC Staff) because of the concern that many more complex Unresolved Maintenance Issues might require greater than the remaining maintenance interval to resolve (and yet still be a “closed-end process”). For example, a problem might be identified on a VRLA battery during a six-month check. In instances such as one that requiring battery replacement as part of the long-term resolution, it is highly unlikely that the battery could be replaced in time to meet the six-calendar-month requirement for this maintenance activity. The SDT does not believe entities should be found in violation of a maintenance program requirement because of the inability to complete a remediation program within the original maintenance interval. The SDT does believe corrective actions should be timely, but concludes it would be impossible to postulate all possible remediation projects; and, therefore, impossible to specify bounding time frames for resolution of all possible Unresolved Maintenance Issues, or what documentation might be sufficient to provide proof that effective corrective action is being undertaken.

5. Time-Based Maintenance (TBM) Programs

Time-based maintenance is the process in which Protection System, Automatic Reclosing and Sudden Pressure Relaying Components are maintained or verified according to a time schedule. The scheduled program often calls for technicians to travel to the physical site and perform a functional test on Protection System components. However, some components of a TBM program may be conducted from a remote location—for example, tripping a circuit breaker by communicating a trip command to a microprocessor relay to determine if the entire Protection System tripping chain is able to operate the breaker. Similarly, all Protection System, and Sudden Pressure Relaying Components, can have the ability to remotely conduct tests, either on-command or routinely; the running of these tests can extend the time interval between hands-on maintenance activities.

5.1 Maintenance Practices

Maintenance and testing programs often incorporate the following types of maintenance practices:

- TBM – time-based maintenance – externally prescribed maximum maintenance or testing intervals are applied for components or groups of components. The intervals may have been developed from prior experience or manufacturers’ recommendations. The TBM verification interval can be based on a variety of factors, including experience of the particular asset owner, collective experiences of several asset owners who are members of a country or regional council, etc. The maintenance intervals are fixed and may range in number from months to years.

TBM can include review of recent power system events near the particular terminal. Operating records may verify that some portion of the Protection System has operated correctly since the last test occurred. If specific protection scheme components have demonstrated correct performance within specifications, the maintenance test time clock can be reset for those components.

- PBM – Performance-Based Maintenance - intervals are established based on analytical or historical results of TBM failure rates on a statistically significant population of similar components. Some level of TBM is generally followed. Statistical analyses accompanied by adjustments to maintenance intervals are used to justify continued use of PBM-developed extended intervals when test failures or in-service failures occur infrequently.
- CBM – condition-based maintenance – continuously or frequently reported results from non-disruptive self-monitoring of components demonstrate operational status as those components remain in service. Whatever is verified by CBM does not require manual testing, but taking advantage of this requires precise technical focus on exactly what parts are included as part of the self-diagnostics. While the term “Condition-Based-Maintenance” (CBM) is no longer used within the standard itself, it is important to note that the concepts of CBM are a part of the standard (in the form of extended time intervals through status-monitoring). These extended time intervals are only allowed (in the absence of PBM) if the condition of the device is continuously monitored ~~(CBM)~~. As a consequence of the “monitored-basis-time-intervals” existing within the standard, the

explanatory discussions within this Supplementary Reference concerned with CBM will remain in this reference and are discussed as CBM.

Microprocessor-based Protection System or Automatic Reclosing Components that perform continuous self-monitoring verify correct operation of most components within the device. Self-monitoring capabilities may include battery continuity, float voltages, unintentional grounds, the ac signal inputs to a relay, analog measuring circuits, processors and memory for measurement, protection, and data communications, trip circuit monitoring, and protection or data communications signals (and many, many more measurements). For those conditions, failure of a self-monitoring routine generates an alarm and may inhibit operation to avoid false trips. When internal components, such as critical output relay contacts, are not equipped with self-monitoring, they can be manually tested. The method of testing may be local or remote, or through inherent performance of the scheme during a system event.

The TBM is the overarching maintenance process of which the other types are subsets. Unlike TBM, PBM intervals are adjusted based on good or bad experiences. The CBM verification intervals can be hours, or even milliseconds between non-disruptive self-monitoring checks within or around components as they remain in service.

TBM, PBM, and CBM can be combined for individual components, or within a complete Protection System. The following diagram illustrates the relationship between various types of maintenance practices described in this section. In the Venn diagram, the overlapping regions show the relationship of TBM with PBM historical information and the inherent continuous monitoring offered through CBM.

This figure shows:

- Region 1: The TBM intervals that are increased based on known reported operational condition of individual components that are monitoring themselves.
- Region 2: The TBM intervals that are adjusted up or down based on results of analysis of maintenance history of statistically significant population of similar products that have been subject to TBM.
- Region 3: Optimal TBM intervals based on regions 1 and 2.

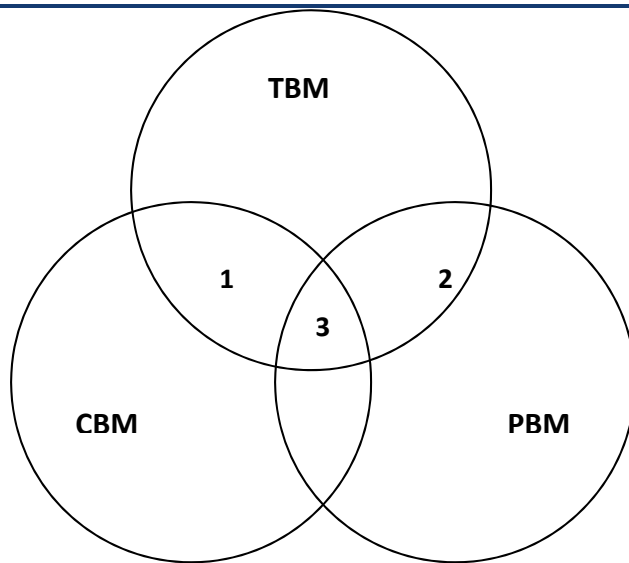

Relationship of time-based maintenance types

5.1.1 Frequently Asked Questions:

The standard seems very complicated, and is difficult to understand. Can it be simplified?

Because the standard is establishing parameters for condition-based Maintenance (Requirement R1) and Performance-Based Maintenance (Requirement R2), in addition to simple time-based Maintenance, it does appear to be complicated. At its simplest, an entity needs to ONLY perform time-based maintenance according to the unmonitored rows of the Tables. If an entity then wishes to take advantage of monitoring on its Protection System components and its available lengthened time intervals, then it may, as long as the component has the listed monitoring attributes. If an entity wishes to use historical performance of its Protection System components to perform Performance-Based Maintenance, then Requirement R2 applies.

Please see the following diagram, which provides a “flow chart” of the standard.

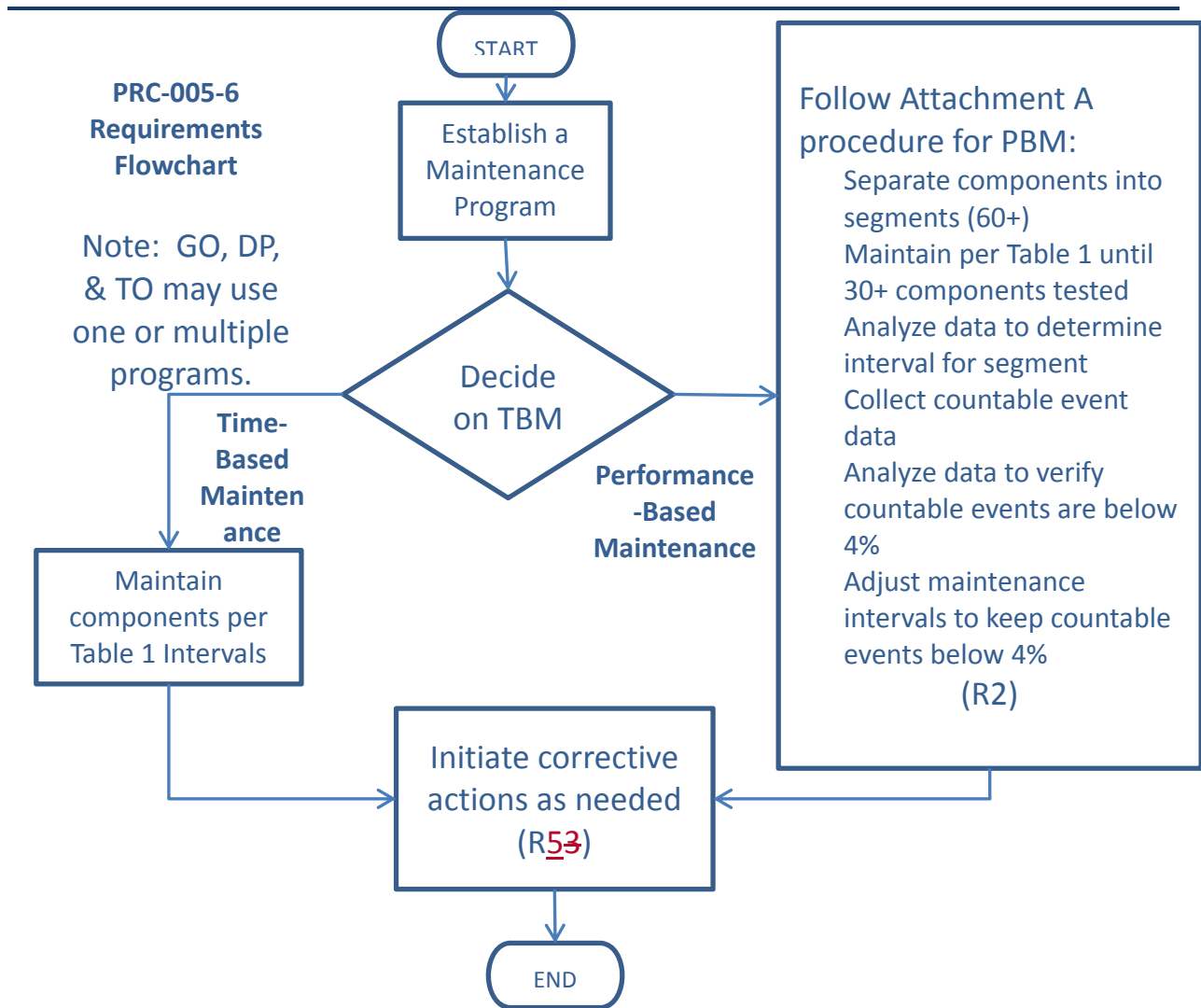

We have an electromechanical (unmonitored) relay that has a trip output to a lockout relay (unmonitored) which trips our transformer off-line by tripping the transformer's high-side and low-side circuit breakers. What testing must be done for this system?

This system is made up of components that are all unmonitored. Assuming a time-based Protection System Maintenance Program schedule (as opposed to a Performance-Based maintenance program), each component must be maintained per the most frequent hands-on activities listed in the Tables.

5.2 Extending Time-Based Maintenance

All maintenance is fundamentally time-based. Default time-based intervals are commonly established to assure proper functioning of each component of the Protection System, when data on the reliability of the components is not available other than observations from time-based maintenance. The following factors may influence the established default intervals:

- If continuous indication of the functional condition of a component is available (from relays or chargers or any self-monitoring device), then the intervals may be extended, or manual testing may be eliminated. This is referred to as condition-based maintenance or CBM. CBM is valid only for precisely the components subject to monitoring. In the case

of microprocessor-based relays, self-monitoring may not include automated diagnostics of every component within a microprocessor.

- Previous maintenance history for a group of components of a common type may indicate that the maintenance intervals can be extended, while still achieving the desired level of performance. This is referred to as Performance-Based Maintenance, or PBM. It is also sometimes referred to as reliability-centered maintenance, or RCM; but PBM is used in this document.
- Observed proper operation of a component may be regarded as a maintenance verification of the respective component or element in a microprocessor-based device. For such an observation, the maintenance interval may be reset only to the degree that can be verified by data available on the operation. For example, the trip of an electromechanical relay for a Fault verifies the trip contact and trip path, but only through the relays in series that actually operated; one operation of this relay cannot verify correct calibration.

Excessive maintenance can actually decrease the reliability of the component or system. It is not unusual to cause failure of a component by removing it from service and restoring it. The improper application of test signals may cause failure of a component. For example, in electromechanical overcurrent relays, test currents have been known to destroy convolution springs.

In addition, maintenance usually takes the component out of service, during which time it is not able to perform its function. Cutout switch failures, or failure to restore switch position, commonly lead to protection failures.

5.2.1 Frequently Asked Questions:

If I show the protective device out of service while it is being repaired, then can I add it back as a new protective device when it returns? If not, my relay testing history would show that I was out of compliance for the last maintenance cycle.

The maintenance and testing requirements (R5) (in essence) state "...shall demonstrate efforts to correct identified Unresolved Maintenance Issues." The type of corrective activity is not stated; however, it could include repairs or replacements.

Your documentation requirements will increase, of course, to demonstrate that your device test failed and had corrective actions initiated. Your regional entity will likely request documentation showing the status of your corrective actions.

6. Condition-Based Maintenance (CBM) Programs

Condition-based maintenance is the process of gathering and monitoring the information available from modern microprocessor-based relays and other intelligent electronic devices (IEDs) that monitor Protection System or Automatic Reclosing elements. These devices generate monitoring information during normal operation, and the information can be assessed at a convenient location remote from the substation. The information from these relays and IEDs is divided into two basic types:

1. Information can come from background self-monitoring processes, programmed by the manufacturer, or by the user in device logic settings. The results are presented by alarm contacts or points, front panel indications, and by data communications messages.
2. Information can come from event logs, captured files, and/or oscillographic records for Faults and Disturbances, metered values, and binary input status reports. Some of these are available on the device front panel display, but may be available via data communications ports. Large files of Fault information can only be retrieved via data communications. These results comprise a mass of data that must be further analyzed for evidence of the operational condition of the Protection System.

Using these two types of information, the user can develop an effective maintenance program carried out mostly from a central location remote from the substation. This approach offers the following advantages:

Non-invasive Maintenance: The system is kept in its normal operating state, without human intervention for checking. This reduces risk of damage, or risk of leaving the system in an inoperable state after a manual test. Experience has shown that keeping human hands away from equipment known to be working correctly enhances reliability.

Virtually Continuous Monitoring: CBM will report many hardware failure problems for repair within seconds or minutes of when they happen. This reduces the percentage of problems that are discovered through incorrect relaying performance. By contrast, a hardware failure discovered by TBM may have been present for much of the time interval between tests, and there is a good chance that some devices will show health problems by incorrect operation before being caught in the next test round. The frequent or continuous nature of CBM makes the effective verification interval far shorter than any required TBM maximum interval. To use the extended time intervals available through Condition Based Maintenance, simply look for the rows in the Tables that refer to monitored items.

6.1 Frequently Asked Questions:

My microprocessor relays and dc circuit alarms are contained on relay panels in a 24-hour attended control room. Does this qualify as an extended time interval condition-based (monitored) system?

Yes, provided the station attendant (plant operator, etc.) monitors the alarms and other indications (comparable to the monitoring attributes) and reports them within the given time limits that are stated in the criteria of the Tables.

When documenting the basis for inclusion of components into the appropriate levels of monitoring, as per Requirement R1 (Part 1.2) of the standard, is it necessary to

provide this documentation about the device by listing of every component and the specific monitoring attributes of each device?

No--While maintaining this documentation on the device level would certainly be permissible, it is not necessary. Global statements can be made to document appropriate levels of monitoring for the entire population of a component type or portion thereof.

For example, it would be permissible to document the conclusion that all BES substation dc supply battery chargers are monitored by stating the following within the program description:

“All substation dc supply battery chargers are considered monitored and subject to the rows for monitored equipment of Table 1-4 requirements, as all substation dc supply battery chargers are equipped with dc voltage alarms and ground detection alarms that are sent to the manned control center.”

Similarly, it would be acceptable to use a combination of a global statement and a device-level list of exclusions. Example:

“Except as noted below, all substation dc supply battery chargers are considered monitored and subject to the rows for monitored equipment of Table 1-4 requirements, as all substation dc supply battery chargers are equipped with dc voltage alarms and ground detection alarms that are sent to the manned control center. The dc supply battery chargers of Substation X, Substation Y, and Substation Z are considered unmonitored and subject to the rows for unmonitored equipment in Table 1-4 requirements, as they are not equipped with ground detection capability.”

Regardless whether this documentation is provided by device listing of monitoring attributes, by global statements of the monitoring attributes of an entire population of component types, or by some combination of these methods, it should be noted that auditors may request supporting drawings or other documentation necessary to validate the inclusion of the device(s) within the appropriate level of monitoring. This supporting background information need not be maintained within the program document structure, but should be retrievable if requested by an auditor.

7. Time-Based Versus Condition-Based Maintenance

Time-based and condition-based (or monitored) maintenance programs are both acceptable, if implemented according to technically sound requirements. Practical programs can employ a combination of time-based and condition-based maintenance. The standard requirements introduce the concept of optionally using condition monitoring as a documented element of a maintenance program.

The Federal Energy Regulatory Commission (FERC), in its Order Number 693 Final Rule, dated March 16, 2007 (18 CFR Part 40, Docket No. RM06-16-000) on Mandatory Reliability Standards for the Bulk-Power System, directed NERC to submit a modification to PRC-005-1b that includes a requirement that maintenance and testing of a Protection System must be carried out within a maximum allowable interval that is appropriate to the type of the Protection System and its impact on the reliability of the Bulk Power System. Accordingly, this Supplementary Reference Paper refers to the specific maximum allowable intervals in PRC-005-6. The defined time limits allow for longer time intervals if the maintained component is monitored.

A key feature of condition-based monitoring is that it effectively reduces the time delay between the moment of a protection failure and time the Protection System or Automatic Reclosing owner knows about it, for the monitored segments of the Protection System. In some cases, the verification is practically continuous--the time interval between verifications is minutes or seconds. Thus, technically sound, condition-based verification, meets the verification requirements of the FERC order even more effectively than the strictly time-based tests of the same system components.

The result is that:

This NERC standard permits applicable entities~~utilities~~ to use a technically sound approach and to take advantage of remote monitoring, data analysis, and control capabilities of modern Protection System and Automatic Reclosing Components to reduce the need for periodic site visits and invasive testing of components by on-site technicians. This periodic testing must be conducted within the maximum time intervals specified in the Tables of PRC-005-6.

7.1 Frequently Asked Questions:

What is a Calendar Year?

Calendar Year - January 1 through December 31 of any year. As an example, if an event occurred on June 17, 2009 and is on a "One Calendar Year Interval," the next event would have to occur on or before December 31, 2010.

Please provide an example of "4 Calendar Months".

If a maintenance activity is described as being needed every four Calendar Months then it is performed in a (given) month and due again four months later. For example a battery bank is inspected in month number 1 then it is due again before the end of the month number 5. And specifically consider that you perform your battery inspection on January 3, ~~2010~~ then it must be inspected again before the end of May. Another example could be that a four-month inspection was performed in January is due in May, but if performed in March (instead of May) would still

be due four months later therefore the activity is due again July. Basically every “four Calendar Months” means to add four months from the last time the activity was performed and perform the activity by the end of the fourth month.

Please provide an example of the unmonitored versus other levels of monitoring available?

An unmonitored Protection System has no monitoring and alarm circuits on the Protection System components. A Protection System component that has monitoring attributes but no alarm output connected is considered to be unmonitored.

A monitored Protection System or an individual monitored component of a Protection System has monitoring and alarm circuits on the Protection System components. The alarm circuits must alert, within 24 hours, a location wherein corrective action can be initiated. This location might be, but is not limited to, an Operations Center, Dispatch Office, Maintenance Center or even a portable SCADA system.

There can be a combination of monitored and unmonitored Protection Systems within any given scheme, substation or plant; there can also be a combination of monitored and unmonitored components within any given Protection System.

Example #1: A combination of monitored and unmonitored components within a given Protection System might be:

- A microprocessor relay with an internal alarm connected to SCADA to alert 24-hr staffed operations center; it has internal self-diagnosis and alarming. (monitored)
- Instrumentation transformers, with no monitoring, connected as inputs to that relay. (unmonitored)
- A vented Lead-Acid battery with a low voltage alarm for the station dc supply voltage and an unintentional grounds detection alarm connected to SCADA. (monitoring varies)
- A circuit breaker with a trip coil, and the trip circuit is not monitored. (unmonitored)

Given the particular components and conditions, and using Table 1 and Table 2, the particular components have maximum activity intervals of:

Every four calendar months, inspect:

- Electrolyte level (station dc supply voltage and unintentional ground detection is being maintained more frequently by the monitoring system).

Every 18 calendar months, verify/inspect the following:

- Battery bank ohmic values to station battery baseline (if performance tests are not opted)
- Battery charger float voltage
- Battery rack integrity
- Cell condition of all individual battery cells (where visible)
- Battery continuity

-
- Battery terminal connection resistance
 - Battery cell-to-cell resistance (where available to measure)

Every six calendar years, perform/verify the following:

- Battery performance test (if internal ohmic tests or other measurements indicative of battery performance are not opted)
- Verify that each trip coil is able to operate the circuit breaker, interrupting device, or mitigating device
- For electromechanical lock-out relays, electrical operation of electromechanical trip

Every 12 calendar years, verify the following:

- Microprocessor relay settings are as specified
- Operation of the microprocessor's relay inputs and outputs that are essential to proper functioning of the Protection System
- Acceptable measurement of power System input values seen by the microprocessor protective relay
- Verify that current and voltage signal values are provided to the protective relays
- Protection System component monitoring for the battery system signals are conveyed to a location where corrective action can be initiated
- The microprocessor relay alarm signals are conveyed to a location where corrective action can be initiated
- Verify all trip paths in the control circuitry associated with protective functions through the trip coil(s) of the circuit breakers or other interrupting devices
- Auxiliary outputs that are in the trip path shall be maintained as detailed in Table 1-5 of the standard under the 'Unmonitored Control Circuitry Associated with Protective Functions' section'
- Auxiliary outputs not in a trip path (i.e., annunciation or DME input) are not required, by this standard, to be checked

Example #2: A combination of monitored and unmonitored components within a given Protection System might be:

- A microprocessor relay with integral alarm that is not connected to SCADA. (unmonitored)
- Current and voltage signal values, with no monitoring, connected as inputs to that relay. (unmonitored)
- A vented lead-acid battery with a low voltage alarm for the station dc supply voltage and an unintentional grounds detection alarm connected to SCADA. (monitoring varies)
- A circuit breaker with a trip coil, with no circuits monitored. (unmonitored)

Given the particular components and conditions, and using the Table 1 (Maximum Allowable Testing Intervals and Maintenance Activities) and Table 2 (Alarming Paths and Monitoring), the particular components have maximum activity intervals of:

Every four calendar months, inspect:

- Electrolyte level (station dc supply voltage and unintentional ground detection is being maintained more frequently by the monitoring system)

Every 18 calendar months, verify/inspect the following:

- Battery bank trending of ohmic values or other measurements indicative of battery performance to station battery baseline (if performance tests are not opted)
- Battery charger float voltage
- Battery rack integrity
- Cell condition of all individual battery cells (where visible)
- Battery continuity
- Battery terminal connection resistance
- Battery cell-to-cell resistance (where available to measure)

Every six calendar years, verify/perform the following:

- Verify operation of the relay inputs and outputs that are essential to proper functioning of the Protection System
- Verify acceptable measurement of power system input values as seen by the relays
- Verify that each trip coil is able to operate the circuit breaker, interrupting device, or mitigating device
- For electromechanical lock-out relays, electrical operation of electromechanical trip
- Battery performance test (if internal ohmic tests are not opted)

Every 12 calendar years, verify the following:

- Current and voltage signal values are provided to the protective relays
- Protection System component monitoring for the battery system signals are conveyed to a location where corrective action can be initiated
- All trip paths in the control circuitry associated with protective functions through the trip coil(s) of the circuit breakers or other interrupting devices
- Auxiliary outputs that are in the trip path shall be maintained, as detailed in Table 1-5 of the standard under the Unmonitored Control Circuitry Associated with Protective Functions" section
- Auxiliary outputs not in a trip path (i.e., annunciation or DME input) are not required, by this standard, to be checked

Example #3: A combination of monitored and unmonitored components within a given Protection System might be:

- A microprocessor relay with alarm connected to SCADA to alert 24-hr staffed operations center; it has internal self-diagnosis and alarms. (monitored)

-
- Current and voltage signal values, with monitoring, connected as inputs to that relay (monitored)
 - Vented Lead-Acid battery without any alarms connected to SCADA (unmonitored)
 - Circuit breaker with a trip coil, with no circuits monitored (unmonitored)

Given the particular components, conditions, and using the Table 1 (Maximum Allowable Testing Intervals and Maintenance Activities) and Table 2 (Alarming Paths and Monitoring), the particular components shall have maximum activity intervals of:

Every four calendar months, verify/inspect the following:

- Station dc supply voltage
- For unintentional grounds
- Electrolyte level

Every 18 calendar months, verify/inspect the following:

- Battery bank trending of ohmic values or other measurements indicative of battery performance to station battery baseline (if performance tests are not opted)
- Battery charger float voltage
- Battery rack integrity
- Battery continuity
- Battery terminal connection resistance
- Battery cell-to-cell resistance (where available to measure)
- Condition of all individual battery cells (where visible)

Every six calendar years, perform/verify the following:

- Battery performance test (if internal ohmic tests or other measurements indicative of battery performance are not opted)
- Verify that each trip coil is able to operate the circuit breaker, interrupting device, or mitigating device
- For electromechanical lock-out relays, electrical operation of electromechanical trip

Every 12 calendar years, verify the following:

- The microprocessor relay alarm signals are conveyed to a location where corrective action can be taken
- Microprocessor relay settings are as specified
- Operation of the microprocessor's relay inputs and outputs that are essential to proper functioning of the Protection System
- Acceptable measurement of power system input values seen by the microprocessor protective relay
- Verify all trip paths in the control circuitry associated with protective functions through the trip coil(s) of the circuit breakers or other interrupting devices

-
- Auxiliary outputs that are in the trip path shall be maintained, as detailed in Table 1-5 of the standard under the Unmonitored Control Circuitry Associated with Protective Functions section
 - Auxiliary outputs not in a trip path (i.e. annunciation or DME input) are not required, by this standard, to be checked

Why do components have different maintenance activities and intervals if they are monitored?

The rationale supporting different activities and intervals for monitored equipment is to allow less frequent manual intervention when more information is known about the condition of Protection System components. Condition-Based Maintenance is a valuable asset to improve reliability.

Can all components in a Protection System be monitored?

No--For some components in a Protection System, monitoring will not be relevant. For example, a battery will always need some kind of inspection.

We have a 30-year-old oil circuit breaker with a red indicating lamp on the substation relay panel that is illuminated only if there is continuity through the breaker trip coil. There is no SCADA monitor or relay monitor of this trip coil. The line protection relay package that trips this circuit breaker is a microprocessor relay that has an integral alarm relay that will assert on a number of conditions that includes a loss of power to the relay. This alarm contact connects to our SCADA system and alerts our 24-hour operations center of relay trouble when the alarm contact closes. This microprocessor relay trips the circuit breaker only and does not monitor trip coil continuity or other things such as trip current. Are the components monitored or not? How often must I perform maintenance?

The protective relay is monitored and can be maintained every 12 years, or when an Unresolved Maintenance Issue arises. The control circuitry can be maintained every 12 years. The circuit breaker trip coil(s) has to be electrically operated at least once every six years.

What is a mitigating device?

A mitigating device is the device that acts to respond as directed by a Remedial Action Schemes. It may be a breaker, valve, distributed control system, or any variety of other devices. This response may include tripping, closing, or other control actions.

8. Maximum Allowable Verification Intervals

The maximum allowable testing intervals and maintenance activities show how CBM with newer device types can reduce the need for many of the tests and site visits that older Protection System components require. As explained below, there are some sections of the Protection System that monitoring or data analysis may not verify. Verifying these sections of the Protection System or Automatic Reclosing requires some persistent TBM activity in the maintenance program. However, some of this TBM can be carried out remotely—for example, exercising a circuit breaker through the relay tripping circuits using the relay remote control capabilities can be used to verify function of one tripping path and proper trip coil operation, if there has been no Fault or routine operation to demonstrate performance of relay tripping circuits.

8.1 Maintenance Tests

Periodic maintenance testing is performed to ensure that the protection and control system is operating correctly after a time period of field installation. These tests may be used to ensure that individual components are still operating within acceptable performance parameters - this type of test is needed for components susceptible to degraded or changing characteristics due to aging and wear. Full system performance tests may be used to confirm that the total Protection System functions from measurement of power system values, to properly identifying Fault characteristics, to the operation of the interrupting devices.

8.1.1 Table of Maximum Allowable Verification Intervals

Table 1 (collectively known as Table 1, individually called out as Tables 1-1 through 1-5), Table 2, Table 3, Table 4-1 through Table 4-3, and Table 5 in the standard specify maximum allowable verification intervals for various generations of Protection Systems, Automatic Reclosing and Sudden Pressure Relaying and categories of equipment that comprise these systems. The right column indicates maintenance activities required for each category.

The types of components are illustrated in [Figures 1](#) and 2 at the end of this paper. Figure 1 shows an example of telecommunications-assisted transmission Protection System comprising substation equipment at each terminal and a telecommunications channel for relaying between the two substations. [Figure 2](#) shows an example of a generation Protection System. The various sub-systems of a Protection System that need to be verified are shown.

Non-distributed UFLS, UVLS, and RAS are additional categories of Table 1 that are not illustrated in these figures. Non-distributed UFLS, UVLS and RAS all use identical equipment as Protection Systems in the performance of their functions; and, therefore, have the same maintenance needs.

Distributed UFLS and UVLS Systems, which use local sensing on the distribution System and trip co-located non-BES interrupting devices, are addressed in Table 3 with reduced maintenance activities.

While it is easy to associate protective relays to multiple levels of monitoring, it is also true that most of the components that can make up a Protection System can also have technological advancements that place them into higher levels of monitoring.

To use the Maintenance Activities and Intervals Tables from PRC-005-6:

-
- First find the Table associated with your component. The tables are arranged in the order of mention in the definition of Protection System;
 - Table 1-1 is for protective relays,
 - Table 1-2 is for the associated communications systems,
 - Table 1-3 is for current and voltage sensing devices,
 - Table 1-4 is for station dc supply and
 - Table 1-5 is for control circuits.
 - Table 2, is for alarms; this was broken out to simplify the other tables.
 - Table 3 is for components which make-up distributed UFLS and UVLS Systems.
 - Table 4 is for Automatic Reclosing.
 - Table 5 is for Sudden Pressure Relaying.
 - Next, look within that table for your device and its degree of monitoring. The Tables have different hands-on maintenance activities prescribed depending upon the degree to which you monitor your equipment. Find the maintenance activity that applies to the monitoring level that you have on your piece of equipment.
 - This Maintenance activity is the minimum maintenance activity that must be documented.
 - If your Performance-Based Maintenance (PBM) plan requires more activities, then you must perform and document to this higher standard. (Note that this does not apply unless you utilize PBM.)
 - After the maintenance activity is known, check the maximum maintenance interval; this time is the maximum time allowed between hands-on maintenance activity cycles of this component.
 - If your Performance-Based Maintenance plan requires activities more often than the Tables maximum, then you must perform and document those activities to your more stringent standard. (Note that this does not apply unless you utilize PBM.)
 - Any given component of a Protection System can be determined to have a degree of monitoring that may be different from another component within that same Protection System. For example, in a given Protection System it is possible for an entity to have a monitored protective relay and an unmonitored associated communications system; this combination would require hands-on maintenance activity on the relay at least once every 12 years and attention paid to the communications system as often as every four months.
 - An entity does not have to utilize the extended time intervals made available by this use of condition-based monitoring. An easy choice to make is to simply utilize the unmonitored level of maintenance made available in each of the Tables. While the maintenance activities resulting from this choice would require more maintenance man-

hours, the maintenance requirements may be simpler to document and the resulting maintenance plans may be easier to create.

For each Protection System Component, Table 1 shows maximum allowable testing intervals for the various degrees of monitoring. For each Automatic Reclosing Component, Table 4 shows maximum allowable testing intervals for the various degrees of monitoring. These degrees of monitoring, or levels, range from the legacy unmonitored through a system that is more comprehensively monitored.

It has been noted here that an entity may have a PSMP that is more stringent than PRC-005-6. There may be any number of reasons that an entity chooses a more stringent plan than the minimums prescribed within PRC-005-6, most notable of which is an entity using performance based maintenance methodology.

If an entity has a Performance-Based Maintenance program, then that plan must be followed, even if the plan proves to be more stringent than the minimums laid out in the Tables.

If an entity has a Time-Based Maintenance program and the PSMP is more stringent than PRC-005-6, they will only be audited in accordance with the standard (minimum maintenance activities and maximum maintenance intervals prescribed within Tables 1-1 through 1-5, Table 2, Table 3, Table 4-1 through 4-3, and Table 5).

8.1.2 Additional Notes for Tables 1-1 through 1-5, Table 3, and Table 4

1. For electromechanical relays, adjustment is required to bring measurement accuracy within the tolerance needed by the asset owner. Microprocessor relays with no remote monitoring of alarm contacts, etc., are unmonitored relays and need to be verified within the Table interval as other unmonitored relays but may be verified as functional by means other than testing by simulated inputs.
2. Microprocessor relays typically are specified by manufacturers as not requiring calibration, but acceptable measurement of power system input values must be verified (verification of the Analog to Digital [A/D] converters) within the Table intervals. The integrity of the digital inputs and outputs that are used as protective functions must be verified within the Table intervals.
3. Any Phasor Measurement Unit (PMU) function whose output is used in a Protection System or RAS (as opposed to a monitoring task) must be verified as a component in a Protection System.
4. In addition to verifying the circuitry that supplies dc to the Protection System, the owner must maintain the station dc supply. The most widespread station dc supply is the station battery and charger. Unlike most Protection System components, physical inspection of station batteries for signs of component failure, reduced performance, and degradation are required to ensure that the station battery is reliable enough to deliver dc power when required. IEEE Standards 450, 1188, and 1106 for vented lead-acid, valve-regulated lead-acid, and nickel-cadmium batteries, respectively (which are the most commonly used substation batteries on the NERC BES) have been developed as an important reference source of maintenance recommendations. The Protection System owner might want to follow the guidelines in the applicable IEEE recommended practices for battery maintenance and testing, especially if the battery in question is used for application requirements in addition to the protection and control demands covered under this

standard. However, the Standard Drafting Team has tailored the battery maintenance and testing guidelines in PRC-005-6 for the Protection System owner which are application specific for the BES Facilities. While the IEEE recommendations are all encompassing, PRC-005-6 is a more economical approach while addressing the reliability requirements of the BES.

5. Aggregated small entities might distribute the testing of the population of UFLS/UVLS systems, and large entities will usually maintain a portion of these systems in any given year. Additionally, if relatively small quantities of such systems do not perform properly, it will not affect the integrity of the overall program. Thus, these distributed systems have decreased requirements as compared to other Protection Systems.
6. Voltage and current sensing device circuit input connections to the Protection System relays can be verified by (but not limited to) comparison of measured values on live circuits or by using test currents and voltages on equipment out of service for maintenance. The verification process can be automated or manual. The values should be verified to be as expected (phase value and phase relationships are both equally important to verify).
7. “End-to-end test,” as used in this Supplementary Reference, is any testing procedure that creates a remote input to the local communications-assisted trip scheme. While this can be interpreted as a GPS-type functional test, it is not limited to testing via GPS. Any remote scheme manipulation that can cause action at the local trip path can be used to functionally-test the dc control circuitry. A documented Real-time trip of any given trip path is acceptable in lieu of a functional trip test. It is possible, with sufficient monitoring, to be able to verify each and every parallel trip path that participated in any given dc control circuit trip. Or another possible solution is that a single trip path from a single monitored relay can be verified to be the trip path that successfully tripped during a Real-time operation. The variations are only limited by the degree of engineering and monitoring that an entity desires to pursue.
8. A/D verification may use relay front panel value displays, or values gathered via data communications. Groupings of other measurements (such as vector summation of bus feeder currents) can be used for comparison if calibration requirements assure acceptable measurement of power system input values.
9. Notes 1-8 attempt to describe some testing activities; they do not represent the only methods to achieve these activities, but rather some possible methods. Technological advances, ingenuity and/or industry accepted techniques can all be used to satisfy maintenance activity requirements; the standard is technology- and method-neutral in most cases.

8.1.3 Frequently Asked Questions:

What is meant by “Verify that settings are as specified” maintenance activity in Table 1-1?

Verification of settings is an activity directed mostly towards microprocessor- based relays. For relay maintenance departments that choose to test microprocessor-based relays in the same manner as electromechanical relays are tested, the testing process sometimes requires

that some specific functions be disabled. Later tests might enable the functions previously disabled, but perhaps still other functions or logic statements were then masked out. It is imperative that, when the relay is placed into service, the settings in the relay be the settings that were intended to be in that relay or as the standard states "...settings are as specified."

Many of the microprocessor-based relays available today have software tools which provide this functionality and generate reports for this purpose.

For evidence or documentation of this requirement, a simple recorded acknowledgement that the settings were checked to be as specified is sufficient.

The drafting team was careful not to require "...that the relay settings be correct..." because it was believed that this might then place a burden of proof that the specified settings would result in the correct intended operation of the interrupting device. While that is a noble intention, the measurable proof of such a requirement is immense. The intent is that settings of the component be as specified at the conclusion of maintenance activities, whether those settings may have "drifted" since the prior maintenance or whether changes were made as part of the testing process.

Are electromechanical relays included in the "Verify that settings are as specified" maintenance activity in Table 1-1?

Verification of settings is an activity directed towards the application of protection related functions of microprocessor based relays. Electromechanical relays require calibration verification by voltage and/or current injection; and, thus, the settings are verified during calibration activity. In the example of a time-overcurrent relay, a minor deviation in time dial, versus the settings, may be acceptable, as long as the relay calibration is within accepted tolerances at the injected current amplitudes. A major deviation may require further investigation, as it could indicate a problem with the relay or an incorrect relay style for the application.

The verification of phase current and voltage measurements by comparison to other quantities seems reasonable. How, though, can I verify residual or neutral currents, or 3V0 voltages, by comparison, when my system is closely balanced?

Since these inputs are verified at commissioning, maintenance verification requires ensuring that phase quantities are as expected and that 3IO and 3VO quantities appear equal to or close to 0.

These quantities also may be verified by use of oscillographic records for connected microprocessor relays as recorded during system Disturbances. Such records may compare to similar values recorded at other locations by other microprocessor relays for the same event, or compared to expected values (from short circuit studies) for known Fault locations.

What does this Standard require for testing an auxiliary tripping relay?

Table 1 and Table 3 requires that a trip test must verify that the auxiliary tripping relay(s) and/or lockout relay(s) which are directly in a trip path from the protective relay to the interrupting device trip coil operate(s) electrically. Auxiliary outputs not in a trip path (i.e. annunciation or DME input) are not required, by this standard, to be checked.

Do I have to perform a full end-to-end test of a Remedial Action Schemes?

No--all portions of the RAS need to be maintained, and the portions must overlap, but the overall RAS does not need to have a single end-to-end test. In other words it may be tested in piecemeal fashion provided all of the pieces are verified.

What about RAS interfaces between different entities or owners?

As in all of the Protection System requirements, RAS segments can be tested individually, thus minimizing the need to accommodate complex maintenance schedules.

What do I have to do if I am using a phasor measurement unit (PMU) as part of a Protection System or Remedial Action Schemes?

Any Phasor Measurement Unit (PMU) function whose output is used in a Protection System or Remedial Action Schemes (as opposed to a monitoring task) must be verified as a component in a Protection System.

How do I maintain a Remedial Action Schemes or relay sensing for non-distributed UFLS or UVLS Systems?

Since components of the RAS, UFLS and UVLS are the same types of components as those in Protection Systems, then these components should be maintained like similar components used for other Protection System functions. In many cases the devices for RAS, UFLS and UVLS are also used for other protective functions. The same maintenance activities apply with the exception that distributed systems (UFLS and UVLS) have fewer dc supply and control circuitry maintenance activity requirements.

For the testing of the output action, verification may be by breaker tripping, but may be verified in overlapping segments. For example, an RAS that trips a remote circuit breaker might be tested by testing the various parts of the scheme in overlapping segments. Another method is to document the Real-time tripping of an RAS scheme should that occur. Forced trip tests of circuit breakers (etc.) that are a part of distributed UFLS or UVLS schemes are not required.

The established maximum allowable intervals do not align well with the scheduled outages for my power plant. Can I extend the maintenance to the next scheduled outage following the established maximum interval?

No--you must complete your maintenance within the established maximum allowable intervals in order to be compliant. You will need to schedule your maintenance during available outages to complete your maintenance as required, even if it means that you may do protective relay maintenance more frequently than the maximum allowable intervals. The maintenance intervals were selected with typical plant outages, among other things, in mind.

If I am unable to complete the maintenance, as required, due to a major natural disaster (hurricane, earthquake, etc.), how will this affect my compliance with this standard?

The Sanction Guidelines of the North American Electric Reliability Corporation, effective January 15, 2008, provides that the Compliance Monitor will consider extenuating circumstances when considering any sanctions.

What if my observed testing results show a high incidence of out-of-tolerance relays; or, even worse, I am experiencing numerous relay Misoperations due to the relays being out-of-tolerance?

The established maximum time intervals are mandatory only as a not-to-exceed limitation. The establishment of a maximum is measurable. But any entity can choose to test some or all of their Protection System components more frequently (or to express it differently, exceed the minimum requirements of the standard). Particularly if you find that the maximum intervals in the standard do not achieve your expected level of performance, it is understandable that you would maintain the related equipment more frequently. A high incidence of relay Misoperations is in no one's best interest.

We believe that the four-month interval between inspections is unnecessary. Why can we not perform these inspections twice per year?

The Standard Drafting Team, through the comment process, has discovered that routine monthly inspections are not the norm. To align routine station inspections with other important inspections, the four-month interval was chosen. In lieu of station visits, many activities can be accomplished with automated monitoring and alarming.

Our maintenance plan calls for us to perform routine protective relay tests every 3 years. If we are unable to achieve this schedule, but we are able to complete the procedures in less than the maximum time interval, then are we in or out of compliance?

According to Requirement R3, if you have a time-based maintenance program, then you will be in violation of the standard only if you exceed the maximum maintenance intervals prescribed in the Tables. According to Requirement R4, if your device in question is part of a Performance-Based Maintenance program, then you will be in violation of the standard if you fail to meet your PSMP, even if you do not exceed the maximum maintenance intervals prescribed in the Tables. The intervals in the Tables are associated with TBM and CBM; Attachment A is associated with PBM.

Please provide a sample list of devices or systems that must be verified in a generator, generator step-up transformer, generator connected station service or generator connected excitation transformer to meet the requirements of this maintenance standard.

Examples of typical devices and systems that may directly trip the generator, or trip through a lockout relay, may include, but are not necessarily limited to:

- Fault protective functions, including distance functions, voltage-restrained overcurrent functions, or voltage-controlled overcurrent functions
- Loss-of-field relays
- Volts-per-hertz relays
- Negative sequence overcurrent relays
- Over voltage and under voltage protection relays
- Stator-ground relays
- Communications-based Protection Systems such as transfer-trip systems

-
- Generator differential relays
 - Reverse power relays
 - Frequency relays
 - Out-of-step relays
 - Inadvertent energization protection
 - Breaker failure protection

For generator step-up, generator-connected station service transformers, or generator connected excitation transformers, operation of any of the following associated protective relays frequently would result in a trip of the generating unit; and, as such, would be included in the program:

- Transformer differential relays
- Neutral overcurrent relay
- Phase overcurrent relays
- Sudden Pressure Relaying

Relays which trip breakers serving station auxiliary Loads such as pumps, fans, or fuel handling equipment, etc., need not be included in the program, even if the loss of the those Loads could result in a trip of the generating unit. Furthermore, relays which provide protection to secondary unit substation (SUS) or low switchgear transformers and relays protecting other downstream plant electrical distribution system components are not included in the scope of this program, even if a trip of these devices might eventually result in a trip of the generating unit. For example, a thermal overcurrent trip on the motor of a coal-conveyor belt could eventually lead to the tripping of the generator, but it does not cause the trip.

In the case where a plant does not have a generator connected station service transformer such that it is normally fed from a system connected station service transformer, is it still the drafting team's intent to exclude the Protection Systems for these system connected auxiliary transformers from scope even when the loss of the normal (system connected) station service transformer will result in a trip of a BES generating Facility?

The SDT does not intend that the system-connected station service transformers be included in the Applicability. The generator-connected station service transformers and generator connected excitation transformers are often connected to the generator bus directly without an interposing breaker; thus, the Protection Systems on these transformers will trip the generator as discussed in 4.2.5.1.

What is meant by "verify operation of the relay inputs and outputs that are essential to proper functioning of the Protection System?"

Any input or output (of the relay) that "affects the tripping" of the breaker is included in the scope of I/O of the relay to be verified. By "affects the tripping," one needs to realize that sometimes there are more inputs and outputs than simply the output to the trip coil. Many

important protective functions include things like breaker fail initiation, zone timer initiation and sometimes even 52a/b contact inputs are needed for a protective relay to correctly operate.

Each input should be “picked up” or “turned on and off” and verified as changing state by the microprocessor of the relay. Each output should be “operated” or “closed and opened” from the microprocessor of the relay and the output should be verified to change state on the output terminals of the relay. One possible method of testing inputs of these relays is to “jumper” the needed dc voltage to the input and verify that the relay registered the change of state.

Electromechanical lock-out relays (86) (used to convey the tripping current to the trip coils) need to be electrically operated to prove the capability of the device to change state. These tests need to be accomplished at least every six years, unless PBM methodology is applied.

The contacts on the 86 or auxiliary tripping relays (94) that change state to pass on the trip current to a breaker trip coil need only be checked every 12 years with the control circuitry.

What is the difference between a distributed UFLS/UVLS and a non-distributed UFLS/UVLS scheme?

A distributed UFLS or UVLS scheme contains individual relays which make independent Load shed decisions based on applied settings and localized voltage and/or current inputs. A distributed scheme may involve an enable/disable contact in the scheme and still be considered a distributed scheme. A non-distributed UFLS or UVLS scheme involves a system where there is some type of centralized measurement and Load shed decision being made. A non-distributed UFLS/UVLS scheme is considered similar to an RAS scheme and falls under Table 1 for maintenance activities and intervals.

8.2 Retention of Records

PRC-005-1 describes a reporting or auditing cycle of one year and retention of records for three years. However, with a three-year retention cycle, the records of verification for a Protection System might be discarded before the next verification, leaving no record of what was done if a Misoperation or failure is to be analyzed.

PRC-005-6 corrects this by requiring:

The Transmission Owner, Generator Owner, and Distribution Provider shall each keep data or evidence to show compliance as identified below unless directed by its Compliance Enforcement Authority to retain specific evidence for a longer period of time as part of an investigation.

For Requirement R1, the Transmission Owner, Generator Owner, and Distribution Provider shall each keep its current dated Protection System Maintenance Program, as well as any superseded versions since the preceding compliance audit, including the documentation that specifies the type of maintenance program applied for each Protection System, Automatic Reclosing, or Sudden Pressure Relaying Component Type.

For Requirement R2, Requirement R3, and Requirement R4, in cases where the interval of the maintenance activity is longer than the audit cycle, the Transmission Owner, Generator Owner, and Distribution Provider shall each keep documentation of the most recent performance of that maintenance activity for the Protection System, Automatic Reclosing, or Sudden Pressure Relaying Component. In cases where the interval of the maintenance activity is shorter than the audit cycle, documentation of all performances (in accordance with the tables) of that

maintenance activity for the Protection System, Automatic Reclosing, or Sudden Pressure Relaying Component since the previous scheduled audit date shall be retained.

For Requirement R5 the Transmission Owner, Generator Owner, and Distribution Provider shall each keep documentation of Unresolved Maintenance Issues identified by the entity since the last audit, including all that were resolved since the last audit.

This requirement assures that the documentation shows that the interval between maintenance cycles correctly meets the maintenance interval limits. The requirement is actually alerting the industry to documentation requirements already implemented by audit teams. Evidence of compliance bookending the interval shows interval accomplished instead of proving only your planned interval.

The SDT is aware that, in some cases, the retention period could be relatively long. But, the retention of documents simply helps to demonstrate compliance.

8.2.1 Frequently Asked Questions:

Please clarify the data retention requirements.

The data retention requirements are intended to allow the availability of maintenance records to demonstrate that the time intervals in your maintenance plan were upheld.

<u>Maximum Maintenance Interval</u>	<u>Data Retention Period</u>
4 Months, 6 Months, 18 Months, or 3 Years	All activities since previous audit
6 Years	All activities since previous audit (assuming a 6 year audit cycle) or most recent performance (assuming 3 year audit cycle), whichever is longer
12 Year	All activities from the most recent performance

If an entity prefers to utilize Performance-Based Maintenance, then statistical data may be retained for extended periods to assist with future adjustments in time intervals.

If an equipment item is replaced, then the entity can restart the maintenance-time-interval-clock if desired; however, the replacement of equipment does not remove any documentation requirements that would have been required to verify compliance with time-interval requirements. In other words, do not discard maintenance data that goes to verify your work.

The retention of documentation for new and/or replaced equipment is all about proving that the maintenance intervals had been in compliance. For example, a long-range plan of upgrades might lead an entity to ignore required maintenance; retaining the evidence of prior maintenance that existed before any retirements and upgrades proves compliance with the standard.

What does this Maintenance Standard say about commissioning? Is it necessary to have documentation in your maintenance history of the completion of commission testing?

This standard does not establish requirements for commission testing. Commission testing includes all testing activities necessary to conclude that a Facility has been built in accordance with design. While a thorough commission testing program would include, either directly or indirectly, the verification of all those Protection System attributes addressed by the maintenance activities specified in the Tables of PRC-005-6, verification of the adequacy of initial installation necessitates the performance of testing and inspections that go well beyond these routine maintenance activities. For example, commission testing might set baselines for future tests; perform acceptance tests and/or warranty tests; utilize testing methods that are not generally done routinely like staged-Fault-tests.

However, many of the Protection System attributes which are verified during commission testing are not subject to age related or service related degradation, and need not be re-verified within an ongoing maintenance program. Example--it is not necessary to re-verify correct terminal strip wiring on an ongoing basis.

PRC-005-6 assumes that thorough commission testing was performed prior to a Protection System being placed in service. PRC-005-6 requires performance of maintenance activities that are deemed necessary to detect and correct plausible age and service related degradation of components, such that a properly built and commission tested Protection System will continue to function as designed over its service life.

It should be noted that commission testing frequently is performed by a different organization than that which is responsible for the ongoing maintenance of the Protection System. Furthermore, the commission testing activities will not necessarily correlate directly with the maintenance activities required by the standard. As such, it is very likely that commission testing records will deviate significantly from maintenance records in both form and content; and, therefore, it is not necessary to maintain commission testing records within the maintenance program documentation.

Notwithstanding the differences in records, an entity would be wise to retain commissioning records to show a maintenance start date. (See below). An entity that requires that their commissioning tests have, at a minimum, the requirements of PRC-005-6 would help that entity prove time interval maximums by setting the initial time clock.

How do you determine the initial due date for maintenance?

The initial due date for maintenance should be based upon when a Protection System was tested. Alternatively, an entity may choose to use the date of completion of the commission testing of the Protection System component and the system was placed into service as the starting point in determining its first maintenance due dates. Whichever method is chosen, for newly installed Protection Systems the components should not be placed into service until minimum maintenance activities have taken place.

It is conceivable that there can be a (substantial) difference in time between the date of testing, as compared to the date placed into service. The use of the "Calendar Year" language can help determine the next due date without too much concern about being non-compliant for missing test dates by a small amount (provided your dates are not already at the end of a year). However, if there is a substantial amount of time difference between testing and in-service dates, then the

testing date should be followed because it is the degradation of components that is the concern. While accuracy fluctuations may decrease when components are not energized, there are cases when degradation can take place, even though the device is not energized. Minimizing the time between commissioning tests and in-service dates will help.

If I miss two battery inspections four times out of 100 Protection System components on my transmission system, does that count as 2% or 8% when counting Violation Severity Level (VSL) for R3?

The entity failed to complete its scheduled program on two of its 100 Protection System components, which would equate to 2% for application to the VSL Table for Requirement R3. This VSL is written to compare missed components to total components. In this case two components out of 100 were missed, or 2%.

How do I achieve a “grace period” without being out of compliance?

The objective here is to create a time extension within your own PSMP that still does not violate the maximum time intervals stated in the standard. Remember that the maximum time intervals listed in the Tables cannot be extended.

For the purposes of this example, concentrating on just unmonitored protective relays – Table 1-1 specifies a maximum time interval (between the mandated maintenance activities) of six calendar years. Your plan must ensure that your unmonitored relays are tested at least once every six calendar years. You could, within your PSMP, require that your unmonitored relays be tested every four calendar years, with a maximum allowable time extension of 18 calendar months. This allows an entity to have deadlines set for the auto-generation of work orders, but still has the flexibility in scheduling complex work schedules. This also allows for that 18 calendar months to act as a buffer, in effect a grace period within your PSMP, in the event of unforeseen events. You will note that this example of a maintenance plan interval has a planned time of four years; it also has a built-in time extension allowed within the PSMP, and yet does not exceed the maximum time interval allowed by the standard. So while there are no time extensions allowed beyond the standard, an entity can still have substantial flexibility to maintain their Protection System components.

8.3 Basis for Table 1 Intervals

When developing the original *Protection System Maintenance – A Technical Reference* in 2007, the SPCTF collected all available data from Regional Entities (REs) on time intervals recommended for maintenance and test programs. The recommendations vary widely in categorization of relays, defined maintenance actions, and time intervals, precluding development of intervals by averaging. The SPCTF also reviewed the 2005 Report [2] of the IEEE Power System Relaying Committee Working Group I-17 (Transmission Relay System Performance Comparison). Review of the I-17 report shows data from a small number of utilities, with no company identification or means of investigating the significance of particular results.

To develop a solid current base of practice, the SPCTF surveyed its members regarding their maintenance intervals for electromechanical and microprocessor relays, and asked the members to also provide definitively-known data for other entities. The survey represented 470 GW of peak Load, or 4% of the NERC peak Load. Maintenance interval averages were compiled by weighting reported intervals according to the size (based on peak Load) of the reporting

utility. Thus, the averages more accurately represent practices for the large populations of Protection Systems used across the NERC regions.

The results of this survey with weighted averaging indicate maintenance intervals of five years for electromechanical or solid state relays, and seven years for unmonitored microprocessor relays.

A number of ~~applicable entities~~ utilities have extended maintenance intervals for microprocessor relays beyond seven years, based on favorable experience with the particular products they have installed. To provide a technical basis for such extension, the SPCTF authors developed a recommendation of 10 years using the Markov modeling approach from [1], as summarized in Section 8.4. The results of this modeling depend on the completeness of self-testing or monitoring. Accordingly, this extended interval is allowed by Table 1, only when such relays are monitored as specified in the attributes of monitoring contained in Tables 1-1 through 1-5 and Table 2. Monitoring is capable of reporting Protection System health issues that are likely to affect performance within the 10 year time interval between verifications.

It is important to note that, according to modeling results, Protection System availability barely changes as the maintenance interval is varied below the 10-year mark. Thus, reducing the maintenance interval does not improve Protection System availability. With the assumptions of the model regarding how maintenance is carried out, reducing the maintenance interval actually degrades Protection System availability.

8.4 Basis for Extended Maintenance Intervals for Microprocessor Relays

Table 1 allows maximum verification intervals that are extended based on monitoring level. The industry has experience with self-monitoring microprocessor relays that leads to the Table 1 value for a monitored relay, as explained in Section 8.3. To develop a basis for the maximum interval for monitored relays in their *Protection System Maintenance – A Technical Reference*, the SPCTF used the methodology of Reference [1], which specifically addresses optimum routine maintenance intervals. The Markov modeling approach of [1] is judged to be valid for the design and typical failure modes of microprocessor relays.

The SPCTF authors ran test cases of the Markov model to calculate two key probability measures:

- Relay Unavailability - the probability that the relay is out of service due to failure or maintenance activity while the power system Element to be protected is in service.
- Abnormal Unavailability - the probability that the relay is out of service due to failure or maintenance activity when a Fault occurs, leading to failure to operate for the Fault.

The parameter in the Markov model that defines self-monitoring capability is ST (for self-test). ST = 0 if there is no self-monitoring; ST = 1 for full monitoring. Practical ST values are estimated to range from .75 to .95. The SPCTF simulation runs used constants in the Markov model that were the same as those used in [1] with the following exceptions:

Sn, Normal tripping operations per hour = 21600 (reciprocal of normal Fault clearing time of 10 cycles)

Sb, Backup tripping operations per hour = 4320 (reciprocal of backup Fault clearing time of 50 cycles)

Rc, Protected component repairs per hour = 0.125 (8 hours to restore the power system)

Rt, Relay routine tests per hour = 0.125 (8 hours to test a Protection System)

Rr, Relay repairs per hour = 0.08333 (12 hours to complete a Protection System repair after failure)

Experimental runs of the model showed low sensitivity of optimum maintenance interval to these parameter adjustments.

The resulting curves for relay unavailability and abnormal unavailability versus maintenance interval showed a broad minimum (optimum maintenance interval) in the vicinity of 10 years – the curve is flat, with no significant change in either unavailability value over the range of 9, 10, or 11 years. This was true even for a relay mean time between Failures (MTBF) of 50 years, much lower than MTBF values typically published for these relays. Also, the Markov modeling indicates that both the relay unavailability and abnormal unavailability actually become higher with more frequent testing. This shows that the time spent on these more frequent tests yields no failure discoveries that approach the negative impact of removing the relays from service and running the tests.

The PSMT SDT discussed the practical need for “time-interval extensions” or “grace periods” to allow for scheduling problems that resulted from any number of business contingencies. The time interval discussions also focused on the need to reflect industry norms surrounding Generator outage frequencies. Finally, it was again noted that FERC Order 693 demanded maximum time intervals. “Maximum time intervals” by their very term negates any “time-interval extension” or “grace periods.” To recognize the need to follow industry norms on Generator outage frequencies and accommodate a form of time-interval extension, while still following FERC Order 693, the Standard Drafting Team arrived at a six-year interval for the electromechanical relay, instead of the five-year interval arrived at by the SPCTF. The PSMT SDT has followed the FERC directive for a *maximum* time interval and has determined that no extensions will be allowed. Six years has been set for the maximum time interval between manual maintenance activities. This maximum time interval also works well for maintenance cycles that have been in use in generator plants for decades.

For monitored relays, the PSMT SDT notes that the SPCTF called for 10 years as the interval between maintenance activities. This 10-year interval was chosen, even though there was “...no significant change in unavailability value over the range of 9, 10, or 11 years. This was true even for a relay Mean Time between Failures (MTBF) of 50 years...” The Standard Drafting Team again sought to align maintenance activities with known successful practices and outage schedules. The Standard does not allow extensions on any component of the Protection System; thus, the maximum allowed interval for these components has been set to 12 years. Twelve years also fits well into the traditional maintenance cycles of both substations and generator plants.

Also of note is the Table’s use of the term “Calendar” in the column for “Maximum Maintenance Interval.” The PSMT SDT deemed it necessary to include the term “Calendar” to facilitate annual maintenance planning, scheduling and implementation. This need is the result of known occurrences of system requirements that could cause maintenance schedules to be missed by a few days or weeks. The PSMT SDT chose the term “Calendar” to preclude the need to have schedules be met to the day. An electromechanical protective relay that is maintained in year number one need not be revisited until six years later (year number seven). For example, a relay

was maintained April 10, 2008; maintenance would need to be completed no later than December 31, 2014.

Though not a requirement of this standard, to stay in line with many Compliance Enforcement Agencies audit processes an entity should define, within their own PSMP, the entity's use of terms like annual, calendar year, etc. Then, once this is within the PSMP, the entity should abide by their chosen language.

9. Performance-Based Maintenance Process

In lieu of using the Table 1 intervals, a Performance-Based Maintenance process may be used to establish maintenance intervals (*PRC-005 Attachment A Criteria for a Performance-Based Protection System Maintenance Program*). A Performance-Based Maintenance process may justify longer maintenance intervals, or require shorter intervals relative to Table 1. In order to use a Performance-Based Maintenance process, the documented maintenance program must include records of repairs, adjustments, and corrections to covered Protection Systems in order to provide historical justification for intervals, other than those established in Table 1. Furthermore, the asset owner must regularly analyze these records of corrective actions to develop a ranking of causes. Recurrent problems are to be highlighted, and remedial action plans are to be documented to mitigate or eliminate recurrent problems.

Entities with Performance-Based Maintenance track performance of Protection Systems, demonstrate how they analyze findings of performance failures and aberrations, and implement continuous improvement actions. Since no maintenance program can ever guarantee that no malfunction can possibly occur, documentation of a Performance-Based Maintenance program would serve the utility well in explaining to regulators and the public a Misoperation leading to a major System outage event.

A Performance-Based Maintenance program requires auditing processes like those included in widely used industrial quality systems (such as *ISO 9001-2000, Quality Management Systems — Requirements*; or applicable parts of the NIST Baldrige National Quality Program). The audits periodically evaluate:

- The completeness of the documented maintenance process
- Organizational knowledge of and adherence to the process
- Performance metrics and documentation of results
- Remediation of issues
- Demonstration of continuous improvement.

In order to opt into a Performance-Based Maintenance (PBM) program, the asset owner must first sort the various Components into population segments. Any population segment must be comprised of at least 60 individual units; if any asset owner opts for PBM, but does not own 60 units to comprise a population, then that asset owner may combine data from other asset owners until the needed 60 units is aggregated. Each population segment must be composed of a grouping of Components of a consistent design standard or particular model or type from a single

manufacturer and subjected to similar environmental factors. For example: One segment cannot be comprised of both GE & Westinghouse electro-mechanical lock-out relays; likewise, one segment cannot be comprised of 60 GE lock-out relays, 30 of which are in a dirty environment, and the remaining 30 from a clean environment. This PBM process cannot be applied to batteries, but can be applied to all other Components, including (but not limited to) specific battery chargers, instrument transformers, trip coils and/or control circuitry (etc.).

9.1 Minimum Sample Size

Large Sample Size

An assumption that needs to be made when choosing a sample size is “the sampling distribution of the sample mean can be approximated by a normal probability distribution.” The Central Limit Theorem states: “In selecting simple random samples of size n from a population, the sampling distribution of the sample mean \bar{x} can be approximated by a normal probability distribution as the sample size becomes large.” (Essentials of Statistics for Business and Economics, Anderson, Sweeney, Williams, 2003.)

To use the Central Limit Theorem in statistics, the population size should be large. The references below are supplied to help define what is large.

“... whenever we are using a large simple random sample (rule of thumb: $n \geq 30$), the central limit theorem enables us to conclude that the sampling distribution of the sample mean can be approximated by a normal distribution.” (Essentials of Statistics for Business and Economics, Anderson, Sweeney, Williams, 2003.)

“If samples of size n , when $n \geq 30$, are drawn from any population with a mean μ and a standard deviation σ , the sampling distribution of sample means approximates a normal distribution. The greater the sample size, the better the approximation.” (Elementary Statistics - Picturing the World, Larson, Farber, 2003.)

“The sample size is large (generally $n \geq 30$)... (Introduction to Statistics and Data Analysis - Second Edition, Peck, Olson, Devore, 2005.)

“... the normal is often used as an approximation to the t distribution in a test of a null hypothesis about the mean of a normally distributed population when the population variance is estimated from a relatively large sample. A sample size exceeding 30 is often given as a minimal size in this connection.” (Statistical Analysis for Business Decisions, Peters, Summers, 1968.)

Error of Distribution Formula

Beyond the large sample size discussion above, a sample size requirement can be estimated using the bound on the Error of Distribution Formula when the expected result is of a “Pass/Fail” format and will be between 0 and 1.0.

The Error of Distribution Formula is:

$$B = z \sqrt{\frac{\pi(1-\pi)}{n}}$$

Where:

B = bound on the error of distribution (allowable error)

z = standard error

π = expected failure rate

n = sample size required

Solving for n provides:

$$n = \pi(1 - \pi) \left(\frac{z}{B} \right)^2$$

Minimum Population Size to use Performance-Based Program

One entity's population of components should be large enough to represent a sizeable sample of a vendor's overall population of manufactured devices. For this reason, the following assumptions are made:

B = 5%

z = 1.96 (This equates to a 95% confidence level)

π = 4%

Using the equation above, n=59.0.

Minimum Sample Size to evaluate Performance-Based Program

The number of components that should be included in a sample size for evaluation of the appropriate testing interval can be smaller because a lower confidence level is acceptable since the sample testing is repeated or updated annually. For this reason, the following assumptions are made:

B = 5%

z = 1.44 (85% confidence level)

π = 4%

Using the equation above, n=31.8.

Recommendation

Based on the above discussion, a sample size should be at least 30 to allow use of the equation mentioned. Using this and the results of the equation, the following numbers are recommended (and required within the standard):

Minimum Population Size to use Performance-Based Maintenance Program = 60

Minimum Sample Size to evaluate Performance-Based Program = 30.

Once the population segment is defined, then maintenance must begin within the intervals as outlined for the device described in the Tables 1-1 through 1-5. Time intervals can be lengthened

provided the last year's worth of components tested (or the last 30 units maintained, whichever is more) had fewer than 4% Countable Events. It is notable that 4% is specifically chosen because an entity with a small population (30 units) would have to adjust its time intervals between maintenance if more than one Countable Event was found to have occurred during the last analysis period. A smaller percentage would require that entity to adjust the time interval between maintenance activities if even one unit is found out of tolerance or causes a Misoperation.

The minimum number of units that can be tested in any given year is 5% of the population. Note that this 5% threshold sets a practical limitation on total length of time between intervals at 20 years.

If at any time the number of Countable Events equals or exceeds 4% of the last year's tested components (or the last 30 units maintained, whichever is more), then the time period between manual maintenance activities must be decreased. There is a time limit on reaching the decreased time at which the Countable Events is less than 4%; this must be attained within three years.

Performance-Based Program Evaluation Example

The 4% performance target was derived as a protection system performance target and was selected based on the drafting team's experience and studies performed by several utilities. This is not derived from the performance of discrete devices. Microprocessor relays and electromechanical relays have different performance levels. It is not appropriate to compare these performance levels to each other. The performance of the segment should be compared to the 4% performance criteria.

In consideration of the use of Performance Based Maintenance (PBM), the user should consider the effects of extended testing intervals and the established 4% failure rate. In the table shown below, the segment is 1000 units. As the testing interval (in years) increases, the number of units tested each year decreases. The number of countable events allowed is 4% of the tested units. Countable events are the failure of a Component requiring repair or replacement, any corrective actions performed during the maintenance test on the units within the testing segment (units per year), or any ~~mis~~Misoperation attributable to hardware failure or calibration failure found within the entire segment (1000 units) during the testing year.

Example: 1000 units in the segment with a testing interval of 8 years: The number of units tested each year will be 125 units. The total allowable countable events equals: $125 \times .04 = 5$. This number includes failure of a Component requiring repair or replacement, corrective issues found during testing, and the total number of ~~mis~~Misoperations (attributable to hardware or calibration failure within the testing year) associated with the entire segment of 1000 units.

Example: 1000 units in the segment with a testing interval of 16 years: The number of units tested each year will be 63 units. The total allowable countable events equals: $63 \times .04 = 2.5$.

As shown in the above examples, doubling the testing interval reduces the number of allowable events by half.

Total number of units in the segment	1000
Failure rate	4.00%

Testing Intervals (Years)	Units Per Year	Acceptable Number of Countable Events per year	Yearly Failure Rate Based on 1000 Units in Segment
1	1000.00	40.00	4.00%
2	500.00	20.00	2.00%
4	250.00	10.00	1.00%
6	166.67	6.67	0.67%
8	125.00	5.00	0.50%
10	100.00	4.00	0.40%
12	83.33	3.33	0.33%
14	71.43	2.86	0.29%
16	62.50	2.50	0.25%
18	55.56	2.22	0.22%
20	50.00	2.00	0.20%

Using the prior year’s data, determine the maximum allowable maintenance interval for each Segment such that the Segment experiences Countable Events on no more than 4% of the Components within the Segment, for the greater of either the last 30 Components maintained or all Components maintained in the previous year.

Segment – Components of a consistent design standard, or a particular model or type from a single manufacturer that typically share other common elements. Consistent performance is expected across the entire population of a Segment. A Segment must contain at least sixty (60) individual Components.

Countable Event – A failure of a Component requiring repair or replacement, any condition discovered during the maintenance activities in Tables 1-1 through 1-5, Table 3, Table 4-1 through Table 4-3, and Table 5, which requires corrective action or a Protection System Misoperation attributed to hardware failure or calibration failure. Misoperations due to product design errors, software errors, relay settings different from specified settings, Protection System Component, Automatic Reclosing, or Sudden Pressure Relaying configuration or application errors are not included in Countable Events.

9.2 Frequently Asked Questions:

I’m a small entity and cannot aggregate a population of Protection System components to establish a segment required for a Performance-Based Protection System Maintenance Program. How can I utilize that opportunity?

Multiple asset owning entities may aggregate their individually owned populations of individual Protection System components to create a segment that crosses ownership boundaries. All entities participating in a joint program should have a single documented joint management

process, with consistent Protection System Maintenance Programs (practices, maintenance intervals and criteria), for which the multiple owners are individually responsible with respect to the requirements of the Standard. The requirements established for Performance-Based Maintenance must be met for the overall aggregated program on an ongoing basis.

The aggregated population should reflect all factors that affect consistent performance across the population, including any relevant environmental factors such as geography, power-plant vs. substation, and weather conditions.

Can an owner go straight to a Performance-Based Maintenance program schedule, if they have previously gathered records?

Yes--an owner can go to a Performance-Based Maintenance program immediately. The owner will need to comply with the requirements of a Performance-Based Maintenance program as listed in the Standard. Gaps in the data collected will not be allowed; therefore, if an owner finds that a gap exists such that they cannot prove that they have collected the data as required for a Performance-Based Maintenance program then they will need to wait until they can prove compliance.

When establishing a Performance-Based Maintenance program, can I use test data from the device manufacturer, or industry survey results, as results to help establish a basis for my Performance-Based intervals?

No--you must use actual in-service test data for the components in the segment.

What types of Misoperations or events are not considered Countable Events in the Performance-Based Protection System Maintenance (PBM) Program?

Countable Events are intended to address conditions that are attributed to hardware failure or calibration failure; that is, conditions that reflect deteriorating performance of the component. These conditions include any condition where the device previously worked properly, then, due to changes within the device, malfunctioned or degraded to the point that re-calibration (to within the entity's tolerance) was required.

For this purpose of tracking hardware issues, human errors resulting in Protection System Misoperations during system installation or maintenance activities are not considered Countable Events. Examples of excluded human errors include relay setting errors, design errors, wiring errors, inadvertent tripping of devices during testing or installation, and misapplication of Protection System components. Examples of misapplication of Protection System components include wrong CT or PT tap position, protective relay function misapplication, and components not specified correctly for their installation. Obviously, if one is setting up relevant data about hardware failures then human failures should be eliminated from the hardware performance analysis.

One example of human-error is not pertinent data might be in the area of testing "86" lock-out relays (LOR). "Entity A" has two types of LOR's type "X" and type "Y"; they want to move into a performance based maintenance interval. They have 1000 of each type, so the population variables are met. During electrical trip testing of all of their various schemes over the initial six-year interval they find zero type "X" failures, but human error led to tripping a BES Element 100 times; they find 100 type "Y" failures and had an additional 100 human-error caused tripping incidents. In this example the human-error caused Misoperations should not be used to judge

the performance of either type of LOR. Analysis of the data might lead “Entity A” to change time intervals. Type “X” LOR can be placed into extended time interval testing because of its low failure rate (zero failures) while Type “Y” would have to be tested more often than every 6 calendar years (100 failures divided by 1000 units exceeds the 4% tolerance level).

Certain types of Protection System component errors that cause Misoperations are not considered Countable Events. Examples of excluded component errors include device malfunctions that are correctable by firmware upgrades and design errors that do not impact protection function.

What are some examples of methods of correcting segment performance for Performance-Based Maintenance?

There are a number of methods that may be useful for correcting segment performance for mal-performing segments in a Performance-Based Maintenance system. Some examples are listed below.

- The maximum allowable interval, as established by the Performance-Based Maintenance system, can be decreased. This may, however, be slow to correct the performance of the segment.
- Identifiable sub-groups of components within the established segment, which have been identified to be the mal-performing portion of the segment, can be broken out as an independent segment for target action. Each resulting segment must satisfy the minimum population requirements for a Performance-Based Maintenance program in order to remain within the program.
- Targeted corrective actions can be taken to correct frequently occurring problems. An example would be replacement of capacitors within electromechanical distance relays if bad capacitors were determined to be the cause of the mal-performance.
- Components within the mal-performing segment can be replaced with other components (electromechanical distance relays with microprocessor relays, for example) to remove the mal-performing segment.

If I find (and correct) a Unresolved Maintenance Issue as a result of a Misoperation investigation (Re: PRC-004), how does this affect my Performance-Based Maintenance program?

If you perform maintenance on a Protection System component for any reason (including as part of a PRC-004 required Misoperation investigation/corrective action), the actions performed can count as a maintenance activity provided the activities in the relevant Tables have been done, and, if you desire, “reset the clock” on everything you’ve done. In a Performance-Based Maintenance program, you also need to record the Unresolved Maintenance Issue as a Countable Event within the relevant component group segment and use it in the analysis to determine your correct Performance-Based Maintenance interval for that component group. Note that “resetting the clock” should not be construed as interfering with an entity’s routine testing schedule because the “clock-reset” would actually make for a decreased time interval by the time the next routine test schedule comes around.

For example, a relay scheme, consisting of four relays, is tested on 1-1-11 and the PSMP has a time interval of 3 calendar years with an allowable extension of 1 calendar year. The relay would be due again for routine testing before the end of the year 2015. This hypothetical relay scheme

has a Misoperation on 6-1-12 that points to one of the four relays as bad. Investigation proves a bad relay and a new one is tested and installed in place of the original. This replacement relay actually could be retested before the end of the year 2016 (clock-reset) and not be out of compliance. This requires tracking maintenance by individual relays and is allowed. However, many companies schedule maintenance in other ways like by substation or by circuit breaker or by relay scheme. By these methods of tracking maintenance that “replaced relay” will be retested before the end of the year 2015. This is also acceptable. In no case was a particular relay tested beyond the PSMP of four years max, nor was the 6 year max of the Standard exceeded. The entity can reset the clock if they desire or the entity can continue with original schedules and, in effect, test even more frequently.

Why are batteries excluded from PBM? What about exclusion of batteries from condition based maintenance?

Batteries are the only element of a Protection System that is a perishable item with a shelf life. As a perishable item batteries require not only a constant float charge to maintain their freshness (charge), but periodic inspection to determine if there are problems associated with their aging process and testing to see if they are maintaining a charge or can still deliver their rated output as required.

Besides being perishable, a second unique feature of a battery that is unlike any other Protection System element, is that a battery uses chemicals, metal alloys, plastics, welds, and bonds that must interact with each other to produce the constant dc source required for Protection Systems, undisturbed by ac system Disturbances.

No type of battery manufactured today for Protection System application is free from problems of the sort that can only be detected over time by inspection and test. These problems can arise from variances in the manufacturing process, chemicals and alloys used in the construction of the individual cells, quality of welds and bonds to connect the components, the plastics used to make batteries, and the cell forming process for the individual battery cells.

Other problems that require periodic inspection and testing can result from transportation from the factory to the job site, length of time before a charge is put on the battery, the method of installation, the voltage level and duration of equalize charges, the float voltage level used, and the environment that the battery is installed in.

All of the above mentioned factors, as well as several more not discussed here, are beyond the control of the Functional Entities that want to use a Performance-Based Protection System Maintenance (PBM) program. Inherent variances in the aging process of a battery cell make establishment of a designated segment based on manufacturer and type of battery impossible.

The whole point of PBM is that if all variables are isolated then common aging and performance criteria would be the same. However, there are too many variables in the electrochemical process to completely isolate all of the performance-changing criteria.

Similarly, Functional Entities that want to establish a condition-based maintenance program using the highest levels of monitoring, resulting in the least amount of hands-on maintenance activity, cannot completely eliminate some periodic maintenance of the battery used in a station dc supply. Inspection of the battery is required on a Maximum Maintenance Interval listed in the tables due to the aging processes of station batteries. However, higher degrees of

monitoring of a battery can eliminate the requirement for some periodic testing and some inspections (see Table 1-4).

Please provide an example of the calculations involved in extending maintenance time intervals using PBM.

Entity has 1000 GE-HEA lock-out relays; this is greater than the minimum sample requirement of 60. They start out testing all of the relays within the prescribed Table requirements (6 year max) by testing the relays every 5 years. The entity's plan is to test 200 units per year; this is greater than the minimum sample size requirement of 30. For the sake of example only the following will show 6 failures per year, reality may well have different numbers of failures every year. PBM requires annual assessment of failures found per units tested. After the first year of tests the entity finds 6 failures in the 200 units tested. $6/200 = 3\%$ failure rate. This entity is now allowed to extend the maintenance interval if they choose. The entity chooses to extend the maintenance interval of this population segment out to 10 years. This represents a rate of 100 units tested per year; entity selects 100 units to be tested in the following year. After that year of testing these 100 units the entity again finds 6 failed units. $6/100 = 6\%$ failures. This entity has now exceeded the acceptable failure rate for these devices and must accelerate testing of all of the units at a higher rate such that the failure rate is found to be less than 4% per year; the entity has three years to get this failure rate down to 4% or less (per year). In response to the 6% failure rate, the entity decreases the testing interval to 8 years. This means that they will now test 125 units per year ($1000/8$). The entity has just two years left to get the test rate corrected.

After a year, they again find six failures out of the 125 units tested. $6/125 = 5\%$ failures. In response to the 5% failure rate, the entity decreases the testing interval to seven years. This means that they will now test 143 units per year ($1000/7$). The entity has just one year left to get the test rate corrected. After a year, they again find six failures out of the 143 units tested. $6/143 = 4.2\%$ failures.

(Note that the entity has tried five years and they were under the 4% limit and they tried seven years and they were over the 4% limit. They must be back at 4% failures or less in the next year so they might simply elect to go back to five years.)

Instead, in response to the 5% failure rate, the entity decreases the testing interval to six years. This means that they will now test 167 units per year ($1000/6$). After a year, they again find six failures out of the 167 units tested. $6/167 = 3.6\%$ failures. Entity found that they could maintain the failure rate at no more than 4% failures by maintaining the testing interval at six years or less. Entity chose six-year interval and effectively extended their TBM (five years) program by 20%.

A note of practicality is that an entity will probably be in better shape to lengthen the intervals between tests if the failure rate is less than 2%. But the requirements allow for annual adjustments, if the entity desires. As a matter of maintenance management, an ever-changing test rate (units tested/year) may be un-workable.

Note that the "5% of components" requirement effectively sets a practical limit of 20 year maximum PBM interval. Also of note is the "3 years" requirement; an entity might arbitrarily extend time intervals from six years to 20 years. In the event that an entity finds a failure rate greater than 4%, then the test rate must be accelerated such that within three years the failure rate must be brought back down to 4% or less.

Here is a table that demonstrates the values discussed:

Year #	Total Population (P)	Test Interval (I)	Units to be Tested (U= P/I)	# of Failures Found (F)	Failure Rate (=F/U)	Decision to Change Interval Yes or No	Interval Chosen
1	1000	5 yrs	200	6	3%	Yes	10 yrs
2	1000	10 yrs	100	6	6%	Yes	8 yrs
3	1000	8 yrs	125	6	5%	Yes	7 yrs
4	1000	7 yrs	143	6	4.2%	Yes	6 yrs
5	1000	6 yrs	167	6	3.6%	No	6 yrs

Please provide an example of the calculations involved in extending maintenance time intervals using PBM for control circuitry.

Note that the following example captures “Control Circuitry” as all of the trip paths associated with a particular trip coil of a circuit breaker. An entity is not restricted to this method of counting control circuits. Perhaps another method an entity would prefer would be to simply track every individual (parallel) trip path. Or perhaps another method would be to track all of the trip outputs from a specific (set) of relays protecting a specific element.

The designation of what constitutes a control circuit component is very dependent upon how an entity performs and tracks the testing of the control circuitry. Some entities test their control circuits on a breaker basis whereas others test their circuitry on a local zone of protection basis. Thus, entities are allowed the latitude to designate their own definitions of control circuit components. Another example of where the entity has some discretion on determining what constitutes a single component is the voltage and current sensing devices, where the entity may choose either to designate a full three-phase set of such devices or a single device as a single component.

In Attachment A (PBM) the definition of Segment is:

Segment –*Components of a consistent design standard, or a particular model or type from a single manufacturer that typically share other common elements. Consistent performance is expected across the entire population of a segment. A segment must contain at least sixty (60) individual components.*

Example:

Entity has 1,000 circuit breakers, all of which have two trip coils, for a total of 2,000 trip coils; if all circuitry was designed and built with a consistent (internal entity) standard, then this is greater than the minimum sample requirement of 60.

For the sake of further example, the following facts are given:

Half of all relay panels (500) were built 40 years ago by an outside contractor, consisted of asbestos wrapped 600V-insulation panel wiring, and the cables exiting the control house are

THHN pulled in conduit direct to exactly half of all of the various circuit breakers. All of the relay panels and cable pulls were built with consistent standards and consistent performance standard expectations within the segment (which is greater than 60). Each relay panel has redundant microprocessor (MPC) relays (retrofitted); each MPC relay supplies an individual trip output to each of the two trip coils of the assigned circuit breaker.

Approximately 35 years ago, the entity developed their own internal construction crew and now builds all of their own relay panels from parts supplied from vendors that meet the entity's specifications, including SIS 600V insulation wiring and copper-sheathed cabling within the direct conduits to circuit breakers. The construction crew uses consistent standards in the construction. This newer segment of their control circuitry population is different than the original segment, consistent (standards, construction and performance expectations) within the new segment and constitutes the remainder of the entity's population (another 500 panels and the cabling to the remaining 500 circuit breakers). Each relay panel has redundant microprocessor (MPC) relays; each MPC relay supplies an individual trip output to each of the two trip coils of the assigned circuit breaker. Every trip path in this newer segment has a device that monitors the voltage directly across the trip contacts of the MPC relays and alarms via RTU and SCADA to the operations control room. This monitoring device, when not in alarm, demonstrates continuity all the way through the trip coil, cabling and wiring back to the trip contacts of the MPC relay.

The entity is tracking 2,000 trip coils (each consisting of multiple trip paths) in each of these two segments. But half of all of the trip paths are monitored; therefore, the trip paths are continuously tested and the circuit will alarm when there is a failure. These alarms have to be verified every 12 years for correct operation.

The entity now has 1,000 trip coils (and associated trip paths) remaining that they have elected to count as control circuits. The entity has instituted a process that requires the verification of every trip path to each trip coil (one unit), including the electrical activation of the trip coil. (The entity notes that the trip coils will have to be tripped electrically more often than the trip path verification, and is taking care of this activity through other documentation of Real-time Fault operations.)

They start out testing all of the trip coil circuits within the prescribed Table requirements (12-year max) by testing the trip circuits every 10 years. The entity's plan is to test 100 units per year; this is greater than the minimum sample size requirement of 30. For the sake of example only, the following will show three failures per year; reality may well have different numbers of failures every year. PBM requires annual assessment of failures found per units tested. After the first year of tests, the entity finds three failures in the 100 units tested. $3/100 = 3\%$ failure rate.

This entity is now allowed to extend the maintenance interval, if they choose. The entity chooses to extend the maintenance interval of this population segment out to 20 years. This represents a rate of 50 units tested per year; entity selects 50 units to be tested in the following year. After that year of testing these 50 units, the entity again finds three failed units. $3/50 = 6\%$ failures.

This entity has now exceeded the acceptable failure rate for these devices and must accelerate testing of all of the units at a higher rate, such that the failure rate is found to be less than 4% per year; the entity has three years to get this failure rate down to 4% or less (per year).

In response to the 6% failure rate, the entity decreases the testing interval to 16 years. This means that they will now test 63 units per year ($1000/16$). The entity has just two years left to get the

test rate corrected. After a year, they again find three failures out of the 63 units tested. $3/63 = 4.76\%$ failures.

In response to the $>4\%$ failure rate, the entity decreases the testing interval to 14 years. This means that they will now test 72 units per year ($1000/14$). The entity has just one year left to get the test rate corrected. After a year, they again find three failures out of the 72 units tested. $3/72 = 4.2\%$ failures.

(Note that the entity has tried 10 years, and they were under the 4% limit; and they tried 14 years, and they were over the 4% limit. They must be back at 4% failures or less in the next year, so they might simply elect to go back to 10 years.)

Instead, in response to the 4.2% failure rate, the entity decreases the testing interval to 12 years. This means that they will now test 84 units per year ($1000/12$). After a year, they again find three failures out of the 84 units tested. $3/84 = 3.6\%$ failures.

Entity found that they could maintain the failure rate at no more than 4% failures by maintaining the testing interval at 12 years or less. Entity chose 12-year interval, and effectively extended their TBM (10 years) program by 20%.

A note of practicality is that an entity will probably be in better shape to lengthen the intervals between tests if the failure rate is less than 2%. But the requirements allow for annual adjustments if the entity desires. As a matter of maintenance management, an ever-changing test rate (units tested / year) may be un-workable.

Note that the “5% of components” requirement effectively sets a practical limit of 20-year maximum PBM interval. Also of note is the “3 years” requirement; an entity might arbitrarily extend time intervals from six years to 20 years. In the event that an entity finds a failure rate greater than 4%, then the test rate must be accelerated such that within three years the failure rate must be brought back down to 4% or less.

Here is a table that demonstrates the values discussed:

Year #	Total Population (P)	Test Interval (I)	Units to be Tested (U= P/I)	# of Failures Found (F)	Failure Rate (=F/U)	Decision to Change Interval Yes or No	Interval Chosen
1	1000	10 yrs	100	3	3%	Yes	20 yrs
2	1000	20 yrs	50	3	6%	Yes	16yrs
3	1000	16 yrs	63	3	4.8%	Yes	14 yrs
4	1000	14 yrs	72	3	4.2%	Yes	12 yrs
5	1000	12 yrs	84	3	3.6%	No	12 yrs

Please provide an example of the calculations involved in extending maintenance time intervals using PBM for voltage and current sensing devices.

Note that the following example captures “voltage and current inputs to the protective relays” as all of the various current transformer and potential transformer signals associated with a particular set of relays used for protection of a specific Element. This entity calls this set of protective relays a “Relay Scheme.” Thus, this entity chooses to count PT and CT signals as a group instead of individually tracking maintenance activities to specific bushing CT’s or specific PT’s. An entity is not restricted to this method of counting voltage and current devices, signals and paths. Perhaps another method an entity would prefer would be to simply track every individual PT and CT. Note that a generation maintenance group may well select the latter because they may elect to perform routine off-line tests during generator outages, whereas a transmission maintenance group might create a process that utilizes Real-time system values measured at the relays.

The designation of what constitutes a control circuit component is very dependent upon how an entity performs and tracks the testing of the control circuitry. Some entities test their control circuits on a breaker basis whereas others test their circuitry on a local zone of protection basis. Thus, entities are allowed the latitude to designate their own definitions of control circuit components. Another example of where the entity has some discretion on determining what constitutes a single component is the voltage and current sensing devices, where the entity may choose either to designate a full three-phase set of such devices or a single device as a single component.

And in Attachment A (PBM) the definition of Segment:

Segment –*Components of a consistent design standard, or a particular model or type from a single manufacturer that typically share other common elements. Consistent performance is expected across the entire population of a segment. A segment must contain at least sixty (60) individual components.*

Example:

Entity has 2000 “Relay Schemes,” all of which have three current signals supplied from bushing CTs, and three voltage signals supplied from substation bus PT’s. All cabling and circuitry was designed and built with a consistent (internal entity) standard, and this population is greater than the minimum sample requirement of 60.

For the sake of further example the following facts are given:

Half of all relay schemes (1,000) are supplied with current signals from ANSI STD C800 bushing CTs and voltage signals from PTs built by ACME Electric MFR CO. All of the relay panels and cable pulls were built with consistent standards, and consistent performance standard expectations exist for the consistent wiring, cabling and instrument transformers within the segment (which is greater than 60).

The other half of the entity’s relay schemes have MPC relays with additional monitoring built-in that compare DNP values of voltages and currents (or wWatts and VARsvars), as interpreted by the MPC relays and alarm for an entity-accepted tolerance level of accuracy. This newer segment of their “Voltage and Current Sensing” population is different than the original segment, consistent (standards, construction and performance expectations) within the new segment and constitutes the remainder of the entity’s population.

The entity is tracking many thousands of voltage and current signals within 2,000 relay schemes (each consisting of multiple voltage and current signals) in each of these two segments. But half of all of the relay schemes voltage and current signals are monitored; therefore, the voltage and current signals are continuously tested and the circuit will alarm when there is a failure; these alarms have to be verified every 12 years for correct operation.

The entity now has 1,000 relay schemes worth of voltage and current signals remaining that they have elected to count within their relay schemes designation. The entity has instituted a process that requires the verification of these voltage and current signals within each relay scheme (one unit).

(Please note - a problem discovered with a current or voltage signal found at the relay could be caused by anything from the relay, all the way to the signal source itself. Having many sources of problems can easily increase failure rates beyond the rate of failures of just one item (for example just PTs). It is the intent of the SDT to minimize failure rates of all of the equipment to an acceptable level; thus, any failure of any item that gets the signal from source to relay is counted. It is for this reason that the SDT chose to set the boundary at the ability of the signal to be delivered all the way to the relay.

The entity will start out measuring all of the relay scheme voltage and currents at the individual relays within the prescribed Table requirements (12 year max) by measuring the voltage and current values every 10 years. The entity's plan is to test 100 units per year; this is greater than the minimum sample size requirement of 30. For the sake of example only, the following will show three failures per year; reality may well have different numbers of failures every year. PBM requires annual assessment of failures found per units tested. After the first year of tests, the entity finds three failures in the 100 units tested. $3/100 = 3\%$ failure rate.

This entity is now allowed to extend the maintenance interval, if they choose. The entity chooses to extend the maintenance interval of this population segment out to 20 years. This represents a rate of 50 units tested per year; entity selects 50 units to be tested in the following year. After that year of testing these 50 units, the entity again finds three failed units. $3/50 = 6\%$ failures.

This entity has now exceeded the acceptable failure rate for these devices and must accelerate testing of all of the units at a higher rate, such that the failure rate is found to be less than 4% per year; the entity has three years to get this failure rate down to 4% or less (per year).

In response to the 6% failure rate, the entity decreases the testing interval to 16 years. This means that they will now test 63 units per year ($1000/16$). The entity has just two years left to get the test rate corrected. After a year, they again find three failures out of the 63 units tested. $3/63 = 4.76\%$ failures.

In response to the >4% failure rate, the entity decreases the testing interval to 14 years. This means that they will now test 72 units per year ($1000/14$). The entity has just one year left to get the test rate corrected. After a year, they again find three failures out of the 72 units tested. $3/72 = 4.2\%$ failures.

(Note that the entity has tried 10 years, and they were under the 4% limit; and they tried 14 years, and they were over the 4% limit. They must be back at 4% failures or less in the next year, so they might simply elect to go back to 10 years.)

Instead, in response to the 4.2% failure rate, the entity decreases the testing interval to 12 years. This means that they will now test 84 units per year (1,000/12). After a year, they again find three failures out of the 84 units tested. $3/84 = 3.6\%$ failures.

Entity found that they could maintain the failure rate at no more than 4% failures by maintaining the testing interval at 12 years or less. Entity chose 12-year interval and effectively extended their TBM (10 years) program by 20%.

A note of practicality is that an entity will probably be in better shape to lengthen the intervals between tests if the failure rate is less than 2%. But the requirements allow for annual adjustments, if the entity desires. As a matter of maintenance management, an ever-changing test rate (units tested/year) may be un-workable.

Note that the “5% of components” requirement effectively sets a practical limit of 20-year maximum PBM interval. Also of note is the “3 years” requirement; an entity might arbitrarily extend time intervals from six years to 20 years. In the event that an entity finds a failure rate greater than 4%, then the test rate must be accelerated such that within three years the failure rate must be brought back down to 4% or less.

Here is a table that demonstrates the values discussed:

Year #	Total Population (P)	Test Interval (I)	Units to be Tested (U= P/I)	# of Failures Found (F)	Failure Rate (=F/U)	Decision to Change Interval Yes or No	Interval Chose
1	1000	10 yrs	100	3	3%	Yes	20 yrs
2	1000	20 yrs	50	3	6%	Yes	16yrs
3	1000	16 yrs	63	3	4.8%	Yes	14 yrs
4	1000	14 yrs	72	3	4.2%	Yes	12 yrs
5	1000	12 yrs	84	3	3.6%	No	12 yrs

10. Overlapping the Verification of Sections of the Protection System

Tables 1-1 through 1-5 require that every Protection System component be periodically verified. One approach, but not the only method, is to test the entire protection scheme as a unit, from the secondary windings of voltage and current sources to breaker tripping. For practical ongoing verification, sections of the Protection System may be tested or monitored individually. The boundaries of the verified sections must overlap to ensure that there are no gaps in the verification. See Appendix A of this Supplementary Reference for additional discussion on this topic.

All of the methodologies expressed within this report may be combined by an entity, as appropriate, to establish and operate a maintenance program. For example, a Protection System may be divided into multiple overlapping sections with a different maintenance methodology for each section:

- Time-based maintenance with appropriate maximum verification intervals for categories of equipment, as given in the Tables 1-1 through 1-5;
- Monitoring as described in Tables 1-1 through 1-5;
- A Performance-Based Maintenance program as described in Section 9 above, or Attachment A of the standard;
- Opportunistic verification using analysis of Fault records, as described in Section 11

10.1 Frequently Asked Questions:

My system has alarms that are gathered once daily through an auto-polling system; this is not really a conventional SCADA system but does it meet the Table 1 requirements for inclusion as a monitored system?

Yes--provided the auto-polling that gathers the alarms reports those alarms to a location where the action can be initiated to correct the Unresolved Maintenance Issue. This location does not have to be the location of the engineer or the technician that will eventually repair the problem, but rather a location where the action can be initiated.

11. Monitoring by Analysis of Fault Records

Many users of microprocessor relays retrieve Fault event records and oscillographic records by data communications after a Fault. They analyze the data closely if there has been an apparent Misoperation, as NERC standards require. Some advanced users have commissioned automatic Fault record processing systems that gather and archive the data. They search for evidence of component failures or setting problems hidden behind an operation whose overall outcome seems to be correct. The relay data may be augmented with independently captured Digital Fault Recorder (DFR) data retrieved for the same event.

Fault data analysis comprises a legitimate CBM program that is capable of reducing the need for a manual time-interval based check on Protection Systems whose operations are analyzed. Even electromechanical Protection Systems instrumented with DFR channels may achieve some CBM benefit. The completeness of the verification then depends on the number and variety of Faults in the vicinity of the relay that produce relay response records and the specific data captured.

A typical Fault record will verify particular parts of certain Protection Systems in the vicinity of the Fault. For a given Protection System installation, it may or may not be possible to gather within a reasonable amount of time an ensemble of internal and external Fault records that completely verify the Protection System.

For example, Fault records may verify that the particular relays that tripped are able to trip via the control circuit path that was specifically used to clear that Fault. A relay or DFR record may indicate correct operation of the protection communications channel. Furthermore, other nearby Protection Systems may verify that they restrain from tripping for a Fault just outside their respective zones of protection. The ensemble of internal Fault and nearby external Fault event data can verify major portions of the Protection System, and reset the time clock for the Table 1 testing intervals for the verified components only.

What can be shown from the records of one operation is very specific and limited. In a panel with multiple relays, only the specific relay(s) whose operation can be observed without ambiguity should be used. Be careful about using Fault response data to verify that settings or calibration are correct. Unless records have been captured for multiple Faults close to either side of a setting boundary, setting or calibration could still be incorrect.

PMU data, much like DME data, can be utilized to prove various components of the Protection System. Obviously, care must be taken to attribute proof only to the parts of a Protection System that can actually be proven using the PMU or DME data.

If Fault record data is used to show that portions or all of a Protection System have been verified to meet Table 1 requirements, the owner must retain the Fault records used, and the maintenance-related conclusions drawn from this data and used to defer Table 1 tests, for at least the retention time interval given in Section 8.2.

11.1 Frequently Asked Questions:

I use my protective relays for Fault and Disturbance recording, collecting oscillographic records and event records via communications for Fault analysis to meet NERC and DME requirements. What are the maintenance requirements for the relays?

For relays used only as Disturbance Monitoring Equipment, NERC Standard PRC-018-1 R3 & R6 states the maintenance requirements and is being addressed by a standards activity that is revising PRC-002-1 and PRC-018-1. For protective relays “that are designed to provide protection for the BES,” this standard applies, even if they also perform DME functions.

12. Importance of Relay Settings in Maintenance Programs

In manual testing programs, many utilities depend on pickup value or zone boundary tests to show that the relays have correct settings and calibration. Microprocessor relays, by contrast, provide the means for continuously monitoring measurement accuracy. Furthermore, the relay digitizes inputs from one set of signals to perform all measurement functions in a single self-monitoring microprocessor system. These relays do not require testing or calibration of each setting.

However, incorrect settings may be a bigger risk with microprocessor relays than with older relays. Some microprocessor relays have hundreds or thousands of settings, many of which are critical to Protection System performance.

Monitoring does not check measuring element settings. Analysis of Fault records may or may not reveal setting problems. To minimize risk of setting errors after commissioning, the user should enforce strict settings data base management, with reconfirmation (manual or automatic) that the installed settings are correct whenever maintenance activity might have changed them; for background and guidance, see [5] in References.

Table 1 requires that settings must be verified to be as specified. The reason for this requirement is simple: With legacy relays (non-microprocessor protective relays), it is necessary to know the value of the intended setting in order to test, adjust and calibrate the relay. Proving that the relay works per specified setting was the de facto procedure. However, with the advanced microprocessor relays, it is possible to change relay settings for the purpose of verifying specific functions and then neglect to return the settings to the specified values. While there is no specific requirement to maintain a settings management process, there remains a need to verify that the settings left in the relay are the intended, specified settings. This need may manifest itself after any of the following:

- One or more settings are changed for any reason.
- A relay fails and is repaired or replaced with another unit.
- A relay is upgraded with a new firmware version.

12.1 Frequently Asked Questions:

How do I approach testing when I have to upgrade firmware of a microprocessor relay?

The entity should ensure that the relay continues to function properly after implementation of firmware changes. Some entities may have a Research and Development (R&D) department that might routinely run acceptance tests on devices with firmware upgrades before allowing the upgrade to be installed. Other entities may rely upon the vigorous testing of the firmware OEM. An entity has the latitude to install devices and/or programming that they believe will perform to their satisfaction. If an entity should choose to perform the maintenance activities specified in the Tables following a firmware upgrade, then they may, if they choose, reset the time clock on that set of maintenance activities so that they would not have to repeat the maintenance on

its regularly scheduled cycle. (However, for simplicity in maintenance schedules, some entities may choose to not reset this time clock; it is merely a suggested option.)

If I upgrade my old relays, then do I have to maintain my previous equipment maintenance documentation?

If an equipment item is repaired or replaced, then the entity can restart the maintenance-activity-time-interval-clock, if desired; however, the replacement of equipment does not remove any documentation requirements. The requirements in the standard are intended to ensure that an entity has a maintenance plan, and that the entity adheres to minimum activities and maximum time intervals. The documentation requirements are intended to help an entity demonstrate compliance. For example, saving the dates and records of the last two maintenance activities is intended to demonstrate compliance with the interval. Therefore, if you upgrade or replace equipment, then you still must maintain the documentation for the previous equipment, thus demonstrating compliance with the time interval requirement prior to the replacement action.

We have a number of installations where we have changed our Protection System components. Some of the changes were upgrades, but others were simply system rating changes that merely required taking relays “out-of-service”. What are our responsibilities when it comes to “out-of-service” devices?

Assuming that your system up-rates, upgrades and overall changes meet any and all other requirements and standards, then the requirements of PRC-005-6 are simple – if the Protection System component performs a Protection System function, then it must be maintained. If the component no longer performs Protection System functions, then it does not require maintenance activities under the Tables of PRC-005-6. While many entities might physically remove a component that is no longer needed, there is no requirement in PRC-005-6 to remove such component(s). Obviously, prudence would dictate that an “out-of-service” device is truly made inactive. There are no record requirements listed in PRC-005-6 for Protection System components not used.

While performing relay testing of a protective device on our Bulk Electric System, it was discovered that the protective device being tested was either broken or out of calibration. Does this satisfy the relay testing requirement, even though the protective device tested bad, and may be unable to be placed back into service?

Yes, PRC-005-6 requires entities to perform relay testing on protective devices on a given maintenance cycle interval. By performing this testing, the entity has satisfied PRC-005-6 requirement, although the protective device may be unable to be returned to service under normal calibration adjustments. Requirement R5 states:

“R5. Each Transmission Owner, Generator Owner, and Distribution Provider shall demonstrate efforts to correct any identified Unresolved Maintenance Issues.”

Also, when a failure occurs in a Protection System, power system security may be comprised, and notification of the failure must be conducted in accordance with relevant NERC standards.

If I show the protective device out of service while it is being repaired, then can I add it back as a new protective device when it returns? If not, my relay testing history would show that I was out of compliance for the last maintenance cycle.

The maintenance and testing requirements (Requirement R5) state “...shall demonstrate efforts to correct any identified Unresolved Maintenance Issues...” The type of corrective activity is not stated; however, it could include repairs or replacements.

Your documentation requirements will increase, of course, to demonstrate that your device tested bad and had corrective actions initiated. Your regional entity might ask about the status of your corrective actions.

13. Self-Monitoring Capabilities and Limitations

Microprocessor relay proponents have cited the self-monitoring capabilities of these products for nearly 20 years. Theoretically, any element that is monitored does not need a periodic manual test. A problem today is that the community of manufacturers and users has not created clear documentation of exactly what is and is not monitored. Some unmonitored but critical elements are buried in installed systems that are described as self-monitoring.

To utilize the extended time intervals allowed by monitoring, the user must document that the monitoring attributes of the device match the minimum requirements listed in the Table 1.

Until users are able to document how all parts of a system which are required for the protective functions are monitored or verified (with help from manufacturers), they must continue with the unmonitored intervals established in Tables 1, 3, 4 and 5 and any associated sub-tables.

Going forward, manufacturers and users can develop mappings of the monitoring within relays, and monitoring coverage by the relay of user circuits connected to the relay terminals.

To enable the use of the most extensive monitoring (and never again have a hands-on maintenance requirement), the manufacturers of the microprocessor-based self-monitoring components in the Protection System should publish for the user a document or map that shows:

- How all internal elements of the product are monitored for any failure that could impact Protection System performance.
- Which connected circuits are monitored by checks implemented within the product; how to connect and set the product to assure monitoring of these connected circuits; and what circuits or potential problems are not monitored.

This manufacturer's information can be used by the registered entity to document compliance of the monitoring attributes requirements by:

- Presenting or referencing the product manufacturer's documents.
- Explaining in a system design document the mapping of how every component and circuit that is critical to protection is monitored by the microprocessor product(s) or by other design features.
- Extending the monitoring to include the alarm transmission Facilities through which failures are reported within a given time frame to allocate where action can be taken to initiate resolution of the alarm attributed to an Unresolved Maintenance Issue, so that failures of monitoring or alarming systems also lead to alarms and action.
- Documenting the plans for verification of any unmonitored components according to the requirements of Tables 1, 3, 4 and 5 and any associated sub-tables.

13.1 Frequently Asked Questions:

I can't figure out how to demonstrate compliance with the requirements for the highest level of monitoring of Protection Systems. Why does this Maintenance Standard describe a maintenance program approach I cannot achieve?

Demonstrating compliance with the requirements for the highest level of monitoring any particular component of Protection Systems is likely to be very involved, and may include detailed manufacturer documentation of complete internal monitoring within a device, comprehensive design drawing reviews, and other detailed documentation. This standard does not presume to specify what documentation must be developed; only that it must be documented.

There may actually be some equipment available that is capable of meeting these highest levels of monitoring criteria, in which case it may be maintained according to the highest level of monitoring shown on the Tables. However, even if there is no equipment available today that can meet this level of monitoring, the standard establishes the necessary requirements for when such equipment becomes available.

By creating a roadmap for development, this provision makes the standard technology-neutral. The Standard Drafting Team wants to avoid the need to revise the standard in a few years to accommodate technology advances that may be coming to the industry.

14. Notification of Protection System or Automatic Reclosing Failures

When a failure occurs in a Protection System or Automatic Reclosing, power system security may be compromised, and notification of the failure must be conducted in accordance with relevant NERC standard(s). Knowledge of the failure may impact the system operator's decisions on acceptable Loading conditions.

This formal reporting of the failure and repair status to the system operator by the Protection System or Automatic Reclosing owner also encourages the system owner to execute repairs as rapidly as possible. In some cases, a microprocessor relay or carrier set can be replaced in hours; wiring termination failures may be repaired in a similar time frame. On the other hand, a component in an electromechanical or early-generation electronic relay may be difficult to find and may hold up repair for weeks. In some situations, the owner may have to resort to a temporary protection panel, or complete panel replacement.

15. Maintenance Activities

Some specific maintenance activities are a requirement to ensure reliability. An example would be that a BES entity could be prudent in its protective relay maintenance, but if its battery maintenance program is lacking, then reliability could still suffer. The NERC glossary outlines a Protection System as containing specific components. PRC-005-6 requires specific maintenance activities be accomplished within a specific time interval. As noted previously, higher technology equipment can contain integral monitoring capability that actually performs maintenance verification activities routinely and often; therefore, *manual intervention* to perform certain activities on these type components may not be needed.

15.1 Protective Relays (Table 1-1)

These relays are defined as the devices that receive the input signal from the current and voltage sensing devices and are used to isolate a Faulted Element of the BES. Devices that sense thermal, vibration, seismic, gas, or any other non-electrical inputs are excluded.

Non-microprocessor based equipment is treated differently than microprocessor-based equipment in the following ways; the relays should meet the asset owners' tolerances:

- Non-microprocessor devices must be tested with voltage and/or current applied to the device.
- Microprocessor devices may be tested through the integral testing of the device.
 - There is no specific protective relay commissioning test or relay routine test mandated.
 - There is no specific documentation mandated.

15.1.1 Frequently Asked Questions:

What calibration tolerance should be applied on electromechanical relays?

Each entity establishes their own acceptable tolerances when applying protective relaying on their system. For some Protection System components, adjustment is required to bring measurement accuracy within the parameters established by the asset owner based on the specific application of the component. A calibration failure is the result if testing finds the specified parameters to be out of tolerance.

15.2 Voltage & Current Sensing Devices (Table 1-3)

These are the current and voltage sensing devices, usually known as instrument transformers. There is presently a technology available (fiber-optic Hall-effect) that does not utilize conventional transformer technology; these devices and other technologies that produce quantities that represent the primary values of voltage and current are considered to be a type of voltage and current sensing devices included in this standard.

The intent of the maintenance activity is to verify the input to the protective relay from the device that produces the current or voltage signal sample.

There is no specific test mandated for these components. The important thing about these signals is to know that the expected output from these components actually reaches the protective relay. Therefore, the proof of the proper operation of these components also demonstrates the integrity of the wiring (or other medium used to convey the signal) from the current and voltage sensing device, all the way to the protective relay. The following observations apply:

- There is no specific ratio test, routine test or commissioning test mandated.
- There is no specific documentation mandated.
- It is required that the signal be present at the relay.
- This expectation can be arrived at from any of a number of means; including, but not limited to, the following: By calculation, by comparison to other circuits, by commissioning tests, by thorough inspection, or by any means needed to verify the circuit meets the asset owner's Protection System maintenance program.
- An example of testing might be a saturation test of a CT with the test values applied at the relay panel; this, therefore, tests the CT, as well as the wiring from the relay all the back to the CT.
- Another possible test is to measure the signal from the voltage and/or current sensing devices, during Load conditions, at the input to the relay.
- Another example of testing the various voltage and/or current sensing devices is to query the microprocessor relay for the Real-time Loading; this can then be compared to other devices to verify the quantities applied to this relay. Since the input devices have supplied the proper values to the protective relay, then the verification activity has been satisfied. Thus, event reports (and oscillographs) can be used to verify that the voltage and current sensing devices are performing satisfactorily.
- Still another method is to measure total watts and vars around the entire bus; this should add up to zero watts and zero vars, thus proving the voltage and/or current sensing devices system throughout the bus.
- Another method for proving the voltage and/or current-sensing devices is to complete commissioning tests on all of the transformers, cabling, fuses and wiring.
- Any other method that verifies the input to the protective relay from the device that produces the current or voltage signal sample.

15.2.1 Frequently Asked Questions:

What is meant by "...verify the current and voltage circuit inputs from the voltage and current sensing devices to the protective relays ..." Do we need to perform ratio, polarity and saturation tests every few years?

No--you must verify that the protective relay is receiving the expected values from the voltage and current-sensing devices (typically voltage and current transformers). This can be as difficult as is proposed by the question (with additional testing on the cabling and substation wiring to ensure that the values arrive at the relays); or simplicity can be achieved by other verification methods. While some examples follow, these are not intended to represent an all-inclusive list; technology advances and ingenuity should not be excluded from making comparisons and verifications:

- Compare the secondary values, at the relay, to a metering circuit, fed by different current transformers, monitoring the same line as the questioned relay circuit.
- Compare the individual phase secondary values at the relay panel (with additional testing on the panel wiring to ensure that the values arrive at those relays) with the other phases, and verify that residual currents are within expected bounds.
- Observe all three phase currents and the residual current at the relay panel with an oscilloscope, observing comparable magnitudes and proper phase relationship, with additional testing on the panel wiring to ensure that the values arrive at the relays.
- Compare the values, as determined by the questioned relay (such as, but not limited to, a query to the microprocessor relay) to another protective relay monitoring the same line, with currents supplied by different CTs.
- Compare the secondary values, at the relay with values measured by test instruments (such as, but not limited to multi-meters, voltmeter, clamp-on ammeters, etc.) and verified by calculations and known ratios to be the values expected. For example, a single PT on a 100 KV bus will have a specific secondary value that, when multiplied by the PT ratio, arrives at the expected bus value of 100 KV.
- Query SCADA for the power flows at the far end of the line protected by the questioned relay, compare those SCADA values to the values as determined by the questioned relay.
- Totalize the Watts-watts and vars on the bus and compare the totals to the values as seen by the questioned relay.

The point of the verification procedure is to ensure that all of the individual components are functioning properly; and that an ongoing proactive procedure is in place to re-check the various components of the protective relay measuring Systems.

Is wiring insulation or hi-pot testing required by this Maintenance Standard?

No--wiring insulation and equipment hi-pot testing are not specifically required by the Maintenance Standard. However, if the method of verifying CT and PT inputs to the relay involves some other method than actual observation of current and voltage transformer secondary inputs to the relay, it might be necessary to perform some sort of cable integrity test to verify that the instrument transformer secondary signals are actually making it to the relay and not being shunted off to ground. For instance, you could use CT excitation tests and PT turns ratio tests

and compare to baseline values to verify that the instrument transformer outputs are acceptable. However, to conclude that these acceptable transformer instrument output signals are actually making it to the relay inputs, it also would be necessary to verify the insulation of the wiring between the instrument transformer and the relay.

My plant generator and transformer relays are electromechanical and do not have metering functions, as do microprocessor-based relays. In order for me to compare the instrument transformer inputs to these relays to the secondary values of other metered instrument transformers monitoring the same primary voltage and current signals, it would be necessary to temporarily connect test equipment, like voltmeters and clamp on ammeters, to measure the input signals to the relays. This practice seems very risky, and a plant trip could result if the technician were to make an error while measuring these current and voltage signals. How can I avoid this risk? Also, what if no other instrument transformers are available which monitor the same primary voltage or current signal?

Comparing the input signals to the relays to the outputs of other independent instrument transformers monitoring the same primary current or voltage is just one method of verifying the instrument transformer inputs to the relays, but is not required by the standard. Plants can choose how to best manage their risk. If online testing is deemed too risky, offline tests, such as, but not limited to, CT excitation test and PT turns ratio tests can be compared to baseline data and be used in conjunction with CT and PT secondary wiring insulation verification tests to adequately “verify the current and voltage circuit inputs from the voltage and current sensing devices to the protective relays...” while eliminating the risk of tripping an in service generator or transformer. Similarly, this same offline test methodology can be used to verify the relay input voltage and current signals to relays when there are no other instrument transformers monitoring available for purposes of signal comparison.

15.3 Control circuitry associated with protective functions (Table 1-5)

This component of Protection Systems includes the trip coil(s) of the circuit breaker, circuit switcher or any other interrupting device. It includes the wiring from the batteries to the relays. It includes the wiring (or other signal conveyance) from every trip output to every trip coil. It includes any device needed for the correct processing of the needed trip signal to the trip coil of the interrupting device; this requirement is meant to capture inputs and outputs to and from a protective relay that are necessary for the correct operation of the protective functions. In short, every trip path must be verified; the method of verification is optional to the asset owner. An example of testing methods to accomplish this might be to verify, with a volt-meter, the existence of the proper voltage at the open contacts, the open circuited input circuit and at the trip coil(s). As every parallel trip path has similar failure modes, each trip path from relay to trip coil must be verified. Each trip coil must be tested to trip the circuit breaker (or other interrupting device) at least once. There is a requirement to operate the circuit breaker (or other interrupting device) at least once every six years as part of the complete functional test. If a suitable monitoring system is installed that verifies every parallel trip path, then the manual-intervention testing of those parallel trip paths can be eliminated; however, the actual operation of the circuit breaker must still occur at least once every six years. This six-year tripping requirement can be completed as easily as tracking the Real-time Fault-clearing operations on the circuit breaker, or tracking the trip coil(s) operation(s) during circuit breaker routine maintenance actions.

The circuit-interrupting device should not be confused with a motor-operated disconnect. The intent of this standard is to require maintenance intervals and activities on Protection Systems equipment, and not just all system isolating equipment.

It is necessary, however, to classify a device that actuates a high-speed auto-closing ground switch as an interrupting device, if this ground switch is utilized in a Protection System and forces a ground Fault to occur that then results in an expected Protection System operation to clear the forced ground Fault. The SDT believes that this is essentially a transferred-tripping device without the use of communications equipment. If this high-speed ground switch is “...designed to provide protection for the BES...” then this device needs to be treated as any other Protection System component. The control circuitry would have to be tested within 12 years, and any electromechanically operated device will have to be tested every six years. If the spring-operated ground switch can be disconnected from the solenoid triggering unit, then the solenoid triggering unit can easily be tested without the actual closing of the ground blade.

The dc control circuitry also includes each auxiliary tripping relay (94) and each lock-out relay (86) that may exist in any particular trip scheme. If the lock-out relays (86) are electromechanical type components, then they must be trip tested. The PSMT SDT considers these components to share some similarities in failure modes as electromechanical protective relays; as such, there is a six-year maximum interval between mandated maintenance tasks unless PBM is applied.

Contacts of the 86 and/or 94 that pass the trip current on to the circuit interrupting device trip coils will have to be checked as part of the 12 year requirement. Contacts of the 86 and/or 94 lock relay that operate non-BES interrupting devices are not required. Normally-open contacts that are not used to pass a trip signal and normally-closed contacts do not have to be verified. Verification of the tripping paths is the requirement.

New technology is also accommodated here; there are some tripping systems that have replaced the traditional hard-wired trip circuitry with other methods of trip-signal conveyance such as fiber-optics. It is the intent of the PSMT SDT to include this, and any other, technology that is used to convey a trip signal from a protective relay to a circuit breaker (or other interrupting device) within this category of equipment. The requirement for these systems is verification of the tripping path.

Monitoring of the control circuit integrity allows for no maintenance activity on the control circuit (excluding the requirement to operate trip coils and electromechanical lockout and/or tripping auxiliary relays). Monitoring of integrity means to monitor for continuity and/or presence of voltage on each trip path. For Ethernet or fiber-optic control systems, monitoring of integrity means to monitor communication ability between the relay and the circuit breaker.

15.3.1 Frequently Asked Questions:

Is it permissible to verify circuit breaker tripping at a different time (and interval) than when we verify the protective relays and the instrument transformers?

Yes--provided the entire Protective System is tested within the individual component's maximum allowable testing intervals.

The Protection System Maintenance Standard describes requirements for verifying the tripping of circuit breakers. What is this telling me about maintenance of circuit breakers?

Requirements in PRC-005-6 are intended to verify the integrity of tripping circuits, including the breaker trip coil, as well as the presence of auxiliary supply (usually a battery) for energizing the trip coil if a protection function operates. Beyond this, PRC-005-6 sets no requirements for verifying circuit breaker performance, or for maintenance of the circuit breaker.

How do I test each dc Control Circuit trip path, as established in Table 1-5 “Protection System Control Circuitry (Trip coils and auxiliary relays)”?

Table 1-5 specifies that each breaker trip coil and lockout relays that carry trip current to a trip coil must be operated within the specified time period. The required operations may be via targeted maintenance activities, or by documented operation of these devices for other purposes such as Fault clearing.

Are high-speed ground switch trip coils included in the dc control circuitry?

Yes--PRC-005-6 includes high-speed grounding switch trip coils within the dc control circuitry to the degree that the initiating Protection Systems are characterized as “transmission Protection Systems.”

Does the control circuitry and trip coil of a non-BES breaker, tripped via a BES protection component, have to be tested per Table 1.5? (Refer to Table 3 for examples 1 and 2)

Example 1: A non-BES circuit breaker that is tripped via a Protection System to which PRC-005-6 applies might be (but is not limited to) a 12.5KV circuit breaker feeding (non-black-start) radial Loads but has a trip that originates from an under-frequency (81) relay.

- The relay must be verified.
- The voltage signal to the relay must be verified.
- All of the relevant dc supply tests still apply.
- The unmonitored trip circuit between the relay and any lock-out or auxiliary relay must be verified every 12 years.
- The unmonitored trip circuit between the lock-out (or auxiliary relay) and the non-BES breaker does not have to be proven with an electrical trip.
- In the case where there is no lock-out or auxiliary tripping relay used, the trip circuit to the non-BES breaker does not have to be proven with an electrical trip.
- The trip coil of the non-BES circuit breaker does not have to be individually proven with an electrical trip.

Example 2: A Transmission Owner may have a non-BES breaker that is tripped via a Protection System to which PRC-005-6 applies, which may be (but is not limited to) a 13.8 KV circuit breaker feeding (non-black-start) radial Loads but has a trip that originates from a BES 115KV line relay.

- The relay must be verified
- The voltage signal to the relay must be verified
- All of the relevant dc supply tests still apply

- The unmonitored trip circuit between the relay and any lock-out (86) or auxiliary (94) relay must be verified every 12 years
- The unmonitored trip circuit between the lock-out (86) (or auxiliary (94)) relay and the non-BES breaker does not have to be proven with an electrical trip
- In the case where there is no lockout (86) or auxiliary (94) tripping relay used, the trip circuit to the non-BES breaker does not have to be proven with an electrical trip.
- The trip coil of the non-BES circuit breaker does not have to be individually proven with an electrical trip

Example 3: A Generator Owner may have a non-BES circuit breaker that is tripped via a Protection System to which PRC-005-6 applies, such as the generator field breaker and low-side breakers on station service/excitation transformers connected to the generator bus.

Trip testing of the generator field breaker and low side station service/excitation transformer breaker(s) via lockout or auxiliary tripping relays are not required since these breakers may be associated with radially fed loads and are not considered to be BES breakers. An example of an otherwise non-BES circuit breaker that is tripped via a BES protection component might be (but is not limited to) a 6.9kV station service transformer source circuit breaker but has a trip that originates from a generator differential (87) relay.

- The differential relay must be verified.
- The current signals to the relay must be verified.
- All of the relevant dc supply tests still apply.
- The unmonitored trip circuit between the relay and any lock-out or auxiliary relay must be verified every 12 years.
- The unmonitored trip circuit between the lock-out (or auxiliary relay) and the non-BES breaker does not have to be proven with an electrical trip.
- In the case where there is no lock-out or auxiliary tripping relay used, the trip circuit to the non-BES breaker does not have to be proven with an electrical trip.
- The trip coil of the non-BES circuit breaker does not have to be individually proven with an electrical trip.

However, it is very prudent to verify the tripping of such breakers for the integrity of the overall generation plant.

Do I have to verify operation of breaker “a” contacts or any other normally closed auxiliary contacts in the trip path of each breaker as part of my control circuit test?

Operation of normally-closed contacts does not have to be verified. Verification of the tripping paths is the requirement. The continuity of the normally closed contacts will be verified when the tripping path is verified.

15.4 Batteries and DC Supplies (Table 1-4)

The NERC definition of a Protection System is:

- Protective relays which respond to electrical quantities,
- Communications Systems necessary for correct operation of protective functions,

-
- Voltage and current sensing devices providing inputs to protective relays,
 - Station dc supply associated with protective functions (including station batteries, battery chargers, and non-battery-based dc supply), and
 - Control circuitry associated with protective functions through the trip coil(s) of the circuit breakers or other interrupting devices.

The station battery is not the only component that provides dc power to a Protection System. In the new definition for Protection System, “station batteries” are replaced with “station dc supply” to make the battery charger and dc producing stored energy devices (that are not a battery) part of the Protection System that must be maintained.

The PSMT SDT recognizes that there are several technological advances in equipment and testing procedures that allow the owner to choose how to verify that a battery string is free of open circuits. The term “continuity” was introduced into the standard to allow the owner to choose how to verify continuity of a battery set by various methods, and not to limit the owner to other conventional methods of showing continuity. Continuity, as used in Table 1-4 of the standard, refers to verifying that there is a continuous current path from the positive terminal of the station battery set to the negative terminal. Without verifying continuity of a station battery, there is no way to determine that the station battery is available to supply dc power to the station. An open battery string will be an unavailable power source in the event of loss of the battery charger.

Batteries cannot be a unique population segment of a Performance-Based Maintenance Program (PBM) because there are too many variables in the electrochemical process to completely isolate all of the performance-changing criteria necessary for using PBM on battery Systems. However, nothing precludes the use of a PBM process for any other part of a dc supply besides the batteries themselves.

15.4.1 Frequently Asked Questions:

What constitutes the station dc supply, as mentioned in the definition of Protective System?

The previous definition of Protection System includes batteries, but leaves out chargers. The latest definition includes chargers, as well as dc systems that do not utilize batteries. This revision of PRC-005-6 is intended to capture these devices that were not included under the previous definition. The station direct current (dc) supply normally consists of two components: the battery charger and the station battery itself. There are also emerging technologies that provide a source of dc supply that does not include either a battery or charger.

Battery Charger - The battery charger is supplied by an available ac source. At a minimum, the battery charger must be sized to charge the battery (after discharge) and supply the constant dc load. In many cases, it may be sized also to provide sufficient dc current to handle the higher energy requirements of tripping breakers and switches when actuated by the protective relays in the Protection System.

Station Battery - Station batteries provide the dc power required for tripping and for supplying normal dc power to the station in the event of loss of the battery charger. There are several technologies of battery that require unique forms of maintenance as established in Table 1-4.

Emerging Technologies - Station dc supplies are currently being developed that use other energy storage technologies besides the station battery to prevent loss of the station dc supply when ac power is lost. Maintenance of these station dc supplies will require different kinds of tests and inspections. Table 1-4 presents maintenance activities and maximum allowable testing intervals for these new station dc supply technologies. However, because these technologies are relatively new, the maintenance activities for these station dc supplies may change over time.

What did the PSMT SDT mean by “continuity” of the dc supply?

The PSMT SDT recognizes that there are several technological advances in equipment and testing procedures that allow the owner to choose how to verify that a battery string is free of open circuits. The term “continuity” was introduced into the standard to allow the owner to choose how to verify continuity (no open circuits) of a battery set by various methods, and not to limit the owner to other conventional methods of showing continuity--lack of an open circuit. Continuity, as used in Table 1-4 of the standard, refers to verifying that there is a continuous current path from the positive terminal of the station battery set to the negative terminal (no open circuit). Without verifying continuity of a station battery, there is no way to determine that the station battery is available to supply dc power to the station. Whether it is caused from an open cell or a bad external connection, an open battery string will be an unavailable power source in the event of loss of the battery charger.

The current path through a station battery from its positive to its negative connection to the dc control circuits is composed of two types of elements. These path elements are the electrochemical path through each of its cells and all of the internal and external metallic connections and terminations of the batteries in the battery set. If there is loss of continuity (an open circuit) in any part of the electrochemical or metallic path, the battery set will not be available for service. In the event of the loss of the ac source or battery charger, the battery must be capable of supplying dc current, both for continuous dc loads and for tripping breakers and switches. Without continuity, the battery cannot perform this function.

At generating stations and large transmission stations where battery chargers are capable of handling the maximum current required by the Protection System, there are still problems that could potentially occur when the continuity through the connected battery is interrupted.

- Many battery chargers produce harmonics which can cause failure of dc power supplies in microprocessor-based protective relays and other electronic devices connected to station dc supply. In these cases, the substation battery serves as a filter for these harmonics. With the loss of continuity in the battery, the filter provided by the battery is no longer present.
- Loss of electrical continuity of the station battery will cause, in most battery chargers, regardless of the battery charger’s output current capability, a delayed response in full output current from the charger. Almost all chargers have an intentional one- to two-second delay to switch from a low substation dc load current to the maximum output of the charger. This delay would cause the opening of circuit breakers to be delayed, which could violate system performance standards.

Monitoring of the station dc supply voltage will not indicate that there is a problem with the dc current path through the battery, unless the battery charger is taken out of service. At that time, a break in the continuity of the station battery current path will be revealed because there will

be no voltage on the station dc circuitry. This particular test method, while proving battery continuity, may not be acceptable to all installations.

Although the standard prescribes what must be accomplished during the maintenance activity, it does not prescribe how the maintenance activity should be accomplished. There are several methods that can be used to verify the electrical continuity of the battery. These are not the only possible methods, simply a sampling of some methods:

- One method is to measure that there is current flowing through the battery itself by a simple clamp on milliamp-range ammeter. A battery is always either charging or discharging. Even when a battery is charged, there is still a measurable float charge current that can be detected to verify that there is continuity in the electrical path through the battery.
- A simple test for continuity is to remove the battery charger from service and verify that the battery provides voltage and current to the dc system. However, the behavior of the various dc-supplied equipment in the station should be considered before using this approach.
- Manufacturers of microprocessor-controlled battery chargers have developed methods for their equipment to periodically (or continuously) test for battery continuity. For example, one manufacturer periodically reduces the float voltage on the battery until current from the battery to the dc load can be measured to confirm continuity.
- Applying test current (as in some ohmic testing devices, or devices for locating dc grounds) will provide a current that when measured elsewhere in the string, will prove that the circuit is continuous.
- Internal ohmic measurements of the cells and units of lead-acid batteries (valve-regulated lead-acid (VRLA) & vented lead-acid (VLA)~~VRLA & VLA~~) can detect lack of continuity within the cells of a battery string; and when used in conjunction with resistance measurements of the battery's external connections, can prove continuity. Also some methods of taking internal ohmic measurements, by their very nature, can prove the continuity of a battery string without having to use the results of resistance measurements of the external connections.
- Specific gravity tests could infer continuity because without continuity there could be no charging occurring; and if there is no charging, then specific gravity will go down below acceptable levels over time.

No matter how the electrical continuity of a battery set is verified, it is a necessary maintenance activity that must be performed at the intervals prescribed by Table 1-4 to insure that the station dc supply has a path that can provide the required current to the Protection System at all times.

When should I check the station batteries to see if they have sufficient energy to perform as manufactured?

The answer to this question depends on the type of battery (valve-regulated lead-acid, vented lead-acid, or nickel-cadmium) and the maintenance activity chosen.

For example, if you have a ~~valve-regulated lead-acid (VRLA)~~ station battery, and you have chosen to evaluate the measured cell/unit internal ohmic values to the battery cell's baseline,

you will have to perform verification at a maximum maintenance interval of no greater than every six months. While this interval might seem to be quite short, keep in mind that the six-month interval is important for VRLA batteries; this interval provides an accumulation of data that better shows when a VRLA battery is incapable of performing as manufactured.

If, for a VRLA station battery, you choose to conduct a performance capacity test on the entire station battery as the maintenance activity, then you will have to perform verification at a maximum maintenance interval of no greater than every three calendar years.

How is a baseline established for cell/unit internal ohmic measurements?

Establishment of cell/unit internal ohmic baseline measurements should be completed when lead-acid batteries are newly installed. To ensure that the baseline ohmic cell/unit values are most indicative of the station battery's ability to perform as manufactured, they should be made at some point in time after the installation to allow the cell chemistry to stabilize after the initial freshening charge. An accepted industry practice for establishing baseline values is after six-months of installation, with the battery fully charged and in service. However, it is recommended that each owner, when establishing a baseline, should consult the battery manufacturer for specific instructions on establishing an ohmic baseline for their product, if available.

When internal ohmic measurements are taken, the same make/model test equipment should be used to establish the baseline and used for the future trending of the cells internal ohmic measurements because of variances in test equipment and the type of ohmic measurement used by different manufacturer's equipment. Keep in mind that one manufacturer's "conductance" test equipment does not produce similar results as another manufacturer's "conductance" test equipment, even though both manufacturers have produced "ohmic" test equipment. Therefore, for meaningful results to an established baseline, the same make/model of instrument should be used.

For all new installations of ~~valve regulated lead acid (VRLA)~~ batteries and ~~vented lead acid (VLA)~~ batteries, where trending of the cells internal ohmic measurements to a baseline are to be used to determine the ability of the station battery to perform as manufactured, the establishment of the baseline, as described above, should be followed at the time of installation to insure the most accurate trending of the cell/unit. However, often for older VRLA batteries, the owners of the station batteries have not established a baseline at installation. Also for owners of VLA batteries who want to establish a maintenance activity which requires trending of measured ohmic values to a baseline, there was typically no baseline established at installation of the station battery to trend to.

To resolve the problem of the unavailability of baseline internal ohmic measurements for the individual cell/unit of a station battery, many manufacturers of internal ohmic measurement devices have established libraries of baseline values for VRLA and VLA batteries using their testing device. Also, several of the battery manufacturers have libraries of baselines for their products that can be used to trend to. However, it is important that when using battery manufacturer-supplied data that it is verified that the baseline readings to be used were taken with the same ohmic testing device that will be used for future measurements (for example "conductance readings" from one manufacturer's test equipment do not correlate to "impedance readings" from a different manufacturer's test equipment). Although many manufacturers may have provided baseline values, which will allow trending of the internal ohmic measurements over the remaining life of a station battery, these baselines are not the actual cell/unit measurements for

the battery being trended. It is important to have a baseline tailored to the station battery to more accurately use the tool of ohmic measurement trending. That more customized baseline can only be created by following the establishment of a baseline for each cell/unit at the time of installation of the station battery.

Why determine the State of Charge?

Even though there is no present requirement to check the state of charge of a battery, it can be a very useful tool in determining the overall condition of a battery system. The following discussions are offered as a general reference.

When a battery is fully charged, the battery is available to deliver its existing capacity. As a battery is discharged, its ability to deliver its maximum available capacity is diminished. It is necessary to determine if the state of charge has dropped to an unacceptable level.

What is State of Charge and how can it be determined in a station battery?

The state of charge of a battery refers to the ratio of residual capacity at a given instant to the maximum capacity available from the battery. When a battery is fully charged, the battery is available to deliver its existing capacity. As a battery is discharged, its ability to deliver its maximum available capacity is diminished. Knowing the amount of energy left in a battery compared with the energy it had when it was fully charged gives the user an indication of how much longer a battery will continue to perform before it needs recharging.

For ~~vented lead acid (VLA)~~ batteries which use accessible liquid electrolyte, a hydrometer can be used to test the specific gravity of each cell as a measure of its state of charge. The hydrometer depends on measuring changes in the weight of the active chemicals. As the battery discharges, the active electrolyte, sulfuric acid, is consumed and the concentration of the sulfuric acid in water is reduced. This, in turn, reduces the specific gravity of the solution in direct proportion to the state of charge. The actual specific gravity of the electrolyte can, therefore, be used as an indication of the state of charge of the battery. Hydrometer readings may not tell the whole story, as it takes a while for the acid to get mixed up in the cells of a VLA battery. If measured right after charging, you might see high specific gravity readings at the top of the cell, even though it is much less at the bottom. Conversely, if taken shortly after adding water to the cell, the specific gravity readings near the top of the cell will be lower than those at the bottom.

Nickel-cadmium batteries, where the specific gravity of the electrolyte does not change during battery charge and discharge, and ~~valve regulated lead acid (VRLA)~~ batteries, where the electrolyte is not accessible, cannot have their state of charge determined by specific gravity readings. For these two types of batteries, and for VLA batteries also, where another method besides taking hydrometer readings is desired, the state of charge may be determined by taking voltage and current readings at the battery terminals. The methods employed to obtain accurate readings vary for the different battery types. Manufacturers' information and IEEE guidelines can be consulted for specifics; (see IEEE 1106 Annex B for Nickel Cadmium batteries, IEEE 1188 Annex A for VRLA batteries and IEEE 450 for VLA batteries).

Why determine the Connection Resistance?

High connection resistance can cause abnormal voltage drop or excessive heating during discharge of a station battery. During periods of a high rate of discharge of the station battery, a very high resistance can cause severe damage. The maintenance requirement to verify battery

terminal connection resistance in Table 1-4 is established to verify that the integrity of all battery electrical connections is acceptable. This verification includes cell-to-cell (intercell) and external circuit terminations. Your method of checking for acceptable values of intercell and terminal connection resistance could be by individual readings, or a combination of the two. There are test methods presently that can read post termination resistances and resistance values between external posts. There are also test methods presently available that take a combination reading of the post termination connection resistance plus the intercell resistance value plus the post termination connection resistance value. Either of the two methods, or any other method, that can show if the adequacy of connections at the battery posts is acceptable.

Adequacy of the electrical terminations can be determined by comparing resistance measurements for all connections taken at the time of station battery's installation to the same resistance measurements taken at the maintenance interval chosen, not to exceed the maximum maintenance interval of Table 1-4. Trending of the interval measurements to the baseline measurements will identify any degradation in the battery connections. When the connection resistance values exceed the acceptance criteria for the connection, the connection is typically disassembled, cleaned, reassembled and measurements taken to verify that the measurements are adequate when compared to the baseline readings.

What conditions should be inspected for visible battery cells?

The maintenance requirement to inspect the cell condition of all station battery cells where the cells are visible is a maintenance requirement of Table 1-4. Station batteries are different from any other component in the Protection Station because they are a perishable product due to the electrochemical process which is used to produce dc electrical current and voltage. This inspection is a detailed visual inspection of the cells for abnormalities that occur in the aging process of the cell. In VLA battery visual inspections, some of the things that the inspector is typically looking for on the plates are signs of sulfation of the plates, abnormal colors (which are an indicator of sulfation or possible copper contamination) and abnormal conditions such as cracked grids. The visual inspection could look for symptoms of hydration that would indicate that the battery has been left in a completely discharged state for a prolonged period. Besides looking at the plates for signs of aging, all internal connections, such as the bus bar connection to each plate, and the connections to all posts of the battery need to be visually inspected for abnormalities. In a complete visual inspection for the condition of the cell the cell plates, separators and sediment space of each cell must be looked at for signs of deterioration. An inspection of the station battery's cell condition also includes looking at all terminal posts and cell-to-cell electric connections to ensure they are corrosion free. The case of the battery containing the cell, or cells, must be inspected for cracks and electrolyte leaks through cracks and the post seals.

This maintenance activity cannot be extended beyond the maximum maintenance interval of Table 1-4 by a Performance-Based Maintenance Program (PBM) because of the electrochemical aging process of the station battery, nor can there be any monitoring associated with it because there must be a visual inspection involved in the activity. A remote visual inspection could possibly be done, but its interval must be no greater than the maximum maintenance interval of Table 1-4.

Why is it necessary to verify the battery string can perform as manufactured? I only care that the battery can trip the breaker, which means that the battery can perform

as designed. I oversize my batteries so that even if the battery cannot perform as manufactured, it can still trip my breakers.

The fundamental answer to this question revolves around the concept of battery performance “as designed” vs. battery performance “as manufactured.” The purpose of the various sections of Table 1-4 of this standard is to establish requirements for the Protection System owner to maintain the batteries, to ensure they will operate the equipment when there is an incident that requires dc power, and ensure the batteries will continue to provide adequate service until at least the next maintenance interval. To meet these goals, the correct battery has to be properly selected to meet the design parameters, and the battery has to deliver the power it was manufactured to provide.

When testing batteries, it may be difficult to determine the original design (i.e., load profile) of the dc system. This standard is not intended as a design document, and requirements relating to design are, therefore, not included.

Where the dc load profile is known, the best way to determine if the system will operate as designed is to conduct a service test on the battery. However, a service test alone might not fully determine if the battery is healthy. A battery with 50% capacity may be able to pass a service test, but the battery would be in a serious state of deterioration and could fail at some point in the near future.

To ensure that the battery will meet the required load profile and continue to meet the load profile until the next maintenance interval, the installed battery must be sized correctly (i.e., a correct design), and it must be in a good state of health. Since the design of the dc system is not within the scope of the standard, the only consistent and reliable method to ensure that the battery is in a good state of health is to confirm that it can perform as manufactured. If the battery can perform as manufactured and it has been designed properly, the system should operate properly until the next maintenance interval.

How do I verify the battery string can perform as manufactured?

Optimally, actual battery performance should be verified against the manufacturer’s rating curves. The best practice for evaluating battery performance is via a performance test. However, due to both logistical and system reliability concerns, some Protection System owners prefer other methods to determine if a battery can perform as manufactured. There are several battery parameters that can be evaluated to determine if a battery can perform as manufactured. Ohmic measurements and float current are two examples of parameters that have been reported to assist in determining if a battery string can perform as manufactured.

The evaluation of battery parameters in determining battery health is a complex issue, and is not an exact science. This standard gives the user an opportunity to utilize other measured parameters to determine if the battery can perform as manufactured. It is the responsibility of the Protection System owner, however, to maintain a documented process that demonstrates the chosen parameter(s) and associated methodology used to determine if the battery string can perform as manufactured.

Whatever parameters are used to evaluate the battery (ohmic measurements, float current, float voltages, temperature, specific gravity, performance test, or combination thereof), the goal is to determine the value of the measurement (or the percentage change) at which the battery fails

to perform as manufactured, or the point where the battery is deteriorating so rapidly that it will not perform as manufactured before the next maintenance interval.

This necessitates the need for establishing and documenting a baseline. A baseline may be required of every individual cell, a particular battery installation, or a specific make, model, or size of a cell. Given a consistent cell manufacturing process, it may be possible to establish a baseline number for the cell (make/model/type) and, therefore, a subsequent baseline for every installation would not be necessary. However, future installations of the same battery types should be spot-checked to ensure that your baseline remains applicable.

Consistent testing methods by trained personnel are essential. Moreover, it is essential that these technicians utilize the same make/model of ohmic test equipment each time readings are taken in order to establish a meaningful and accurate trend line against the established baseline. The type of probe and its location (post, connector, etc.) for the reading need to be the same for each subsequent test. The room temperature should be recorded with the readings for each test as well. Care should be taken to consider any factors that might lead a trending program to become invalid.

Float current along with other measureable parameters can be used in lieu of or in concert with ohmic measurement testing to measure the ability of a battery to perform as manufactured. The key to using any of these measurement parameters is to establish a baseline and the point where the reading indicates that the battery will not perform as manufactured.

The establishment of a baseline may be different for various types of cells and for different types of installations. In some cases, it may be possible to obtain a baseline number from the battery manufacturer, although it is much more likely that the baseline will have to be established after the installation is complete. To some degree, the battery may still be “forming” after installation; consequently, determining a stable baseline may not be possible until several months after the battery has been in service.

The most important part of this process is to determine the point where the ohmic reading (or other measured parameter(s)) indicates that the battery cannot perform as manufactured. That point could be an absolute number, an absolute change, or a percentage change of an established baseline.

Since there are no universally-accepted repositories of this information, the Protection System owner will have to determine the value/percentage where the battery cannot perform as manufactured (heretofore referred to as a failed cell). This is the most difficult and important part of the entire process.

To determine the point where the battery fails to perform as manufactured, it is helpful to have a history of a battery type, if the data includes the parameter(s) used to evaluate the battery's ability to perform as manufactured against the actual demonstrated performance/capacity of a battery/cell.

For example, when an ohmic reading has been recorded that the user suspects is indicating a failed cell, a performance test of that cell (or string) should be conducted in order to prove/quantify that the cell has failed. Through this process, the user needs to determine the ohmic value at which the performance of the cell has dropped below 80% of the manufactured, rated performance. It is likely that there may be a variation in ohmic readings that indicates a failed cell (possibly significant). It is prudent to use the most conservative values to determine

the point at which the cell should be marked for replacement. Periodically, the user should demonstrate that an “adequate” ohmic reading equates to an adequate battery performance (>80% of capacity).

Similarly, acceptance criteria for "good" and "failed" cells should be established for other parameters such as float current, specific gravity, etc., if used to determine the ability of a battery to function as designed.

What happens if I change the make/model of ohmic test equipment after the battery has been installed for a period of time?

If a user decides to switch testers, either voluntarily or because the equipment is not supported/sold any longer, the user may have to establish a new base line and new parameters that indicate when the battery no longer performs as manufactured. The user always has a choice to perform a capacity test in lieu of establishing new parameters.

What are some of the differences between lead-acid and nickel-cadmium batteries?

There is a marked difference in the aging process of lead acid and nickel-cadmium station batteries. The difference in the aging process of these two types of batteries is chiefly due to the electrochemical process of the battery type. Aging and eventual failure of lead acid batteries is due to expansion and corrosion of the positive grid structure, loss of positive plate active material, and loss of capacity caused by physical changes in the active material of the positive plates. In contrast, the primary failure of nickel-cadmium batteries is due to the gradual linear aging of the active materials in the plates. The electrolyte of a nickel-cadmium battery only facilitates the chemical reaction (it functions only to transfer ions between the positive and negative plates), but is not chemically altered during the process like the electrolyte of a lead acid battery. A lead acid battery experiences continued corrosion of the positive plate and grid structure throughout its operational life while a nickel-cadmium battery does not.

Changes to the properties of a lead acid battery when periodically measured and trended to a baseline, can indicate aging of the grid structure, positive plate deterioration, or changes in the active materials in the plate.

Because of the clear differences in the aging process of lead acid and nickel-cadmium batteries, there are no significantly measurable properties of the nickel-cadmium battery that can be measured at a periodic interval and trended to determine aging. For this reason, Table 1-4(c) (Protection System Station dc supply Using nickel-cadmium [NiCad] Batteries) only specifies one minimum maintenance activity and associated maximum maintenance interval necessary to verify that the station battery can perform as manufactured by evaluating cell/unit measurements indicative of battery performance against the station battery baseline. This maintenance activity is to conduct a performance or modified performance capacity test of the entire battery bank.

Why in Table 1-4 of PRC-005-6 is there a maintenance activity to inspect the structural integrity of the battery rack?

The purpose of this inspection is to verify that the battery rack is correctly installed and has no deterioration that could weaken its structural integrity.

Because the battery rack is specifically manufactured for the battery that is mounted on it, weakening of its structural members by rust or corrosion can physically jeopardize the battery.

What is required to comply with the “Unintentional dc Grounds” requirement?

In most cases, the first ground that appears on a battery is not a problem. It is the unintentional ground that appears on the opposite pole that becomes problematic. Even then many systems are designed to operate favorably under some unintentional dc ground situations. It is up to the owner of the Protection System to determine if corrective actions are needed on detected unintentional dc grounds. The standard merely requires that a check be made for the existence of unintentional dc grounds. Obviously, a “check-off” of some sort will have to be devised by the inspecting entity to document that a check is routinely done for unintentional dc grounds because of the possible consequences to the Protection System.

Where the standard refers to “all cells,” is it sufficient to have a documentation method that refers to “all cells,” or do we need to have separate documentation for every cell? For example, do I need 60 individual documented check-offs for good electrolyte level, or would a single check-off per bank be sufficient?

A single check-off per battery bank is sufficient for documentation, as long as the single check-off attests to checking all cells/units.

Does this standard refer to Station batteries or all batteries; for example, Communications Site Batteries?

This standard refers to Station Batteries. The drafting team does not believe that the scope of this standard refers to communications sites. The batteries covered under PRC-005-6 are the batteries that supply the trip current to the trip coils of the interrupting devices that are a part of the Protection System. The SDT believes that a loss of power to the communications systems at a remote site would cause the communications systems associated with protective relays to alarm at the substation. At this point, the corrective actions can be initiated.

What are cell/unit internal ohmic measurements?

With the introduction of ~~Valve-Regulated Lead-Acid (VRLA)~~ batteries to station dc supplies in the 1980’s several of the standard maintenance tools that are used on ~~Vented Lead-Acid (VLA)~~ batteries were unable to be used on this new type of lead-acid battery to determine its state of health. The only tools that were available to give indication of the health of these new VRLA batteries were voltage readings of the total battery voltage, the voltage of the individual cells and periodic discharge tests.

In the search for a tool for determining the health of a VRLA battery several manufacturers studied the electrical model of a lead acid battery’s current path through its cell. The overall battery current path consists of resistance and inductive and capacitive reactance. The inductive reactance in the current path through the battery is so minuscule when compared to the huge capacitive reactance of the cells that it is often ignored in most circuit models of the battery cell. Taking the basic model of a battery cell manufacturers of battery test equipment have developed and marketed testing devices to take measurements of the current path to detect degradation in the internal path through the cell.

In the battery industry, these various types of measurements are referred to as ohmic measurements. Terms used by the industry to describe ohmic measurements are ac conductance, ac impedance, and dc resistance. They are defined by the test equipment providers and IEEE and refer to the method of taking ohmic measurements of a lead acid battery. For example, in one manufacturer’s ac conductance equipment measurements are taken by applying a voltage of a known frequency and amplitude across a cell or battery unit and observing the ac

current flow it produces in response to the voltage. A manufacturer of an ac impedance meter measures ac current of a known frequency and amplitude that is passed through the whole battery string and determines the impedances of each cell or unit by measuring the resultant ac voltage drop across them. On the other hand, dc resistance of a cell is measured by a third manufacturer's equipment by applying a dc load across the cell or unit and measuring the step change in both the voltage and current to calculate the internal dc resistance of the cell or unit.

It is important to note that because of the rapid development of the market for ohmic measurement devices, there were no standards developed or used to mandate the test signals used in making ohmic measurements. Manufacturers using proprietary methods and applying different frequencies and magnitudes for their signals have developed a diversity of measurement devices. This diversity in test signals coupled with the three different types of ohmic measurements techniques (impedance conductance and resistance) make it impossible to always get the same ohmic measurement for a cell with different ohmic measurement devices. However, IEEE has recognized the great value for choosing one device for ohmic measurement, no matter who makes it or the method to calculate the ohmic measurement. The only caution given by IEEE and the battery manufacturers is that when trending the cells of a lead acid station battery consistent ohmic measurement devices should be used to establish the baseline measurement and to trend the battery set for its entire life.

For VRLA batteries both IEEE Standard 1188 (Maintenance, Testing and Replacement of VRLA Batteries) and IEEE Standard 1187 (Installation Design and Installation of VRLA Batteries) recognize the importance of the maintenance activity of establishing a baseline for "cell/unit internal ohmic measurements (impedance, conductance and resistance)" and trending them at frequent intervals over the life of the battery. There are extensive discussions about the need for taking these measurements in these standards. IEEE Standard 1188 requires taking internal ohmic values as described in Annex C4 during regular inspections of the station battery. For VRLA batteries IEEE Standard 1188 in talking about the necessity of establishing a baseline and trending it over time says, "...depending on the degree of change a performance test, cell replacement or other corrective action may be necessary..." (IEEE std 1188-2005, C.4 page 18).

For VLA batteries IEEE Standard 484 (Installation of VLA batteries) gives several guidelines about establishing baseline measurements on newly installed lead acid stationary batteries. The standard also discusses the need to look for significant changes in the ohmic measurements, the caution that measurement data will differ with each type of model of instrument used, and lists a number of factors that affect ohmic measurements.

At the beginning of the 21st century, EPRI conducted a series of extensive studies to determine the relationship of internal ohmic measurements to the capacity of a lead acid battery cell. The studies indicated that internal ohmic measurements were in fact a good indicator of a lead acid battery cell's capacity, but because users often were only interested in the total station battery capacity and the technology does not precisely predict overall battery capacity, if a user only needs "an accurate measure of the overall battery capacity," they should "perform a battery capacity test."

Prior to the EPRI studies some large and small companies which owned and maintained station dc supplies in NERC Protection Systems developed maintenance programs where trending of ohmic measurements of cells/units of the station's battery became the maintenance activity for

determining if the station battery could perform as manufactured. By evaluation of the trending of the ohmic measurements over time, the owner could track the performance of the individual components of the station battery and determine if a total station battery or components of it required capacity testing, removal, replacement or in many instances replacement of the entire station battery. By taking this condition based approach these owners have eliminated having to perform capacity testing at prescribed intervals to determine if a battery needs to be replaced and are still able to effectively determine if a station battery can perform as manufactured.

My VRLA batteries have multiple-cells within an individual battery jar (or unit); how am I expected to comply with the cell-to-cell ohmic measurement requirements on these units that I cannot get to?

Measurement of cell/unit (not all batteries allow access to “individual cells” some “units” or jars may have multiple cells within a jar) internal ohmic values of all types of lead acid batteries where the cells of the battery are not visible is a station dc supply maintenance activity in Table 1-4. In cases where individual cells in a multi-cell unit are inaccessible, an ohmic measurement of the entire unit may be made.

I have a concern about my batteries being used to support additional auxiliary loads beyond my protection control systems in a generation station. Is ohmic measurement testing sufficient for my needs?

While this standard is focused on addressing requirements for Protection Systems, if batteries are used to service other load requirements beyond that of Protection Systems (e.g. pumps, valves, inverter loads), the functional entity may consider additional testing to confirm that the capacity of the battery is sufficient to support all loads.

Why verify voltage?

There are two required maintenance activities associated with verification of dc voltages in Table 1-4. These two required activities are to verify station dc supply voltage and float voltage of the battery charger, and have different maximum maintenance intervals. Both of these voltage verification requirements relate directly to the battery charger maintenance.

The verification of the dc supply voltage is simply an observation of battery voltage to prove that the charger has not been lost or is not malfunctioning; a reading taken from the battery charger panel meter or even SCADA values of the dc voltage could be some of the ways that one could satisfy the requirements. Low battery voltage below float voltage indicates that the battery may be on discharge and, if not corrected, the station battery could discharge down to some extremely low value that will not operate the Protection System. High voltage, close to or above the maximum allowable dc voltage for equipment connected to the station dc supply indicates the battery charger may be malfunctioning by producing high dc voltage levels on the Protection System. If corrective actions are not taken to bring the high voltage down, the dc power supplies and other electronic devices connected to the station dc supply may be damaged. The maintenance activity of verifying the float voltage of the battery charger is not to prove that a charger is lost or producing high voltages on the station dc supply, but rather to prove that the charger is properly floating the battery within the proper voltage limits. As above, there are many ways that this requirement can be met.

Why check for the electrolyte level?

In ~~vented lead acid (VLA)~~ and nickel-cadmium (NiCad) batteries the visible electrolyte level must be checked as one of the required maintenance activities that must be performed at an interval that is equal to or less than the maximum maintenance interval of Table 1-4. Because the electrolyte level in ~~valve-regulated lead acid (VRLA)~~ batteries cannot be observed, there is no maintenance activity listed in Table 1-4 of the standard for checking the electrolyte level. Low electrolyte level of any cell of a VLA or NiCad station battery is a condition requiring correction. Typically, the electrolyte level should be returned to an acceptable level for both types of batteries (VLA and NiCad) by adding distilled or other approved-quality water to the cell.

Often people confuse the interval for watering all cells required due to evaporation of the electrolyte in the station battery cells with the maximum maintenance interval required to check the electrolyte level. In many of the modern station batteries, the jar containing the electrolyte is so large with the band between the high and low electrolyte level so wide that normal evaporation which would require periodic watering of all cells takes several years to occur. However, because loss of electrolyte due to cracks in the jar, overcharging of the station battery, or other unforeseen events can cause rapid loss of electrolyte; the shorter maximum maintenance intervals for checking the electrolyte level are required. A low level of electrolyte in a VLA battery cell which exposes the tops of the plates can cause the exposed portion of the plates to accelerated sulfation resulting in loss of cell capacity. Also, in a VLA battery where the electrolyte level goes below the end of the cell withdrawal tube or filling funnel, gasses can exit the cell by the tube instead of the flame arrester and present an explosion hazard.

What are the parameters that can be evaluated in Tables 1-4(a) and 1-4(b)?

The most common parameter that is periodically trended and evaluated by industry today to verify that the station battery can perform as manufactured is internal ohmic cell/unit measurements.

In the mid-1990s, several large and small utilities began developing maintenance and testing programs for Protection System station batteries using a condition based maintenance approach of trending internal ohmic measurements to each station battery cell's baseline value. Battery owners use the data collected from this maintenance activity to determine (1) when a station battery requires a capacity test (instead of performing a capacity test on a predetermined, prescribed interval), (2) when an individual cell or battery unit should be replaced, or (3) based on the analysis of the trended data, if the station battery should be replaced without performing a capacity test.

Other examples of measurable parameters that can be periodically trended and evaluated for lead acid batteries are cell voltage, float current, connection resistance. However, periodically trending and evaluating cell/unit Ohmic measurements are the most common battery/cell parameters that are evaluated by industry to verify a lead acid battery string can perform as manufactured.

Why does it appear that there are two maintenance activities in Table 1-4(b) (for VRLA batteries) that appear to be the same activity and have the same maximum maintenance interval?

There are two different and distinct reasons for doing almost the same maintenance activity at the same interval for ~~valve-regulated lead acid (VRLA)~~ batteries. The first similar activity for VRLA batteries (Table 1-4(b)) that has the same maximum maintenance interval is to “measure battery cell/unit internal ohmic values.” Part of the reason for this activity is because the visual inspection of the cell condition is unavailable for VRLA batteries. Besides the requirement to measure the internal ohmic measurements of VRLA batteries to determine the internal health of the cell, the maximum maintenance interval for this activity is significantly shorter than the interval for ~~vented lead acid (VLA)~~ due to some unique failure modes for VRLA batteries. Some of the potential problems that VRLA batteries are susceptible to that do not affect VLA batteries are thermal runaway, cell dry-out, and cell reversal when one cell has a very low capacity.

The other similar activity listed in Table 1-4(b) is “...verify that the station battery can perform as manufactured by evaluating the measured cell/unit measurements indicative of battery performance (e.g. internal ohmic values) against the station battery baseline.” This activity allows an owner the option to choose between this activity with its much shorter maximum maintenance interval or the longer maximum maintenance interval for the maintenance activity to “Verify that the station battery can perform as manufactured by conducting a performance or modified performance capacity test of the entire battery bank.”

For VRLA batteries, there are two drivers for internal ohmic readings. The first driver is for a means to trend battery life. Trending against the baseline of VRLA cells in a battery string is essential to determine the approximate state of health of the battery. Ohmic measurement testing may be used as the mechanism for measuring the battery cells. If all the cells in the string exhibit a consistent trend line and that trend line has not risen above a specific deviation (e.g. 30%) over baseline for impedance tests or below baseline for conductance tests, then a judgment can be made that the battery is still in a reasonably good state of health and able to ‘perform as manufactured.’ It is essential that the specific deviation mentioned above is based on data (test or otherwise) that correlates the ohmic readings for a specific battery/tester combination to the health of the battery. This is the intent of the “perform as manufactured six-month test” at Row 4 on Table 1-4b.

The second big driver is VRLA batteries tendency for thermal runaway. This is the intent of the “thermal runaway test” at Row 2 on Table 1-4b. In order to detect a cell in thermal runaway, you need not necessarily have a formal trending program. When a single cell/unit changes significantly or significantly varies from the other cells (e.g. a doubling of resistance/impedance or a 50% decrease in conductance), there is a high probability that the cell/unit/string needs to be replaced as soon as possible. In other words, if the battery is 10 years old and all the cells have approached a significant change in ohmic values over baseline, then you have a battery which is approaching end of life. You need to get ready to buy a new battery, but you do not have to worry about an impending catastrophic failure. On the other hand, if the battery is five years old and you have one cell that has a markedly different ohmic reading than all the other cells, then you need to be worried that this cell is susceptible to thermal runaway. If the float (charging) current has risen significantly and the ohmic measurement has increased/decreased as described above then concern of catastrophic failure should trigger attention for corrective action.

If an entity elects to use a capacity test rather than a cell ohmic value trending program, this does not eliminate the need to be concerned about thermal runaway--the entity still needs to do the six-month readings and look for cells which are outliers in the string but they need not trend

results against the factory/as new baseline. Some entities will not mind the extra administrative burden of having the ongoing trending program against baseline--others would rather just do the capacity test and not have to trend the data against baseline. Nonetheless, all entities must look for ohmic outliers on a six-month basis.

It is possible to accomplish both tasks listed (trend testing for capability and testing for thermal runaway candidates) with the very same ohmic test. It becomes an analysis exercise of watching the trend from baselines and watching for the oblique cell measurement.

In table 1-4(f) (Exclusions for Protection System Station dc Supply Monitoring Devices and Systems), must all component attributes listed in the table be met before an exclusion can be granted for a maintenance activity?

Table 1-4(f) was created by the drafting team to allow Protection System dc supply owners to obtain exclusions from periodic maintenance activities by using monitoring devices. The basis of the exclusions granted in the table is that the monitoring devices must incorporate the monitoring capability of microprocessor based components which perform continuous self-monitoring. For failure of the microprocessor device used in dc supply monitoring, the self-checking routine in the microprocessor must generate an alarm which will be reported within 24 hours of device failure to a location where corrective action can be initiated.

Table 1-4(f) lists 8 component attributes along with a specific periodic maintenance activity associated with each of the 8 attributes listed. If an owner of a station dc supply wants to be excluded from periodically performing one of the 8 maintenance activities listed in table 1-4(f), the owner must have evidence that the monitoring and alarming component attributes associated with the excluded maintenance activity are met by the self-checking microprocessor based device with the specific component attribute listed in the table 1-4(f).

For example if an owner of a VLA station battery does not want to “verify station dc supply voltage” every “4 calendar months” (see table 1-4(a)), the owner can install a monitoring and alarming device “with high and low voltage monitoring and alarming of the battery charger voltage to detect charger overvoltage and charger failure” and “no periodic verification of station dc supply voltage is required” (see table 1-4(f) first row). However, if for the same Protection System discussed above, the owner does not install “electrolyte level monitoring and alarming in every cell” and “unintentional dc ground monitoring and alarming” (see second and third rows of table 1-4(f)), the owner will have to “inspect electrolyte level and for unintentional grounds” every “4 calendar months” (see table 1-4(a)).

15.5 Associated communications equipment (Table 1-2)

The equipment used for tripping in a communications-assisted trip scheme is a vital piece of the trip circuit. Remote action causing a local trip can be thought of as another parallel trip path to the trip coil that must be tested. Besides the trip output and wiring to the trip coil(s), there is also a communications medium that must be maintained. Newer technologies now exist that achieve communications-assisted tripping without the conventional wiring practices of older

technology. For example, older technologies may have included Frequency Shift Key methods. This technology requires that guard and trip levels be maintained. The actual tripping path(s) to the trip coil(s) may be tested as a parallel trip path within the dc control circuitry tests. Emerging technologies transfer digital information over a variety of carrier mediums that are then interpreted locally as trip signals. The requirements apply to the communicated signal needed for the proper operation of the protective relay trip logic or scheme. Therefore, this standard is applied to equipment used to convey both trip signals (permissive or direct) and block signals.

It was the intent of this standard to require that a test be performed on any communications-assisted trip scheme, regardless of the vintage of technology. The essential element is that the tripping (or blocking) occurs locally when the remote action has been asserted; or that the tripping (or blocking) occurs remotely when the local action is asserted. Note that the required testing can still be done within the concept of testing by overlapping segments. Associated communications equipment can be (but is not limited to) testing at other times and different frequencies as the protective relays, the individual trip paths and the affected circuit interrupting devices.

Some newer installations utilize digital signals over fiber-optics from the protective relays in the control house to the circuit interrupting device in the yard. This method of tripping the circuit breaker, even though it might be considered communications, must be maintained per the dc control circuitry maintenance requirements.

15.5.1 Frequently Asked Questions:

What are some examples of mechanisms to check communications equipment functioning?

For unmonitored Protection Systems, various types of communications systems will have different facilities for on-site integrity checking to be performed at least every four months during a substation visit. Some examples are, but not limited to:

- On-off power-line carrier systems can be checked by performing a manual carrier keying test between the line terminals, or carrier check-back test from one terminal.
- Systems which use frequency-shift communications with a continuous guard signal (over a telephone circuit, analog microwave system, etc.) can be checked by observing for a loss-of-guard indication or alarm. For frequency-shift power-line carrier systems, the guard signal level meter can also be checked.
- Hard-wired pilot wire line Protection Systems typically have pilot-wire monitoring relays that give an alarm indication for a pilot wire ground or open pilot wire circuit loop.
- Digital communications systems typically have a data reception indicator or data error indicator (based on loss of signal, bit error rate, or frame error checking).

For monitored Protection Systems, various types of communications systems will have different facilities for monitoring the presence of the communications channel, and activating alarms that can be monitored remotely. Some examples are, but not limited to:

- On-off power-line carrier systems can be shown to be operational by automated periodic power-line carrier check-back tests with remote alarming of failures.

-
- Systems which use a frequency-shift communications with a continuous guard signal (over a telephone circuit, analog microwave system, etc.) can be remotely monitored with a loss-of-guard alarm or low signal level alarm.
 - Hard-wired pilot wire line Protection Systems can be monitored by remote alarming of pilot-wire monitoring relays.
 - Digital communications systems can activate remotely monitored alarms for data reception loss or data error indications.
 - Systems can be queried for the data error rates.

For the highest degree of monitoring of Protection Systems, the communications system must monitor all aspects of the performance and quality of the channel that show it meets the design performance criteria, including monitoring of the channel interface to protective relays.

- In many communications systems signal quality measurements, including signal-to-noise ratio, received signal level, reflected transmitter power or standing wave ratio, propagation delay, and data error rates are compared to alarm limits. These alarms are connected for remote monitoring.
- Alarms for inadequate performance are remotely monitored at all times, and the alarm communications system to the remote monitoring site must itself be continuously monitored to assure that the actual alarm status at the communications equipment location is continuously being reflected at the remote monitoring site.

What is needed for the four-month inspection of communications-assisted trip scheme equipment?

The four-month inspection applies to unmonitored equipment. An example of compliance with this requirement might be, but is not limited to:

With each site visit, check that the equipment is free from alarms; check any metered signal levels, and that power is still applied. While this might be explicit for a particular type of equipment (i.e., FSK equipment), the concept should be that the entity verify that the communications equipment that is used in a Protection System is operable through a cursory inspection and site visit. This site visit can be eliminated on this particular example if the FSK equipment had a monitored alarm on Loss of Guard. Blocking carrier systems with auto checkbacks will present an alarm when the channel fails allowing a visual indication. With no auto checkback, the channel integrity will need to be verified by a manual checkback or a two ended signal check. This check could also be eliminated by bring the auto checkback failure alarm to the monitored central location.

Does a fiber optic I/O scheme used for breaker tripping or control within a station, for example - transmitting a trip signal or control logic between the control house and the breaker control cabinet, constitute a communications system?

This equipment is presently classified as being part of the Protection System control circuitry and tested per the portions of Table 1 applicable to “Protection System Control Circuitry”, rather than those portions of the table applicable to communications equipment.

What is meant by “Channel” and “Communications Systems” in Table 1-2?

The transmission of logic or data from a relay in one station to a relay in another station for use in a pilot relay scheme will require a communications system of some sort. Typical relay communications systems use fiber optics, leased audio channels, power line carrier, and microwave. The overall communications system includes the channel and the associated communications equipment.

This standard refers to the “channel” as the medium between the transmitters and receivers in the relay panels such as a leased audio or digital communications circuit, power line and power line carrier auxiliary equipment, and fiber. The dividing line between the channel and the associated communications equipment is different for each type of media.

Examples of the Channel:

- Power Line Carrier (PLC) - The PLC channel starts and ends at the PLC transmitter and receiver output unless there is an internal hybrid. The channel includes the external hybrids, tuners, wave traps and the power line itself.
- Microwave –The channel includes the microwave multiplexers, radios, antennae and associated auxiliary equipment. The audio tone and digital transmitters and receivers in the relay panel are the associated communications equipment.
- Digital/Audio Circuit – The channel includes the equipment within and between the substations. The associated communications equipment includes the relay panel transmitters and receivers and the interface equipment in the relays.
- Fiber Optic – The channel starts at the fiber optic connectors on the fiber distribution panel at the local station and goes to the fiber optic distribution panel at the remote substation. The jumpers that connect the relaying equipment to the fiber distribution panel and any optical-electrical signal format converters are the associated communications equipment.

Figure 1-2, A-1 and A-2 at the end of this document show good examples of the communications channel and the associated communications equipment.

In Table 1-2, the Maintenance Activities section of the Protection System Communications Equipment and Channels refers to the quality of the channel meeting “performance criteria.” What is meant by performance criteria?

Protection System communications channels must have a means of determining if the channel and communications equipment is operating normally. If the channel is not operating normally, an alarm will be indicated. For unmonitored systems, this alarm will probably be on the panel. For monitored systems, the alarm will be transmitted to a remote location.

Each entity will have established a nominal performance level for each Protection System communications channel that is consistent with proper functioning of the Protection System. If that level of nominal performance is not being met, the system will go into alarm. Following are some examples of Protection System communications channel performance measuring:

- For direct transfer trip using a frequency shift power line carrier channel, a guard level monitor is part of the equipment. A normal receive level is established when the system is calibrated and if the signal level drops below an established level, the system will indicate an alarm.

-
- An on-off blocking signal over power line carrier is used for directional comparison blocking schemes on transmission lines. During a Fault, block logic is sent to the remote relays by turning on a local transmitter and sending the signal over the power line to a receiver at the remote end. This signal is normally off so continuous levels cannot be checked. These schemes use check-back testing to determine channel performance. A predetermined signal sequence is sent to the remote end and the remote end decodes this signal and sends a signal sequence back. If the sending end receives the correct information from the remote terminal, the test passes and no alarm is indicated. Full power and reduced power tests are typically run. Power levels for these tests are determined at the time of calibration.
 - Pilot wire relay systems use a hardwire communications circuit to communicate between the local and remote ends of the protective zone. This circuit is monitored by circulating a dc current between the relay systems. A typical level may be 1 mA. If the level drops below the setting of the alarm monitor, the system will indicate an alarm.
 - Modern digital relay systems use data communications to transmit relay information to the remote end relays. An example of this is a line current differential scheme commonly used on transmission lines. The protective relays communicate current magnitude and phase information over the communications path to determine if the Fault is located in the protective zone. Quantities such as digital packet loss, bit error rate and channel delay are monitored to determine the quality of the channel. These limits are determined and set during relay commissioning. Once set, any channel quality problems that fall outside the set levels will indicate an alarm.

The previous examples show how some protective relay communications channels can be monitored and how the channel performance can be compared to performance criteria established by the entity. This standard does not state what the performance criteria will be; it just requires that the entity establish nominal criteria so Protection System channel monitoring can be performed.

How is the performance criteria of Protection System communications equipment involved in the maintenance program?

An entity determines the acceptable performance criteria, depending on the technology implemented. If the communications channel performance of a Protection System varies from the pre-determined performance criteria for that system, then these results should be investigated and resolved.

How do I verify the A/D converters of microprocessor-based relays?

There are a variety of ways to do this. Two examples would be: using values gathered via data communications and automatically comparing these values with values from other sources, or using groupings of other measurements (such as vector summation of bus feeder currents) for comparison. Many other methods are possible.

15.6 Alarms (Table 2)

In addition to the tables of maintenance for the components of a Protection System, there is an additional table added for alarms. This additional table was added for clarity. This enabled the common alarm attributes to be consolidated into a single spot, and, thus, make it easier to read

the Tables 1-1 through 1-5, Table 3, and Table 4. The alarms need to arrive at a site wherein a corrective action can be initiated. This could be a control room, operations center, etc. The alarming mechanism can be a standard alarming system or an auto-polling system; the only requirement is that the alarm be brought to the action-site within 24 hours. This effectively makes manned-stations equivalent to monitored stations. The alarm of a monitored point (for example a monitored trip path with a lamp) in a manned-station now makes that monitored point eligible for monitored status. Obviously, these same rules apply to a non-manned-station, which is that if the monitored point has an alarm that is auto-reported to the operations center (for example) within 24 hours, then it too is considered monitored.

15.6.1 Frequently Asked Questions:

Why are there activities defined for varying degrees of monitoring a Protection System component when that level of technology may not yet be available?

There may already be some equipment available that is capable of meeting the highest levels of monitoring criteria listed in the Tables. However, even if there is no equipment available today that can meet this level of monitoring the standard establishes the necessary requirements for when such equipment becomes available. By creating a roadmap for development, this provision makes the standard technology neutral. The Standard Drafting Team wants to avoid the need to revise the standard in a few years to accommodate technology advances that may be coming to the industry.

Does a fail-safe “form b” contact that is alarmed to a 24/7 operation center classify as an alarm path with monitoring?

If the fail-safe “form-b” contact that is alarmed to a 24/7 operation center causes the alarm to activate for failure of any portion of the alarming path from the alarm origin to the 24/7 operations center, then this can be classified as an alarm path with monitoring.

15.7 Distributed UFLS and Distributed UVLS Systems (Table 3)

Distributed UFLS and distributed UVLS systems have their maintenance activities documented in Table 3 due to their distributed nature allowing reduced maintenance activities and extended maximum maintenance intervals. Relays have the same maintenance activities and intervals as Table 1-1. Voltage and current-sensing devices have the same maintenance activity and interval as Table 1-3. DC systems need only have their voltage read at the relay every 12 years. Control circuits have the following maintenance activities every 12 years:

- Verify the trip path between the relay and lock-out and/or auxiliary tripping device(s).
- Verify operation of any lock-out and/or auxiliary tripping device(s) used in the trip circuit.
- No verification of trip path required between the lock-out (and/or auxiliary tripping device) and the non-BES interrupting device.
- No verification of trip path required between the relay and trip coil for circuits that have no lock-out and/or auxiliary tripping device(s).
- No verification of trip coil required.

No maintenance activity is required for associated communication systems for distributed UFLS and distributed UVLS schemes.

Non-BES interrupting devices that participate in a distributed UFLS or distributed UVLS scheme are excluded from the tripping requirement, and part of the control circuit test requirement; however, the part of the trip path control circuitry between the Load-Shed relay and lock-out or auxiliary tripping relay must be tested at least once every 12 years. In the case where there is no lock-out or auxiliary tripping relay used in a distributed UFLS or UVLS scheme which is not part of the BES, there is no control circuit test requirement. There are many circuit interrupting devices in the distribution system that will be operating for any given under-frequency event that requires tripping for that event. A failure in the tripping action of a single distributed system circuit breaker (or non-BES equipment interruption device) will be far less significant than, for example, any single transmission Protection System failure, such as a failure of a bus differential lock-out relay. While many failures of these distributed system circuit breakers (or non-BES equipment interruption device) could add up to be significant, it is also believed that many circuit breakers are operated often on just Fault clearing duty; and, therefore, these circuit breakers are operated at least as frequently as any requirements that appear in this standard.

There are times when a Protection System component will be used on a BES device, as well as a non-BES device, such as a battery bank that serves both a BES circuit breaker and a non-BES interrupting device used for UFLS. In such a case, the battery bank (or other Protection System component) will be subject to the Tables of the standard because it is used for the BES.

15.7.1 Frequently Asked Questions:

The standard reaches further into the distribution system than we would like for UFLS and UVLS

While UFLS and UVLS equipment are located on the distribution network, their job is to protect the Bulk Electric System. This is not beyond the scope of NERC's Section 215 authority.

FPA section 215(a) definitions section defines bulk power system as: "(A) facilities and control Systems necessary for operating an interconnected electric energy transmission network (or any portion thereof)." That definition, then, is limited by a later statement which adds the term bulk power system "...does not include facilities used in the local distribution of electric energy." Also, Section 215 also covers users, owners, and operators of bulk power Facilities.

UFLS and UVLS (when the UVLS is installed to prevent system voltage collapse or voltage instability for BES reliability) are not "used in the local distribution of electric energy," despite their location on local distribution networks. Further, if UFLS/UVLS Facilities were not covered by the reliability standards, then in order to protect the integrity of the BES during under-frequency or under-voltage events, that Load would have to be shed at the Transmission bus to ensure the Load-generation balance and voltage stability is maintained on the BES.

15.8 Automatic Reclosing (Table 4)

Please see the document referenced in Section F of PRC-005-3, "Considerations for Maintenance and Testing of Autoreclosing Schemes — November 2012", for a discussion of Automatic Reclosing as addressed in PRC-005-3.

15.8.1 Frequently-asked Questions

Automatic Reclosing is a control, not a protective function; why then is Automatic Reclosing maintenance included in the Protection System Maintenance Program (PSMP)?

Automatic Reclosing is a control function. The standard's title 'Protection System and Automatic Reclosing Maintenance' clearly distinguishes (separates) the Automatic Reclosing from the Protection System. Automatic Reclosing is included in the PSMP because it is a more pragmatic approach as compared to creating a parallel and essentially identical 'Control System Maintenance Program' for the Automatic Reclosing component types.

When do I need to have the initial maintenance of Automatic Reclosing Components completed upon change of the largest BES generating unit in the BA/RSG?

The maintenance interval, for newly identified Automatic Reclosing Components, starts when a change in the largest BES generating unit is determined by the BA/RSG. The first maintenance records for newly identified Automatic Reclosing Components should be dated no later than the maximum maintenance interval after the identification date. The maximum maintenance intervals for each newly identified Component are defined in Table 4. No activities or records are required prior to the date of identification.

Our maintenance practice consists of initiating the Automatic Reclosing relay and confirming the breaker closes properly and the close signal is released. This practice verifies the control circuitry associated with Automatic Reclosing. Do you agree?"

The described task partially verifies the control circuit maintenance activity. To meet the control circuit maintenance activity, responsible entities need to verify, *upon initiation*, that the reclosing relay does not issue a *premature closing command*. As noted on page 12 of the SAMS/SPCS report, the concern being addressed within the standard is premature auto reclosing that has the potential to cause generating unit or plant instability. Reclosing applications have many variations, responsible entities will need to verify the applicability of associated supervision/conditional logic and the reclosing relay operation; then verify the conditional logic or that the reclosing relay performs in a manner that does not result in a *premature closing command* being issued.

Some examples of conditions which can result in a premature closing command are: an improper supervision or conditional logic input which provides a false state and allows the reclosing relay to issue an improper close command based on incorrect conditions (i.e. voltage supervision, equipment status, sync window verification); timers utilized for closing actuation or reclosing arming/disarming circuitry which could allow the reclosing relay to issue an improper close command; a reclosing relay output contact failure which could result in a made-up-close condition / failure-to-release condition.

Why was a close-in three phase fault present for twice the normal clearing time chosen for the Automatic Reclosing exclusion? It exceeds TPL requirements and ignores the breaker closing time in a trip-close-trip sequence, thus making the exclusion harder to attain.

This condition represents a situation where a close signal is issued with no time delay or with less time delay than is intended, such as if a reclosing contact is welded closed. This failure mode can result in a minimum trip-close-trip sequence with the two faults cleared in primary protection operating time, and the open time between faults equal to the breaker closing cycle

time. The sequence for this failure mode results in system impact equivalent to a high-speed autoreclosing sequence with no delay added in the autoreclosing logic. It represents a failure mode which must be avoided because it exceeds TPL requirements.

Do we have to test the various breaker closing circuit interlocks and controls such as anti-pump?

These components are not specifically addressed within Table 4, and need not be individually tested.

For Automatic Reclosing that is not part of an RAS, do we have to close the circuit breaker periodically?

No--for this application, you need only to verify that the Automatic Reclosing, upon initiation, does not issue a premature closing command. This activity is concerned only with assuring that a premature close does not occur, and cause generating plant instability.

For Automatic Reclosing that is part of an RAS, do we have to close the circuit breaker periodically?

Yes--in this application, successful closing is a necessary portion of the RAS, and must be verified.

Why is maintenance of supervisory relays now included in PRC-005 for Automatic Reclosing?

Proper performance of supervising relays supports the reliability of the BES because some conditions can result in a premature closing command. An example of this would be an improper supervision or conditional logic input which provides a false state and allows the reclosing relay to issue an improper close command based on incorrect conditions (i.e. voltage supervision, sync window verification)

My reclosing circuitry contains the following inputs listed below. ~~Which parts of the control circuitry would need to be verified, upon initiation, do not issue a premature close command per PRC-005?~~

- 79/ON – Supervisory contact which turns Automatic Reclosing ON or OFF
- 52 – Supervisory contact which provides breaker indication (“b” contact)
- 86 - Supervisory contact from a lockout relay
- 79 – Supervisory contact from a reclosing relay
- 25 – Supervisory contact from a sync-check relay
- 27 or 59 – Supervisory contact from an undervoltage or overvoltage relay

Which parts of the control circuitry would need to be verified, upon initiation, do not issue a premature close command per PRC-005?

Supervisory Relays are defined in this standard as “relay(s) that perform voltage and/or sync check functions that enables or disables operation of the reclosing relay.” The 79, 25, and 27 or 59 would need to be verified because they are supervisory devices that are associated with Automatic Reclosing. The 79/ON, 52, and 86 would not need to be verified.

The sync check and voltage check functions are part of my microprocessor reclosing relay. Are there any test requirements for these internal supervisory functions?

A microprocessor reclosing relay that is using internal sync check or voltage check supervisory functions is a combinational reclosing and supervisory relay (i.e. 79/25).). The maintenance activities for both a reclosing relay and supervisory relay would apply. The voltage sensing devices providing input to a combinational reclosing and supervisory relay would require the activities in Table 4-3.

Is it necessary to verify the close signal operates the breaker?

Only when the control circuitry associated with automatic reclosing is a part of a RAS, then all paths that are essential for proper operation of the RAS must be verified, per table 4-2(b).

15.9 Sudden Pressure Relaying (Table 5)

Please see the document referenced in Section F of PRC-005-6, “Sudden Pressure Relays and Other Devices that Respond to Non-Electrical Quantities – December 2013”, for a discussion of Sudden Pressure Relaying as addressed in PRC-005-6.

15.9.1 Frequently Asked Questions:

How do I verify the pressure or flow sensing mechanism is operable?

Maintenance activities for the fault pressure relay associated with Sudden Pressure Relaying in PRC-005-6 are intended to verify that the pressure and/or flow sensing mechanism are functioning correctly. Beyond this, PRC-005-6 requires no calibration (adjusting the operating threshold or measurement accuracy of a measuring element to meet the intended performance requirement) or testing (applying signals to a component to observe functional performance or output behavior, or to diagnose problems) activities. For example, some designs of flow sensing mechanisms allow the operation of a test switch to actuate the limit switch of the flow sensing mechanism. Operation of this test switch and verification of the flow sensing mechanism would meet the requirements of the maintenance activity. Another example involves a gas pressure sensing mechanism which is isolated by a test plug. Removal of the plug and verification of the bellows mechanism would meet the requirements of the maintenance activity.

Why the 6-year maximum maintenance interval for fault pressure relays?

The SDT established the six-year maintenance interval for fault pressure relays (see Table 5, PRC-005-6) based on the recommendation of the System Protection and Control Subcommittee (SPCS). The technical experts of the SPCS were tasked with developing the technical documents to:

- i. Describe the devices and functions (to include sudden pressure relays which trip for fault conditions) that should address FERC’s concern; and
- ii. Propose minimum maintenance activities for such devices and maximum maintenance intervals, including the technical basis for each.

Excerpt from the [SPCS technical report](#): “In order to determine present industry practices related to sudden pressure relay maintenance, the SPCS conducted a survey of Transmission Owners and

Generator Owners in all eight Regions requesting information related to their maintenance practices.” The SPCS received responses from 75 Transmission Owners and 109 Generator Owners. Note that, for the purpose of the survey, sudden pressure relays included the following: the “sudden pressure relay” (SPR) originally manufactured by Westinghouse, the “rapid pressure rise relay” (RPR) manufactured by Qualitrol, and a variety of Buchholz relays.

Table 2 provides a summary of the results of the responses:

Table 2: Sudden Pressure Relay Maintenance Practices – Survey Results		
	Transmission Owner	Generator Owner
Number of responding owners that trip with Sudden Pressure Relays:	67	84
Percentage of responding owners who trip that have a Maintenance Program:	75%	78%
Percentage of maintenance programs that include testing the pressure actuator:	81%	77%
Average Maintenance interval reported:	5.9 years	4.9 years

Additionally, in order to validate the information noted above, the SPCS contacted the following entities for their feedback: the IEEE Power System Relaying Committee, the IEEE Transformer Committee, the Doble Transformer Committee, the NATF System Protection Practices Group, and the EPRI Generator Owner/Operator Technical Focus Group. All of these organizations indicated the results of the SPCS survey are consistent with their respective experiences.

The SPCS discussed the potential difference between the recommended intervals for fault pressure relaying and intervals for transformer maintenance. The SPCS developed the recommended intervals for fault pressure relaying by comparing fault pressure relaying to Protection System Components with similar physical attributes. The SPCS recognized that these intervals may be shorter than some existing or future transformer maintenance intervals, but believed it to be more important to base intervals for fault pressure relaying on similar Protection System Components than transformer maintenance intervals.

The maintenance interval for fault pressure relays can be extended by utilizing performance-based maintenance thereby allowing entities that have maintenance intervals for transformers in excess of six years, to align them.

Sudden Pressure Relaying control circuitry is now specifically mentioned in the maintenance tables. Do we have to trip our circuit breaker specifically from the trip output of the sudden pressure relay?

No--verification may be by breaker tripping, but may be verified in overlapping segments with the Protection System control circuitry.

Can we use Performance Based Maintenance for fault pressure relays?

Yes--performance Based Maintenance is applicable to fault pressure relays.

15.10 Examples of Evidence of Compliance

To comply with the requirements of this standard, an entity will have to document and save evidence. The evidence can be of many different forms. The Standard Drafting Team recognizes that there are concurrent evidence requirements of other NERC standards that could, at times, fulfill evidence requirements of this standard.

15.10.1 Frequently Asked Questions:

What forms of evidence are acceptable?

Acceptable forms of evidence, as relevant for the requirement being documented include, but are not limited to:

- Process documents or plans
- Data (such as relay settings sheets, photos, SCADA, and test records)
- Database lists, records and/or screen shots that demonstrate compliance information
- Prints, diagrams and/or schematics
- Maintenance records
- Logs (operator, substation, and other types of log)
- Inspection forms
- Mail, memos, or email proving the required information was exchanged, coordinated, submitted or received
- Check-off forms (paper or electronic)
- Any record that demonstrates that the maintenance activity was known, accounted for, and/or performed.

If I replace a failed Protection System component with another component, what testing do I need to perform on the new component?

In order to reset the Table 1 maintenance interval for the replacement component, all relevant Table 1 activities for the component should be performed.

I have evidence to show compliance for PRC-016 (“Special Protection System Misoperation”). Can I also use it to show compliance for this Standard, PRC-005-6?

Maintaining evidence for operation of Remedial Action Schemes could concurrently be utilized as proof of the operation of the associated trip coil (provided one can be certain of the trip coil involved). Thus, the reporting requirements that one may have to do for the Misoperation of a Special Protection Scheme under PRC-016 could work for the activity tracking requirements under this PRC-005-6.

I maintain Disturbance records which show Protection System operations. Can I use these records to show compliance?

These records can be concurrently utilized as dc trip path verifications, to the degree that they demonstrate the proper function of that dc trip path.

I maintain test reports on some of my Protection System components. Can I use these test reports to show that I have verified a maintenance activity?

Yes—the test reports may be used to demonstrate a verified maintenance activity.

References

1. [Protection System Maintenance: A Technical Reference](#). Prepared by the System Protection and Controls Task Force of the NERC Planning Committee. Dated September 13, 2007.
2. “Predicating The Optimum Routine test Interval For Protection Relays,” by J. J. Kumm, M.S. Weber, D. Hou, and E. O. Schweitzer, III, IEEE Transactions on Power Delivery, Vol. 10, No. 2, April 1995.
3. “Transmission Relay System Performance Comparison For 2000, 2001, 2002, 2003, 2004 and 2005,” Working Group I17 of Power System Relaying Committee of IEEE Power Engineering Society, May 2006.
4. “A Survey of Relaying Test Practices,” Special Report by WG I11 of Power System Relaying Committee of IEEE Power Engineering Society, September 16, 1999.
5. “Transmission Protective Relay System Performance Measuring Methodology,” Working Group I3 of Power System Relaying Committee of IEEE Power Engineering Society, January 2002.
6. “Processes, Issues, Trends and Quality Control of Relay Settings,” Working Group C3 of Power System Relaying Committee of IEEE Power Engineering Society, December 2006.
7. “Proposed Statistical Performance Measures for Microprocessor-Based Transmission-Line Protective Relays, Part I - Explanation of the Statistics, and Part II - Collection and Uses of Data,” Working Group D5 of Power System Relaying Committee of IEEE Power Engineering Society, May 1995; Papers 96WM 016-6 PWRD and 96WM 127-1 PWRD, 1996 IEEE Power Engineering Society Winter Meeting.
8. “Analysis And Guidelines For Testing Numerical Protection Schemes,” Final Report of CIGRE WG 34.10, August 2000.
9. “Use of Preventative Maintenance and System Performance Data to Optimize Scheduled Maintenance Intervals,” H. Anderson, R. Loughlin, and J. Zipp, Georgia Tech Protective Relay Conference, May 1996.
10. “Battery Performance Monitoring by Internal Ohmic Measurements” EPRI Application Guidelines for Stationary Batteries TR- 108826 Final Report, December 1997.
11. “IEEE Recommended Practice for Maintenance, Testing, and Replacement of Valve-Regulated Lead-Acid (VRLA) Batteries for Stationary Applications,” IEEE Power Engineering Society Std 1188 – 2005.

-
12. "IEEE Recommended Practice for Maintenance, Testing, and Replacement of Vented Lead-Acid Batteries for Stationary Applications," IEEE Power & Engineering Society Std 45-2010.
 13. "IEEE Recommended Practice for Installation design and Installation of Vented Lead-Acid Batteries for Stationary Applications," IEEE Std 484 – 2002.
 14. "Stationary Battery Monitoring by Internal Ohmic Measurements," EPRI Technical Report, 1002925 Final Report, December 2002.
 15. "Stationary Battery Guide: Design Application, and Maintenance" EPRI Revision 2 of TR-100248, 1006757, August 2002.

PSMT SDT References

16. "Essentials of Statistics for Business and Economics" Anderson, Sweeney, Williams, 2003
17. "Introduction to Statistics and Data Analysis" - Second Edition, Peck, Olson, Devore, 2005
18. "Statistical Analysis for Business Decisions" Peters, Summers, 1968
19. "Considerations for Maintenance and Testing of Autoreclosing Schemes," NERC System Analysis and Modeling Subcommittee and NERC System Protection and Control Subcommittee, November 2012

Figures

Figure 1: Typical Transmission System

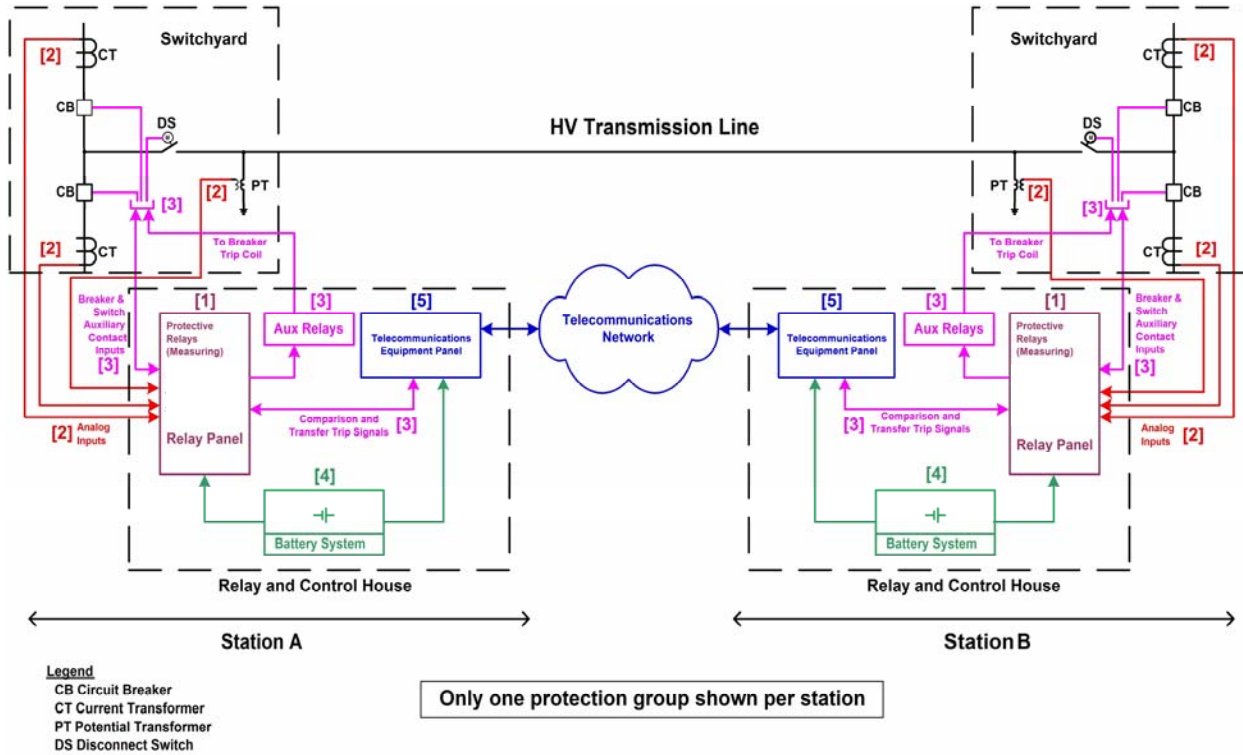

For information on components, see [Figure 1 & 2 Legend – components of Protection Systems](#)

Figure 2: Typical Generation System

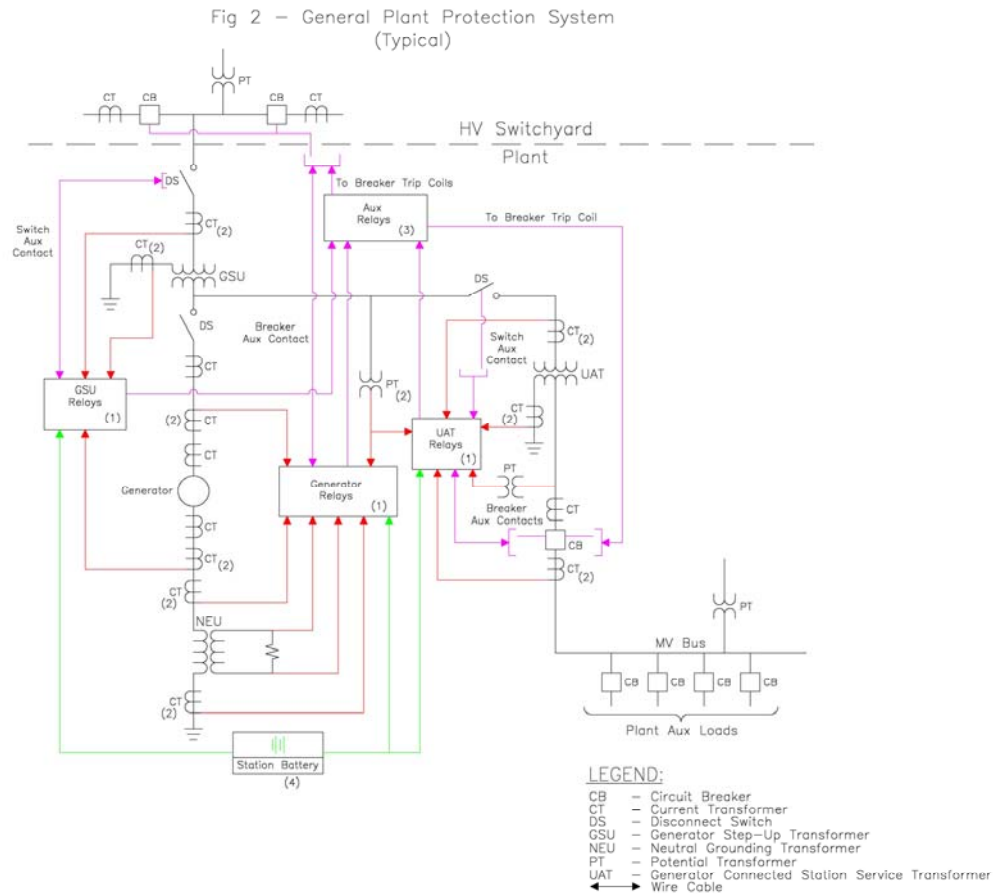

Note: Figure 2 may show elements that are not included within PRC-005-2, and also may not be all-inclusive; see the Applicability section of the standard for specifics.

For information on components, see [Figure 1 & 2 Legend – components of Protection Systems](#)

Figure 1 & 2 Legend – Components of Protection Systems

Number in Figure	Component of Protection System	Includes	Excludes
1	Protective relays which respond to electrical quantities	All protective relays that use current and/or voltage inputs from current & voltage sensors and that trip the 86, 94 or trip coil.	Devices that use non-electrical methods of operation including thermal, pressure, gas accumulation, and vibration. Any ancillary equipment not specified in the definition of Protection Systems. Control and/or monitoring equipment that is not a part of the automatic tripping action of the Protection System
2	Voltage and current sensing devices providing inputs to protective relays	The signals from the voltage & current sensing devices to the protective relay input.	Voltage & current sensing devices that are not a part of the Protection System, including sync-check systems, metering systems and data acquisition systems.
3	Control circuitry associated with protective functions	All control wiring (or other medium for conveying trip signals) associated with the tripping action of 86 devices, 94 devices or trip coils (from all parallel trip paths). This would include fiber-optic systems that carry a trip signal as well as hard-wired systems that carry trip current.	Closing circuits, SCADA circuits, other devices in control scheme not passing trip current
4	Station dc supply	Batteries and battery chargers and any control power system which has the function of supplying power to the protective relays, associated trip circuits and trip coils.	Any power supplies that are not used to power protective relays or their associated trip circuits and trip coils.
5	Communications systems necessary for correct operation of protective functions	Tele-protection equipment used to convey specific information, in the form of analog or digital signals, necessary for the correct operation of protective functions.	Any communications equipment that is not used to convey information necessary for the correct operation of protective functions.

[Additional information can be found in References](#)

Appendix A

The following illustrates the concept of overlapping verifications and tests as summarized in Section 10 of the paper. As an example, Figure A-1 shows protection for a critical transmission line by carrier blocking directional comparison pilot relaying. The goal is to verify the ability of the entire two-terminal pilot protection scheme to protect for line faults, and to avoid over-tripping for faults external to the transmission line zone of protection bounded by the current transformer locations.

Figure A-1

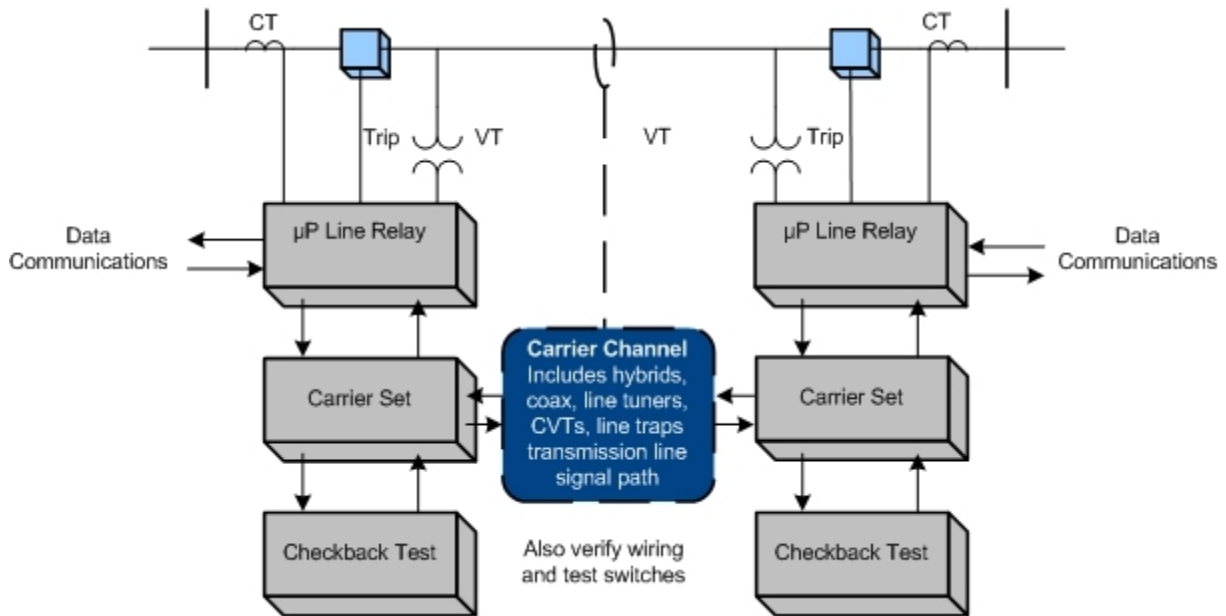

In this example (Figure A1), verification takes advantage of the self-monitoring features of microprocessor multifunction line relays at each end of the line. For each of the line relays themselves, the example assumes that the user has the following arrangements in place:

1. The relay has a data communications port that can be accessed from remote locations.
2. The relay has internal self-monitoring programs and functions that report failures of internal electronics, via communications messages or alarm contacts to SCADA.
3. The relays report loss of dc power, and the relays themselves or external monitors report the state of the dc battery supply.
4. The CT and PT inputs to the relays are used for continuous calculation of metered values of volts, amperes, plus ~~Watts-watts~~ and vars on the line. These metered values are reported by data communications. For maintenance, the user elects to compare these readings to those of other relays, meters, or DFRs. The other readings may be from redundant relaying or measurement systems or they may be derived from values in other protection zones. Comparison with other such readings to within required relaying accuracy verifies voltage and current sensing devices, wiring, and analog signal input processing of the relays. One effective way to do this is to utilize the relay metered values directly in SCADA, where they can be compared with other references or state estimator values.

5. Breaker status indication from auxiliary contacts is verified in the same way as in (2). Status indications must be consistent with the flow or absence of current.
6. Continuity of the breaker trip circuit from dc bus through the trip coil is monitored by the relay and reported via communications.
7. Correct operation of the on-off carrier channel is also critical to security of the Protection System, so each carrier set has a connected or integrated automatic checkback test unit. The automatic checkback test runs several times a day. Newer carrier sets with integrated checkback testing check for received signal level and report abnormal channel attenuation or noise, even if the problem is not severe enough to completely disable the channel.

These monitoring activities plus the check-back test comprise automatic verification of all the Protection System elements that experience tells us are the most prone to fail. But, does this comprise a complete verification?

Figure A-2

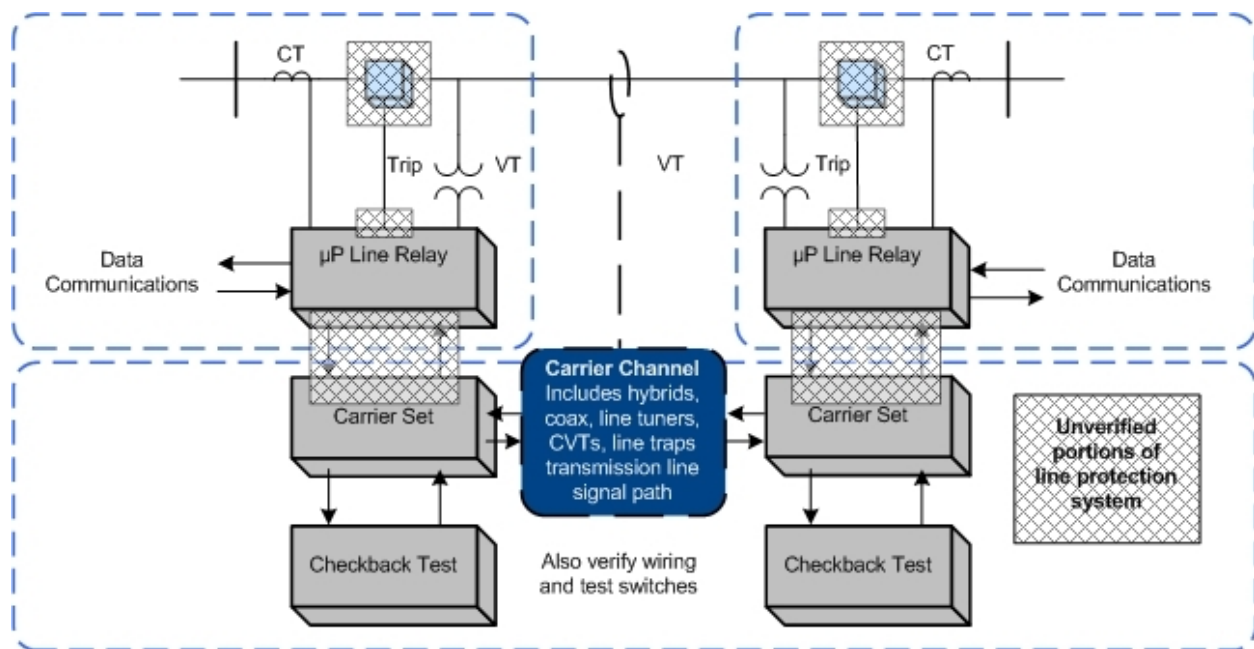

The dotted boxes of Figure A-2 show the sections of verification defined by the monitoring and verification practices just listed. These sections are not completely overlapping, and the shaded regions show elements that are not verified:

1. The continuity of trip coils is verified, but no means is provided for validating the ability of the circuit breaker to trip if the trip coil should be energized.
2. Within each line relay, all the microprocessors that participate in the trip decision have been verified by internal monitoring. However, the trip circuit is actually energized by the

contacts of a small telephone-type "ice cube" relay within the line protective relay. The microprocessor energizes the coil of this ice cube relay through its output data port and a transistor driver circuit. There is no monitoring of the output port, driver circuit, ice cube relay, or contacts of that relay. These components are critical for tripping the circuit breaker for a Fault.

3. The check-back test of the carrier channel does not verify the connections between the relaying microprocessor internal decision programs and the carrier transmitter keying circuit or the carrier receiver output state. These connections include microprocessor I/O ports, electronic driver circuits, wiring, and sometimes telephone-type auxiliary relays.
4. The correct states of breaker and disconnect switch auxiliary contacts are monitored, but this does not confirm that the state change indication is correct when the breaker or switch opens.

A practical solution for (1) and (2) is to observe actual breaker tripping, with a specified maximum time interval between trip tests. Clearing of naturally-occurring Faults are demonstrations of operation that reset the time interval clock for testing of each breaker tripped in this way. If Faults do not occur, manual tripping of the breaker through the relay trip output via data communications to the relay microprocessor meets the requirement for periodic testing.

PRC-005-6 does not address breaker maintenance, and its Protection System test requirements can be met by energizing the trip circuit in a test mode (breaker disconnected) through the relay microprocessor. This can be done via a front-panel button command to the relay logic, or application of a simulated Fault with a relay test set. However, utilities have found that breakers often show problems during Protection System tests. It is recommended that Protection System verification include periodic testing of the actual tripping of connected circuit breakers.

Testing of the relay-carrier set interface in (3) requires that each relay key its transmitter, and that the other relay demonstrate reception of that blocking carrier. This can be observed from relay or DFR records during naturally occurring Faults, or by a manual test. If the checkback test sequence were incorporated in the relay logic, the carrier sets and carrier channel are then included in the overlapping segments monitored by the two relays, and the monitoring gap is completely eliminated.

Appendix B

Protection System Maintenance Standard Drafting Team

Charles W. Rogers

Chairman

Consumers Energy Co.

John B. Anderson
Xcel Energy

Stephen Crutchfield
NERC

Forrest Brock
Western Farmers Electric Cooperative

John Schecter
American Electric Power

Aaron Feathers
Pacific Gas and Electric Company

William D. Shultz
Southern Company Generation

Sam Francis
Oncor Electric Delivery

Scott Vaughan
City of Roseville Electric Department

James M. Kinney
FirstEnergy Corporation

Matthew Westrich
American Transmission Company

Kristina Marriott
ENOSERV

Philip B. Winston
Southern Company Transmission

Consideration of Directives

Project 2007-17.4 – PRC-005 Order 803 Directive

October 9, 2015

Project 2007-17.4 – PRC-005 Order 803 Directive

Issue or Directive	Source	Consideration of Issue or Directive
<p>In Order No. 803, FERC approved Standard PRC-005-3 and, in Paragraph 31, directed NERC to:</p> <p>"...direct that, pursuant to section 215(d)(5) of the FPA, NERC develop modifications to PRC-005-3 to include supervisory devices associated with auto reclosing relay schemes to which the Reliability Standard applies. Further, we clarify that NERC's proposal regarding the scope of supervisory devices is an acceptable approach to satisfy the Commission directive. Specifically, NERC proposed in its NOPR comments, and we find acceptable, that the scope of the supervisory devices to be encompassed in the Reliability Standard are those providing voltage supervision, supervisory inputs associated with selective auto-reclosing, and sync-check relays that are part of a reclosing scheme covered by PRC-005-3."</p>	<p>FERC Order 803 approving Reliability Standard PRC-005-3, Protection System and , Automatic Reclosing Maintenance</p>	<p>The Protection System Maintenance and Testing Standard Drafting Team (PSMTSDT) proposed revision of the standard specific defined terms "Automatic Reclosing" and "Component Type" as follows:</p> <p>Automatic Reclosing – Includes the following Components:</p> <ul style="list-style-type: none"> • Reclosing relay(s) • Supervisory relay(s) or function(s)– relay(s) or function(s) that perform voltage and/or sync check functions that enables or disables operation of the reclosing relay • Voltage sensing devices associated with the supervisory relay(s) or function(s) • Control circuitry associated with the reclosing relay or supervisory relay(s) or function(s) <p>Component Type –</p>

Project 2007-17.4 – PRC-005 Order 803 Directive

Issue or Directive	Source	Consideration of Issue or Directive
		<ul style="list-style-type: none"> • Any one of the five specific elements of a Protection System. • Any one of the four specific elements of Automatic Reclosing. • Any one of the two specific elements of Sudden Pressure Relaying. <p>The Rationales for “Automatic Relaying” and “Component Type” were also revised to reflect the proposed revisions to the defined terms above. Tables 4-1 and 4-2 were updated by adding “supervisory relay(s)” as appropriate. A new Table 4-3 was added to address maintenance activities and intervals for Automatic Reclosing with supervisory relays. No substantive revisions are being proposed for the Requirements of the standard. The only revisions to Requirements R1 and R3 included updating the Table numbering to reflect the addition of Table 4-3. The Violation Severity Levels (VSLs) were updated to reflect the Requirement language for R1 and R3. All references to table numbering throughout the standard have also been corrected to reflect the addition of Table 4-3. This proposed version of PRC-005 used PRC-005-5 developed under Project 2014-01 as the starting point for revisions to address the directive.</p>

Consideration of Directives

Project 2007-17.4 – PRC-005 Order 803 Directive

~~July 14~~October 9, 2015

Project 2007-17.4 – PRC-005 Order 803 Directive

Issue or Directive	Source	Consideration of Issue or Directive
<p>In Order No. 803, FERC approved Standard PRC-005-3 and, in Paragraph 31, directed NERC to:</p> <p>"...direct that, pursuant to section 215(d)(5) of the FPA, NERC develop modifications to PRC-005-3 to include supervisory devices associated with auto-reclosing relay schemes to which the Reliability Standard applies. Further, we clarify that NERC's proposal regarding the scope of supervisory devices is an acceptable approach to satisfy the Commission directive. Specifically, NERC proposed in its NOPR comments, and we find acceptable, that the scope of the supervisory devices to be encompassed in the Reliability Standard are those providing voltage supervision, supervisory inputs associated with selective auto-reclosing, and sync-check relays that are part of a reclosing scheme covered by PRC-005-3."</p>	<p>FERC Order 803 approving Reliability Standard PRC-005-3, Protection System <u>and</u>, Automatic Reclosing, and Sudden Pressure Relaying Maintenance</p>	<p>The Protection System Maintenance and Testing Standard Drafting Team (PSMTSDT) proposed revision of the standard specific defined terms "Automatic Reclosing" and "Component Type" as follows:</p> <p>Automatic Reclosing – Includes the following Components:</p> <ul style="list-style-type: none"> • Reclosing relay(s) • <u>Supervisory relay(s) or function(s)– relay(s) or function(s) that perform voltage and/or sync check functions that enables or disables operation of the reclosing relay</u> • <u>Voltage sensing devices associated with the supervisory relay(s) or function(s)</u> • Control circuitry associated with the reclosing relay or supervisory relay(s) <u>or function(s)</u> <p>Component Type –</p>

Project 2007-17.4 – PRC-005 Order 803 Directive

Issue or Directive	Source	Consideration of Issue or Directive
		<ul style="list-style-type: none"> • Any one of the five specific elements of a Protection System. • Any one of the four^{two} specific elements of Automatic Reclosing. • Any one of the two specific elements of Sudden Pressure Relaying. <p>The Rationales for “Automatic Relaying” and “Component Type” were also revised to reflect the proposed revisions to the defined terms above. Tables 4-1 and 4-2 were updated by adding “supervisory relay(s)” as appropriate. A new Table 4-3 was added to address maintenance activities and intervals for Automatic Reclosing with supervisory relays. No substantive revisions are being proposed for the Requirements of the standard. The only revisions to Requirements R1 and R3 included updating the Table numbering to reflect the addition of Table 4-3. The Violation Severity Levels (VSLs) were updated to reflect the Requirement language for R1 and R3. All references to table numbering throughout the standard have also been corrected to reflect the addition of Table 4-3. This <u>proposed</u> version of PRC-005 used PRC-005-5 developed under Project 2014-01 as the starting point for revisions to address the directive.</p>

Standards Announcement

Project 2007-17.4 FERC Order No. 803 Directive
PRC-005-6

Final Ballot Open through October 26, 2015

[Now Available](#)

A final ballot for **PRC-005-6 – Protection System, Automatic Reclosing, and Sudden Pressure Relaying Maintenance** is open through **8 p.m. Eastern, Monday, October 26, 2015**.

Balloting

In the final ballot, votes are counted by exception. Only members of the ballot pool may cast a vote. All ballot pool members may change their previously cast vote. A ballot pool member who failed to vote during the previous ballot period may vote in the final ballot period. If a ballot pool member does not participate in the final ballot, the member's vote from the previous ballot will be carried over as their vote in the final ballot.

Members of the ballot pools associated with this project may log in and submit their vote by clicking [here](#).

If you are having difficulty accessing the SBS due to a forgotten password, incorrect credential error messages, or system lock-out, contact NERC IT support directly at EROhelpdesk@nerc.net (Monday – Friday, 8 a.m. - 8 p.m. Eastern).

Next Steps

The voting results for the standard will be posted and announced after the ballot closes. If approved, the standard will be submitted to the Board of Trustees for adoption and then filed with the appropriate regulatory authorities.

Standards Development Process

For more information on the Standards Development Process, refer to the [Standard Processes Manual](#).

For more information or assistance, contact Senior Standards Developer, [Stephen Crutchfield](#) (via email), or at (609) 651-9455.

North American Electric Reliability Corporation
3353 Peachtree Rd, NE
Suite 600, North Tower
Atlanta, GA 30326
404-446-2560 | www.nerc.com

Standards Announcement

Project 2007-17.4 FERC Order No. 803 Directive
PRC-005-6

Final Ballot Results

[Now Available](#)

A final ballot for **PRC-005-6 – Protection System, Automatic Reclosing, and Sudden Pressure Relaying Maintenance** concluded **8 p.m. Eastern, Monday, October 26, 2015.**

The standard received sufficient affirmative votes for approval. Voting statistics are listed below, and the [Ballot Results](#) page provides the detailed results.

Ballot
Quorum / Approval
90.00% / 96.38%

Next Steps

The standard will be submitted to the Board of Trustees for adoption and then filed with the appropriate regulatory authorities.

Standards Development Process

For more information on the Standards Development Process, refer to the [Standard Processes Manual](#).

For more information or assistance, contact Senior Standards Developer, [Stephen Crutchfield](#) (via email), or at (609) 651-9455.

North American Electric Reliability Corporation

3353 Peachtree Rd, NE

Suite 600, North Tower

Atlanta, GA 30326

404-446-2560 | www.nerc.com

NERC Balloting Tool (/)

[Dashboard \(/\)](#)
[Users](#)
[Ballots](#)
[Surveys](#)
[Legacy SBS \(https://standards.nerc.net/\)](https://standards.nerc.net/)
[Login \(/Users/Login\)](/Users/Login/) / [Register \(/Users/Register\)](/Users/Register/)

BALLOT RESULTS

Ballot Name: 2007-17.4 PRC-005 FERC Order No. 803 Directive PRC-005-6 FN 2 ST

Voting Start Date: 10/15/2015 10:57:26 AM

Voting End Date: 10/26/2015 8:00:00 PM

Ballot Type: ST

Ballot Activity: FN

Ballot Series: 2

Total # Votes: 297

Total Ballot Pool: 330

Quorum: 90

Weighted Segment Value: 96.38

Segment	Ballot Pool	Segment Weight	Affirmative Votes	Affirmative Fraction	Negative Votes w/ Comment	Negative Fraction w/ Comment	Negative Votes w/o Comment	Abstain	No Vote
Segment: 1	81	1	68	0.971	2	0.029	0	3	8
Segment: 2	8	0.5	5	0.5	0	0	0	1	2
Segment: 3	76	1	60	0.984	1	0.016	0	6	9
Segment: 4	26	1	20	0.952	1	0.048	0	0	5
Segment: 5	80	1	67	0.971	2	0.029	0	5	6
Segment: 6	45	1	40	0.976	1	0.024	0	1	3
Segment: 7	2	0.1	1	0.1	0	0	0	1	0
Segment: 8	2	0.2	2	0.2	0	0	0	0	0
Segment: 9	2	0.2	2	0.2	0	0	0	0	0

Segment: 10	8	0.8	7	0.7	1	0.1	0	0	0
Totals:	330	6.8	272	6.554	8	0.246	0	17	33

BALLOT POOL MEMBERS

Show entries

Search:

Segment	Organization	Voter	Designated Proxy	Ballot	NERC Memo
1	Ameren - Ameren Services	Eric Scott		Affirmative	N/A
1	American Transmission Company, LLC	Andrew Pusztai		Affirmative	N/A
1	APS - Arizona Public Service Co.	Michelle Amarantos		Affirmative	N/A
1	Associated Electric Cooperative, Inc.	Phil Hart		Affirmative	N/A
1	Avista - Avista Corporation	Bryan Cox	Rich Hydzik	Affirmative	N/A
1	Balancing Authority of Northern California	Kevin Smith	Joe Tarantino	Affirmative	N/A
1	BC Hydro and Power Authority	Patricia Robertson		Affirmative	N/A
1	Beaches Energy Services	Don Cuevas		Affirmative	N/A
1	Berkshire Hathaway Energy - MidAmerican Energy Co.	Terry Harbour		Affirmative	N/A
1	Black Hills Corporation	Wes Wingen		Abstain	N/A

1	Bonneville Power Administration	Donald Watkins		Affirmative	N/A
1	Brazos Electric Power Cooperative, Inc.	Tony Kroskey		None	N/A
1	Bryan Texas Utilities	John Fontenot		Affirmative	N/A
1	CenterPoint Energy Houston Electric, LLC	John Brockhan		Affirmative	N/A
1	Central Electric Power Cooperative (Missouri)	Michael Bax		None	N/A
1	Cleco Corporation	John Lindsey	Louis Guidry	Affirmative	N/A
1	Colorado Springs Utilities	Shawna Speer		Affirmative	N/A
1	Con Ed - Consolidated Edison Co. of New York	Chris de Graffenried		Affirmative	N/A
1	Dairyland Power Cooperative	Robert Roddy		Affirmative	N/A
1	Dominion - Dominion Virginia Power	Larry Nash		Affirmative	N/A
1	Duke Energy	Doug Hils		Affirmative	N/A
1	East Kentucky Power Cooperative	Amber Skillern		Affirmative	N/A
1	Edison International - Southern California Edison Company	Steven Mavis		Affirmative	N/A
1	Entergy - Entergy Services, Inc.	Oliver Burke		Affirmative	N/A
1	Exelon	Chris Scanlon		Affirmative	N/A
1	FirstEnergy - FirstEnergy Corporation	William Smith		Affirmative	N/A
1	Georgia Transmission Corporation	Jason Snodgrass		Affirmative	N/A
1	Great Plains Energy - Kansas City Power and Light Co.	James McBee	Douglas Webb	Affirmative	N/A

1	Great River Energy	Gordon Pietsch		Affirmative	N/A
1	Hoosier Energy Rural Electric Cooperative, Inc.	Bob Solomon		None	N/A
1	Hydro One Networks, Inc.	Payam Farahbakhsh	Oshani Pathirane	Affirmative	N/A
1	Hydro-Qu?bec TransEnergie	Martin Boisvert		Affirmative	N/A
1	IDACORP - Idaho Power Company	Molly Devine		Affirmative	N/A
1	International Transmission Company Holdings Corporation	Michael Moltane	Meghan Ferguson	Affirmative	N/A
1	KAMO Electric Cooperative	Walter Kenyon		Affirmative	N/A
1	Los Angeles Department of Water and Power	faranak sarbaz		Affirmative	N/A
1	Lower Colorado River Authority	Teresa Cantwell		Affirmative	N/A
1	M and A Electric Power Cooperative	William Price		Affirmative	N/A
1	Manitoba Hydro	Mike Smith		Negative	N/A
1	MEAG Power	David Weekley	Scott Miller	None	N/A
1	Muscatine Power and Water	Andy Kurriger		Affirmative	N/A
1	N.W. Electric Power Cooperative, Inc.	Mark Ramsey		Affirmative	N/A
1	National Grid USA	Michael Jones		Affirmative	N/A
1	NB Power Corporation	Alan MacNaughton		Affirmative	N/A
1	Nebraska Public Power District	Jamison Cawley		Affirmative	N/A
1	New York Power Authority	Salvatore Spagnolo		Affirmative	N/A
1	NextEra Energy - Florida Power and	Mike ONeil		Affirmative	N/A

	Light Co.				
1	NiSource - Northern Indiana Public Service Co.	Robert Fox		Affirmative	N/A
1	Northeast Missouri Electric Power Cooperative	Kevin White		Affirmative	N/A
1	NorthWestern Energy	Belinda Tierney		None	N/A
1	OGE Energy - Oklahoma Gas and Electric Co.	Terri Pyle		Affirmative	N/A
1	Oncor Electric Delivery	Rod Kinard	Gul Khan	Affirmative	N/A
1	OTP - Otter Tail Power Company	Charles Wicklund		Affirmative	N/A
1	Peak Reliability	Jared Shakespeare		Abstain	N/A
1	PHI - Potomac Electric Power Co.	David Thorne		Affirmative	N/A
1	Platte River Power Authority	John Collins		Affirmative	N/A
1	PNM Resources - Public Service Company of New Mexico	Laurie Williams		Affirmative	N/A
1	PPL Electric Utilities Corporation	Brenda Truhe		Affirmative	N/A
1	PSEG - Public Service Electric and Gas Co.	Joseph Smith		Negative	N/A
1	Public Utility District No. 1 of Snohomish County	Long Duong		Affirmative	N/A
1	Public Utility District No. 2 of Grant County, Washington	Michiko Sell		Affirmative	N/A
1	Sacramento Municipal Utility District	Tim Kelley	Joe Tarantino	Affirmative	N/A
1	Salt River Project	Steven Cobb		None	N/A
1	Santee Cooper	Shawn Abrams		Affirmative	N/A

1	SCANA - South Carolina Electric and Gas Co.	Tom Hanzlik		Affirmative	N/A
1	Seattle City Light	Pawel Krupa		Affirmative	N/A
1	Seminole Electric Cooperative, Inc.	Mark Churilla	Bret Galbraith	Affirmative	N/A
1	Sho-Me Power Electric Cooperative	Denise Stevens		Affirmative	N/A
1	Southern Company - Southern Company Services, Inc.	Robert A. Schaffeld		Affirmative	N/A
1	Southern Indiana Gas and Electric Co.	Steve Rawlinson		Affirmative	N/A
1	Southwest Transmission Cooperative, Inc.	John Shaver		Affirmative	N/A
1	Tacoma Public Utilities (Tacoma, WA)	John Merrell		Affirmative	N/A
1	Tallahassee Electric (City of Tallahassee, FL)	Scott Langston		Affirmative	N/A
1	Tennessee Valley Authority	Howell Scott		Abstain	N/A
1	Tri-State G and T Association, Inc.	Tracy Sliman		Affirmative	N/A
1	Unisource - Tucson Electric Power Co.	John Tolo		Affirmative	N/A
1	United Illuminating Co.	Jonathan Appelbaum		Affirmative	N/A
1	VELCO -Vermont Electric Power Company, Inc.	Kim Moulton		None	N/A
1	Westar Energy	Kevin Giles		Affirmative	N/A
1	Western Area Power Administration	Steve Johnson		None	N/A
1	Xcel Energy, Inc.	Dean Schiro		Affirmative	N/A
2	BC Hydro and Power Authority	Venkataramakrishnan Vinnakota		Affirmative	N/A

2	Electric Reliability Council of Texas, Inc.	Elizabeth Axson		Abstain	N/A
2	Herb Schrayshuen	Herb Schrayshuen		Affirmative	N/A
2	Independent Electricity System Operator	Leonard Kula		Affirmative	N/A
2	Midcontinent ISO, Inc.	Terry Blilke		None	N/A
2	New York Independent System Operator	Gregory Campoli		None	N/A
2	PJM Interconnection, L.L.C.	Mark Holman		Affirmative	N/A
2	Southwest Power Pool, Inc. (RTO)	Charles Yeung		Affirmative	N/A
3	Ameren - Ameren Services	David Jendras		Affirmative	N/A
3	Anaheim Public Utilities Dept.	Dennis Schmidt		Abstain	N/A
3	APS - Arizona Public Service Co.	Jeri Freimuth		Affirmative	N/A
3	Associated Electric Cooperative, Inc.	Todd Bennett		Affirmative	N/A
3	Austin Energy	Shuye Teng		Affirmative	N/A
3	Avista - Avista Corporation	Scott Kinney		None	N/A
3	Basin Electric Power Cooperative	Jeremy Voll		Affirmative	N/A
3	BC Hydro and Power Authority	Pat Harrington		Affirmative	N/A
3	Beaches Energy Services	Steven Lancaster		Affirmative	N/A
3	Berkshire Hathaway Energy - MidAmerican Energy Co.	Thomas Mielnik	Darnez Gresham	Affirmative	N/A
3	Bonneville Power Administration	Rebecca Berdahl		Affirmative	N/A
3	Central Electric Power	Adam Weber		Affirmative	N/A

	Cooperative (Missouri)				
3	City of Green Cove Springs	Mark Schultz		Affirmative	N/A
3	City of Leesburg	Chris Adkins		Affirmative	N/A
3	City of Redding	Elizabeth Hadley	Bill Hughes	Affirmative	N/A
3	Clark Public Utilities	Jack Stamper		Affirmative	N/A
3	Cleco Corporation	Michelle Corley	Louis Guidry	Affirmative	N/A
3	CMS Energy - Consumers Energy Company	Karl Blaszkowski		Affirmative	N/A
3	Colorado Springs Utilities	Charles Morgan		None	N/A
3	Con Ed - Consolidated Edison Co. of New York	Peter Yost		Affirmative	N/A
3	Dominion - Dominion Resources, Inc.	Connie Lowe		Affirmative	N/A
3	DTE Energy - Detroit Edison Company	Kent Kujala		Affirmative	N/A
3	Duke Energy	Lee Schuster		Affirmative	N/A
3	East Kentucky Power Cooperative	Patrick Woods		None	N/A
3	Edison International - Southern California Edison Company	Romel Aquino		Affirmative	N/A
3	Exelon	John Bee		Affirmative	N/A
3	FirstEnergy - FirstEnergy Corporation	Theresa Ciancio		Affirmative	N/A
3	Florida Municipal Power Agency	Joe McKinney		Affirmative	N/A
3	Georgia System Operations Corporation	Scott McGough		Affirmative	N/A
3	Grand River Dam Authority	Jeff Wells		Abstain	N/A

3	Great Plains Energy - Kansas City Power and Light Co.	Jessica Tucker	Douglas Webb	Affirmative	N/A
3	Great River Energy	Brian Glover		Affirmative	N/A
3	Hydro One Networks, Inc.	Paul Malozewski	Oshani Pathirane	Affirmative	N/A
3	JEA	Garry Baker		Affirmative	N/A
3	KAMO Electric Cooperative	Ted Hilmes		Affirmative	N/A
3	Lakeland Electric	Mace Hunter		Affirmative	N/A
3	Lincoln Electric System	Jason Fortik		Abstain	N/A
3	Los Angeles Department of Water and Power	Mike Ancil		Affirmative	N/A
3	M and A Electric Power Cooperative	Stephen Pogue		Affirmative	N/A
3	Manitoba Hydro	Karim Abdel-Hadi		Negative	N/A
3	MEAG Power	Roger Brand	Scott Miller	None	N/A
3	Modesto Irrigation District	Jack Savage	Nick Braden	Affirmative	N/A
3	Muscatine Power and Water	Seth Shoemaker		Affirmative	N/A
3	National Grid USA	Brian Shanahan		Affirmative	N/A
3	Nebraska Public Power District	Tony Eddleman		Affirmative	N/A
3	New York Power Authority	David Rivera		Affirmative	N/A
3	NiSource - Northern Indiana Public Service Co.	Ramon Barany		Affirmative	N/A
3	North Carolina Electric Membership Corporation	doug white	Scott Brame	Affirmative	N/A
3	Northeast Missouri Electric Power	Skyler Wiegmann		None	N/A

	Cooperative				
3	NW Electric Power Cooperative, Inc.	John Stickley		Affirmative	N/A
3	OGE Energy - Oklahoma Gas and Electric Co.	Donald Hargrove		Affirmative	N/A
3	PHI - Potomac Electric Power Co.	Mark Yerger		Affirmative	N/A
3	PNM Resources	Michael Mertz		Affirmative	N/A
3	PPL - Louisville Gas and Electric Co.	Charles Freibert		Affirmative	N/A
3	PSEG - Public Service Electric and Gas Co.	Jeffrey Mueller		None	N/A
3	Public Utility District No. 1 of Okanogan County	Dale Dunckel		None	N/A
3	Puget Sound Energy, Inc.	Andrea Basinski		Abstain	N/A
3	Rutherford EMC	Tom Haire		Abstain	N/A
3	Sacramento Municipal Utility District	Rachel Moore	Joe Tarantino	Affirmative	N/A
3	Salt River Project	John Coggins		Affirmative	N/A
3	Santee Cooper	James Poston		Affirmative	N/A
3	SCANA - South Carolina Electric and Gas Co.	Clay Young		Affirmative	N/A
3	Seattle City Light	Dana Wheelock		Affirmative	N/A
3	Seminole Electric Cooperative, Inc.	James Frauen		Affirmative	N/A
3	Sho-Me Power Electric Cooperative	Jeff Neas		None	N/A
3	Snohomish County PUD No. 1	Mark Oens		Affirmative	N/A
3	Southern Company - Alabama Power Company	R. Scott Moore		Affirmative	N/A

3	Southern Indiana Gas and Electric Co.	Jim Cox		Affirmative	N/A
3	Tacoma Public Utilities (Tacoma, WA)	Marc Donaldson		Affirmative	N/A
3	Tallahassee Electric (City of Tallahassee, FL)	John Williams		Affirmative	N/A
3	TECO - Tampa Electric Co.	Ronald Donahey		None	N/A
3	Tennessee Valley Authority	Ian Grant		Abstain	N/A
3	Tri-State G and T Association, Inc.	Janelle Marriott Gill		Affirmative	N/A
3	WEC Energy Group, Inc.	James Keller		Affirmative	N/A
3	Westar Energy	Bo Jones		Affirmative	N/A
3	Xcel Energy, Inc.	Michael Ibold		Affirmative	N/A
4	Alliant Energy Corporation Services, Inc.	Kenneth Goldsmith		Affirmative	N/A
4	Austin Energy	Tina Garvey		Affirmative	N/A
4	Blue Ridge Power Agency	Duane Dahlquist		Affirmative	N/A
4	City of Clewiston	Lynne Mila		Affirmative	N/A
4	City of New Smyrna Beach Utilities Commission	Tim Beyrle		Affirmative	N/A
4	City of Redding	Nick Zettel	Bill Hughes	Affirmative	N/A
4	CMS Energy - Consumers Energy Company	Julie Hegedus		None	N/A
4	DTE Energy - Detroit Edison Company	Daniel Herring		Affirmative	N/A
4	FirstEnergy - Ohio Edison Company	Doug Hohlbaugh		Affirmative	N/A
4	Florida Municipal	Carol Chinn		Affirmative	N/A

	Power Agency				
4	Georgia System Operations Corporation	Guy Andrews		None	N/A
4	Illinois Municipal Electric Agency	Bob Thomas		Affirmative	N/A
4	Keys Energy Services	Stanley Rzad		Affirmative	N/A
4	MGE Energy - Madison Gas and Electric Co.	Joseph DePoorter		Affirmative	N/A
4	Modesto Irrigation District	Spencer Tacke		None	N/A
4	North Carolina Electric Membership Corporation	John Lemire	Scott Brame	Affirmative	N/A
4	Oklahoma Municipal Power Authority	Ashley Stringer		Affirmative	N/A
4	Public Utility District No. 1 of Snohomish County	John Martinsen		Affirmative	N/A
4	Public Utility District No. 2 of Grant County, Washington	Yvonne McMackin		Affirmative	N/A
4	Sacramento Municipal Utility District	Michael Ramirez	Joe Tarantino	Affirmative	N/A
4	Seattle City Light	Hao Li		Affirmative	N/A
4	Seminole Electric Cooperative, Inc.	Michael Ward		Affirmative	N/A
4	South Mississippi Electric Power Association	Steve McElhaney		None	N/A
4	Tacoma Public Utilities (Tacoma, WA)	Hien Ho		Affirmative	N/A
4	Utility Services, Inc.	Brian Evans-Mongeon		None	N/A
4	WEC Energy Group, Inc.	Anthony Jankowski		Negative	N/A
5	AEP	Thomas Foltz		Affirmative	N/A

5	Ameren - Ameren Missouri	Sam Dwyer		Affirmative	N/A
5	APS - Arizona Public Service Co.	Stephanie Little		Affirmative	N/A
5	Associated Electric Cooperative, Inc.	Matthew Pacobit		Affirmative	N/A
5	Austin Energy	Jeanie Doty		Affirmative	N/A
5	Avista - Avista Corporation	Steve Wenke		Affirmative	N/A
5	Basin Electric Power Cooperative	Mike Kraft		Affirmative	N/A
5	BC Hydro and Power Authority	Clement Ma		Affirmative	N/A
5	Berkshire Hathaway - NV Energy	Eric Schwarzrock		Affirmative	N/A
5	Boise-Kuna Irrigation District - Lucky Peak Power Plant Project	Mike Kukla		Affirmative	N/A
5	Bonneville Power Administration	Francis Halpin		Affirmative	N/A
5	Brazos Electric Power Cooperative, Inc.	Shari Heino		Affirmative	N/A
5	Calpine Corporation	Hamid Zakery		Affirmative	N/A
5	Choctaw Generation Limited Partnership, LLLP	Rob Watson		Affirmative	N/A
5	City and County of San Francisco	Daniel Mason		Abstain	N/A
5	City of Independence, Power and Light Department	Jim Nail		Affirmative	N/A
5	City of Redding	Paul Cummings	Bill Hughes	Affirmative	N/A
5	Cleco Corporation	Stephanie Huffman	Louis Guidry	Affirmative	N/A
5	CMS Energy - Consumers Energy Company	David Greyerbiehl		Affirmative	N/A

5	Cogentrix Energy Power Management, LLC	Mike Hirst		Affirmative	N/A
5	Colorado Springs Utilities	Jeff Icke		Affirmative	N/A
5	Con Ed - Consolidated Edison Co. of New York	Brian O'Boyle		Affirmative	N/A
5	Dairyland Power Cooperative	Tommy Drea		Affirmative	N/A
5	Dominion - Dominion Resources, Inc.	Randi Heise		Affirmative	N/A
5	DTE Energy - Detroit Edison Company	Jeffrey DePriest		Affirmative	N/A
5	Duke Energy	Dale Goodwine		Affirmative	N/A
5	Dynegy Inc.	Dan Roethemeyer		Affirmative	N/A
5	East Kentucky Power Cooperative	Steve Ricker		Affirmative	N/A
5	Edison International - Southern California Edison Company	Michael McSpadden		Affirmative	N/A
5	Entergy - Entergy Services, Inc.	Tracey Stubbs		None	N/A
5	Essential Power, LLC	Gerry Adamski		Affirmative	N/A
5	Exelon	Vince Catania		Affirmative	N/A
5	FirstEnergy - FirstEnergy Solutions	Robert Loy		Affirmative	N/A
5	Florida Municipal Power Agency	David Schumann		Affirmative	N/A
5	Great Plains Energy - Kansas City Power and Light Co.	Harold Wyble	Douglas Webb	Affirmative	N/A
5	Great River Energy	Preston Walsh		Affirmative	N/A
5	Hydro-Quebec Production	Roger Dufresne		Affirmative	N/A
5	JEA	John Babik		Affirmative	N/A

5	Lakeland Electric	Jim Howard		None	N/A
5	Lincoln Electric System	Kayleigh Wilkerson		Abstain	N/A
5	Los Angeles Department of Water and Power	Kenneth Silver		Affirmative	N/A
5	Lower Colorado River Authority	Dixie Wells		Affirmative	N/A
5	Luminant - Luminant Generation Company LLC	Rick Terrill		Affirmative	N/A
5	Manitoba Hydro	Yuguang Xiao		Negative	N/A
5	Massachusetts Municipal Wholesale Electric Company	David Gordon		Affirmative	N/A
5	MEAG Power	Steven Grego	Scott Miller	None	N/A
5	Muscatine Power and Water	Mike Avesing		Affirmative	N/A
5	NB Power Corporation	Rob Vance		Affirmative	N/A
5	Nebraska Public Power District	Don Schmit		Affirmative	N/A
5	New York Power Authority	Wayne Sipperly		Affirmative	N/A
5	NextEra Energy	Allen Schriver		Affirmative	N/A
5	NiSource - Northern Indiana Public Service Co.	Michael Melvin		Affirmative	N/A
5	North Carolina Electric Membership Corporation	Robert Beadle	Scott Brame	Affirmative	N/A
5	OGE Energy - Oklahoma Gas and Electric Co.	Leo Staples		Affirmative	N/A
5	Oglethorpe Power Corporation	Bernard Johnson		None	N/A
5	Omaha Public Power District	Mahmood Safi		Affirmative	N/A

5	OTP - Otter Tail Power Company	Cathy Fogale		Affirmative	N/A
5	Oxy - Ingleside Cogeneration LP	Michelle D'Antuono		Affirmative	N/A
5	Pacific Gas and Electric Company	Alex Chua		Abstain	N/A
5	Platte River Power Authority	Tyson Archie		Affirmative	N/A
5	Portland General Electric Co.	Matt Jastram		None	N/A
5	PPL Electric Utilities Corporation	Dan Wilson		Affirmative	N/A
5	PSEG - PSEG Fossil LLC	Tim Kucey		Negative	N/A
5	Public Utility District No. 1 of Snohomish County	Sam Nietfeld		Affirmative	N/A
5	Public Utility District No. 2 of Grant County, Washington	Alex Ybarra		Affirmative	N/A
5	Puget Sound Energy, Inc.	Lynda Kupfer		Abstain	N/A
5	Sacramento Municipal Utility District	Susan Gill-Zobitz	Joe Tarantino	Affirmative	N/A
5	Salt River Project	Kevin Nielsen		Affirmative	N/A
5	SCANA - South Carolina Electric and Gas Co.	Edward Magic		Affirmative	N/A
5	Seattle City Light	Mike Haynes		Affirmative	N/A
5	Southern Company - Southern Company Generation	William D. Shultz		Affirmative	N/A
5	Southern Indiana Gas and Electric Co.	Scotty Brown	Rob Collins	Affirmative	N/A
5	Tacoma Public Utilities (Tacoma, WA)	Chris Mattson		Affirmative	N/A

5	Talen Generation, LLC	Donald Lock		Affirmative	N/A
5	Tallahassee Electric (City of Tallahassee, FL)	Karen Webb		Affirmative	N/A
5	TECO - Tampa Electric Co.	R James Rocha		None	N/A
5	Tennessee Valley Authority	Brandy Spraker		Abstain	N/A
5	WEC Energy Group, Inc.	Linda Horn		Affirmative	N/A
5	Westar Energy	stephanie johnson		Affirmative	N/A
5	Xcel Energy, Inc.	David Lemmons		Affirmative	N/A
6	Ameren - Ameren Services	Robert Quinlivan		Affirmative	N/A
6	APS - Arizona Public Service Co.	Bobbi Welch		Affirmative	N/A
6	Associated Electric Cooperative, Inc.	Brian Ackermann		Affirmative	N/A
6	Austin Energy	Andrew Gallo		Affirmative	N/A
6	Berkshire Hathaway - PacifiCorp	Sandra Shaffer		Affirmative	N/A
6	Bonneville Power Administration	Alex Spain		Affirmative	N/A
6	City of Redding	Marvin Briggs	Bill Hughes	Affirmative	N/A
6	Cleco Corporation	Robert Hirchak	Louis Guidry	Affirmative	N/A
6	Colorado Springs Utilities	Shannon Fair		Affirmative	N/A
6	Con Ed - Consolidated Edison Co. of New York	Robert Winston		Affirmative	N/A
6	Dominion - Dominion Resources, Inc.	Louis Slade		Affirmative	N/A
6	Duke Energy	Greg Cecil		Affirmative	N/A
6	Exelon	Dave Carlson		Affirmative	N/A

6	FirstEnergy - FirstEnergy Solutions	Ann Ivanc	Richard Hoag	Affirmative	N/A
6	Florida Municipal Power Agency	Richard Montgomery		Affirmative	N/A
6	Florida Municipal Power Pool	Tom Reedy		Affirmative	N/A
6	Great Plains Energy - Kansas City Power and Light Co.	Chris Bridges	Douglas Webb	Affirmative	N/A
6	Great River Energy	Donna Stephenson	Michael Brytowski	Affirmative	N/A
6	Lower Colorado River Authority	Michael Shaw		Affirmative	N/A
6	Manitoba Hydro	Blair Mukanik		Negative	N/A
6	Modesto Irrigation District	James McFall	Nick Braden	Affirmative	N/A
6	Muscatine Power and Water	Ryan Streck		Affirmative	N/A
6	New York Power Authority	Shivaz Chopra		Affirmative	N/A
6	NextEra Energy - Florida Power and Light Co.	Silvia Mitchell		Affirmative	N/A
6	NiSource - Northern Indiana Public Service Co.	Joe O'Brien		Affirmative	N/A
6	OGE Energy - Oklahoma Gas and Electric Co.	Jerry Nottnagel		None	N/A
6	Oglethorpe Power Corporation	Donna Johnson		None	N/A
6	Platte River Power Authority	Carol Ballantine		Affirmative	N/A
6	Portland General Electric Co.	Shawn Davis		Affirmative	N/A
6	PPL - Louisville Gas and Electric Co.	OELKER LINN		Affirmative	N/A

6	Sacramento Municipal Utility District	Diane Clark	Joe Tarantino	Affirmative	N/A
6	Salt River Project	William Abraham	Chris Janick	Affirmative	N/A
6	Santee Cooper	Michael Brown		Affirmative	N/A
6	Seattle City Light	Charles Freeman		Affirmative	N/A
6	Seminole Electric Cooperative, Inc.	Trudy Novak		Affirmative	N/A
6	Snohomish County PUD No. 1	Kenn Backholm		Affirmative	N/A
6	Southern Company - Southern Company Generation and Energy Marketing	John J. Ciza		Affirmative	N/A
6	Southern Indiana Gas and Electric Co.	Brad Lisembee		Affirmative	N/A
6	Tacoma Public Utilities (Tacoma, WA)	Rick Applegate		Affirmative	N/A
6	Talen Energy Marketing, LLC	Elizabeth Davis		Affirmative	N/A
6	TECO - Tampa Electric Co.	Benjamin Smith		None	N/A
6	Tennessee Valley Authority	Marjorie Parsons		Abstain	N/A
6	WEC Energy Group, Inc.	David Hathaway		Affirmative	N/A
6	Westar Energy	Megan Wagner		Affirmative	N/A
6	Xcel Energy, Inc.	Peter Colussy		Affirmative	N/A
7	Exxon Mobil	Jay Barnett		Abstain	N/A
7	Luminant Mining Company LLC	Stewart Rake		Affirmative	N/A
8	David Kiguel	David Kiguel		Affirmative	N/A
8	Massachusetts Attorney General	Frederick Plett		Affirmative	N/A
9	City of Vero Beach	Ginny Beigel		Affirmative	N/A
9	Commonwealth of	Donald Nelson		Affirmative	N/A

	Massachusetts Department of Public Utilities				
10	Florida Reliability Coordinating Council	Peter Heidrich		Affirmative	N/A
10	Midwest Reliability Organization	Russel Mountjoy		Affirmative	N/A
10	Northeast Power Coordinating Council	Guy V. Zito		Affirmative	N/A
10	ReliabilityFirst	Anthony Jablonski		Affirmative	N/A
10	SERC Reliability Corporation	David Greene		Affirmative	N/A
10	Southwest Power Pool Regional Entity	Bob Reynolds		Affirmative	N/A
10	Texas Reliability Entity, Inc.	Rachel Coyne		Negative	N/A
10	Western Electricity Coordinating Council	Steven Rueckert		Affirmative	N/A

Previous

1

Next

Showing 1 to 330 of 330 entries

Exhibit J

Standard Drafting Team Rosters

Reliability Standard PRC-005-5 SDT Roster

Standards Drafting Team Roster

Project 2014-01 Standards Applicability for Dispersed Generation Resources Standards Drafting Team

	Participant	Entity
Chair	Tony Jankowski	We Energies
Vice Chair	Tom Pruitt	Duke Energy
Member	David Belanger	Exelon Generation
Member	George Brown	Acciona Energy North America
Member	Brian Evans-Mongeon	Utility Services, Inc.
Member	Jessie Nevarez	Terra-Gen Operating Company
Member	Jeffrey Plew	NextEra Energy Resources
Member	Randhir Singh	PSEG Fossil
Member	Eric White	MidAmerican Energy
NERC Staff	Katherine Street (Lead Standards Developer)	NERC
NERC Staff	Laura Anderson (Supporting Standards Developer)	NERC
NERC Staff	Sean Cavote (Manager Standards Development)	NERC
NERC Staff	Stephen Crutchfield (NERC Staff SME)	NERC
NERC Staff	Andrew Wills (NERC Legal)	NERC
PMOS	Jennifer Sterling	Exelon
FERC	Susan Morris	FERC
FERC	Tom Bradish	FERC

Version	Date	Description
1.0		Initial posting
2.0		Removed Members: Dana Showalter, resigned to pursue education; Stephen Enyeart, resigned due to retirement. Removed PMOS Representative Gary Kruempel and replaced with Jennifer Sterling. Added NERC Staff Stephen Crutchfield and Andrew Wills.

Reliability Standard PRC-005-6 SDT Roster

Standards Drafting Team Roster

Project 2007-17.4 PRC-005 Order No. 803 Directive

Name and Title	Company and Address	Contact Info	Bio
Charles W. Rogers Principal Engineer	Consumers Energy 1945 W. Parnall Road Jackson, Michigan 49201	(517) 788-0027 (517) 788-0917 Fx Charles.Rogers@ cmsenergy.com	<p>Charles Rogers is a Principal Engineer for Consumers Energy, responsible for managing compliance to all non-CIP NERC Standards for the TO, TP, TP, DP, and LSE functional entities, as well as shared responsibility for the BA functional entity. Mr. Rogers has been employed at Consumers Energy since 1978, and was a protective relay engineer from 1978 to 2002, with the exception of 3 years as the leader of the Instrumentation and Control design area. He led the ECAR investigation into the 2003 blackout, was the chairman of the ECAR Protection Panel and successor RF Protection Subcommittee from 2000 through 2012, led the NERC System Protection and Control Task Force from its inception in 2004 until its conversion into the System Protection and Control Subcommittee. He chaired the NERC Standard Drafting Teams for PRC-023 (all versions) and PRC-025, chaired the RF Standard Drafting Team related to the RF requirements related to PRC-002, and has led the NERC Standard Drafting Team since its formation in 2007.</p> <p>Mr. Roger received his Bachelor of Science in Electrical Engineering degree from Michigan Technological University in 1978, and is a registered PE in the State of Michigan. He is also a Senior Member of the Institute of Electrical and Electronic Engineers (IEEE), a member of the IEEE Power and Energy Society, and a member of the IEEE Standards Association. He was a member of the IEEE Working Group that developed IEEE 1547 and several associated standards, and is a member of IEEE Standard Coordinating Committee 21.</p>
John Anderson Principal Engineer	Xcel Energy, Inc.	(612) 630-4630 john.b.anderson@	John Anderson is responsible for the development and implementation of Xcel Energy's power plant

3353 Peachtree Road NE
Suite 600, North Tower
Atlanta, GA 30326
404-446-2560 | www.nerc.com

	1518 Chestnut Avenue N. 2nd Floor Minneapolis, Minnesota 55403	xcelenergy.com	electrical distribution system equipment maintenance programs including those for plant protective relay systems, power transformers, circuit breakers and battery systems. He has served in this capacity since 1998. Prior to taking on this fleet wide coordination role, he served for 8 years as an Electrical System Engineer at Xcel Energy's Monticello Nuclear Generating Station with responsibilities including coordination of the plant's protection system testing program. During this time, Mr. Anderson also earned a Senior Reactor Operator Certification for the plant. Prior to joining Northern State Power Company in 1990, Mr. Anderson completed the Navy Nuclear Propulsion Officer training program and served as a Nuclear Propulsion Plant Watch Officer and Electrical Distribution Officer aboard the USS ENTERPRISE (CVN-65). He holds a BSEE from the University of Minnesota.
Forrest Brock Station Services Superintendent	Western Farmers Electric Coop. 701 NE 7th Street PO Box 429 Anadarko, Oklahoma 73005-0429	405-247-4360 (405) 247-4453 Fx f_brock@wfec.com	Forrest Brock is the Superintendent of Station Services at Western Farmers Electric Cooperative – a generation and transmission cooperative serving 22 distribution cooperative members in Oklahoma and New Mexico. Mr. Brock has 25 years of protection and control experience earned through his service as a relay technician and supervisor, along with two years serving as Transmission Compliance Specialist prior to his promotion to department superintendent in 2012. Mr. Brock has been involved with the development of PRC-005-2 and its successor revisions since 2009. He is also a member of the Standard Drafting Team for Project 2007-06 System Protection Coordination developing NERC Reliability Standard PRC-027-1, and represents Cooperatives as a member of the NERC System Protection and Control Subcommittee (SPCS).
Aaron Feathers Principal Protection Engineer	Pacific Gas and Electric Company 487 West Shaw Avenue Fresno, California 93704	(559) 263-5011 Aaron.feathers@pg e.com	Aaron Feathers is a Principal Engineer in System Protection at Pacific Gas and Electric Company, where he has been employed since 1992. He has 23 years of experience in the application of protective relaying and control systems on transmission systems. Mr. Feather's current job responsibilities include design standards support, wide area RAS support, NERC PRC compliance support, and relay asset management support. He has a BSEE degree from California State Polytechnic University, San Luis Obispo and is a registered Professional Engineer in the State of California. He is also a member of IEEE and is on

			the Western Protective Relay Conference planning committee.
James M. Kinney Supervisor, Major Equipment	FirstEnergy Corp. 76 S. Main Street Akron, Ohio 44308	419-521-6252 330-777-6060 Fx kinneyj@ firstenergycorp.com	James M. Kinney is presently a Supervisor, Major Equipment, Transmission and Substation Services at FirstEnergy Corporation. Mr. Kinney has over 20 years of experience in the power industry including engineering, operations and maintenance. Since 2000, he has been responsible for substation commissioning as well as substation maintenance and testing programs at FirstEnergy Corporation. He is a senior member IEEE, a member of the IEEE Power and Energy Society, an individual member of the IEEE Standards Association, and also an individual member of Cigre'. He holds a BSEE from The Ohio State University and is a registered Professional Engineer in the State of Ohio.
Kristina Marriott Sr. Implementation Specialist	ENOSERV, A Division of Doble 7780 E. 106th Place Tulsa, Oklahoma 74133	(918) 960-4530 kmarriott@ enoserv.com	Kristina Marriott has been the Senior Implementation Specialist at ENOSERV for over 5 years and has worked for ENOSERV over 7. Her primary job consists of consulting & data application projects. Many of her projects have been geared to Transmission and Distribution, where she works with Engineering and Technical groups to develop, implement, and support maintenance Programs for Protection System components and other equipment utilizing multiple systems & applications. Prior to her current position, she supported multiple utilities in troubleshooting and maintaining Protective Relays. She has extensive knowledge and experience with asset management, business plans, policies, regulatory compliance, and continues to take an extreme interest in Protection and Control.
John E. Schechter	American Electric Power 700 Morrison Road 2nd Floor Gahanna, Ohio 43230	(614) 552-1908 jeschechter@ aep.com	John Schechter is with American Electric Power's Transmission Enabling Capital Excellence team in Columbus, Ohio. John has been with American Electric Power (AEP) or its operating companies since 1980. He has held many positions with increasing responsibility in substation operation, construction, maintenance or engineering spanning 35 years and has also held supervisory or managerial positions in distribution line design, distribution service dispatching, overhead and underground distribution maintenance and construction, transmission line asset management, and protection and control engineering. Following the 2003 blackout, John was named to the NERC Transmission Vegetation Management (VM) task force to draft the new vegetation management

			<p>standard. He was named to the NERC PRC-005-2 revision drafting team in 2011. John received the B.S.E.E. degree in electrical engineering from the University of Cincinnati, the M.S.E.E. degree in electric power systems engineering from The Ohio State University, and the M.B.A. degree from the University of Notre Dame. He is a registered professional engineer in the states of Indiana and Ohio. Mr. Schechter is a Senior Member of the Institute of Electrical and Electronics Engineers and its Power & Energy Society.</p>
<p>William D. Shultz Engineering Manager</p>	<p>Southern Company Generation 42 Inverness Center Parkway Mail Bin B425 Birmingham, AL 35242</p>	<p>(205) 992-5526 (205) 992-5103 Fx wdshultz@ southernco.com</p>	<p>Bill Shultz currently provides oversight and support for Southern Company Generation's NERC compliance program for Generator Owner and Generator Operator requirements. His work with Southern Company has included 32 years of experience in electric power generating plant electrical field services covering new equipment installation, testing, startup, troubleshooting, and maintenance of motors, electrical controls, switchgear, circuit breakers, generators, and transformers. This work also included 10 years of experience with the application of protective relaying to electric power generating stations. He is experienced in emergency power generating plant project management and remote control of distributed generation systems and with instrumentation, control, and power circuitry.</p> <p>Mr. Shultz received his Bachelor of Science in Electrical Engineering from the University of Tennessee and Masters of Science in Electrical Engineering from Auburn University. He is a registered Professional Engineer in the state of Alabama.</p>
<p>Eric Udren Executive Advisor</p>	<p>Quanta Technology 1395 Terrace Drive Pittsburgh, Pennsylvania 15228- 1636</p>	<p>(919) 334-3070 eudren@ quanta- technology.com</p>	<p>Eric A. Udren has a 43 year distinguished career in design and application of protective relaying, utility substation control, and communications systems. Mr. Udren developed protection software for the world's first computer based transmission line relaying system, as well as for the world's first substation P&C system based on local area network communications. He has worked with major utilities to develop new substation protection, control, data communications, SPS, and wide area monitoring and protection system designs, including major projects for substation integration based on IEC 61850. Mr. Udren currently serves as Executive Advisor with Quanta Technology, LLC of Raleigh, NC with his office in Pittsburgh, PA. Mr. Udren is</p>

			IEEE Fellow, Chair of the Relaying Communications Subcommittee of the IEEE Power System Relaying Committee (PSRC) and chairs two standards working groups of PSRC. He is Technical Advisor to the US National Committee of IEC for protective relay standards from TC 95; and is member of the IEC TC 57 WG 10 that develops IEC 61850 power systems communications and integration protocol. Eric serves on the NERC System Protection and Control Subcommittee (SPCS), as well as the subject PRC-005-2 Drafting Team. He has written and presented over 90 technical papers and book chapters.
Scott Vaughan Senior Grid Assets Engineer	California ISO CAISO Roseville, California 95678	(916) 351-4428 svaughan@ caiso.com	Scott Vaughan is currently a Lead Grid Assets Engineer at the California Independent System Operator (CAISO). He has over 20 years of industry experience. In his current position, Mr. Vaughan is responsible for overseeing and leading the implementation and enforcement of the CAISO Transmission Maintenance Standards, conducting reviews of each Participating Transmission Owner's maintenance records and facilities and analyzing the results from annual maintenance reviews, standard maintenance reporting data, and availability measures to identify any positive or negative trending. Throughout his career, he has held positions as a protection, generation facility design, and substation design engineer. Mr. Vaughan holds a BSEE from the California Polytechnical State University at San Luis Obispo, a MBA from Golden Gate University and is a registered engineer in the State of California.
Matthew Westrich Assistant Manager Asset Maintenance	American Transmission Company, LLC 1075 Woodward Avenue Kingsford, Michigan 49802	(906) 779-7901 mwestrich@ atllc.com	Mathew Westrich is presently the Assistant Manager Asset Maintenance for American Transmission Company. Previously Matt held positions as Substation Maintenance Engineer and Asset Manager with ATC. He also worked for Wisconsin Energies as a relay testing technician since 1982. He has over 30 years' experience in Protection, Commissioning and Maintenance. He is a licensed P.E. with the State of Wisconsin.
Philip B. Winston Chief Engineer, Protection and Control	Southern Company 62 Like Mirror Road, Bin # 50061 Forest Park, Georgia 30297	(404) 608-5989 (404) 608-5199 Fx pbwinsto@ southernco.com	Philip B. Winston is presently the Chief Engineer, Protection and Control Applications for Southern Company Transmission. Previously Mr. Winston was the Manager, Protection and Control Applications with Georgia Power Company. With over 43 years' experience in Protection, Operations, Engineering, and Maintenance, he has been active

			<p>in Southern Company standardization efforts as well as being involved in regional and national organizations responsible for utility standards and disturbance analysis. He is a past Chairman of the IEEE/Power System Relaying Committee, a past Chair of the PSRC Systems Protection and the Line Protection Subcommittees, past Standards Coordinator for IEEE PSRC and serves on the IEEE Standards Association Standards Board, NesCom (chair), and ProCom. He is the Chair of the NERC SPCS, and serves on several NERC Standard Drafting Teams. He holds a BSEE from Clemson University, a MSEE from Georgia Tech, and is a registered Professional Engineer in the State of Georgia.</p>
<p>Stephen Crutchfield Senior Standards Developer</p>	<p>North American Electric Reliability Corporation 3353 Peachtree Road, NE, Suite 600 - North Tower Atlanta, GA 30326</p>	<p>(609) 651-9455 Stephen.crutchfield @nerc.net</p>	<p>Stephen Crutchfield is the lead NERC Staff Coordinator for Project 2007-17.4, PRC-005 Order No. 803 Directive. Stephen began his career with NERC in May 2007. Prior to joining NERC, Stephen was a Project Manager with Shaw Energy Delivery Services, managing engineering and construction projects in the substation and transmission line fields. Stephen's background also includes experience with PJM as Manager of RTO Integration, working on the operations and markets integration of new members (AEP, ComEd, Dayton, Dominion and Duquesne) into PJM and southern seams operations issues with Progress Energy, Duke and TVA. He also helped lead the team that was developing GridSouth in the dual roles of Organization Architect and Manager of Customer Support. Prior to GridSouth, Mr. Crutchfield was the Manager of Power System Operations Training at Progress Energy where he spent over 10 years training System Operators and Engineers. Overall, Stephen was with Progress Energy for 16 years.</p> <p>Mr. Crutchfield received his Bachelor of Arts in Physics from the University of Virginia and Masters of Science in Electrical Engineering from North Carolina State University. He holds a Master of Science in Management degree, also from North Carolina State University. He is also a member of the Institute of Electrical and Electronic Engineers and the Power and Energy Society.</p>
<p>Jordan Mallory Standards Developer</p>	<p>North American Electric Reliability Corporation</p>	<p>(404) 446-XXXX jordan.mallory@ nerc.net</p>	<p>Jordan Mallory is currently a standards developer for the FAC-003-4 Vegetation Management project and is back-up to Project 2007-17.4, PRC-005 Order No. 803 Directive. She was the standards developer over PER-005-2 and PRC-005-4 projects. Ms.</p>

	3353 Peachtree Road, NE, Suite 600 - North Tower Atlanta, GA 30326		Mallory began her career at NERC in June 2011. Prior, Jordan worked at MEAG Power as a Senior Administrative Assistant. She received her Business Degree in Managerial Science from Georgia State University.
Sean Cavote Manager of Standards Development	North American Electric Reliability Corporation 3353 Peachtree Road NE, Suite 600 – North Tower Atlanta, GA 30326	404.446.9697 (O) sean.cavote@nerc.net	Sean Cavote currently serves as Manager of Standards Development. Sean joined the North American Electric Reliability Corporation (NERC) on January 28, 2013. Mr. Cavote was with NiSource in Indianapolis, Indiana where he was a senior FERC attorney. His prior experience was with Van Ness Feldman in Washington, D.C. as an associate energy attorney, and with United Dynamics in Louisville, Kentucky as a power generation consultant. He graduated from the University of Louisville with a BA in Political Science and later earned a Juris Doctor from the George Washington University Law School.