

# Relay Loadability Exceptions

## Determination and Application of Practical Relaying Loadability Ratings

*Version 1.1*

*November 2004*



Prepared by the  
System Protection and Control Task Force  
of the  
North American Electric Reliability Council

Copyright © 2004 by North American Electric Reliability Council. All rights reserved.

A New Jersey Nonprofit Corporation



## Table of Contents

<b>INTRODUCTION</b>	<b>1</b>
NERC RECOMMENDATION 8A	2
CLARIFICATIONS	2
US – CANADA TASK FORCE RECOMMENDATION 21, PART A	3
APPLICABILITY OF NERC LOADABILITY PARAMETERS	3
CAUTIONS	4
<b>EXCEPTIONS</b>	<b>5</b>
TEMPORARY EXCEPTIONS	5
TECHNICAL EXCEPTIONS	5
EXCEPTION 1 — UTILIZE THE 15-MINUTE RATING OF THE TRANSMISSION LINE	6
EXCEPTION 2 — MAXIMUM POWER TRANSFER LIMIT ACROSS A TRANSMISSION LINE	7
EXCEPTION 3 — MAXIMUM POWER TRANSFER LIMIT ACROSS A TRANSMISSION LINE BASED ON THE BREAKER INTERRUPTING RATINGS AT EACH END OF THE LINE	9
EXCEPTION 4 — SYSTEM’S SITE-SPECIFIC CALCULATED MAXIMUM POWER TRANSFER LIMIT	12
EXCEPTION 5 — SPECIAL CONSIDERATIONS FOR SERIES-COMPENSATED LINES	14
EXCEPTION 6 — WEAK SOURCE SYSTEMS	16
EXCEPTION 7 — LONG LINE RELAY LOADABILITY	17
EXCEPTION 8 — THREE (OR MORE) TERMINAL LINES AND LINES WITH ONE OR MORE RADIAL TAPS	20
EXCEPTION 9 — GENERATION REMOTE TO LOAD	23
EXCEPTION 10 — LOAD REMOTE TO GENERATION	25
EXCEPTION 11 — REMOTE COHESIVE LOAD CENTER	26
EXCEPTION 12 — COHESIVE LOAD CENTER REMOTE TO TRANSMISSION SYSTEM	27
<b>APPENDICES</b>	<b>I</b>
LONG LINE MAXIMUM POWER TRANSFER EQUATIONS	II
RELATED READING AND REFERENCES	IV
SYSTEM PROTECTION AND CONTROL TASK FORCE	V

---

The NERC Planning Committee approved this Document on November 9, 2004, subject to review by the Planning Committee Executive Committee; that body unanimously approved the document on November 18, 2004.



## INTRODUCTION

The intent of Recommendation 8A is to ensure that transmission facilities are not unnecessarily interrupted during system disturbances when operator action within the first 15-minutes could alleviate potentially damaging overloads or prevent cascading outages. The four-hour winter thermal current ratings of the line, multiplied by 1.5 at 0.85 per unit voltage at a line phase angle of 30 degrees, was used in Footnote 6 of Recommendation 8A of the *August 14, 2003 Blackout: NERC Actions to Prevent and Mitigate the Impacts of Future Cascading Blackouts*, approved by the NERC Board of Trustees on February 10, 2004, and the subsequent SPCTF clarification (issued on June 22, 2004) as the basis to establish a general thermal loadability requirement. In many cases, this is a legitimate loadability requirement. In some cases, detailed studies have been performed to more accurately identify the 15-minute rating of a transmission line. In other cases, other factors limit the loadability of transmission lines to less than that established in Footnote 6 of recommendation 8A. For these reasons, the SPCTF has developed several classifications of technical exceptions to the loading parameters as stated in Footnote 6 of recommendation 8A. Exceptions based on system parameters require an annual review<sup>1</sup> or when system topography and parameters change. **Where practical, the transmission system protection owners (TPSOs) are strongly encouraged to meet the loadability parameters without petitioning for exceptions.**

While Recommendation 8A focuses on the loadability requirements to ensure that protection systems do not contribute to cascading or blackouts, it is imperative that the TPSOs reliably protect the electrical network for all fault conditions. This balance between adequate loadability and adequate equipment protection may necessitate various mitigation methods including:

1. Elimination of unnecessary protection functions (beyond applicable protection needs)
2. Adjusting the maximum torque angle on the relay
3. Installing relays that can tolerate load currents while still reliably tripping for fault conditions
4. Applying direct transfer tripping to provide for remote backup functions
5. Installing additional circuit breakers to reduce the required relay reach, particularly on lines with more than two terminals

Every effort should be made to mitigate non-conforming critical lines on a priority basis.

Assuming all these mitigation methods have been considered, the loadability of the power lines should not reduce the ability to reliably detect faults and issue appropriate trip signals.

If there is relaying application for which the TPSO feels that inhibiting relay tripping on load will compromise reliable fault clearing using the best-in-class protection practices, then the TPSO shall provide sufficient justification for their proposed exception.

---

<sup>1</sup> Loadability exceptions based on system parameters must be reevaluated as system parameters change. This review and verification of exception parameters should be performed annually by the TPSO, evaluated by the Regional Reliability Organization, and reported on to NERC.

## NERC Recommendation 8A

From the report *August 14, 2003 Blackout: NERC Actions to Prevent and Mitigate the Impacts of Future Cascading Blackouts*, approved by the NERC Board of Trustees on February 10, 2004:

### **NERC Recommendation 8, part A:**

All transmission owners shall, no later than September 30, 2004, evaluate the zone 3 relay settings on all transmission lines operating at 230 kV and above for the purpose of verifying that each zone 3 relay is not set to trip on load under extreme emergency conditions.<sup>6</sup> In each case that a zone 3 relay is set so as to trip on load under extreme conditions, the transmission operator shall reset, upgrade, replace, or otherwise mitigate the overreach of those relays as soon as possible and on a priority basis, but no later than December 31, 2005. Upon completing analysis of its application of zone 3 relays, each transmission owner may no later than December 31, 2004 submit justification to NERC for applying zone 3 relays outside of these recommended parameters. The Planning Committee shall review such exceptions to ensure they do not increase the risk of widening a cascading failure of the power system.

---

<sup>6</sup> The NERC investigation team recommends that the zone 3 relay, if used, should not operate at or below 150% of the emergency ampere rating of a line, assuming a .85 per unit voltage and a line phase angle of 30 degrees.

## Clarifications

The definition of “emergency ampere rating” of a circuit in Footnote 6 of Recommendation 8A is defined as:

The NERC Planning Committee approved the following clarification of the definition of emergency ampere rating for application of Recommendation 8A on June 18, 2004:

**Emergency Ampere Rating** — “The highest seasonal ampere circuit rating (that most closely approximates a 4-hour rating) that must be accommodated by relay settings to prevent incursion.” That rating will typically be the winter short-term (four-hour) emergency rating of the line and series elements. The line rating should be determined by the lowest ampere rated device in the line (conductor, airswitch, breaker, wavetrap, series transformer, series capacitors, reactors, etc) or by the sag design limit of the transmission line for the selected conditions. The evaluation of all Zone 3 relays should use whatever ampere rating currently used that most closely approximates a 4-hour rating.

**Series Compensation Consideration** — Since series capacitors can be bypassed, they cannot be considered the current limited element of a circuit in the definition of Emergency Ampere Rating above. Exception 5, *Special Considerations for Series Compensated Lines*, is specifically for series compensated lines.

**Zone 3 Definition** — The term Zone 3 relay should be defined as “any distance relay (forward or reverse) acting as remote backup (as defined in IEEE Standard C37.113, excerpted below), regardless of the nomenclature used or any relay that is intentionally set to protect facilities beyond the protected line.”

**IEEE Guide for Protective Relaying – Standard C37.113****Section 5.3.7.1 – Remote Backup**

“This form of protection relies on the remote relaying on adjacent circuits to overreach the primary zones of protection. Tripping is delayed to allow for the primary protection to operate. The effects of infeed from adjacent lines must be taken into account to ensure complete coverage. In some cases, if the remote backup relays cannot completely cover the protected zone under normal conditions, they must at least be able to operate sequentially. Obviously, this leads to lengthy delays in the clearing of faults. A serious drawback of remote backup protection is the complete loss of supply to the affected substations, because all lines into the station have to be opened to remotely clear the fault.”

**US – Canada Task Force Recommendation 21, Part A**

In the *US – Canada Power System Outage Task Force Final Report on the August 14, 2003 Blackout in the United States and Canada: Causes and Recommendations*, issued in April 2004:

**US – Canada Recommendation 21, Part A**

“Make more effective and wider use of system protection measures.”

“In its requirements of February 10, 2004, NERC:

Directed all transmission owners to evaluate the settings of zone 3 relays on all transmission lines of 230 kV and higher.”

“Task Force:

Recommends that NERC broaden the review to include operationally significant 115 kV and 138 kV lines, e.g., lines that are part of monitored flowgates or interfaces. Transmission owners should also look for zone 2 relays set to operate like zone 3s.”

**Applicability of NERC Loadability Parameters**

NERC Recommendation 8A specifies applicability to Zone 3 relays, on lines 230 kV and above. The United States – Canada Recommendation 21, Part A extends this to “operationally significant” lines of lower voltages (115 kV and 138 kV).

However, philosophically, no *circuit* (including power transformers) should trip undesirably for expected and potential non-fault loading conditions. Such conditions include normal and emergency loading conditions, and stable transient swings on the power system during system disturbances.

**Therefore, the NERC Relay Loadability Parameters expressed in Recommendation 8A should apply to:**

- All circuits 230 kV and above
- All critical circuits (as determined by the transmission owner's Reliability Council through regional, multi-regional, or reliability coordination studies) 115 kV and above.
- Any relays on lines, transformers, and series-reactors that may undesirably trip for expected and potential non-fault loading conditions, including:
  - All distance relays that can trip directly or as part of a pilot tripping scheme
  - All types of phase-overcurrent relays

***In all cases, adherence to the NERC Loadability Parameters shall not relieve the TPSOs of the responsibility to adequately protect the bulk transmission system.***

## **Cautions**

1. Although out-of-step blocking elements are sometimes applied to protect for system swing conditions, application of out-of-step blocking elements cannot be used to ensure meeting loadability requirements.
2. Derating of transmission circuits solely for the purpose of conforming to NERC Recommendation 8A should not be done without the recognition of the impacts to system transfer limits.
3. All circuit rating changes must be coordinated with the TPSO's Reliability Coordinator and neighboring systems.
4. Exceptions granted under some situations must be reviewed annually, or whenever significant changes are made to the circuit or the surrounding system. Where this is necessary, it is noted in the exception description.

***In all cases, adherence to the NERC Loadability Parameters shall not relieve the TPSOs of the responsibility to adequately protect the bulk transmission system.***



## EXCEPTIONS

TPSOs may apply for two types of exceptions: temporary and technical. Any petition for temporary exceptions shall include all necessary supporting documentation to help the Regions and the SPCTF review the requested exception. Petitions for technical exceptions shall be submitted on the appropriate Technical Exception Template. Any technical exception beyond those contained in this document will require substantial supporting documentation to be submitted with the exception request.

### Temporary Exceptions

Temporary Exceptions allow for a delayed implementation schedule for facilities that require modification due to the inability to complete the work within the prescribed time frame because of facility clearance (equipment maintenance outages) or work force issues. Temporary exceptions may also be granted for application of temporary mitigation plans until full implementation can be achieved.

***All applications for temporary exceptions should include sufficient justification for the delay in mitigation as well as a mitigation plan with a planned schedule for completion.***

For those facilities that are substantially outside the Recommendation 8A loadability requirements, the TPSO should have done everything practical with existing equipment to mitigate non-conforming relays and maximizing loadability before applying for temporary exceptions.

Such mitigation includes but is not limited to:

1. Elimination of unnecessary protection functions (beyond applicable protection needs)
2. Adjusting the maximum torque angle on the relay
3. Resetting of relays as possible while still meeting established protection practices

Every effort should be made to mitigate non-conforming critical lines as soon as possible on a priority basis.

### Technical Exceptions

Technical Exceptions would be justified on technical merit where facilities could not, under any reasonable contingency, be loaded to a level that would initiate a protective relay operation, under current system conditions. Technical exceptions would be subject to review in light of future system changes.

If Technical Exceptions to the loadability requirement are required, the TPSO is encouraged to use one of the exception groups in this document. If none of those exception groups are applicable to the TPSO's situation, then specific exception details can be submitted, with regional concurrence, to the SPCTF for evaluation and approval. Complete documentation should be supplied with the exception request to allow the SPCTF to perform a timely and thorough review of the request.

The following are a number of potential technical exemptions that can be requested.

## Exception 1 — Utilize the 15-Minute Rating of the Transmission Line

When the original loadability parameters were established, it was based on the 4-hour emergency rating. The intent of the 150% factor applied to the emergency ampere rating in the loadability requirement was to approximate the 15-minute rating of the transmission line and add some additional margin. Although the original study performed to establish the 150% factor did not segregate the portion of the 150% factor that was to approximate the 15-minute capability from that portion that was to be a safety margin, it has been determined that a 115% safety margin is an appropriate margin. In situations where detailed studies have been performed to establish 15-minute ratings on a transmission line, the 15-minute rating can be used to establish the loadability requirement for the protective relays.

In the case that the 15-minute rating has been established, the loadability requirement is:

The tripping relay should not operate at or below 1.15 times the 15-minute winter emergency ampere rating ( $I_{emergency}$ ) of the line. When evaluating a distance relay, assume a 0.85 per unit relay voltage and a line phase (power factor) angle of 30 degrees.

$$\text{Example: } Z_{relay30} = \frac{0.85 \times V_{L-L}}{\sqrt{3} \times 1.15 \times I_{total}}$$

Transmission operators are instructed to take immediate remedial steps, including dropping load, if the current on the circuit reaches  $I_{emergency}$ .

## Exception 2 — Maximum Power Transfer Limit Across a Transmission Line

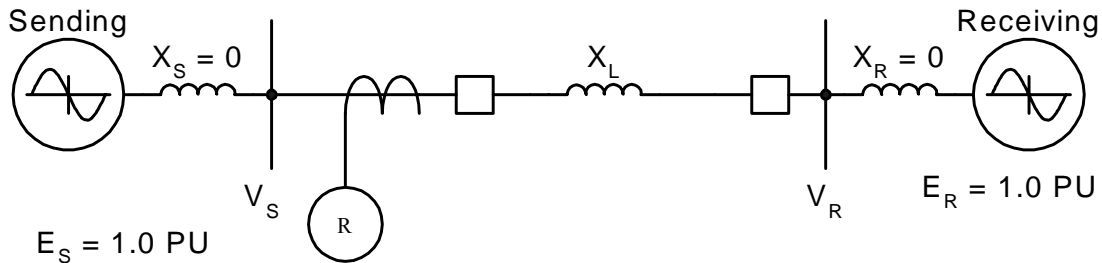

**Figure 2 – Maximum Power Transfer**

The power transfer across a transmission line (*Figure 2*) is defined by the equation<sup>2</sup>:

$$P = \frac{V_S \times V_R \times \sin \delta}{X_L}$$

Where:  $P$  = the power flow across the transmission line

$V_S$  = Phase-to-phase voltage at the sending bus

$V_R$  = Phase-to-phase voltage at the receiving bus

$\delta$  = Voltage angle between  $V_S$  and  $V_R$

$X_L$  = Reactance of the transmission line in ohms

The theoretical maximum power transfer occurs when  $\delta$  is 90 degrees. The real maximum power transfer will be less than the theoretical maximum power transfer and will occur at some angle less than 90 degrees since the source impedance of the system is not zero. For purposes of this exception, a number of conservative assumptions are made:

- $\delta$  is set at 90 degrees
- Voltage at each bus is set at 1.0 per unit
- An infinite source is assumed behind each bus; i.e. no source impedance is assumed.

No additional margin is applied in this exception because the above factors establish an inherent margin.

The equation for maximum power becomes:

$$P_{\max} = \frac{V^2}{X_L}$$

$$I_{\text{real}} = \frac{P_{\max}}{\sqrt{3} \times V}$$

<sup>2</sup> More explicit equations that may be beneficial for long transmission lines (typically 80 miles or more) are contained in Appendix A.

$$I_{real} = \frac{V}{\sqrt{3} \times X_L}$$

Where:

$I_{real}$  = Real component of current

$V$  = Nominal phase-to-phase bus voltage

At maximum power transfer, the real component of current and the reactive component of current are equal; therefore:

$$I_{total} = \sqrt{2} \times I_{real}$$

$$I_{total} = \frac{\sqrt{2} \times V}{\sqrt{3} \times X_L}$$

$$I_{total} = \frac{0.816 \times V}{X_L}$$

Where:

$I_{total}$  is the total current at maximum power transfer.

For this exception:

The tripping relay should not operate at or below  $I_{total}$  (where  $I_{total} = \frac{0.816 \times V}{X_L}$ ). When evaluating a distance relay, assume a 0.85 per unit relay voltage and a line phase (power factor) angle of 30 degrees.

Example:  $Z_{relay30} = \frac{0.85 \times V_{L-L}}{\sqrt{3} \times 1.15 \times I_{total}}$

## Exception 3 — Maximum Power Transfer Limit Across a Transmission Line Based on the Breaker Interrupting Ratings at Each End of the Line

The power transfer across the system shown in *Figure 3* is defined by the equation<sup>3</sup>: The source impedance for each terminal connected to the line is determined and the sending and receiving voltages set at 1.05 per unit.

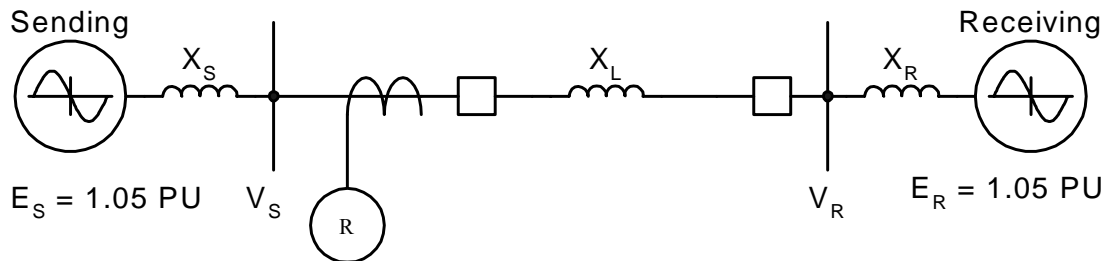

**Figure 3– Maximum Power Transfer Based on Breaker Interrupting Ratings**

$$P = \frac{(E_S \times E_R \times \sin \delta)}{(X_S + X_R + X_L)}$$

Where:

- $P$  = Power flow across the transmission line
- $P_{max}$  = Maximum power that can be transferred across a system
- $E_S$  = Thévenin phase-to-phase voltage at the system sending bus
- $E_R$  = Thévenin phase-to-phase voltage at the system receiving bus
- $\delta$  = Voltage angle between  $E_S$  and  $E_R$
- $X_S$  = Calculated reactance in ohms of the sending bus (based on breaker interrupting duty)
- $X_R$  = Calculated reactance in ohms of the receiving bus (based on breaker interrupting duty)
- $X_L$  = Reactance of the transmission line in ohms

The theoretical maximum power transfer occurs when  $\delta$  is 90 degrees. All stable maximum power transfers will be less than the theoretical maximum power transfer and will occur at some angle less than 90 degrees since the source impedance of the system is not zero. For purposes of this exception, a number of conservative assumptions are made:

- $\delta$  is set at 90 degrees
- Voltage at each bus is set at 1.05 per unit
- The actual source impedance is typically greater than the source impedance calculated based on the actual breaker ratings.

<sup>3</sup> More explicit equations that may be beneficial for long transmission lines (typically 80 miles or more) are contained in Appendix A.

No additional margin is applied in this exception because the above factors establish an inherent margin.

For this exception, the source impedance that would limit the three-phase fault current on the line-side breaker bushing terminals is calculated based on the interrupting rating of the breaker.

$$X_S = \frac{V}{\sqrt{3} \times I_{BRS}} = \frac{0.577 \times V}{I_{BRS}}$$

$$X_R = \frac{V}{\sqrt{3} \times I_{BRR}} = \frac{0.577 \times V}{I_{BRR}}$$

Where:

$V$  = Nominal phase-to-phase system voltage

$I_{BRS}$  = Interrupting rating of the breaker in amps on the sending bus

$I_{BRR}$  = Interrupting rating of the breaker in amps on the receiving bus

The maximum power transfer across the system occurs when  $\delta$  is 90 degrees across a system. Therefore, the maximum power transfer equation becomes:

$$P_{\max} = \frac{1.05 \times V \times 1.05 \times V \times \sin \delta}{(X_S + X_R + X_L)}$$

$$I_{real} = \frac{P_{\max}}{\sqrt{3} \times 1.05 \times V}$$

$$I_{real} = \frac{1.05 \times V}{\sqrt{3} \times (X_S + X_R + X_L)}$$

$$I_{real} = \frac{0.606 \times V}{(X_S + X_R + X_L)}$$

Where:

$I_{real}$  = Real component of current

Substituting for  $X_S$  and  $X_R$ :

$$I_{real} = \frac{0.606 \times V}{\left[ \frac{0.577 \times V}{I_{BRS}} + \frac{0.577 \times V}{I_{BRR}} + X_L \right]}$$

At maximum power transfer, the real component of current and the reactive component of current are equal; therefore:

$$I_{total} = \sqrt{2} \times I_{real}$$

$$I_{total} = \frac{1.414 \times 0.606 \times V}{\left[ \frac{0.577 \times V}{I_{BRS}} + \frac{0.577 \times V}{I_{BRR}} + X_L \right]}$$

$$I_{total} = \frac{0.857 \times V}{\left[ \frac{0.577 \times V}{I_{BRS}} + \frac{0.577 \times V}{I_{BRR}} + X_L \right]}$$

Where:

$I_{total}$  = Total current at maximum power transfer

The tripping relay should not operate at or below  $I_{total}$ . When evaluating a distance relay, assume a 0.85 per unit relay voltage and a line phase (power factor) angle of 30 degrees.

Example:  $Z_{relay30} = \frac{0.85 \times V_{L-L}}{\sqrt{3} \times I_{total}}$

This exception is valid as long as the breakers are not overdutied or replaced.

## Exception 4 — System's Site-Specific Calculated Maximum Power Transfer Limit

For this exception, actual source and receiving end impedances are determined using a short circuit program and choosing the classical or flat start option to calculate the fault parameters. The impedances required for this calculation are the generator subtransient impedances (*Figure 4*).

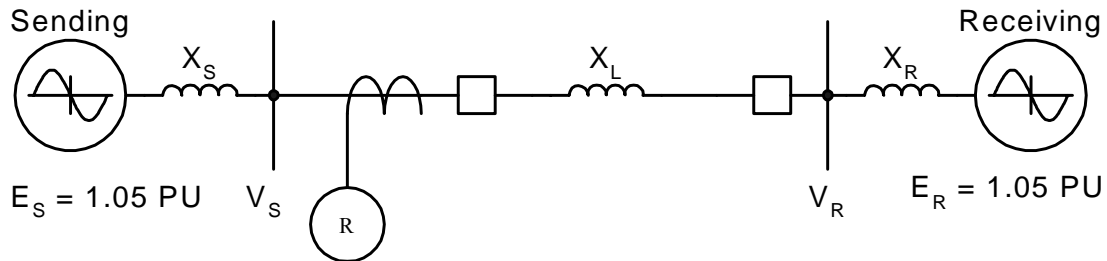

**Figure 4 – Site-Specific Maximum Power Transfer Limit**

The recommended procedure for determining  $X_S$  and  $X_R$  is:

- Remove the line or lines under study (parallel lines need to be removed prior to doing the fault study)
- Apply a three-phase short circuit to the sending and receiving end buses.
- The program will calculate a number of fault parameters including the equivalent Thévenin source impedances.
- The real component of the Thévenin impedance is ignored.

The voltage angle across the system is set to 90 degrees, and the current magnitude ( $I_{max}$ ) for the maximum power transfer across the system is determined as follows<sup>4</sup>:

$$P_{max} = \frac{(1.05 \times V)^2}{(X_S + X_R + X_L)}$$

Where:

- $P_{max}$  = Maximum power that can be transferred across a system
- $E_S$  = Thévenin phase-to-phase voltage at the system sending bus
- $E_R$  = Thévenin phase-to-phase voltage at the system receiving bus
- $\delta$  = Voltage angle between  $E_S$  and  $E_R$
- $X_S$  = Thévenin equivalent reactance in ohms of the sending bus
- $X_R$  = Thévenin equivalent reactance in ohms of the receiving bus
- $X_L$  = Reactance of the transmission line in ohms

<sup>4</sup> More explicit equations that may be beneficial for long transmission lines (typically 80 miles or more) are contained in Appendix A.



$V$  = Nominal phase-to-phase system voltage

$$I_{real} = \frac{1.05 \times V}{\sqrt{3}(X_S + X_R + X_L)}$$

$$I_{real} = \frac{0.606 \times V}{(X_S + X_R + X_L)}$$

The theoretical maximum power transfer occurs when  $\delta$  is 90 degrees. All stable maximum power transfers will be less than the theoretical maximum power transfer and will occur at some angle less than 90 degrees since the source impedance of the system is not zero. For purposes of this exception, a number of conservative assumptions are made:

- $\delta$  is set at 90 degrees
- Voltage at each bus is set at 1.05 per unit
- The source impedances are calculated using the sub-transient generator reactances.

No additional margin is applied in this exception because the above factors establish an inherent margin.

At maximum power transfer, the real component of current and the reactive component of current are equal; therefore:

$$I_{total} = \sqrt{2} \times I_{real}$$

$$I_{total} = \frac{\sqrt{2} \times 0.606 \times V}{(X_S + X_R + X_L)}$$

$$I_{total} = \frac{0.857 \times V}{(X_S + X_R + X_L)}$$

Where:

$I_{total}$  = Total current at maximum power transfer

For this exception:

The tripping relay should not operate at or below a calculated  $I_{total}$ . When evaluating a distance relay, assume a 0.85 per unit relay voltage and a line phase (power factor) angle of 30 degrees.

Example:  $Z_{relay30} = \frac{0.85 \times V_{L-L}}{\sqrt{3} \times I_{total}}$

This exception must be re-verified annually or whenever major system changes are made.

## Exception 5 — Special Considerations for Series-Compensated Lines

Series capacitors are used on long transmission lines to allow increased power transfer. Special consideration must be made in computing the maximum power flow that protective relays must accommodate on series compensated transmission lines. Capacitor cans have a short-term over voltage capability that is defined in IEEE standard 1036. This allows series capacitors to carry currents in excess of their nominal rating for a short term. Series capacitor emergency ratings, typically 30-minute, are frequently specified during design.

The capacitor banks are protected from overload conditions by spark gaps and/or metal oxide varistors (MOVs) and can be also be protected /bypassed by breakers. Protective gaps and MOVs (*Figure 5*) operate on the voltage across the capacitor ( $V_{protective}$ ).

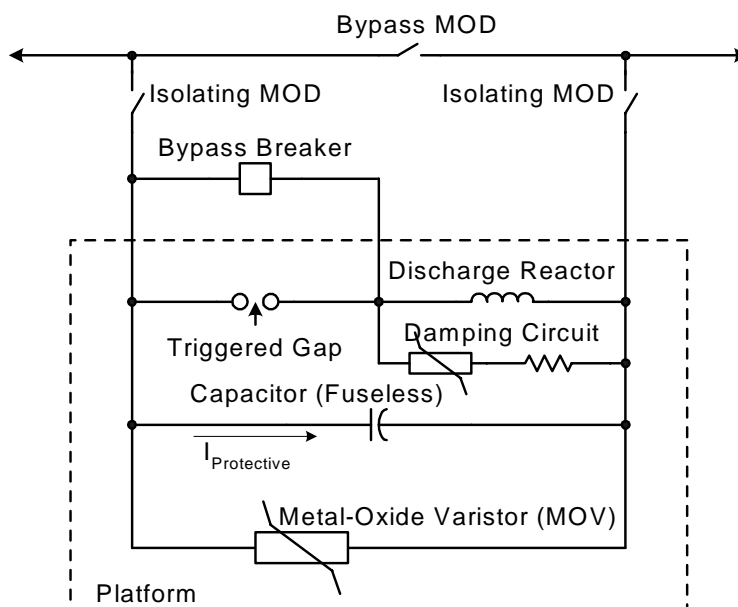

**Figure 5 – Series Capacitor Components**

This voltage can be converted to a current by the equation:

$$I_{protective} = \frac{V_{protective}}{X_C}$$

Where:

$V_{protective}$  = Protective level of voltage across the capacitor spark gaps and/or MOVs

$X_C$  = Capacitive reactance

The capacitor protection limits the theoretical maximum power flow because  $I_{total}$ , assuming the line inductive reactance is reduced by the capacitive reactance, will typically exceed  $I_{protective}$ . A current of  $I_{protective}$  or greater will result in a capacitor bypass. This reduces the theoretical maximum power transfer to that of only the line inductive reactance as described in Exception 2.

The relay settings must be evaluated against 115% of the highest series capacitor emergency current rating and the maximum power transfer calculated in Exceptions 2, 3 or 4 using the full line inductive

reactance (uncompensated line reactance). This must be done to accommodate situations where the capacitor is bypassed for reasons other than  $I_{protective}$ . The relay must be set to accommodate the greater of these two currents.

The tripping relay should not operate at or below the greater of:

1. 1.15 times the highest emergency rating of the series capacitor. When evaluating a distance relay, assume a 0.85 per unit relay voltage and a line phase (power factor) angle of 30 degrees.
2.  $I_{total}$  (where  $I_{total}$  is calculated under Exception 2, 3, or 4 using the full line inductive reactance). When evaluating a distance relay, assume a 0.85 per unit relay voltage and a line phase (power factor) angle of 30 degrees.

Example: 
$$Z_{relay30} = \frac{0.85 \times V_{L-L}}{\sqrt{3} \times 1.15 \times I_{total}}$$

## Exception 6 — Weak Source Systems

In some cases, the maximum line end three-phase fault current is small relative to the thermal loadability of the conductor. Such cases exist due to some combination of weak sources, long lines, and the topology of the transmission system (*Figure 6*).

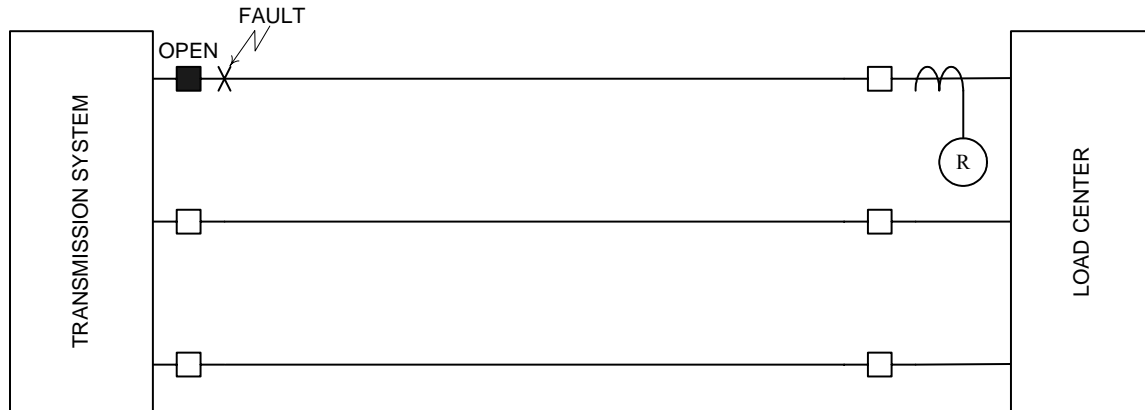

**Figure 6 – Weak Source Systems**

Since the line end fault is the maximum current at one per unit phase to ground voltage and it is possible to have a voltage of 90 degrees across the line for maximum power transfer across the line, the voltage across the line is equal to:

$$V_{S-R} = \sqrt{V_S^2 + V_R^2} = \sqrt{2} \times V_{LN}$$

It is necessary to increase the line end fault current  $I_{fault}$  by  $\sqrt{2}$  to reflect the maximum current that the terminal could see for maximum power transfer.

$$I_{max} = \sqrt{2} \times 1.05 \times I_{fault}$$

$$I_{max} = 1.485 \times I_{fault}$$

Where:

$I_{fault}$  is the line-end three-phase fault current magnitude obtained from a short circuit study, reflecting sub-transient generator reactances.

For this exception:

The tripping relay should not operate at or below 1.15 times  $I_{max}$ , where  $I_{max}$  is the maximum end of line three-phase fault current magnitude. When evaluating a distance relay, assume a 0.85 per unit relay voltage and a line phase (power factor) angle of 30 degrees.

$$\text{Example: } Z_{relay30} = \frac{0.85 \times V_{L-L}}{\sqrt{3} \times 1.15 \times I_{total}}$$

## Exception 7 — Long Line Relay Loadability

This exception applies only to classical two-terminal circuits. For lines with other configurations, see the exception for *Three (or more) Terminal Lines and Lines with One or More Radial Taps* (Exception 8). A large number of transmission lines in North America are protected with distance based relays that use a mho characteristic. Although other relay characteristics are now available that offer the same fault protection with more immunity to load encroachment, generally they are not required based on the following:

1. The original loadability concern from the Northeast blackout (and other blackouts) was overly sensitive distance relays (usually Zone 3 relays).
2. Distance relays with mho characteristics that are set at 125% of the line length are clearly not “overly sensitive,” and were not responsible for any of the documented cascading outages, under steady-state conditions.
3. It is unlikely that distance relays with mho characteristics set at 125% of line length will misoperate due to recoverable loading during major events.
4. Even though unintentional relay operation due to load could clearly be mitigated with blinders or other load encroachment techniques, in the vast majority of cases, it may not be necessary.

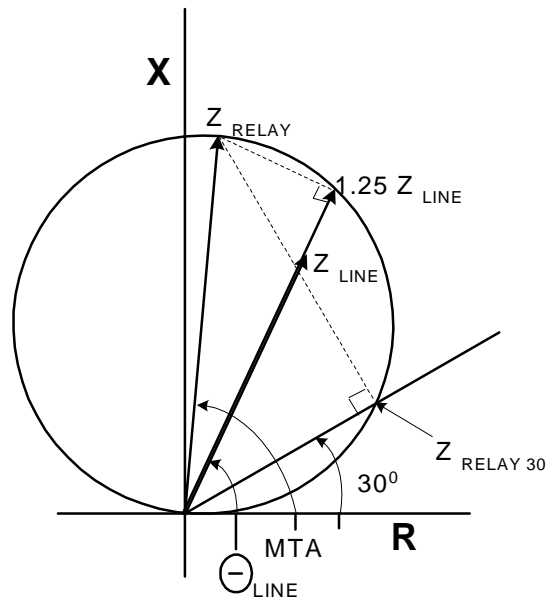

**Figure 7 – Long Line relay Loadability**

If this exception is required, it is prudent that the relays be adjusted to as close to the 90 degree MTA setting as the relay can be set to achieve the highest level of loadability without compromising the ability of the relay to reliably detect faults.

The basis for the emergency current loading is as follows:

$V_{relay}$  = Phase-to-phase line voltage at the relay location

$Z_{line}$  = Line impedance

$\Theta_{line}$  = Line impedance angle

$Z_{relay}$  = Relay setting at the maximum torque angle

$MTA$  = Maximum torque angle, the angle of maximum relay reach

$Z_{relay30}$  = Relay trip point at a 30 degree phase angle between the voltage and current

$I_{trip}$  = Trip current at 30 degrees with normal voltage

$I_{emergency}$  = Emergency current (including a 15% margin) that the circuit can carry at 0.85 per unit voltage at a 30 degree phase angle between the voltage and current before reaching the relay trip point

For applying a mho relay at any maximum torque angle to any line impedance angle:

$$Z_{relay} = \frac{1.25 \times Z_{line}}{\cos(MTA - \Theta_{line})}$$

The relay reach at the load power factor angle of 30° is determined from:

$$Z_{relay30} = \left[ \frac{1.25 \times Z_{line}}{\cos(MTA - \Theta_{line})} \right] \times \cos(MTA - 30^\circ)$$

The relay operating current at the load power factor angle of 30° is:

$$I_{trip} = \frac{V_{relay}}{\sqrt{3} \times Z_{relay30}}$$

$$I_{trip} = \frac{V_{relay} \times \cos(MTA - \Theta_{line})}{\sqrt{3} \times 1.25 \times Z_{line} \times \cos(MTA - 30^\circ)}$$

The emergency load current with a 15% margin factor and the 0.85 per unit voltage requirement is calculated by:

$$I_{emergency} = \frac{0.85 \times I_{trip}}{1.15}$$

$$I_{emergency} = \frac{0.85 \times V_{relay} \times \cos(MTA - \Theta_{line})}{1.15 \times \sqrt{3} \times 1.25 \times Z_{line} \times \cos(MTA - 30^\circ)}$$

$$I_{emergency} = \left( \frac{0.341 \times V_{relay}}{Z_{line}} \right) \times \left( \frac{\cos(MTA - \Theta_{line})}{\cos(MTA - 30^\circ)} \right)$$

For this exception:

The loadability requirement of lines that do not meet the thermal loadability requirement because of line length can be adjusted as long as ALL of the following conditions are met:

1. The most sensitive tripping relay is set for no more than 125% of the total line impedance.
2. The maximum torque angle ( $MTA$ ) of the relay is set as close to 90 degrees as possible, as sanctioned by the protective relay manufacturer.
3. The short-term emergency rating ( $I_{emergency}$ ) of the line is equal to or less than:

$$I_{emergency} = \left( \frac{0.341 \times V_{relay}}{Z_{line}} \right) \times \left( \frac{\cos(MTA - \Theta_{line})}{\cos(MTA - 30^\circ)} \right)$$

Where  $V$  is the nominal line-to-line voltage and  $Z_{line}$  is the impedance of the line in ohms.

4.  $I_{emergency}$  of the circuit is used in all planning and operational modeling for the short-term (15-minute or that most closely approximates a 15-minute) emergency rating.
5. No current or subsequent planning contingency analyses identify any conditions where the recoverable flow is greater than  $I_{emergency}$ .
6. Transmission Operators are instructed to take immediate remedial steps, including dropping load, if the current on the circuit reaches  $I_{emergency}$ .

If any of these conditions are violated, then the condition must be fully mitigated to avoid the loadability issue.

## Exception 8 — Three (or more) Terminal Lines and Lines with One or More Radial Taps

Three (or more) terminal lines present protective relaying challenges from a loadability standpoint due to the apparent impedance as seen by the different terminals. This includes lines with radial taps. For this exception, the loadability of the line may be different for each terminal of the line so the loadability must be done on a per terminal basis:

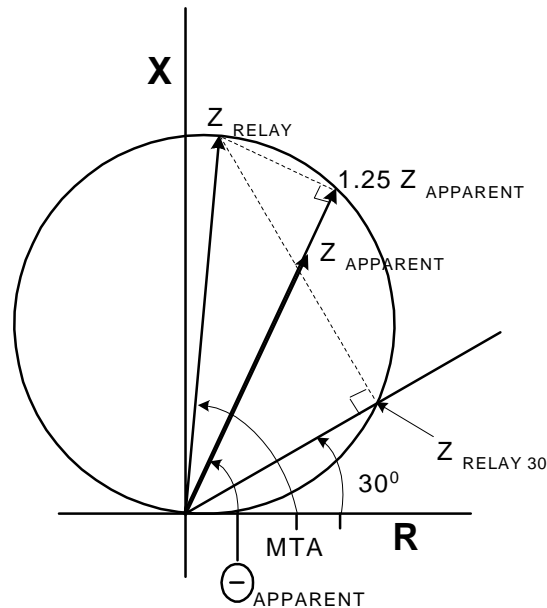

**Figure 8 – Three (or more) Terminal Lines and Lines with One or More Radial Taps**

The basis for the emergency current loading is as follows:

$V_{relay}$  = Phase-to-phase line voltage at the relay location

$Z_{apparent}$  = Apparent line impedance as seen from the line terminal. This apparent impedance is the impedance calculated (using in-feed where applicable) by the TPSO for a fault at the most electrically distant line terminal for system conditions normally used in their protective relaying setting practices.

$\Theta_{apparent}$  = Apparent line impedance angle as seen from the line terminal

$Z_{relay}$  = Relay setting at the maximum torque angle.

$MTA$  = Maximum torque angle, the angle of maximum relay reach

$Z_{relay30}$  = Relay trip point at a 30 degree phase angle between the voltage and current

$I_{trip}$  = Trip current at 30 degrees with normal voltage

$I_{emergency}$  = Emergency current (including a 15% margin) that the circuit can carry at 0.85 voltage at a 30 degree phase angle between the voltage and current before reaching the trip point

For applying a mho relay at any maximum torque angle to any apparent impedance angle



$$Z_{relay} = \frac{1.25 \times Z_{apparent}}{\cos(MTA - \Theta_{apparent})}$$

The relay reach at the load power factor angle of 30° is determined from:

$$Z_{relay30} = \left[ \frac{1.25 \times Z_{apparent}}{\cos(MTA - \Theta_{apparent})} \right] \times \cos(MTA - 30^\circ)$$

The relay operating current at the load power factor angle of 30° is:

$$I_{trip} = \frac{V_{relay}}{\sqrt{3} \times Z_{relay30}}$$

$$I_{trip} = \frac{V_{relay} \times \cos(MTA - \Theta_{apparent})}{\sqrt{3} \times 1.25 \times Z_{apparent} \times \cos(MTA - 30^\circ)}$$

The emergency load current with a 15% margin factor and the 0.85 per unit voltage requirement is calculated by:

$$I_{emergency} = \frac{0.85 \times I_{trip}}{1.15}$$

$$I_{emergency} = \frac{0.85 \times V_{relay} \times \cos(MTA - \Theta_{apparent})}{1.15 \times \sqrt{3} \times 1.25 \times Z_{apparent} \times \cos(MTA - 30^\circ)}$$

$$I_{emergency} = \left( \frac{0.341 \times V_{relay}}{Z_{apparent}} \right) \times \left( \frac{\cos(MTA - \Theta_{apparent})}{\cos(MTA - 30^\circ)} \right)$$

For this exception:

The loadability requirement for a terminal on a three terminal line that does not meet the thermal loadability requirement because of apparent impedance can be adjusted as long as ALL of the following conditions are met:

1. The most sensitive tripping relay is set for no more than 125% of the apparent impedance as seen by that terminal.
2. The maximum torque angle of the relay is set as close to 90 degrees as sanctioned by the protective relay manufacturer.
3. The short term emergency rating  $I_{emergency}$  of the line is:

$$I_{emergency} = \left( \frac{0.341 \times V_{relay}}{Z_{apparent}} \right) \times \left( \frac{\cos(MTA - \Theta_{apparent})}{\cos(MTA - 30^\circ)} \right)$$

Where  $V$  is the nominal line-to-line voltage and  $Z_{apparent}$  is the impedance of the line in ohms.

4.  $I_{emergency}$  of the circuit is used in all planning and operational modeling for the short-term (15-minute) emergency rating.
5. No current or subsequent planning contingency identifies any conditions where the recoverable flow is greater than  $I_{emergency}$ .
6. Transmission Operators are instructed to take immediate remedial steps including dropping load if the current on the circuit reaches  $I_{emergency}$ .

If any of these conditions are violated, then the condition must be fully mitigated to avoid the loadability issue.

## Exception 9 — Generation Remote to Load

Some system configurations have generation is remote to load centers or the main transmission busses. Under these conditions, the total generation in the remote area may limit the total available current from the area towards the load center. In the simple case of generation connected by a single line to the system (*Figure 9a*), the total capability of the generator determines the maximum current ( $I_{max}$ ) that the line will experience.

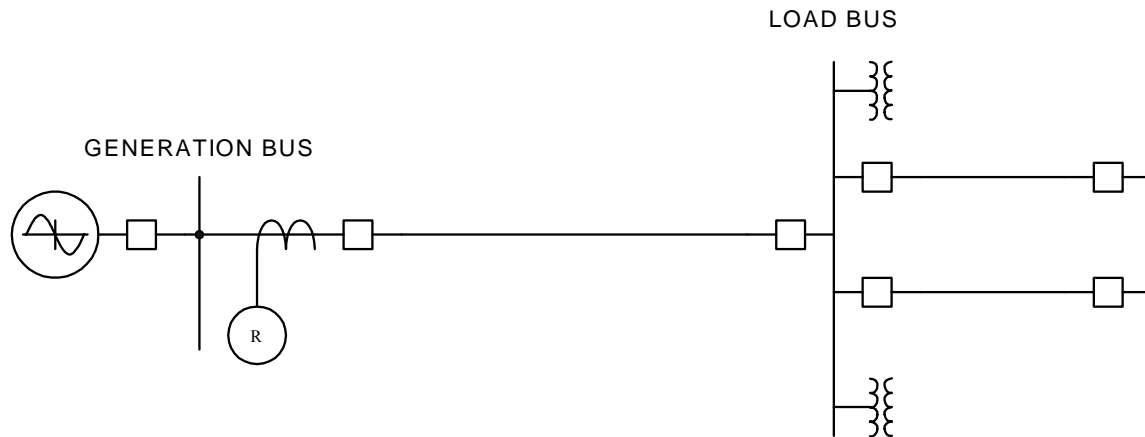

**Figure 9a – Generation Remote to Load Center**

For purposes of this exception the total generation output is defined as two times<sup>5</sup> the aggregate of the nameplate ratings of the generators in MVA converted to amps at the relay location at 100% voltage:

$$MVA_{max} = 2 \times \sum_1^N \frac{MW_{nameplate}}{PF_{nameplate}}$$

$$I_{max} = \frac{MVA_{max}}{\sqrt{3} \times V_{relay}}$$

Where:

$V_{relay}$  = Phase-to-phase voltage at the relay location

$N$  = Number of generators connected to the generation bus

<sup>5</sup> This has a basis in the PSRC paper titled: "Performance of Generator Protection During Major System Disturbances", IEEE Paper No. TPWRD-00370-2003, Working Group J6 of the Rotating Machinery Protection Subcommittee, Power System Relaying Committee, 2003. Specifically, page 8 of this paper states: "...distance relays [used for system backup phase fault protection] should be set to carry more than 200% of the MVA rating of the generator at its rated power factor."

For this exception:

The tripping relay should not operate at or below 1.15 times the  $I_{max}$ . When evaluating a distance relay, assume a 0.85 per unit relay voltage and a line phase (power factor) angle of 30 degrees.

$$\text{Example: } Z_{relay30} = \frac{0.85 \times V_{L-L}}{\sqrt{3} \times 1.15 \times I_{total}}$$

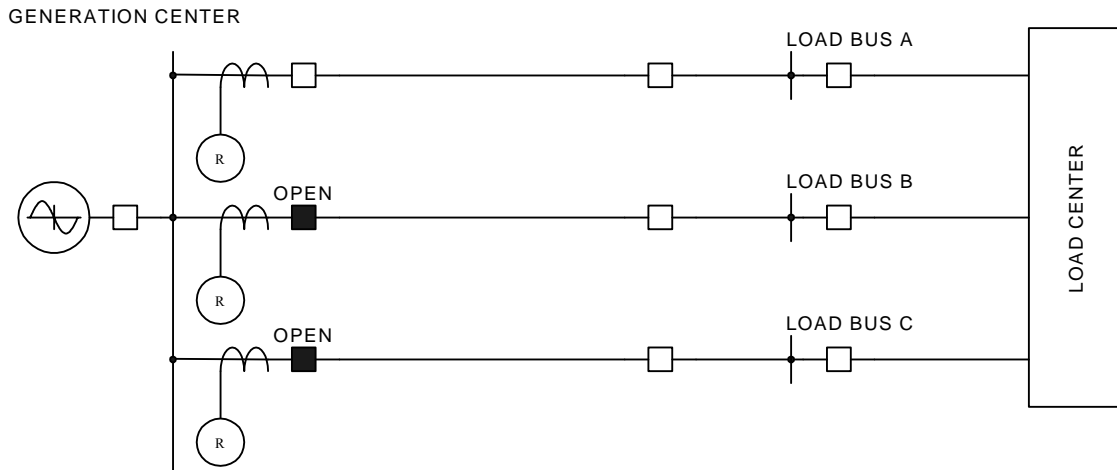

**Figure 9b – Generation Connected to System – Multiple Lines**

The same general principle can be used if the generator is connected to the system through more than one line (*Figure 9b*). The  $I_{max}$  expressed above also applies in this case. To qualify for this exception, all transmission lines except the one being evaluated must be open such that the entire generation output is carried across the single transmission line. In using this exception, the TPSO must also ensure that loop flow through the system cannot occur such that the total current in the line exceeds  $I_{max}$ .

For this exception:

The tripping relay should not operate at or below 1.15 times  $I_{max}$ , if all the other lines that connect the generator to the system are out of service. When evaluating a distance relay, assume a 0.85 per unit relay voltage and a line phase (power factor) angle of 30 degrees.

$$\text{Example: } Z_{relay30} = \frac{0.85 \times V_{L-L}}{\sqrt{3} \times 1.15 \times I_{total}}$$

## Exception 10 — Load Remote to Generation

Some system configurations have load centers (no appreciable generation) remote from the generation center where under no contingency, would appreciable current flow from the load centers to the generation center (*Figure 10*).

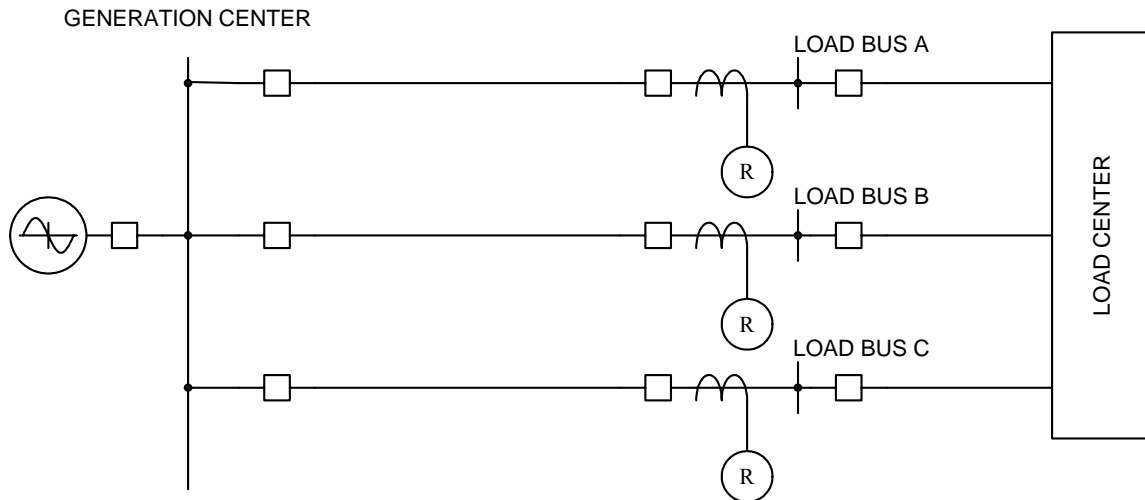

**Figure 10 – Load Remote to Generation**

Although under normal conditions, only minimal current can flow from the load center to the generation center, the forward reaching relay element on the load center breakers must provide sufficient loadability margin for unusual system conditions. To qualify for this exception, the TPSO must determine the maximum current flow from the load center to the generation center under any system contingency. The Reliability Coordinator must concur with this maximum flow.

For this exception:

The tripping relay should not operate at or below 1.15 times the maximum current flow as calculated by the TPSO. When evaluating a distance relay, assume a 0.85 per unit relay voltage and a line phase (power factor) angle of 30 degrees.

$$\text{Example: } Z_{\text{relay}30} = \frac{0.85 \times V_{L-L}}{\sqrt{3} \times 1.15 \times I_{\text{total}}}$$

## Exception 11 — Remote Cohesive Load Center

Some system configurations have one or more transmission lines connecting a cohesive, remote, net importing load center to the rest of the system. For the system shown in *Figure 11*, the total maximum load at the load center defines the maximum load that a single line must carry.

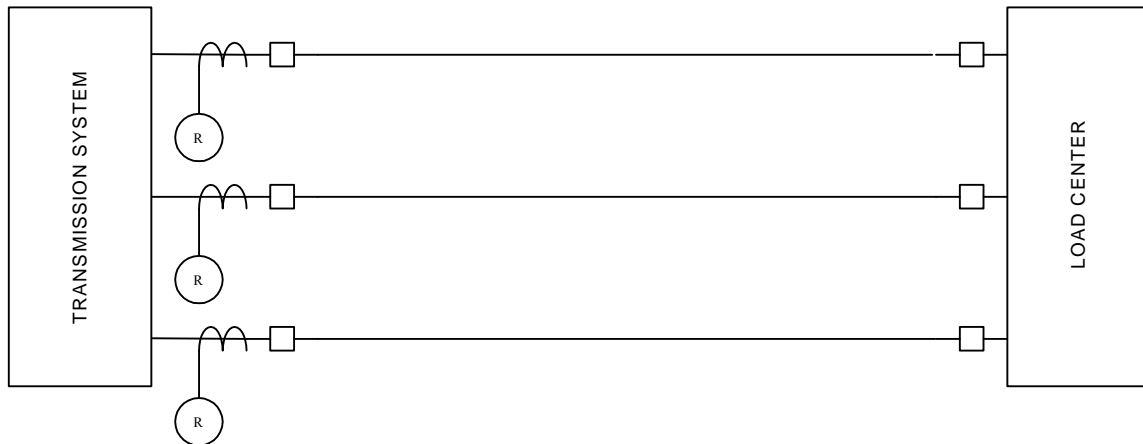

**Figure 11 – Remote Cohesive Load Center**

Also, to qualify for this exception, the TPSO must determine the maximum power flow on an individual line to the area ( $I_{maxload}$ ) under all system contingencies, reflecting any higher currents resulting from reduced voltages, and ensure that under no condition will loop current in excess of  $I_{maxload}$  flow in the transmission lines. The Reliability Coordinator must concur with this maximum flow.

For this exception:

The tripping relay should not operate at or below 1.15 times the maximum current flow as calculated by the TPSO. When evaluating a distance relay, assume a 0.85 per unit relay voltage and a line phase (power factor) angle of 30 degrees.

$$\text{Example: } Z_{relay30} = \frac{0.85 \times V_{L-L}}{\sqrt{3} \times 1.15 \times I_{total}}$$

## Exception 12 — Cohesive Load Center Remote to Transmission System

Some system configurations have one or more transmission lines connecting a cohesive, remote, net importing load center to the rest of the system. For the system shown in *Figure 12*, the total maximum load at the load center defines the maximum load that a single line must carry. This applies to the relays at the load center ends of lines addressed in Exception 9.



**Figure 12 – Cohesive Load Center Remote to Transmission System**

Although under normal conditions, only minimal current can flow from the load center to the electrical network, the forward reaching relay element on the load center breakers must provide sufficient loadability margin for unusual system conditions, including all potential loop flows. To qualify for this exception, the TPSO must determine the maximum current flow from the load center to the electrical network under any system contingency. The Reliability Coordinator must concur with this maximum flow.

For this exception:

The tripping relay should not operate at or below 1.15 times the maximum current flow as calculated by the TPSO. When evaluating a distance relay, assume a 0.85 per unit relay voltage and a line phase (power factor) angle of 30 degrees.

$$\text{Example: } Z_{relay30} = \frac{0.85 \times V_{L-L}}{\sqrt{3} \times 1.15 \times I_{total}}$$





# APPENDICES

## Long Line Maximum Power Transfer Equations

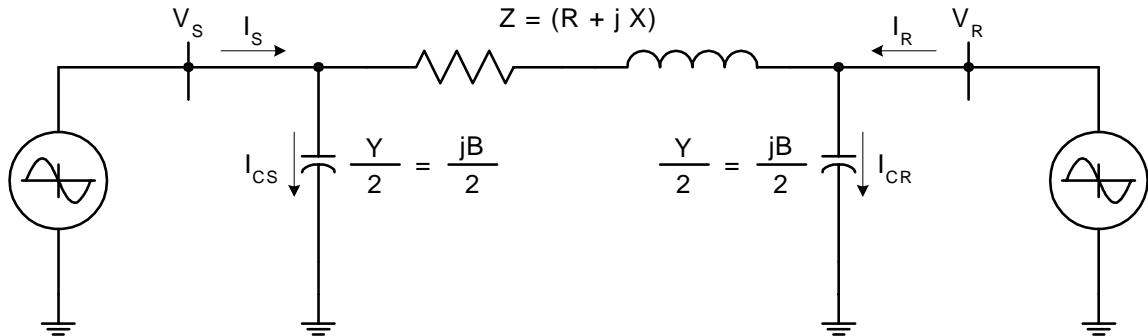

Lengthy transmission lines have significant series resistance, reactance, and shunt capacitance. The line resistance consumes real power when current flows through the line and increases the real power input during maximum power transfer. The shunt capacitance supplies reactive current, which impacts the sending end reactive power requirements of the transmission line during maximum power transfer. These line parameters should be used when calculating the maximum line power flow.

The following equations may be used to compute the maximum power transfer:

$$P_{S3-\phi} = \frac{V_S^2}{|Z|} \cos(\theta^\circ) - \frac{V_S V_R}{|Z|} \cos(\theta + \delta^\circ)$$

$$Q_{S3-\phi} = \frac{V_S^2}{|Z|} \sin(\theta^\circ) - V_S^2 \frac{B}{2} - \frac{V_S V_R}{|Z|} \sin(\theta + \delta^\circ)$$

The equations for computing the total line current are below. These equations assume the condition of maximum power transfer,  $\delta = 90^\circ$ , and nominal voltage at both the sending and receiving line ends:

$$I_{real} = \frac{V}{\sqrt{3}|Z|} (\cos(\theta^\circ) + \sin(\theta^\circ))$$

$$I_{reactive} = \frac{V}{\sqrt{3}|Z|} \left( \sin(\theta^\circ) - |Z| \frac{B}{2} - \cos(\theta^\circ) \right)$$

$$I_{total} = I_{real} + jI_{reactive}$$

$$I_{total} = \sqrt{I_{real}^2 + I_{reactive}^2}$$

Where:

$P$  = the power flow across the transmission line

$V_S$  = Phase-to-phase voltage at the sending bus

$V_R$  = Phase-to-phase voltage at the receiving bus

$V$  = Nominal phase-to-phase bus voltage

$\delta$  = Voltage angle between  $V_S$  and  $V_R$

$Z$  = Reactance, including fixed shunt reactors, of the transmission line in ohms\*

$\Theta$  = Line impedance angle

$B$  = Shunt susceptance of the transmission line in mhos\*

\* The use of hyperbolic functions to calculate these impedances is recommended to reflect the distributed nature of long line reactance and capacitance.

## Related Reading and References

The following related IEEE technical papers are available at:

<http://pes-psrc.org>

under the link for "Published Reports"

The listed IEEE Standards are available from the IEEE Standards Association at:

<http://shop.ieee.org/ieeestore>

The listed ANSI Standards are available directly from the American National Standards Institute at

<http://webstore.ansi.org/ansidocstore/default.asp>

1. *Performance of Generator Protection During Major System Disturbances*, IEEE Paper No. TPWRD-00370-2003, Working Group J6 of the Rotating Machinery Protection Subcommittee, Power System Relaying Committee, 2003.
2. *Transmission Line Protective Systems Loadability*, Working Group D6 of the Line Protection Subcommittee, Power System Relaying Committee, March 2001.
3. *Practical Concepts in Capability and Performance of Transmission Lines*, H. P. St. Clair, IEEE Transactions, December 1953, pp. 1152–1157.
4. *Analytical Development of Loadability Characteristics for EHV and UHV Transmission Lines*, R. D. Dunlop, R. Gutman, P. P. Marchenko, IEEE transactions on Power Apparatus and Systems, Vol. PAS –98, No. 2 March-April 1979, pp. 606–617.
5. *EHV and UHV Line Loadability Dependence on var Supply Capability*, T. W. Kay, P. W. Sauer, R. D. Shultz, R. A. Smith, IEEE transactions on Power Apparatus and Systems, Vol. PAS –101, No. 9 September 1982, pp. 3568–3575.
6. *Application of Line Loadability Concepts to Operating Studies*, R. Gutman, IEEE Transactions on Power Systems, Vol. 3, No. 4 November 1988, pp. 1426–1433.
7. IEEE Standard C37.113, *IEEE Guide for Protective Relay Applications to Transmission Lines*
8. ANSI Standard C50.13, *American National Standard for Cylindrical Rotor Synchronous Generators*.
9. ANSI Standard C84.1, *American National Standard for Electric Power Systems and Equipment – Voltage Ratings (60 Hertz)*, 1995
10. IEEE Standard 1036, *IEEE Guide for Application of Shunt Capacitors*, 1992.
11. J. J. Grainger & W. D. Stevenson, Jr., *Power System Analysis*, McGraw- Hill Inc., 1994, Chapter 6 Sections 6.4 – 6.7, pp 202 – 215.
12. *Final Report on the August 14, 2003 Blackout in the United States and Canada: Causes and Recommendations*, U.S.-Canada Power System Outage Task Force, April 2004.
13. *August 14, 2003 Blackout: NERC Actions to Prevent and Mitigate the Impacts of Future Cascading Blackouts*, approved by the NERC Board of Trustees, February 10, 2004

## System Protection and Control Task Force

**Charles W. Rogers***Chairman / ECAR Representative*

Principal Engineer

Consumers Energy Co.

**W. Mark Carpenter***Vice Chairman / ERCOT Representative*

System Protection manager

TXU Electric Delivery

**John Mulhausen***FRCC Representative*

Florida Power &amp; Light Co.

**Joseph M. Burdis***MAAC Representative*Senior Consultant / Engineer, Transmission  
and Interconnection Planning

PJM Interconnection, L.L.C.

**William J. Miller***MAIN Representative*

Consulting Engineer

Exelon Corporation

**Deven Bhan***MAPP Representative*

System Protection Engineer

Western Area Power Administration

**Philip Tatro***NPCC Representative*

Consulting Engineer

National Grid USA

**Philip B. Winston***SERC Representative*

Manager, Protection and Control

Georgia Power Company

**Fred Ipock***SPP Representative*

Senior Engineer – Substation Engineering

City Utilities of Springfield, Missouri

**David Angell***WSCC Representative*

System Protection &amp; Communications Leader

Idaho Power Company

**John L. Ciuffo***Canada Member-at-Large*

Team Leader – P&amp;C / Telecom

Hydro One, Inc.

**W. O. (Bill) Kennedy***Canada Member-at-Large*

Principal Engineer

Alberta Electric System Operator

**Jim Ingleson***ISO / RTO Representative*

Senior Operations Engineer

New York Independent System Operator

**Evan T. Sage***Investor Owned Utility*

Senior Engineer

Potomac Electric Power Company

**Gary L. Kobet***Federal*

Project Specialist – System Protection

Tennessee Valley Authority

**Keith Orsted***Transmission Dependant Utility*

American Transmission Co., LLC

**Bob Stuart***NERC Blackout Investigation Team*

Principal

Nexant, Inc.

**Tom Wiedman***NERC Blackout Investigation Team*

Consultant to NERC

**Jerome. (Skip) Williams***ECAR Alternate*

Sr. Engineer

American Electric Power

**Albert N. Darlington***FRCC Alternate*

Consultant to FRCC

**Baj Agrawal**

*WECC Alternate*

Principal Engineer

Arizona Public Service Company

**Jon Daume**

*WECC Alternate*

System Protection & Control Engineer

Bonneville Power Administration

**Robert W. Cummings**

*Staff Coordinator*

Director – Reliability Performance and Engineering

Support

North American Electric Reliability Council