

NERC

NORTH AMERICAN ELECTRIC
RELIABILITY CORPORATION

A Technical Paper

Protection System Reliability

Redundancy of Protection System Elements

NERC System Protection and Control Task Force

to ensure
the reliability of the
bulk power system

November 2008

116-390 Village Blvd., Princeton, NJ 08540
609.452.8060 | 609.452.9550 fax
www.nerc.com

Table of Contents

1. Introduction.....	4
1.1 <i>The Need for a Protection System Reliability (Redundancy) Standard.....</i>	<i>5</i>
2. Protection System Reliability.....	6
2.1 <i>Dependability and Security.....</i>	<i>6</i>
2.2 <i>Need for Protection Reliability.....</i>	<i>8</i>
2.3 <i>Protection System Redundancy.....</i>	<i>9</i>
3. Reliability of the Bulk Electric System.....	11
3.1 <i>2002 NERC Planning Standards.....</i>	<i>12</i>
3.2 <i>Clearing Times.....</i>	<i>13</i>
3.2.1 <i>Normal Clearing Time.....</i>	<i>14</i>
3.2.2 <i>Breaker Failure or Stuck Breaker Clearing Time.....</i>	<i>14</i>
3.2.3 <i>Delayed Clearing Time.....</i>	<i>15</i>
3.2.4 <i>Planning Standard Development.....</i>	<i>15</i>
4. Proposed Protection System Reliability (Redundancy) Requirements.....	16
4.1 <i>Evaluating BES Performance.....</i>	<i>17</i>
4.2 <i>Development of a Testing Methodology to Determine the Need for Redundancy.....</i>	<i>20</i>
4.2.1 <i>Determine Redundancy of the Protection System.....</i>	<i>21</i>
4.2.2 <i>Determining Performance of the Protection System.....</i>	<i>25</i>
4.2.3 <i>Compare BES Performance with Requirements of the TPL Standards.....</i>	<i>27</i>
4.2.4 <i>Mitigate All Violations of the TPL Standards.....</i>	<i>28</i>
5. Protection System Components.....	30
5.1 <i>AC Current Source.....</i>	<i>33</i>
5.2 <i>AC Voltage Source.....</i>	<i>37</i>
5.3 <i>Protective Relay.....</i>	<i>40</i>
5.4 <i>Communication Channel.....</i>	<i>41</i>
5.5 <i>DC Control Circuitry.....</i>	<i>44</i>
5.6 <i>Auxiliary Relay.....</i>	<i>46</i>
5.7 <i>Breaker Trip Coil.....</i>	<i>47</i>
5.8 <i>DC Source.....</i>	<i>48</i>
Appendix A – DC FAILURE (Loss of Station DC Supply).....	51
Appendix B – Excerpts from the 1997 NERC Transmission Planning Standards System Performance Requirements	54
<i>NERC 1997 Planning Standards Table 1.....</i>	<i>55</i>

NERC 2005 TPL Standards (Table I from TPL-001 – TPL-004).....56

Appendix C – System Protection and Control Subcommittee.....58

List of Figures

Figure 2-1 — Dependability-Type Failure (no trip) of a Protection System 7

Figure 2-2 — Security-Type Failure (overtrip) of a Protection System 8

Figure 2-3 — Non-Redundant Protection System 10

Figure 2-4 — Fully Redundant Protection System 10

Figure 4-1 — Acceptable Delayed Clearing Example 18

Figure 4-2 — Unacceptable Delayed Clearing Example 19

Figure 4-3 — Example 1 – Study of Protection System Reliability for Non-Redundant Systems 21

Figure 4-4 — Example 2 – Study of Protection System Reliability Redundancy for Redundant Systems 24

Figure 4-5 — Example 3 – Determining Protection Systems Performance 26

Figure 5-1 — Strong Source System One Line 31

Figure 5-2 — Weak Source System One Line 31

Figure 5-3 — Example of Redundant CTs 33

Figure 5-4 — Alternate CT Configuration with Single Point of Failure at the Main CT i

Figure 5-5 — Redundant CT Configuration 35

Figure 5-6 — AC Voltage Inputs 38

Figure 5-7 — Communication System 42

Figure 5-8 — Faults Near a Generating Station 43

Figure 5-9 — Station DC Supply and DC Control Circuits Boundary 45

Figure 5-10 — Non-Redundant DC Control Circuits 46

Figure 5-11 — Trip Coil Development 48

Figure 5-12 — Station DC Supply and Monitoring 50

Figure A-1 — Normal Clearing 51

Figure A-2 — Complete Loss of DC with Remote Clearing 53

List of Tables

Table 4-3 — Example 1 – Study of Protection System Reliability for Non-Redundant Systems 22

Table 4-4 — Example 2 – Study of Protection System Reliability Redundancy for Redundant Systems 25

Table 4-5 — Example 3 – Determining Protection Systems Performance 26

Table 4.6 — Acceptable Clearing Times 28

This Technical Reference Paper was approved by the NERC Planning Committee on December 4, 2008.

1. Introduction

The 1997 NERC Planning Standards¹ contained tenets on Protection System redundancy that were not included in the Version 0 translation of those standards. Consequently, the NERC Planning Committee charged the System Protection and Controls Task Force (SPCTF) in late 2005 with preparing a Standard Authorization Request (SAR), with associated justifying technical background material, to reintroduce Protection System redundancy. This technical paper provides the background and support for the development of that Protection System Reliability SAR.

“Redundancy, in the context of this paper, further specifies that the fault clearing will meet the system performance requirements of the NERC Reliability Standards.”

The reliability of the Bulk Electric System (BES) is normally measured by determining the performance of all the various power system elements and their ancillary systems. Protection Systems, being ancillary systems, are critical to establishing and maintaining an adequate level of BES reliability. The NERC reliability standards define the level of reliability to which each owner must design the BES and this in turn, can be used to determine the performance requirements of electric system elements such as breakers, and Protection Systems.

“...the Protection Systems must operate and clear faults within the required clearance time to satisfy the proposed performance requirements...”

This paper, developed by the NERC System Protection and Control Task Force (SPCTF), proposes Protection System reliability requirements and discusses the reasoning behind the requirements, provides examples and explanations concerning each requirement, and describes how to determine the level of Protection System reliability necessary to meet each requirement. This paper also describes a collaborative and interactive process between the protection and planning engineers to determine the required level of

Protection System performance. It should be noted that in parallel to this effort is an IEEE PES/PSRC work group² that is developing a special report addressing redundancy considerations for relaying. SPCTF has a liaison relationship with that working group. The IEEE effort concentrates on the Protection System elements while this paper concentrates on the BES performance implications of Protection System redundancy.

¹ NERC Planning Standard, Section III – System Protection and Control, September 1997

² IEEE/PES/PSRC I19 Working Group

This paper evaluates Protection System clearing times for a normal electric system configuration (planned peak load conditions with all lines in service, typical generation dispatch, typical interchange, and typical switching configuration) for a fault on one electric system element with a Protection System component failure. For a component failure of the Protection System, redundant local backup, and remote backup Protection Systems are evaluated to determine the clearing time for the faulted electric system element under review. Due to the additional complexities involved, the performance requirements of backup Protection Systems for other electric system contingencies are not addressed in this paper.

1.1 The Need for a Protection System Reliability (Redundancy) Standard

Protection System reliability has been incorporated in NERC standards for decades and, in most situations, has been achieved through and referred to as redundancy. Redundancy is defined as “the existence of more than one means for performing a given function³.” The NERC Planning Standards (see Appendix C) contains references to “delayed clearing” and Protection System failures, however, these terms were not clearly defined and often were interpreted to be synonymous with operation of breaker failure protection. Breaker Failure protection has a predictable result and designed tripping times. Protection System failures can lead to a more severe system response as a result of longer fault clearing and more electric system elements being removed from service to clear the fault. In later sections of the old planning standard⁴, owners were required to incorporate redundancy in the Protection Systems as necessary to meet the reliability performance table (Table I. Transmission Systems Standards; C Normal and Contingency Conditions). References were made to various components of the Protection Systems that needed to have redundancy but no requirements were listed.

The old standards were vague and incomplete and did not directly correlate the need for redundancy to desired BES performance. It is necessary that a new approach be introduced to address the performance of the Protection System and provide the owner with clear tests and measures that can be used to determine when the application of redundancy is necessary. This technical paper has been developed to provide clarity on Protection System redundancy requirements, based on the relationship between performance of the Protection System and the performance of the BES. The approach introduced in this paper moves away from a prescriptive

³ IEEE Standard C37.100-1992.

⁴ NERC Planning Standard, Section III – System Protection and Control, September 1997

requirement based on a certain class or category of Protection Systems for specific voltage levels or generation amounts.

Local redundancy of components plays a major role in elevating the reliability of Protection Systems; however, it is not the only mitigation that can be used to improve the reliability of Protection Systems. Remote Protection Systems may provide adequate Protection System reliability in some situations, provided that remote protection can detect faults and provide clearing times that meet performance requirements. It is the task of the protection and the planning engineers to determine the proper solution for each element (lines, buses, transformers) and in most situations, there may not be any change required to the Protection Systems that are currently installed. New and existing Protection Systems need to be examined and upgraded when they lack the performance necessary to maintain an adequate level of BES reliability.

2. Protection System Reliability

2.1 Dependability and Security

There are two facets to Protection System reliability; dependability and security as defined by IEEE standard C37.100–1992 and are shown below:

- **Dependability** — “The facet of reliability that relates to the degree of certainty that a relay or relay system will operate correctly.” For purposes of this paper, dependability is a measure of the degree of certainty that a protective system will operate correctly when required, and at the designed speed. Dependability is a concern when a fault occurs within the protected zone.
- **Security** — “That facet of reliability that relates to the degree of certainty that a relay or relay system will not operate incorrectly.” For purposes of this paper, security is a measure of the degree of certainty that a Protection System will not operate incorrectly or faster than designed. Security is a concern for external faults and normal (unfaulted) operating conditions.

Protection Systems must be fundamentally designed to be both dependable and secure because it is presumed that components of the Protection System can sometimes fail. Overall design must strike a balance between dependability and security.

To illustrate the concept of a dependability-based failure, refer to Figure 2–1. Dependability based Protection System failures can result in longer fault clearing times and isolation of additional elements of the electric system. The relay at Sub 2 on Line 1 has failed and cannot

operate to clear the fault. Backup and time delayed relaying will be required to clear this fault and the loss of the generator is inevitable. Relaying at Sub 3 and Sub 4 will need to sense the fault and operate. This gets more difficult as the apparent impedance from the sensing relay to the fault gets larger and in some situations the remote relays will operate sequentially or may not operate at all.

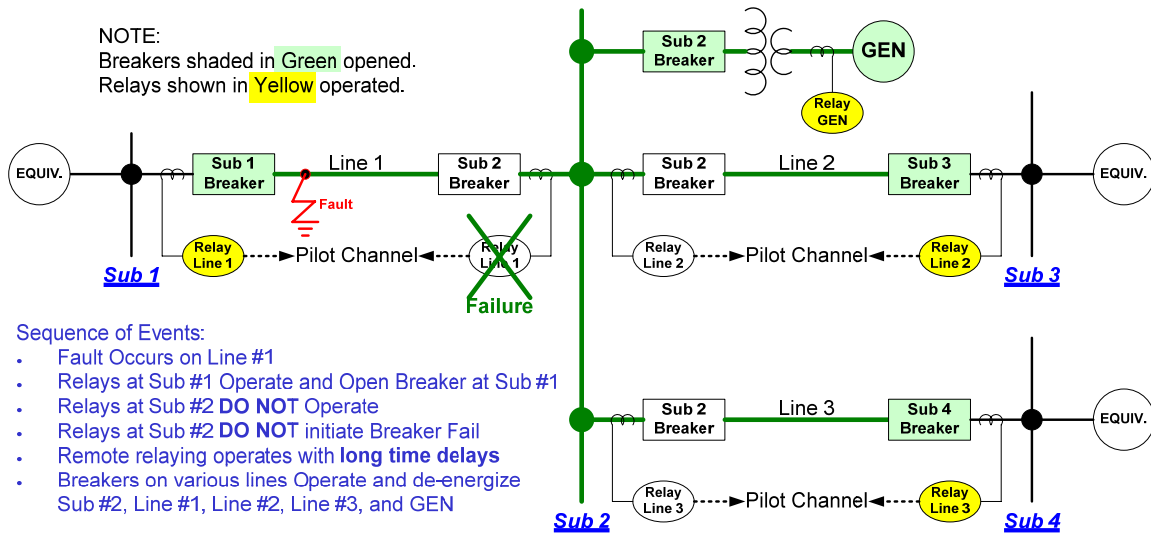

Figure 2-1 — Dependability-Type Failure (no trip) of a Protection System

In contrast, security-based Protection System failures can result in isolation of additional elements of the electric system as shown in Figure 2–2, but typically do not result in increased fault clearing time. In the last few years major system disturbances have been associated with both dependability and security based Protection System failures. However, this generally removes additional power system elements from service to clear the fault.

While redundancy reduces the probability of a dependability-based Protection System failure, it also increases the probability of a security based Protection System failure. Multiple Protection Systems provide a greater opportunity for an errant operation during a fault. For this reason, Protection System designs must provide a balance between dependability and security.

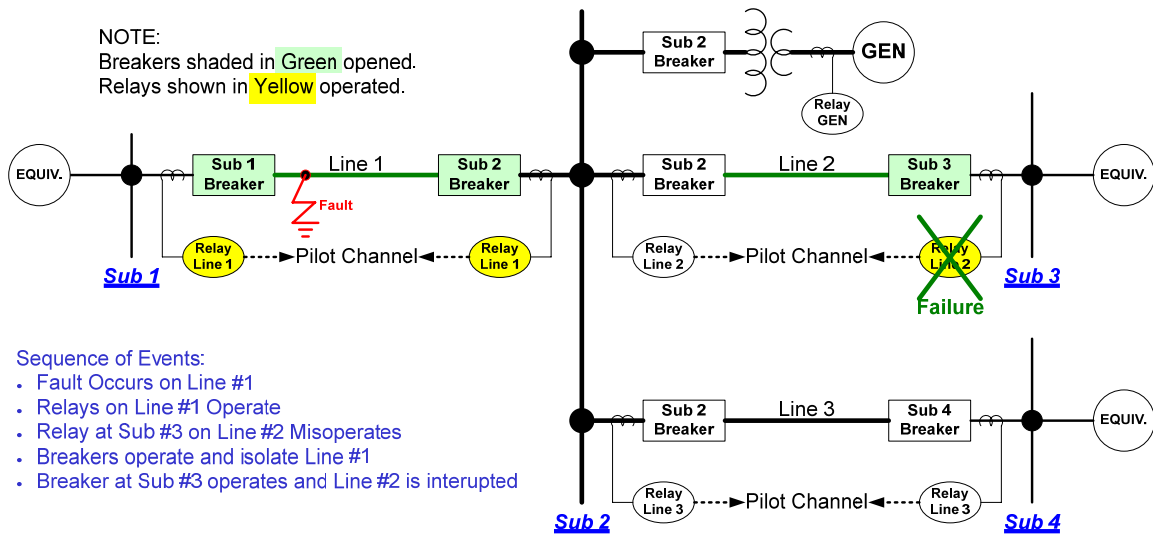

Figure 2–2 — Security-Type Failure (overtrip) of a Protection System

2.2 Need for Protection Reliability

The electric system network designs are planned and constructed to limit failure modes and equipment damage, and thereby enhance overall system reliability. The electric system is designed to balance performance and minimize the total transport cost of energy, which requires balancing of initial capital costs and long-term maintenance costs with the potential cost impact of a Protection System failure.

The design of Protection Systems must consider redundant components as a means to increase protection reliability, to minimize the impact of failures and allow the protection of an element to be returned to an acceptable level of performance and reliability. When a critical element of the electric system fails, the result can be catastrophic if additional equipment and Protection Systems are not available to minimize the impact. Electric system elements can be damaged, customer loads interrupted, instability on the grid can arise, and, in the worst case, blackouts can occur. Some equipment can require long lead times to repair or replace and electric system restoration can be time consuming if repair or replacement equipment is not readily available.

The power industry uses a practice of having redundant equipment available to quickly isolate problems, and spare equipment to return the electric system to normal operation. The application of breaker failure schemes with breaker-and-a-half, double-breaker lines, or main and transfer buses is an example of this. These designs utilize redundant or backup breakers to isolate the fault, and if one of the breakers is damaged and cannot quickly be returned to service, it can be

isolated and the alternate breaker or bus can be used to restore the electric system to stable operation.

It is not economically feasible to design an electric system to withstand all possible equipment failures and abnormal operating conditions. Therefore, all electric systems must deploy highly reliable Protection Systems that can quickly detect abnormal conditions and take appropriate actions to ensure removal of electric system faults. Protection System reliability is normally achieved by designing Protection Systems with adequate redundancy of equipment and functional adaptability to minimize single component failures, such as automatically decreasing the zone 2 timer for loss of a Protection System communication channel.

2.3 Protection System Redundancy

A fundamental concept of redundancy is that Protection Systems need to be designed such that electric system faults will be cleared, even if a component of the Protection System fails. Redundancy is a system design that duplicates components and/or systems to provide alternatives in case one component and/or system fails. ***“Redundancy,” in the context of this paper, further specifies that the fault clearing will meet the system performance requirements of the NERC Reliability Standards.***

Relay Terminology

Most Elements on the bulk power system are protected by multiple Protection Systems and the names applied to the multiple protection systems include: Primary, Secondary, Backup, Local Backup, Remote Backup, System A and B, System 1 and 2.

This paper refers to paired relaying systems as primary and secondary, #1 and #2, and A and B. Each of these systems must meet the performance requirements, such as minimum clearing times, but may have different operating principals and equipment. For example, if high speed operation and sensing on 100 percent of the line is needed, both paired relaying systems are required to provide this type of performance.

Backup relaying provides a different role than paired relayed systems and usually has less speed and maybe less selectivity. In this paper, the term backup relaying refers to protection that is installed to operate when paired relaying systems are not available and can be located locally or remotely.

Redundancy means that two or more functionally equivalent Protection Systems are used to protect each electric system element. Redundancy can be achieved in a variety of ways depending on the performance required and the infrastructure available. In some cases redundancy means that there are two locally independent Protection Systems that have no common single points of failure. This solution is usually applied when performance requires high-speed isolation of faults, or if the electric system cannot withstand longer fault clearing times and/or over-tripping for Protection System failures. When time delayed clearing of faults is sufficient to meet reliability performance requirements, owners may deploy one primary and

one remote or local backup system to meet reliability levels. Owners often refer to these systems as primary and secondary or backup systems. In both cases, *the Protection Systems must operate and clear faults within the required clearance time to satisfy the proposed performance requirements* (see section 4.0).

Figure 2–3 shows a simple non-redundant Protection System and Figure 2–4 shows a fully redundant Protection System. It should be noted that the single Protection System shown in Figure 2–3 could be sufficient to maintain reliability if there are sufficient remote backup Protection Systems that can operate to isolate the fault and maintain reliability.

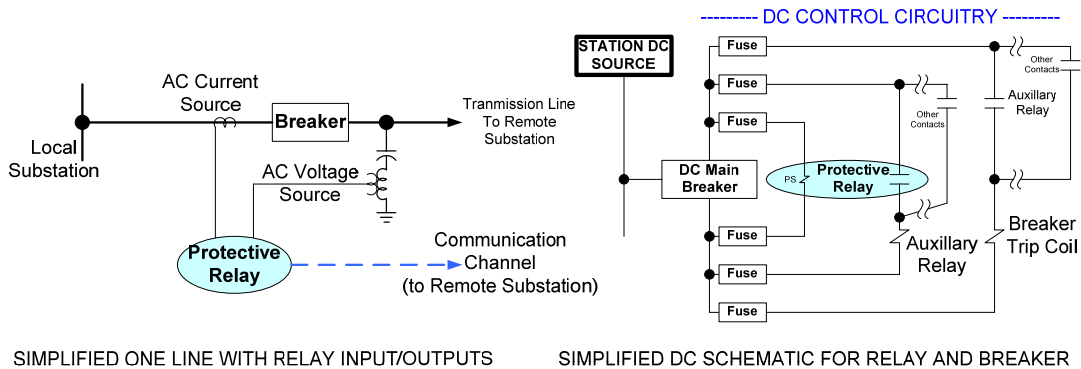

Figure 2–3 — Non-Redundant Protection System

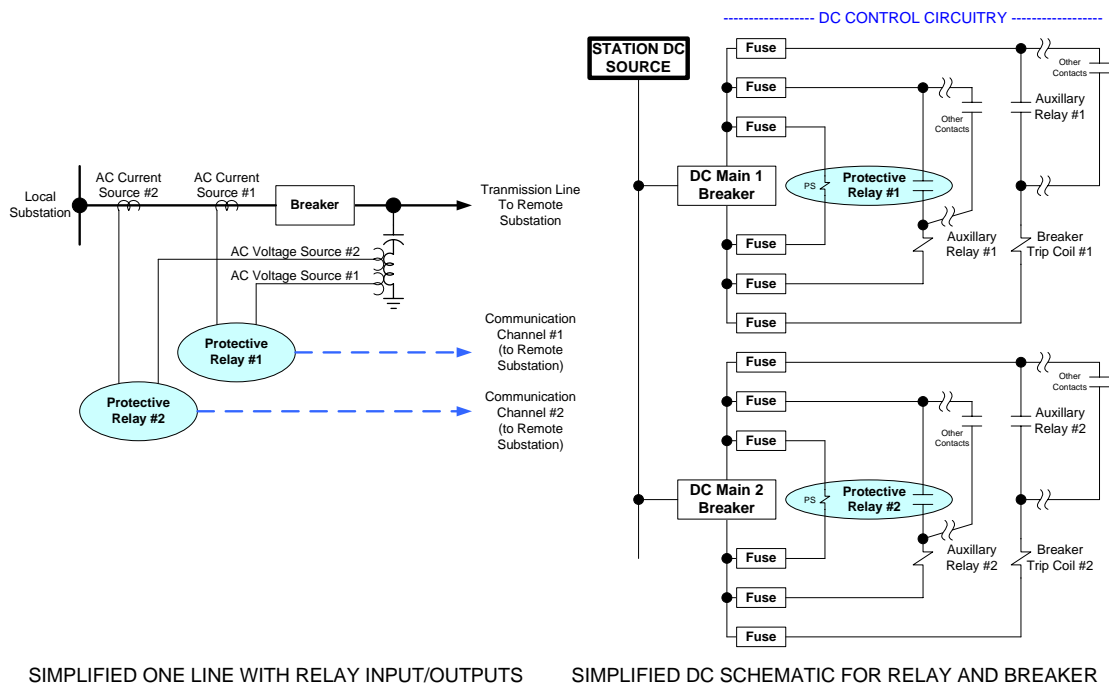

Figure 2–4 — Fully Redundant Protection System

The following are some examples of redundant protection applications.

- Multiple Protection Systems of similar functionality (tripping speeds) may be used to satisfy the performance requirements. For example, when high-speed clearing is required, the use of a current differential scheme with a Permissive Overreach Transfer Trip (POTT) or Directional Comparison Blocking (DCB) scheme as a second scheme can provide the necessary redundancy.
- Multiple Protection Systems with varying functionality may be used if one system has functionality in excess of what is needed to satisfy the performance requirements. For example, the Protection Systems may consist of one pilot Protection System (for high speed clearing of the entire circuit), with a second system using stepped-distance non-pilot protection, if the stepped-distance system itself meets the requirements to satisfy the performance requirements.
- Separate Protection Systems of varying functionality can be used where one system is enabled upon failure of the other system. For example, high-speed overcurrent relays that are enabled upon loss of a pilot communication system may be used if the overcurrent relays satisfy the performance requirements. However, this application method may introduce a possibility of over tripping due to the failure of the pilot scheme. Both failure modes must be checked to assure that they meet performance requirements.
- Local or remote backup protection may be used to satisfy redundancy, where the backup protection itself satisfies the reliability performance requirements.

3. Reliability of the Bulk Electric System

The reliability performance design requirements of the electric system are defined by the NERC TPL standards for the planning horizon. That performance is based on various criteria that determine acceptable conditions for BES performance under system normal conditions and after various system contingencies.

NERC has also published a document that explains the concept of Adequate Level of Reliability (ALR)⁵ across all planning and operating horizons, allowing various standards to reference and use common concepts to determine reliability performance requirements. The adequate level of reliability centers on the following criteria:

- The System remains within acceptable limits;

⁵ “Characteristics of a System with an Adequate Level of Reliability,” approved by the NERC Board of Trustees in February 2008, and filed with the FERC.

- The System performs acceptably after credible contingencies⁶;
- The System limits instability and cascading outages;
- The System’s facilities are protected from severe damage; and
- The System’s integrity can be restored if it is lost.

To ensure that Protection Systems installed on the electric system meet those tenets, the approach introduced in this paper requires Protection Systems to be designed such that no single Protection System component failure would prevent the BES from meeting system performance requirements in the NERC Reliability Standards.

- This Technical Paper is devoted to the methods for evaluating the application of Protection System redundancy and its resultant impact on BES performance for faults occurring starting from electric system normal conditions (planned peak load conditions with all lines in service, typical generation dispatch, typical interchange, and typical switching configuration). The need for redundancy is determined by examining Protection System performance in light of Protection System element failures and whether or not the resultant BES performance is acceptable to meet the proposed performance requirements (see Section 4.0 of this document).

This paper does not cover all aspects of Protection System reliability. For example, it does not prescribe methods for setting the Protection System or the application of remote backup protection, and does not address the potentially special protection needs of circuits that are part of the “cranking path” for power system restoration.

3.1 2002 NERC Planning Standards

The current NERC Planning Standards (TPL-001 through TPL-004) were developed as part of the “Version 0” standards in 2002. Those standards are soon to be consolidated into a single standard that refines the categories of contingencies, applicable conditions, and performance requirements. Changes under consideration include more prescriptive information regarding how Protection Systems are to be considered. The Version 0 planning standards did not consider Protection System failures for normal operation of the electric system, and separated outages and conditions into four categories which are paraphrased below.

Category A — No Contingencies (all facilities in service)

- Facility rating must be maintained (thermal and voltage)
- The system must remain stable

⁶ Beyond the scope of this document.

- No Loss of demand or firm transfers allowed
- No Cascading allowed

Category B — Event resulting in the loss of a single element

A category B event can be a single-line-to-ground or three-phase fault with the Protection System operating normally, with normal or designed clearing times. The transmission system is required to remain stable with all equipment loaded to within its applicable operating limits, and with no load shedding or cascading outages.

- Facility rating must be maintained (thermal and voltage)
- The system must remain stable
- No Loss of demand or firm transfers allowed
- No Cascading allowed

Category C — Events resulting in the loss of two or more elements.

A category C event can be a single-line-to-ground fault on a bus section or a breaker failure with the Protection System operating normally, with normal or designed clearing times. It also can be independent events when single-line-to-ground or three-phase faults occur on multiple elements with time for manual system adjustments between events, or a single-line-to-ground fault with a Protection System failure. In this case, some controlled load shedding is acceptable. Acceptable system performance requires that:

- Facility rating must be maintained (thermal and voltage)
- The system must remain stable
- Only Planned or Controlled Loss of demand or firm transfers allowed
- No Cascading allowed

Category D — Extreme event resulting in two or more elements removed or cascading out of service

A category D event can be a catastrophic failure of a piece of equipment or a three-phase fault preceding a breaker failure with a Protection System failure.

- Loss of Customer Demand and Generation may occur
- The system is not required to return to a stable operating point

3.2 Clearing Times

The planning engineer typically considers three levels of Protection System performance: Normal Clearing Time, Breaker Failure Clearing Time, and Delayed Clearing Time. In the planning standards, the performance requirements vary based on the combined probability of an electric system event

Breaker Failure and Delayed Clearing

According to the NERC Glossary of Terms, Delayed Fault Clearing is defined as “Fault clearing consistent with correct operation of a breaker failure protection system and its associated breakers, or of a backup protection system with an intentional time delay.”

For purposes of this paper, delayed clearing times are differentiated into the two components of that definition. This section describes the differences.

For example, zone 2 clearing for a line end fault would be considered normal clearing when the line is protected by stepped-distance protection, but would be considered delayed clearing when the line is protected by high-speed pilot protection with stepped-distance protection as backup if the high speed scheme did not operate.

occurring, and the level of Protection System performance under consideration.

Categories A and B in the 2005 Version 0 Standards consider that the Protection System operates normally. Category C considers breaker failure and some delayed clearing times due to Protection System failure. Category D takes in account multiple contingencies including breaker failure and Protection System failure. The planning engineer must consult with the protection engineer to correctly model the Protection System performance in those system studies.

3.2.1 Normal Clearing Time

Normal clearing time is a Protection System mode of operation that does not take into consideration Protection System failure, and assumes that the Protection System is fully functional and will operate as designed and intended. Normal clearing time for the Protection System is based on the time in which each Protection System component is expected and designed to operate. For example, a communication aided Protection System is design to provide instantaneous operation (without intentional time delay) for all faults on the line. The normal clearing time for this example might be 4 cycles (2 cycles for relay time and 2 cycles for breaker time). Fault location must also be considered in determining worst case clearing times. For example if a line is protected by step distance protection (non-pilot), faults at the end of the line would be cleared by time delayed relaying and the normal clearing time for this fault might be 22 cycles (2 cycles for relay time, 18 cycles for intentional time delay, and 2 cycles for the breaker).

3.2.2 Breaker Failure or Stuck Breaker Clearing Time

Breaker Failure clearing time is a mode of operation that considers the Protection System to be fully functional and will operate as designed and intended. However, it also considers that a breaker needed to isolate the fault failed to operate (remained closed or stuck). Planning engineers determine the critical clearing time for stuck breaker and/or breaker failure conditions. The protection engineer will account for this time when designing the breaker failure relaying protection. For example, the planning engineer might determine that the critical breaker failure clearing time is 12 cycles and this might result in the protection engineer setting the breaker failure timer at 8 cycles (2 cycles for relay time, 8 cycles for the breaker failure timer, and 2 cycles for breaker tripping). In some cases the protection engineer may determine that the critical clearing time cannot be achieved without compromising security of the Protection System. In such cases, the planning engineer must design the electric system around this constraint (e.g., installing two breakers in series to eliminate the

breaker failure contingency or constructing additional transmission elements to improve system performance, thereby increasing the critical clearing time).

3.2.3 Delayed Clearing Time

Delayed clearing time is a mode of operation that is a result of a Protection System failure to trip the breaker directly and/or initiate breaker failure logic. If a Protection System fails to clear the fault or initiate breaker failure, other relaying, locally or remote, will need to operate.

The protection engineer will need to closely examine all protection schemes locally and remotely to determine how Protection System failures will be mitigated. The worst case situation is that the Protection System failure did not trip or initiate breaker failure protection. However, certain failure modes could delay the initiation of breaker failure but not the transfer trip from the remote terminal. Only certain component failures are proposed for consideration and only these failures need to be studied and each component failure might provide different delayed clearing times. A Protection System failure might result in local or remote relays operating and, based on the particular substation, this could significantly extend clearing time.

3.2.4 Planning Standard Development

The revised planning standard presently under development⁷ provides for event categories (P1 through P7) based on single or multiple contingencies, and has differing performance requirements for steady-state and dynamic (stability) conditions. P5 is the category that considers Protection System failure during a fault. The proposed revision of the TPL standard uses two tables for the steady-state and stability performance requirements (paraphrased below from the draft TPL standard).

Table 1 - Steady-State Performance

1. Facility Ratings shall not be exceeded. Planned system adjustments are allowed to keep Facilities within the Facility Ratings, unless precluded in the Requirements, if such adjustments are executable within the time duration applicable to the Facility Ratings.
2. System steady state voltages and post-transient voltage deviation shall be within acceptable limits established by the Planning Coordinator (or Transmission Planner if more restrictive).

⁷ See the Standards portion of the NERC website at: <http://www.nerc.com/page.php?cid=2|247|290>

3. Voltage instability, cascading outages, and uncontrolled islanding shall not occur.
4. Consequential Load and consequential generation loss is allowed, unless precluded in the Requirements.
5. Simulate the removal of all elements that Protection Systems and controls are expected to disconnect for each event.
6. Simulate Normal Clearing times unless otherwise specified.

Table 2 - Stability Performance

1. The System shall remain stable.
2. Dynamic voltages shall be within acceptable limits established by the Planning Coordinator or Transmission Planner (if more restrictive)
3. Uncontrolled islanding and cascading outages shall not occur.
4. Simulate the removal of all elements that Protection Systems and controls are expected to disconnect for each event.
5. Simulate Normal Clearing times unless otherwise specified.

4. Proposed Protection System Reliability (Redundancy) Requirements

Protection System reliability must support the overall reliability requirements of the Bulk Electric System. The approach introduced in this paper establishes a Protection System Reliability (Redundancy) requirement in keeping with the tenets of Adequate Level of Reliability (ALR). Since the planning standards define the reliability performance to which the BES should be designed, those requirements can, in turn, be used to establish performance requirements for the reliability of Protection Systems. The approach introduced in this paper addresses the planning standard performance requirements that pertain to or rely on Protection System performance.

The approach introduced in this paper may appear to raise the design requirements of all Protection Systems; however, it only applies to those Protection Systems for which a failure causes the BES performance to violate one of the four requirements above. In many situations, the Protection Systems already employs sufficient redundancy and will not need to be upgraded or changed. In some other situations, where the Protection

Proposed Requirement

For system normal pre-fault system conditions, the Protection Systems must clear all single-line-to-ground and multi-phase faults in a clearing time such that:

1. System steady state voltages and post-transient voltage deviations shall be within acceptable limits established by the Planning Coordinator (or Transmission Planner if more restrictive).
2. Facility Ratings shall not be exceeded.
3. The system must remain stable.
4. The protection system must not trip system elements beyond those associated with the designed backup protection (local or remote), not including possible UFLS or UVLS operation.

NOTE: The proposed requirement is intended to mimic the performance requirements of the TPL standards. The TPL Standards should be the defining document for codifying the performance testing.

System is not redundant, backup or remote relaying may be sufficient with no upgrades or changes needed because Protection System failures do not result in violation of the BES performance requirements specified in the TPL standards.

The approach introduced in this paper *may* raise Protection System design requirements for some by calling for the examination of system performance in conjunction with specific levels of Protection System performance. It then requires mitigation for those conditions where Protection System component failures result in violation of the BES performance requirements.

4.1 Evaluating BES Performance

BES performance must meet the performance requirements specified in the TPL standards when a single component failure occurs within the Protection System. When a single component failure mode will prevent meeting the BES performance defined in the TPL standards, either the Protection System or the electric system design must be modified.

Providing Protection System redundancy is one method for ensuring that the BES meets the performance requirements of the TPL standards. Some examples are provided below to guide the application of the Protection System Reliability Standard.

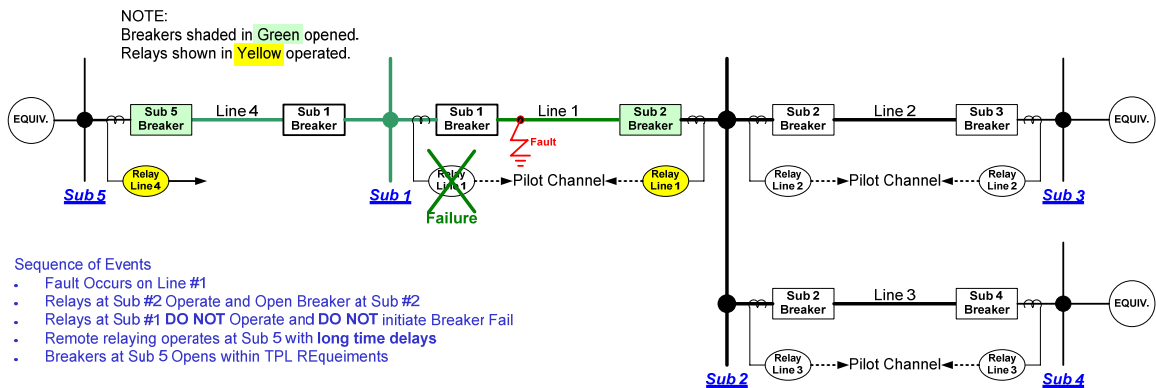

Figure 4–1 — Acceptable Delayed Clearing Example

1. Refer to Figure 4–1 — A power grid element (Line 1) requires a critical clearing time (for stability) of 50 cycles, and the element is protected by a single local pilot aided Protection System. Remote backup is available at Sub 3, Sub 4, and Sub 5 which will clear all faults on the element within 40 cycles. Therefore, a failure of the local protection on the element will not violate BES performance requirements (for voltage, facility ratings, or stability), and local redundant protection is not necessary; the remote backup protection provides the necessary reliability. Figure 4–1 illustrates what would happen for a non-redundant Protection System failure at Sub #1 for a fault on Line #1.
2. Refer to Figure 4–2 — A power grid element (Line 1) requires a critical clearing time of 20 cycles and the remote backup is capable of clearing faults for this element in 30 to 60 cycles. The local Protection System has various single points of failure that will require the remote backup schemes to clear the power grid element resulting in an unstable system. This is an infraction of the “System Must Remain Stable” performance requirements in the TPL standards. However, the failure must be tested for post transient voltage violations and facility rating violations also. The approach introduced in this paper would require the Protection System to be modified so that single component failures do not result in a violation of the BES performance requirements in the TPL standards. The Protection Engineer would then need to review the other proposed requirements (see Section 5) to make appropriate changes to the Protection System.

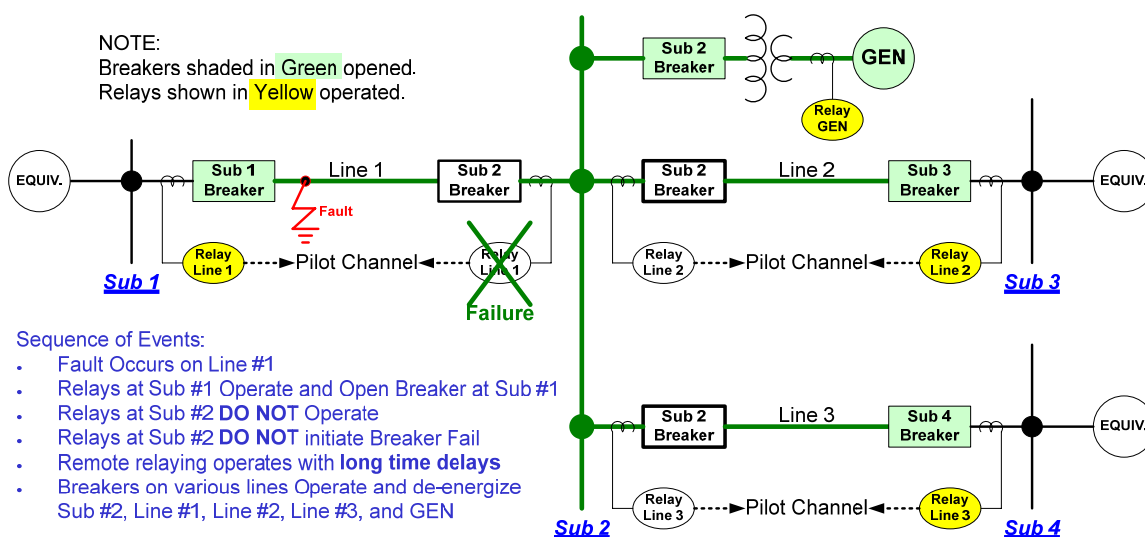

Figure 4–2 — Unacceptable Delayed Clearing Example

3. A transmission line at a generating plant requires the isolation of faults in a critical clearing time of 9 cycles (3 cycles plus breaker failure clearing time of 6 cycles). This example requires high-speed clearing (communication-aided relaying systems) to meet the 3-cycle clearing time and a breaker failure scheme capable of 6 cycle delay in order to meet the BES performance requirements of the TPL standards. In this case, no time-delayed backup system (either local or remote) can satisfy the 3-cycle requirement and violations could occur to facility ratings, stability, and post transient voltage violations at remote busses. The approach introduced in this paper would require redundant pilot relaying systems, (see Section 5), to assure that faults are detected and cleared within 9 cycles, even with a failed breaker or primary Protection System failure.
4. A line at a generating plant has a critical clearing time of 4 cycles, where breaker failure following an operation of a high-speed relaying system would result in system instability which is a violation of the BES performance requirements of the TPL standards. In this case, it may be necessary to add a redundant (series) breaker to meet the BES performance requirements in addition to other redundant protection as described in the third example above.

4.2 Development of a Testing Methodology to Determine the Need for Redundancy

The protection and planning engineers must work collaboratively to determine the need for Protection System redundancy. Portions of that process may be performed in parallel and may be iterative in nature.

Roles of the Protection and Planning Engineer

- The protection engineer’s role is to determine the performance of the Protection System through analysis of its failure modes and determine the operating times of the relaying.
- The planning engineer’s role is to determine if the clearing times provided by the protection engineer satisfy the system performance requirements through transmission planning studies.

From the general discussion in Section 4.1, the following testing methodology has been developed for assessing compliance with the BES performance requirements of the TPL standards. The order of these tests can be varied.

Methodology

- **Determine Redundancy of the Protection Systems** — Examine the Protection System for redundancy of the following components - AC Current Source, AC Voltage Source, Protective Relay, Communication Channel, DC Circuitry, Aux Trip Relay, Breaker Trip Coil, and Station DC Source. If the owner has determined that the listed components are redundant, no further action is needed except documentation.
- **Ascertain the Performance of the Protection Systems** — Based on the determined redundancy of the Protection System, determine the Protection System performance for a failure of each component listed above, or determine the worst case clearing time for Protection System failure.
- **Compare BES Performance with Required Performance** — Determine if the clearing times determined meet the BES

Worst Case Fault Test

The term ‘worst-case fault’ implies one of the four classical fault types – line to ground, line to line to ground, line to line, and three phase – with the location of the fault being placed where it results in the worst electric system performance. This fault may not be coincident with the location where a fault is hardest to detect or creates the longest clearing time for the local or remote backup protection system(s). The worst case fault typically must be identified through a collaborative effort between the planning and protection engineers.

To minimize the effort, conservative assumptions regarding fault clearing time may be made initially. When system performance evaluated in the planning study meets the TPL standards’ performance requirements no refinements to the initial assumptions are required. When system performance does not meet the TPL standards’ performance requirements, the initial assumptions must be refined and the system performance re-evaluated. This iterative process continues until system performance meets the TPL standards’ performance requirements with conservative assumptions or the worst fault location has been identified and evaluated using actual clearing times.

performance requirements listed in the TPL standards.

- **Mitigate all Violations** — Modify the electric system or Protection System design to eliminate any conditions identified for which the BES performance violates the requirements in the TPL standards.

These steps should be repeated whenever Protection Systems or electric systems are modified in some manner which changes the BES performance; such cases must be reviewed to assure that the BES still meets the performance requirements specified in the TPL standards.

4.2.1 Determine Redundancy of the Protection System

The protection engineer will need to examine the following components - AC Current Source, AC Voltage Source, Protective Relay, Communication Channel, DC Circuitry, Aux Trip Relay, Breaker Trip Coil, and Station DC Source. Each component should be examined to determine how the failure would impact operation of the Protection System.

Consider the two examples below. The first is an example of a non-redundant Protection System with possible solutions for component failures. The second is an example for a fully redundant Protection System.

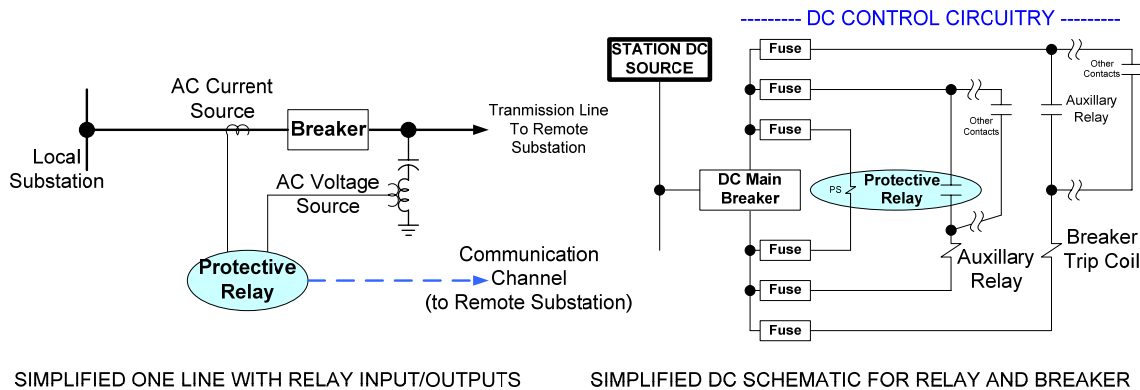

Figure 4-3 — Example 1 – Study of Protection System Reliability for Non-Redundant Systems

The following table is a non-exclusive list of possible impacts of dependability –based Protection System component failures or removal of components from service during a fault.

Table 4–3 — Example 1 – Study of Protection System Reliability for Non-Redundant Systems		
Component	Possible Impacts	Solutions
AC Current Source	Loss of AC current input to the protective relay usually disables the ability of the Protection System to sense faults which would result in delayed clearing times.	<ol style="list-style-type: none"> 1. Add redundant AC current input and an additional relay or 2. Verify that time delayed remote clearing does not violate the BES performance requirements of the TPL standards. standard)
AC Voltage Source	Loss of AC voltage input to the protective relay can disable the ability of the Protection System from sensing some faults. A high speed current-only relay will not be impacted by this failure and clearing times will depend on application. Worst case scenarios require delayed clearing times to be considered.	<ol style="list-style-type: none"> 1. Add redundant AC voltage input and an additional relay or 2. Verify that time delayed remote clearing does not violate the BES performance requirements of the TPL standards.
Protective Relay	Loss of protective relay means that faults can not be cleared locally which would result in delayed clearing times.	<ol style="list-style-type: none"> 1. Add redundant relay or 2. Verify that time-delayed clearing does not violate the BES performance requirements of the TPL standards.
Communication channel	Loss of the communication channel of the Protection System usually requires delayed clearing times for some faults on the transmission line (i.e. near the remote terminal). Worst case scenarios may require delayed clearing times be considered.	<ol style="list-style-type: none"> 1. Add redundant communication channel and possibly additional relay and communication equipment or 2. Verify that time delayed clearing does not violate the BES performance requirements of the TPL standards.
DC Circuitry	Loss of DC circuitry will depend on what components are disabled. If multiple components are impacted by the loss of a single circuit the entire Protection could be disabled. It could be possible that impact to the Protection System could be minimal. However, worst case scenarios may require remote delayed clearing times be considered.	<ol style="list-style-type: none"> 1. Add additional DC circuits and separate critical components or schemes or 2. Verify that time delayed remote clearing does not violate the BES performance requirements of the TPL standards.

Table 4-3 — Example 1 – Study of Protection System Reliability for Non-Redundant Systems

Component	Possible Impacts	Solutions
Auxiliary Tripping Relay	Loss of auxiliary tripping relays may impact the Protection System from providing a high speed trip, and may not prevent the protection System from initiating breaker failure protection. The result might be a clearing time that is longer than normal clearing times but less than delayed clearing times. Worst case scenarios may require delayed clearing times be considered if breaker failure is initiated by the auxiliary relay.	<ol style="list-style-type: none"> 1. Add additional auxiliary relays or 2. Alter the scheme to provide parallel tripping paths or 3. Verify that time delayed remote clearing does not violate the BES performance requirements of the TPL standards.
Breaker Trip Coil	Loss of the breaker trip coil will cause the breaker failure scheme to operate. If breaker failure logic does not include removal of all sources remote relaying may be needed to isolate the fault. Worst case scenarios may require delayed clearing times be considered.	<ol style="list-style-type: none"> 1. Add additional trip coil on a separate DC circuit or 2. Provide breaker fail and remote clearing for faults or 3. Verify that time delayed remote clearing does not violate the BES performance requirements of the TPL standards.
Station DC Source	Loss of the DC source prevents any relaying from operating at the station. Therefore, remote backup clearing times must be determined and compared against the critical clearing time for a fault at that station.	<ol style="list-style-type: none"> 1. Add continuous and reported monitoring 2. Add another DC source 3. Verify that time delayed remote clearing does not violate the BES performance requirements of the TPL standards.

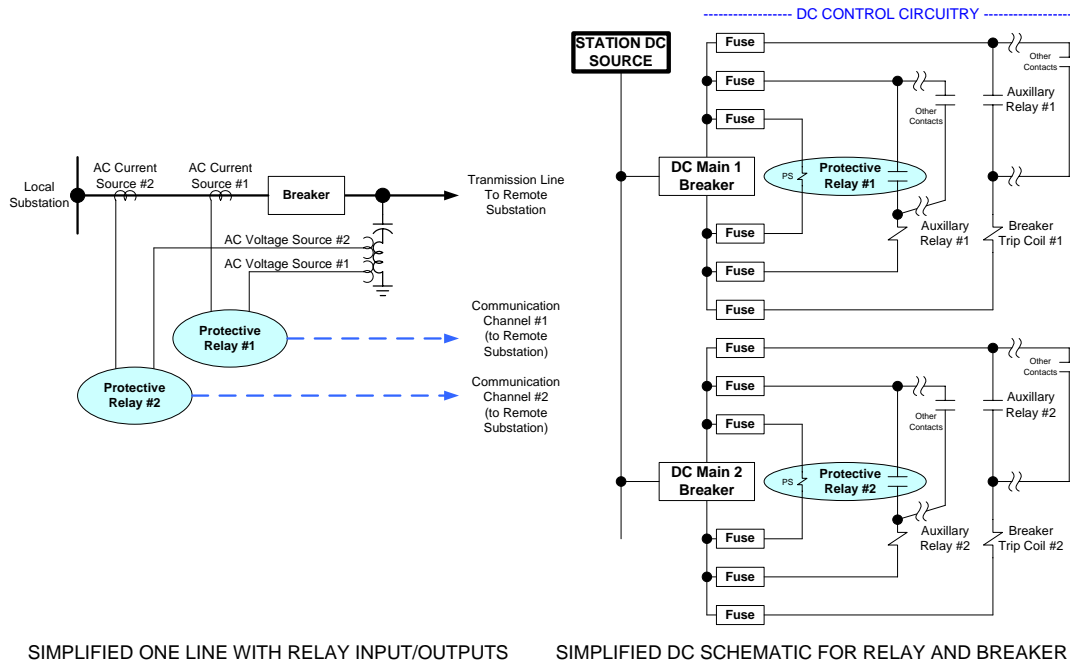

Figure 4-4 — Example 2 – Study of Protection System Reliability Redundancy for Redundant Systems

The following table is a non-exclusive list of possible impacts of dependability-based Protection System component failures or removal of components from service during a fault.

Table 4-4 — Example 2 – Study of Protection System Reliability Redundancy for Redundant Systems		
Component	Possible Impacts	Solution
AC Current Source	Fault clearing is not impacted by the loss of single AC current input. Redundant AC current sources provide functionally equivalent protection.	No immediate action needed. Repair or replacement must be made as soon as possible.
AC Voltage Source	Fault clearing is not impacted by the loss of single AC voltage input. Redundant AC voltage sources provide functionally equivalent protection.	No immediate action needed. Repair or replacement must be made as soon as possible.
Protective Relay	Fault clearing is not impacted by single relay failure. Redundant relay provides functionally equivalent protection.	No immediate action needed. Repair or replacement must be made as soon as possible.
Communication channel	Fault clearing is not impacted by single communication channel failure. Redundant communication channels provide functionally equivalent protection.	No immediate action needed. Repair or replacement must be made as soon as possible.
DC Circuitry	Fault clearing is not impacted by loss of a single DC circuit. Redundant DC circuits provide functionally equivalent protection.	No immediate action needed. Repair or replacement must be made as soon as possible.
Auxiliary Tripping Relay	Fault clearing is not impacted by single auxiliary relay failure. Redundant auxiliary relay provides functionally equivalent protection.	No immediate action needed. Repair or replacement must be made as soon as possible.
Breaker Trip Coil	Fault clearing is not impacted by loss of single trip coil. Redundant trip coil relay provides functionally equivalent protection.	No immediate action needed. Repair or replacement must be made as soon as possible.
Station DC Source	Failure of one of the redundant DC sources does not impact fault clearing times.	1. No immediate action needed. Repair or replacement must be made as soon as possible.
	Failure of the single, fully monitored DC source will impact fault clearing times.	2. Take appropriate operator action and emergency repairs must be made.

4.2.2 Determining Performance of the Protection System

The protection engineer can determine the performance of the Protection System by analyzing failure modes of the Protection System components and the resulting Protection System operating time. The clearing times should be categorized for the three performance categories: Normal Clearing Times, Breaker Failure Clearing Times, and Delayed Clearing Times. The

definition of these times are shown and discussed in Section 3 above. The protection engineer will document the operating times of the Protection Systems for all elements and then provide the planning engineer with these operating times to permit the planning engineer to determine BES performance based on case studies. Consider the example below.

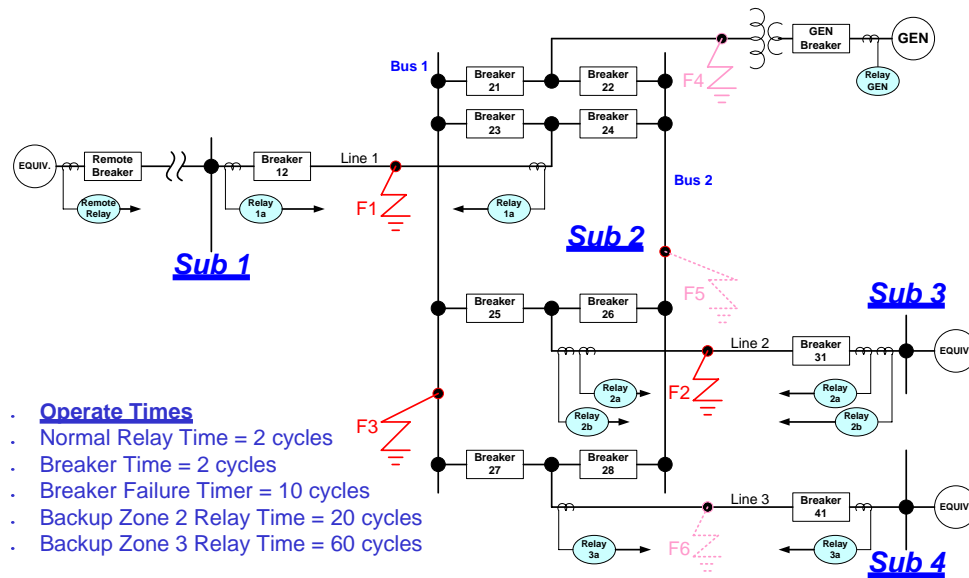

Figure 4–5 — Example 3 – Determining Protection Systems Performance

The following table is a non-exclusive list of possible clearing times of Protection Systems listed in the examples above.

Table 4–5 — Example 3 – Determining Protection Systems Performance (times are typical and will vary for each application)				
Fault Loc.	Normal Clearing Time	Breaker Failure Clearing Time	Does the Protection System have single points of failure?	Worst Case Clearing Time for Protection System Failure
F1	Sub 1			
	BKR 12 RLY 1a = 4 cycles	BRK 12 = 14 cycles	YES	Remote Bus Remote Relay = 22 cycles

Table 4-5 — Example 3 – Determining Protection Systems Performance (times are typical and will vary for each application)				
Fault Loc.	Normal Clearing Time	Breaker Failure Clearing Time	Does the Protection System have single points of failure?	Worst Case Clearing Time for Protection System Failure
F1 (cont.)	Sub 2			
	BKR 23&24 RLY 1a = 4 cycles	BKR 23 = 14 cycles BKR 24 = 14 cycles	YES	Sub 2 GEN RLY = 62 cycles Sub 3 RLY 2a = 62 cycles RLY 2b = 62 cycles Sub 4 RLY 3a = 62 cycles
F2	Sub 2			
	BKR 25&26 RLY 2a = 4 cycles RLY 2b = 4 cycles	BKR 25 = 14 cycles BRK 26 = 14 cycles	NO	Sub 2 BKR 25&26 RLY 2a or 2b = 4 cycles
	Sub 3			
	BKR 31 RLY 2a = 4 cycles RLY 2b = 4 cycles	BRK 31 = 14 cycles	NO	Sub 3 BKR 31 RLY 2a or 2b = 4 cycles
F3	Sub 2			
	BKR 21, 23, 25, & 27 = 4 cycles	BKR 21 = 14 cycles BKR 23 = 14 cycles BKR 25 = 14 cycles BKR 27 = 14 cycles	YES	Sub 1 RLY 1a = 62 cycles Sub 2 GEN RLY = 62 cycles Sub 3 RLY 2a or 2b = 62 cycles Sub 4 RLY 4a = 62 cycles

4.2.3 Compare BES Performance with Requirements of the TPL Standards

The BES performance must meet the performance expectations of the TPL standards for the specified level of Protection System performance. In some situations the planner has already

determined the critical clearing time for a fault. Fault clearing times in the range of 5 to 20 cycles will probably require full redundancy of the local Protection Systems. Fault clearing times that are longer than 20 cycles could provide the owner with the option of using remote backup protection to clear the fault. This over-tripping must also be examined to determine if there is any violation of the TPL standards' performance requirements. Prior to the 2005 Version 0 standards, planners tested the system for Normal and Breaker Failure clearing times and did not test for delayed clearing times because that was considered an extreme event.

Table 4.6 is a comparison of the relay performance clearing times and the acceptable system clearing times from the examples above. It should be noted that the critical clearing time is not met for the case with Protection System failure; an alternate designed would be required.

Table 4.6 — Acceptable Clearing Times (times are typical and will vary for each application)			
Line 1 – Fault F1	Actual Clearing Time	Critical Clearing Time	Violation of TPL- Standards
Normal Clearing Time	4 cycles	5 Cycles	None
Breaker Failure Clearing Time	14 cycles	15 Cycles	None,
Time Delayed Clearing Time- Protection System Failure	62 cycles	22 cycles	Stability

4.2.4 Mitigate All Violations of the TPL Standards

The planning engineer with support from the protection engineer can determine if the performance of the BES meets the performance requirements of the TPL standards for the specified level of Protection System performance. The performance of the Protection System is directly related to the failure of the various components. If a Protection System is fully redundant, no single protection component failure can impact the performance of the Protection Systems. However, if all components are not redundant, then some component failures can result in slower Protection System operation, potentially causing the performance of the BES to violate the TPL standards' performance requirements.

If a component failure prevents the Protection System from providing the required critical clearing time, then two options are available.

- Providing local redundancy can mitigate the Protection System component failures. This effectively makes the Protection System meet its designed operating time even when experiencing a single component failure. This could mean adding another AC Current

Source, AC Voltage Source, Protective Relay, Communication Channel, DC Circuitry, Aux Trip Relay, Breaker Trip Coil, or Station DC Source. Later sections will go into these descriptions in more detail.

- The protection engineer can assess the potential for improving the delayed clearing time from the remote backup protection and provide these revised values to the planner. The planning engineer can restudy this condition and determine if the BES performance meets the performance requirements of the TPL standards.

Planning engineers do not typically perform studies to identify delayed clearing times because studies can be very extensive for the many different elements, clearing times, and fault locations. However, the planning engineers do have the capability to study limiting conditions identified by the protection engineer. With the method specified in this section, the planning engineer will not have to run an infinite number of cases and can concentrate on the specific cases identified by the protection engineer.

An iterative process can occur as the protection engineer determines possible delayed clearing times and the electrical system components removed from service, and the planning engineer assesses the resulting BES performance for comparison with performance requirements of the TPL standards.

It will be necessary for the planning engineer and protection engineer to work collaboratively to identify those clearing times that need to be restudied or where the Protection System needs to be upgraded or modified to provide redundancy.

5. Protection System Components

Protection Systems are used to provide protection of all electric system elements. It is the primary job of a Protection engineer to apply these Protection Systems in a reliable manner to isolate all faults on the electric system. Protection Systems can be as simple as one relay that is applied to trip a breaker or very complicated and involve many functions and conditions and require equipment to be installed at multiple sites that use communication channels to transmit data. There are some basic components that make up most Protection Systems and these components must be applied in a reliable manner. The NERC Glossary of Terms lists the components of a Protection Systems as: Protective Relay, Associated Communication

System, voltage and current sensing devices, station DC supply, and DC control circuitry. The old planning standard also made reference to these components.

This section has four goals:

- Provide explanation of the selection of Protection System component failures
- Provide explanation of the review process for each of the Protection System component failures to determine if the approach introduced in this paper applies
- Provide examples demonstrating review of each Protection System component failure
- Provide some possible solutions that might fix a failure to comply to each of the Protection System component failures

It is important to understand that an identical protective system design installed across a power system may cause different

Protection Components Addressed

The legacy NERC Planning Standard III.A (1997) included a Measure specifying the need for separate AC current inputs and separately fused DC control systems if the loss of one of these elements would result in an event that did not meet system performance requirements. The need for separate AC current inputs implies the need for separate relays and the need for separately fused DC control systems implies the need for separate trip paths including auxiliary lockout or tripping relays, if used. The old Standard IIIA also included guides regarding the use of dual trip coils and communication systems. Recent and past Transmission System events with consequences that do not meet modern system performance requirements have occurred due to the failure of a single protection system component.

The list of components specified for performance tests in Section 5.0 of this technical paper were derived from the historical standards, experience from system events, and the collective judgment of protection engineers representing all the North American Reliability Regions. The list of components is not intended to provide complete redundancy of protection system components but rather provides a practical level of redundancy of protection system components to meet the performance requirements and expectations of the modern power system.

Proposed Requirement

Transmission Owners, Generation Owners, and Distribution Providers that own Protection Systems installed on the Bulk Electric System shall assure that a failure of the following components of Protection Systems will not prevent achieving the BES performance requirements of the TPL standards. (The components are described in this section)

results with respect to the BES performance requirements in the TPL standards and the BES performance required for specific single Protection System component failures - AC Current Source, AC Voltage Source, Protective Relay, Communication Channel, DC Circuitry, Aux Trip Relay, Breaker Trip Coil, and Station DC Source. Consider the following examples of a strong source system with highly-concentrated generation and load (Figure 5-1) and a weak source station where there are only two lines and there is high source impedance (Figure 5-2).

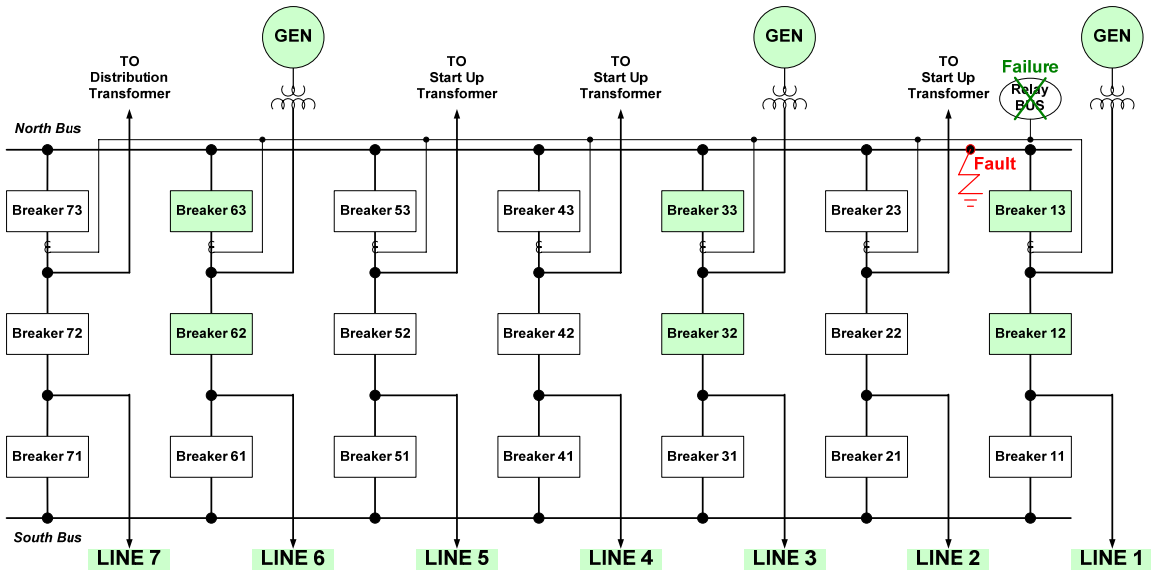

Figure 5-1 — Strong Source System One Line

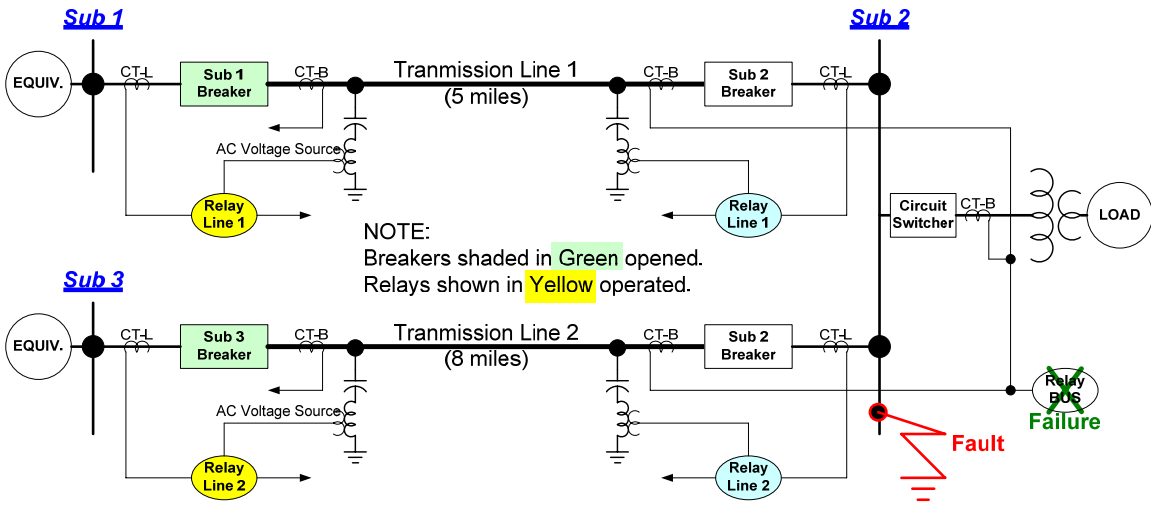

Figure 5-2 — Weak Source System One Line

Most transmission owners have standard applications that are applied for bus protection. The same identical protective scheme is used year after year for every bus protection application. The bus standard (for example) might be one high-impedance relay with one auxiliary lockout

device. The approach introduced in this paper requires that the applicability of this design be tested to insure that the TPL standards' performance requirements are met for each application of this bus protection scheme.

Example 1 – Refer to Figure 5–2, Assume that the first bus to be studied is at Sub 2. Sub 2 has two transmission lines and a distribution transformer connected to the bus via a circuit switcher. The protection engineer investigates the performance of the bus protection in clearing a fault on the bus for a failure of a CT, or CCVT, or protective relay, or communications channel, or DC control circuit, or auxiliary trip relay, or breaker trip coil, and DC source. The result is that there is no violation of the TPL standards' criteria for a fault on the bus and a Protection System component failure. The remote line relays associated with the two lines at Sub 1 and Sub 3 trip and lockout each line serving Sub 2 fast enough to meet all TPL standards' BES performance criteria.

Example 2 – Refer to Figure 5–1, A second bus study with an identical bus protection scheme having three generators and ten lines on a strong source substation revealed that the TPL standards' criteria was violated due to low voltage and facility ratings after remote tripping caused the lockout of the three units and seven lines.

The above example illustrates that the review process is both a detailed review of a protection scheme on an individual application basis to determine fault clearing times for each applicable failure mode, with a planning study for each protection review to determine if the power system response still meets the BES performance requirements of the TPL standards for the clearing time determined by the protection review.

Any applicable owners must assure that specific components (AC Current Source, AC Voltage Source, Protective Relay, Communication Channel, DC Circuitry, Aux Trip Relay, Breaker Trip Coil, and Station DC Source) failing one at a time must not violate the BES performance requirements of the TPL standards for a worst-case fault on the facility covered by the Protection System with the failed component. The performance or application of the breaker failure relaying is not considered in this study. The Planning standards have maintained that the breaker failure scheme need not be redundant. This is because breaker failure scheme is a backup to the breaker operation. Therefore, a simultaneous breaker failure and a breaker failure scheme failure are considered an extreme contingency.

5.1 AC Current Source

At least two isolated and separate AC current sources (referred to as CT inputs) for Protection Systems are required to meet the proposed requirement for CT

redundancy. Figure 5-3 shows a common arrangement that addresses the current measurement redundancy requirement. CTs are required to provide totally separate secondary AC current sources for each redundant Protection System. This is required so that a shorted, open, or otherwise failed CT circuit will not remove all protection elements requiring current. Figure 5-3 below shows the use of four CTs from a breaker with bushing CTs to separate the current measurement for the two Protection Systems for zones A & B.

Proposed Requirement

The failure or removal of any single **AC current source** and/or related input to the Protection System excluding the loss of multiple CT secondary windings.

Qualification: An event impacting multiple CT secondary windings (i.e., a failure of either a complete free-standing CT or an entire bushing with multiple CTs) would be detected and isolated by protection that is not dependent on these CTs.

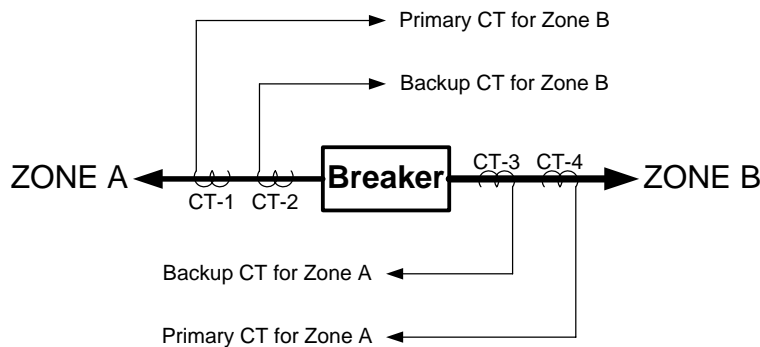

Figure 5-3 — Example of Redundant CTs

To assure that only one CT failure is addressed with each review, the proposed requirement would be qualified to indicate that an event impacting multiple CT secondary windings (i.e. – a failure of either a complete free-standing CT or an entire bushing with multiple CTs) would be detected and isolated by protection that is not dependent on these CTs. Good engineering practices should be followed in protection designs so that a failure of a complete free-standing CT Column, an entire bushing of a breaker or transformer with multiple CTs would cause a fault that would be detected and isolated by protection that is not dependent on these CTs. Some best practices include flashover protection for a free-standing CT column, and overlapping zones of protection for multiple CTs in adjacent or common wells.

The protective system failure of one CT circuit is a dependability type failure that makes all the relays associated with that CT inoperable. This situation can occur for a shorted or for an open CT circuit. The relays within this CT circuit or any auxiliary CT circuit connected to this main

CT must be considered as non-functioning. Each CT circuit must be considered to fail one CT a time. All the Protection Systems connected directly or through auxiliary CTs must be considered to be out of service. The worst-case fault in the protected zone must now be able to be cleared by either local or remote protection without violating the performance requirements in the TPL standards as introduced in this paper. The System Protection engineer will need to follow the methodology as outlined in Section 4.2 to assess the failure of each CT.

Example 1 – An old breaker with only one three-phase set of CTs with 5/5 auxiliary CTs is protecting a transmission line (Figure 5-4). The main CT and the auxiliary CT secondary circuits each contain a protective scheme for the transmission line. A failure of the main CT circuit can occur either by shorting the secondary at the breaker or at the point it enters the panel, or opening the CT circuit anywhere. The outcome of taking this one CT failure into account is that both transmission line relays will fail to operate for a fault on the protected line. The protection engineer must determine the clearing time for the worst-case fault on the protected transmission line. Typically a line end fault will result in the worst case clearing time. Note however, that a fault location with faster clearing may result in worse system performance.

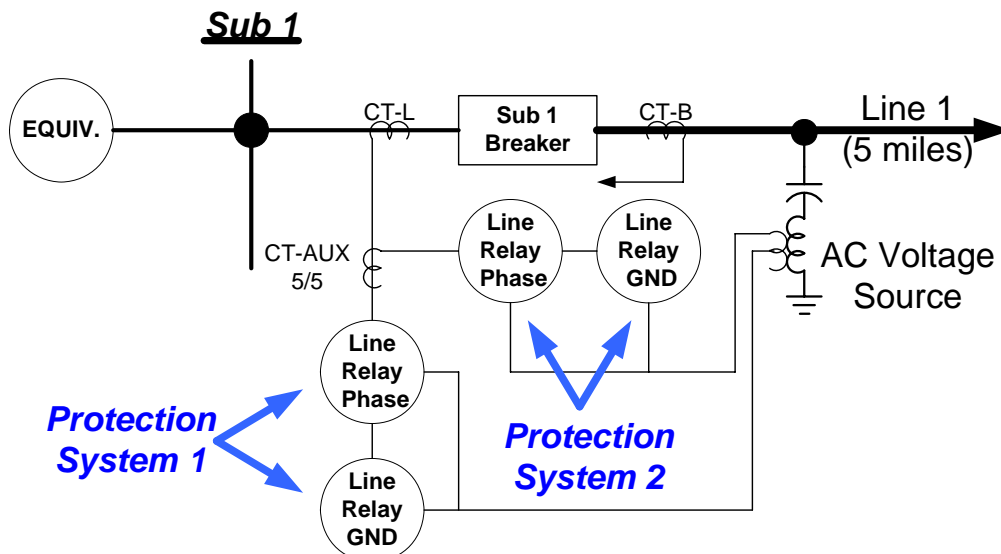

Figure 5-4 — Alternate CT Configuration with Single Point of Failure at the Main CT

Some items to be considered are:

- Are there other local relays at the substation that will clear the fault and what is the operating time of these relays?
- Are remote relays required to operate for this fault and what is the operating time of these relays?

- If the local substation has many lines then remote relays may not be able to sense a line end fault because the apparent impedance would be too great for the relay to detect.
- Sequential tripping of remote relays may be required to clear this fault.

A planning study must check to see if any violation of the BES performance requirements of the TPL standards occurs for the worst case fault on the line. If violations occur, the owner of this Protection System would need to find a solution for this example that will eliminate the violation caused by one CT circuit failure.

Possible solution for this example might be the addition of a new CT into the existing breaker, bushing slipover CTs, stand alone CT columns, or the replacement of the breaker with a breaker having additional CTs. Each of these solutions requires that a CT be provided with appropriate ratio, class, and thermal factor for the transmission line application.

Protective relays at the remote terminals can be adjusted or replaced so that they provide sufficient backup clearing times to meet the BES performance requirements of the TPL standards. If the relay reach is increased, the protection engineer should examine the relaying at the remote sites to make sure that they meet the loadability requirements of PRC-023-1. The last solution was presented to demonstrate that there are possible solutions other than the straightforward CT additions.

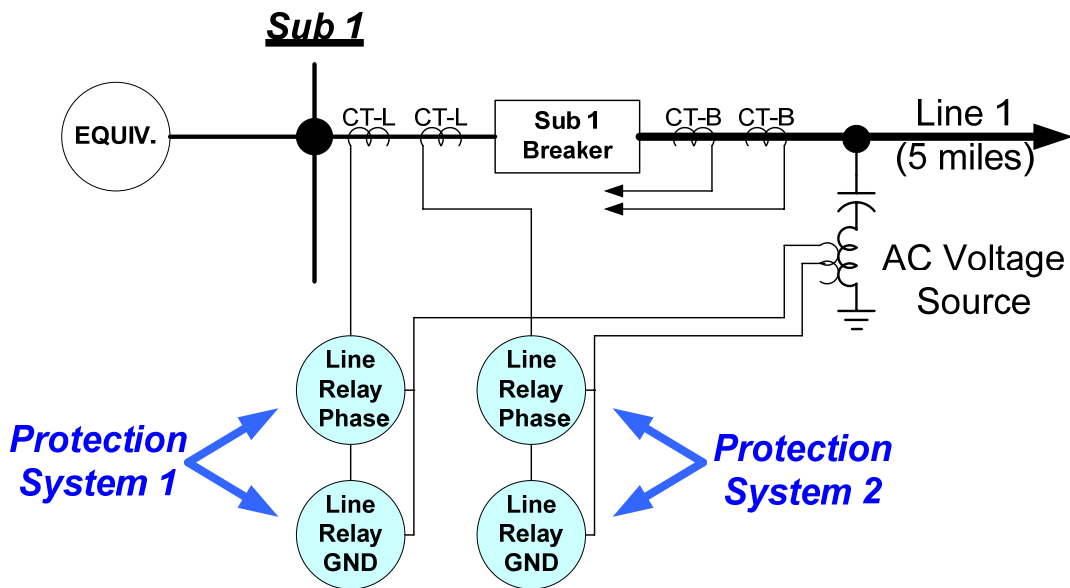

Figure 5–5 — Redundant CT Configuration

Example 2 – A transmission line is protected by a breaker with two dedicated CTs available (Figure 5–5) for line Protection Systems having similar functioning relays connected to each CT. Assume for this example that each relay can provide protection of the transmission line and does

not violate the BES requirements of the TPL standards for a normal operation to clear a fault. Failing one CT at a time will result in the same clearing times as a normal operation because the remaining relay will not be impacted. Thus the approach introduced in this paper would not result in any violation of its BES performance requirements in the TPL standards and the owner of this Protection System meets the requirement for CT redundancy.

5.2 AC Voltage Source

At least two separate secondary windings supplying voltages for Protection Systems are required to meet the proposed requirement for AC voltage source redundancy when such voltage sources are required to satisfy the BES performance required in the TPL standards. This is required so that a shorted, open, or otherwise

Proposed Requirement

The failure or removal of any single secondary **AC voltage source** and/or related input to the Protection System when such voltage inputs are needed excluding the complete loss of an entire CCVT, VT, or similar device with multiple secondary windings.

Qualification: Separate secondary windings of a single CCVT, etc, can be used to satisfy this requirement. An event impacting multiple AC voltage sources (i.e. – a failure of an entire CCVT, VT, or similar element) will be detected and isolated by other protection that is not dependent on these voltages.

failed voltage circuit will not remove all protection elements requiring voltage. This level of redundancy is required only if the BES performance cannot meet the performance requirements of the TPL standards when AC voltage is unavailable to all Protection Systems applied to the protected zone.

Figure 5–6 below shows a potential device with two independent secondary voltage windings. The two secondary voltage sources are utilized independently by the two protective relay systems meeting the proposed requirement. Both Protection Systems in Figure 5–6 require voltage measurements to perform their protective functions and must have separate secondary sources as illustrated. The proposed requirement eliminates the possibility of a single point of failure in the Protection Systems requiring voltage measurements to perform their intended function. The proposed requirement **does not** prevent loss of voltage measurement to the protective devices in the event of the failure of the main CCVT, VT, or similar device. Loss of AC potential to relaying can cause the relaying to be more sensitive to remote faults and could cause the relay system to over trip.

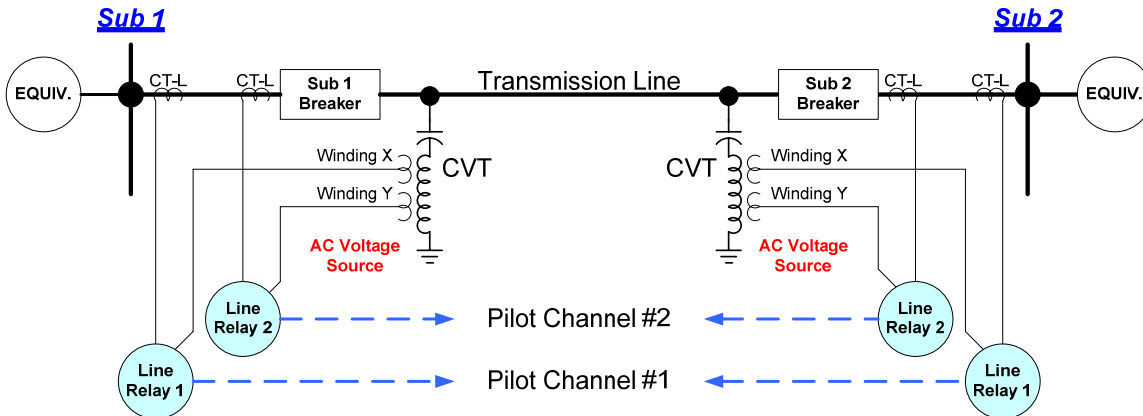

Figure 5–6 — AC Voltage Inputs

To minimize the effects of a failed AC voltage source, the redundant Protection System can use protective devices that do not rely on AC voltage measurements to respond to system disturbances. Substituting a Pilot Wire or Current Differential protective scheme for the relay 2 in Figure 5-6 would also be a method that would meet the proposed requirement without requiring the use of the second potential secondary. To assure that only one VT winding failure is addressed with each review, the proposed requirement would be qualified to indicate that separate secondary windings of a single CCVT, etc. can be used to satisfy this requirement.

The protective system failure of one CCVT, VT, or similar device, creates a failure for Protection Systems depending on Loss of Potential feature chosen. The proposed requirement is based on the fact that potential source failures result in an increased chance of tripping without fault or over-tripping during a fault in the area; not failure to trip. This is an additional reason why the proposed requirement does not require multiple three-phase sets of CCVTs, VTs, or similar devices. As discussed further below, the consequence of an over-trip will need to be reviewed to ensure it does not cause violation of any BES performance requirements of the TPL standards.

Each secondary voltage source failure should be analyzed to determine the Protection System performance for the fault in the protected zone that results in the worst BES performance. The proposed requirement must be met unless the Protection System with the failed potential source can still perform its intended protection function, or the local or remote Protection System responding to the above failure has a clearing time that results in meeting all the BES performance requirements of the TPL standards. If the relay will over-trip then the Protection System performance should be analyzed for faults within the over-trip zone that results in the worst electrical system performance to determine whether all the BES performance requirements of the TPL standards will be met for the over-trip case.

Thus, one potential secondary circuit can be sufficient for a given zone of protection when both relays for this zone require potential inputs, provided that all BES performance requirements of the TPL standards will be met for all faults within or external to the protected zone when the single AC voltage source fails.

The use of the Loss of Potential (LOP) feature of some relaying schemes can be utilized to change to an alternate setting. If this alternate setting group will result in BES performance that meets the requirements of the TPL standards then no further actions are required. This feature can have both phase and ground non-directional overcurrent elements activate for the LOP condition and operate at a definite time. The time might be picked to allow any high-speed systems time to clear a fault in adjacent protection zones while operating much faster than remote zone two timer settings. A best practice is to utilize the LOP feature to provide an alarm to a 24/7 manned dispatch center which can initiate an investigation of the problem.

Example 1 – A transmission line has two Protection Systems and has one set of three-phase potential devices with two secondary windings as separate sources. The failure of one secondary potential source does not impact the operation of the overall protection of the line. Both Protection Systems provide the same performance, so the failure of either secondary potential source does not increase the clearing times.

Example 2 – The same Protection Systems as in the case above, but with only one secondary winding connected to both relays. For this example, failure of the secondary potential source removes both relays from normal operation. In this case it is required to determine whether all BES performance requirements of the TPL standards will be met for all faults within or external to the protected zone when the single AC voltage source fails. In this example the primary microprocessor relay has been set to trip on special non-directional current elements that are activated for loss of potential. The microprocessor relay is set to ensure tripping for all faults on the protected line, which results in over-tripping for faults external to the protected line for loss of potential. A planning study must determine that the BES performance meets all performance requirements of the TPL standards when tripping for faults on the protected line is initiated by the Loss of Potential feature on the primary relay, and when the Loss of Potential function on the primary system over-trips for faults external to the protected line. Note that LOP elements are not required to meet relay loadability requirements of standard PRC-023-1.

These examples demonstrate two of the ways that the line Protection System can be designed to meet the requirements introduced in this paper.

5.3 Protective Relay

Each element of the electric system must be protected by at least 2 relays. These relays can be located at the same terminal or may be located at different terminals, but

Proposed Requirement

The failure or removal of any single **protective relay** that is used to measure electrical quantities, sense an abnormal condition such as a fault, and respond to the abnormal condition.

both relays must provide the same performance and clearing times for faults on the element. The protection engineer must examine the failure or the removal of one of these protective relays at a time to determine if there is a violation of BES performance required by the TPL standards for the worst case fault condition. The review process requires the removal of each local protective relay one at a time for each protective zone to determine the clearing time provided by either other local or remote backup protective relay schemes for the worst-case fault in that protection zone. The second part of the review process requires a planning study be completed to determine if any the TPL standards' performance requirement violations occur for the clearing time determined from the worst-case fault in the protection zone with the failed relay.

Example – Refer to the general examples in the opening paragraphs of section 5.0 (figures 5-1 and 5-2). These two examples described a bus Protection System that consisted of one high-impedance relay and one lockout auxiliary device that were identical for two very different applications. Both cases utilized remote backup Protection Systems to clear the worst-case bus fault. Example 1 concludes that remote impedance relaying has a sufficient clearing time, trips Line 1 and line 2 and will not cause any the TPL standards' performance requirement violations. Example 2 from Section 5 concludes that the number of system elements lost or the time required to clear this fault causes BES performance requirement violations of the TPL standards to occur with respect to facility ratings, thermal or voltage. These examples demonstrate clearly how a protective relay failure can impact the BES and why it is important to apply appropriate redundancy to Protection Systems to minimize the impact of a Protection System component failure.

A possible solution to overcome the violations in Example 2 could be the addition of a second bus protective scheme that eliminates the dependence on remote backup for a protective relay failure. The additional relay must be installed in such a manner as to not cause it to fail simultaneously due to any of the other seven component failure modes in the proposed requirements.

5.4 Communication Channel

The communication systems for each protective relay must remain independent from each other as they are transmitted to the opposite terminal when the proposed requirement is applicable.

The proposed redundancy

requirement for independent or separately dependable communications is required when the Protection System cannot meet the BES performance requirements of the TPL standards without utilizing communication-aided protection. Refer to Section 4.1 case # 3 for an example. This requirement acknowledges that failure-tolerant communications may be achieved either by designing the application with no common-modes of failure or by designing the application such that common-modes of failure will not prevent the Protection Systems from clearing faults to satisfy the BES performance requirements of the TPL standards in the planning review for the protection zone under review.

Fully independent communication channels are the hardest elements to provide for redundancy when pilot channels are required to meet the BES performance requirements of the TPL standards. It is recognized that some types of dual communications schemes have common modes of failure that are rare in occurrence; those limitations are generally accepted. The design of the overall Protection System must take such limitations into account even when communications channels are “redundant.” For instance, if the same communication technologies are used, it is recommended that the relay schemes selected have minimal channel-dependency in order to trip successfully for fault conditions. Many other considerations, such as the performance of the communications during faults and the impact of weather conditions on the performance of the communications, need to be considered in the design of the Protection System.

Some acceptable communication schemes are:

- Two power line carrier systems coupled to multiple phases of the line.
- Two microwave systems and paths with multiple antennas on a common tower.
- Two fiber paths between terminals (two fibers in the same cable are not acceptable)
- Two separate communication systems of different technologies and equipment (e.g., fiber optic and digital microwave).

Proposed Requirement

The failure or removal of any single **communication channel** and/or any single piece of related communications equipment, as listed below, used for the Protection Systems when such communication between protective relays is needed to satisfy BES performance required in the TPL standards.

- Communications functions for communications-aided protection functions (i.e. pilot relaying systems).
- Communications functions for communications-directed protection functions (i.e. direct transfer trip).

Figure 5–7 illustrates two independent communication aided Protection Systems with direct transfer trip schemes. The figure indicates that the two schemes are Directional Comparison Blocking (DCB) and Permissive Overreaching Transfer Trip (POTT), but there are many other types of high-speed communication aided protective schemes available. A communications aided system is provided for each Protection System and includes direct transfer trip for breaker failure. The communication schemes need to be independently designed and implemented between terminals in order to meet the proposed redundancy requirement.

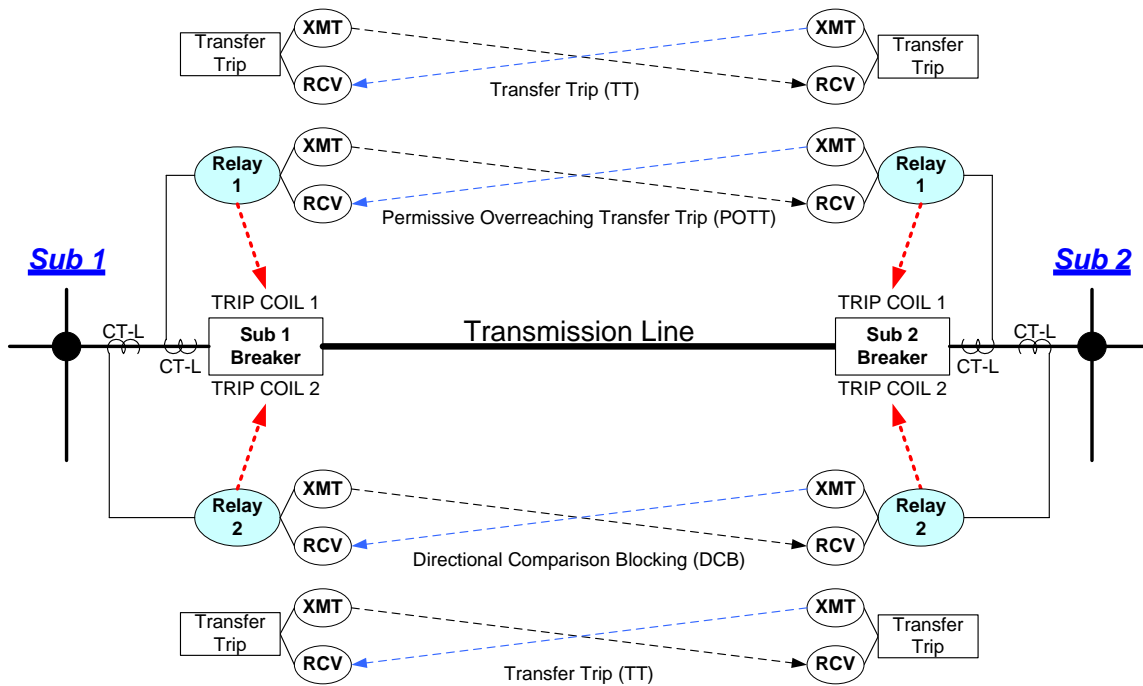

Figure 5–7 — Communication System

Dual pilot relaying may not be necessary to meet BES system performance requirements of the TPL standards. Non-pilot relaying may be able to satisfy the BES performance requirements of the TPL standards for some applications when the critical clearing times increase as the fault is moved further from the local terminal. This may require special planning studies that might result in eliminating the need for dual pilot relaying. These studies and assessments must be done on a periodic basis or whenever system changes are made that might alter the ability of non-pilot relaying to satisfy performance requirements. The Protection System communication only needs to be redundant for power system responses that require high-speed clearing for the worst-case fault in order to meet the BES performance requirements of the TPL standards.

The review process requires failing the communication channel to determine if the critical clearing time for the worst-case fault within the zone requires dual pilot relay systems in order to meet the BES performance requirements of the TPL standards. A planning study must be

performed to determine the critical clearing time for meeting all the BES performance requirements of the TPL standards. When the clearing time required to meet BES performance requirements of the TPL standards cannot be achieved without communication-aided protection, then the need for independent and redundant communication channels is required.

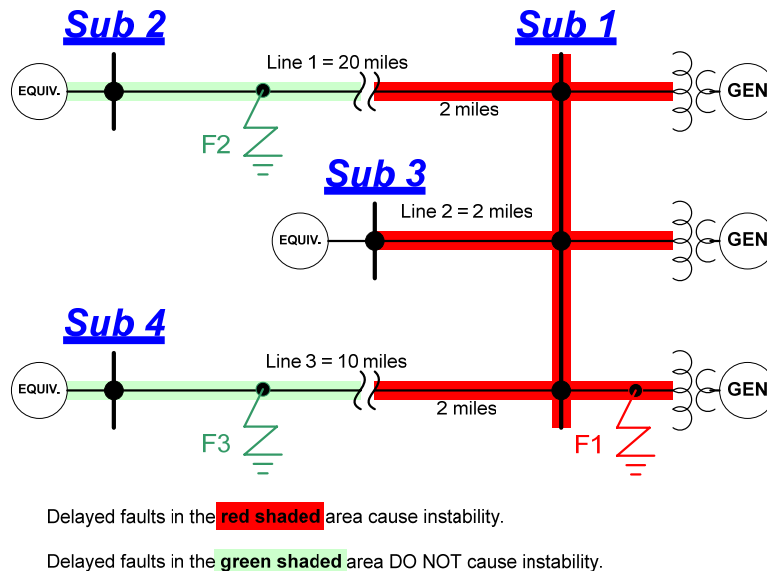

Figure 5–8 — Faults Near a Generating Station

Example 1 – Figure 5–8 illustrates 4 substations of a larger electric system. Sub #1 has three large generating units and a critical clearing time of 8 cycles for stability for faults close to the generators. Faults in the red area, as shown on the drawing, will cause instability if not isolated within 8 cycles. Faults in the green area, as shown on the drawing, will not cause instability for delayed clearing times up to 25 cycles. The line Protection Systems and the breaker failure system have been designed for each transmission line in order to meet the critical clearing time for stability of these three generators. Dual high-speed pilot Protection Systems were utilized on Line #2 to meet the 8 cycle critical clearing time for both pilot and direct transfer trip for breaker failure. One communication medium was power line carrier and the other microwave. Line #1 and Line #3 have only one high-speed pilot Protection System and one step distance impedance relay. The step distance impedance relay must provide high speed clearing for all faults on the line within the red shaded area. Due to the short critical clearing time it was necessary to design two independent high-speed relaying schemes for line #2 to meet the BES performance requirements of the TPL standards.

Example 2 – If the power system can meet the BES performance requirements of the TPL standards while experiencing an over trip for a communication failure, then it would be possible to utilize dual on/off directional comparison blocking schemes (DCB) or equivalent. The

sensing relays for the DCB schemes or equivalent must be set to cover for pilot and direct transfer trip channel failure without causing any ‘Loadability’ requirement violations.

5.5 DC Control Circuitry

The proposed requirement would require mitigation for a failure of the DC control circuitry that is used by the Protection Systems.

Proposed Requirement

The failure or removal of any single element of the **DC control circuitry** that is used for the Protection System.

The DC control circuitry does not include the station DC supply (covered in Section 5.8) or the breaker trip coils (covered in Section 5.7) but is considered to be all the DC circuits used by the Protection System to trip a breaker. This section includes any DC distribution panels, fuses, and breakers. This requires DC control circuits to be independently protected and coordinated, for each redundant Protection System required. This requirement may precipitate the need for multiple trip coils (See Section 5.7).

If the DC control circuitry for each Protection System is not properly designed and implemented, all the protection for a power system element could be removed by the loss of one DC breaker or fuse. Each DC control circuit must be reviewed to ensure that this does not occur if it results in a violation of the BES performance requirements of the TPL standards. The object is to prevent the outage of all the necessary protection for any one failure of the DC control circuits except for the non-redundant battery and charger or trip coils which are covered in later sections.

The DC control circuitry has many failure modes. A short in the DC control circuit requires the operation of a protective device (DC breaker or fuse) to remove the fault resulting in the loss of all the Protection System components on the circuit simultaneously. An open in the DC control circuit removes all Protection System components associated with that circuit from service simultaneously. The DC control circuit for each Protection System must be reviewed to determine how the failure of each DC control circuit impacts the protection for each Element. In every failure mode the Protection Systems must meet the BES performance requirements of the TPL standards.

Figure 5–9 demonstrates three DC circuit methods. Example 1 on the left has only one main circuit with coordinated sub-circuits. This style control circuit does not meet the DC redundancy control circuit requirements because the operation of one DC breaker can remove all Protection Systems. Example 2 has two main circuits and coordinated sub-circuits and meets the proposed DC redundancy control circuit requirement when paired Protection Systems are connected to different breakers. Example 3 also meets the proposed requirement and is an example of a fully

redundant and separate DC Supply and DC control circuit system when paired Protection Systems are connected to different DC panels and breakers.

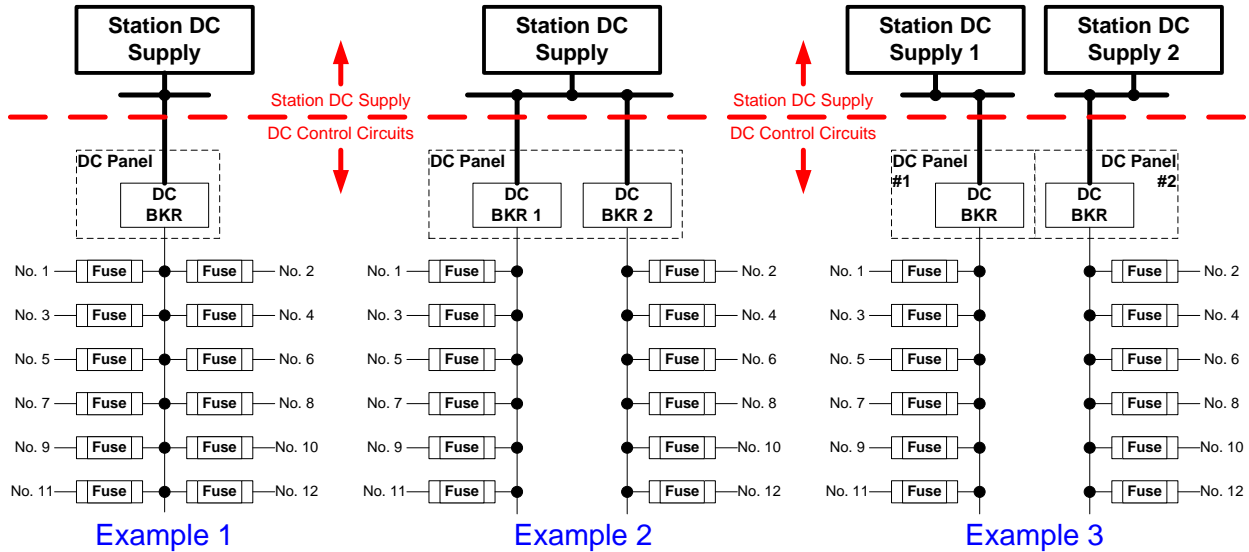

Figure 5-9 — Station DC Supply and DC Control Circuits Boundary

Figure 5-10 depicts a Protection System that employs redundant relays, AC supply and dual communication channels. The DC control circuitry is run from the DC Main that consists of a single 60-ampere breaker connected to fuse panel. Individual fuses that coordinate with the 60-ampere breaker are utilized to separate and isolate individual protective schemes. The opening of the 60-ampere breaker will remove all the local protection (both relays) that is protecting the transmission line. The loss of the Protection Systems on this transmission line must be tested based on Section 4 and the resulting BES performance must meet the BES performance requirements of the TPL standards for the worst-case fault within the zone or zones of protection that are removed from service by opening the 60-ampere breaker.

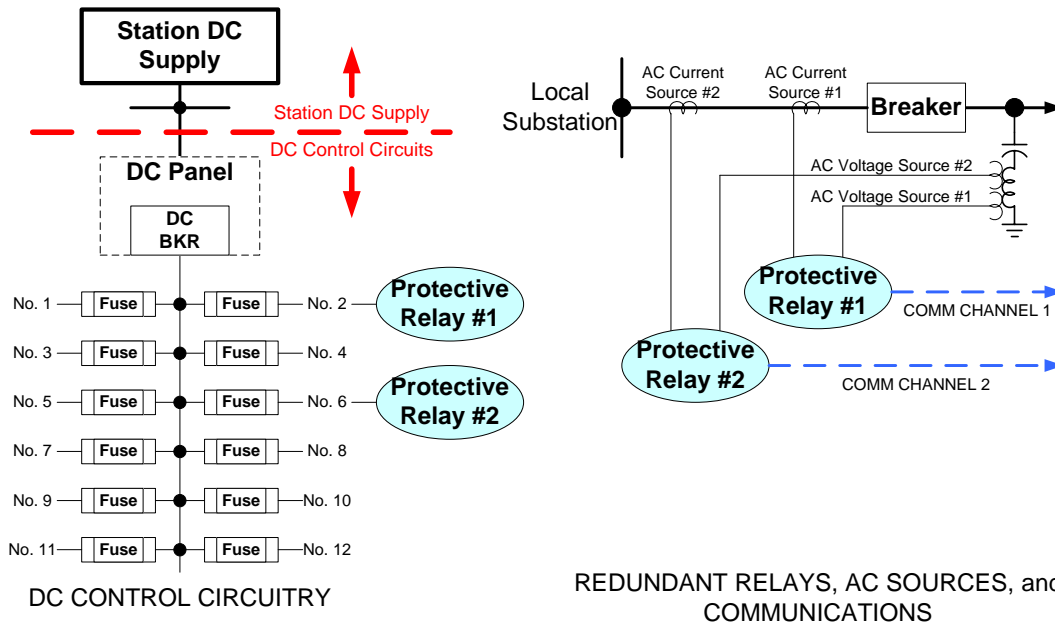

Figure 5-10 — Non-Redundant DC Control Circuits

If the example above caused a BES performance requirement violation of the TPL standards for the opening of the 60 amp breaker then it might be fixed by subdividing the 60-ampere circuit into two 60-ampere breakers fed from the Station DC supply. Each protective relay and associated DC control circuit should be separated with each one supplied from a different breaker so that the opening of a single breaker does not remove both Protection Systems.

5.6 Auxiliary Relay

The auxiliary tripping relay is typically used to expand available contacts or provide common interface between dissimilar

Proposed Requirement

The failure or removal of any single **auxiliary relay** that is used for any of the above functions.

Protection Systems. This requirement focuses on the auxiliary tripping device to determine if its failure will violate the BES performance requirements of the TPL standards. The failure of auxiliary tripping relays and lockout relays in particular can contribute to prolonging abnormal power system condition. All auxiliary devices that impact the clearing time of faults on the power system must be checked to determine if their failure, one at a time, will cause any BES performance violations of the TPL standards.

Example – The examples described in the opening paragraphs of Section 5 consisted of one high-impedance protective relay and one lockout auxiliary device protecting a bus for a strong

source system (refer to figure 5–1). In section 5.3 it was shown that a failure of the single bus relay caused a violation of the TPL standards. The bus Protection System also had only one auxiliary lockout relay. The failure of the auxiliary device or the protective relay for these examples will cause the same violations of the TPL standards and the loss of the same system elements. The solution is to add a second auxiliary relay and second protective relay and design the Protection System so that a loss of one auxiliary relay or one protective relay does not cause violations of the TPL standards. An additional solution would be to initiate breaker fail protection from all the protective relaying that operates the auxiliary relay. For this solution, the breaker failure time would need to meet the performance requirements of the TPL standards.

A related issue is the failure of an auxiliary device that provides both a trip and breaker failure initiate. Assessment of such a design must take into account that the failure of such a device will result in losing both the trip and breaker failure protection functions simultaneously. If that system cannot meet BES performance requirements of the TPL standards, the design must be changed to ensure that the failure of the auxiliary relay does not prevent tripping and breaker fail initiation.

5.7 Breaker Trip Coil

The relay systems and each trip coil must be operated from independent DC control circuits to prevent a single point of failure. Refer to Figures 5–9 and 5–10 in Section 5.5 for the DC control circuit review for the DC redundancy requirements.

Proposed Requirement

The failure or removal of any single **breaker trip coil** for any breaker operated by the Protection System.

This requirement focuses attention on the trip coil to make certain that its failure does not cause any violation(s) of the BES performance requirements of the TPL standards. The breaker trip coil provides the action that operates the breaker to clear the fault. Therefore, its failure to operate will cause breaker failure or delayed clearing times.

The Protection System outputs must be studied to determine if trips are issued to independent trip coils. If the Protection Systems issuing trip signals are duplicated to two independently operated trip coils then for this case the review is complete for the failure of one independent trip coil at a time because tripping will still be completed through the second path with exactly the same clearing time. However, if this is not the case then the clearing time for the worst-case fault in the zone(s) with the failed trip coil must be determined. A planning assessment must be made to determine if failure of the trip coil results in a violation of the BES performance requirements of the TPL standards.

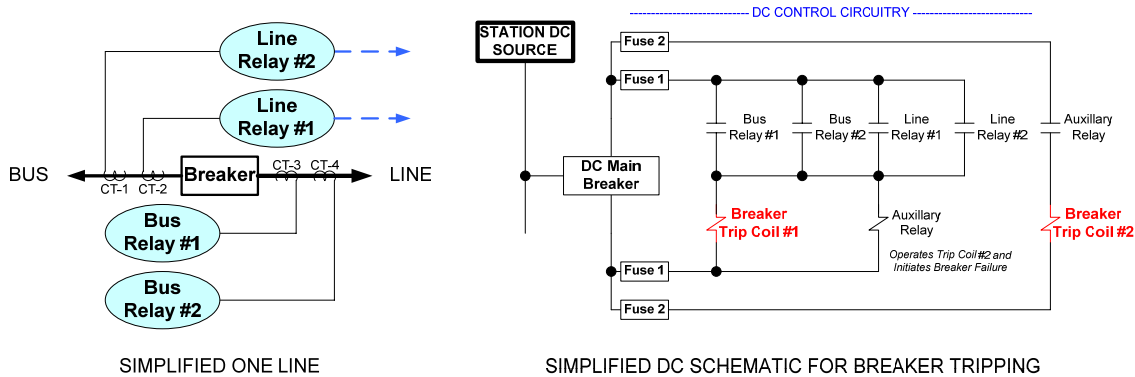

Figure 5-11 — Trip Coil Development

Example – Figure 5-11 depicts a breaker having two trip coils. The breaker is in the middle of overlapping zones of protection with 4 relay systems. Two of the systems are from line protection and two are from bus protection. The four relays will operate trip coil #1 and an auxiliary relay. The auxiliary relay operates trip coil #2 and provides breaker failure initiation (BFI). Since the two trip coils are not completely independently operated by all protection, a single failure can disable both trip coils and prevent BFI. This scheme has several single points of failure: the loss of Fuse 1, the tripping of the DC Main Breaker. Both of these failures will prevent tripping and breaker failure initiation. The procedure requires that the clearing time be determined for the worst-case fault in the line or bus zones, and a planning study completed to determine if the clearing time for the failure of the trip coils will result in meeting all the BES performance requirements of the TPL standards.

In the example above if a violation of the TPL standards did occur, one approach would be to make the two trip coils independent from one another. A properly designed breaker failure scheme meeting all the requirements of the TPL standards and the proposed Protection System redundancy requirements could be used to overcome a breaker with only one trip coil or two trip coils operated in parallel.

5.8 DC Source

The station DC supply for tripping has traditionally been and still is a DC system consisting of a charger & battery. In order for this reliability

Proposed Requirement

The failure or removal of any single station battery, or single charger, or other single **DC source**, where such losses are not centrally monitored for low voltage and battery open.

proposed requirement to accommodate other new technologies the proposed requirement will include the wording “other single DC source”. The Station DC Source will cover the charger,

station battery, or other DC source that is used for powering the Protection Systems and used for tripping.

The Station DC supply is usually designed to withstand short outages to the charging system or external supply. A charger failure results in the battery not being charged but it is assumed that the batteries have been fully charged prior to the loss of the charger. A properly sized battery should have the ability to provide the DC tripping and loading requirements of the substation design criteria. If neither DC source is battery based, at least one DC source must be able to provide the DC tripping and loading requirements of the substation equivalent to a battery.

However, there are failure modes of the DC system that can result in the immediate loss of all DC supply. Refer to figure 5–12 that depicts a typical station DC supply consisting of an AC supply, battery charger and batteries. The single station DC supply must be monitored continuously for the loss of critical components that would prevent total loss of the station DC supply. This monitoring must include battery open and low voltage and must be reported to a manned 24/7 operations desk for immediate response. A single battery & charger system must be monitored continuously for each of these failure modes. The use of monitoring significantly reduces the risk of having a complete battery failure at the time of a fault. It is important that the protection engineer understand the performance of the remote Protection Systems for the complete loss of the local station DC supply. Appendix A provides a discussion that illustrates the complete loss of station DC supply.

The protection engineer must determine if there is a violation of the BES performance requirements of the TPL standards for the loss of a single charger or single battery failure. If the failure of the single charger or single battery does not result in clearing times that violate the BES performance requirements of the TPL standards for the worst case fault condition, then no action is required. A substation that has two separate and redundant station DC sources meets this scenario. For every station DC supply, two tests must be considered to determine if the proposed requirement is met for a single source DC supply. The first test is to check and determine that the single station DC supply is monitored for charger failure, low voltage and open battery condition. The second test is to determine if the appropriate continuous alarming of the station DC supply exists at this station. The alarm must also be communicated to the manned 24/7 operation center.

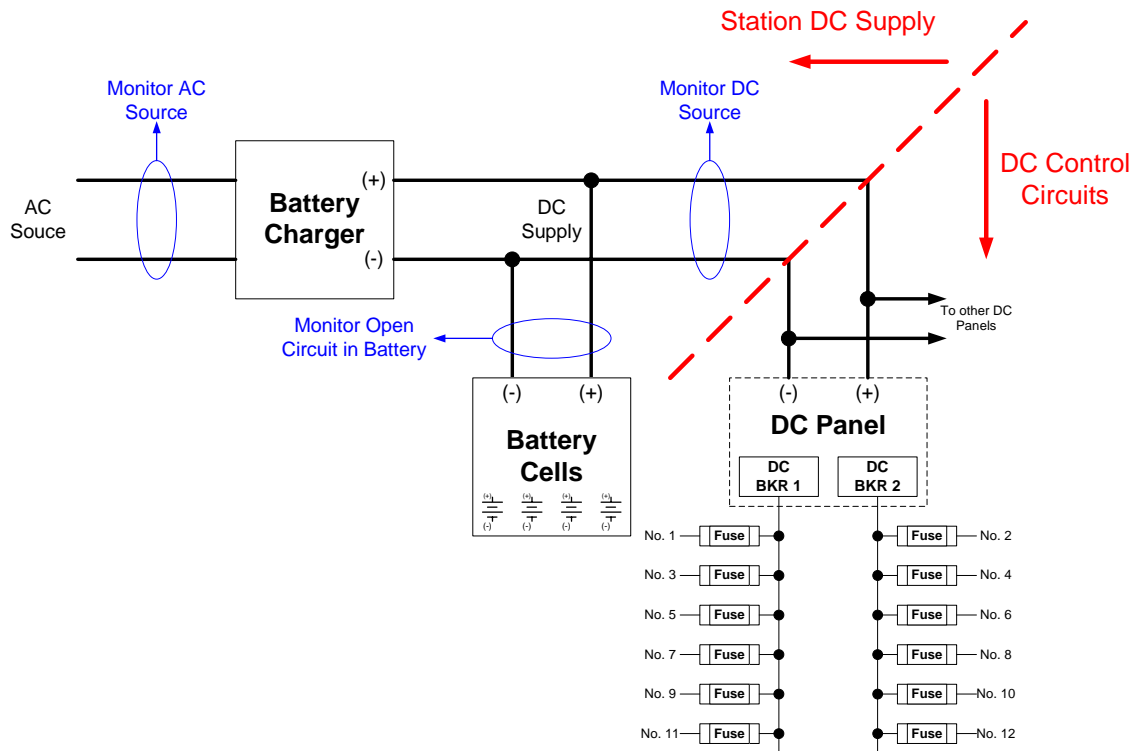

Figure 5–12 — Station DC Supply and Monitoring

Consider this example: Figure 5–1 above depicts a large strong source substation with many lines, generation and load. Figure 5–2 above depicts a weak source substation with two lines and some load. Assume that each substation has only one station DC supply that is not monitored for battery open. There is little doubt that the loss of a station DC supply for the large strong source substation in Figure 5–1 would have greater impact to the system than the loss of the station DC supply at the weak source substation in Figure 5–2. Worst case faults for these scenarios would result in a violation for the strong source example and could result in no violation for the weak source example. The strong source station requires a fix for the single charger or a single battery failure. A separate battery and charger could be installed at the strong source substation or battery open and low voltage monitors could be installed and connected to SCADA so that operators can be notified of a loss of the stations battery.

Appendix A – DC FAILURE (Loss of Station DC Supply)

Owners should be aware that the complete loss of the station DC Supply will cause the loss of all local tripping, SCADA control and observability, and could cause long delayed tripping.

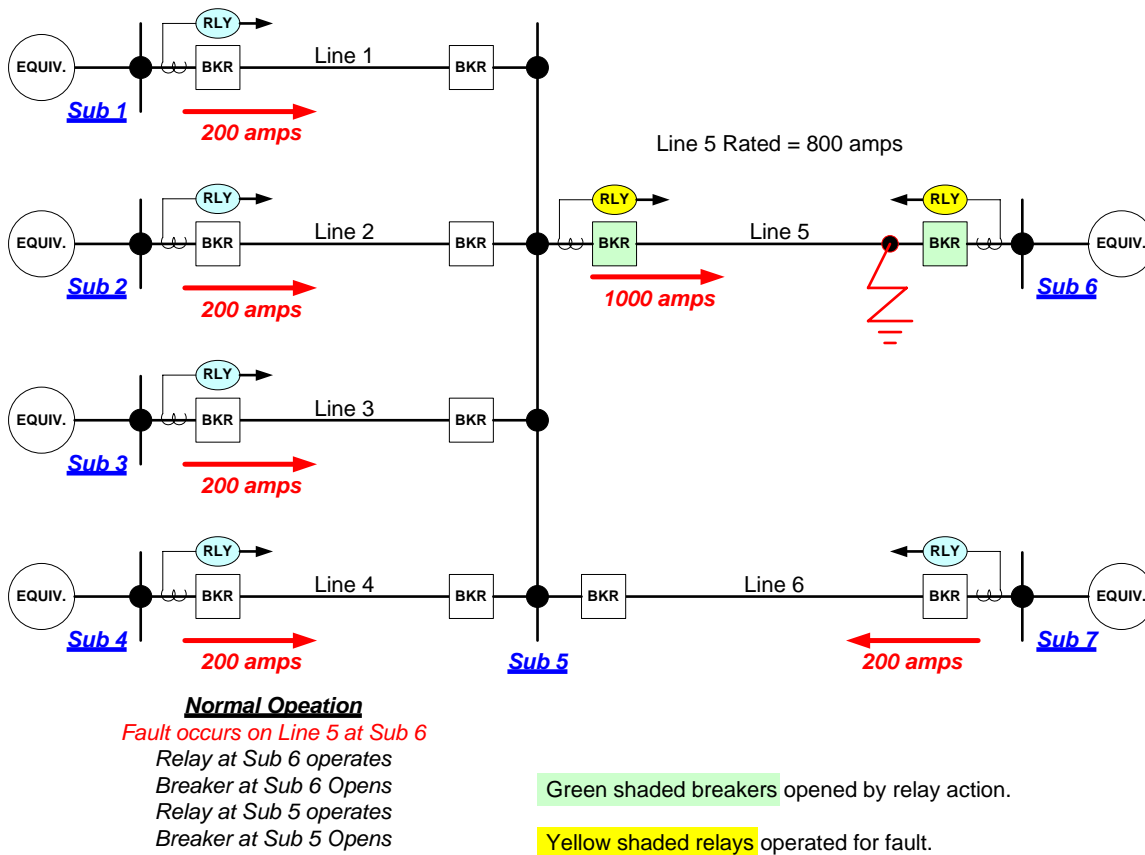
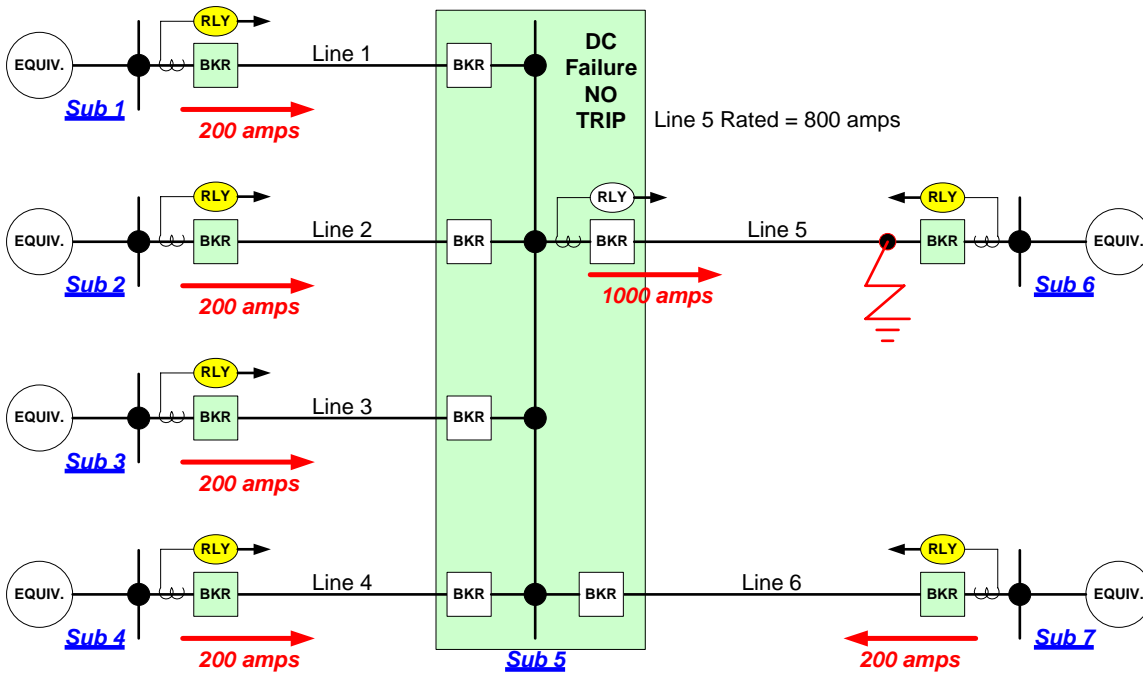

Figure A-1 — Normal Clearing

Consider the simple system in figure A-1. When all Protection Systems operate normally, a fault is cleared by the line relaying and breakers at both ends of the transmission line. However, consider that the station DC supply at Substation 5 (Sub 5) has failed and a fault occurs. There are two scenarios that can unfold. Figure A-2 depicts that all the remote line terminals have cleared to isolate the entire Sub 5. This assumes that the relaying at the remote ends of the transmission lines can sense this fault and if necessary sequentially operate one at a time to isolate this fault. This could take many seconds to isolate the fault. The worst case is that none of the remote relays senses the original fault and the line eventually sags and creates a fault closer to the substation until the remote relays sense the fault or an operator intervenes.

In those cases that the fault is not successfully cleared, there are several solutions that can be considered:

- Modify remote relay(s) settings to see fault but meet loadability (with load encroachment), and start sequential clearing sequence.
- Some relays could be replaced at the remote locations to accommodate sequential clearing.
- Modify the design at substation 5 to account for DC Battery failure:
 - Add a second DC supply to selective Protection Systems to provide isolation of fault or initiating sequential clearing.
 - Size the battery charger such that charger has the capability to supply enough energy to meet the required sequence of operations. This may include multiple trips and reclosings for line faults. Note: Care should be taken when using this option. The impact of depressed station service voltage as a result of the fault may limit the capability of the charger. Additionally, the worst case from a depressed voltage perspective will not be the far end fault which would make it necessary to identify the closest fault that would also go un-cleared.
 - Add redundant charger to account for DC battery charger failure. Note: Battery charger failure is an issue that must be addressed only if charger function is not remotely monitored and/ or the battery is not sized to accommodate the expected worst case response time.



LOSS of DC (operation)

Fault occurs on Line 5 at Sub 6

Relay at Sub 6 operates

Breaker at Sub 6 Opens

Fault current from Sub 5 is above rating of line

DC at Sub 5 is off and no tripping is available

Remote relaying must operate to protect line.

Green shaded breakers opened by relay action.

Yellow shaded relays operated for fault.

Figure A-2 — Complete Loss of DC with Remote Clearing

Appendix B – Excerpts from the 1997 NERC Transmission Planning Standards System Performance Requirements

Section III. System Protection and Control

A. Transmission Protection Systems

STANDARD

S2. Transmission Protection Systems shall provide redundancy such that no single Protection System component failure would prevent the interconnected transmission systems from meeting the system performance requirements of the I.A. Standards on Transmission Systems and associated Table I.

Measurement

M2. Where redundancy in the Protection Systems due to single Protection System component failures is necessary to meet the system performance requirements of the I.A. Standards on Transmission Systems and associated Table I, the transmission or Protection System owners shall provide, as a minimum, separate ac current inputs and separately fused dc control voltage with new or upgraded Protection System installations. Breaker failure protections need not be duplicated.

Each Region shall also develop a plan for reviewing the need for redundancy in its existing transmission Protection Systems and for implementing any required redundancy. Documentation of the Protection System redundancy reviews shall be provided to NERC, the Regions, and those entities responsible for the reliability of the interconnected transmission systems on request.

Full (100 percent) Compliance Requirements

A. Where assessments (Standard III.A. S1, M1) show the need for transmission Protection System redundancy due to single Protection System component failures, the transmission or Protection System owner shall provide the required component redundancy to meet the system performance requirements of Standard I.A. and associated Table I. These redundancy requirements should include:

- 1) Separate ac current inputs**
- 2) Separately fused dc control voltage**
- 3) Other redundant components**

Documentation of the planned implementation of the redundancy requirements should be provided to NERC, the Regions, and those entities responsible for the reliability of the interconnected transmission systems on request (within 30 days).

- B. Each Region shall have a plan for reviewing the transmission or Protection System owner’s assessments and for implementing the required component redundancy to promote consistency among its members. The Regional plan along with documentation of the redundancy reviews should be provided to NERC on request (within 30 days).

NERC 1997 Planning Standards Table 1

Category	Contingencies Initiating Event(s) and Contingency Component(s)	Components Out of Service	System Limits or Impacts				
			Thermal Limits	Voltage Limits	System Stable	Loss of Demand or Curtailed Firm Transfers	Cascading ^c Outages
A – No Contingencies	All Facilities in Service	None	Normal	Normal	Yes	No	No
B – Event resulting in the loss of a single component.	Single Line Ground (SLG) or 3-Phase (3Ø) Fault, with Normal Clearing: 1. Generator 2. Transmission Circuit 3. Transformer Loss of a Component without a Fault.	Single Single Single Single	Applicable Rating ^a (A/R) A/R A/R A/R	Applicable Rating ^a (A/R) A/R A/R A/R	Yes Yes Yes Yes	No ^b No ^b No ^b No ^b	No No No No
	Single Pole Block, Normal Clearing: 4. Single Pole (dc) Line	Single	A/R	A/R	Yes	No ^b	No
C – Event(s) resulting in the loss of two or more (multiple) components.	SLG Fault, with Normal Clearing: 1. Bus Section 2. Breaker (failure or internal fault)	Multiple Multiple	A/R A/R	A/R A/R	Yes Yes	Planned ^d Planned ^d	No No
	SLG or 3Ø Fault, with Normal Clearing, Manual System Adjustments, followed by another SLG or 3Ø Fault, with Normal Clearing: 3. Category B (B1, B2, B3, or B4) contingency, manual system adjustments, followed by another Category B (B1, B2, B3, or B4) contingency	Multiple	A/R	A/R	Yes	Planned ^d	No
	Bipolar Block, with Normal Clearing: 4. Bipolar (dc) Line Fault (non 3Ø), with Normal Clearing: 5. Double Circuit Towerline	Multiple Multiple	A/R A/R	A/R A/R	Yes Yes	Planned ^d Planned ^d	No No
	SLG Fault, with Delayed Clearing: 6. Generator 7. Transmission Circuit 8. Transformer 9. Bus Section	Multiple Multiple	A/R A/R	A/R A/R	Yes Yes	Planned ^d Planned ^d	No No

D ^e – Extreme event resulting in two or more (multiple) components removed or cascading out of service	<p>3Ø Fault, with Delayed Clearing (stuck breaker or protection system failure): 1. Generator 2. Transmission Circuit 3. Transformer 4. Bus Section</p> <p>3Ø Fault, with Normal Clearing: 5. Breaker (failure or internal fault)</p> <p>Other: 6. Loss of towerline with three or more circuits 7. All transmission lines on a common right-of way 8. Loss of a substation (one voltage level plus transformers) 9. Loss of a switching station (one voltage level plus transformers) 10. Loss of a all generating units at a station 11. Loss of a large load or major load center 12. Failure of a fully redundant special protection system (or remedial action scheme) to operate when required 13. Operation, partial operation, or misoperation of a fully redundant special protection system (or remedial action scheme) for an event or condition for which it was not intended to operate 14. Impact of severe power swings or oscillations from disturbances in another Regional Council.</p>	<p>Evaluate for risks and consequences.</p> <ul style="list-style-type: none"> May involve substantial loss of customer demand and generation in a widespread area or areas. Portions or all of the interconnected systems may or may not achieve a new, stable operating point. Evaluation of these events may require joint studies with neighboring systems. Document measures or procedures to mitigate the extent and effects of such events. Mitigation or elimination of the risks and consequences of these events shall be at the discretion of the entities responsible for the reliability of the interconnected transmission systems.
---	---	--

Footnotes to Table I.

- a) Applicable rating (A/R) refers to the applicable normal and emergency facility thermal rating or system voltage limit as determined and consistently applied by the system or facility owner.
- b) Planned or controlled interruption of generators or electric supply to radial customers or some local network customers, connected to or supplied by the faulted component or by the affected area, may occur in certain areas without impacting the overall security of the interconnected transmission systems. To prepare for the next contingency, system adjustments are permitted, including curtailments of contracted firm (non-recallable reserved) electric power transfers.
- c) Cascading is the uncontrolled successive loss of system elements triggered by an incident at any location. Cascading results in widespread service interruption which cannot be restrained from sequentially spreading beyond an area predetermined by appropriate studies.
- d) Depending on system design and expected system impacts, the controlled interruption of electric supply to customers (load shedding), the planned removal from service of certain generators, or the curtailment of contracted firm (non-recallable reserved) electric power transfers may be necessary to maintain the overall security of the interconnected transmission systems.
- e) A number of extreme contingencies that are listed under Category D and judged to be critical by the transmission planning entity(ies) will be selected for evaluation. It is not expected that all possible facility outages under each listed contingency of Category D will be evaluated.

NERC 2005 TPL Standards (Table I from TPL-001 – TPL-004)

Category	Contingencies	System Limits or Impacts		
	Initiating Event(s) and Contingency Element(s)	System Stable and both Thermal and Voltage Limits within Applicable Rating ^a	Loss of Demand or Curtailed Firm Transfers	Cascading Outages
A No Contingencies	All Facilities in Service	Yes	No	No
B Event resulting in the loss of a single element.	Single Line Ground (SLG) or 3-Phase (3Ø) Fault, with Normal Clearing: 1. Generator 2. Transmission Circuit 3. Transformer Loss of an Element without a Fault	Yes Yes Yes Yes	No ^b No ^b No ^b No ^b	No No No No
	Single Pole Block, Normal Clearing ^e : 4. Single Pole (dc) Line	Yes	No ^b	No
C Event(s) resulting in the loss of two or more (multiple) elements.	SLG Fault, with Normal Clearing ^e : 1. Bus Section	Yes	Planned/ Controlled ^d	No
	2. Breaker (failure or internal Fault)	Yes	Planned/ Controlled ^d	No
	SLG or 3Ø Fault, with Normal Clearing ^e , Manual System Adjustments, followed by another SLG or 3Ø Fault, with Normal Clearing ^e : 3. Category B (B1, B2, B3, or B4) contingency, manual system adjustments, followed by another Category B (B1, B2, B3, or B4) contingency	Yes	Planned/ Controlled ^d	No
	Bipolar Block, with Normal Clearing ^e : 4. Bipolar (dc) Line Fault (non 3Ø), with Normal Clearing ^e :	Yes	Planned/ Controlled ^d	No
	5. Any two circuits of a multiple circuit towerline ^f	Yes	Planned/ Controlled ^d	No
SLG Fault, with Delayed Clearing ^e (stuck breaker or protection system failure):	6. Generator	Yes	Planned/ Controlled ^d	No
	7. Transformer	Yes	Planned/ Controlled ^d	No
	8. Transmission Circuit	Yes	Planned/ Controlled ^d	No
	9. Bus Section	Yes	Planned/ Controlled ^d	No

<p>D^d</p> <p>Extreme event resulting in two or more (multiple) elements removed or Cascading out of service.</p>	<p>3Ø Fault, with Delayed Clearing^e (stuck breaker or protection system failure):</p> <table border="0"> <tr> <td>1. Generator</td> <td>3. Transformer</td> </tr> <tr> <td>2. Transmission Circuit</td> <td>4. Bus Section</td> </tr> </table> <hr/> <p>3Ø Fault, with Normal Clearing^e:</p> <hr/> <p>5. Breaker (failure or internal Fault)</p> <hr/> <p>6. Loss of towerline with three or more circuits</p> <p>7. All transmission lines on a common right-of way</p> <p>8. Loss of a substation (one voltage level plus transformers)</p> <p>9. Loss of a switching station (one voltage level plus transformers)</p> <p>10. Loss of all generating units at a station</p> <p>11. Loss of a large Load or major Load center</p> <p>12. Failure of a fully redundant Special Protection System (or remedial action scheme) to operate when required</p> <p>13. Operation, partial operation, or misoperation of a fully redundant Special Protection System (or Remedial Action Scheme) in response to an event or abnormal system condition for which it was not intended to operate</p> <p>14. Impact of severe power swings or oscillations from Disturbances in another Regional Reliability Organization.</p>	1. Generator	3. Transformer	2. Transmission Circuit	4. Bus Section	<p>Evaluate for risks and consequences.</p> <ul style="list-style-type: none"> ▪ May involve substantial loss of customer Demand and generation in a widespread area or areas. ▪ Portions or all of the interconnected systems may or may not achieve a new, stable operating point. ▪ Evaluation of these events may require joint studies with neighboring systems.
1. Generator	3. Transformer					
2. Transmission Circuit	4. Bus Section					

- a) Applicable rating refers to the applicable Normal and Emergency facility thermal Rating or system voltage limit as determined and consistently applied by the system or facility owner. Applicable Ratings may include Emergency Ratings applicable for short durations as required to permit operating steps necessary to maintain system control. All Ratings must be established consistent with applicable NERC Reliability Standards addressing Facility Ratings.
- b) Planned or controlled interruption of electric supply to radial customers or some local Network customers, connected to or supplied by the Faulted element or by the affected area, may occur in certain areas without impacting the overall reliability of the interconnected transmission systems. To prepare for the next contingency, system adjustments are permitted, including curtailments of contracted Firm (non-recallable reserved) electric power Transfers.
- c) Depending on system design and expected system impacts, the controlled interruption of electric supply to customers (load shedding), the planned removal from service of certain generators, and/or the curtailment of contracted Firm (non-recallable reserved) electric power Transfers may be necessary to maintain the overall reliability of the interconnected transmission systems.
- d) A number of extreme contingencies that are listed under Category D and judged to be critical by the transmission planning entity(ies) will be selected for evaluation. It is not expected that all possible facility outages under each listed contingency of Category D will be evaluated.
- e) Normal clearing is when the protection system operates as designed and the Fault is cleared in the time normally expected with proper functioning of the installed protection systems. Delayed clearing of a Fault is due to failure of any protection system component such as a relay, circuit breaker, or current transformer, and not because of an intentional design delay.
- f) System assessments may exclude these events where multiple circuit towers are used over short distances (e.g., station entrance, river crossings) in accordance with Regional exemption criteria.

Appendix C – System Protection and Control Subcommittee

John L. Ciuffo

Chairman

Manager, P&C Strategies and Standards
Hydro One, Inc.

Jonathan Sykes

Vice-Chairman

Senior Principal Engineer, System Protection
Salt River Project

Michael J. McDonald

Investor-Owned Utility

Senior Principal Engineer, System Protection
Ameren Services Company

William J. Miller

Investor-Owned Utility

Consulting Engineer
Exelon Corporation

James D. Roberts

U.S. Federal

Transmission Planning
Tennessee Valley Authority

Sungsoo Kim

Canada Provincial

Senior Protection Engineer
Ontario Power Generation Inc.

Joe T. Uchiyama

U.S. Federal

Senior Electrical Engineer
U.S. Bureau of Reclamation

Charles W. Rogers

Transmission Dependent Utility

Principal Engineer
Consumers Energy Co.

Joseph M. Burdis

ISO/RTO

Senior Consultant / Engineer, Transmission
and Interconnection Planning
PJM Interconnection, L.L.C.

Jim Ingleson

ISO/RTO

Senior Electric System Planning Engineer
New York Independent System Operator

Bryan J. Gwyn

RE – NPCC

Manager, Protection Standards and Support
National Grid USA

Philip Tatro

RE – NPCC Alternate

Consulting Engineer
National Grid USA

Henry (Hank) Miller

RE – RFC

Principal Electrical Engineer
American Electric Power

Deven Bhan

RE – MRO

Electrical Engineer, System Protection
Western Area Power Administration

John Mulhausen

RE – FRCC

Manager, Design and Standards
Florida Power & Light Co.

Philip B. Winston

RE – SERC

Manager, Protection and Control
Georgia Power Company

Dean Sikes

RE – SPP

Manager - Transmission Protection, Apparatus, & Metering
Cleco Power

Samuel Francis

RE – TRE

Senior Director of Engineering
Oncor Electric Delivery

Baj Agrawal

RE – WECC

Principal Engineer
Arizona Public Service Company

W. O. (Bill) Kennedy

Canada Member-at-Large

Principal
b7kennedy & Associates Inc.

Robert W. Cummings

NERC Staff Coordinator

Director of Event Analysis & Information Exchange
NERC

Tom Wiedman

Subject Matter Expert – NERC Consultant

President
Wiedman Power System Consulting, Ltd.

Jonathan D Gardell

Subject Matter Expert – NERC Consultant

Executive Advisor
Quanta Technology

Eric A Udren

Subject Matter Expert

Executive Advisor
Quanta Technology

Murty Yalla
Subject Matter Expert
President
Beckwith Electric Company Inc.

David Angell
Correspondent
T&D Planning Engineering Leader
Idaho Power Company

Hasnain Ashrafi
Correspondent
Engineer
Sargent & Lundy

Dac-Phuoc Bui
Correspondent
Engineer
Hydro-Quebec TransÉnergie

Jeanne Harshbarger
Correspondent
System Protection Engineer
Puget Sound Energy, Inc.

Fred Ipock
Correspondent
Senior Engineer - Substations & Protection
City Utilities of Springfield, Missouri

Evan T. Sage
Correspondent
Senior Engineer
Potomac Electric Power Company

Joe Spencer
Correspondent
Manager of Planning and Engineering
SERC Reliability Corporation

Bob Stuart
Correspondent
Senior Director - Transmission
BrightSource Energy, Inc.